



**THE DATASHEET OF
UC5603N**



- Complies with SCSI, SCSI-2 and SPI-2 Standards
- 6-pF Channel Capacitance during Disconnect
- 100- μ A Supply Current in Disconnect Mode
- Meets SCSI Hot Plugging
- -400-mA Sourcing Current for Termination
- +400-mA Sinking Current for Active Negation Drivers
- Logic Command Disconnects all Termination Lines
- Trimmed Termination Current to 3%
- Trimmed Impedance to 3%
- Negative Clamping on all Signal Lines
- Current Limit and Thermal Shutdown Protection

description

The UC5603 provides 9 lines of active termination for a SCSI (Small Computers Systems Interface) parallel bus. The SCSI standard recommends active termination at both ends of the cable segment.

The UC5603 provides a disconnect feature which, when opened or driven high, will disconnect all terminating resistors, and disables the regulator; greatly reducing standby power. The output channels remain high impedance even without Tempwr applied. A low channel capacitance of 6 pF allows units at interim points of the bus to have little to no effect on the signal integrity.

Functionally the UC5603 is similar to its predecessor, the UC5601 – 18 line Active Terminator. Several electrical enhancements were incorporated in the UC5603, such as a sink/source regulator output stage to accommodate all signal lines at 5 V, while the regulator remains at its nominal value, reduced channel capacitance to 6 pF typical, and as with the UC5601, custom power packages are utilized to allow normal operation at full power conditions (1.2 watts).

functional block diagram

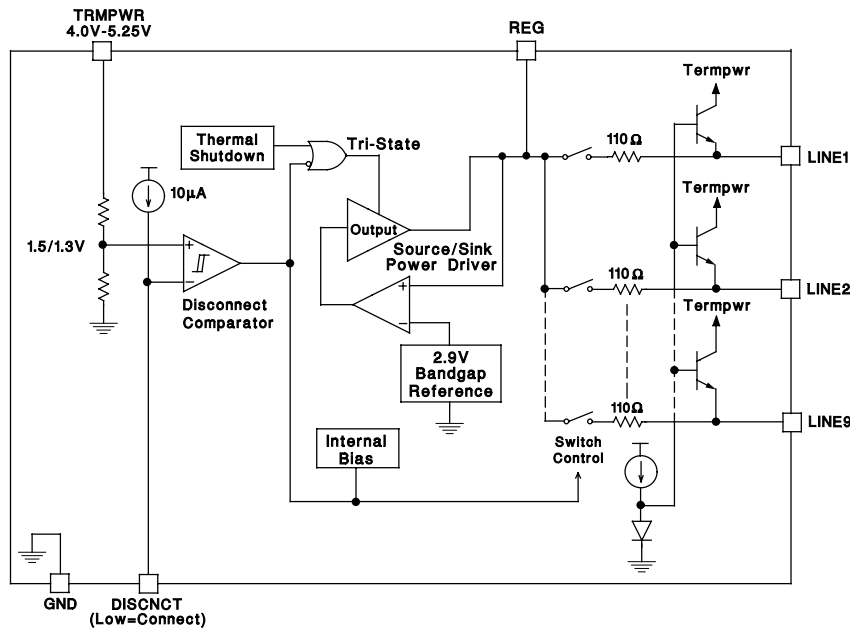

UDG-94049



Please be aware that an important notice concerning availability, standard warranty, and use in critical applications of Texas Instruments semiconductor products and disclaimers thereto appears at the end of this data sheet.

PRODUCTION DATA information is current as of publication date. Products conform to specifications per the terms of Texas Instruments standard warranty. Production processing does not necessarily include testing of all parameters.

UC5603

9-LINE SCSI ACTIVE TERMINATOR

SLUS195B – MARCH 1997 – REVISED NOVEMBER 2003

description (continued)

Internal circuit trimming is utilized, first to trim the impedance to a 3% tolerance, and then most importantly, to trim the output current to a 3% tolerance, as close to the max SCSI spec as possible, which maximizes noise margin in fast SCSI operation.

Other features include negative clamping on all signal lines to protect external circuitry from latch-up, thermal shutdown and current limit.

This device is offered in low thermal resistance versions of the industry standard 16 pin narrow body SOIC.

connection diagrams

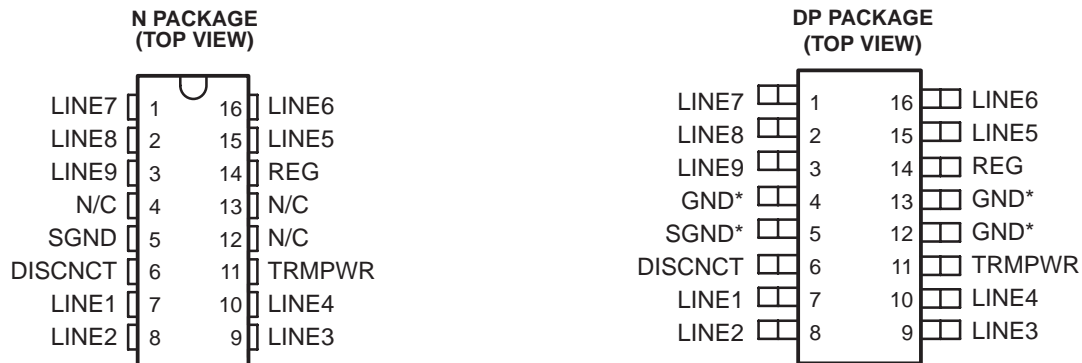

* DP package pin 5 serves as signal ground; pins 4, 12, 13 serve as heatsink/ground.

ORDERING INFORMATION

T _A = T _J	Packaged Devices	
	DIL -16(N)	SOIC-16 (DP)†
0°C to 70°C	UC5603N	UCUC5603DP

† DP (SOIC-16) packages are available taped and reeled. Add TR suffix to device type (e.g. UC5603DPTR) to order quantities of 2000 devices per reel.

absolute maximum ratings over operating free-air temperature (unless otherwise noted)^{†‡}

Tempwr voltage	7 V
Signal line voltage	0V to 7 V
Regulator output current	0.5 A
Storage temperature	–65°C to 150°C
Operating temperature	–55°C to 150°C
Lead temperature (soldering, 10 sec.)	300°C

[†] Stresses beyond those listed under “absolute maximum ratings” may cause permanent damage to the device. These are stress ratings only, and functional operation of the device at these or any other conditions beyond those indicated under “recommended operating conditions” is not implied. Exposure to absolute-maximum-rated conditions for extended periods may affect device reliability.

[‡] Unless otherwise specified all voltages are with respect to Ground. Currents are positive into, negative out of the specified terminal. Consult Packaging Section of Unitrode Integrated Circuits databook for thermal limitations and considerations of packages.

recommended operating conditions

Tempwr voltage	3.8 V to 5.25 V
Signal line voltage	0 V to 5 V
Disconnect input voltage	0 V to Tempwr

electrical characteristics, these specifications apply for $T_A = 0^\circ\text{C}$ to 70°C . TRMPWR = 4.75 V DISCNCT = 0 V, $T_A = T_J$, (unless otherwise stated)

supply current section

PARAMETER	TEST CONDITIONS	MIN	TYP	MAX	UNITS
Tempwr supply current	All termination lines = Open		12	18	mA
	All termination lines = 0.5 V		200	220	mA
Power down mode	DISCNCT = Open		100	150	μA

output section (terminator lines)

PARAMETER	TEST CONDITIONS	MIN	TYP	MAX	UNITS		
Terminator impedance	$\Delta I_{\text{LINE}} = -5 \text{ mA to } -15 \text{ mA}$	107	110	113	Ω		
Output high voltage	$V_{\text{TRMPWR}} = 4 \text{ V}$, See Note 1	2.7	2.9		V		
Max output current	$V_{\text{LINE}} = 0.5 \text{ V}$	$T_J = 25^\circ\text{C}$	–21.1	–21.9	–22.4	mA	
		$0^\circ\text{C} < T_J < 70^\circ\text{C}$	–20.5	–21.9	–22.4	mA	
Max output current	$V_{\text{LINE}} = 0.5 \text{ V}$, See Note 1	TRMPWR = 4 V,	$T_J = 25^\circ\text{C}$	–20.3	–21.9	–22.4	mA
			$0^\circ\text{C} < T_J < 70^\circ\text{C}$	–19.8	–21.9	–22.4	mA
	$V_{\text{LINE}} = 0.2 \text{ V}$,	TRMPWR = 4.0 V to 5.25 V	$0^\circ\text{C} < T_J < 70^\circ\text{C}$	–22.0	–24.0	–25.4	mA
Output clamp level	$I_{\text{LINE}} = -30 \text{ mA}$	–0.2	–0.05	0.1	V		
Output leakage	DISCNCT = 4 V	TRMPWR = 0 V to 5.25, VREG = 0 V	$V_{\text{LINE}} = 0 \text{ to } 4 \text{ V}$	10	400	nA	
			$V_{\text{LINE}} = 5.25 \text{ V}$		100	μA	
		TRMPWR = 0 V to 5.25 V, $V_{\text{LINE}} = 0 \text{ V to } 5.25 \text{ V}$	REG = Open	10	400	nA	
Output capacitance	DISCNCT = Open	See Note 2	DP Package	6	8	pF	

NOTES: 1. Measuring each termination line while other 8 are low (0.5 V).
2. Ensured by design. Not production tested.

UC5603 9-LINE SCSI ACTIVE TERMINATOR

SLUS195B – MARCH 1997 – REVISED NOVEMBER 2003

regulator section

PARAMETER	TEST CONDITIONS	MIN	TYP	MAX	UNITS
Regulator output voltage		2.8	2.9	3	V
Regulator output voltage	All termination lines = 5 V	2.8	2.9	3	V
Line regulation	TRMPWR = 4 V to 6 V		10	20	mV
Load regulation	I _{REG} = 100 mA to -100 mA		20	50	mV
Drop out voltage	All termination lines = 0.5 V		0.7	1	V
Short circuit current	V _{REG} = 0 V	-200	-400	-600	mA
Sinking current capability	V _{REG} = 3.5 V	200	400	600	mA
Thermal shutdown			170		°C
Thermal shutdown hysteresis			10		°C

disconnect section

PARAMETER	TEST CONDITIONS	MIN	TYP	MAX	UNITS
Disconnect threshold		1.3	1.5	1.7	V
Threshold hysteresis		100	160	250	mV
Input current	DISCNCT = 0 V		10	15	mA

APPLICATION INFORMATION

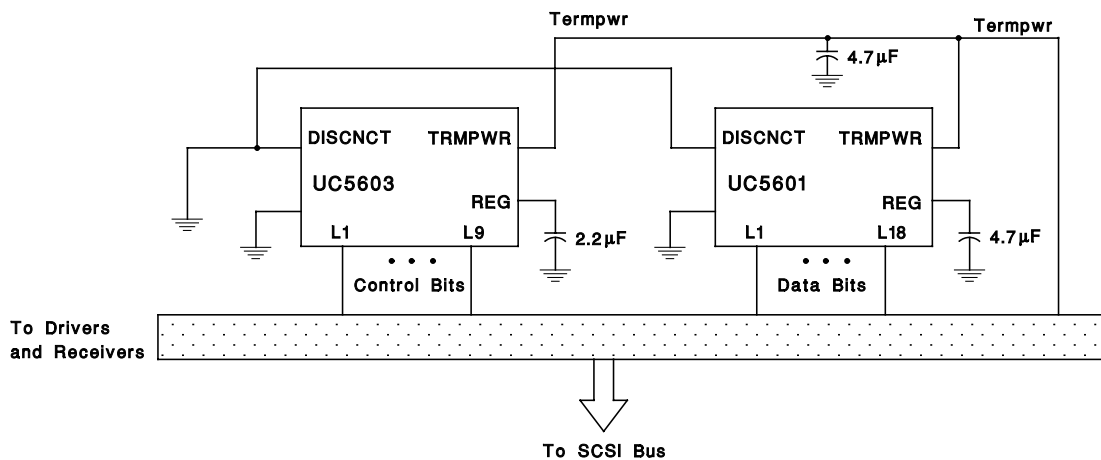

UDG-94050

Figure 1. Typical Wide SCSI Bus Configurations Utilizing 1 UC5601 and 1 UC5603 Device

APPLICATION INFORMATION

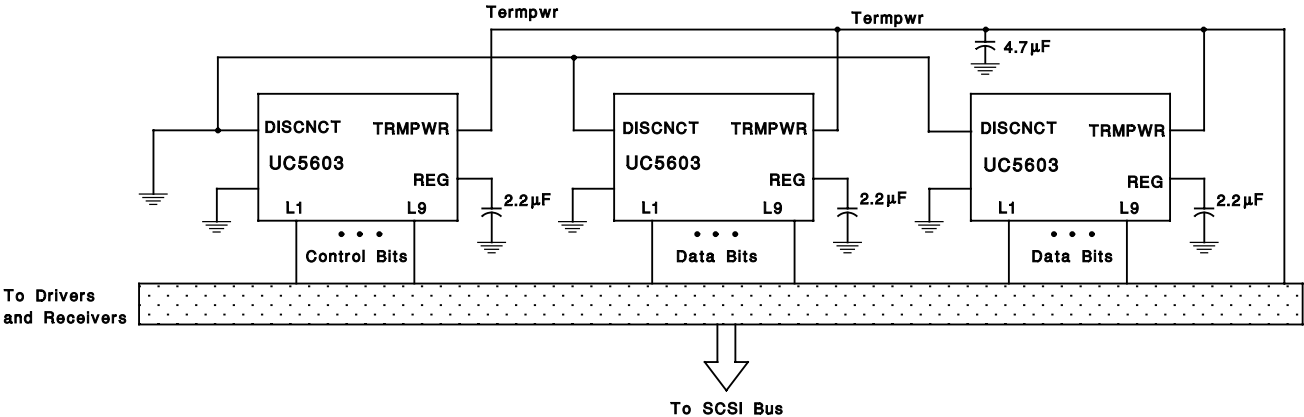

UDG-94051

Figure 2. Typical Wide SCSI Bus Configurations Utilizing 3 UC5603 Devices

PACKAGING INFORMATION

Orderable Device	Status ⁽¹⁾	Package Type	Package Drawing	Pins	Package Qty	Eco Plan ⁽²⁾	Lead/Ball Finish	MSL Peak Temp ⁽³⁾
UC5603DP	ACTIVE	SOIC	D	16	40	Green (RoHS & no Sb/Br)	CU NIPDAU	Level-2-260C-1 YEAR
UC5603DPG4	ACTIVE	SOIC	D	16	40	Green (RoHS & no Sb/Br)	CU NIPDAU	Level-2-260C-1 YEAR
UC5603DPR	NRND	SOIC	D	16		TBD	Call TI	Call TI
UC5603DPRTR	NRND	SOIC	D	16		TBD	Call TI	Call TI
UC5603DPTR	ACTIVE	SOIC	D	16	2500	Green (RoHS & no Sb/Br)	CU NIPDAU	Level-2-260C-1 YEAR
UC5603DPTRG4	ACTIVE	SOIC	D	16	2500	Green (RoHS & no Sb/Br)	CU NIPDAU	Level-2-260C-1 YEAR
UC5603J	OBSOLETE	CDIP	J	16		TBD	Call TI	Call TI
UC5603N	ACTIVE	PDIP	N	16	25	Green (RoHS & no Sb/Br)	CU NIPDAU	N / A for Pkg Type
UC5603NG4	ACTIVE	PDIP	N	16	25	Green (RoHS & no Sb/Br)	CU NIPDAU	N / A for Pkg Type
UC5603QPTR	NRND	PLCC	FN	28	750	Green (RoHS & no Sb/Br)	CU NIPDAU	Level-3-260C-168 HR

⁽¹⁾ The marketing status values are defined as follows:

ACTIVE: Product device recommended for new designs.

LIFEBUY: TI has announced that the device will be discontinued, and a lifetime-buy period is in effect.

NRND: Not recommended for new designs. Device is in production to support existing customers, but TI does not recommend using this part in a new design.

PREVIEW: Device has been announced but is not in production. Samples may or may not be available.

OBSOLETE: TI has discontinued the production of the device.

⁽²⁾ Eco Plan - The planned eco-friendly classification: Pb-Free (RoHS), Pb-Free (RoHS Exempt), or Green (RoHS & no Sb/Br) - please check <http://www.ti.com/productcontent> for the latest availability information and additional product content details.

TBD: The Pb-Free/Green conversion plan has not been defined.

Pb-Free (RoHS): TI's terms "Lead-Free" or "Pb-Free" mean semiconductor products that are compatible with the current RoHS requirements for all 6 substances, including the requirement that lead not exceed 0.1% by weight in homogeneous materials. Where designed to be soldered at high temperatures, TI Pb-Free products are suitable for use in specified lead-free processes.

Pb-Free (RoHS Exempt): This component has a RoHS exemption for either 1) lead-based flip-chip solder bumps used between the die and package, or 2) lead-based die adhesive used between the die and leadframe. The component is otherwise considered Pb-Free (RoHS compatible) as defined above.

Green (RoHS & no Sb/Br): TI defines "Green" to mean Pb-Free (RoHS compatible), and free of Bromine (Br) and Antimony (Sb) based flame retardants (Br or Sb do not exceed 0.1% by weight in homogeneous material)

⁽³⁾ MSL, Peak Temp. -- The Moisture Sensitivity Level rating according to the JEDEC industry standard classifications, and peak solder temperature.

Important Information and Disclaimer:The information provided on this page represents TI's knowledge and belief as of the date that it is provided. TI bases its knowledge and belief on information provided by third parties, and makes no representation or warranty as to the accuracy of such information. Efforts are underway to better integrate information from third parties. TI has taken and continues to take reasonable steps to provide representative and accurate information but may not have conducted destructive testing or chemical analysis on incoming materials and chemicals. TI and TI suppliers consider certain information to be proprietary, and thus CAS numbers and other limited information may not be available for release.

In no event shall TI's liability arising out of such information exceed the total purchase price of the TI part(s) at issue in this document sold by TI to Customer on an annual basis.

TAPE AND REEL INFORMATION



QUADRANT ASSIGNMENTS FOR PIN 1 ORIENTATION IN TAPE



*All dimensions are nominal

Device	Package Type	Package Drawing	Pins	SPQ	Reel Diameter (mm)	Reel Width W1 (mm)	A0 (mm)	B0 (mm)	K0 (mm)	P1 (mm)	W (mm)	Pin1 Quadrant
UC5603DPTR	SOIC	D	16	2500	330.0	16.4	6.5	10.3	2.1	8.0	16.0	Q1

TAPE AND REEL BOX DIMENSIONS



*All dimensions are nominal

Device	Package Type	Package Drawing	Pins	SPQ	Length (mm)	Width (mm)	Height (mm)
UC5603DPTR	SOIC	D	16	2500	346.0	346.0	33.0

J (R-GDIP-T**)

14 LEADS SHOWN

CERAMIC DUAL IN-LINE PACKAGE



DIM \ PINS **	14	16	18	20
A	0.300 (7,62) BSC	0.300 (7,62) BSC	0.300 (7,62) BSC	0.300 (7,62) BSC
B MAX	0.785 (19,94)	.840 (21,34)	0.960 (24,38)	1.060 (26,92)
B MIN	—	—	—	—
C MAX	0.300 (7,62)	0.300 (7,62)	0.310 (7,87)	0.300 (7,62)
C MIN	0.245 (6,22)	0.245 (6,22)	0.220 (5,59)	0.245 (6,22)



4040083/F 03/03

- NOTES:
- All linear dimensions are in inches (millimeters).
 - This drawing is subject to change without notice.
 - This package is hermetically sealed with a ceramic lid using glass frit.
 - Index point is provided on cap for terminal identification only on press ceramic glass frit seal only.
 - Falls within MIL STD 1835 GDIP1-T14, GDIP1-T16, GDIP1-T18 and GDIP1-T20.

D (R-PDSO-G16)

PLASTIC SMALL-OUTLINE PACKAGE

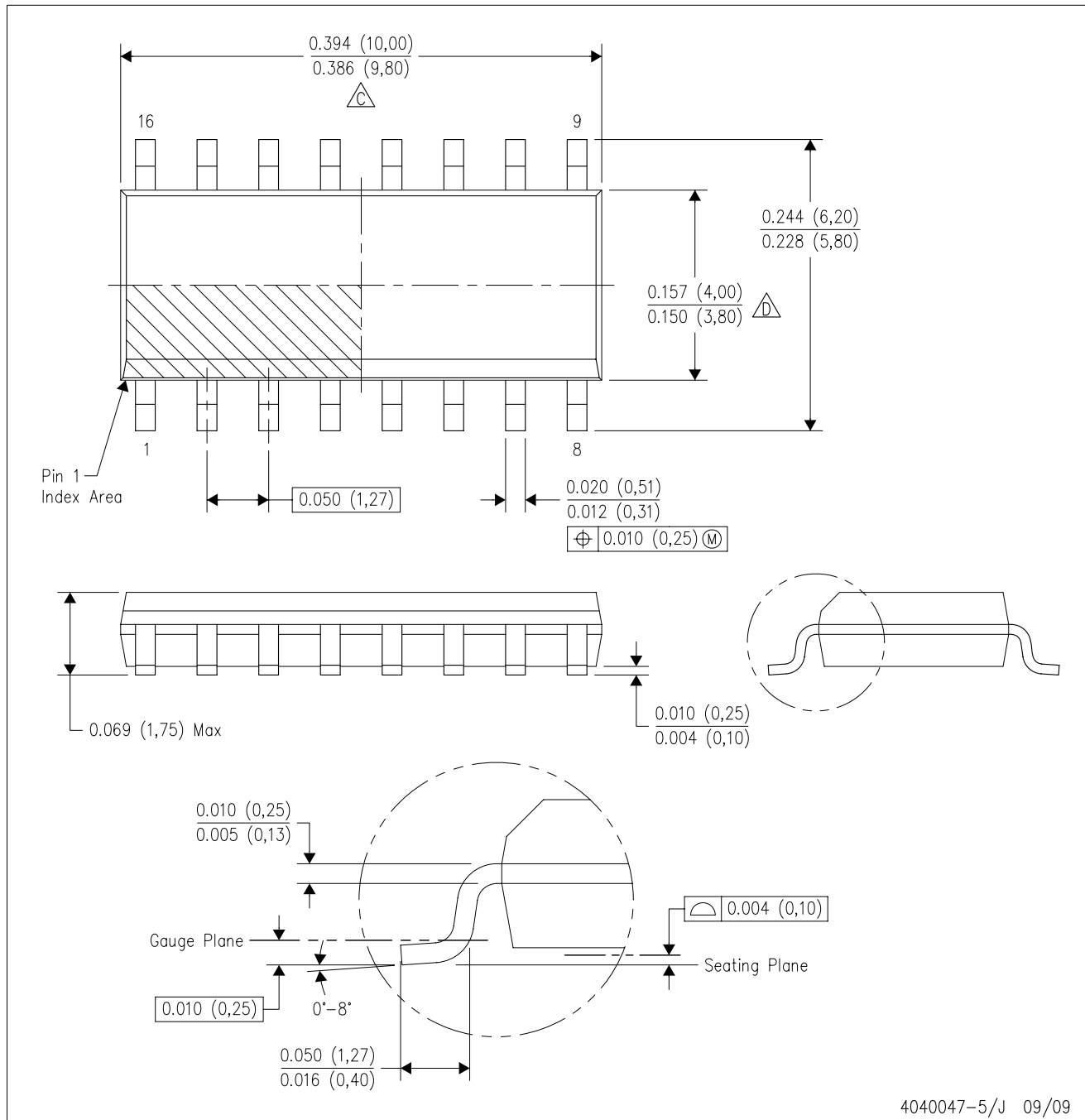

- NOTES:
- A. All linear dimensions are in inches (millimeters).
 - B. This drawing is subject to change without notice.
 - C. Body length does not include mold flash, protrusions, or gate burrs. Mold flash, protrusions, or gate burrs shall not exceed .006 (0,15) per end.
 - D. Body width does not include interlead flash. Interlead flash shall not exceed .017 (0,43) per side.
 - E. Reference JEDEC MS-012 variation AC.

D(R-PDSO-G16)

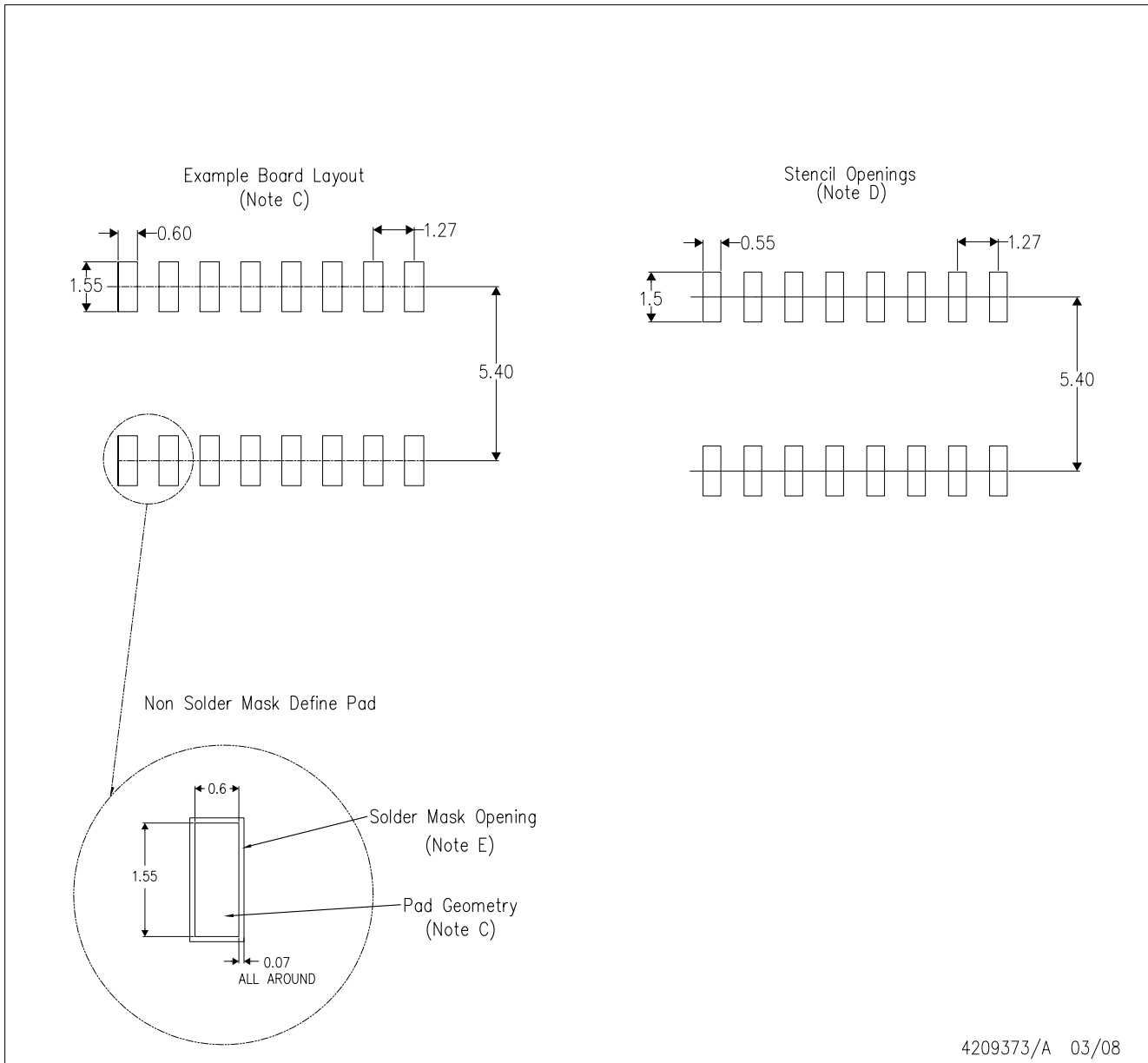

- NOTES:
- A. All linear dimensions are in millimeters.
 - B. This drawing is subject to change without notice.
 - C. Refer to IPC7351 for alternate board design.
 - D. Laser cutting apertures with trapezoidal walls and also rounding corners will offer better paste release. Customers should contact their board assembly site for stencil design recommendations. Refer to IPC-7525
 - E. Customers should contact their board fabrication site for solder mask tolerances between and around signal pads.

FN (S-PQCC-J**)

PLASTIC J-LEADED CHIP CARRIER

20 PIN SHOWN

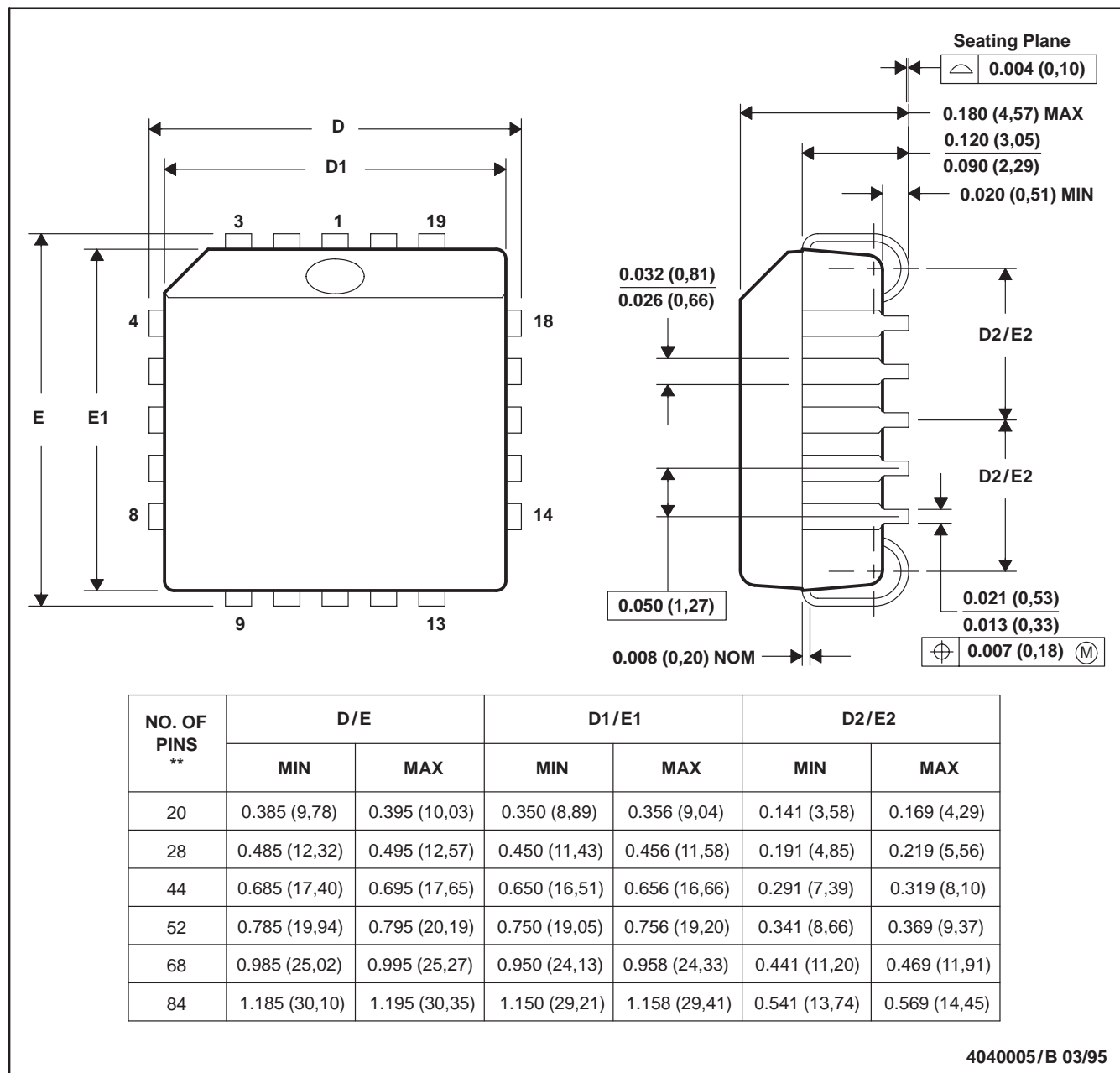

- NOTES: A. All linear dimensions are in inches (millimeters).
 B. This drawing is subject to change without notice.
 C. Falls within JEDEC MS-018

N (R-PDIP-T**)

PLASTIC DUAL-IN-LINE PACKAGE

16 PINS SHOWN



- NOTES:
- A. All linear dimensions are in inches (millimeters).
 - B. This drawing is subject to change without notice.
 - (C) Falls within JEDEC MS-001, except 18 and 20 pin minimum body length (Dim A).
 - (D) The 20 pin end lead shoulder width is a vendor option, either half or full width.

IMPORTANT NOTICE

Texas Instruments Incorporated and its subsidiaries (TI) reserve the right to make corrections, modifications, enhancements, improvements, and other changes to its products and services at any time and to discontinue any product or service without notice. Customers should obtain the latest relevant information before placing orders and should verify that such information is current and complete. All products are sold subject to TI's terms and conditions of sale supplied at the time of order acknowledgment.

TI warrants performance of its hardware products to the specifications applicable at the time of sale in accordance with TI's standard warranty. Testing and other quality control techniques are used to the extent TI deems necessary to support this warranty. Except where mandated by government requirements, testing of all parameters of each product is not necessarily performed.

TI assumes no liability for applications assistance or customer product design. Customers are responsible for their products and applications using TI components. To minimize the risks associated with customer products and applications, customers should provide adequate design and operating safeguards.

TI does not warrant or represent that any license, either express or implied, is granted under any TI patent right, copyright, mask work right, or other TI intellectual property right relating to any combination, machine, or process in which TI products or services are used. Information published by TI regarding third-party products or services does not constitute a license from TI to use such products or services or a warranty or endorsement thereof. Use of such information may require a license from a third party under the patents or other intellectual property of the third party, or a license from TI under the patents or other intellectual property of TI.

Reproduction of TI information in TI data books or data sheets is permissible only if reproduction is without alteration and is accompanied by all associated warranties, conditions, limitations, and notices. Reproduction of this information with alteration is an unfair and deceptive business practice. TI is not responsible or liable for such altered documentation. Information of third parties may be subject to additional restrictions.

Resale of TI products or services with statements different from or beyond the parameters stated by TI for that product or service voids all express and any implied warranties for the associated TI product or service and is an unfair and deceptive business practice. TI is not responsible or liable for any such statements.

TI products are not authorized for use in safety-critical applications (such as life support) where a failure of the TI product would reasonably be expected to cause severe personal injury or death, unless officers of the parties have executed an agreement specifically governing such use. Buyers represent that they have all necessary expertise in the safety and regulatory ramifications of their applications, and acknowledge and agree that they are solely responsible for all legal, regulatory and safety-related requirements concerning their products and any use of TI products in such safety-critical applications, notwithstanding any applications-related information or support that may be provided by TI. Further, Buyers must fully indemnify TI and its representatives against any damages arising out of the use of TI products in such safety-critical applications.

TI products are neither designed nor intended for use in military/aerospace applications or environments unless the TI products are specifically designated by TI as military-grade or "enhanced plastic." Only products designated by TI as military-grade meet military specifications. Buyers acknowledge and agree that any such use of TI products which TI has not designated as military-grade is solely at the Buyer's risk, and that they are solely responsible for compliance with all legal and regulatory requirements in connection with such use.

TI products are neither designed nor intended for use in automotive applications or environments unless the specific TI products are designated by TI as compliant with ISO/TS 16949 requirements. Buyers acknowledge and agree that, if they use any non-designated products in automotive applications, TI will not be responsible for any failure to meet such requirements.

Following are URLs where you can obtain information on other Texas Instruments products and application solutions:

Products

Amplifiers	amplifier.ti.com
Data Converters	dataconverter.ti.com
DLP® Products	www.dlp.com
DSP	dsp.ti.com
Clocks and Timers	www.ti.com/clocks
Interface	interface.ti.com
Logic	logic.ti.com
Power Mgmt	power.ti.com
Microcontrollers	microcontroller.ti.com
RFID	www.ti-rfid.com
RF/IF and ZigBee® Solutions	www.ti.com/lprf

Applications

Audio	www.ti.com/audio
Automotive	www.ti.com/automotive
Broadband	www.ti.com/broadband
Digital Control	www.ti.com/digitalcontrol
Medical	www.ti.com/medical
Military	www.ti.com/military
Optical Networking	www.ti.com/opticalnetwork
Security	www.ti.com/security
Telephony	www.ti.com/telephony
Video & Imaging	www.ti.com/video
Wireless	www.ti.com/wireless

Mailing Address: Texas Instruments, Post Office Box 655303, Dallas, Texas 75265
Copyright © 2009, Texas Instruments Incorporated

Looking for pricing, stock, or lifecycle information?

Click below to explore more details on WIN SOURCE:

 [View UC5603N on WIN SOURCE](#)

 [Texas Instruments](#) Information

Optimize Your Supply Chain with WIN SOURCE Solutions

-  Global Sourcing Solution
-  Obsolete Management
-  Cost Control Management
-  Shortage Management
-  Alternative Solution
-  Excess Inventory Management