



**THE DATASHEET OF
TRS232EIPWG4**



TRS232E Dual RS-232 Driver and Receiver with IEC61000-4-2 Protection

1 Features

- Meets or exceeds TIA/RS-232-F and ITU recommendation V.28
- Operates from a single 5V supply with 1µF charge-pump capacitors
- Operates up to 250kbit/s
- Two drivers and two receivers
- ±30V Input levels
- Low supply current: 8mA typical
- ESD protection for RS-232 bus pins
 - ±15-kV Human-body model (HBM)
 - ±8-kV IEC61000-4-2, Contact discharge
 - ±15-kV IEC61000-4-2, Air-gap discharge

2 Applications

- TIA/RS-232-F
- [Battery-powered systems](#)
- Terminals
- Modems
- Computers

3 Description

The TRS232E is a dual driver/receiver that includes a capacitive voltage generator to supply TIA/RS-232-F voltage levels from a single 5-V supply. Each receiver converts TIA/RS-232-F inputs to 5V TTL/CMOS levels. This receiver has a typical threshold of 1.3V, a typical hysteresis of 0.5V, and can accept ±30V inputs. Each driver converts TTL/CMOS input levels into TIA/RS-232-F levels. The driver, receiver, and voltage-generator functions are available as cells in the Texas Instruments LinASIC™ library.

Package Information

PART NUMBER	PACKAGE ⁽¹⁾	PACKAGE SIZE ⁽²⁾
TRS232E	SOIC (D, 16)	9.9mm x 6mm
	SOIC (DW, 16)	10.4mm x 10.3mm
	PDIP (N, 16)	19.3mm x 9.4mm
	TSSOP (PW, 16)	5mm x 6.4mm

(1) For more information, see [Section 11](#).

(2) The package size (length × width) is a nominal value and includes pins, where applicable.

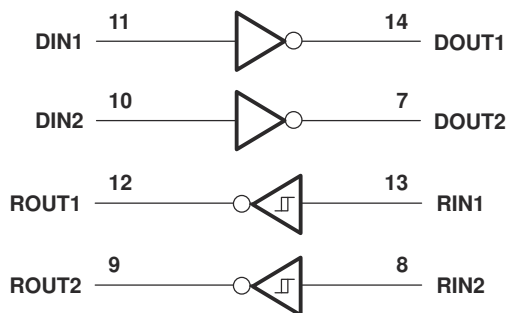

Logic Diagram (Positive Logic)



Table of Contents

1 Features	1	6 Parameter Measurement Information	7
2 Applications	1	7 Detailed Description	8
3 Description	1	7.1 Device Functional Modes.....	8
4 Pin Configuration and Functions	3	8 Application and Implementation	9
5 Specifications	4	8.1 Application Information.....	10
5.1 Absolute Maximum Ratings.....	4	9 Device Documentation and Support	11
5.2 ESD Ratings.....	4	9.1 Receiving Notification of Documentation Updates...	11
5.3 Recommended Operating Conditions.....	4	9.2 Support Resources.....	11
5.4 Thermal Information.....	5	9.3 Trademarks.....	11
5.5 Electrical Characteristics.....	5	9.4 Electrostatic Discharge Caution.....	11
5.6 Driver Section: Electrical Characteristics.....	5	9.5 Glossary.....	11
5.7 Switching Characteristics.....	5	10 Revision History	11
5.8 Receiver Section: Electrical Characteristics.....	6	11 Mechanical, Packaging, and Orderable	
5.9 Switching Characteristics.....	6	Information	11

4 Pin Configuration and Functions

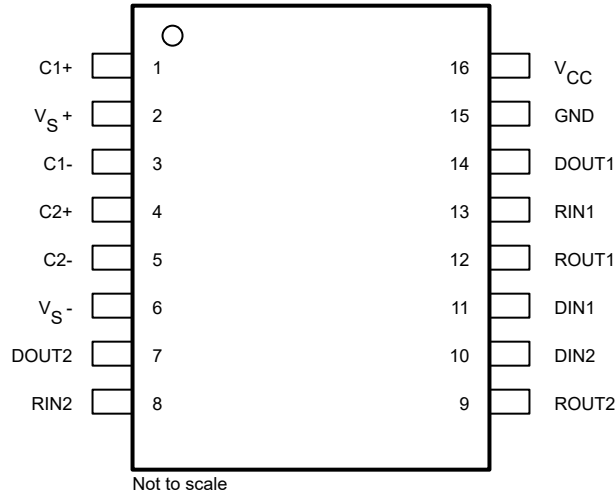

**Figure 4-1. D, DW, N, NS or PW Package
(Top View)**

Table 4-1. Pin Functions

PIN		TYPE	DESCRIPTION
NAME	NO.		
C1+	1	—	Positive lead of C1 capacitor
VS+	2	O	Positive charge pump output for storage capacitor only
C1-	3	—	Negative lead of C1 capacitor
C2+	4	—	Positive lead of C2 capacitor
C2-	5	—	Negative lead of C2 capacitor
VS-	6	O	Negative charge pump output for storage capacitor only
DOUT2	7	O	RS232 line data output (to remote RS232 system)
RIN2	8	I	RS232 line data input (from remote RS232 system)
ROUT2	9	O	Logic data output (to UART)
DIN2	10	I	Logic data input (from UART)
DIN1	11	I	Logic data input (from UART)
ROUT1	12	O	Logic data output (to UART)
RIN1	13	I	RS232 line data input (from remote RS232 system)
DOUT1	14	O	RS232 line data output (to remote RS232 system)
GND	15	—	Ground
VCC	16	—	Supply Voltage, Connect to external 5V power supply

5 Specifications

5.1 Absolute Maximum Ratings

over operating free-air temperature range (unless otherwise noted) ⁽¹⁾

		MIN	MAX	UNIT	
V _{CC}	Input supply voltage range ⁽²⁾	-0.3	6	V	
V _{S+}	Positive output supply voltage range	V _{CC} - 0.3	15	V	
V _{S-}	Negative output supply voltage range	-0.3	-15	V	
V _I	Input voltage range	Driver	-0.3	V _{CC} + 0.3	V
		Receiver		±30	
V _O	Output voltage range	DOUT	V _{S-} - 0.3	V _{S+} + 0.3	V
		ROUT	-0.3	V _{CC} + 0.3	
	Short-circuit duration			Unlimited	
T _J	Operating virtual junction temperature		150	°C	
T _{stg}	Storage temperature range	-65	150	°C	

- (1) Stresses beyond those listed under "absolute maximum ratings" may cause permanent damage to the device. These are stress ratings only, and functional operation of the device at these or any other conditions beyond those indicated under "recommended operating conditions" is not implied. Exposure to absolute-maximum-rated conditions for extended periods may affect device reliability.
- (2) All voltages are with respect to network GND.

5.2 ESD Ratings

PARAMETER	TEST CONDITIONS	TYP	UNIT
DOUT, RIN	HBM	±15	kV
	IEC61000-4-2, Air-Gap Discharge	±15	kV
	IEC61000-4-2, Contact Discharge	±8	kV

5.3 Recommended Operating Conditions

		MIN	NOM	MAX	UNIT
V _{CC}	Supply voltage	4.5	5	5.5	V
V _{IH}	High-level input voltage (DIN1, DIN2)	2			V
V _{IL}	Low-level input voltage (DIN1, DIN2)			0.8	V
	Receiver input voltage (RIN1, RIN2)			±30	V
T _A	Operating free-air temperature	TRS232EC	0	70	°C
		TRS232EI	-40	85	

5.4 Thermal Information

THERMAL METRIC ⁽¹⁾		D (SOIC)	DW (SOIC)	N (PDIP)	PW (TSSOP)	UNIT
		16 PINS	16 PINS	16 PINS	16 PINS	
R _{θJA}	Junction-to-ambient thermal resistance	84.6	71.7	60.6	107.5	°C/W
R _{θJC(top)}	Junction-to-case (top) thermal resistance	43.5	37.4	48.1	38.4	°C/W
R _{θJB}	Junction-to-board thermal resistance	43.2	36.8	40.6	53.7	°C/W
Ψ _{JT}	Junction-to-top characterization parameter	10.4	13.	27.5	3.2	°C/W
Ψ _{JB}	Junction-to-board characterization parameter	42.8	36.4	40.3	53.1	°C/W

(1) For more information about traditional and new thermal metrics, see the [Semiconductor and IC package thermal metrics](#) application report.

5.5 Electrical Characteristics

over recommended ranges of supply voltage and operating free-air temperature (unless otherwise noted) (see ⁽¹⁾ and [Figure 8-1](#))

PARAMETER		TEST CONDITIONS		MIN	TYP ⁽²⁾	MAX	UNIT
I _{CC}	Supply current	V _{CC} = 5.5V,	All outputs open, T _A = 25°C		8	10	mA

- (1) Test conditions are C1–C4 = 1μF at V_{CC} = 5V ± 0.5V.
 (2) All typical values are at V_{CC} = 5V and T_A = 25°C.

5.6 Driver Section: Electrical Characteristics

over recommended ranges of supply voltage and operating free-air temperature range⁽¹⁾

PARAMETER			TEST CONDITIONS		MIN	TYP ⁽²⁾	MAX	UNIT
V _{OH}	High-level output voltage	DOUT	R _L = 3kΩ to GND		5	7		V
V _{OL}	Low-level output voltage ⁽³⁾	DOUT	R _L = 3kΩ to GND			-7	-5	V
r _o	Output resistance	DOUT	V _{S+} = V _{S-} = 0,	V _O = ±2V	300			Ω
I _{OS} ⁽⁴⁾	Short-circuit output current	DOUT	V _{CC} = 5.5V,	V _O = 0		±10		mA
I _{IS}	Short-circuit input current	DIN	V _I = 0				200	μA

- (1) Test conditions are C1–C4 = 1μF at V_{CC} = 5V ± 0.5V.
 (2) All typical values are at V_{CC} = 5V and T_A = 25°C.
 (3) The algebraic convention, in which the least-positive (most negative) value is designated minimum, is used in this data sheet for logic voltage levels only.
 (4) Not more than one output should be shorted at a time.

5.7 Switching Characteristics

V_{CC} = 5 V, T_A = 25°C (see ⁽¹⁾)

PARAMETER		TEST CONDITIONS		MIN	TYP	MAX	UNIT
SR	Driver slew rate	R _L = 3kΩ to 7kΩ, See Figure 6-2				30	V/μs
SR(t)	Driver transition region slew rate	See Figure 6-3			3		V/μs
	Data rate	One DOUT switching			250		kbit/s

- (1) Test conditions are C1–C4 = 1μF at V_{CC} = 5V ± 0.5V.

5.8 Receiver Section: Electrical Characteristics

over recommended ranges of supply voltage and operating free-air temperature range ⁽¹⁾

PARAMETER		TEST CONDITIONS	MIN	TYP ⁽²⁾	MAX	UNIT
V _{OH}	High-level output voltage	ROUT I _{OH} = -1mA	3.5			V
V _{OL}	Low-level output voltage ⁽³⁾	ROUT I _{OL} = 3.2mA			0.4	V
V _{IT+}	Receiver positive-going input threshold voltage	RIN V _{CC} = 5V, T _A = 25°C		1.7	2.4	V
V _{IT-}	Receiver negative-going input threshold voltage	RIN V _{CC} = 5V, T _A = 25°C	0.8	1.2		V
V _{hys}	Input hysteresis voltage	RIN V _{CC} = 5V	0.2	0.5	1	V
r _i	Receiver input resistance	RIN V _{CC} = 5V, T _A = 25°C	3	5	7	kΩ

(1) Test conditions are C1–C4 = 1μF at V_{CC} = 5V ± 0.5V.

(2) All typical values are at V_{CC} = 5V and T_A = 25°C.

(3) The algebraic convention, in which the least-positive (most negative) value is designated minimum, is used in this data sheet for logic voltage levels only.

5.9 Switching Characteristics

V_{CC} = 5 V, T_A = 25°C (see ⁽¹⁾ and [Figure 6-1](#))

PARAMETER		TYP	UNIT
t _{PLH(R)}	Receiver propagation delay time, low- to high-level output	500	ns
t _{PHL(R)}	Receiver propagation delay time, high- to low-level output	500	ns

(1) Test conditions are C1–C4 = 1μF at V_{CC} = 5V ± 0.5V.

6 Parameter Measurement Information

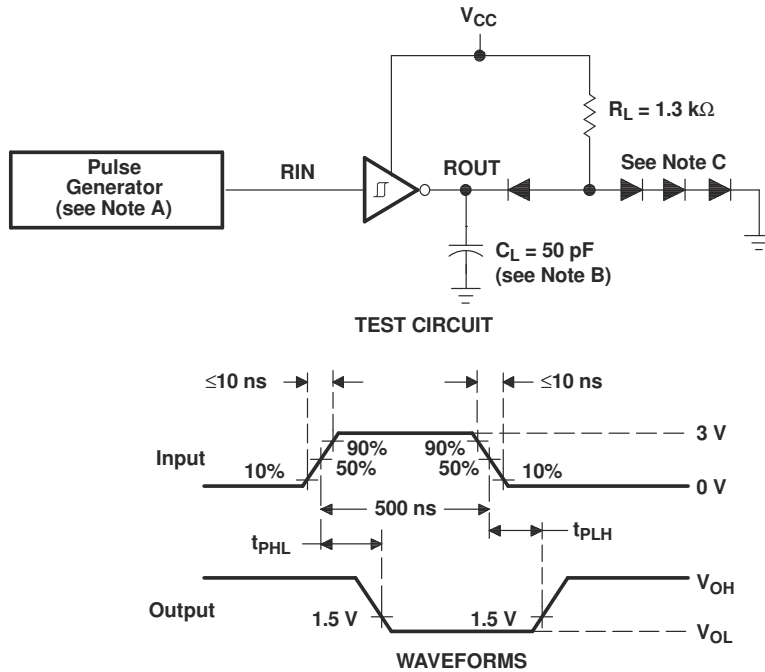

- A. The pulse generator has the following characteristics: $Z_O = 50\Omega$, duty cycle $\leq 50\%$.
- B. C_L includes probe and jig capacitance.
- C. All diodes are 1N3064 or equivalent.

Figure 6-1. Receiver Test Circuit and Waveforms for t_{PHL} and t_{PLH} Measurements

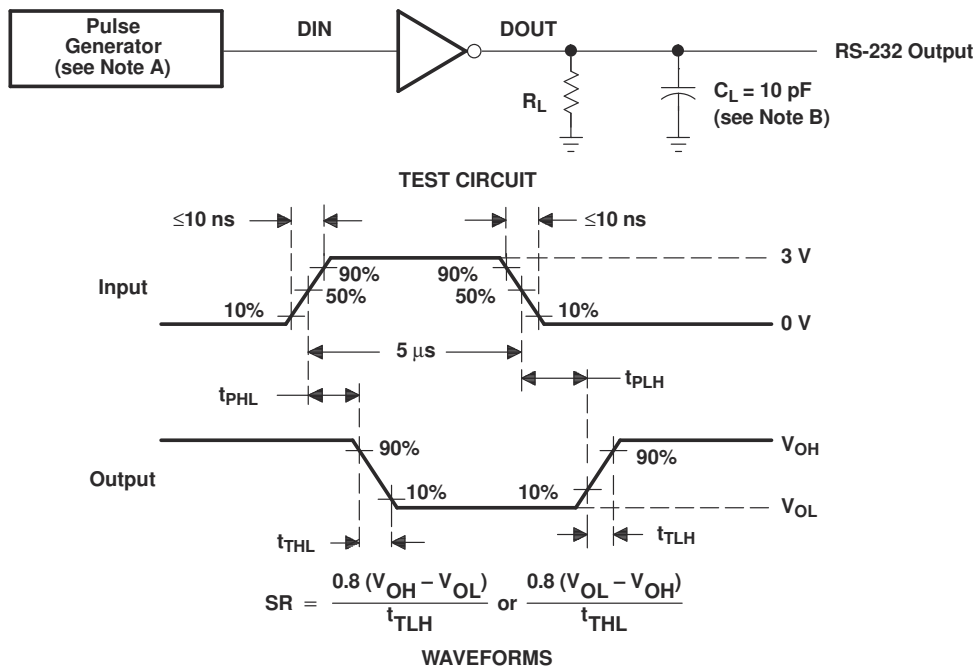

- A. The pulse generator has the following characteristics: $Z_O = 50\Omega$, duty cycle $\leq 50\%$.
- B. C_L includes probe and jig capacitance.

Figure 6-2. Driver Test Circuit and Waveforms for t_{PHL} and t_{PLH} Measurements (5µs Input)

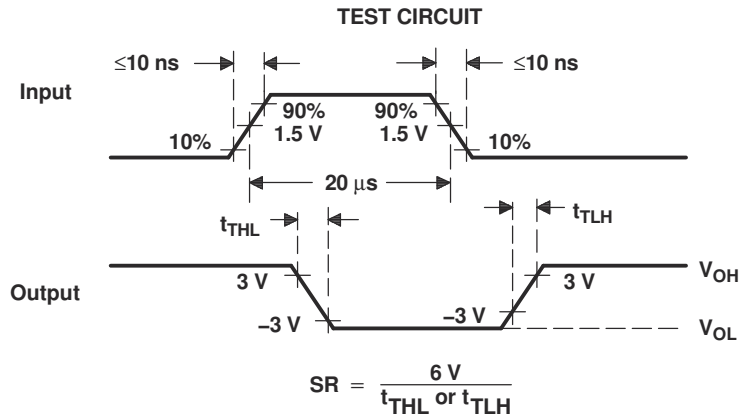
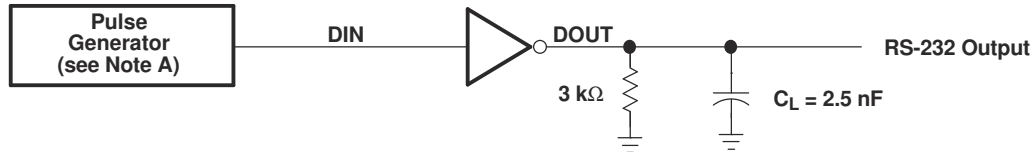

WAVEFORMS

A. The pulse generator has the following characteristics: $Z_O = 50\Omega$, duty cycle $\leq 50\%$.

Figure 6-3. Test Circuit and Waveforms for t_{THL} and t_{TLH} Measurements (20μs Input)

7 Detailed Description

7.1 Device Functional Modes

Table 7-1. Function Tables: Each Driver

INPUT ⁽¹⁾ DIN	OUTPUT DOUT
L	H
H	L

(1) H = high level, L = low level

Table 7-2. Each Receiver

INPUT ⁽¹⁾ RIN	OUTPUT ROUT
L	H
H	L

(1) H = high level, L = low level

8 Application and Implementation

Note

Information in the following applications sections is not part of the TI component specification, and TI does not warrant its accuracy or completeness. TI's customers are responsible for determining suitability of components for their purposes, as well as validating and testing their design implementation to confirm system functionality.

8.1 Application Information

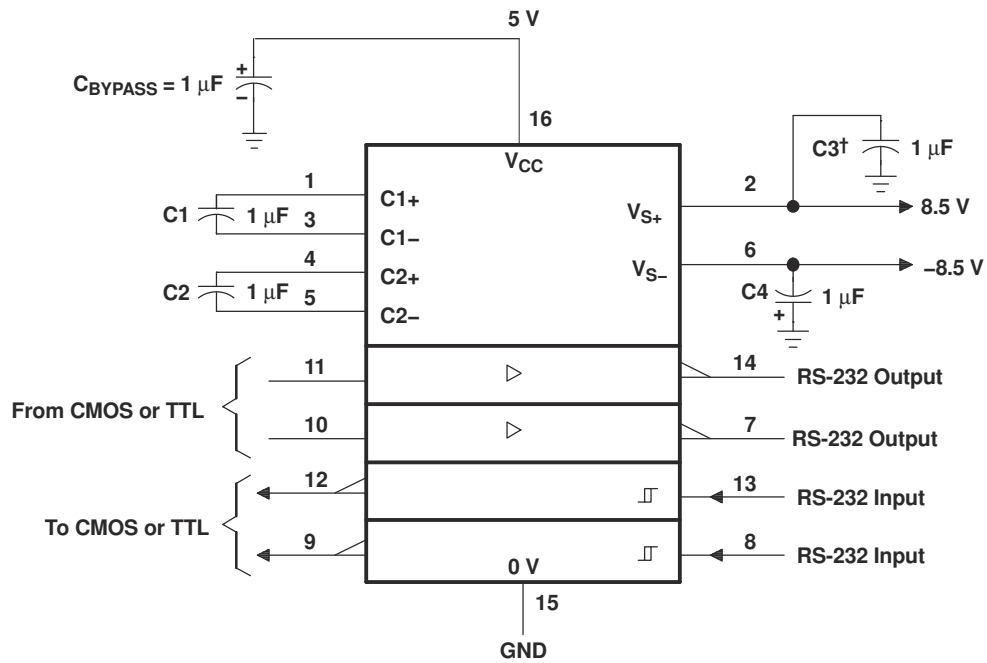

† C3 can be connected to V_{CC} or GND.

- Resistor values shown are nominal.
- Nonpolarized ceramic capacitors are acceptable. If polarized tantalum or electrolytic capacitors are used, they should be connected as shown. In addition to the 1 μF capacitors shown, the TRS202E can operate with 0.1 μF capacitors.

Figure 8-1. Typical Operating Circuit

9 Device Documentation and Support

9.1 Receiving Notification of Documentation Updates

To receive notification of documentation updates, navigate to the device product folder on ti.com. Click on *Notifications* to register and receive a weekly digest of any product information that has changed. For change details, review the revision history included in any revised document.

9.2 Support Resources

[TI E2E™ support forums](#) are an engineer's go-to source for fast, verified answers and design help — straight from the experts. Search existing answers or ask your own question to get the quick design help you need.

Linked content is provided "AS IS" by the respective contributors. They do not constitute TI specifications and do not necessarily reflect TI's views; see TI's [Terms of Use](#).

9.3 Trademarks

LinASIC™ and TI E2E™ are trademarks of Texas Instruments. All trademarks are the property of their respective owners.

9.4 Electrostatic Discharge Caution



This integrated circuit can be damaged by ESD. Texas Instruments recommends that all integrated circuits be handled with appropriate precautions. Failure to observe proper handling and installation procedures can cause damage.

ESD damage can range from subtle performance degradation to complete device failure. Precision integrated circuits may be more susceptible to damage because very small parametric changes could cause the device not to meet its published specifications.

9.5 Glossary

[TI Glossary](#) This glossary lists and explains terms, acronyms, and definitions.

10 Revision History

NOTE: Page numbers for previous revisions may differ from page numbers in the current version.

Changes from Revision C (March 2021) to Revision D (February 2024)	Page
• Changed the numbering format for tables, figures, and cross-references throughout the document.....	1

11 Mechanical, Packaging, and Orderable Information

The following pages include mechanical, packaging, and orderable information. This information is the most current data available for the designated devices. This data is subject to change without notice and revision of this document. For browser-based versions of this data sheet, refer to the left-hand navigation.

PACKAGING INFORMATION

Orderable Device	Status (1)	Package Type	Package Drawing	Pins	Package Qty	Eco Plan (2)	Lead finish/ Ball material (6)	MSL Peak Temp (3)	Op Temp (°C)	Device Marking (4/5)	Samples
TRS232EIDWR	ACTIVE	SOIC	DW	16	2000	RoHS & Green	NIPDAU	Level-1-260C-UNLIM	-40 to 85	TRS232EI	Samples

(1) The marketing status values are defined as follows:

ACTIVE: Product device recommended for new designs.

LIFEBUY: TI has announced that the device will be discontinued, and a lifetime-buy period is in effect.

NRND: Not recommended for new designs. Device is in production to support existing customers, but TI does not recommend using this part in a new design.

PREVIEW: Device has been announced but is not in production. Samples may or may not be available.

OBSELETE: TI has discontinued the production of the device.

(2) **RoHS:** TI defines "RoHS" to mean semiconductor products that are compliant with the current EU RoHS requirements for all 10 RoHS substances, including the requirement that RoHS substance do not exceed 0.1% by weight in homogeneous materials. Where designed to be soldered at high temperatures, "RoHS" products are suitable for use in specified lead-free processes. TI may reference these types of products as "Pb-Free".

RoHS Exempt: TI defines "RoHS Exempt" to mean products that contain lead but are compliant with EU RoHS pursuant to a specific EU RoHS exemption.

Green: TI defines "Green" to mean the content of Chlorine (Cl) and Bromine (Br) based flame retardants meet JS709B low halogen requirements of <=1000ppm threshold. Antimony trioxide based flame retardants must also meet the <=1000ppm threshold requirement.

(3) MSL, Peak Temp. - The Moisture Sensitivity Level rating according to the JEDEC industry standard classifications, and peak solder temperature.

(4) There may be additional marking, which relates to the logo, the lot trace code information, or the environmental category on the device.

(5) Multiple Device Markings will be inside parentheses. Only one Device Marking contained in parentheses and separated by a "-" will appear on a device. If a line is indented then it is a continuation of the previous line and the two combined represent the entire Device Marking for that device.

(6) Lead finish/Ball material - Orderable Devices may have multiple material finish options. Finish options are separated by a vertical ruled line. Lead finish/Ball material values may wrap to two lines if the finish value exceeds the maximum column width.

Important Information and Disclaimer:The information provided on this page represents TI's knowledge and belief as of the date that it is provided. TI bases its knowledge and belief on information provided by third parties, and makes no representation or warranty as to the accuracy of such information. Efforts are underway to better integrate information from third parties. TI has taken and continues to take reasonable steps to provide representative and accurate information but may not have conducted destructive testing or chemical analysis on incoming materials and chemicals. TI and TI suppliers consider certain information to be proprietary, and thus CAS numbers and other limited information may not be available for release.

In no event shall TI's liability arising out of such information exceed the total purchase price of the TI part(s) at issue in this document sold by TI to Customer on an annual basis.

TAPE AND REEL INFORMATION

QUADRANT ASSIGNMENTS FOR PIN 1 ORIENTATION IN TAPE

*All dimensions are nominal

Device	Package Type	Package Drawing	Pins	SPQ	Reel Diameter (mm)	Reel Width W1 (mm)	A0 (mm)	B0 (mm)	K0 (mm)	P1 (mm)	W (mm)	Pin1 Quadrant
TRS232EIDWR	SOIC	DW	16	2000	330.0	16.4	10.75	10.7	2.7	12.0	16.0	Q1

TAPE AND REEL BOX DIMENSIONS

*All dimensions are nominal

Device	Package Type	Package Drawing	Pins	SPQ	Length (mm)	Width (mm)	Height (mm)
TRS232EIDWR	SOIC	DW	16	2000	350.0	350.0	43.0

GENERIC PACKAGE VIEW

DW 16

SOIC - 2.65 mm max height

7.5 x 10.3, 1.27 mm pitch

SMALL OUTLINE INTEGRATED CIRCUIT

This image is a representation of the package family, actual package may vary.
Refer to the product data sheet for package details.

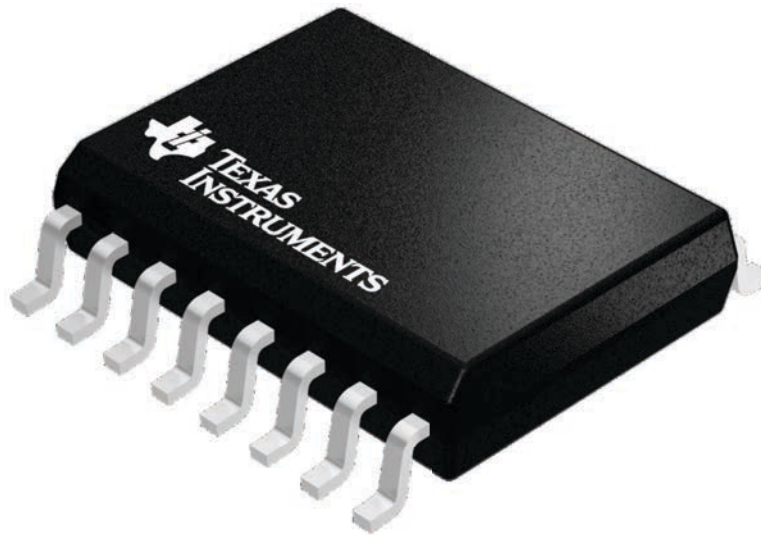

4224780/A

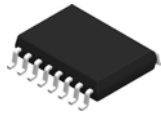

DW0016A

PACKAGE OUTLINE SOIC - 2.65 mm max height

SOIC

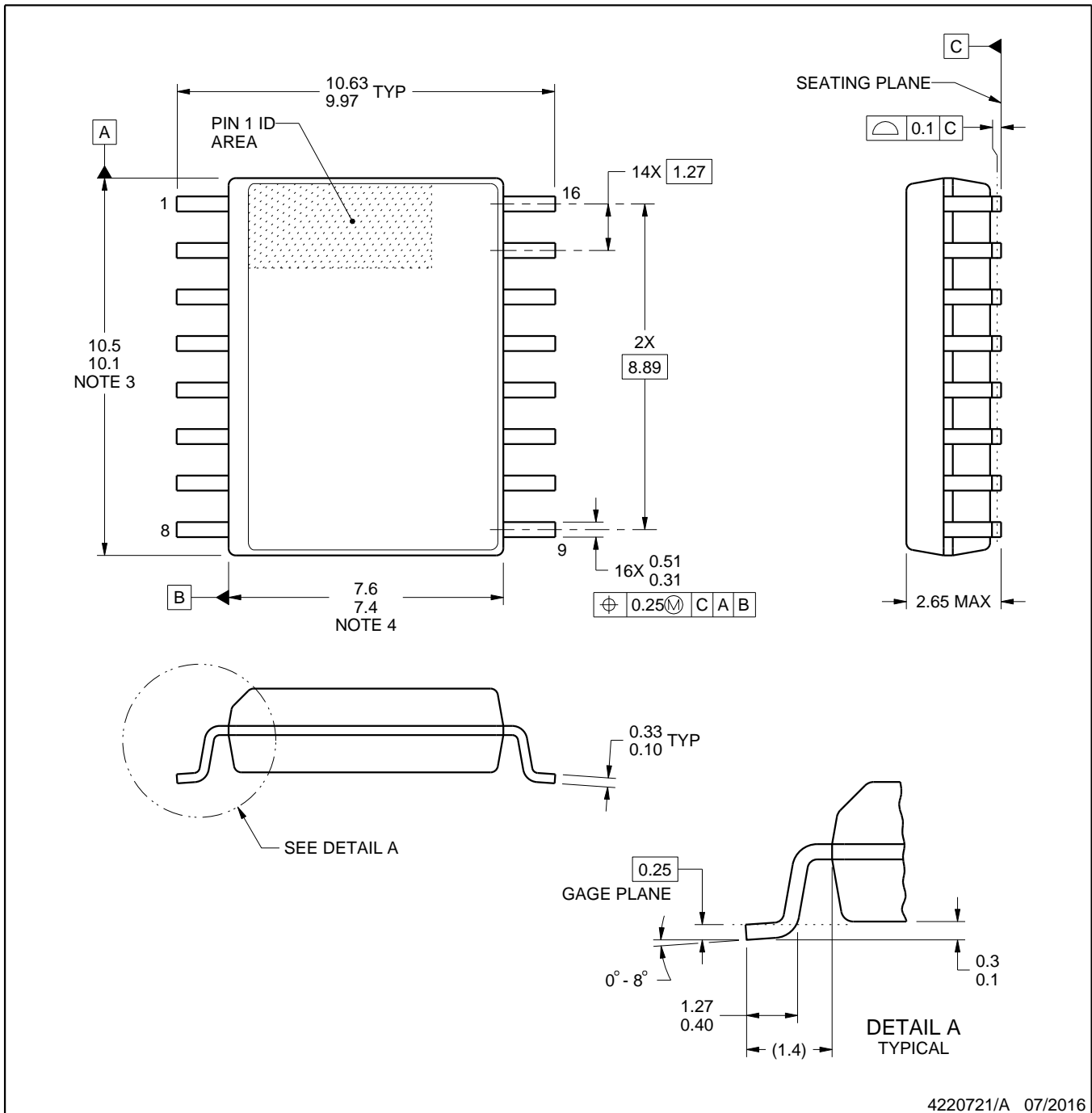

4220721/A 07/2016

NOTES:

1. All linear dimensions are in millimeters. Dimensions in parenthesis are for reference only. Dimensioning and tolerancing per ASME Y14.5M.
2. This drawing is subject to change without notice.
3. This dimension does not include mold flash, protrusions, or gate burrs. Mold flash, protrusions, or gate burrs shall not exceed 0.15 mm, per side.
4. This dimension does not include interlead flash. Interlead flash shall not exceed 0.25 mm, per side.
5. Reference JEDEC registration MS-013.

EXAMPLE BOARD LAYOUT

DW0016A

SOIC - 2.65 mm max height

SOIC

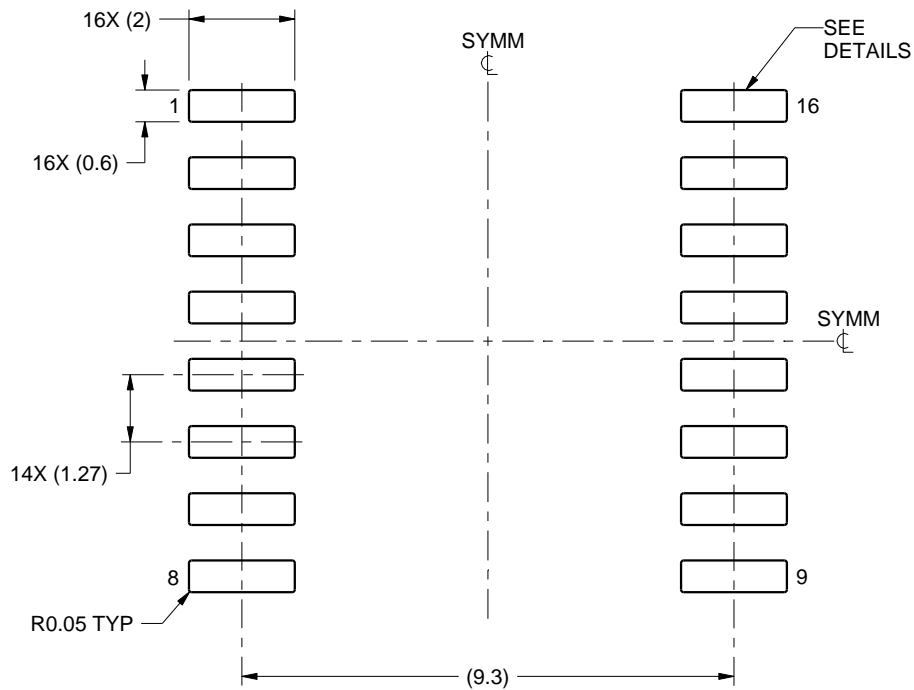

LAND PATTERN EXAMPLE
SCALE:7X

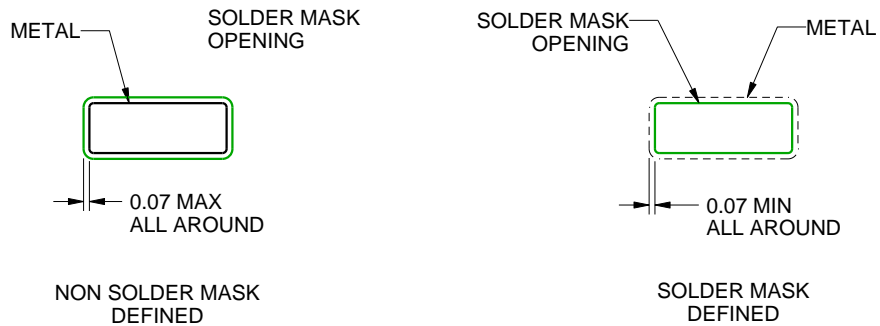

SOLDER MASK DETAILS

4220721/A 07/2016

NOTES: (continued)

6. Publication IPC-7351 may have alternate designs.

7. Solder mask tolerances between and around signal pads can vary based on board fabrication site.

EXAMPLE STENCIL DESIGN

DW0016A

SOIC - 2.65 mm max height

SOIC

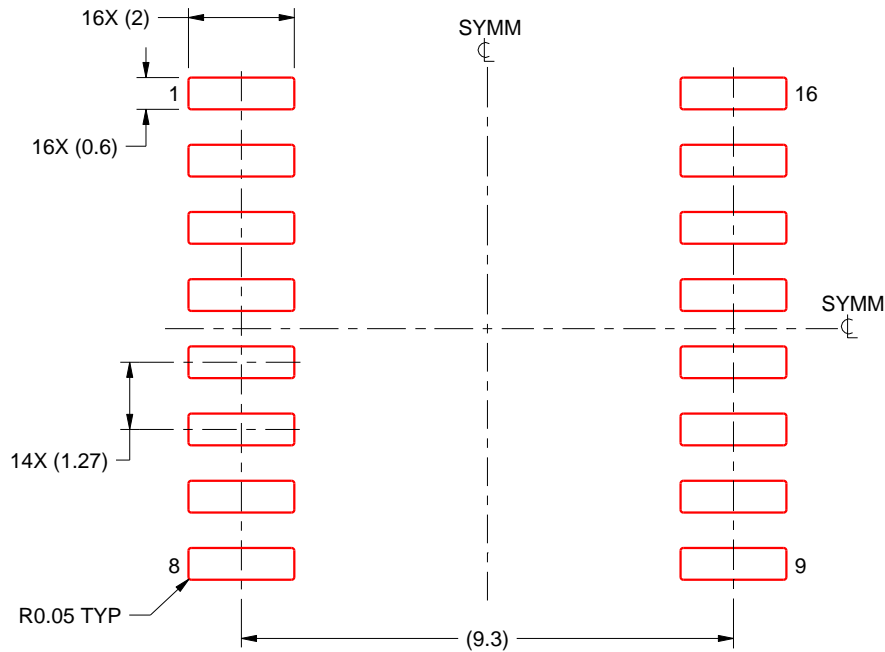

SOLDER PASTE EXAMPLE
BASED ON 0.125 mm THICK STENCIL
SCALE:7X

4220721/A 07/2016

NOTES: (continued)

8. Laser cutting apertures with trapezoidal walls and rounded corners may offer better paste release. IPC-7525 may have alternate design recommendations.
9. Board assembly site may have different recommendations for stencil design.

IMPORTANT NOTICE AND DISCLAIMER

TI PROVIDES TECHNICAL AND RELIABILITY DATA (INCLUDING DATA SHEETS), DESIGN RESOURCES (INCLUDING REFERENCE DESIGNS), APPLICATION OR OTHER DESIGN ADVICE, WEB TOOLS, SAFETY INFORMATION, AND OTHER RESOURCES "AS IS" AND WITH ALL FAULTS, AND DISCLAIMS ALL WARRANTIES, EXPRESS AND IMPLIED, INCLUDING WITHOUT LIMITATION ANY IMPLIED WARRANTIES OF MERCHANTABILITY, FITNESS FOR A PARTICULAR PURPOSE OR NON-INFRINGEMENT OF THIRD PARTY INTELLECTUAL PROPERTY RIGHTS.

These resources are intended for skilled developers designing with TI products. You are solely responsible for (1) selecting the appropriate TI products for your application, (2) designing, validating and testing your application, and (3) ensuring your application meets applicable standards, and any other safety, security, regulatory or other requirements.

These resources are subject to change without notice. TI grants you permission to use these resources only for development of an application that uses the TI products described in the resource. Other reproduction and display of these resources is prohibited. No license is granted to any other TI intellectual property right or to any third party intellectual property right. TI disclaims responsibility for, and you will fully indemnify TI and its representatives against, any claims, damages, costs, losses, and liabilities arising out of your use of these resources.

TI's products are provided subject to [TI's Terms of Sale](#) or other applicable terms available either on [ti.com](https://www.ti.com) or provided in conjunction with such TI products. TI's provision of these resources does not expand or otherwise alter TI's applicable warranties or warranty disclaimers for TI products.

TI objects to and rejects any additional or different terms you may have proposed.

Mailing Address: Texas Instruments, Post Office Box 655303, Dallas, Texas 75265
Copyright © 2024, Texas Instruments Incorporated

Looking for pricing, stock, or lifecycle information?

Click below to explore more details on WIN SOURCE:

 [View TRS232EIPWG4](#) on WIN SOURCE

 [Texas Instruments](#) Information

Optimize Your Supply Chain with WIN SOURCE Solutions

-  Global Sourcing Solution
-  Obsolete Management
-  Cost Control Management
-  Shortage Management
-  Alternative Solution
-  Excess Inventory Management