



**THE DATASHEET OF
TP3054WM-X/63**



Extended Temperature Serial Interface CODEC/Filter COMBO Family

Check for Samples: [TP3054-X](#), [TP3057-X](#)

FEATURES

- **-40°C to +85°C Operation**
- **Complete CODEC and Filtering System (COMBO) Including:**
 - **Transmit High-Pass and Low-Pass Filtering**
 - **Receive Low-Pass Filter with Sin x/x Correction**
 - **Active RC Noise Filters**
 - **μ-Law or A-Law Compatible COder and DECoder**
 - **Internal Precision Voltage Reference**
 - **Serial I/O Interface**
 - **Internal Auto-Zero Circuitry**
- **μ-Law, 16-Pin - TP3054**
- **A-Law, 16-Pin - TP3057**
- **Designed for D3/D4 and CCITT Applications**
- **±5V Operation**
- **Low Operating Power - Typically 50 mW**
- **Power-Down Standby Mode - Typically 3 mW**
- **Automatic Power-Down**
- **TTL or CMOS Compatible Digital Interfaces**
- **Maximizes Line Interface Card Circuit Density**
- **Dual-In-Line or PCC Surface Mount Packages**
- **See also AN-370, “Techniques for Designing with CODEC/Filter COMBO Circuits” ([SNLA136](#))**

DESCRIPTION

The TP3054, TP3057 family consists of μ-law and A-law monolithic PCM CODEC/filters utilizing the A/D and D/A conversion architecture shown in [Figure 3](#), and a serial PCM interface. The devices are fabricated using TI's advanced double-poly CMOS process (microCMOS).

The encode portion of each device consists of an input gain adjust amplifier, an active RC pre-filter which eliminates very high frequency noise prior to entering a switched-capacitor band-pass filter that rejects signals below 200 Hz and above 3400 Hz. Also included are auto-zero circuitry and a companding coder which samples the filtered signal and encodes it in the companded μ-law or A-law PCM format. The decode portion of each device consists of an expanding decoder, which reconstructs the analog signal from the companded μ-law or A-law code, a low-pass filter which corrects for the sin x/x response of the decoder output and rejects signals above 3400 Hz followed by a single-ended power amplifier capable of driving low impedance loads. The devices require two 1.536 MHz, 1.544 MHz or 2.048 MHz transmit and receive master clocks, which may be asynchronous; transmit and receive bit clocks, which may vary from 64 kHz to 2.048 MHz; and transmit and receive frame sync pulses. The timing of the frame sync pulses and PCM data is compatible with both industry standard formats.

Connection Diagram

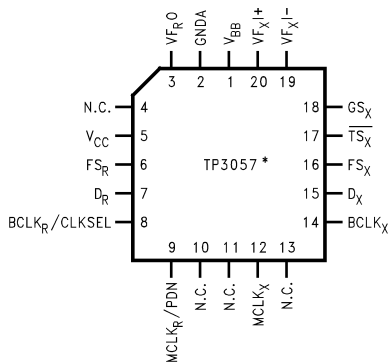

**Figure 1. Plastic Chip Carriers (Top View)
Package Number FN0020A**

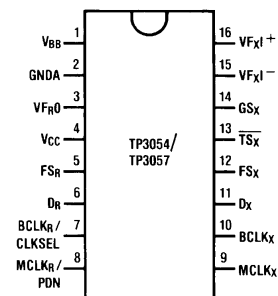

**Figure 2. Dual-In-Line Package (Top View)
Package Number NFG001E & DW0016B**



Please be aware that an important notice concerning availability, standard warranty, and use in critical applications of Texas Instruments semiconductor products and disclaimers thereto appears at the end of this data sheet.

All trademarks are the property of their respective owners.

Block Diagram

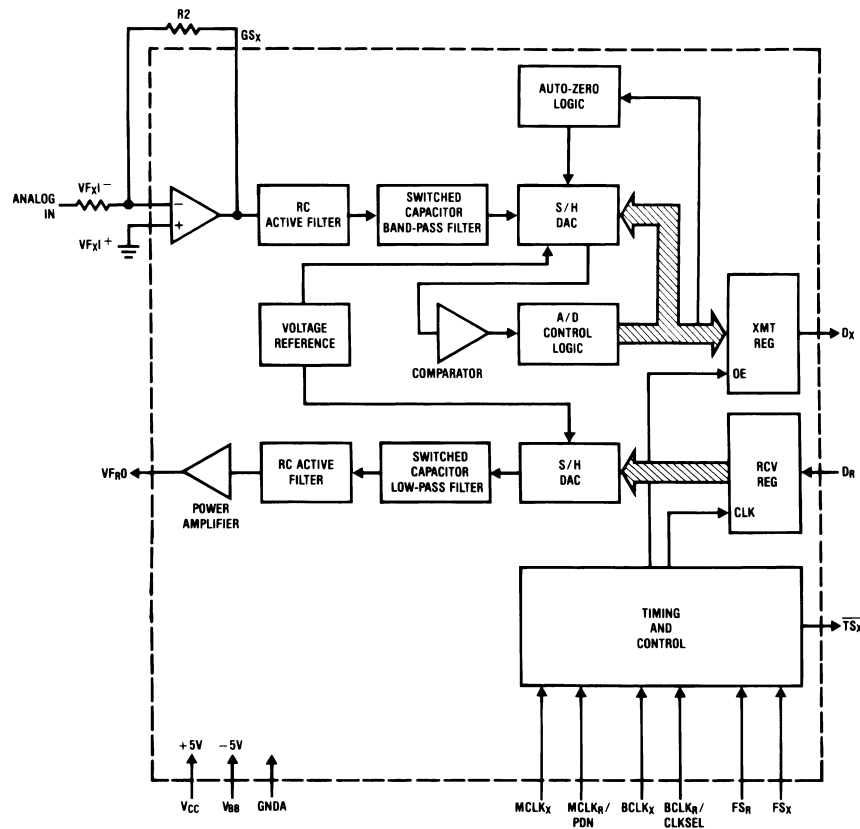

Figure 3.

PIN DESCRIPTIONS

Symbol	Function
V _{BB}	Negative power supply pin. V _{BB} = -5V ±5%.
GND A	Analog ground. All signals are referenced to this pin.
V _{FRO}	Analog output of the receive power amplifier.
V _{CC}	Positive power supply pin. V _{CC} = +5V ±5%.
FS _R	Receive frame sync pulse which enables BCLK _R to shift PCM data into D _R . FS _R is an 8 kHz pulse train. See Figure 4 and Figure 5 for timing details.
D _R	Receive data input. PCM data is shifted into D _R following the FS _R leading edge.
BCLK _R /CLKSEL	The bit clock which shifts data into D _R after the FS _R leading edge. May vary from 64 kHz to 2.048 MHz. Alternatively, may be a logic input which selects either 1.536 MHz/1.544 MHz or 2.048 MHz for master clock in synchronous mode and BCLK _X is used for both transmit and receive directions (see Table 1).
MCLK _R /PDN	Receive master clock. Must be 1.536 MHz, 1.544 MHz or 2.048 MHz. May be asynchronous with MCLK _X , but should be synchronous with MCLK _X for best performance. When MCLK _R is connected continuously low, MCLK _X is selected for all internal timing. When MCLK _R is connected continuously high, the device is powered down.
MCLK _X	Transmit master clock. Must be 1.536 MHz, 1.544 MHz or 2.048 MHz. May be asynchronous with MCLK _R . Best performance is realized from synchronous operation.
FS _X	Transmit frame sync pulse input which enables BCLK _X to shift out the PCM data on D _X . FS _X is an 8 kHz pulse train, see Figure 4 and Figure 5 for timing details.
BCLK _X	The bit clock which shifts out the PCM data on D _X . May vary from 64 kHz to 2.048 MHz, but must be synchronous with MCLK _X .

PIN DESCRIPTIONS (continued)

Symbol	Function
D_X	The TRI-STATE PCM data output which is enabled by FS_X .
\overline{TS}_X	Open drain output which pulses low during the encoder time slot.
GS_X	Analog output of the transmit input amplifier. Used to externally set gain.
VF_{X1}^-	Inverting input of the transmit input amplifier.
VF_{X1}^+	Non-inverting input of the transmit input amplifier.

Functional Description
POWER-UP

When power is first applied, power-on reset circuitry initializes the COMBO and places it into a power-down state. All non-essential circuits are deactivated and the D_X and VF_{RO} outputs are put in high impedance states. To power-up the device, a logical low level or clock must be applied to the $MCLK_R/PDN$ pin and FS_X and/or FS_R pulses must be present. Thus, 2 power-down control modes are available. The first is to pull the $MCLK_R/PDN$ pin high; the alternative is to hold both FS_X and FS_R inputs continuously low—the device will power-down approximately 1 ms after the last FS_X or FS_R pulse. Power-up will occur on the first FS_X or FS_R pulse. The TRI-STATE PCM data output, D_X , will remain in the high impedance state until the second FS_X pulse.

SYNCHRONOUS OPERATION

For synchronous operation, the same master clock and bit clock should be used for both the transmit and receive directions. In this mode, a clock must be applied to $MCLK_X$ and the $MCLK_R/PDN$ pin can be used as a power-down control. A low level on $MCLK_R/PDN$ powers up the device and a high level powers down the device. In either case, $MCLK_X$ will be selected as the master clock for both the transmit and receive circuits. A bit clock must also be applied to $BCLK_X$ and the $BCLK_R/CLKSEL$ can be used to select the proper internal divider for a master clock of 1.536 MHz, 1.544 MHz or 2.048 MHz. For 1.544 MHz operation, the device automatically compensates for the 193rd clock pulse each frame.

With a fixed level on the $BCLK_R/CLKSEL$ pin, $BCLK_X$ will be selected as the bit clock for both the transmit and receive directions. [Table 1](#) indicates the frequencies of operation which can be selected, depending on the state of $BCLK_R/CLKSEL$. In this synchronous mode, the bit clock, $BCLK_X$, may be from 64 kHz to 2.048 MHz, but must be synchronous with $MCLK_X$.

Each FS_X pulse begins the encoding cycle and the PCM data from the previous encode cycle is shifted out of the enabled D_X output on the positive edge of $BCLK_X$. After 8 bit clock periods, the TRI-STATE D_X output is returned to a high impedance state. With an FS_R pulse, PCM data is latched via the D_R input on the negative edge of $BCLK_X$ (or $BCLK_R$ if running). FS_X and FS_R must be synchronous with $MCLK_{X/R}$.

Table 1. Selection of Master Clock Frequencies

$BCLK_R/CLKSEL$	Master Clock	
	Frequency Selected	
	TP3057	TP3054
Clocked	2.048 MHz	1.536 MHz or 1.544 MHz
0	1.536 MHz or 1.544 MHz	2.048 MHz
1	2.048 MHz	1.536 MHz or 1.544 MHz

ASYNCHRONOUS OPERATION

For asynchronous operation, separate transmit and receive clocks may be applied. $MCLK_X$ and $MCLK_R$ must be 2.048 MHz for the TP3057, or 1.536 MHz, 1.544 MHz for the TP3054, and need not be synchronous. For best transmission performance, however, $MCLK_R$ should be synchronous with $MCLK_X$, which is easily achieved by applying only static logic levels to the $MCLK_R$ /PDN pin. This will automatically connect $MCLK_X$ to all internal $MCLK_R$ functions (see Pin Description above). For 1.544 MHz operation, the device automatically compensates for the 193rd clock pulse each frame. FS_X starts each encoding cycle and must be synchronous with $MCLK_X$ and $BCLK_X$. FS_R starts each decoding cycle and must be synchronous with $BCLK_R$. $BCLK_R$ must be a clock, the logic levels shown in [Table 1](#) are not valid in asynchronous mode. $BCLK_X$ and $BCLK_R$ may operate from 64 kHz to 2.048 MHz.

SHORT FRAME SYNC OPERATION

The COMBO can utilize either a short frame sync pulse or a long frame sync pulse. Upon power initialization, the device assumes a short frame mode. In this mode, both frame sync pulses, FS_X and FS_R , must be one bit clock period long, with timing relationships specified in [Figure 4](#). With FS_X high during a falling edge of $BCLK_X$, the next rising edge of $BCLK_X$ enables the D_X TRI-STATE output buffer, which will output the sign bit. The following seven rising edges clock out the remaining seven bits, and the next falling edge disables the D_X output. With FS_R high during a falling edge of $BCLK_R$ ($BCLK_X$ in synchronous mode), the next falling edge of $BCLK_R$ latches in the sign bit. The following seven falling edges latch in the seven remaining bits. All four devices may utilize the short frame sync pulse in synchronous or asynchronous operating mode.

LONG FRAME SYNC OPERATION

To use the long frame mode, both the frame sync pulses, FS_X and FS_R , must be three or more bit clock periods long, with timing relationships specified in [Figure 5](#). Based on the transmit frame sync, FS_X , the COMBO will sense whether short or long frame sync pulses are being used. For 64 kHz operation, the frame sync pulse must be kept low for a minimum of 160 ns. The D_X TRI-STATE output buffer is enabled with the rising edge of FS_X or the rising edge of $BCLK_X$, whichever comes later, and the first bit clocked out is the sign bit. The following seven $BCLK_X$ rising edges clock out the remaining seven bits. The D_X output is disabled by the falling $BCLK_X$ edge following the eighth rising edge, or by FS_X going low, whichever comes later. A rising edge on the receive frame sync pulse, FS_R , will cause the PCM data at D_R to be latched in on the next eight falling edges of $BCLK_R$ ($BCLK_X$ in synchronous mode). All four devices may utilize the long frame sync pulse in synchronous or asynchronous mode.

In applications where the LSB bit is used for signalling, with FS_R two bit clock periods long, the decoder will interpret the lost LSB as “1/2” to minimize noise and distortion.

TRANSMIT SECTION

The transmit section input is an operational amplifier with provision for gain adjustment using two external resistors, see [Figure 8](#). The low noise and wide bandwidth allow gains in excess of 20 dB across the audio passband to be realized. The op amp drives a unity-gain filter consisting of RC active pre-filter, followed by an eighth order switched-capacitor bandpass filter clocked at 256 kHz. The output of this filter directly drives the encoder sample-and-hold circuit. The A/D is of companding type according to μ -law (TP3054) or A-law (TP3057) coding conventions. A precision voltage reference is trimmed in manufacturing to provide an input overload (t_{MAX}) of nominally 2.5V peak (see [Transmission Characteristics](#)). The FS_X frame sync pulse controls the sampling of the filter output, and then the successive-approximation encoding cycle begins. The 8-bit code is then loaded into a buffer and shifted out through D_X at the next FS_X pulse. The total encoding delay will be approximately 165 μ s (due to the transmit filter) plus 125 μ s (due to encoding delay), which totals 290 μ s. Any offset voltage due to the filters or comparator is cancelled by sign bit integration.

RECEIVE SECTION

The receive section consists of an expanding DAC which drives a fifth order switched-capacitor low pass filter clocked at 256 kHz. The decoder is A-law (TP3057) or μ -law (TP3054) and the 5th order low pass filter corrects for the $\sin x/x$ attenuation due to the 8 kHz sample/hold. The filter is then followed by a 2nd order RC active post-filter/power amplifier capable of driving a 600 Ω load to a level of 7.2 dBm. The receive section is unity-gain. Upon the occurrence of FS_R , the data at the D_R input is clocked in on the falling edge of the next eight $BCLK_R$ ($BCLK_X$) periods. At the end of the decoder time slot, the decoding cycle begins, and 10 μ s later the decoder DAC output is updated. The total decoder delay is $\sim 10 \mu$ s (decoder update) plus 110 μ s (filter delay) plus 62.5 μ s ($\frac{1}{2}$ frame), which gives approximately 180 μ s.



These devices have limited built-in ESD protection. The leads should be shorted together or the device placed in conductive foam during storage or handling to prevent electrostatic damage to the MOS gates.

Absolute Maximum Ratings⁽¹⁾⁽²⁾

V_{CC} to GNDA		7V
V_{BB} to GNDA		-7V
Voltage at any Analog Input or Output		$V_{CC}+0.3V$ to $V_{BB}-0.3V$
Voltage at any Digital Input or Output		$V_{CC}+0.3V$ to GNDA-0.3V
Operating Temperature Range		-55°C to + 125°C
Storage Temperature Range		-65°C to +150°C
Lead Temperature	(Soldering, 10 sec.)	300°C

- (1) "Absolute Maximum Ratings" indicate limits beyond which damage to the device may occur. Operating Ratings indicate conditions for which the device is functional, but do not ensure specific performance limits.
- (2) If Military/Aerospace specified devices are required, please contact the Texas Instruments Sales Office/Distributors for availability and specifications.

Electrical Characteristics

Unless otherwise noted, limits printed in **BOLD** characters are ensured for $V_{CC} = +5.0V \pm 5\%$, $V_{BB} = -5.0V \pm 5\%$; $T_A = -40^\circ C$ to $+85^\circ C$ by correlation with 100% electrical testing at $T_A = 25^\circ C$. All other limits are assured by correlation with other production tests and/or product design and characterization. All signals referenced to GNDA. Typicals specified at $V_{CC} = +5.0V$, $V_{BB} = -5.0V$, $T_A = 25^\circ C$.

Symbol	Parameter	Conditions	Min	Typ	Max	Units
DIGITAL INTERFACE						
V_{IL}	Input Low Voltage				0.6	V
V_{IH}	Input High Voltage		2.2			V
V_{OL}	Output Low Voltage	$D_X, I_L=3.2 \text{ mA}$			0.4	V
		$SIG_R, I_L=1.0 \text{ mA}$			0.4	V
		$\overline{TS}_X, I_L=3.2 \text{ mA}, \text{ Open Drain}$			0.4	V
V_{OH}	Output High Voltage	$D_X, I_H=-3.2 \text{ mA}$	2.4			V
		$SIG_R, I_H=-1.0 \text{ mA}$	2.4			V
I_{IL}	Input Low Current	$GNDA \leq V_{IN} \leq V_{IL}$, All Digital Inputs	-10		10	μA
I_{IH}	Input High Current	$V_{IH} \leq V_{IN} \leq V_{CC}$	-10		10	μA
I_{OZ}	Output Current in High Impedance State (TRI-STATE)	$D_X, GNDA \leq V_O \leq V_{CC}$	-10		10	μA
ANALOG INTERFACE WITH TRANSMIT INPUT AMPLIFIER (ALL DEVICES)						
I_{iXA}	Input Leakage Current	$-2.5V \leq V \leq +2.5V, VF_{Xl}^+ \text{ or } VF_{Xl}^-$	-200		200	nA
R_{iXA}	Input Resistance	$-2.5V \leq V \leq +2.5V, VF_{Xl}^+ \text{ or } VF_{Xl}^-$	10			M Ω
R_{oXA}	Output Resistance	Closed Loop, Unity Gain		1	3	Ω
R_{lXA}	Load Resistance	GS_X	10			k Ω
C_{lXA}	Load Capacitance	GS_X			50	pF
V_{oXA}	Output Dynamic Range	$GS_X, R_L \geq 10 \text{ k}\Omega$	-2.8		2.8	V
A_{vXA}	Voltage Gain	$VF_{Xl}^+ \text{ to } GS_X$	5000			V/V

Electrical Characteristics (continued)

Unless otherwise noted, limits printed in **BOLD** characters are ensured for $V_{CC} = +5.0V \pm 5\%$, $V_{BB} = -5.0V \pm 5\%$; $T_A = -40^\circ C$ to $+85^\circ C$ by correlation with 100% electrical testing at $T_A = 25^\circ C$. All other limits are assured by correlation with other production tests and/or product design and characterization. All signals referenced to GNDA. Typical values specified at $V_{CC} = +5.0V$, $V_{BB} = -5.0V$, $T_A = 25^\circ C$.

Symbol	Parameter	Conditions	Min	Typ	Max	Units
F_{UXA}	Unity Gain Bandwidth		1	2		MHz
V_{OSXA}	Offset Voltage		-20		20	mV
V_{CMXA}	Common-Mode Voltage	CMRRXA > 60 dB	-2.5		2.5	V
CMRRXA	Common-Mode Rejection Ratio	DC Test	60			dB
PSRRXA	Power Supply Rejection Ratio	DC Test	60			dB
ANALOG INTERFACE WITH RECEIVE FILTER (ALL DEVICES)						
R_{ORF}	Output Resistance	Pin V_{FO}		1	3	Ω
R_{LRF}	Load Resistance	$V_{FO} = \pm 2.5V$	600			Ω
C_{LRF}	Load Capacitance				500	pF
V_{OSRO}	Output DC Offset Voltage		-200		200	mV
POWER DISSIPATION (ALL DEVICES)						
I_{CC0}	Power-Down Current	No Load ⁽¹⁾		0.65	2.0	mA
I_{BB0}	Power-Down Current	No Load ⁽¹⁾		0.01	0.33	mA
I_{CC1}	Power-Up (Active) Current	No Load		5.0	11.0	mA
I_{BB1}	Power-Up (Active) Current	No Load		5.0	11.0	mA

(1) I_{CC0} and I_{BB0} are measured after first achieving a power-up state.

Timing Specifications

Unless otherwise noted, limits printed in **BOLD** characters are ensured for $V_{CC} = +5.0V \pm 5\%$, $V_{BB} = -5.0V \pm 5\%$; $T_A = -40^\circ C$ to $+85^\circ C$ by correlation with 100% electrical testing at $T_A = 25^\circ C$. All other limits are assured by correlation with other production tests and/or product design and characterization. All signals referenced to GNDA. Typicals specified at $V_{CC} = +5.0V$, $V_{BB} = -5.0V$, $T_A = 25^\circ C$. All timing parameters are assured at $V_{OH} = 2.0V$ and $V_{OL} = 0.7V$. See Definitions and Timing Conventions section for test methods information.

Symbol	Parameter	Conditions	Min	Typ	Max	Units
$1/t_{PM}$	Frequency of Master Clocks	Depends on the Device Used and the		1.536		MHz
		BCLK _R /CLKSEL Pin.		1.544		MHz
		MCLK _X and MCLK _R		2.048		MHz
t_{RM}	Rise Time of Master Clock	MCLK _X and MCLK _R			50	ns
t_{FM}	Fall Time of Master Clock	MCLK _X and MCLK _R			50	ns
t_{PB}	Period of Bit Clock		485	488	15725	ns
t_{RB}	Rise Time of Bit Clock	BCLK _X and BCLK _R			50	ns
t_{FB}	Fall Time of Bit Clock	BCLK _X and BCLK _R			50	ns
t_{WMH}	Width of Master Clock High	MCLK _X and MCLK _R	160			ns
t_{WML}	Width of Master Clock Low	MCLK _X and MCLK _R	160			ns
t_{SBFM}	Set-Up Time from BCLK _X High to MCLK _X Falling Edge	First Bit Clock after the Leading Edge of FS _X	100			ns
		Short Frame Long Frame	125			
t_{SFFM}	Setup Time from FS _X High to MCLK _X Falling Edge	Long Frame Only	100			ns
t_{WBH}	Width of Bit Clock High	$V_{IH}=2.2V$	160			ns
t_{WBL}	Width of Bit Clock Low	$V_{IL}=0.6V$	160			ns
t_{HBFL}	Holding Time from Bit Clock Low to Frame Sync	Long Frame Only	0			ns
t_{HBFS}	Holding Time from Bit Clock High to Frame Sync	Short Frame Only	0			ns
t_{SFB}	Set-Up Time from Frame Sync to Bit Clock Low	Long Frame Only	115			ns
t_{DBD}	Delay Time from BCLK _X High to Data Valid	Load=150 pF plus 2 LSTTL Loads	0		140	ns
t_{DBTS}	Delay Time to \overline{TS}_X Low	Load=150 pF plus 2 LSTTL Loads			140	ns
t_{DZC}	Delay Time from BCLK _X Low to Data Output Disabled	$C_L=0$ pF to 150 pF	50		165	ns
t_{DZF}	Delay Time to Valid Data from FS _X or BCLK _X , Whichever Comes Later	$C_L=0$ pF to 150 pF	20		165	ns
t_{SDB}	Set-Up Time from D _R Valid to BCLK _{R/X} Low		50			ns
t_{HBD}	Hold Time from BCLK _{R/X} Low to D _R Invalid		50			ns
t_{SF}	Set-Up Time from FS _{X/R} to BCLK _{X/R} Low	Short Frame Sync Pulse (1 Bit Clock Period Long)	50			ns
t_{HF}	Hold Time from BCLK _{X/R} Low to FS _{X/R} Low	Short Frame Sync Pulse (1 Bit Clock Period Long)	100			ns
t_{HBF}	Hold Time from 3rd Period of Bit Clock Low to Frame Sync (FS _X or FS _R)	Long Frame Sync Pulse (from 3 to 8 Bit Clock Periods Long)	100			ns
t_{WFL}	Minimum Width of the Frame Sync Pulse (Low Level)	64k Bit/s Operating Mode	160			ns

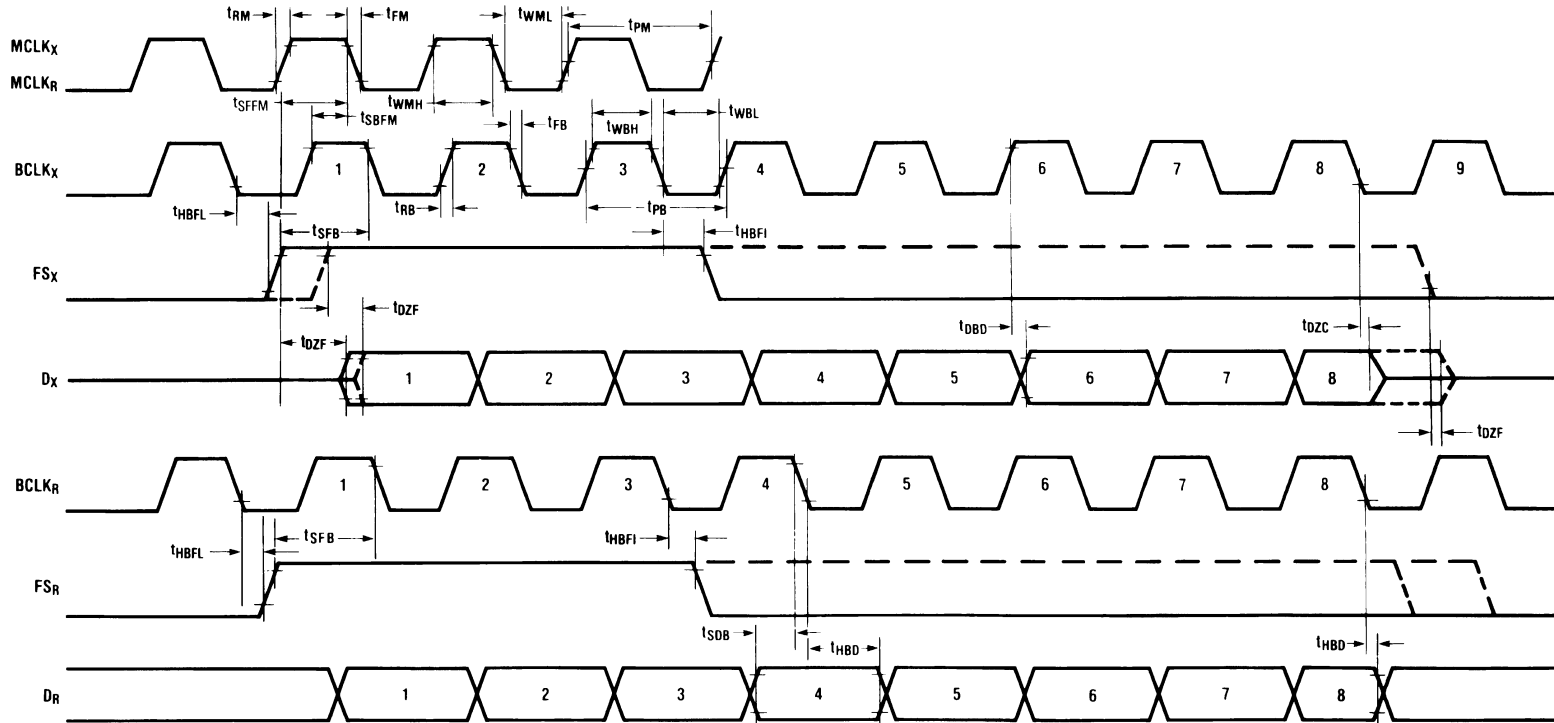

Figure 5. Long Frame Sync Timing

Transmission Characteristics

Unless otherwise noted, limits printed in **BOLD** characters are ensured for $V_{CC} = +5.0V \pm 5\%$, $V_{BB} = -5.0V \pm 5\%$; $T_A = -40^\circ C$ to $+85^\circ C$ by correlation with 100% electrical testing at $T_A = 25^\circ C$. All other limits are assured by correlation with other production tests and/or product design and characterization. $GNDA = 0V$, $f = 1.02 \text{ kHz}$, $V_{IN} = 0 \text{ dBm0}$, transmit input amplifier connected for unity gain non inverting. Typical values are specified at $V_{CC} = +5.0V$, $V_{BB} = -5.0V$, $T_A = 25^\circ C$.

Symbol	Parameter	Conditions	Min	Typ	Max	Units
AMPLITUDE RESPONSE						
	Absolute Levels (Definition of nominal gain)	Nominal 0 dBm0 Level is 4 dBm (600Ω) 0 dBm0		1.2276		V _{rms}
t _{MAX}		Max Overload Level TP3054 (3.17 dBm0) TP3057 (3.14 dBm0)		2.501 2.492		V _{PK} V _{PK}
G _{XA}	Transmit Gain, Absolute	T _A =25°C, V _{CC} =5V, V _{BB} =-5V Input at G _{Sx} =0 dBm0 at 1020 Hz	-0.15		0.15	dB
G _{XR}	Transmit Gain, Relative to G _{XA}	f=16 Hz			-40	dB
		f=50 Hz			-30	dB
		f=60 Hz			-26	dB
		f=200 Hz		-1.8	-0.1	dB
		f=300 Hz–3000 Hz		-0.15	0.15	dB
		f=3152 Hz		-0.15	0.20	dB
		f=3300 Hz		-0.35	0.1	dB
		f=3400 Hz		-0.7	0	dB
		f=4000 Hz			-14	dB
	f=4600 Hz and Up, Measure Response from 0 Hz to 4000 Hz				-32	dB
G _{XAT}	Absolute Transmit Gain Variation with Temperature	Relative to G _{XA}	-0.15		0.15	dB
G _{XAV}	Absolute Transmit Gain Variation with Supply Voltage	Relative to G _{XA}	-0.05		0.05	dB
G _{XRL}	Transmit Gain Variations with Level	Sinusoidal Test Method Reference Level=-10 dBm0 V _{Fx} l ⁺ =-40 dBm0 to +3 dBm0	-0.2		0.2	dB
		V _{Fx} l ⁺ =-50 dBm0 to -40 dBm0	-0.4		0.4	dB
		V _{Fx} l ⁺ =-55 dBm0 to -50 dBm0	-1.2		1.2	dB
G _{RA}	Receive Gain, Absolute	T _A =25°C, V _{CC} =5V, V _{BB} =-5V Input=Digital Code Sequence for 0 dBm0 Signal at 1020 Hz	-0.20		0.20	dB
G _{RR}	Receive Gain, Relative to G _{RA}	f=0 Hz to 3000 Hz	-0.15		0.15	dB
		f=3300 Hz	-0.35		0.1	dB
		f=3400 Hz	-0.7		0	dB
		f=4000 Hz			-14	dB
G _{RAT}	Absolute Receive Gain Variation with Temperature	Relative to G _{RA}	-0.15		0.15	dB
G _{RAV}	Absolute Receive Gain Variation with Supply Voltage	Relative to G _{RA}	-0.05		0.05	dB
G _{RRL}	Receive Gain Variations with Level	Sinusoidal Test Method; Reference Input PCM Code Corresponds to an Ideally Encoded PCM Level ==-40 dBm0 to +3 dBm0	-0.2		0.2	dB
		PCM Level ==-50 dBm0 to -40 dBm0	-0.4		0.4	dB
		PCM Level ==-55 dBm0 to -50 dBm0	-1.2		1.2	dB
V _{RO}	Receive Output Drive Level	R _L =600Ω	-2.5		2.5	V

Transmission Characteristics (continued)

Unless otherwise noted, limits printed in **BOLD** characters are ensured for $V_{CC} = +5.0V \pm 5\%$, $V_{BB} = -5.0V \pm 5\%$; $T_A = -40^\circ C$ to $+85^\circ C$ by correlation with 100% electrical testing at $T_A = 25^\circ C$. All other limits are assured by correlation with other production tests and/or product design and characterization. $GNDA = 0V$, $f = 1.02 \text{ kHz}$, $V_{IN} = 0 \text{ dBm0}$, transmit input amplifier connected for unity gain non inverting. Typical values are specified at $V_{CC} = +5.0V$, $V_{BB} = -5.0V$, $T_A = 25^\circ C$.

Symbol	Parameter	Conditions	Min	Typ	Max	Units
ENVELOPE DELAY DISTORTION WITH FREQUENCY						
D_{XA}	Transmit Delay, Absolute	$f=1600 \text{ Hz}$		290	315	μs
D_{XR}	Transmit Delay, Relative to D_{XA}	$f=500 \text{ Hz}-600 \text{ Hz}$		195	220	μs
		$f=600 \text{ Hz}-800 \text{ Hz}$		120	145	μs
		$f=800 \text{ Hz}-1000 \text{ Hz}$		50	75	μs
		$f=1000 \text{ Hz}-1600 \text{ Hz}$		20	40	μs
		$f=1600 \text{ Hz}-2600 \text{ Hz}$		55	75	μs
		$f=2600 \text{ Hz}-2800 \text{ Hz}$		80	105	μs
D_{RA}	Receive Delay, Absolute	$f=1600 \text{ Hz}$		180	200	μs
		$f=2800 \text{ Hz}-3000 \text{ Hz}$		130	155	μs
D_{RR}	Receive Delay, Relative to D_{RA}	$f=500 \text{ Hz}-1000 \text{ Hz}$	-40	-25		μs
		$f=1000 \text{ Hz}-1600 \text{ Hz}$	-30	-20		μs
		$f=1600 \text{ Hz}-2600 \text{ Hz}$		70	90	μs
		$f=2600 \text{ Hz}-2800 \text{ Hz}$		100	125	μs
		$f=2800 \text{ Hz}-3000 \text{ Hz}$		145	175	μs
NOISE						
N_{XC}	Transmit Noise, C Message Weighted	TP3054 ⁽¹⁾		12	16	dBrnC0
N_{XP}	Transmit Noise, P Message Weighted	TP3057 ⁽¹⁾		-74	-67	dBm0p
N_{RC}	Receive Noise, C Message Weighted	PCM Code is Alternating Positive and Negative Zero - TP3054		8	11	dBrnC0
N_{RP}	Receive Noise, P Message Weighted	TP3057 PCM Code Equals Positive Zero		-82	-79	dBm0p
N_{RS}	Noise, Single Frequency	$f=0 \text{ kHz}$ to 100 kHz , Loop Around Measurement, $V_{F_X I^+} = 0 \text{ Vrms}$			-53	dBm0
$PPSR_X$	Positive Power Supply Rejection, Transmit	$V_{CC}=5.0 V_{DC}+100 \text{ mVrms}$ $f=0 \text{ kHz}-50 \text{ kHz}^{(2)}$	40			dB
$NPSR_X$	Negative Power Supply Rejection, Transmit	$V_{BB}=-5.0 V_{DC}+100 \text{ mVrms}$ $f=0 \text{ kHz}-50 \text{ kHz}^{(2)}$	40			dB
$PPSR_R$	Positive Power Supply Rejection, Receive	PCM Code Equals Positive Zero $V_{CC}=5.0 V_{DC}+100 \text{ mVrms}$ Measure $V_{F_R 0}$ $f=0 \text{ Hz}-4000 \text{ Hz}$	38			dB
		$f=4 \text{ kHz}-25 \text{ kHz}$	38			dB
		$f=25 \text{ kHz}-50 \text{ kHz}$	35			dB
$NPSR_R$	Negative Power Supply Rejection, Receive	PCM Code Equals Positive Zero $V_{BB}=-5.0 V_{DC}+100 \text{ mVrms}$ Measure $V_{F_R 0}$ $f=0 \text{ Hz}-4000 \text{ Hz}$	38			dB
		$f=4 \text{ kHz}-25 \text{ kHz}$	38			dB
		$f=25 \text{ kHz}-50 \text{ kHz}$	35			dB

(1) Measured by extrapolation from the distortion test result at -50 dBm0 .

(2) $PPSR_X$, $NPSR_X$, and CT_{R-X} are measured with a -50 dBm0 activation signal applied to $V_{F_X I^+}$.

Transmission Characteristics (continued)

Unless otherwise noted, limits printed in **BOLD** characters are ensured for $V_{CC} = +5.0V \pm 5\%$, $V_{BB} = -5.0V \pm 5\%$; $T_A = -40^\circ C$ to $+85^\circ C$ by correlation with 100% electrical testing at $T_A = 25^\circ C$. All other limits are assured by correlation with other production tests and/or product design and characterization. $GNDA = 0V$, $f = 1.02\text{ kHz}$, $V_{IN} = 0\text{ dBm0}$, transmit input amplifier connected for unity gain non inverting. Typicals are specified at $V_{CC} = +5.0V$, $V_{BB} = -5.0V$, $T_A = 25^\circ C$.

Symbol	Parameter	Conditions	Min	Typ	Max	Units
SOS	Spurious Out-of-Band Signals at the Channel Output	Loop Around Measurement, 0 dBm0, 300 Hz to 3400 Hz Input PCM Code			-30	dB
		Applied at D_R .				
		4600 Hz–7600 Hz			-30	dB
		7600 Hz–8400 Hz			-40	dB
		8400 Hz–100,000 Hz			-30	dB
DISTORTION						
STD _X , STD _R	Signal to Total Distortion Transmit or Receive Half-Channel	Sinusoidal Test Method ⁽³⁾				
		Level=3.0 dBm0	33			dBC
		=0 dBm0 to -30 dBm0	36			dBC
		=-40 dBm0 XMT	28			dBC
		RCV	29			dBC
=-55 dBm0	XMT	13			dBC	
	RCV	14			dBC	
SFD _X	Single Frequency Distortion, Transmit				-43	dB
SFD _R	Single Frequency Distortion, Receive				-43	dB
IMD	Intermodulation Distortion	Loop Around Measurement, $V_{F_X I^+} = -4\text{ dBm0}$ to -21 dBm0 , Two Frequencies in the Range 300 Hz–3400 Hz			-41	dB
CROSSTALK						
CT _{X-R}	Transmit to Receive Crosstalk, 0 dBm0 Transmit Level	$f=300\text{ Hz}-3400\text{ Hz}$			-90	dB
		$D_R=Quiet\ PCM\ Code^{(4)}$			-70	
CT _{R-X}	Receive to Transmit Crosstalk, 0 dBm0 Receive Level	$f=300\text{ Hz}-3400\text{ Hz}$, $V_{F_X I^+}=Multitone^{(5)}$			-90	-70

(3) TP3054/57 are measured using C message weighted filter for μ -law and psophometric weighted filter for A-law.

(4) CT_{X-R} @ 1.544 MHz $MCLK_X$ freq. is -70 dB max. 50% $\pm 5\%$ $BCLK_X$ duty cycle.

(5) $PPSR_X$, $NPSR_X$, and CT_{R-X} are measured with a -50 dBm0 activation signal applied to $V_{F_X I^+}$.

Encoding Format at D_x Output

	TP3054 μ -Law								TP3057 A-Law (Includes Even Bit Inversion)							
V _{IN} (at GS _x)=+Full-Scale	1	0	0	0	0	0	0	0	1	0	1	0	1	0	1	0
V _{IN} (at GS _x)=0V	1	1	1	1	1	1	1	1	1	1	0	1	0	1	0	1
V _{IN} (at GS _x)=-Full-Scale	0	0	0	0	0	0	0	0	0	1	0	1	0	1	0	1

APPLICATIONS INFORMATION

POWER SUPPLIES

While the pins of the TP3050 family are well protected against electrical misuse, it is recommended that the standard CMOS practice be followed, ensuring that ground is connected to the device before any other connections are made. In applications where the printed circuit board may be plugged into a “hot” socket with power and clocks already present, an extra long ground pin in the connector should be used.

All ground connections to each device should meet at a common point as close as possible to the GNDA pin. This minimizes the interaction of ground return currents flowing through a common bus impedance. 0.1 μ F supply decoupling capacitors should be connected from this common ground point to V_{CC} and V_{BB}, as close to device pins as possible.

For best performance, the ground point of each CODEC/FILTER on a card should be connected to a common card ground in star formation, rather than via a ground bus.

This common ground point should be decoupled to V_{CC} and V_{BB} with 10 μ F capacitors.

RECEIVE GAIN ADJUSTMENT

For applications where a TP3050 family CODEC/filter receive output must drive a 600 Ω load, but a peak swing lower than ± 2.5 V is required, the receive gain can be easily adjusted by inserting a matched T-pad or π -pad at the output. Table 2 lists the required resistor values for 600 Ω terminations. As these are generally non-standard values, the equations can be used to compute the attenuation of the closest practical set of resistors. It may be necessary to use unequal values for the R1 or R4 arms of the attenuators to achieve a precise attenuation. Generally it is tolerable to allow a small deviation of the input impedance from nominal while still maintaining a good return loss. For example a 30 dB return loss against 600 Ω is obtained if the output impedance of the attenuator is in the range 282 Ω to 319 Ω (assuming a perfect transformer).

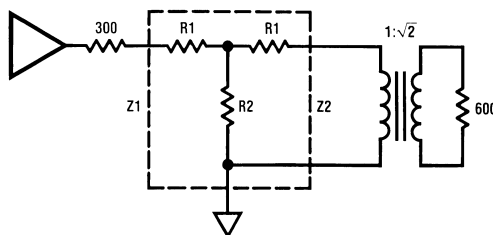

$$R1 = Z1 \left(\frac{N^2 + 1}{N^2 - 1} \right) - 2 \sqrt{Z1 \cdot Z2} \left(\frac{N}{N^2 - 1} \right)$$

$$R2 = 2 \sqrt{Z1 \cdot Z2} \left(\frac{N}{N^2 - 1} \right)$$

Where: $N = \sqrt{\frac{\text{POWER IN}}{\text{POWER OUT}}}$

and

$$S = \sqrt{\frac{Z1}{Z2}}$$

Also: $Z = \sqrt{Z_{SC} \cdot Z_{OC}}$

Where Z_{SC} = impedance with short circuit termination

and Z_{OC} = impedance with open circuit termination

Figure 6. T-Pad Attenuator

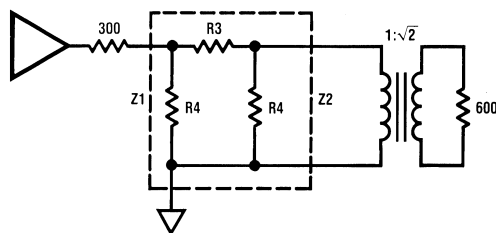

$$R3 = \sqrt{\frac{Z1 \cdot Z2}{2} \left(\frac{N^2 - 1}{N} \right)}$$

$$R3 = Z1 \left(\frac{N^2 - 1}{N^2 - 2NS + 1} \right)$$

Note: See Application Note 370 for further details.

Figure 7. π-Pad Attenuator

Table 2. Attenuator Tables for Z1=Z2=300Ω (All Values in Ω)

dB	R1	R2	R3	R4
0.1	1.7	26k	3.5	52k
0.2	3.5	13k	6.9	26k
0.3	5.2	8.7k	10.4	17.4k
0.4	6.9	6.5k	13.8	13k
0.5	8.5	5.2k	17.3	10.5k
0.6	10.4	4.4k	21.3	8.7k
0.7	12.1	3.7k	24.2	7.5k
0.8	13.8	3.3k	27.7	6.5k
0.9	15.5	2.9k	31.1	5.8k
1.0	17.3	2.6k	34.6	5.2k
2	34.4	1.3k	70	2.6k
3	51.3	850	107	1.8k
4	68	650	144	1.3k
5	84	494	183	1.1k
6	100	402	224	900
7	115	380	269	785
8	379	284	317	698
9	143	244	370	630
10	156	211	427	527
11	168	184	490	535
12	180	161	550	500
13	190	142	635	473
14	200	125	720	450
15	210	110	816	430
16	218	98	924	413
18	233	77	1.17k	386
20	246	61	1.5k	366

Typical Synchronous Application

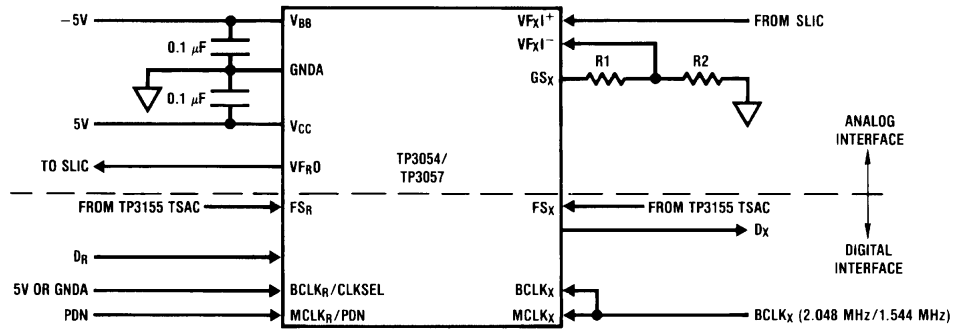

Note 1: XMIT gain = $20 \times \log \left(\frac{R1 + R2}{R2} \right)$, $(R1 + R2) > 10 \text{ K}\Omega$.

Figure 8.

REVISION HISTORY

Changes from Revision B (April 2013) to Revision C	Page
• Changed layout of National Data Sheet to TI format	15

PACKAGING INFORMATION

Orderable Device	Status (1)	Package Type	Package Drawing	Pins	Package Qty	Eco Plan (2)	Lead/Ball Finish (6)	MSL Peak Temp (3)	Op Temp (°C)	Device Marking (4/5)	Samples
TP3054WM-X/63	NRND	SOIC	DW	16	1000	TBD	Call TI	Call TI		TP3054WM-X COMBO\$R	

(1) The marketing status values are defined as follows:

ACTIVE: Product device recommended for new designs.

LIFEBUY: TI has announced that the device will be discontinued, and a lifetime-buy period is in effect.

NRND: Not recommended for new designs. Device is in production to support existing customers, but TI does not recommend using this part in a new design.

PREVIEW: Device has been announced but is not in production. Samples may or may not be available.

OBSOLETE: TI has discontinued the production of the device.

(2) **RoHS:** TI defines "RoHS" to mean semiconductor products that are compliant with the current EU RoHS requirements for all 10 RoHS substances, including the requirement that RoHS substance do not exceed 0.1% by weight in homogeneous materials. Where designed to be soldered at high temperatures, "RoHS" products are suitable for use in specified lead-free processes. TI may reference these types of products as "Pb-Free".

RoHS Exempt: TI defines "RoHS Exempt" to mean products that contain lead but are compliant with EU RoHS pursuant to a specific EU RoHS exemption.

Green: TI defines "Green" to mean the content of Chlorine (Cl) and Bromine (Br) based flame retardants meet JS709B low halogen requirements of <=1000ppm threshold. Antimony trioxide based flame retardants must also meet the <=1000ppm threshold requirement.

(3) MSL, Peak Temp. - The Moisture Sensitivity Level rating according to the JEDEC industry standard classifications, and peak solder temperature.

(4) There may be additional marking, which relates to the logo, the lot trace code information, or the environmental category on the device.

(5) Multiple Device Markings will be inside parentheses. Only one Device Marking contained in parentheses and separated by a "~" will appear on a device. If a line is indented then it is a continuation of the previous line and the two combined represent the entire Device Marking for that device.

(6) Lead/Ball Finish - Orderable Devices may have multiple material finish options. Finish options are separated by a vertical ruled line. Lead/Ball Finish values may wrap to two lines if the finish value exceeds the maximum column width.

Important Information and Disclaimer:The information provided on this page represents TI's knowledge and belief as of the date that it is provided. TI bases its knowledge and belief on information provided by third parties, and makes no representation or warranty as to the accuracy of such information. Efforts are underway to better integrate information from third parties. TI has taken and continues to take reasonable steps to provide representative and accurate information but may not have conducted destructive testing or chemical analysis on incoming materials and chemicals. TI and TI suppliers consider certain information to be proprietary, and thus CAS numbers and other limited information may not be available for release.

In no event shall TI's liability arising out of such information exceed the total purchase price of the TI part(s) at issue in this document sold by TI to Customer on an annual basis.

TAPE AND REEL BOX DIMENSIONS



*All dimensions are nominal

Device	Package Type	Package Drawing	Pins	SPQ	Length (mm)	Width (mm)	Height (mm)
TP3054WM-X/63	SOIC	DW	16	1000	367.0	367.0	38.0

GENERIC PACKAGE VIEW

DW 16

SOIC - 2.65 mm max height

SMALL OUTLINE INTEGRATED CIRCUIT

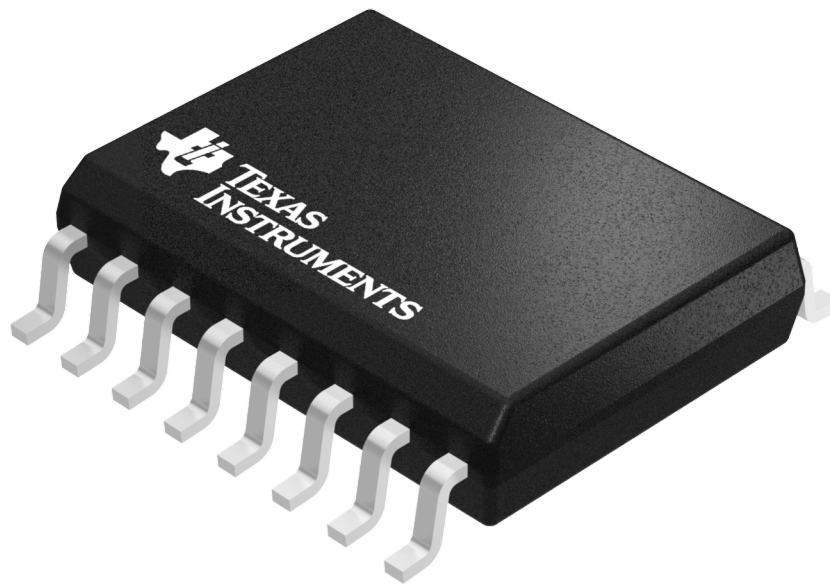

Images above are just a representation of the package family, actual package may vary.
Refer to the product data sheet for package details.

4040000-2/H

IMPORTANT NOTICE AND DISCLAIMER

TI PROVIDES TECHNICAL AND RELIABILITY DATA (INCLUDING DATASHEETS), DESIGN RESOURCES (INCLUDING REFERENCE DESIGNS), APPLICATION OR OTHER DESIGN ADVICE, WEB TOOLS, SAFETY INFORMATION, AND OTHER RESOURCES "AS IS" AND WITH ALL FAULTS, AND DISCLAIMS ALL WARRANTIES, EXPRESS AND IMPLIED, INCLUDING WITHOUT LIMITATION ANY IMPLIED WARRANTIES OF MERCHANTABILITY, FITNESS FOR A PARTICULAR PURPOSE OR NON-INFRINGEMENT OF THIRD PARTY INTELLECTUAL PROPERTY RIGHTS.

These resources are intended for skilled developers designing with TI products. You are solely responsible for (1) selecting the appropriate TI products for your application, (2) designing, validating and testing your application, and (3) ensuring your application meets applicable standards, and any other safety, security, or other requirements. These resources are subject to change without notice. TI grants you permission to use these resources only for development of an application that uses the TI products described in the resource. Other reproduction and display of these resources is prohibited. No license is granted to any other TI intellectual property right or to any third party intellectual property right. TI disclaims responsibility for, and you will fully indemnify TI and its representatives against, any claims, damages, costs, losses, and liabilities arising out of your use of these resources.

TI's products are provided subject to TI's Terms of Sale (www.ti.com/legal/termsofsale.html) or other applicable terms available either on ti.com or provided in conjunction with such TI products. TI's provision of these resources does not expand or otherwise alter TI's applicable warranties or warranty disclaimers for TI products.

Mailing Address: Texas Instruments, Post Office Box 655303, Dallas, Texas 75265
Copyright © 2018, Texas Instruments Incorporated

Looking for pricing, stock, or lifecycle information?

Click below to explore more details on WIN SOURCE:

 [View TP3054WM-X/63 on WIN SOURCE](#)

 [Texas Instruments](#) Information

Optimize Your Supply Chain with WIN SOURCE Solutions

-  Global Sourcing Solution
-  Obsolete Management
-  Cost Control Management
-  Shortage Management
-  Alternative Solution
-  Excess Inventory Management