

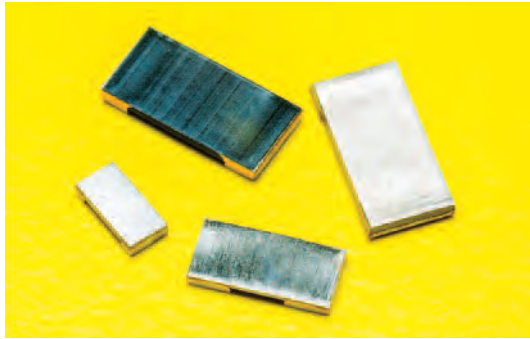

**THE DATASHEET OF
TLR3APDTEL500F75**





features

- Ultra low height with a thickness of 0.6mm, suitable for use of small equipment
- Ultra low resistances (0.5mΩ~), suitable for large current sensing
- Suitable for reflow soldering (Not suitable for flow soldering)
- Products meet EU RoHS requirements
- AEC-Q200 Tested

dimensions and construction

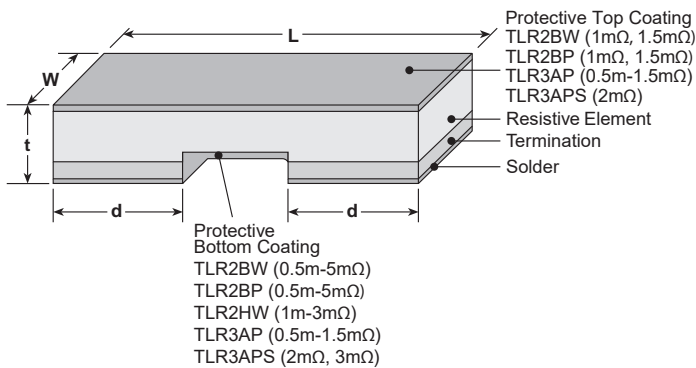

Derating Curve

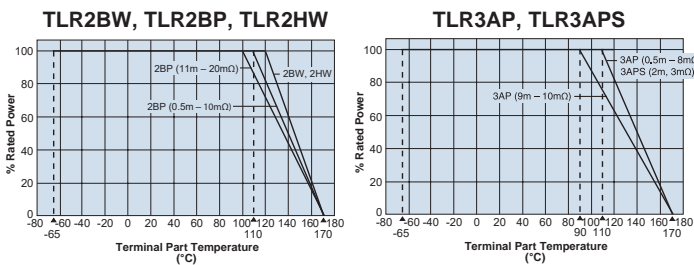

For resistors operated at a terminal part temperature of described for each size or above, a power rating shall be derated in accordance with the derating curve. Please refer to "Introduction of the derating curve based in the terminal part temperature" in the beginning of our catalog before use.

Size Code	Resistance	Dimensions inches (mm)			
		L	W	d	t
TLR2BW	0.5mΩ			.049±.008 (1.25±0.20)	.028±.008 (0.70±0.20)
	1mΩ 1.5mΩ	.126±.008 (3.20±0.20)	.063±.008 (1.60±0.20)	.043±.008 (1.10±0.20)	.024±.008 (0.60±0.20)
	2mΩ - 20mΩ			.020±.008 (0.50±0.20)	
TLR2BP	0.5mΩ			.049±.008 (1.25±0.20)	.028±.008 (0.70±0.20)
	1mΩ, 1.5mΩ	.126±.008 (3.20±0.20)	.063±.008 (1.60±0.20)	.043±.008 (1.10±0.20)	.024±.008 (0.60±0.20)
	2mΩ - 20mΩ			.020±.008 (0.50±0.20)	
TLR2HW	0.5mΩ			.075±.008 (1.90±0.20)	.028±.008 (0.70±0.20)
	1mΩ	.200±.008 (5.00±0.20)	.100±.008 (2.50±0.20)	.071±.008 (1.80±0.20)	.026±.008 (0.65±0.20)
	1.5mΩ				
	2mΩ - 6mΩ 7mΩ - 10mΩ			.060±.008 (1.50±0.20) .020±.008 (0.50±0.20)	.024±.008 (0.60±0.20)
TLR3AP	0.5mΩ			.107±.01 (2.725±0.25)	.024±.01 (0.60±0.25)
	0.68mΩ, 0.75mΩ, 0.82mΩ			.105±.01 (2.675±0.25)	
	1mΩ, 1.5mΩ, 3mΩ, 4mΩ	.25±.01 (6.35±0.25)	.125±.01 (3.18±0.25)	.087±.01 (2.20±0.25)	
	2mΩ			.098±.01 (2.50±0.25)	
	5mΩ, 6mΩ, 7mΩ, 8mΩ			.047±.01 (1.20±0.25)	
	9mΩ, 10mΩ			.030±.01 (0.77±0.25)	
TLR3APS	2mΩ, 3mΩ	.25±.01 (6.35±0.25)	.125±.01 (3.18±0.25)	.047±.01 (1.20±0.25)	.024±.01 (0.60±0.25)

ordering information

TLR	2BW	D	TD	10L0	F	75
Type	Power Rating	Termination Material	Packaging	Nominal Resistance	Tolerance	T.C.R.
	2BW: 1W 2BP: 1.5W, 3W 2HW: 2W 3AP: 3W, 5W 3APS: 3W	D: SnAgCu	TD: 7" 4mm pitch punched paper TE: 7" 4mm embossed plastic	±1%: 4 digits All values less than 0.1Ω (100m) are expressed in mΩ with "L" as decimal Ex: 2mΩ = 2L00	F: ±1%	50: 50ppm/°C 75: 75ppm/°C

For further information on packaging, please refer to Appendix A.

Specifications given herein may be changed at any time without prior notice. Please confirm technical specifications before you order and/or use.

11/28/22

applications and ratings

current sense

Part Designation	Power Rating	T.C.R. (ppm/°C) Max.	Standard Resistance (Ω)	Resistance Tolerance	Rated Terminal Part Temperature	Operating Temperature Range
TLR2BW	1W	±50	2m, 3m, 4m, 5m, 6m, 7m, 8m, 9m, 10m, 11m, 12m, 13m, 15m, 16m, 18m, 20m	F: ±1%	+120°C and less	-65°C to +170°C
		±75	0.5m, 1m, 1.5m, 2m, 3m, 4m, 5m, 6m, 7m, 8m, 9m, 10m, 11m, 12m, 13m, 15m, 16m, 18m, 20m			
TLR2BP	1.5W	±50	5m, 6m, 7m, 8m, 9m, 10m 11m, 12m, 13m, 15m, 16m, 18m, 20m	F: ±1%	+110°C and less	-65°C to +170°C
		±75	5m, 6m, 7m, 8m, 9m, 10m 11m, 12m, 13m, 15m, 16m, 18m, 20m		+100°C and less	
	3W	±50	2m, 3m, 4m	F: ±1%	+110°C and less	
		±75	0.5m, 1m, 1.5m, 2m, 3m, 4m		+100°C and less	
TLR2HW	2W	±50 ±75	0.5m, 1m, 1.5m, 2m, 2.5m, 3m, 4m, 5m, 6m, 7m, 8m, 9m, 10m	F: ±1%	+120°C and less	-65°C to +170°C
TLR3AP	3W	±50	5m, 6m, 7m, 8m, 9m, 10m	F: ±1%	5m ~ 8m: +110°C and less	-65°C to +170°C
		±75			9m, 10m: +90°C and less	
	5W	±50	2m, 3m, 4m	F: ±1%	0.5m~1m, 2m~4m: +110°C and less	-65°C to +170°C
		±75	0.5m, 0.68m, 0.75m, 0.82m, 1m, 1.5m, 2m, 3m, 4m		1.5m: +90°C and less	
TLR3APS	3W	±50, ±75	2m, 3m	F: ±1%	+110°C and less	-65°C to +170°C

environmental applications

One-Pulse Limiting Electric Power

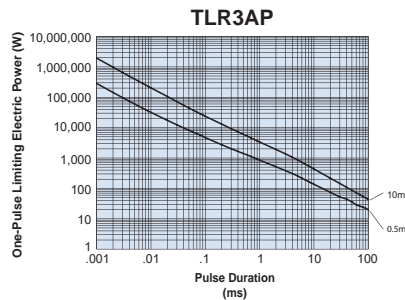
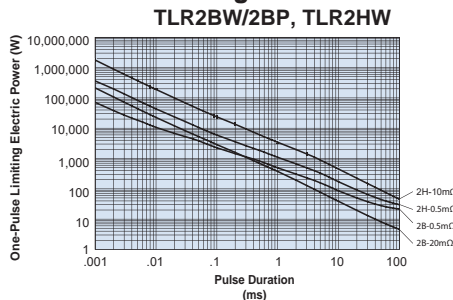

Please ask us about the resistance characteristic of continuous applied pulse. The pulse endurance values are not assured values, so be sure to check the products on actual equipment when you use them.

Thermal Resistance

Type	Size	Resistance (Ω)	Rth (°C/W)
TLR	2BW/2BP	0.5m	7.2
		20m	116
	2HW	0.5m	9
		10m	61.1
	3AP	0.5m	6
		10m	62

$$R_{th} = (H_s - t_s) / \text{Power}$$

Regarding the temperature rise, the value of the temperature varies per conditions and board for use since the temperature is measured under our measuring conditions. Please refer to us before use.

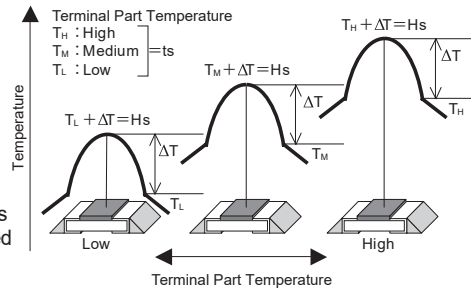

The temperature of the resistor will increase the same ΔT from the standard terminal part temperature regardless of the ambient temperature when the same power is applied. This is because there is hardly any heat dissipation from the resistor surface to the ambient air.

Performance Characteristics

Parameter	Requirement $\Delta R \pm\%$		Test Method
	Limit	Typical	
Resistance	Within regulated tolerance	—	25°C
T.C.R.	Within specified T.C.R.	—	+25°C/+125°C
Resistance to Solder Heat	±0.5%	±0.3%	260°C ± 5°C, 10 ± 2 seconds
Rapid Change of Temperature	±0.5%	±0.3%	-55°C (15 minutes), +150°C (15 minutes), 1000 cycles
Moisture Resistance	±0.5%	±0.1%	MIL-STD-202-106, 0% power, 7a and 7b not required
Biased Humidity	±0.5%	±0.1%	85°C ± 2°C, 85% RH, 1000 hours, 10% bias
Endurance of Rated Terminal Part Temperature	±1.0%	±0.3%	120°C ± 2°C (2BW, 2HW), 110°C ± 2°C (3AP 0.5m~1mΩ, 2m~8mΩ) 90°C ± 2°C (3AP 1.5mΩ, 9mΩ~10mΩ), 110°C ± 2°C (2BP 0.5mΩ~10mΩ) 100°C ± 2°C (2BP 11mΩ~20mΩ), 110°C ± 2°C (3APS 2mΩ, 3mΩ) 1000 hours, 1.5 hr ON, 0.5 hr OFF cycle
High Temperature Exposure	±1.0%	±0.6%	±155°C, 1000 hours
	±2.0%	±0.8%	±170°C, 1000 hours

Specifications given herein may be changed at any time without prior notice. Please confirm technical specifications before you order and/or use.

7/21/23

Looking for pricing, stock, or lifecycle information?

Click below to explore more details on WIN SOURCE:

 [View TLR3APDTEL500F75 on WIN SOURCE](#)

 [KOA Speer Information](#)

Optimize Your Supply Chain with WIN SOURCE Solutions

-  Global Sourcing Solution
-  Obsolete Management
-  Cost Control Management
-  Shortage Management
-  Alternative Solution
-  Excess Inventory Management