

TIBPAL20L8-10C, TIBPAL20R4-10C, TIBPAL20R6-10C, TIBPAL20R8-10C HIGH-PERFORMANCE *IMPACT-X*™ PAL® CIRCUITS

SRPS008A – D3336, OCTOBER 1989 – REVISED MARCH 1992

- **High-Performance Operation:**
 f_{max} (no feedback)
 TIBPAL20R' . . . 71.4 MHz
 f_{max} (internal feedback)
 TIBPAL20R' . . . 58.8 MHz
 f_{max} (external feedback)
 TIBPAL20R' . . . 55.5 MHz
 Propagation Delay
 TIBPAL20' . . . 10 ns Max
- **Functionally Equivalent, but Faster Than Existing 24-Pin PLD Circuits**
- **Preload Capability on Output Registers Simplifies Testing**
- **Power-Up Clear on Registered Devices (All Register Outputs are Set Low, but Voltage Levels at the Output Pins Go High)**
- **Package Options Include Plastic Chip Carriers in Addition to Plastic and Ceramic DIPs**
- **Security Fuse Prevents Duplication**
- **Dependable Texas Instruments Quality and Reliability**

DEVICE	I INPUTS	3-STATE O OUTPUTS	REGISTERED Q OUTPUTS	I/O PORTS
PAL20L8	14	2	0	6
PAL20R4	12	0	4 (3-state buffers)	4
PAL20R6	12	0	6 (3-state buffers)	2
PAL20R8	12	0	8 (3-state buffers)	0

description

These programmable array logic devices feature high speed and functional equivalency when compared with currently available devices. These *IMPACT-X*™ circuits combine the latest Advanced Low-Power Schottky technology with proven titanium-tungsten fuses to provide reliable, high-performance substitutes for conventional TTL logic. Their easy programmability allows for quick design of custom functions and typically results in a more compact circuit board. In addition, chip carriers are available for further reduction in board space.

All of the register outputs are set to a low level during power up. Extra circuitry has been provided to allow loading of each register asynchronously to either a high or low state. This feature simplifies testing because the registers can be set to an initial state prior to executing the test sequence.

The TIBPAL20' C series is characterized from 0°C to 75°C.

TIBPAL20L8'
JT OR NT PACKAGE
(TOP VIEW)

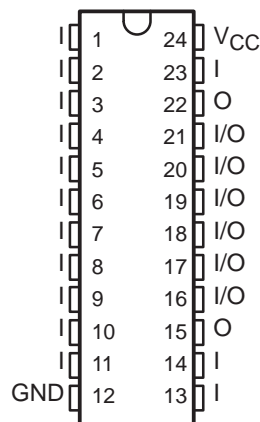

TIBPAL20L8'
FN PACKAGE
(TOP VIEW)

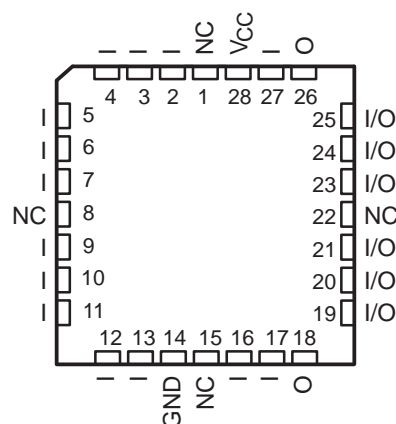

NC — No internal connection
Pin assignments in operating mode

These devices are covered by U.S. Patent 4,410,987.
IMPACT-X is a trademark of Texas Instruments Incorporated.
 PAL is a registered trademark of Advanced Micro Devices Inc.

PRODUCTION DATA information is current as of publication date. Products conform to specifications per the terms of Texas Instruments standard warranty. Production processing does not necessarily include testing of all parameters.



POST OFFICE BOX 655303 • DALLAS, TEXAS 75265

Copyright © 1992, Texas Instruments Incorporated

TIBPAL20L8-10C, TIBPAL20R4-10C HIGH-PERFORMANCE *IMPACT-X*™ PAL® CIRCUITS

SRPS008A – D3336, OCTOBER 1989 – REVISED MARCH 1992

functional block diagrams (positive logic)

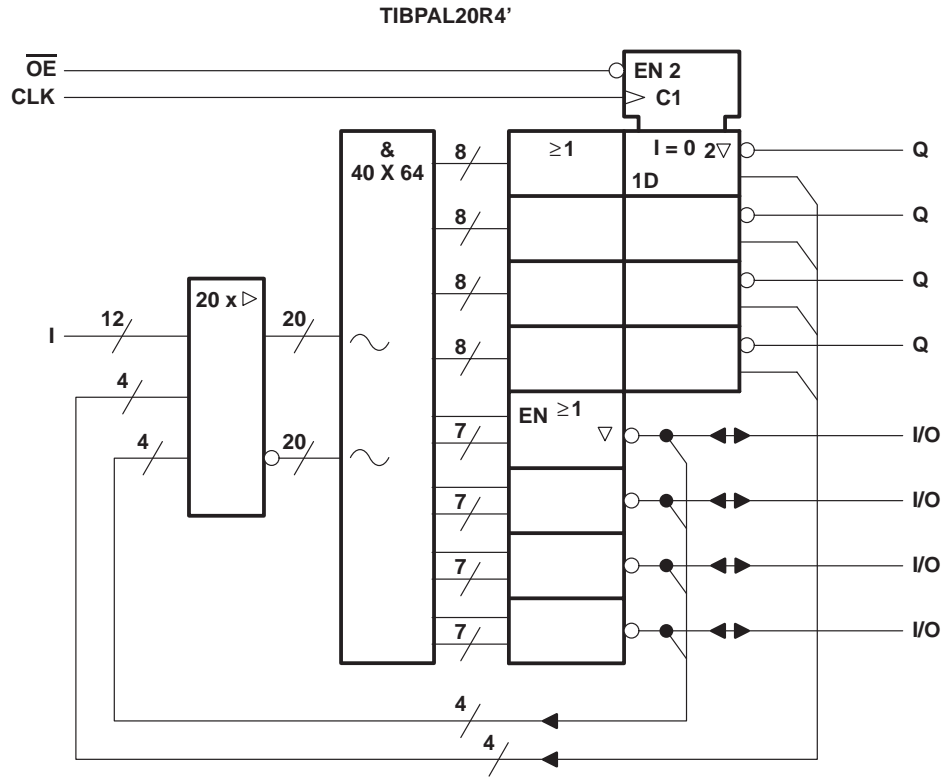
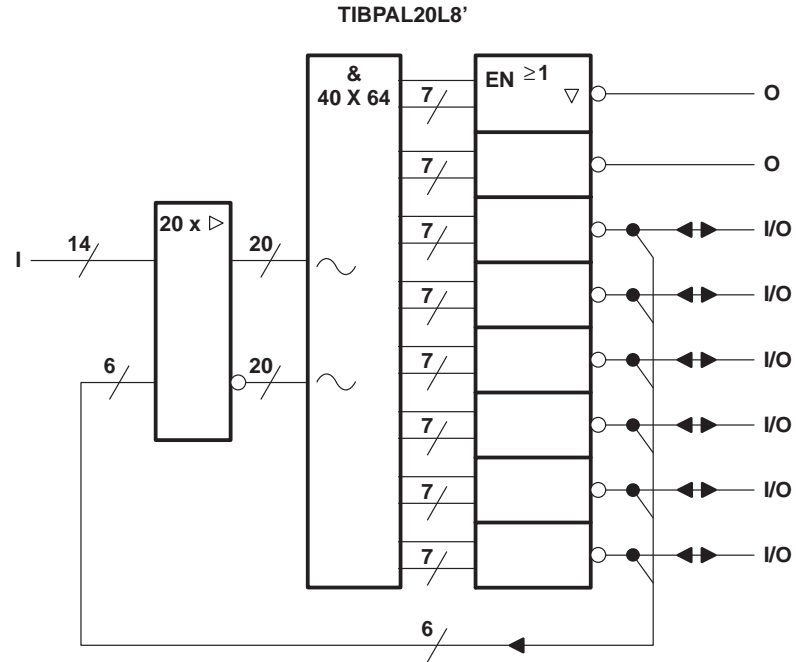

~ denotes fused inputs

TIBPAL20R6-10C, TIBPAL20R8-10C HIGH-PERFORMANCE *IMPACT-X*™ PAL® CIRCUITS

SRPS008A – D3336, OCTOBER 1989 – REVISED MARCH 1992

functional block diagrams (positive logic)

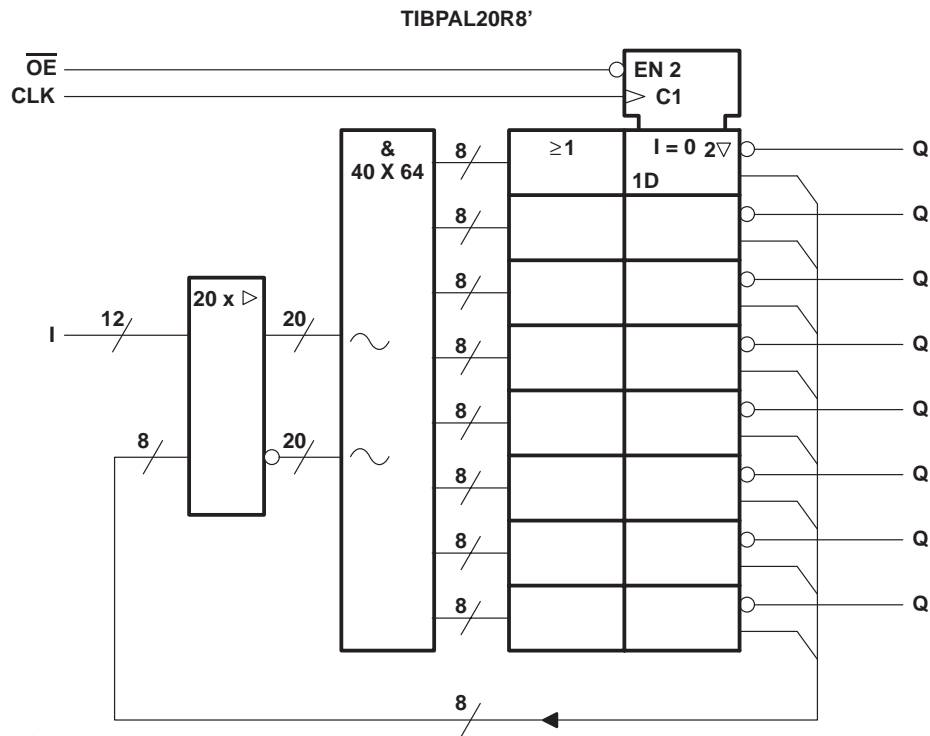
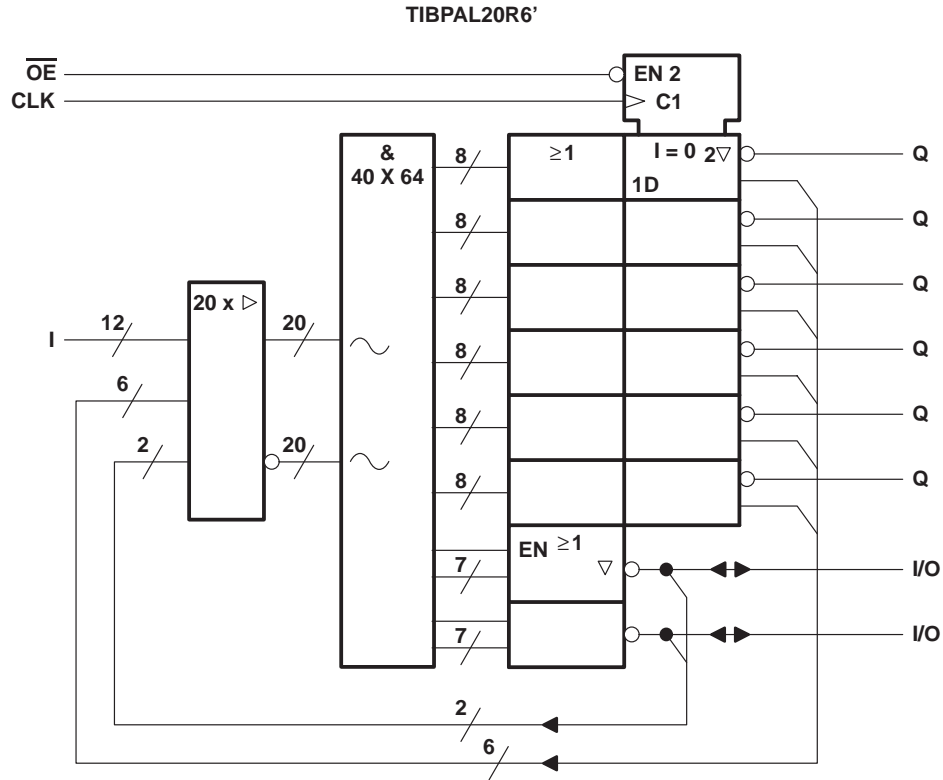

~ denotes fused inputs



POST OFFICE BOX 655303 • DALLAS, TEXAS 75265

logic diagram (positive logic)

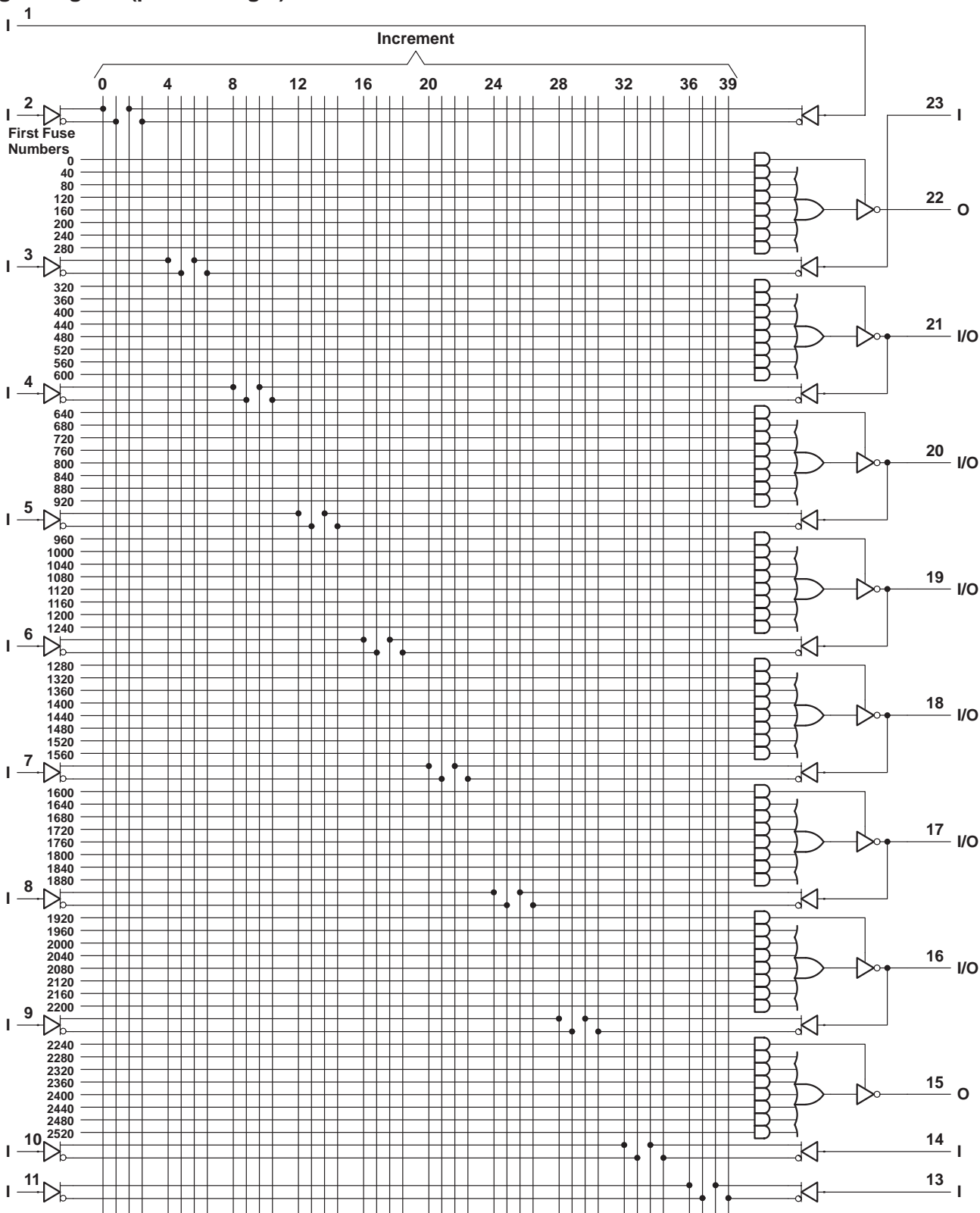

Fuse number = First fuse number + Increment
Pin numbers shown are for JT and NT packages.

TIBPAL20R4-10C HIGH-PERFORMANCE *IMPACT-X*™ PAL® CIRCUITS

SRPS008A – D3336, OCTOBER 1989 – REVISED MARCH 1992

logic diagram (positive logic)

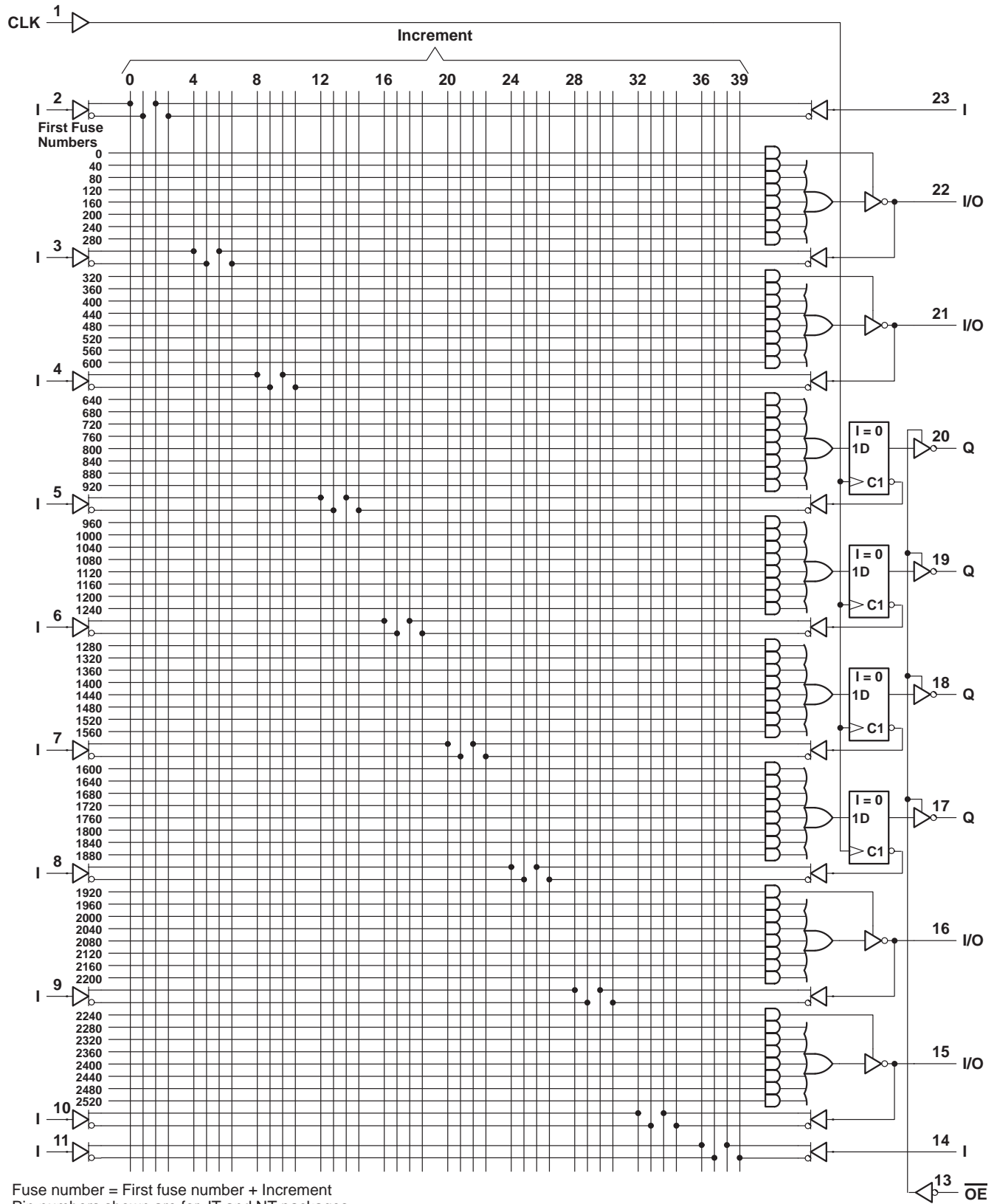

logic diagram (positive logic)

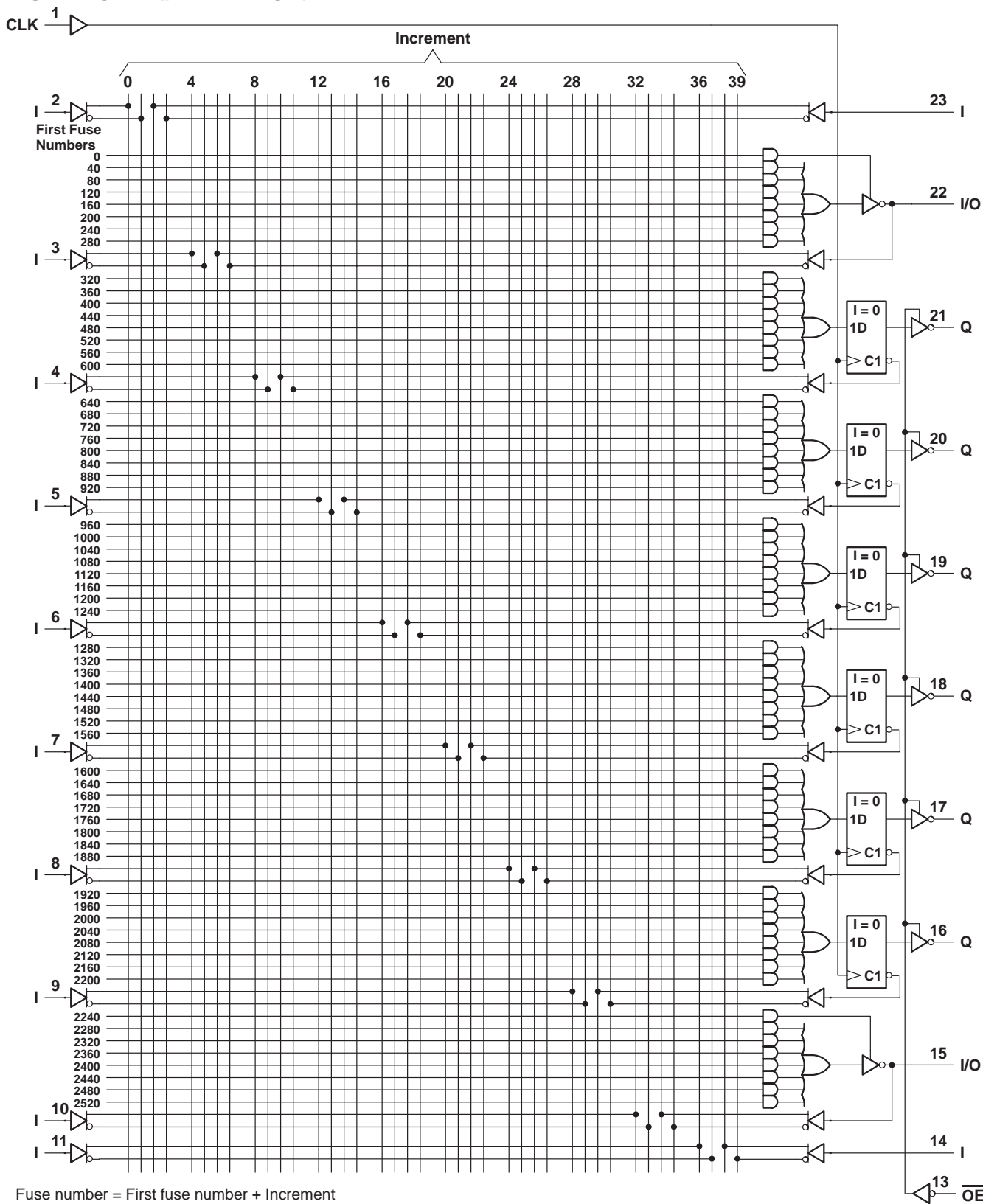

Fuse number = First fuse number + Increment
Pin numbers shown are for JT and NT packages.



TIBPAL20R8-10C HIGH-PERFORMANCE *IMPACT-X*™ PAL® CIRCUITS

SRPS008A – D3336, OCTOBER 1989 – REVISED MARCH 1992

logic diagram (positive logic)

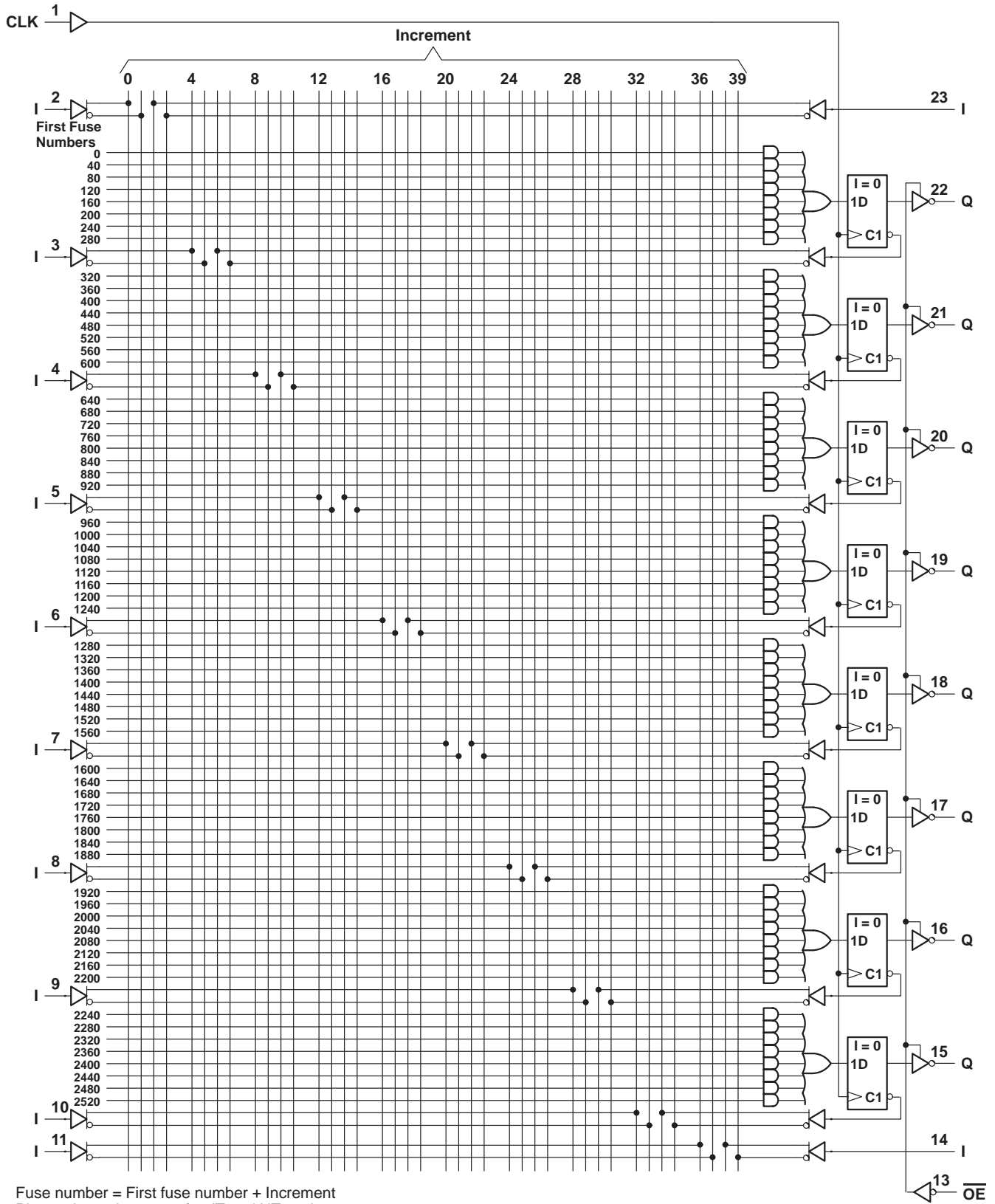

Fuse number = First fuse number + Increment
Pin numbers shown are for JT and NT packages.



POST OFFICE BOX 655303 • DALLAS, TEXAS 75265

TIBPAL20L8-10C, TIBPAL20R4-10C, TIBPAL20R6-10C, TIBPAL20R8-10C HIGH-PERFORMANCE *IMPACT-X*[™] PAL[®] CIRCUITS

SRPS008A – D3336, OCTOBER 1989 – REVISED MARCH 1992

absolute maximum ratings over operating free-air temperature range (unless otherwise noted)

Supply voltage, V_{CC} (see Note 1)	7 V
Input voltage (see Note 1)	5.5 V
Voltage applied to disabled output (see Note 1)	5.5 V
Operating free-air temperature range	0°C to 75°C
Storage temperature range	–65°C to 150°C

NOTE 1: These ratings apply except for programming pins during a programming cycle.

recommended operating conditions

		MIN	NOM	MAX	UNIT
V_{CC}	Supply voltage	4.75	5	5.25	V
V_{IH}	High-level input voltage	2		5.5	V
V_{IL}	Low-level input voltage			0.8	V
I_{OH}	High-level output current			–3.2	mA
I_{OL}	Low-level output current			24	mA
f_{clock}^{\dagger}	Clock frequency	0		71.4	MHz
t_w^{\dagger}	Pulse duration, clock (see Note 2)	High		7	ns
		Low		7	
t_{su}^{\dagger}	Setup time, input or feedback before clock \uparrow	10			ns
t_h^{\dagger}	Hold time, input or feedback after clock \uparrow	0			ns
T_A	Operating free-air temperature	0	25	75	°C

$^{\dagger} f_{clock}$, t_w , t_{su} , and t_h do not apply for TIBPAL20L8'.

NOTE 2: These are absolute voltage levels with respect to the ground pin of the device and include all overshoots due to system and/or tester noise. Testing these parameters should not be attempted without suitable equipment.



TIBPAL20L8-10C, TIBPAL20R4-10C, TIBPAL20R6-10C, TIBPAL20R8-10C HIGH-PERFORMANCE *IMPACT-X*™ *PAL*® CIRCUITS

SRPS008A – D3336, OCTOBER 1989 – REVISED MARCH 1992

electrical characteristics over recommended operating free-air temperature range

PARAMETER		TEST CONDITIONS		MIN	TYP†	MAX	UNIT
V _{IK}		V _{CC} = 4.75 V,	I _I = -18 mA		-0.8	-1.5	V
V _{OH}		V _{CC} = 4.75 V,	I _{OH} = -3.2 mA	2.4			V
V _{OL}		V _{CC} = 4.75 V,	I _{OL} = 24 mA		0.3	0.5	V
I _{OZH} ‡	O, Q outputs	V _{CC} = 5.25 V,	V _O = 2.7 V			20	μA
	I/O ports					100	
I _{OZL} ‡	O, Q outputs	V _{CC} = 5.25 V,	V _O = 0.4 V			-20	μA
	I/O ports					-100	
I _I		V _{CC} = 5.25 V,	V _I = 5.5 V			0.2	mA
I _{IH} ‡		V _{CC} = 5.25 V,	V _I = 2.7 V			25	μA
I _{IL} ‡		V _{CC} = 5.25 V,	V _I = 0.4 V			-0.25	mA
I _{OS} §		V _{CC} = 5.25 V,	V _O = 0.5 V	-30	-70	-130	mA
I _{CC}		V _{CC} = 5.25 V, Outputs open,	V _I = 0, OE = V _{IH}			210	mA
C _i		f = 1 MHz,	V _I = 2 V		7		pF
C _o		f = 1 MHz,	V _O = 2 V		8		pF
C _{clk}		f = 1 MHz,	V _{CLK} = 2 V		12		pF

switching characteristics over recommended ranges of supply voltage and operating free-air temperature (unless otherwise noted)

PARAMETER	FROM (INPUT)	TO (OUTPUT)	TEST CONDITION	MIN	TYP†	MAX	UNIT	
f _{max} ¶	without feedback		R1 = 200 Ω, R2 = 390 Ω, See Figure 6	71.4			MHz	
	with internal feedback (counter configuration)			58.8				
	with external feedback			55.5				
t _{pd}	I, I/O	O, I/O			3	8	10	
t _{pd}	CLK↑	Q			2	5	8	ns
t _{pd} #	CLK↑	Feedback input					7	ns
t _{en}	OE↓	Q			2	6	10	ns
t _{dis}	OE↑	Q			2	6	10	ns
t _{en}	I, I/O	O, I/O			3	8	10	ns
t _{dis}	I, I/O	O, I/O			2	8	10	ns
t _{sk(o)}	Skew between registered outputs				0.5		ns	

† All typical values are at V_{CC} = 5 V, T_A = 25°C.

‡ I/O leakage is the worst case of I_{OZL} and I_{IL} or I_{OZH} and I_{IH} respectively.

§ Not more than one output should be shorted at a time, and the duration of the short circuit should not exceed one second. V_O is set at 0.5 V to avoid test problems caused by test equipment ground degradation.

¶ See section for f_{max} specifications. f_{max} does not apply for TIBPAL20L8'.

This parameter applies to TIBPAL20R4' and TIBPAL20R6' only (see Figure 4 for illustration) and is calculated from the measured f_{max} with internal feedback in the counter configuration.

|| This parameter is the measurement of the difference between the fastest and slowest t_{pd} (CLK-to-Q) observed when multiple registered outputs are switching in the same direction.



programming information

Texas Instruments programmable logic devices can be programmed using widely available software and inexpensive device programmers.

Complete programming specifications, algorithms, and the latest information on hardware, software, and firmware are available upon request. Information on programmers capable of programming Texas Instruments programmable logic is also available, upon request, from the nearest TI field sales office, local authorized TI distributor, or by calling Texas Instruments at (214) 997-5666.

preload procedure for registered outputs (see Figure 1 and Note 3)

The output registers can be preloaded to any desired state during device testing. This permits any state to be tested without having to step through the entire state-machine sequence. Each register is preloaded individually by following the steps given below.

- Step 1. With V_{CC} at 5 volts and Pin 1 at V_{IL} , raise Pin 13 to V_{IHH} .
- Step 2. Apply either V_{IL} or V_{IH} to the output corresponding to the register to be preloaded.
- Step 3. Pulse Pin 1, clocking in preload data.
- Step 4. Remove output voltage, then lower Pin 13 to V_{IL} . Preload can be verified by observing the voltage level at the output pin.

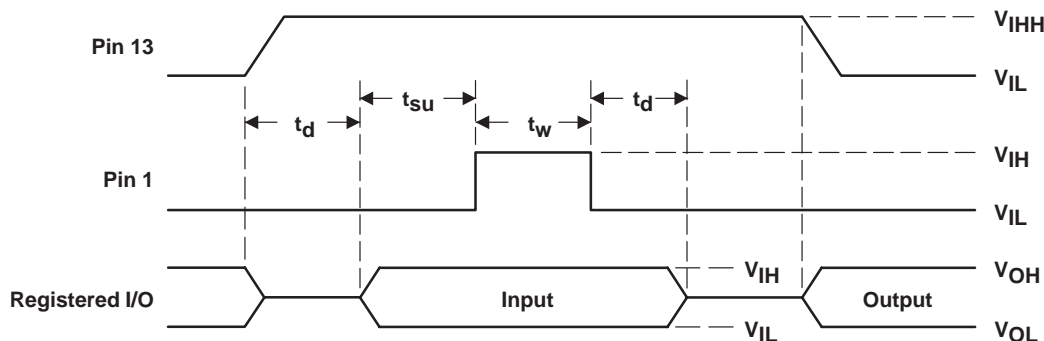
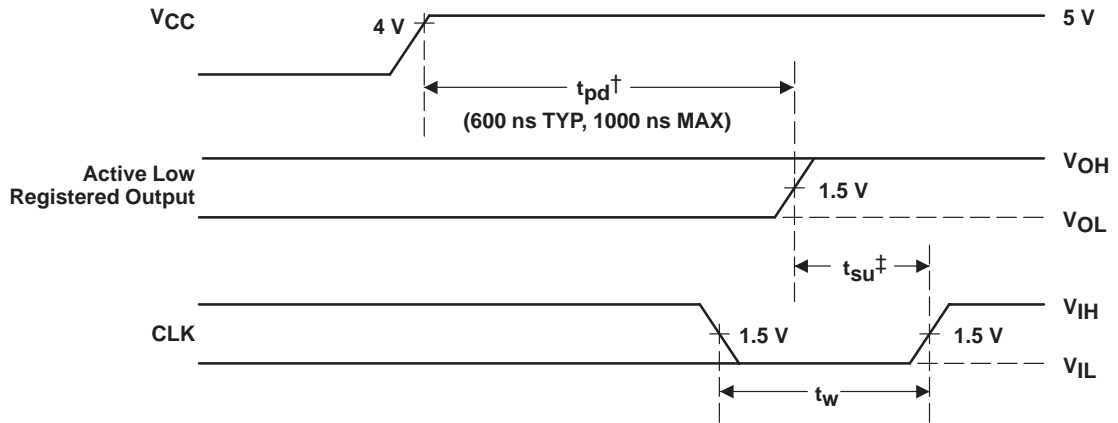

Figure 1. Preload Waveforms

NOTE 3: $t_d = t_{su} = t_h = 100$ ns to 1000 ns $V_{IHH} = 10.25$ V to 10.75 v

power-up reset (see Figure 2)

Following power up, all registers are reset to zero. This feature provides extra flexibility to the system designer and is especially valuable in simplifying state-machine initialization. To ensure a valid power-up reset, it is important that the rise of V_{CC} be monotonic. Following power-up reset, a low-to-high clock transition must not occur until all applicable input and feedback setup times are met.



† This is the power-up reset time and applies to registered outputs only. The values shown are from characterization data.
 ‡ This is the setup time for input or feedback.

Figure 2. Power-Up Reset Waveforms

f_{max} SPECIFICATIONS

f_{max} without feedback, see Figure 3

In this mode, data is presented at the input to the flip-flop and clocked through to the Q output with no feedback. Under this condition, the clock period is limited by the sum of the data setup time and the data hold time (t_{su} + t_h). However, the minimum f_{max} is determined by the minimum clock period (t_w high + t_w low).

$$\text{Thus, } f_{\text{max}} \text{ without feedback} = \frac{1}{(t_{\text{w high}} + t_{\text{w low}})} \text{ or } \frac{1}{(t_{\text{su}} + t_{\text{h}})}$$

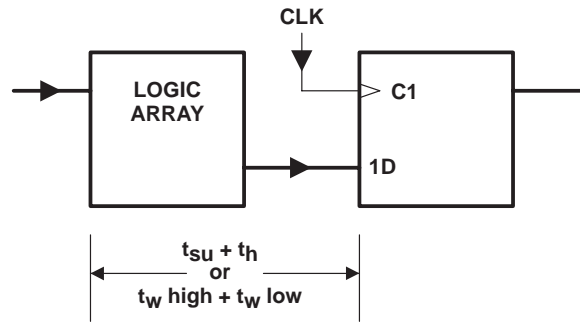

Figure 3. f_{max} Without Feedback

f_{max} with internal feedback, see Figure 4

This configuration is most popular in counters and on-chip state-machine designs. The flip-flop inputs are defined by the device inputs and flip-flop outputs. Under this condition, the period is limited by the internal delay from the flip-flop outputs through the internal feedback and logic array to the inputs of the next flip-flop.

$$\text{Thus, } f_{\text{max}} \text{ with internal feedback} = \frac{1}{(t_{\text{su}} + t_{\text{pd CLK-to-FB}})}$$

Where t_{pd} CLK-to-FB is the deduced value of the delay from CLK to the input of the logic array.

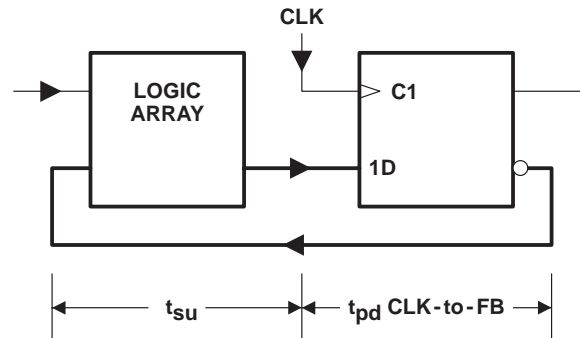

Figure 4. f_{max} With Internal Feedback

f_{max} SPECIFICATIONS

f_{max} with external feedback, see Figure 5

This configuration is a typical state-machine design with feedback signals sent off-chip. This external feedback could go back to the device inputs or to a second device in a multi-chip state machine. The slowest path defining the period is the sum of the clock-to-output time and the input setup time for the external signals ($t_{su} + t_{pd} \text{ CLK-to-Q}$).

$$\text{Thus, } f_{\text{max}} \text{ with external feedback} = \frac{1}{(t_{\text{su}} + t_{\text{pd}} \text{ CLK-to-Q})}$$

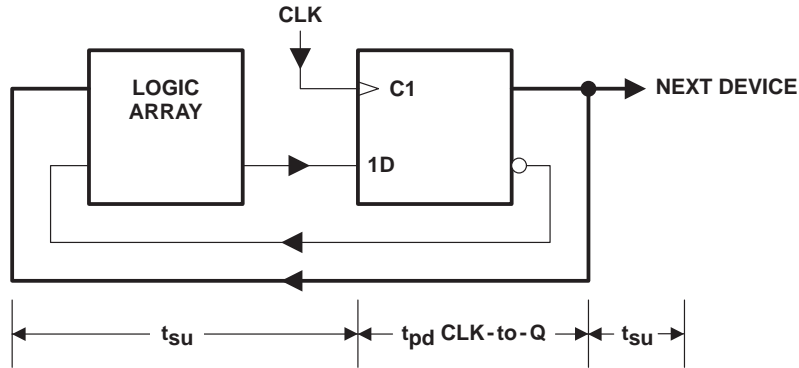
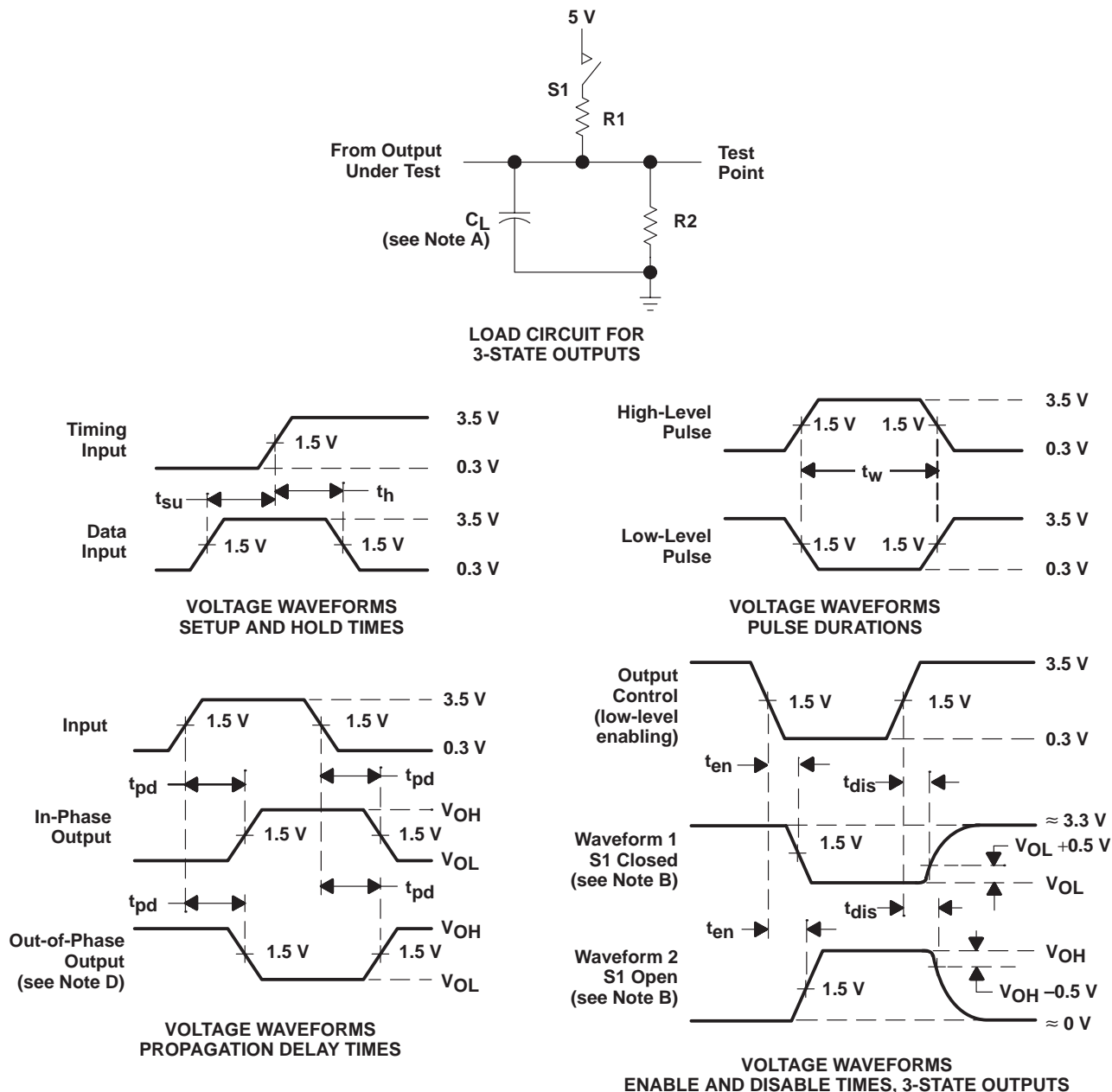

Figure 5. f_{max} With External Feedback

PARAMETER MEASUREMENT INFORMATION



- NOTES: A. C_L includes probe and jig capacitance and is 50 pF for t_{pd} and t_{en} , 5 pF for t_{dis} .
 B. Waveform 1 is for an output with internal conditions such that the output is low except when disabled by the output control. Waveform 2 is for an output with internal conditions such that the output is high except when disabled by the output control.
 C. All input pulses have the following characteristics: $PRR \leq 1$ MHz, $t_r = t_f \leq 2$ ns, duty cycle = 50%.
 D. When measuring propagation delay times of 3-state outputs, switch S1 is closed.
 E. Equivalent loads may be used for testing.

Figure 6. Load Circuit and Voltage Waveforms

TYPICAL CHARACTERISTICS

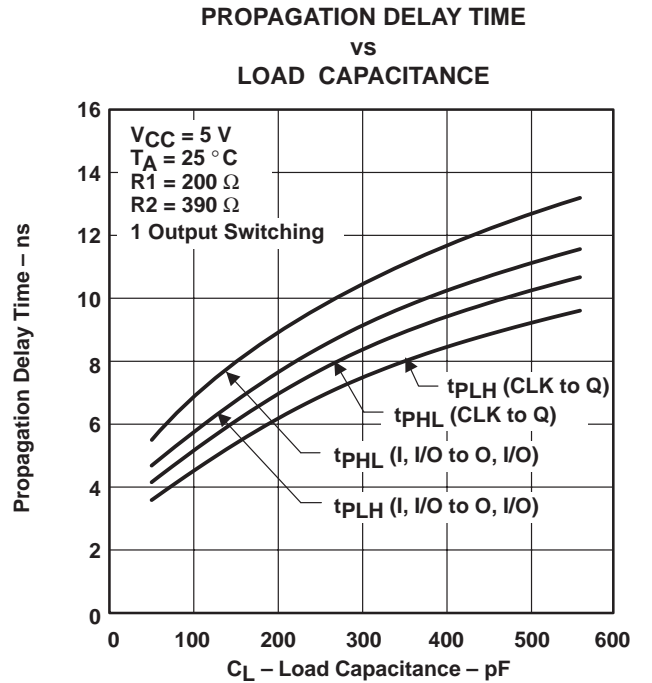
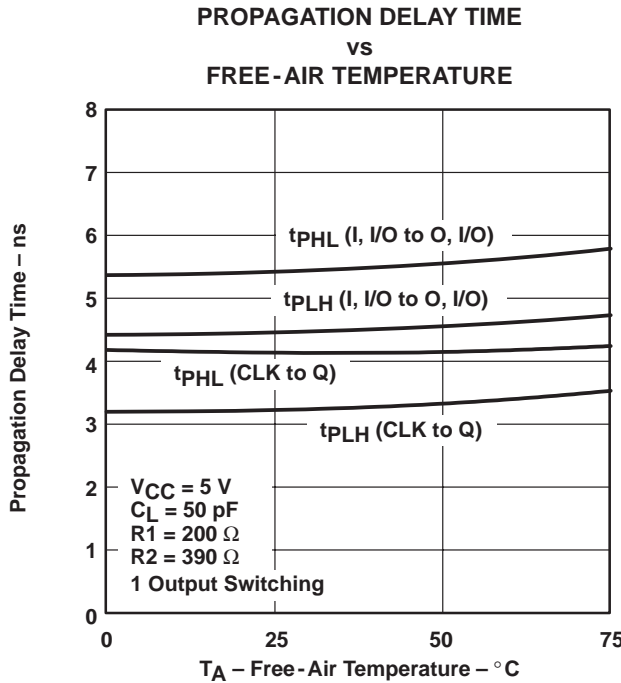
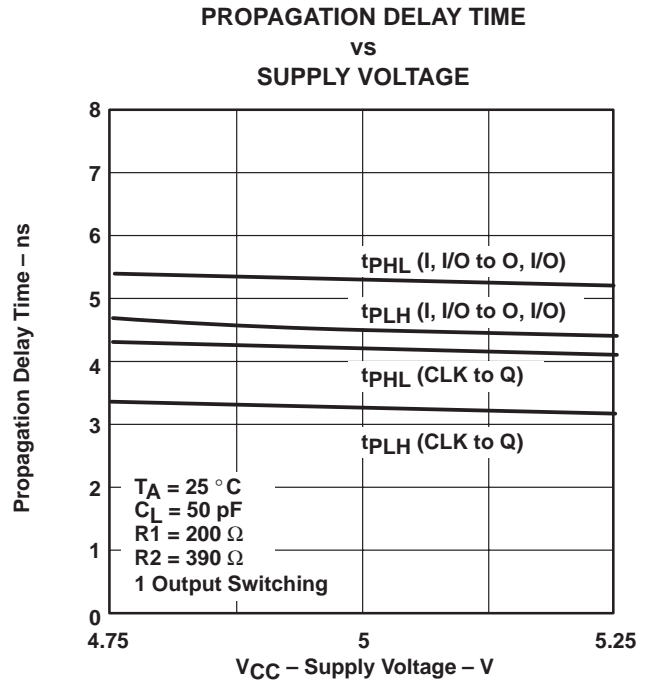
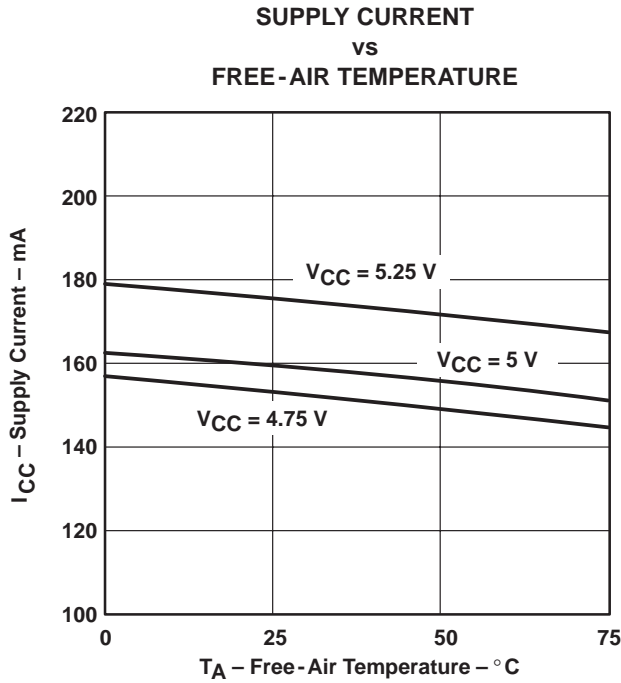

TYPICAL CHARACTERISTICS

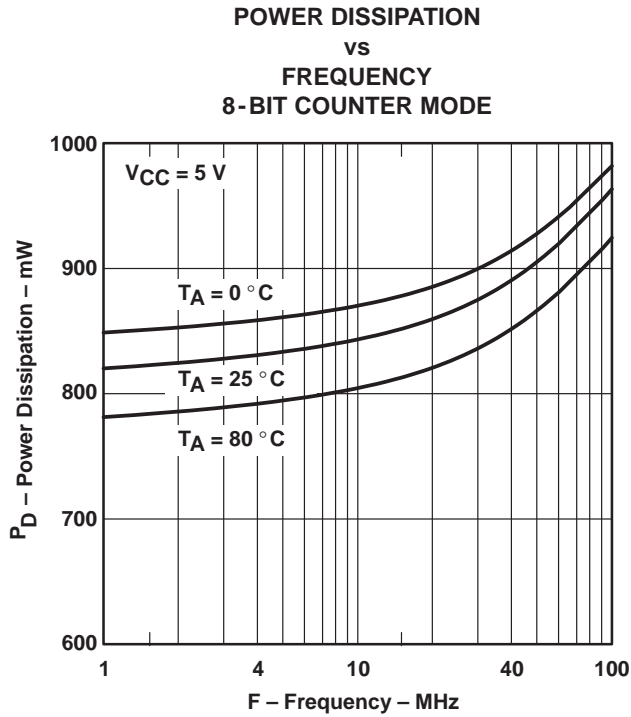

Figure 11

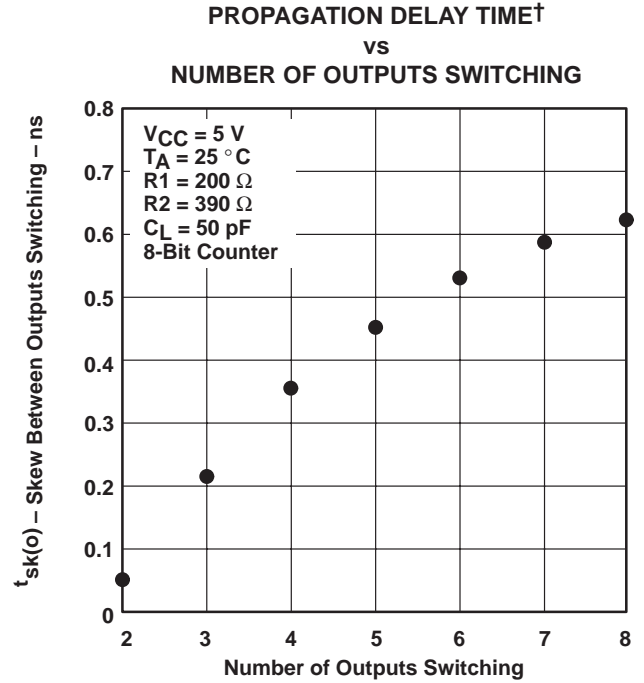

Figure 12

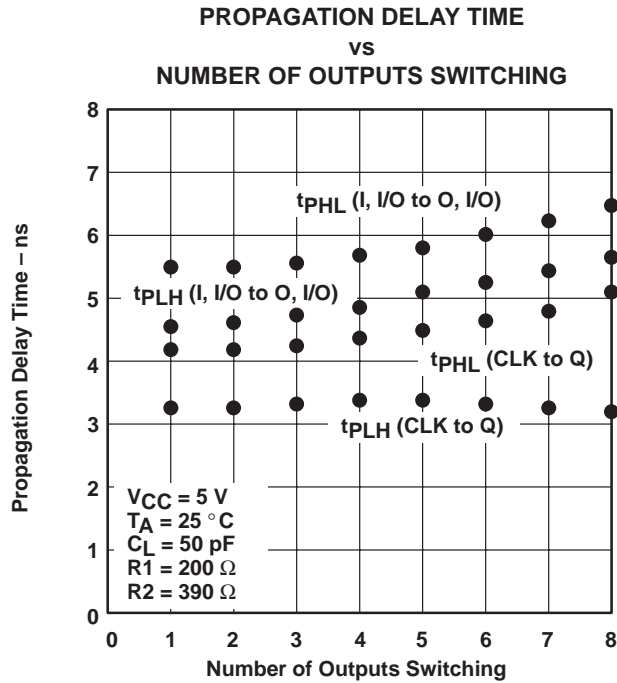

Figure 13

†Outputs switching in the same direction (tPLH compared to tPLH/tPHL to tPHL)

TI Worldwide Sales Offices

ALABAMA: Huntsville: 4960 Corporate Drive, Suite 150, Huntsville, AL 35805, (205) 837-7530.

ARIZONA: Phoenix: 8825 N. 23rd Avenue, Suite 100, Phoenix, AZ 85021, (602) 995-1007.

CALIFORNIA: Irvine: 1920 Main Street, Suite 900, Irvine, CA 92714, (714) 660-1200;

San Diego: 5625 Ruffin Road, Suite 100,

San Diego, CA 92123, (619) 278-9600;

Santa Clara: 5353 Betsy Ross Drive,

Santa Clara, CA 95054, (408) 980-9000;

Woodland Hills: 21550 Oxnard Street, Suite 700,

Woodland Hills, CA 91367, (818) 704-8100.

COLORADO: Aurora: 1400 S. Potomac Street, Suite 101, Aurora, CO 80012, (303) 368-8000.

CONNECTICUT: Wallingford: 9 Barnes Industrial Park So., Wallingford, CT 06492, (203) 269-0074.

FLORIDA: Altamonte Springs: 370 S. North Lake Boulevard, Suite 1008, Altamonte Springs, FL 32701, (407) 260-2116;

Fort Lauderdale: 2950 N.W. 62nd Street,

Suite 100, Fort Lauderdale, FL 33309,

(305) 973-8502; **Tampa:** 4803 George Road, Suite 390,

Tampa, FL 33634-6234, (813) 885-7588.

GEORGIA: Norcross: 5515 Spalding Drive,

Norcross, GA 30092-2560, (404) 662-7967.

ILLINOIS: Arlington Heights: 515 West Algonquin,

Arlington Heights, IL 60005, (708) 640-6925.

INDIANA: Carmel: 550 Congressional Drive, Suite 100,

Carmel, IN 46032, (317) 573-6400;

Fort Wayne: 103 Airport North Office Park,

Fort Wayne, IN 46825, (219) 489-4697.

KANSAS: Overland Park: 7300 Colledge Boulevard,

Lighton Plaza, Suite 150, Overland Park, KS 66210,

(913) 451-4511.

MARYLAND: Columbia: 8815 Centre Park Drive,

Suite 100, Columbia, MD 21045, (410) 964-2003.

MASSACHUSETTS: Waltham: Bay Colony Corporate

Center 950 Winter Street, Suite 2800, Waltham, MA 02154,

(617) 895-9100.

MICHIGAN: Farmington Hills: 33737 W. 12 Mile Road,

Farmington Hills, MI 48018, (313) 553-1581.

MINNESOTA: Eden Prairie: 11000 W. 78th Street,

Suite 100, Eden Prairie, MN 55344, (612) 828-9300.

MISSOURI: St. Louis: 12412 Powerscourt Drive,

Suite 125, St. Louis, MO 63131, (314) 821-8400.

NEW JERSEY: Iselin: Metropolitan Corporate Plaza, 485

Bldg E. U.S. 1 South, Iselin, NJ 08830, (908) 750-1050.

NEW MEXICO: Albuquerque: 2709 J. Pan American

Freeway, N.E., Albuquerque, NM 87101, (505) 345-2555.

NEW YORK: East Syracuse: 6365 Collamer Drive,

East Syracuse, NY 13057, (315) 463-9291;

Fishkill: 300 Westage Business Center, Suite 140,

Fishkill, NY 12524, (914) 897-2900;

Melville: 48 South Service Road, Suite 100, Melville, NY

11747, (516) 454-6601;

Pittsford: 2851 Clover Street, Pittsford, NY 14534,

(716) 385-6770.

NORTH CAROLINA: Charlotte: 8 Woodlawn Green,

Suite 100, Charlotte, NC 28217, (704) 527-0930;

Raleigh: 2809 Highwoods Boulevard, Suite 100,

Raleigh, NC 27625, (919) 876-2725.

OHIO: Beachwood: 23775 Commerce Park Road,

Beachwood, OH 44122-5875, (216) 765-7258;

Beavercreek: 4200 Colonel Glenn Highway, Suite 600,

Beavercreek, OH 45431, (513) 427-6200.

OREGON: Beaverton: 6700 S.W. 105th Street,

Suite 110, Beaverton, OR 97005, (503) 643-6758.

PENNSYLVANIA: Blue Bell: 670 Sentry Parkway,

Suite 200, Blue Bell, PA 19422, (215) 825-9500.

PUERTO RICO: Hato Rey: 615 Mercantile Plaza Building,

Suite 505, Hato Rey, PR 00919, (809) 753-8700.

TEXAS: Austin: 12501 Research Boulevard,

Austin, TX 78759, (512) 250-6769;

Dallas: 7839 Churchill Way, Dallas, TX 75251,

(214) 917-1264;

Houston: 9301 Southwest Freeway, Commerce Park, Suite

360, Houston, TX 77074, (713) 778-6592;

Midland: FM 1788 & I-20, Midland, TX 79711-0448,

(915) 561-7137.

UTAH: Salt Lake City: 2180 South 1300 East, Suite 335, Salt Lake City, UT 54106, (801) 466-8972.

WISCONSIN: Waukesha: 20825 Swenson Drive,

Suite 900, Waukesha WI 53186, (414) 798-1001.

CANADA: Nepean: 301 Moodie Drive, Suite 102, Mallom

Center, Nepean, Ontario, Canada K2H 9C4,

(613) 726-1970;

Richmond Hill: 280 Centre Street East, Richmond Hill,

Ontario, Canada L4C 1B1, (416) 884-9181;

St. Laurent: 9460 Trans Canada Highway, St. Laurent,

Quebec, Canada H4S 1R7, (514) 335-8392.

AUSTRALIA (& NEW ZEALAND): Texas Instruments

Australia Ltd., 6-10 Talavera Road, North Ryde (Sydney),

New South Wales, Australia 2113, 2-878-9000; 14th Floor,

380 Street, Kilda Road, Melbourne, Victoria, Australia 3004,

3-696-1211; 171 Philip Highway, Elizabeth, South Australia

5112, 8 255-2066.

BELGIUM: Texas Instruments Belgium S.A./N.V.,

Avenue Jules Bordetlaan 11, 1140 Brussels, Belgium,

(02) 242 30 80.

BRAZIL: Texas Instruments Electronicos do Brasil Ltda.,

Av. Eng. Luiz Carlos Berrini 1461-11o andar, 04571,

Sao Paulo, SP, Brazil, 11-535-5133.

DENMARK: Texas Instruments A/S, Borupvang 2D,

2750 Ballerup, Denmark, (44) 68 74 00.

FINLAND: Texas Instruments OY, Ahertajantie 3,

P.O. Box 86, 02321 Espoo, Finland, (0) 802 6517.

FRANCE: Texas Instruments France, 8-10 Avenue

Morane-Saulnier, B.P. 67, 78141 Velizy Villacoublay Cedex,

France, (1) 30 70 1003.

GERMANY: Texas Instruments Deutschland GmbH.,

Haggertystrasse 1, 8050 Freising, (08161) 80-0;

Kurfurstendamm 195-196, 1000 Berlin 15, (030) 8 82 73 65;

Dusseldorfer Strasse 40, 6236 Eschborn 1, (06196) 80 70;

Kirchhorster Strasse 2, 3000 Hannover 51, (0511) 64 68-0;

Maybachstrasse 11, 7302 Ostfildern 2 (Nellingen),

(0711) 3403257; Gildehofcenter, Hollestrasses 3, 4300

Essen 1, (0201) 24 25-0.

HOLLAND: Texas Instruments Holland B.V., Hoogehilweg

19, Postbus 12995, 1100 AZ Amsterdam-Zuidooit, Holland,

(020) 5602911.

HONG KONG: Texas Instruments Hong Kong Ltd., 8th

Floor, World Shipping Center, 7 Canton Road, Kowloon,

Hong Kong, 737-0338.

HUNGARY: Texas Instruments Representation, Budaorsi

ut.42, 1112 Budapest, Hungary, (1) 1 66 66 17.

IRELAND: Texas Instruments Ireland Ltd., 7/8 Harcourt

Street, Dublin 2, Ireland, (01) 755233.

ITALY: Texas Instruments Italia S.p.a., Centro Direzionale

Colleoni, Palazzo Perseo-Via Paracelso 12, 20041 Agrate

Brianza (Mi), Italy, (039) 63221; Via Castello della Magliana,

38, 00148 Roma, Italy (06) 6572651; Via Amendola, 17,

40100 Bologna, Italy (051) 554004.

JAPAN: Texas Instruments Japan Ltd., Aoyama Fuji

Building 3-6-12 Kita-Aoyama Minato-ku, Tokyo, Japan 107,

03-498-2111; MS Shibaura Building 9F, 4-13-23 Shibaura,

Minato-ku, Tokyo, Japan 108, 03-769-8700; Nishio-wei

Building 5F, 2-5-8 Imabashi, Chuou-ku, Osaka, Japan 541,

06-204-1881; Dai-ni Toyota Building Nishi-kan 7F, 4-10-27

Meieki, Nakamura-ku, Nagoya, Japan 450, 052-583-8691;

Kanazawa Oyama-cho Daiichi Seimei Building 6F, 3-10

Oyama-cho, Kanazawa, Ishikawa, Japan 920,

0762-23-5471; Matsumoto Showa Building 6F, 1-2-11

Fukashi, Matsumoto, Nagano, Japan 390, 0263-33-1060;

Daiichi Olympic Tachikawa Building 6F, 1-25-12,

Akebono-cho, Tachikawa, Tokyo, Japan 190,

0425-27-6760; Yokohama Business Park East Tower 10F,

134 Goudo-cho Hodogaya-ku, Yokohama-shi, Kanagawa,

Japan 240, 045-338-1220; Nihon Seimei Kyoto Yasaka

Building 5F, 843-2, Higashi Shiohohji-cho, Higashi-iru,

Nishinotoh-in, Shiohohji-dori, Shimogyo-ku, Kyoto, Japan

600, 075-341-7713; Sumitomo Seimei Kumagaya Building

8F, 2-44 Yavoi, Kumagaya, Saitama, Japan 360,

0485-22-2440; 2597-1, Aza Harudai, Oaza Yasaka, Kitsuki,

Oita, Japan 873, 09786-3-3211.

KOREA: Texas Instruments Korea Ltd., 28th Floor, Trade

Tower, 159, Samsung-Dong, Kangnam-ku Seoul, Korea, 2

551-2800.

MALAYSIA: Texas Instruments Malaysia, Sdn. Bhd., Asia Pacific, Lot 36.1 #Box 93, Menara Maybank, 100 Jalan Tun Perak, 50050 Kuala Lumpur, Malaysia, 2306001.

MEXICO: Texas Instruments de Mexico S.A., de C.V., Alfonso Reyes 115, Col. Hipodromo Condesa, Mexico, D.F., Mexico 06170, 5-515-6081.

NORWAY: Texas Instruments Norge A/S, P.B. 106, Refstad (Sinsenveien 53), 0513 Oslo 5, Norway, (02) 155 090.

PEOPLE'S REPUBLIC OF CHINA: Texas Instruments China Inc., Beijing Representative Office, 7-05 CITIC Building, 19 Jianguomenwai Dajie, Beijing, China, 500-2255, Ext. 7500.

PHILIPPINES: Texas Instruments Asia Ltd., Philippines Branch, 14th Floor, Ba-Lepanto Building, Paseo de Roxas, Makati, Metro Manila, Philippines, 2-8176031.

PORTUGAL: Texas Instruments Equipamento Electronico (Portugal) Ltda., Ing. Frederico Ulricho, 2650 Moreira Da Maia, 4470 Maia, Portugal (2) 948 1003.

SINGAPORE (& INDIA, INDONESIA, MALAYSIA, THAILAND): Texas Instruments Singapore (PTE) Ltd., Asia Pacific, 101 Thomson Road, #23-01, United Square, Singapore 1130, 3508100.

SPAIN: Texas Instruments Espana S.A., c/Gobelos 43, Urbanizacion, La Florida, 28023, Madrid, Spain, (1) 372 8051; c/Diputacion, 279-3-5, 08007 Barcelona, Spain, (3) 317 91 80.

SWEDEN: Texas Instruments International Trade Corporation (Sverigefilialen), Isafjordsgaton, Box 30, S-164 93 Kista, Sweden, (08) 752 58 00.

SWITZERLAND: Texas Instruments Switzerland AG, Riedstrasse 6, C8953 Dietikon, Switzerland, (01) 744 2811.

TAIWAN: Texas Instruments Taiwan Limited, Taipei Branch, 10th Floor Bank Tower, 205 Tung Hwa N. Road, Taipei, Taiwan, 10592 Republic of China, 2-7139311.

TURKEY: Texas Instruments, DSEG MidEast Regional Marketing Office, Karum Center, Suite 442, Iran Caddesi 21, 06680 Kavaklidere, Ankara, Turkey, 4-468-0155.

UNITED KINGDOM: Texas Instruments Ltd., Manton Lane, Bedford, England, MK41 7PA, (0234) 270 111.

TI Authorized North American Distributors

Alliance Electronics, Inc. (military product only)

Almac/Arrow

Anthem Electronics

Arrow/Schweber

Future Electronics (Canada)

GRS Electronics Co., Inc. *

Hall-Mark Electronics

Marshall Industries

Newark Electronics *

Wyle Laboratories

Zeus Components

Rochester Electronics, Inc. (obsolete product only)

*Not authorized for TI military products



TI North American Sales Offices

ALABAMA: Huntsville: (205) 837-7530
ARIZONA: Phoenix: (602) 995-1007
CALIFORNIA: Irvine: (714) 660-1200
San Diego: (619) 278-9600
Santa Clara: (408) 980-9000
Woodland Hills: (818) 704-8100
COLORADO: Aurora: (303) 368-8000
CONNECTICUT: Wallingford: (203) 269-0074
FLORIDA: Altamonte Springs: (407) 260-2116
Fort Lauderdale: (305) 973-8502
Tampa: (813) 885-7588
GEORGIA: Norcross: (404) 662-7967
ILLINOIS: Arlington Heights: (708) 640-3000
INDIANA: Carmel: (317) 573-6400
Fort Wayne: (219) 489-4697
KANSAS: Overland Park: (913) 451-4511
MARYLAND: Columbia: (410) 964-2003
MASSACHUSETTS: Waltham: (617) 895-9100
MICHIGAN: Farmington Hills: (313) 553-1581
MINNESOTA: Eden Prairie: (612) 828-9300
MISSOURI: St. Louis: (314) 821-8400
NEW JERSEY: Iselin: (908) 750-1050
NEW MEXICO: Albuquerque: (505) 345-2555
NEW YORK: East Syracuse: (315) 463-9291
Fishkill: (914) 897-2900
Melville: (516) 454-6600
Pittsford: (716) 385-6770
NORTH CAROLINA: Charlotte: (704) 527-0930
Raleigh: (919) 876-2725
OHIO: Beachwood: (216) 765-7258
Beavercreek: (513) 427-6200
OREGON: Beaverton: (503) 643-6758
PENNSYLVANIA: Blue Bell: (215) 825-9500
PUERTO RICO: Hato Rey: (809) 753-8700
TEXAS: Austin: (512) 250-6769
Dallas: (214) 917-1264
Houston: (713) 778-6592
Midland: (915) 561-7137
UTAH: Salt Lake City: (801) 466-8972
WISCONSIN: Waukesha: (414) 798-1001
CANADA: Nepean: (613) 726-1970
Richmond Hill: (416) 884-9181
St. Laurent: (514) 335-8392

TI Regional Technology Centers

CALIFORNIA: Irvine: (714) 660-8140
Santa Clara: (408) 748-2222
GEORGIA: Norcross: (404) 662-7945
ILLINOIS: Arlington Heights: (708) 640-2909
INDIANA: Indianapolis: (317) 573-6400
MASSACHUSETTS: Waltham: (617) 895-9196
MEXICO: Mexico City: 491-70834
MINNESOTA: Minneapolis: (612) 828-9300
TEXAS: Dallas: (214) 917-3881
CANADA: Nepean: (613) 726-1970

Customer Response Center

TOLL FREE: (800) 336-5236
OUTSIDE USA: (214) 995-6611
(8:00 a.m. – 5:00 p.m. CST)

TI Authorized North American Distributors

Alliance Electronics, Inc. (military product only)
Almac/Arrow
Anthem Electronics
Arrow/Schweber
Future Electronics (Canada)
GRS Electronics Co., Inc.
Hall-Mark Electronics
Marshall Industries
Newark Electronics
Rochester Electronics, Inc.
(obsolete product only) (508) 462-9332
Wyle Laboratories
Zeus Components

TI Distributors

ALABAMA: Arrow/Schweber (205) 837-6955; Hall-Mark (205) 837-8700; Marshall (205) 881-9235.
ARIZONA: Anthem (602) 966-6600; Arrow/Schweber (602) 437-0750; Hall-Mark (602) 431-0030; Marshall (602) 496-0290; Wyle (602) 437-2088.
CALIFORNIA: Los Angeles/Orange County: Anthem (818) 775-1333, (714) 768-4444; Arrow/Schweber (818) 380-9686, (714) 838-5422; Hall-Mark (818) 773-4500, (714) 727-6000; Marshall (818) 878-7000, (714) 458-5301; Wyle (818) 880-9000, (714) 863-9953; Zeus (714) 921-9000, (818) 889-3838;
Sacramento: Anthem (916) 624-9744; Hall-Mark (916) 624-9781; Marshall (916) 635-9700; Wyle (916) 638-5282;
San Diego: Anthem (619) 453-9005; Arrow/Schweber (619) 565-4800; Hall-Mark (619) 268-1201; Marshall (619) 578-9600; Wyle (619) 565-9171; Zeus (619) 277-9681.
San Francisco Bay Area: Anthem (408) 453-1200; Arrow/Schweber (408) 441-9700, (510) 490-9477; Hall-Mark (408) 432-4000; Marshall (408) 942-4600; Wyle (408) 727-2500; Zeus (408) 629-4789.
COLORADO: Anthem (303) 790-4500; Arrow/Schweber (303) 799-0258; Hall-Mark (303) 790-1662; Marshall (303) 451-8383; Wyle (303) 457-9953.
CONNECTICUT: Anthem (203) 575-1575; Arrow/Schweber (203) 265-7741; Hall-Mark (203) 271-2844; Marshall (203) 265-3822.
FLORIDA: Fort Lauderdale: Arrow/Schweber (305) 429-8200; Hall-Mark (305) 971-9280; Marshall (305) 977-4880.
Orlando: Arrow/Schweber (407) 333-9300; Hall-Mark (407) 830-5855; Marshall (407) 767-8585; Zeus (407) 788-9100.
Tampa: Hall-Mark (813) 541-7440; Marshall (813) 573-1399.
GEORGIA: Arrow/Schweber (404) 497-1300; Hall-Mark (404) 623-4400; Marshall (404) 923-5750.
ILLINOIS: Anthem (708) 884-0200; Arrow/Schweber (708) 250-0500; Hall-Mark (312) 860-3800; Marshall (708) 490-0155; Newark (312) 784-5100.
INDIANA: Arrow/Schweber (317) 299-2071; Hall-Mark (317) 872-8875; Marshall (317) 297-0483.
IOWA: Arrow/Schweber (319) 395-7230.
KANSAS: Arrow/Schweber (913) 541-9542; Hall-Mark (913) 888-4747; Marshall (913) 492-3121.
MARYLAND: Anthem (301) 995-6640; Arrow/Schweber (301) 596-7800; Hall-Mark (301) 988-9800; Marshall (301) 622-1118; Zeus (301) 997-1118.
MASSACHUSETTS: Anthem (508) 657-5170; Arrow/Schweber (508) 658-0900; Hall-Mark (508) 667-0902; Marshall (508) 658-0810; Wyle (617) 272-7300; Zeus (617) 246-8200.



MICHIGAN: Detroit: Arrow/Schweber (313) 462-2290; Hall-Mark (313) 416-5800; Marshall (313) 525-5850; Newark (313) 967-0600.
MINNESOTA: Anthem (612) 944-5454; Arrow/Schweber (612) 941-5280; Hall-Mark (612) 881-2600; Marshall (612) 559-2211.
MISSOURI: Arrow/Schweber (314) 567-6888; Hall-Mark (314) 291-5350; Marshall (314) 291-4650.
NEW JERSEY: Anthem (201) 227-7960; Arrow/Schweber (201) 227-7880, (609) 596-8000; Hall-Mark (201) 515-3000, (609) 235-1900; Marshall (201) 882-0320, (609) 234-9100.
NEW MEXICO: Alliance (505) 292-3360.
NEW YORK: Long Island: Anthem (516) 864-6600; Arrow/Schweber (516) 231-1000; Hall-Mark (516) 737-0600; Marshall (516) 273-2424; Zeus (914) 937-7400.
Rochester: Arrow/Schweber (716) 427-0300; Hall-Mark (716) 425-3300; Marshall (716) 235-7620.
Syracuse: Marshall (607) 785-2345.
NORTH CAROLINA: Arrow/Schweber (919) 876-3132; Hall-Mark (919) 872-0712; Marshall (919) 878-9882.
OHIO: Cleveland: Arrow/Schweber (216) 248-3990; Hall-Mark (216) 349-4632; Marshall (216) 248-1788.
Columbus: Hall-Mark (614) 888-3313.
Dayton: Arrow/Schweber (513) 435-5563; Marshall (513) 898-4480; Zeus (513) 293-6162.
OKLAHOMA: Arrow/Schweber (918) 252-7537; Hall-Mark (918) 254-6110.
OREGON: Almac/Arrow (503) 629-8090; Anthem (503) 643-1114; Marshall (503) 644-5050; Wyle (503) 643-7900.
PENNSYLVANIA: Anthem (215) 443-5150; Arrow/Schweber (215) 928-1800; GRS (215) 922-7037; (609) 964-8560; Marshall (412) 788-0441.
TEXAS: Austin: Arrow/Schweber (512) 835-4180; Hall-Mark (512) 258-8848; Marshall (512) 837-1991; Wyle (512) 345-8853;
Dallas: Anthem (214) 238-7100; Arrow/Schweber (214) 380-6464; Hall-Mark (214) 553-4300; Marshall (214) 233-5200; Wyle (214) 235-9953; Zeus (214) 783-7010;
Houston: Arrow/Schweber (713) 530-4700; Hall-Mark (713) 781-6100; Marshall (713) 467-1666; Wyle (713) 879-9953.
UTAH: Anthem (801) 973-8555; Arrow/Schweber (801) 973-6913; Marshall (801) 973-2288; Wyle (801) 974-9953.
WASHINGTON: Almac/Arrow (206) 643-9992; Anthem (206) 483-1700; Marshall (206) 486-5747; Wyle (206) 881-1150.
WISCONSIN: Arrow/Schweber (414) 792-0150; Hall-Mark (414) 797-7844; Marshall (414) 797-8400.
CANADA: Calgary: Future (403) 235-5325;
Edmonton: Future (403) 438-2858;
Montreal: Arrow/Schweber (514) 421-7411; Future (514) 694-7710; Marshall (514) 694-8142
Ottawa: Arrow/Schweber (613) 226-6903; Future (613) 820-8313.
Quebec: Future (418) 897-6666.
Toronto: Arrow/Schweber (416) 670-7769; Future (416) 612-9200; Marshall (416) 458-8046.
Vancouver: Arrow/Schweber (604) 421-2333; Future (604) 294-1166.

TI Die Processors

Chip Supply (407) 298-7100
Elmo Semiconductor (818) 768-7400
Minco Technology Labs (512) 834-2022

D0892

PACKAGING INFORMATION

Orderable Device	Status ⁽¹⁾	Package Type	Package Drawing	Pins	Package Qty	Eco Plan ⁽²⁾	Lead/Ball Finish	MSL Peak Temp ⁽³⁾
TIBPAL20L8-10CFN	OBSOLETE	PLCC	FN	28		TBD	Call TI	Call TI
TIBPAL20L8-10CNT	OBSOLETE	PDIP	NT	24		TBD	Call TI	Call TI
TIBPAL20R4-10CFN	OBSOLETE	PLCC	FN	28		TBD	Call TI	Call TI
TIBPAL20R4-10CNT	OBSOLETE	PDIP	NT	24		TBD	Call TI	Call TI
TIBPAL20R6-10CFN	ACTIVE	PLCC	FN	28	37	TBD	CU SNPB	Level-1-220C-UNLIM
TIBPAL20R6-10CNT	ACTIVE	PDIP	NT	24	15	Pb-Free (RoHS)	CU NIPDAU	N / A for Pkg Type
TIBPAL20R8-10CFN	ACTIVE	PLCC	FN	28	37	TBD	CU SNPB	Level-1-220C-UNLIM
TIBPAL20R8-10CNT	ACTIVE	PDIP	NT	24	15	Pb-Free (RoHS)	CU NIPDAU	N / A for Pkg Type

⁽¹⁾ The marketing status values are defined as follows:

ACTIVE: Product device recommended for new designs.

LIFEBUY: TI has announced that the device will be discontinued, and a lifetime-buy period is in effect.

NRND: Not recommended for new designs. Device is in production to support existing customers, but TI does not recommend using this part in a new design.

PREVIEW: Device has been announced but is not in production. Samples may or may not be available.

OBSOLETE: TI has discontinued the production of the device.

⁽²⁾ Eco Plan - The planned eco-friendly classification: Pb-Free (RoHS), Pb-Free (RoHS Exempt), or Green (RoHS & no Sb/Br) - please check <http://www.ti.com/productcontent> for the latest availability information and additional product content details.

TBD: The Pb-Free/Green conversion plan has not been defined.

Pb-Free (RoHS): TI's terms "Lead-Free" or "Pb-Free" mean semiconductor products that are compatible with the current RoHS requirements for all 6 substances, including the requirement that lead not exceed 0.1% by weight in homogeneous materials. Where designed to be soldered at high temperatures, TI Pb-Free products are suitable for use in specified lead-free processes.

Pb-Free (RoHS Exempt): This component has a RoHS exemption for either 1) lead-based flip-chip solder bumps used between the die and package, or 2) lead-based die adhesive used between the die and leadframe. The component is otherwise considered Pb-Free (RoHS compatible) as defined above.

Green (RoHS & no Sb/Br): TI defines "Green" to mean Pb-Free (RoHS compatible), and free of Bromine (Br) and Antimony (Sb) based flame retardants (Br or Sb do not exceed 0.1% by weight in homogeneous material)

⁽³⁾ MSL, Peak Temp. -- The Moisture Sensitivity Level rating according to the JEDEC industry standard classifications, and peak solder temperature.

Important Information and Disclaimer:The information provided on this page represents TI's knowledge and belief as of the date that it is provided. TI bases its knowledge and belief on information provided by third parties, and makes no representation or warranty as to the accuracy of such information. Efforts are underway to better integrate information from third parties. TI has taken and continues to take reasonable steps to provide representative and accurate information but may not have conducted destructive testing or chemical analysis on incoming materials and chemicals. TI and TI suppliers consider certain information to be proprietary, and thus CAS numbers and other limited information may not be available for release.

In no event shall TI's liability arising out of such information exceed the total purchase price of the TI part(s) at issue in this document sold by TI to Customer on an annual basis.

NT (R-PDIP-T**)

PLASTIC DUAL-IN-LINE PACKAGE

24 PINS SHOWN

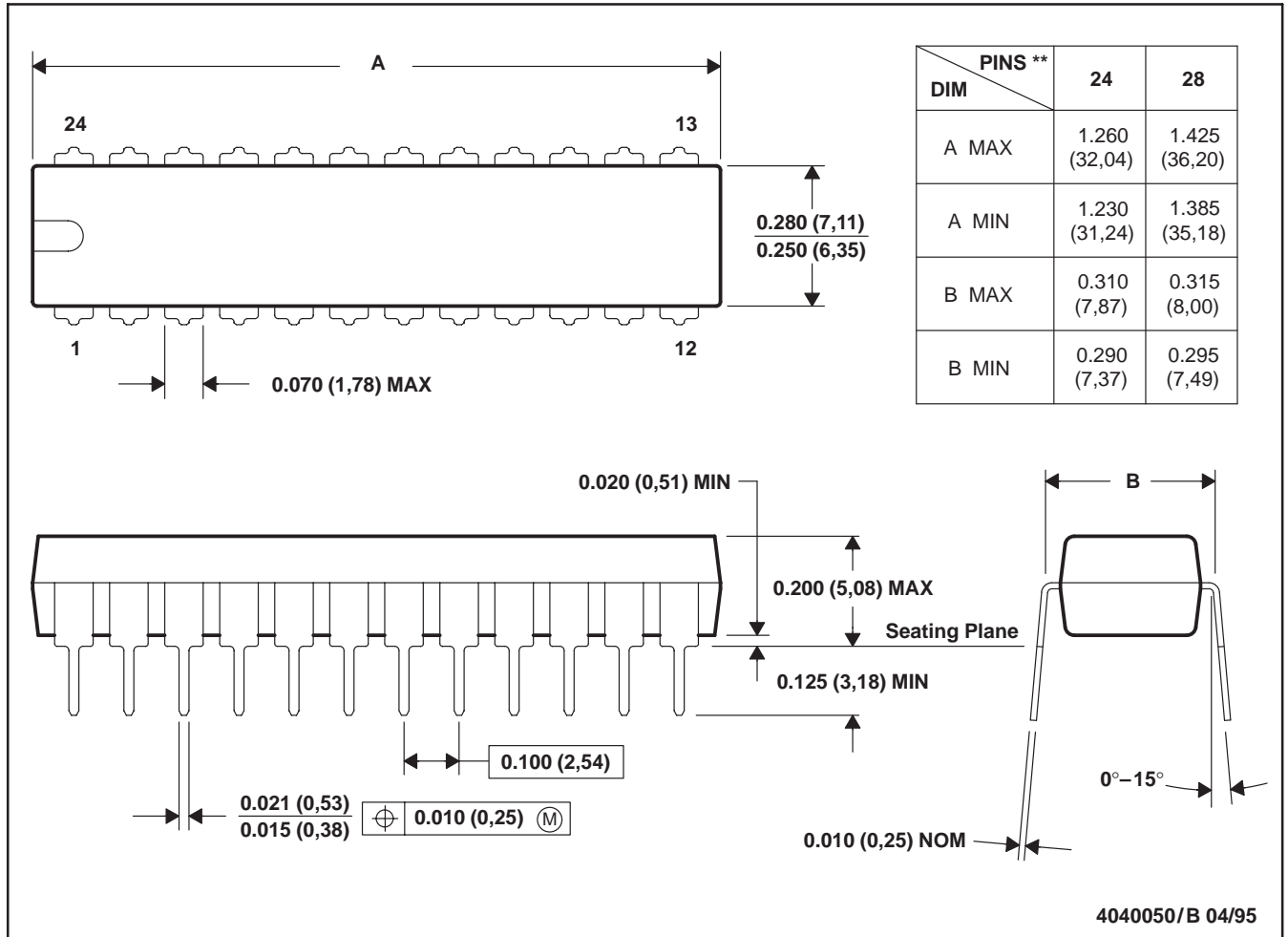

NOTES: A. All linear dimensions are in inches (millimeters).
 B. This drawing is subject to change without notice.

FN (S-PQCC-J**)

PLASTIC J-LEADED CHIP CARRIER

20 PIN SHOWN

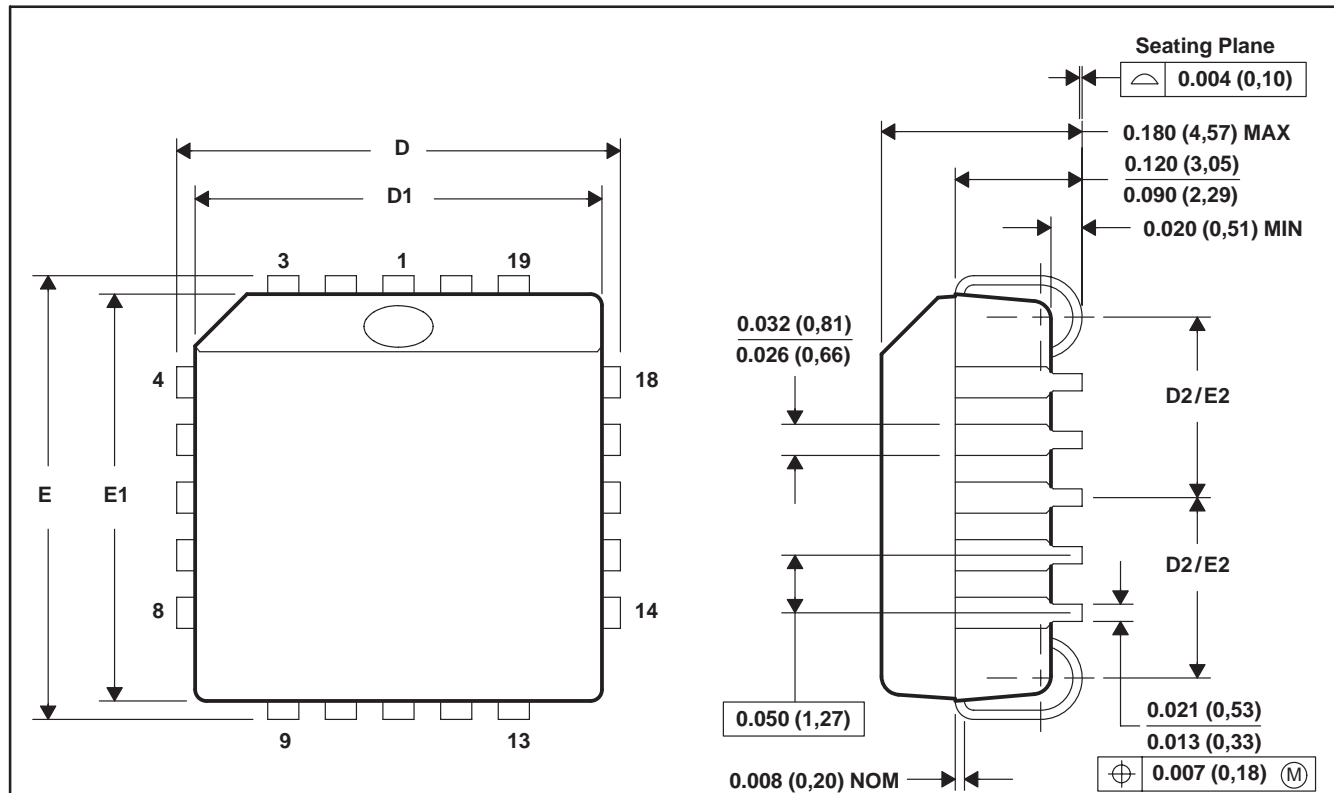

NO. OF PINS **	D/E		D1/E1		D2/E2	
	MIN	MAX	MIN	MAX	MIN	MAX
20	0.385 (9,78)	0.395 (10,03)	0.350 (8,89)	0.356 (9,04)	0.141 (3,58)	0.169 (4,29)
28	0.485 (12,32)	0.495 (12,57)	0.450 (11,43)	0.456 (11,58)	0.191 (4,85)	0.219 (5,56)
44	0.685 (17,40)	0.695 (17,65)	0.650 (16,51)	0.656 (16,66)	0.291 (7,39)	0.319 (8,10)
52	0.785 (19,94)	0.795 (20,19)	0.750 (19,05)	0.756 (19,20)	0.341 (8,66)	0.369 (9,37)
68	0.985 (25,02)	0.995 (25,27)	0.950 (24,13)	0.958 (24,33)	0.441 (11,20)	0.469 (11,91)
84	1.185 (30,10)	1.195 (30,35)	1.150 (29,21)	1.158 (29,41)	0.541 (13,74)	0.569 (14,45)

4040005/B 03/95

- NOTES: A. All linear dimensions are in inches (millimeters).
 B. This drawing is subject to change without notice.
 C. Falls within JEDEC MS-018

IMPORTANT NOTICE

Texas Instruments Incorporated and its subsidiaries (TI) reserve the right to make corrections, modifications, enhancements, improvements, and other changes to its products and services at any time and to discontinue any product or service without notice. Customers should obtain the latest relevant information before placing orders and should verify that such information is current and complete. All products are sold subject to TI's terms and conditions of sale supplied at the time of order acknowledgment.

TI warrants performance of its hardware products to the specifications applicable at the time of sale in accordance with TI's standard warranty. Testing and other quality control techniques are used to the extent TI deems necessary to support this warranty. Except where mandated by government requirements, testing of all parameters of each product is not necessarily performed.

TI assumes no liability for applications assistance or customer product design. Customers are responsible for their products and applications using TI components. To minimize the risks associated with customer products and applications, customers should provide adequate design and operating safeguards.

TI does not warrant or represent that any license, either express or implied, is granted under any TI patent right, copyright, mask work right, or other TI intellectual property right relating to any combination, machine, or process in which TI products or services are used. Information published by TI regarding third-party products or services does not constitute a license from TI to use such products or services or a warranty or endorsement thereof. Use of such information may require a license from a third party under the patents or other intellectual property of the third party, or a license from TI under the patents or other intellectual property of TI.

Reproduction of TI information in TI data books or data sheets is permissible only if reproduction is without alteration and is accompanied by all associated warranties, conditions, limitations, and notices. Reproduction of this information with alteration is an unfair and deceptive business practice. TI is not responsible or liable for such altered documentation. Information of third parties may be subject to additional restrictions.

Resale of TI products or services with statements different from or beyond the parameters stated by TI for that product or service voids all express and any implied warranties for the associated TI product or service and is an unfair and deceptive business practice. TI is not responsible or liable for any such statements.

TI products are not authorized for use in safety-critical applications (such as life support) where a failure of the TI product would reasonably be expected to cause severe personal injury or death, unless officers of the parties have executed an agreement specifically governing such use. Buyers represent that they have all necessary expertise in the safety and regulatory ramifications of their applications, and acknowledge and agree that they are solely responsible for all legal, regulatory and safety-related requirements concerning their products and any use of TI products in such safety-critical applications, notwithstanding any applications-related information or support that may be provided by TI. Further, Buyers must fully indemnify TI and its representatives against any damages arising out of the use of TI products in such safety-critical applications.

TI products are neither designed nor intended for use in military/aerospace applications or environments unless the TI products are specifically designated by TI as military-grade or "enhanced plastic." Only products designated by TI as military-grade meet military specifications. Buyers acknowledge and agree that any such use of TI products which TI has not designated as military-grade is solely at the Buyer's risk, and that they are solely responsible for compliance with all legal and regulatory requirements in connection with such use.

TI products are neither designed nor intended for use in automotive applications or environments unless the specific TI products are designated by TI as compliant with ISO/TS 16949 requirements. Buyers acknowledge and agree that, if they use any non-designated products in automotive applications, TI will not be responsible for any failure to meet such requirements.

Following are URLs where you can obtain information on other Texas Instruments products and application solutions:

Products

Amplifiers	amplifier.ti.com
Data Converters	dataconverter.ti.com
DSP	dsp.ti.com
Clocks and Timers	www.ti.com/clocks
Interface	interface.ti.com
Logic	logic.ti.com
Power Mgmt	power.ti.com
Microcontrollers	microcontroller.ti.com
RFID	www.ti-rfid.com
RF/IF and ZigBee® Solutions	www.ti.com/lprf

Applications

Audio	www.ti.com/audio
Automotive	www.ti.com/automotive
Broadband	www.ti.com/broadband
Digital Control	www.ti.com/digitalcontrol
Medical	www.ti.com/medical
Military	www.ti.com/military
Optical Networking	www.ti.com/opticalnetwork
Security	www.ti.com/security
Telephony	www.ti.com/telephony
Video & Imaging	www.ti.com/video
Wireless	www.ti.com/wireless

Mailing Address: Texas Instruments, Post Office Box 655303, Dallas, Texas 75265
Copyright © 2008, Texas Instruments Incorporated

Looking for pricing, stock, or lifecycle information?

Click below to explore more details on WIN SOURCE:

 [View TIBPAL20R6-10CNT on WIN SOURCE](#)

 [Texas Instruments](#) Information

Optimize Your Supply Chain with WIN SOURCE Solutions

-  Global Sourcing Solution
-  Obsolete Management
-  Cost Control Management
-  Shortage Management
-  Alternative Solution
-  Excess Inventory Management