



**THE DATASHEET OF
SY100S314FC**



FEATURES

- Max. propagation delay of 900ps
- Differential outputs
- IEE min. of -60mA
- Extended supply voltage option:
VEE = -4.2V to -5.5V
- Voltage and temperature compensation for improved noise immunity
- VBB output for single-ended use
- More than twice as fast as Fairchild
- Function and pinout compatible with Fairchild F100K
- Available in 24-pin CERPACK and 28-pin PLCC packages

DESCRIPTION

The SY100S314 offers five differential line receivers with emitter follower outputs, designed for use in high-performance ECL systems. For single-ended operation, the VBB reference voltage is available. In the single-ended mode, the apparent input threshold of the true inputs is 30mV higher than the threshold of the complementary inputs.

Common mode rejection of +1.0V is achieved through the use of active current sources. If both the true and complement inputs are at the same potential between VEE and VCC, then the complementary outputs will take on a logic HIGH state. Unlike the other members of the Synergy 300K family, the inputs on this device do not have pull-down resistors.

BLOCK DIAGRAM

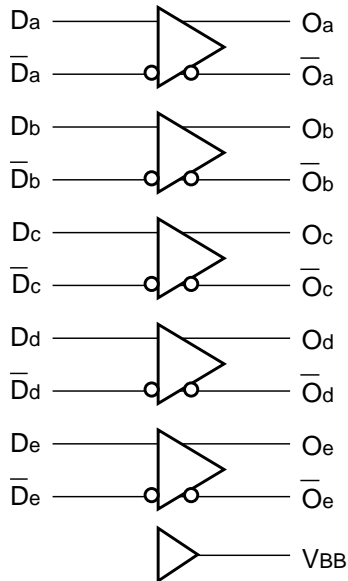

PIN CONFIGURATIONS

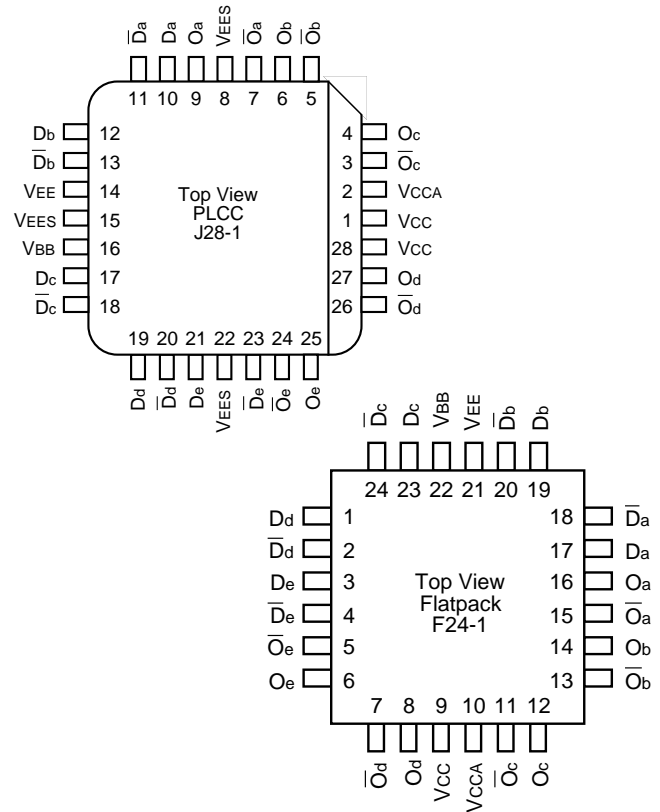

PIN NAMES

Pin	Function
Da - De	Data Inputs
Da-bar - De-bar	Inverting Data Inputs
Oa - Oe	Data Outputs
Oa-bar - Oe-bar	Complementary Data Outputs
VEES	VEE Substrate
VCCA	Vcco for ECL Outputs

LOGIC EQUATION

O = D

DC ELECTRICAL CHARACTERISTICS

VEE = -4.2V to -5.5V unless otherwise specified, VCC = VCCA = GND

Symbol	Parameter	Min.	Typ.	Max.	Unit	Condition
V _{DIFF}	Input Voltage Differential	150	—	—	mV	Required for Full Output Swing
V _{CM}	Common Mode Voltage	—	—	1.0	V	Permissible ±V _{CM} with Respect to V _{BB}
I _{IH}	Input HIGH Current	—	—	50	μA	V _{IN} = V _{IH} (Max.), D _a - D _e = V _{BB} , $\overline{D}_a - \overline{D}_e = V_{IL}$ (Min.)
I _{CBO}	Input Leakage Current	-10	—	—	μA	V _{IN} = V _{EE} , D _a - D _e = V _{BB} , $\overline{D}_a - \overline{D}_e = V_{IL}$ (Min.)
I _{EE}	Power Supply Current	-60	-45	-30	mA	D _a - D _e = V _{BB} , $\overline{D}_a - \overline{D}_e = V_{IL}$ (Min.)

AC ELECTRICAL CHARACTERISTICS**CERPACK**

VEE = -4.2V to -5.5V unless otherwise specified, VCC = VCCA = GND

Symbol	Parameter	TA = 0°C		TA = +25°C		TA = +85°C		Unit	Condition
		Min.	Max.	Min.	Max.	Min.	Max.		
t _{PLH} t _{PHL}	Propagation Delay Data to Output	300	1000	300	1000	300	1000	ps	
t _{TLH} t _{THL}	Transition Time 20% to 80%, 80% to 20%	300	900	300	900	300	900	ps	

PLCC

VEE = -4.2V to -5.5V unless otherwise specified, VCC = VCCA = GND

Symbol	Parameter	TA = 0°C		TA = +25°C		TA = +85°C		Unit	Condition
		Min.	Max.	Min.	Max.	Min.	Max.		
t _{PLH} t _{PHL}	Propagation Delay Data to Output	300	900	300	900	300	900	ps	
t _{TLH} t _{THL}	Transition Time 20% to 80%, 80% to 20%	300	900	300	900	300	900	ps	

TIMING DIAGRAM

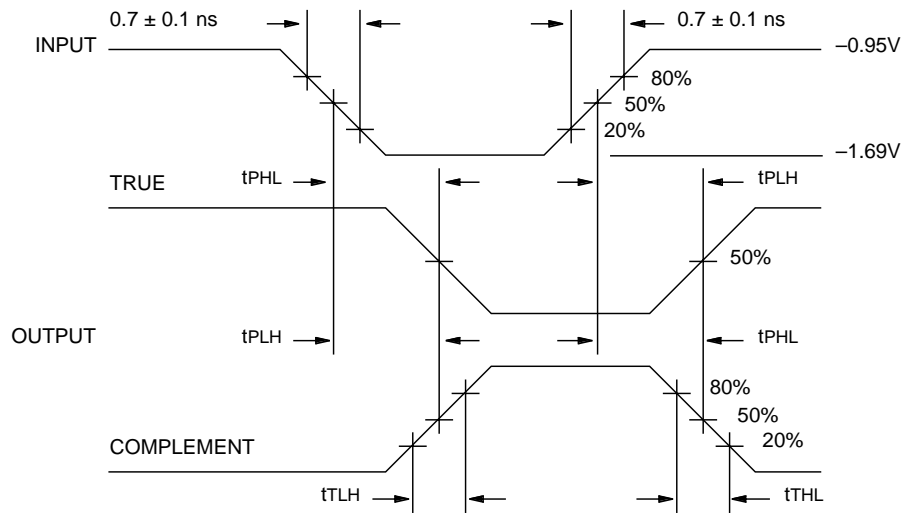

Propagation Delay and Transition Times

NOTE:

$V_{EE} = -4.2V$ to $-5.5V$ unless otherwise specified, $V_{CC} = V_{CCA} = GND$

PRODUCT ORDERING CODE

Ordering Code	Package Type	Operating Range
SY100S314FC	F24-1	Commercial
SY100S314JC	J28-1	Commercial
SY100S314JCTR	J28-1	Commercial

24 LEAD CERPACK (F24-1)

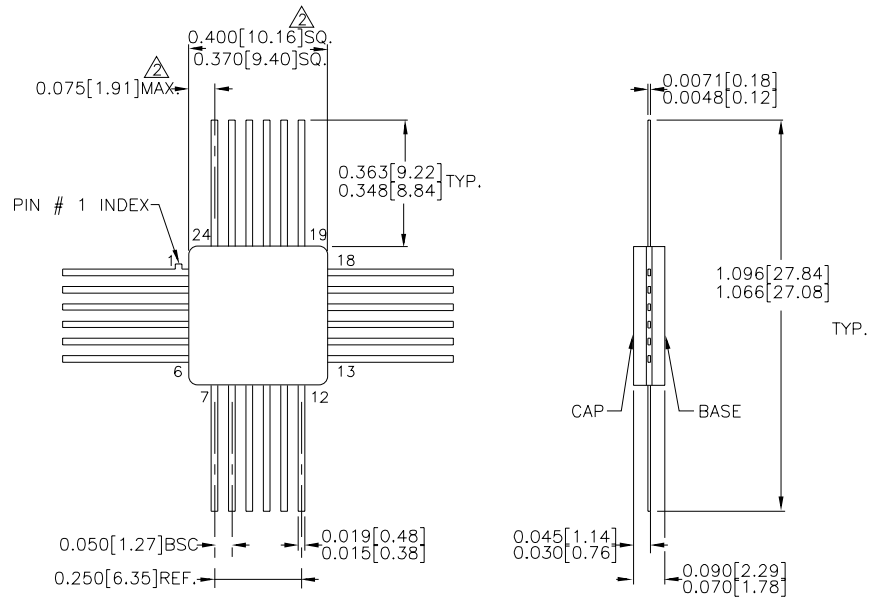

- NOTES:**
1. DIMENSIONS ARE IN INCHES[MM].
 2. \triangle THIS DIMENSION INCLUDES GLASS PROTRUSION AND CAP TO BASE ALIGNMENT TOLERANCES.
 3. DIMENSIONS SHOWN ARE MAX/MIN, WHERE NOTED.

Rev. 03

28 LEAD PLCC (J28-1)

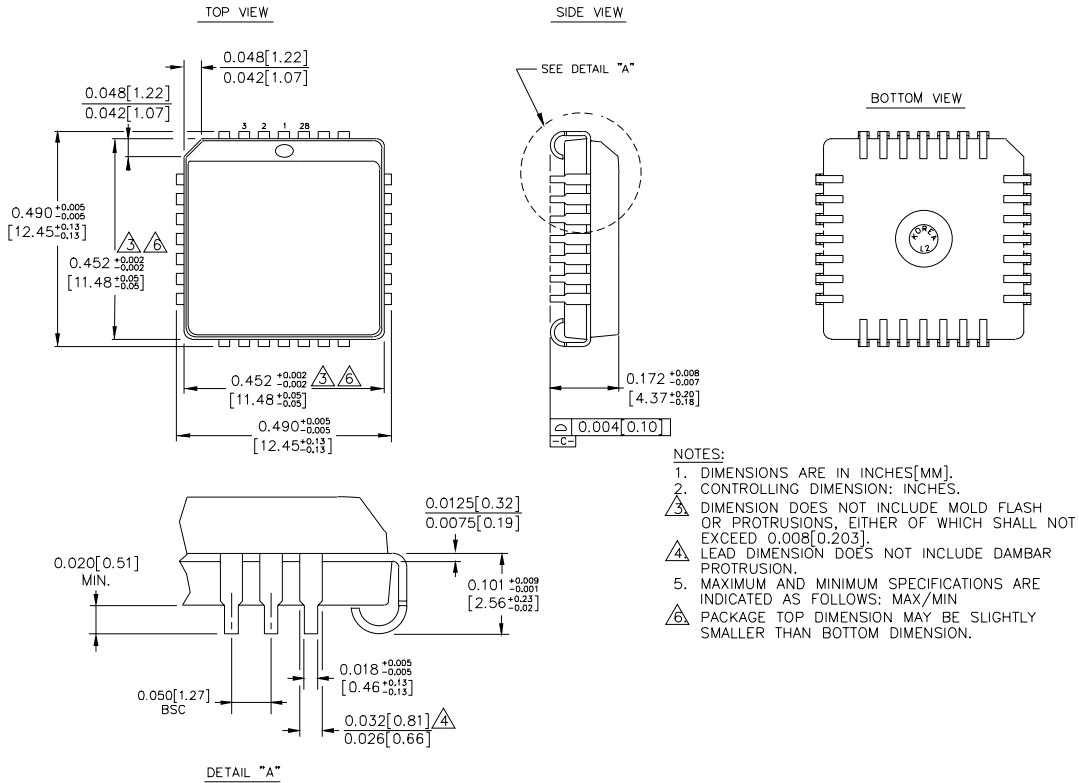

Rev. 03

MICREL-SYNERGY 3250 SCOTT BOULEVARD SANTA CLARA CA 95054 USA

TEL + 1 (408) 980-9191 FAX + 1 (408) 914-7878 WEB <http://www.micrel.com>

This information is believed to be accurate and reliable, however no responsibility is assumed by Micrel for its use nor for any infringement of patents or other rights of third parties resulting from its use. No license is granted by implication or otherwise under any patent or patent right of Micrel Inc.

© 2000 Micrel Incorporated

Looking for pricing, stock, or lifecycle information?

Click below to explore more details on WIN SOURCE:

- ⊖ [View SY100S314FC on WIN SOURCE](#)
- ⊖ [Microchip Technology](#) Information

Optimize Your Supply Chain with WIN SOURCE Solutions

- ✓ Global Sourcing Solution
- ✓ Obsolete Management
- ✓ Cost Control Management
- ✓ Shortage Management
- ✓ Alternative Solution
- ✓ Excess Inventory Management