



**THE DATASHEET OF
SP-2040**





soberton inc.

SP DYNAMIC SPEAKER UNIT

Acoustic Product Specification

Product Number: SP-2040



Release | Revision: B/2017

CONTENTS

This document contains the technical specifications for the dynamic speaker unit.

Page 1
Speaker Electroacoustic Characteristics

General Specifications

Page 2
Reliability Tests

Page 3
Measuring Method (Speaker Mode)

Block Diagram for Measurement Method

Page 4
Frequency Response Curve

Page 5
Dimensions

Page 6
Packing

Dynamic Speaker Electroacoustic Characteristics

Sound Pressure Level

86dB(1W/0.5m) ±3dB at AVE 0.8KHz, 1.0KHz, 1.2KHz, 1.5KHz
Measuring conditions and procedures shown in Fig 1 & Fig 2

Frequency Response Curve

As shown in Figure 3

Resonance Frequency (F0)

650 ±20%Hz

Input Power (Nominal and Maximum)

Rated Noise Power: 1.0W

Short Term Max Power: 2.0W

Frequency Range

F0 ~ 6KHz.

Buzz, Rattle, Etc

Not audible from 650Hz to 20KHz with 2.83V Sine Wave Input

Polarity

When positive voltage is applied to the terminal marked (+), diaphragm should be moved to the front.

Magnet

Rare earth permanent (NdFeB) magnet φ11x2mm

AC Impedance

8Ω ±15%

Distortion

Input Rated Power to 1.0W

Dimension

20x40x8.4mm

General Specifications

Operating Temperature Range

-30°C~+80°C

Storage Temperature Range

-40°C ~ +85°C

Standard Test Conditions

Temperature 5°C~35°C

Relative Humidity 45%~80%(RH)

Air Pressure 860 mbar ~ 1060 mbar

IP Level

No rating



soberton inc.

SP DYNAMIC SPEAKER UNIT

Acoustic Product Specification

Product Number: SP-2040



Release | Revision: B/2017

CONTENTS

This document contains the technical specifications for the dynamic speaker unit.

Page 1
Speaker Electroacoustic Characteristics

General Specifications

Page 2
Reliability Tests

Page 3
Measuring Method (Speaker Mode)

Block Diagram for Measurement Method

Page 4
Frequency Response Curve

Page 5
Dimensions

Page 6
Packing

Reliability Tests

The sound pressure as specified will neither deviate more than $\pm 3\text{dB}$ from the initial value, nor have any significant damage after any of following testing.

High Temperature Test

High Temperature $+85\pm 3^\circ\text{C}$

Duration 96 hours

Low Temperature Test

Low Temperature $-40\pm 3^\circ\text{C}$

Duration 96 hours

Humidity Test

Temperature $+40\pm 3^\circ\text{C}$

Relative Humidity 92%~95%

Duration 96 hours

Vibration

10Hz ~ 55Hz ~ 10Hz sine wave sweep 15 minute 5G(constant)

X, Y, Z 3 directions, 2 hours each, total 6 hours

Temperature Cycle Test

The part will be subjected to 5 cycles. One cycle shall be 12 hours and consist of:

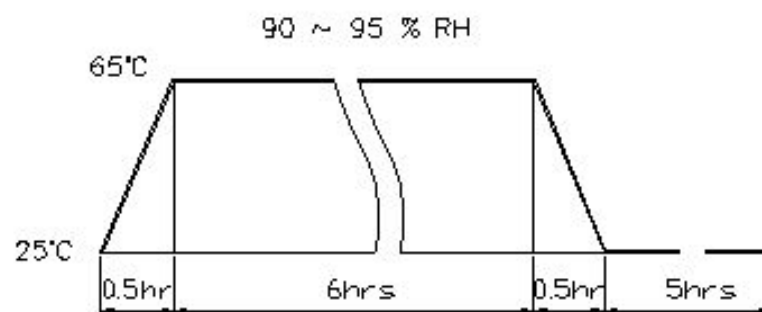

Drop Test

Free drop from 100cm height to the concrete floor
X, Y, Z 6 directions 1 time each, total 6 times

Load Test

Rated Power White noise is applied for 96 hours at room temp.

Max Power Test

Max power 1 minute on - 2 minutes off, 10 cycles

Terminal Strength Test

Capable of withstanding 1kg load for 30 seconds without resulting in any damage or rejection



soberton inc.

SP DYNAMIC SPEAKER UNIT

Acoustic Product Specification

Product Number: SP-2040



Release | Revision: B/2017

CONTENTS

This document contains the technical specifications for the dynamic speaker unit.

Page 1

Speaker Electroacoustic Characteristics

General Specifications

Page 2

Reliability Tests

Page 3

Measuring Method (Speaker Mode)

Block Diagram for Measurement Method

Page 4

Frequency Response Curve

Page 5

Dimensions

Page 6

Packing

Measuring Method (Speaker Mode) (Fig. 1)

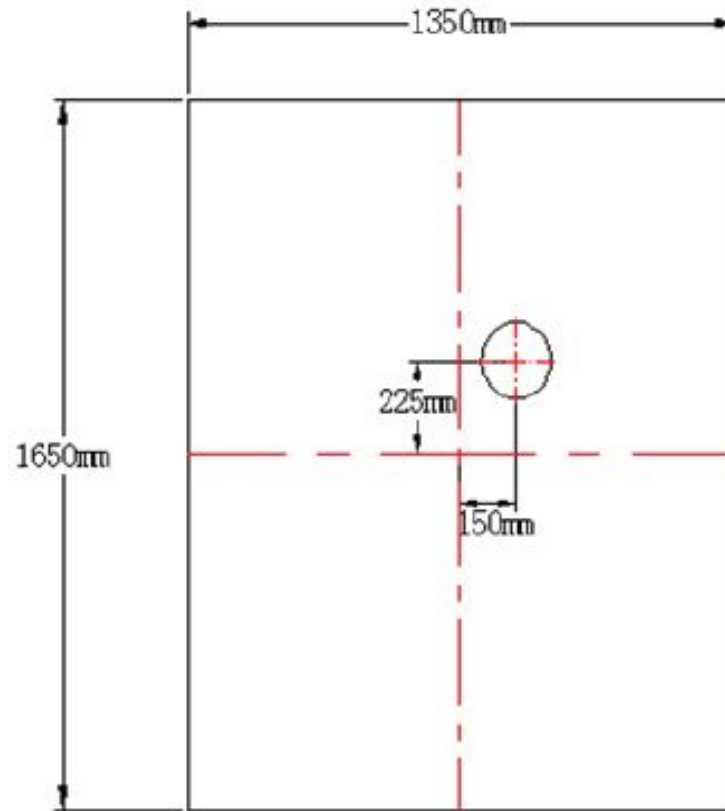

Block Diagram for Measurement Method (Fig. 2)

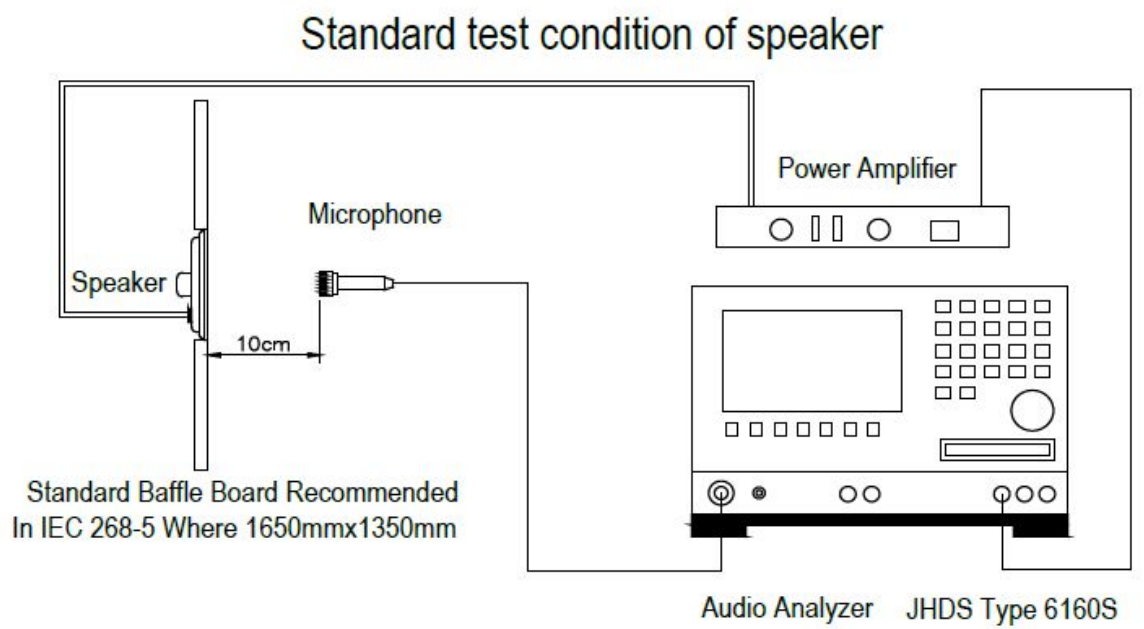



soberton inc.

SP DYNAMIC SPEAKER UNIT

Acoustic Product Specification

Product Number: SP-2040



Release | Revision: B/2017

CONTENTS

This document contains the technical specifications for the dynamic speaker unit.

Page 1

Speaker Electroacoustic Characteristics

General Specifications

Page 2

Reliability Tests

Page 3

Measuring Method (Speaker Mode)

Block Diagram for Measurement Method

Page 4

Frequency Response Curve

Page 5

Dimensions

Page 6

Packing

Frequency Response Curve (Fig. 3)

The swept sine-wave frequency response of a loudspeaker should ideally not deviate more than indicated.

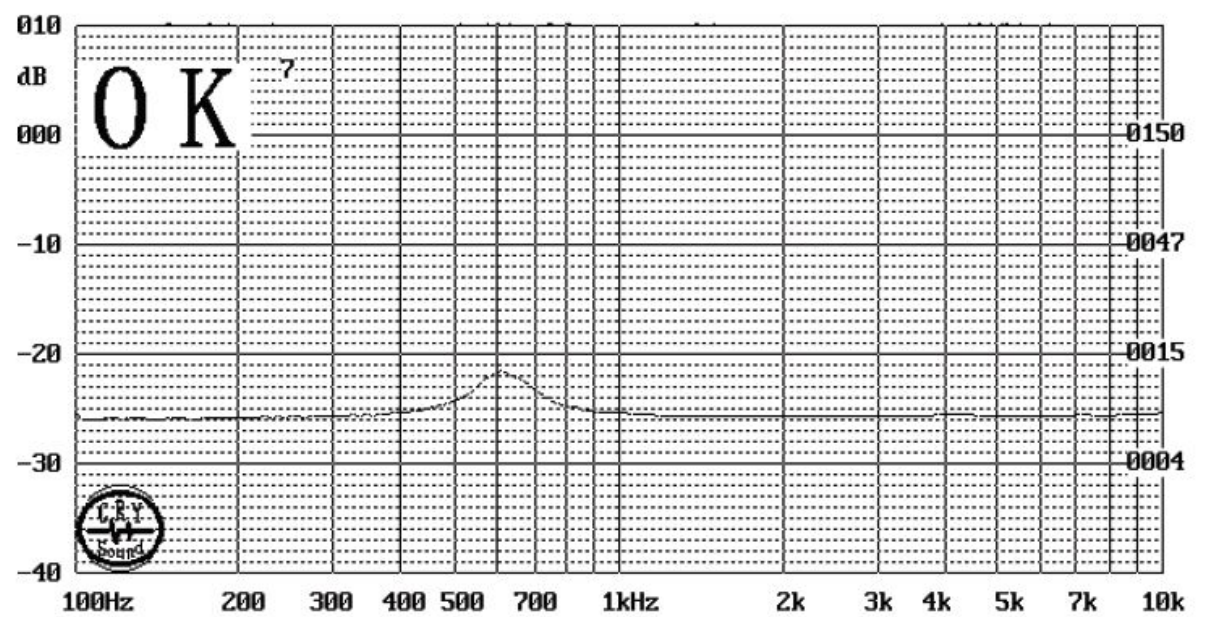
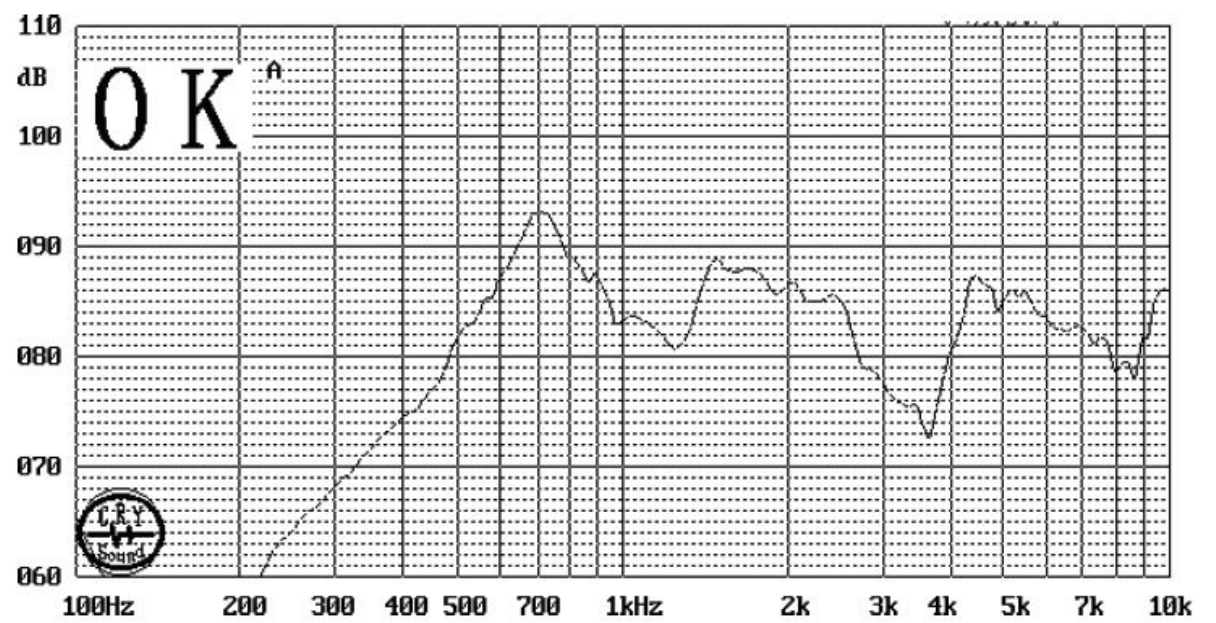



soberton inc.

SP DYNAMIC SPEAKER UNIT

Acoustic Product Specification

Product Number: SP-2040



Release | Revision: B/2017

CONTENTS

This document contains the technical specifications for the dynamic speaker unit.

Page 1

Speaker Electroacoustic Characteristics

General Specifications

Page 2

Reliability Tests

Page 3

Measuring Method (Speaker Mode)

Block Diagram for Measurement Method

Page 4

Frequency Response Curve

Page 5

Dimensions

Page 6

Packing

Dimensions

Tolerance: ± 0.5 (unit: mm)

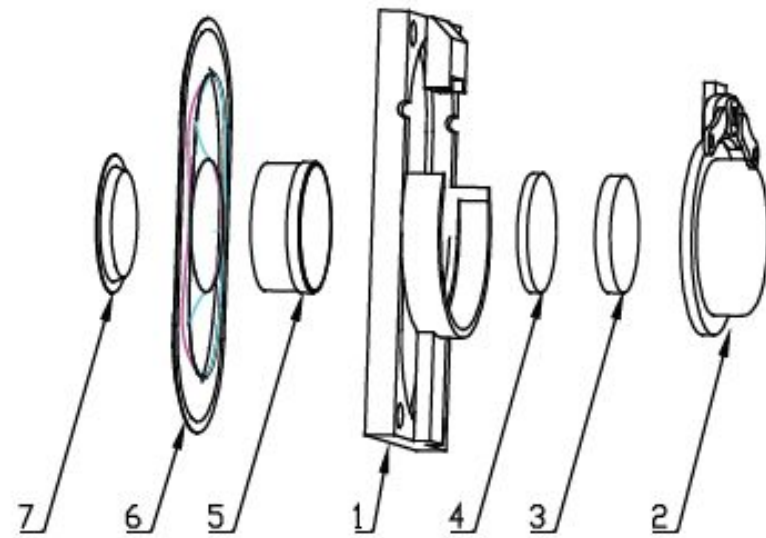
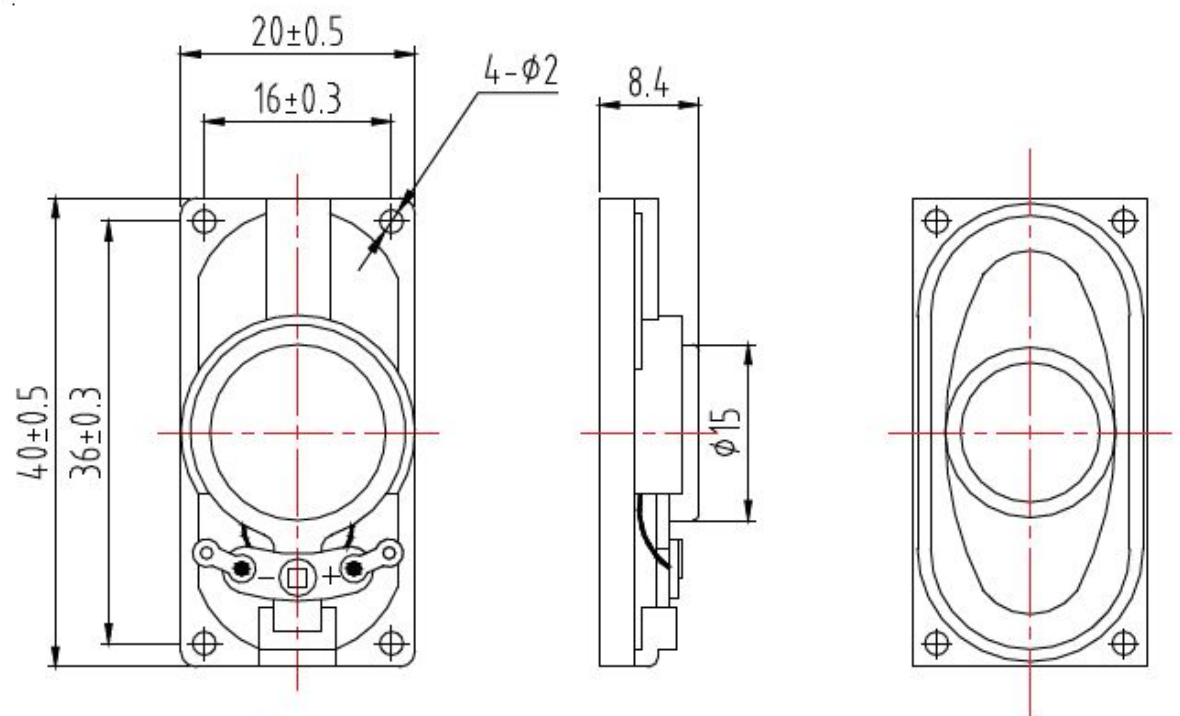

No.	Part Name	Material	Quantity
1	Frame	ABS	1
2	PCB Terminal	Paper Cu	1
3	Magnet	NdFeB	1
4	Plate	SPCC	1
5	Voice Coil	Paper Cu	1
6	Diaphragm	Cloth	1
7	CAP	Paper	1



soberton inc.

SP DYNAMIC SPEAKER UNIT

Acoustic Product Specification

Product Number: SP-2040



Release | Revision: B/2017

CONTENTS

This document contains the technical specifications for the dynamic speaker unit.

Page 1
Speaker Electroacoustic Characteristics

General Specifications

Page 2
Reliability Tests

Page 3
Measuring Method (Speaker Mode)

Block Diagram for Measurement Method

Page 4
Frequency Response Curve

Page 5
Dimensions

Page 6
Packing

Packing

50pcs per tray
10 trays per units, 1 unit per carton
Total: 1000 pcs per box
Size:36.5 x 27 x 31.5cm

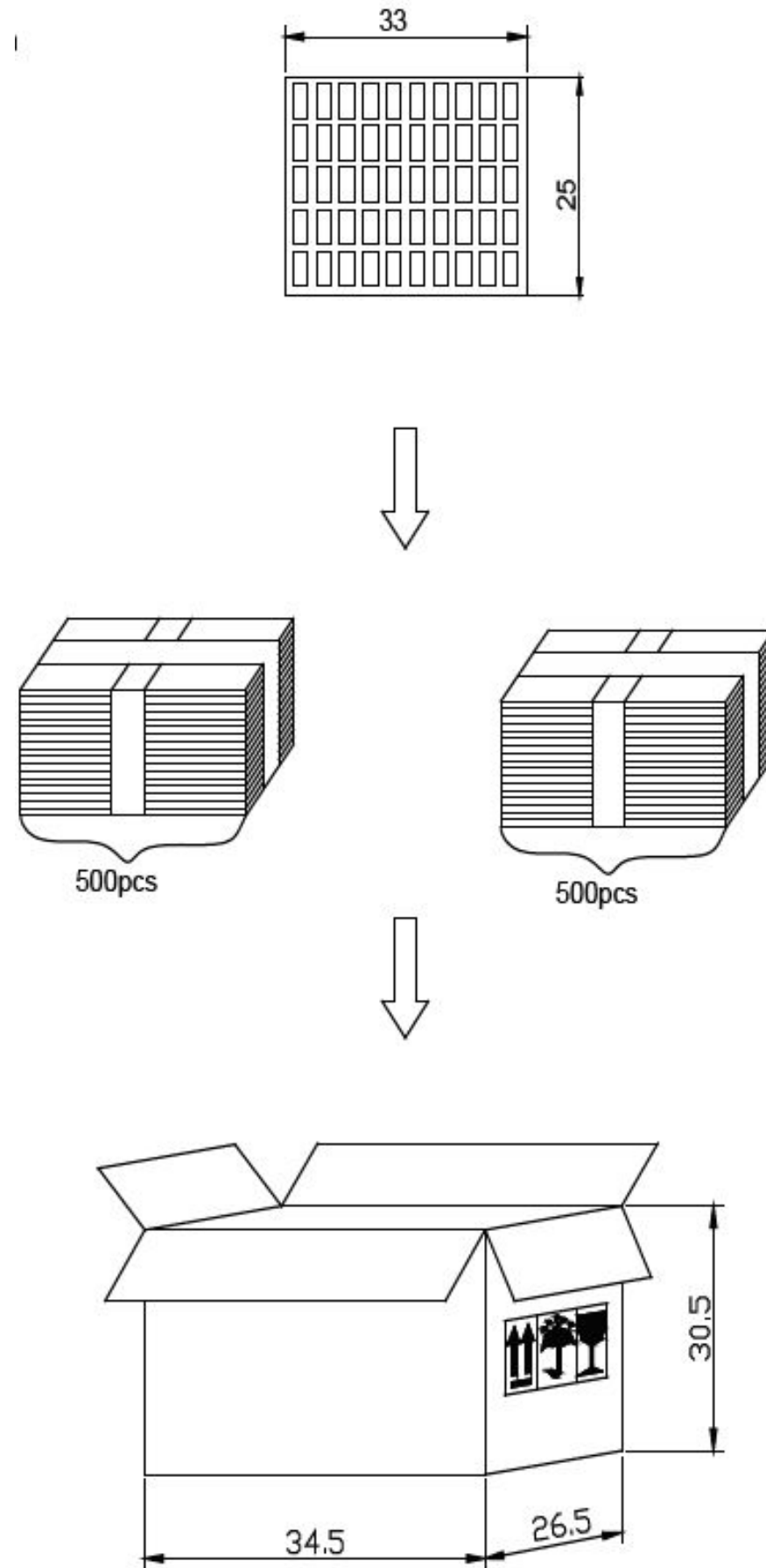

Looking for pricing, stock, or lifecycle information?

Click below to explore more details on WIN SOURCE:

[View SP-2040 on WIN SOURCE](#)

[Soberton Inc. Information](#)

Optimize Your Supply Chain with WIN SOURCE Solutions

- ✓ Global Sourcing Solution
- ✓ Obsolete Management
- ✓ Cost Control Management
- ✓ Shortage Management
- ✓ Alternative Solution
- ✓ Excess Inventory Management