



# THE DATASHEET OF SM5S16A



**Transient Voltage Suppressors family**  
**5 Watts TVS /Zener Diode**

**DO-218**

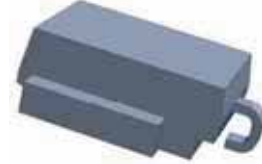

**FEATURES**

- High current capability
- Low Forward Voltage Drop
- Low reverse current
- Low thermal resistance
- Excellent high temperature stability
- Low power loss and high efficiency
- High forward surge capability
- Meets ISO7637-2 surge specification
- Meets MSL level 1, per J-STD-020, LF maximum peak of 260 °C
- P/N suffix V means AEC-Q101 qualified, eg: SM5S10AV
- P/N suffix V means Halogen-free

**PIN INFORMATION**

Polarity: Heatsink is anode

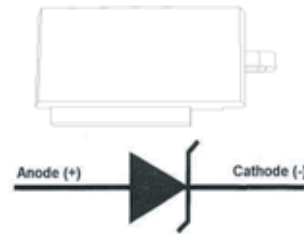

**For Bidirectional use C or CA suffix for types SM5S10 thru SM5S36, Electrical characteristics apply in both direction.**

**APPLICATIONS**

- High peak power
- High-temperature
- Clamping diode
- Load switching and lighting

**MARKING INFORMATION**



**MACHANICAL DATA**

- Case: DO-218 outline plastic package
- Terminals: Matte tin plated, solderable per MIL-STD-750, Method 2026, J-STD-002 and JESD 22-B102
- Molding Compound Flammability Rating: UL94-0
- High temperature soldering guaranteed: 260°C 10second
- HE3 suffix meets JESD 201 class 2 whisker test
- Polarity : Heatsink is anode
- Corresponds to taping packages. (750PCS/Reel 3000PCS/Cartron)

PRIMARY CHARACTERISTICS	
VWM	10 V to 36 V
VBR	11.1 V to 44.2 V
PPPM (10 x 1000 uS)	3600 W
PPPM (10 x 10000 uS)	2800 W
PD	5 W
IFSM	500 A

### Maximum Ratings (TA = 25 °C unless otherwise noted)

Parameter		Symbol	Value	Units
Peak pulse power dissipation	10/1000 $\mu$ s waveform	PPPM	3600	W
	10/10 000 $\mu$ s waveform		2800	
Power dissipation on infinite heatsink at TC = 25 °C		PD	5.0	W
Peak forward surge current 8.3 ms single half sine-wave		IFSM	500	A
Operating junction and storage temperature range		TJ, TSTG	-55 to +175	°C

### Electrical Characteristics (TA = 25 °C unless otherwise noted)

Part Number	Breakdown Voltage VBR (V)		Test Current IT (mA)	Stand-OFF Voltage VWM (V)	Maximum Reverse Leakage at VWM ID ( $\mu$ A)	Maximum Leakage at VWM TJ = 175 °C ID ( $\mu$ A)	Max. Peak Pulse Current at 10/1000 $\mu$ s Waveform (A)	Maximum Clamping Voltage at IPPM Vc (V)
	Min.	Max.						
SM5S10	11.1	13.6	5.0	10.0	15	250	191	18.8
SM5S10A		12.3	5.0	10.0	15	250	211	17.0
SM5S11	12.2	14.9	5.0	11.0	10	150	179	20.1
SM5S11A		13.5	5.0	11.0	10	150	198	18.2
SM5S12	13.3	16.3	5.0	12.0	10	150	164	22.0
SM5S12A		14.7	5.0	12.0	10	150	181	19.9
SM5S13	14.4	17.6	5.0	13.0	10	150	151	23.8
SM5S13A		15.9	5.0	13.0	10	150	167	21.5
SM5S14	15.6	19.1	5.0	14.0	10	150	140	25.8
SM5S14A		17.2	5.0	14.0	10	150	155	23.2
SM5S15	16.7	20.4	5.0	15.0	10	150	134	26.9
SM5S15A		18.5	5.0	15.0	10	150	148	24.4
SM5S16	17.8	21.8	5.0	16.0	10	150	125	28.8
SM5S16A		19.7	5.0	16.0	10	150	138	26.0
SM5S17	18.9	23.1	5.0	17.0	10	150	118	30.5
SM5S17A		20.9	5.0	17.0	10	150	130	27.6
SM5S18	20.0	24.4	5.0	18.0	10	150	112	32.2
SM5S18A		22.1	5.0	18.0	10	150	123	29.2
SM5S20	22.2	27.1	5.0	20.0	10	150	101	35.8
SM5S20A		24.5	5.0	20.0	10	150	111	32.4
SM5S22	24.4	29.8	5.0	22.0	10	150	91	39.4
SM5S22A		26.9	5.0	22.0	10	150	101	35.5
SM5S24	26.7	32.6	5.0	24.0	10	150	84	43.0
SM5S24A		29.5	5.0	24.0	10	150	93	38.9
SM5S26	28.9	35.3	5.0	26.0	10	150	77	46.6
SM5S26A		31.9	5.0	26.0	10	150	86	42.1
SM5S28	31.1	38.0	5.0	28.0	10	150	72	50.1
SM5S28A		34.4	5.0	28.0	10	150	79	45.4
SM5S30	33.3	40.7	5.0	30.0	10	150	67	53.5
SM5S30A		36.8	5.0	30.0	10	150	74	48.4
SM5S33	36.7	44.9	5.0	33.0	10	150	61	59.0
SM5S33A		40.6	5.0	33.0	10	150	68	53.3
SM5S36	40.0	48.9	5.0	36.0	10	150	56	64.3
SM5S36A		44.2	5.0	36.0	10	150	62	58.1

**Note:** For all types maximum VF = 1.8 V at IF = 100 A measured on 8.3 ms single half sine-wave or equivalent square wave, duty cycle = 4 pulses per minute maximum

**Thermal Characteristics (TA = 25 °C unless otherwise noted)**

Parameter	Symbol	Value	Units
Typical thermal resistance, junction to case	$R_{\theta JC}$	1.1	°C/W

**RATING AND CHARACTERISTICS CURVES ( SM5S SERIES )**

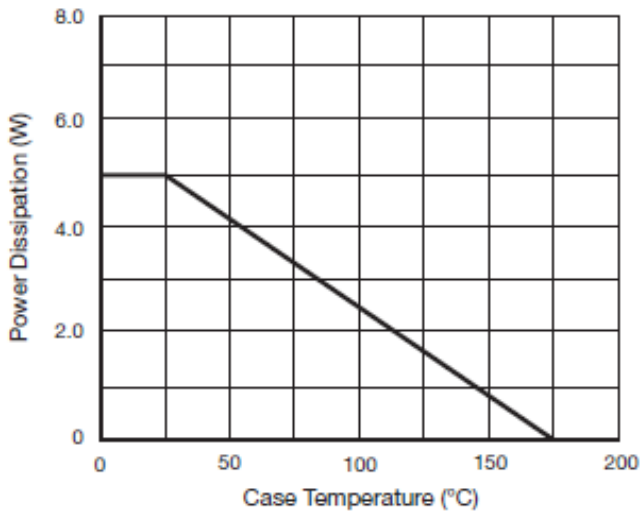

Fig. 1 - Power Derating Curve

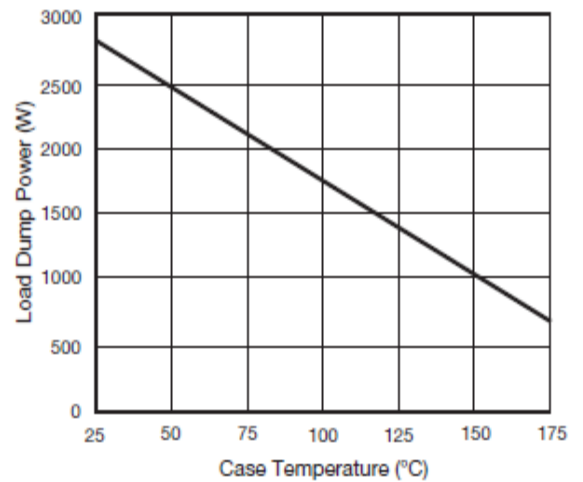

Fig. 2 - Load Dump Power Characteristics (10 ms Exponential Waveform)

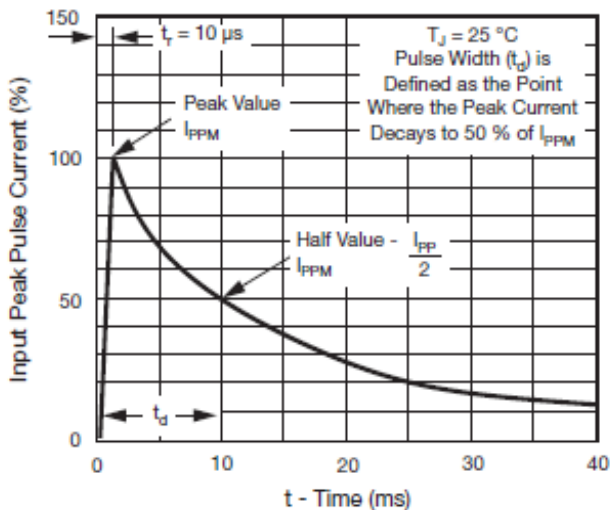

Fig. 3 - Pulse Waveform

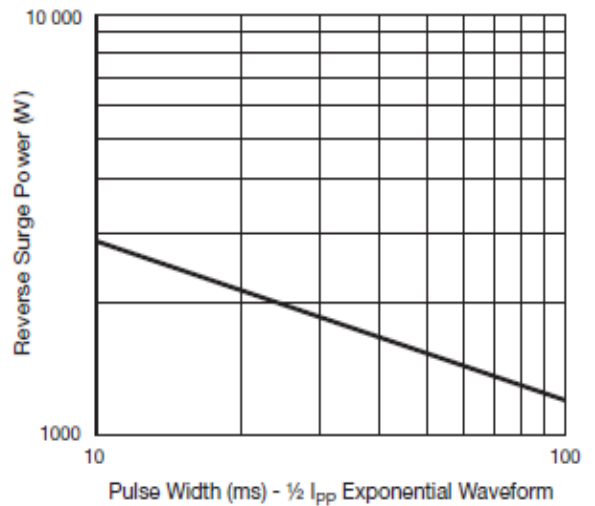

Fig. 4 - Reverse Power Capability

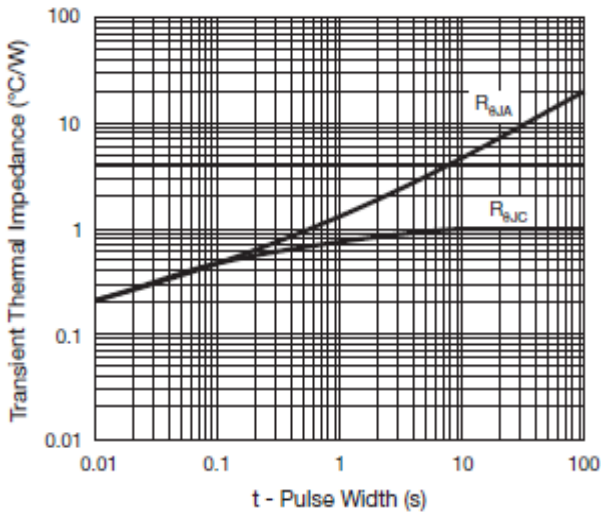

Fig. 5 - Typical Transient Thermal Impedance

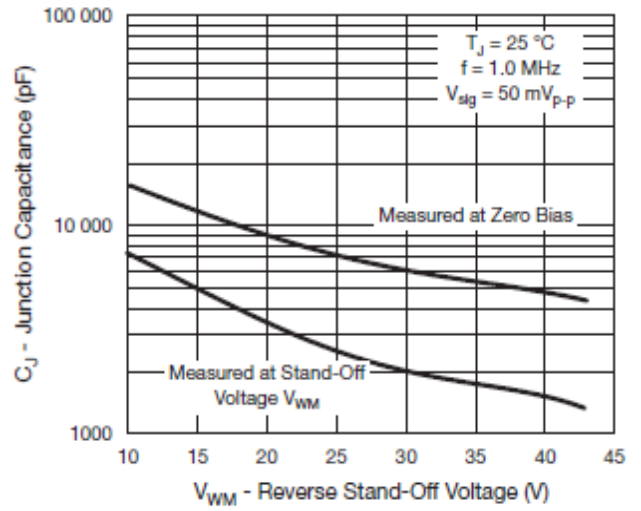
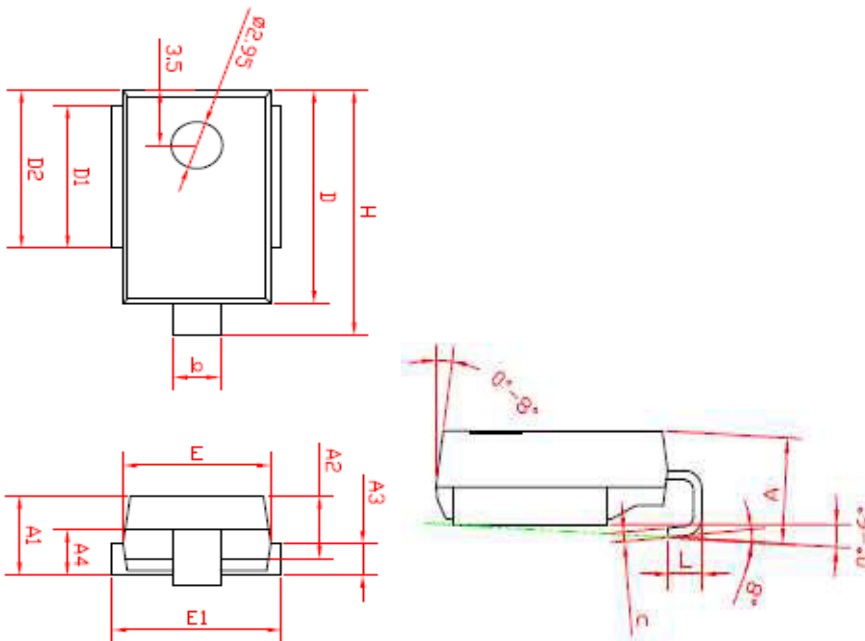

Fig. 6 - Typical Junction Capacitance

**Physical Dimensions**



**DO-218**

SYMBOLS Unit:mm	DIMENSIONS IN MILLIMETERS	
	MIN	MAX
A	4.70	5.70
A1	4.70	5.25
A2	3.45	4.25
A3	1.70	2.50
A4	2.65	3.55
b	2.30	4.00
c	0.45	0.90
D	13.20	13.80
D1	9.00	11.00
D2	9.70	10.30
E	8.20	8.80
E1	9.50	11.50
H	15.00	16.00
L	1.50	2.50

**Foot Print Recommendation (mm)**

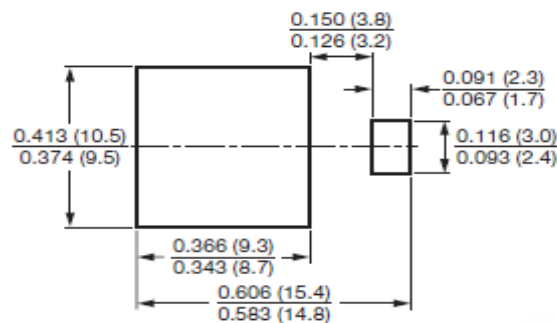

# Marking Description

1) SM5Sxx/SM5SxxA :

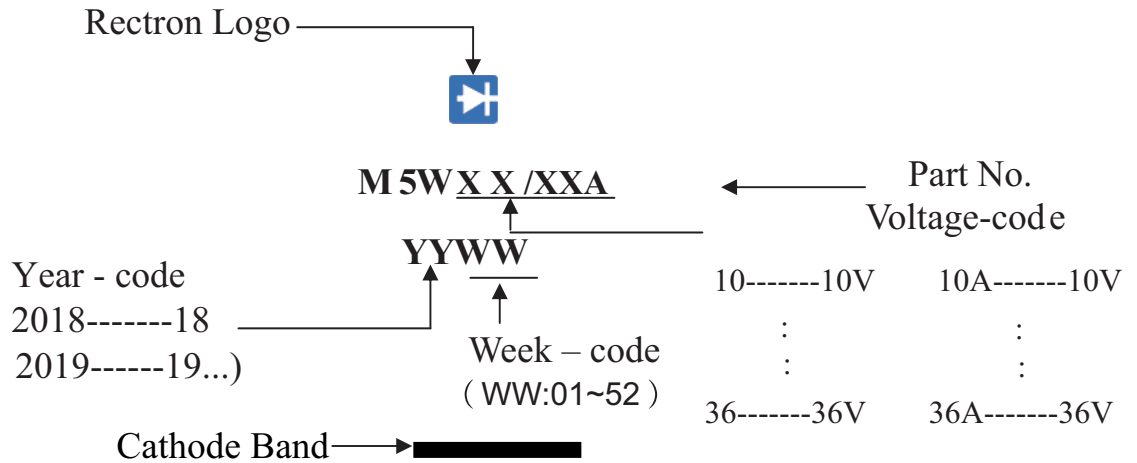

2) SM5SxxCA :

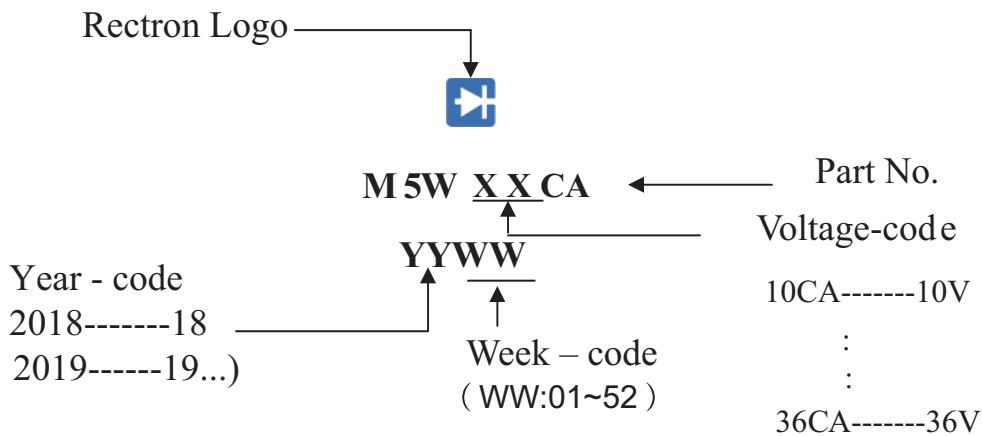



## DISCLAIMER NOTICE

Rectron Inc reserves the right to make changes without notice to any product specification herein, to make corrections, modifications, enhancements or other changes. Rectron Inc or anyone on its behalf assumes no responsibility or liability for any errors or inaccuracies. Data sheet specifications and its information contained are intended to provide a product description only. "Typical" parameters which may be included on RECTRON data sheets and/ or specifications can and do vary in different applications and actual performance may vary over time. Rectron Inc does not assume any liability arising out of the application or use of any product or circuit.

Rectron products are not designed, intended or authorized for use in medical, life-saving implant or other applications intended for life-sustaining or other related applications where a failure or malfunction of component or circuitry may directly or indirectly cause injury or threaten a life without expressed written approval of Rectron Inc. Customers using or selling Rectron components for use in such applications do so at their own risk and shall agree to fully indemnify Rectron Inc and its subsidiaries harmless against all claims, damages and expenditures.

## Looking for pricing, stock, or lifecycle information?

Click below to explore more details on WIN SOURCE:

-  [View SM5S16A on WIN SOURCE](#)
-  [Rectron USA Information](#)

## Optimize Your Supply Chain with WIN SOURCE Solutions

-  Global Sourcing Solution
-  Obsolete Management
-  Cost Control Management
-  Shortage Management
-  Alternative Solution
-  Excess Inventory Management