

Thermal Management for FC- and FW-Series 250 W—300 W Board-Mounted Power Modules

Introduction

Board-mounted power modules (BMPMs) enhance the capabilities of advanced computer and communications systems by providing flexible power architectures; however, proper cooling of the power modules is required for reliable and consistent operation. Maintaining the operating case temperature (T_c) within the specified range keeps internal component temperatures within their specifications. This, in turn, helps keep the expected mean time between failures (MTBF) from falling below the specified rating.

Tyco's FC- and FW- Series 250 W to 300 W BMPMs are designed with high efficiency as a primary goal. The 5 V output units have typical full load efficiencies of 83%, which result in less heat dissipation and lower operating temperatures. Also, these modules use temperature resistant components, such as ceramic capacitors, that do not exhibit wearout behavior during prolonged exposure to high temperatures, as do aluminum electrolytic capacitors.

This application note provides the necessary information to verify that adequate cooling is present in a given operating environment. This information is applicable to all Tyco 250 W to 300 W BMPMs in the 4.6 in. x 2.4 in. x 0.5 in. package.

Basic Thermal Management

Proper cooling can be verified by measuring the case temperature of the module (T_c) at the location indicated in Figure 1. Note that the view in Figure 1 is of the metal surface of the module (the pin locations shown are for reference). T_c must not exceed 100 °C while operating in the final system configuration. After the module has reached thermal equilibrium, the measurement can be made with a thermocouple or surface probe. If a heat sink is mounted to the case, make the measurement as close as possible to the indicated position, taking into account the contact resistance between the mounting surface and the heat sink (see Heat Sink section).

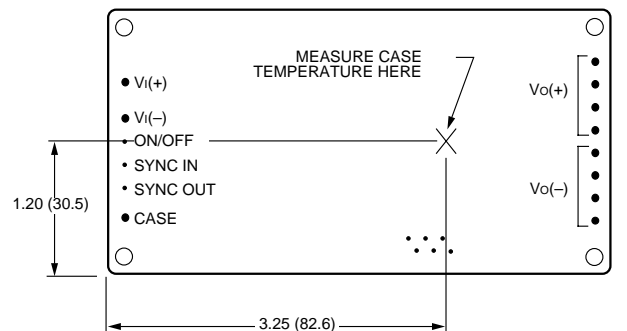

8-1303a

Figure 1. Case Temperature Measurement (Metal Side)

While this is a valid method of checking for proper thermal management, it is only usable if the final system configuration exists and can be used as a test environment. The graphs on the accompanying pages provide guidelines to predict the thermal performance of the module for typical configurations that include heat sinks in natural or forced airflow environments. However, due to differences between the test setup and the final system environment, the module case temperature must always be checked in the final system configuration to verify proper operation.

Basic Thermal Management (continued)

The goal of thermal management is to transfer the heat dissipated by the module to the surrounding environment. The amount of power dissipated by the module as heat (P_D) is the difference between the input power (P_I) and the output power (P_O) as shown by the equation below:

$$P_D = P_I - P_O$$

Also, module efficiency (η) is defined as the ratio of output power to input power as shown by the equation below:

$$\eta = P_O / P_I$$

The input power term can be eliminated by the combination of these two equations to yield the equation below:

$$P_D = P_O (1 - \eta) / \eta$$

This equation can be used to calculate the module power dissipation. However, efficiency is a nonlinear function of the module input voltage (V_I) and output current (I_O). Typically, a plot of power dissipation versus output current over three different line voltages is given in each module-specific data sheet. This is because each module has a different power dissipation curve. A typical curve of this type is shown below in Figure 2 for a FW300A1 Power Module (5 V output voltage).

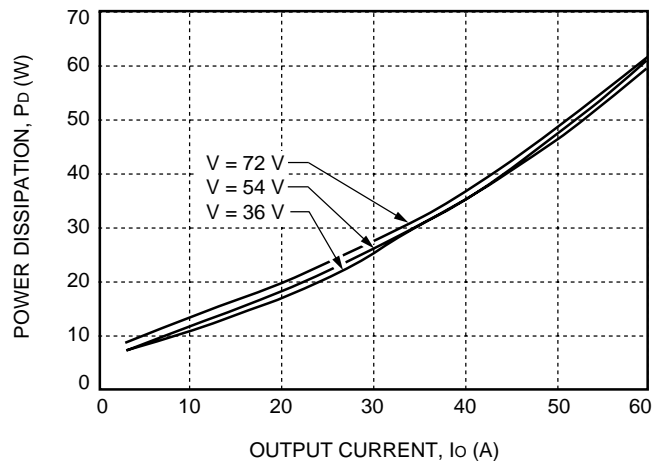

8-1313

Figure 2. FW300A1 Power Dissipation vs. Output Current

Module Derating

Experimental Setup

The derating curves in the following figures were obtained from measurements obtained in an experimental apparatus shown in Figure 3. Note that the module and the printed-wiring board (PWB) onto which it was mounted were vertically oriented. The passage has a rectangular cross-section. The clearance between the top of the module and the facing PWB was kept constant at 0.5 in.

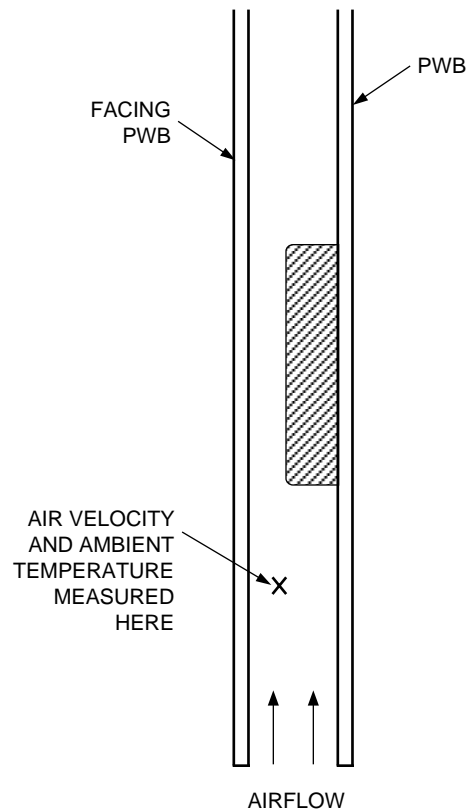

8-690a

Figure 3. Experimental Test Setup

Module Derating (continued)

Convection Without Heat Sinks

Increasing airflow over the module enhances heat transfer via convection. Figures 4 and 5 show the maximum power that can be dissipated by the module without exceeding the maximum case temperature versus local ambient temperature (T_A) for natural convection through 800 ft./min. A natural convection condition is produced when air is moved only through the buoyancy effects produced by a temperature gradient between the module and surrounding air. In the test setup used, natural convection airflow was measured at 10 ft./min. to 20 ft./min., whereas systems in which these power modules may be used typically generate natural convection airflow rates of 60 ft./min. due to other heat dissipating components in the system. The 100 ft./min. to 800 ft./min. curves are for airflow added externally to the test setup, usually through the use of fans. Note that there is a thermal performance improvement when the long axis of the module is perpendicular to the airflow direction (transverse orientation).

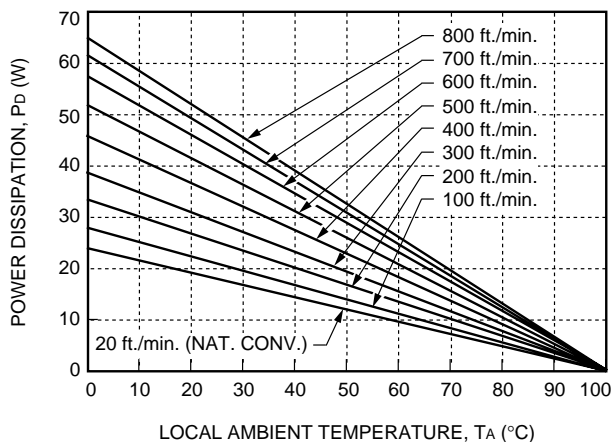

8-1314

Figure 4. Convection Power Derating with No Heat Sink; Airflow Along Length (Longitudinal)

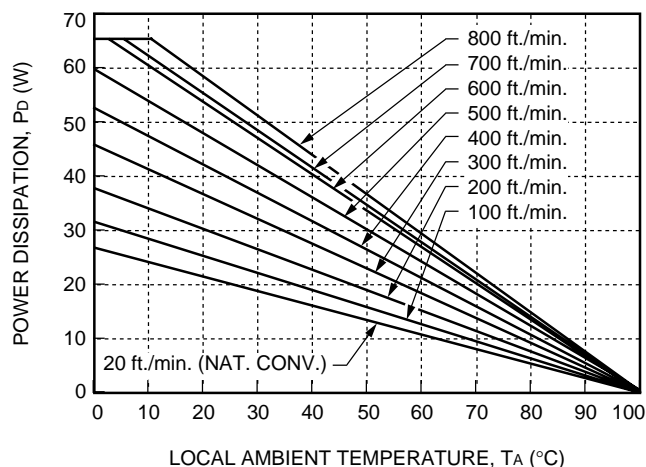

8-1315

Figure 5. Convection Power Derating with No Heat Sink; Airflow Along Width (Transverse)

Figures 4 and 5 can be used to determine the appropriate airflow for a given set of operating conditions as shown in the following examples.

Example 1: Airflow Required to Maintain T_c

What is the minimum airflow necessary for a FW300A1 in the transverse orientation, operating at 54 V input, an output current of 50 A, and a maximum ambient temperature of 35 °C?

Solution:

Given: $V_I = 54$ V, $I_o = 50$ A, $T_A = 35$ °C

Determine P_D (Figure 2): $P_D = 46$ W

Determine Airflow (Figure 5): $v = 800$ ft./min.

Example 2: Maximum Power Output

What is the maximum power output for a FW300A1 in the longitudinal orientation, operating at 54 V input, in an environment that provides 600 ft./min. with a maximum ambient temperature of 40 °C?

Solution:

Given: $V_I = 54$ V, $v = 600$ ft./min., $T_A = 40$ °C

Determine P_D (Figure 4): $P_D = 34$ W

Determine I_o (Figure 2): $I_o = 40$ A

Calculate $P_o = (V_o) * (I_o) = 5 * 40 = 200$ W

Although the above two examples use 100 °C as the operating case temperature, for extremely high reliability applications, one may design to a lower case temperature as shown later in Example 4.

Module Derating (continued)

Heat Sink Configuration

Several standard heat sinks are available for the FC- and FW-Series 250 W—300 W BMPMs, as shown in Figures 6 and 7. The heat sinks mount to the top surface of the module with M3 x 0.5 screws torqued to 5 in.-lb. (0.56 N-m). Placing a thermally conductive dry pad or thermal grease between the case and the heat sink minimizes contact resistance (typically 0.1 °C/W to 0.3 °C/W) and temperature drop. All heat sink curve data taken had such a dry pad present.

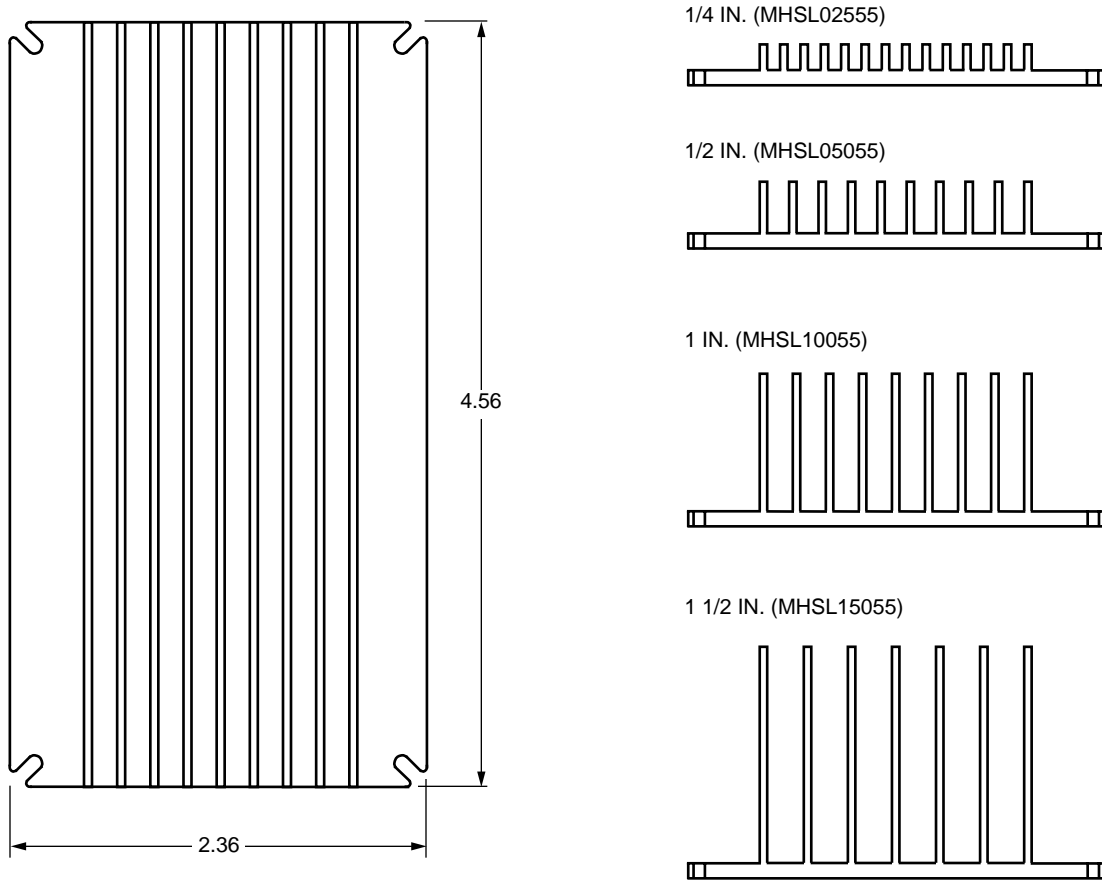

8-1316

Figure 6. Heat Sinks with Longitudinal Fins

Module Derating (continued)

Heat Sink Configuration (continued)

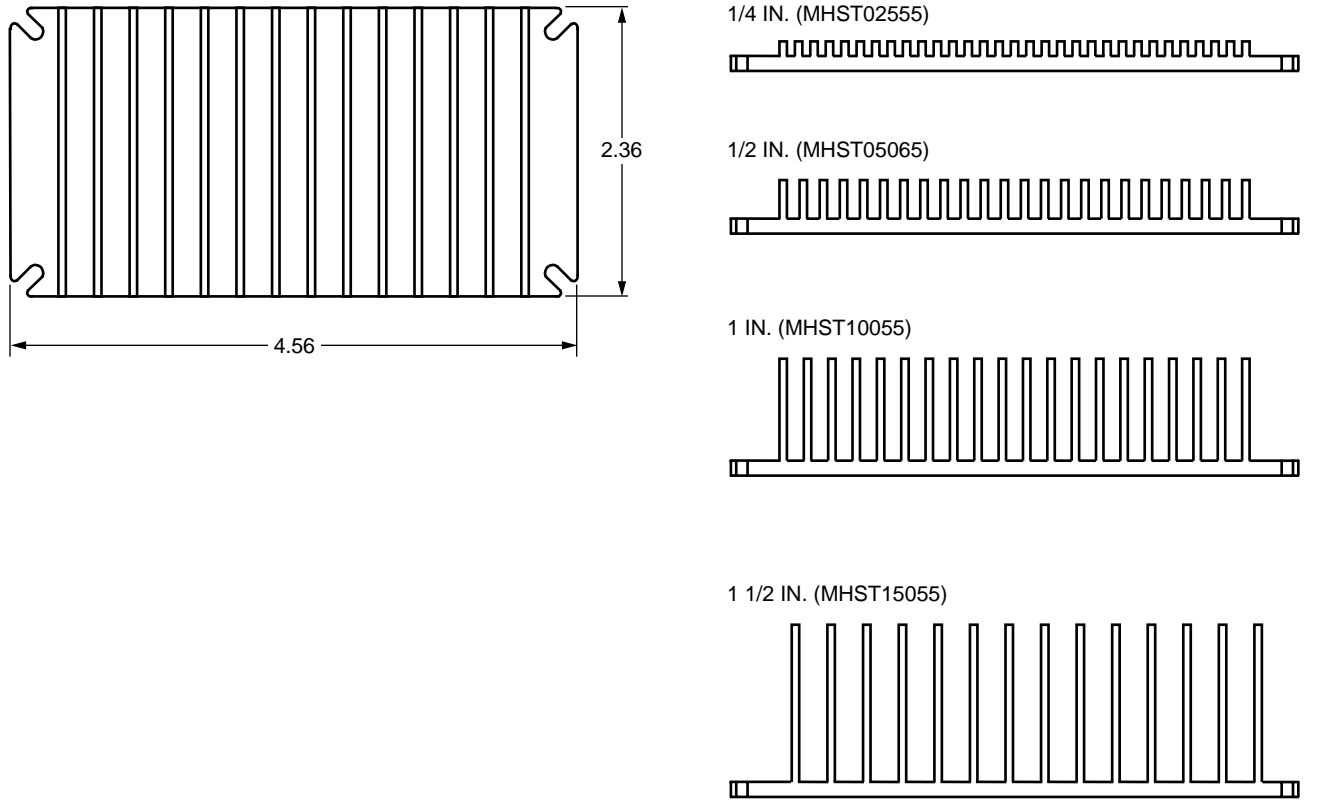

8-1317

Figure 7. Heat Sinks with Transverse Fins

Nomenclature for this family of heat sinks is as follows:

MHSxyyy55

where: x = fin orientation; longitudinal (L) or transverse (T)

yyy = heat sink height (in 100ths of inch)

For example, MHST10055 is a heat sink that is transverse mounted (see Figure 7) for a 4.6 in. x 2.4 in. module with a heat sink height of 1 in. The “M” prefix represents a heat sink kit with metric hardware.

Module Derating (continued)

Natural Convection With Heat Sinks

Figures 8 and 9 show the power derating for a module in natural convection with the heat sinks shown in Figures 6 and 7. Natural convection is the heat transfer produced when air in contact with a hot surface is heated, causing it to rise. An open environment is required with no external forces moving the air. Figures 8 and 9 apply when the module is the only source of heat present in the system, generating airflow of approximately 10 ft./min. to 20 ft./min. Again, a typical system with other heat dissipating components will usually generate higher airflows in natural convection.

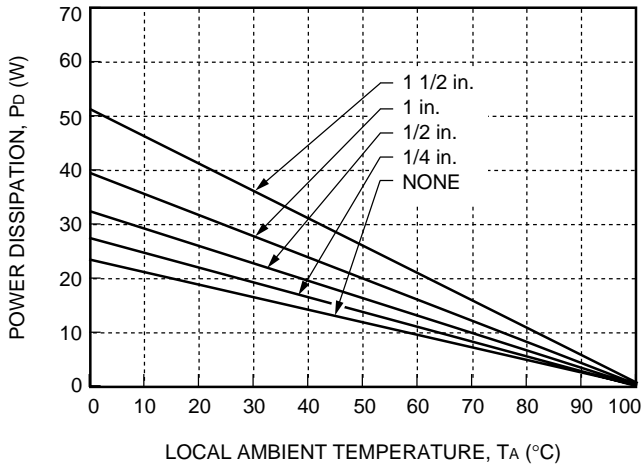
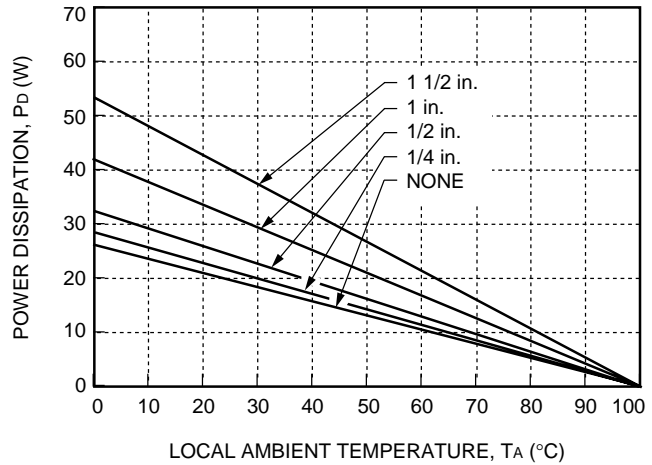

Figure 8. Heat Sink Power Derating Curves
Natural Convection, Longitudinal Orientation



8-1319

Figure 9. Heat Sink Power Derating Curves
Natural Convection, Transverse Orientation

Figures 8 and 9 can be used to predict which heat sink a module will require in a natural convection environment, as shown in the following example.

Example 3: Sizing a Heat Sink

What heat sink would be appropriate for a transverse mounted FW300A1 in a natural convection environment at 54 V input and 2/3 load with a maximum ambient temperature of 35 °C?

Solution:

Given: $V_I = 54 \text{ V}$, $I_o = 2/3(60) = 40 \text{ A}$, $T_A = 35 \text{ °C}$

Determine P_D (Figure 2): $P_D = 35 \text{ W}$

Determine Heat Sink (Figure 9):

1 1/2 in. heat sink allows up to $T_A = 35 \text{ °C}$

Basic Thermal Model

Another approach for analyzing thermal performance is to model the overall thermal resistance of the module. This presentation method is especially useful when considering heat sinks, since their performance is also typically given as a resistance. Total module thermal resistance (θ) is defined as the maximum case temperature rise ($\Delta T_{c,max}$) divided by the module power dissipation (P_D):

$$\theta = \Delta T_{c,max} / P_D$$

This can be represented as an equivalent circuit as shown in Figure 10. In this model P_D , $\Delta T_{c,max}$, and θ are analogous to current flow, voltage drop, and electrical resistance, respectively, in Ohm's law. Also, $\Delta T_{c,max}$ is defined as the difference between the inlet ambient temperature (T_A) and the module case temperature (T_c) as defined in Figures 3 and 1 respectively.

$$\Delta T_{c,max} = T_c - T_A$$

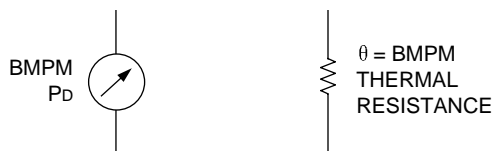

8-695

Figure 10. Basic Thermal Resistance Module

For FC- and FW-Series 250 W to 300 W BMPMs, the module's thermal resistance values versus air velocity have been determined experimentally and are plotted in Figures 11 and 12 for a unit without a heat sink and for the various heat sink configurations (see Figures 6 and 7). Note that the highest values on the curves represent natural convection. In a system with free-flowing air and other heat sources, there may be additional air-flow.

It is important to point out that the thermal resistances shown in Figures 11 and 12 are for heat transfer from the sides and bottom of the module as well as the top side with the attached heat sink; therefore, the case-to-ambient thermal resistances shown will generally be lower than the resistance of the heat sink by itself. The data in Figures 11 and 12 were taken with a thermally conductive dry pad between the case and the heat sink to minimize contact resistance (typically 0.1 °C/W to 0.3 °C/W).

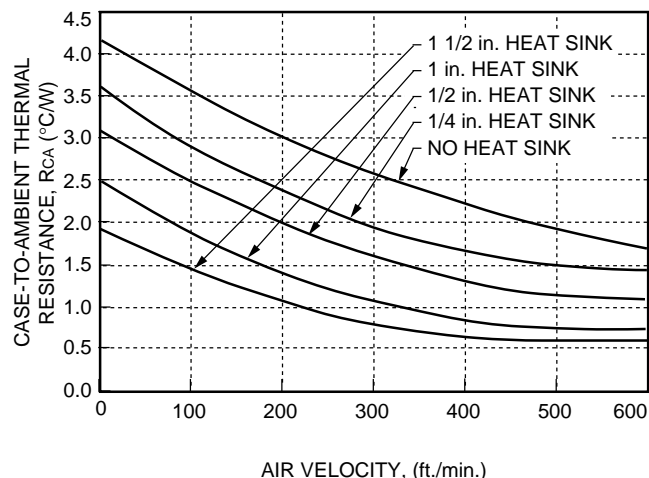

8-1320

Figure 11. Case-to-Ambient Thermal Resistance Curves, Longitudinal Orientation

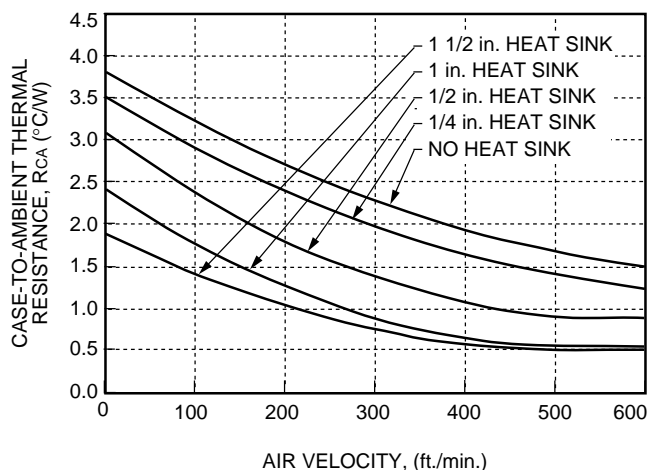

8-1321

Figure 12. Case-to-Ambient Thermal Resistance Curves; Transverse Orientation

Basic Thermal Model (continued)

Figures 11 and 12 can be used to determine thermal performance under various airflow and heat sink configurations as shown in the following examples.

Example 4: Airflow Required to Maintain Tc

Although the maximum case temperature for the FC- and FW-Series 250 W—300 W BMPMs is 100 °C, one may want to limit the maximum case temperature to a lower value for extremely high reliability. If an 85 °C case temperature is desired, what are the allowable minimum airflow/heat sink combinations necessary for a transverse mounted FW300A1 operating at 54 V input line and an output current of 50 A with a maximum ambient of 40 °C?

Solution:

$$\begin{aligned} \text{Given: } V_i &= 54 \text{ V, } I_o = 50 \text{ A, } T_A = 40 \text{ }^\circ\text{C} \\ \text{Determine } P_D \text{ (Figure 2): } &P_D = 46 \text{ W} \\ \theta &= (T_C - T_A) / P_D \\ &= (85 - 40) / 46 \\ &= 1.0 \text{ }^\circ\text{C/W} \end{aligned}$$

Use Figure 12 to determine air velocity:

No heat sink:	$v \gg 600$ ft./min.
1/4 in. heat sink:	$v \gg 600$ ft./min.
1/2 in. heat sink:	$v = 450$ ft./min.
1 in. heat sink:	$v = 260$ ft./min.
1 1/2 in. heat sink:	$v = 205$ ft./min.

Example 5: Determining Tc

Suppose that there is an air velocity of 600 ft./min. available for the configuration stated in Example 4. What is the case temperature for the various heat sink configurations?

Solution:

$$\begin{aligned} \text{Given: } V_i &= 54 \text{ V, } I_o = 50 \text{ A, } T_A = 40 \text{ }^\circ\text{C, } v = 600 \text{ ft./min.} \\ \text{Determine } P_D \text{ (Figure 2): } &P_D = 46 \text{ W} \\ T_C &= (\theta \times P_D) + T_A \end{aligned}$$

Using thermal resistances (θ) from Figure 12:

$$\begin{aligned} \text{No heat sink: } \theta &= 1.5 \text{ }^\circ\text{C/W} \\ T_C &= (1.5 \times 46) + 40 = 109 \text{ }^\circ\text{C} \\ \text{1/4 in. heat sink: } \theta &= 1.2 \text{ }^\circ\text{C/W} \\ T_C &= (1.2 \times 46) + 40 = 95 \text{ }^\circ\text{C} \\ \text{1/2 in. heat sink: } \theta &= 0.9 \text{ }^\circ\text{C/W} \\ T_C &= (0.9 \times 46) + 40 = 81 \text{ }^\circ\text{C} \\ \text{1 in. heat sink: } \theta &= 0.6 \text{ }^\circ\text{C/W} \\ T_C &= (0.6 \times 46) + 40 = 68 \text{ }^\circ\text{C} \\ \text{1 1/2 in. heat sink: } \theta &= 0.5 \text{ }^\circ\text{C/W} \\ T_C &= (0.5 \times 46) + 40 = 63 \text{ }^\circ\text{C} \end{aligned}$$

In this configuration, the module would not operate within the maximum case temperature of 100 °C unless a heat sink was attached.

Thermal Shutdown

The FC- and FW-Series 250 W—300 W BMPMs has a latching thermal shutdown circuit designed to turn off the module if it is operated in excess of the maximum case temperature. Recovery from thermal shutdown is accomplished by cycling the dc input power off for at least 1.0 s, or toggling the primary referenced ON/OFF signal for at least 1.0 s.



Tyco Electronics Power Systems, Inc.
3000 Skyline Drive, Mesquite, TX 75149, USA
+1-800-526-7819 FAX: +1-888-315-5182
(Outside U.S.A.: +1-972-284-2626, FAX: +1-972-284-2900)
<http://power.tycoelectronics.com>



Tyco Electronics Corporation reserves the right to make changes to the product(s) or information contained herein without notice. No liability is assumed as a result of their use or application. No rights under any patent accompany the sale of any such product(s) or information.



© 2001 Tyco Electronics Corporation, Harrisburg, PA. All International Rights Reserved.
Printed in U.S.A.

July 1996
TN96-009EPS



Looking for pricing, stock, or lifecycle information?

Click below to explore more details on WIN SOURCE:

-  [View MHSL15040 on WIN SOURCE](#)
-  [ABB Embedded Power Information](#)

Optimize Your Supply Chain with WIN SOURCE Solutions

-  Global Sourcing Solution
-  Obsolete Management
-  Cost Control Management
-  Shortage Management
-  Alternative Solution
-  Excess Inventory Management