

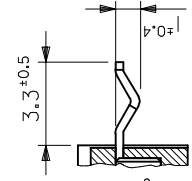

**THE DATASHEET OF**  
**0530140210+**

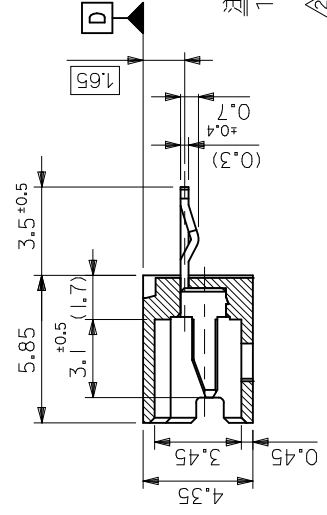

10 9 8 7 6 5 4 3

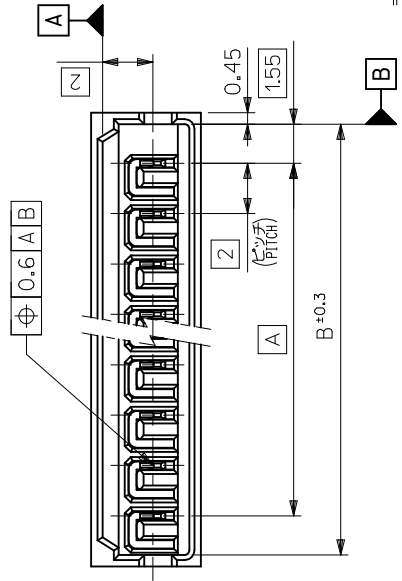
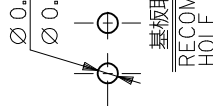

注記 NOTES

1. 嵌合相手 : 51100 MATES WITH : 51100
- 3極以上のキンク加工に、ストレートの順に、1極おき KINK TO BE ADDED SOLDER TAIL. (FF)
- 2極用の穴は、2極品以上は2ヶと異なる LOCKING HOLE : 2 M

2極品のキンク形状図  
KINK FORM FOR 2 CKTS.  
両方のテールにキンクを施す。  
SOLDER TAIL KINK SHOULD BE ADDED ON BOTH TAILS.

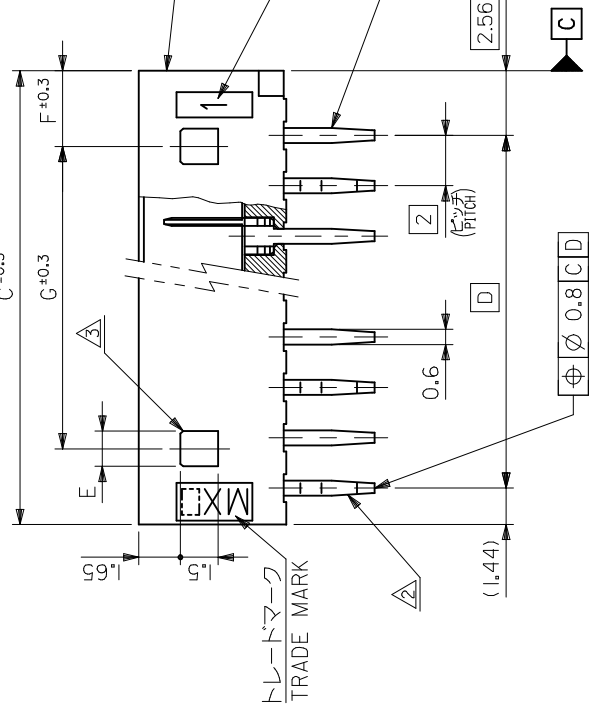

26	3	1.4	28
24	3	1.4	26
22	3	1.4	24
20	3	1.4	22
18	3	1.4	20
16	3	1.4	18
14	3	1.4	16
12	3	1.4	14
10	3	1.4	12
8	3	1.4	10
6	3	1.4	8
4	3	1.4	6
—	4	3.4	4
—	3	1.4	2
G	F	E	D

ワイパー  
WAFER  
(ナイロン66、ガラス入り)  
(NYLON66, GLASS FILLED)  
UL94V-0

回路番号  
CIRCUIT NO.

ピン  
PIN  
(リン青銅、錫メッキ)  
(PHOSPHOR BRONZE,  
PRE-TINNED, t=0.52)

トレードマーク  
TRADE MARK

GENERAL TOLERANCES (UNLESS SPECIFIED)	10 UNDER	± 0.2
	10 OVER 30 UNDER	± 0.25
	30 OVER	± 0.3
	ANGULAR	± 3 °
DRAFT WHERE APPLICABLE MUST REMAIN WITHIN DIMENSIONS		
DESCRIPTION	REV	
EC NO: J2009-0377	H	
DRM:NABEI		
CHKD:THARYAMA		
APR:NUKITA		
2008/08/18		
2008/08/19		
REVISED		
DIMENSION STYLE		
MM ONLY	5	
DRAWN BY	M. HENMI	DATE
CHECKED BY	M. FUKUSHIMA	'92/03/06
APPROVED BY	M. ENOMOTO	'92/05/28
MATERIAL NO.		
SEE TABLE		
THIS DRAWING CONTAINS 1		
INCORPORATED AND SHOULD		

tb\_frame A3 J\_ME\_S Rev. E 2006/04/15

## Looking for pricing, stock, or lifecycle information?

Click below to explore more details on WIN SOURCE:

 [View 0530140210+ on WIN SOURCE](#)

 [Molex, LLC Information](#)

## Optimize Your Supply Chain with WIN SOURCE Solutions

-  Global Sourcing Solution
-  Obsolete Management
-  Cost Control Management
-  Shortage Management
-  Alternative Solution
-  Excess Inventory Management