



**THE DATASHEET OF
SI4362-B1B-FM**



HIGH-PERFORMANCE, LOW-CURRENT RECEIVER

Features

- Frequency range = 142–1050 MHz
- Receive sensitivity = –126 dBm
- Modulation
 - (G)FSK, 4(G)FSK, (G)MSK
 - OOK and ASK
- Low active power consumption
 - 10/13 mA RX
- Ultra low current powerdown modes
 - 30 nA shutdown, 50 nA standby
- Data rate = 100 bps to 1 Mbps
- Fast wake and hop times
- Power supply = 1.8 to 3.6 V
- Excellent selectivity performance
 - 60 dB adjacent channel
 - 75 dB blocking at 1 MHz
- Antenna diversity and T/R switch control
- Highly configurable packet handler
- RX 64 byte FIFOs
- Auto frequency control (AFC)
- Automatic gain control (AGC)
- Low BOM
- Low battery detector
- Temperature sensor
- 20-Pin QFN package



Applications

- Smart metering (802.15.4g and MBus)
- Remote control
- Home security and alarm
- Telemetry
- Garage and gate openers
- Remote keyless entry
- Home automation
- Industrial control
- Sensor networks
- Health monitors
- Electronic shelf labels

Description

Silicon Labs Si4362 devices are high-performance, low-current receivers covering the sub-GHz frequency bands from 142 to 1050 MHz. The radios are part of the EZRadioPRO[®] family, which includes a complete line of transmitters, receivers, and transceivers covering a wide range of applications. All parts offer outstanding sensitivity of –126 dBm while achieving extremely low active and standby current consumption. The 60 dB adjacent channel selectivity with 12.5 kHz channel spacing ensures robust receive operation in harsh RF conditions, which is particularly important for narrowband operation. RX current of 10 mA coupled with extremely low standby current and fast wake times ensure extended battery life in the most demanding applications. The devices are compliant with all worldwide regulatory standards: FCC, ETSI, and ARIB.

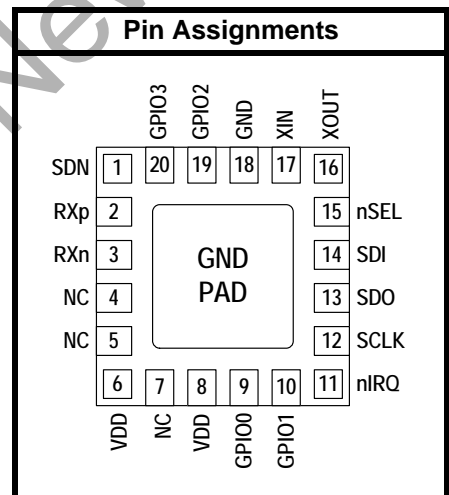

Patents pending

Si4362

Functional Block Diagram

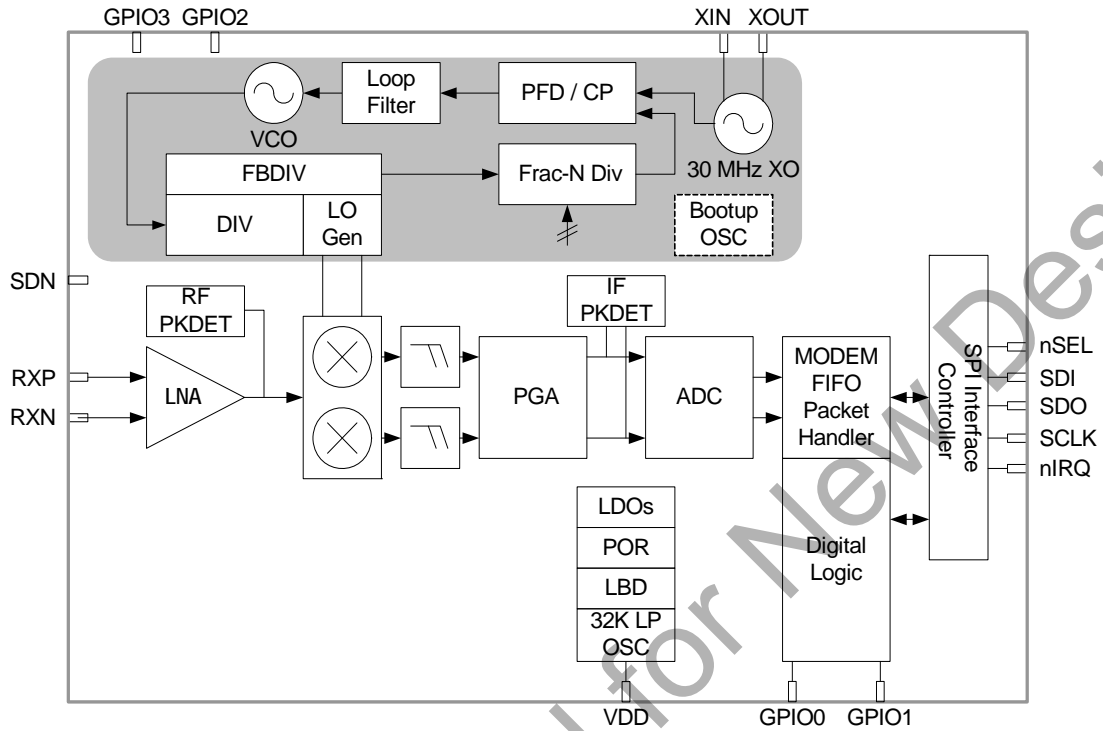

TABLE OF CONTENTS

<u>Section</u>	<u>Page</u>
1. Electrical Specifications	4
1.1. Definition of Test Conditions	11
2. Functional Description	12
3. Controller Interface	13
3.1. Serial Peripheral Interface (SPI)	13
3.2. Fast Response Registers	15
3.3. Operating Modes and Timing	15
3.4. Application Programming Interface (API)	19
3.5. Interrupts	19
3.6. GPIO	20
4. Modulation and Hardware Configuration Options	21
4.1. Hardware Configuration Options	21
4.2. Preamble Length	22
5. Internal Functional Blocks	24
5.1. RX Chain	24
5.2. RX Modem	25
5.3. Synthesizer	27
5.4. Crystal Oscillator	29
6. Data Handling and Packet Handler	30
6.1. RX FIFOs	30
6.2. Packet Handler	31
7. RX Modem Configuration	32
8. Auxiliary Blocks	32
8.1. Wake-up Timer and 32 kHz Clock Source	32
8.2. Low Duty Cycle Mode (Auto RX Wake-Up)	34
8.3. Temperature, Battery Voltage, and Auxiliary ADC	35
8.4. Low Battery Detector	36
8.5. Antenna Diversity	36
9. Pin Descriptions: Si4362	37
10. Ordering Information	39
11. Package Outline: Si4362	40
12. PCB Land Pattern: Si4362	42
13. Top Marking	44
13.1. Si4362 Top Marking	44
13.2. Top Marking Explanation	44
Document Change List	45
Contact Information	46

1. Electrical Specifications

Table 1. Recommended Operating Conditions

Parameter	Symbol	Test Condition	Min	Typ	Max	Unit
Ambient Temperature	T_A		-40	25	85	°C
Supply Voltage	V_{DD}		1.8		3.6	V
I/O Drive Voltage	V_{GPIO}		1.8		3.6	V

Table 2. DC Characteristics¹

Parameter	Symbol	Test Condition	Min	Typ	Max	Unit
Supply Voltage Range	V_{DD}		1.8	3.3	3.6	V
Power Saving Modes	$I_{Shutdown}$	RC Oscillator, Main Digital Regulator, and Low Power Digital Regulator OFF	—	30	—	nA
	$I_{Standby}$	Register values maintained and RC oscillator/WUT OFF	—	50	—	nA
	$I_{SleepRC}$	RC Oscillator/WUT ON and all register values maintained, and all other blocks OFF	—	900	—	nA
	$I_{SleepXO}$	Sleep current using an external 32 kHz crystal. ²	—	1.7	—	μA
	$I_{Sensor-LBD}$	Low battery detector ON, register values maintained, and all other blocks OFF	—	1	—	μA
	I_{Ready}	Crystal Oscillator and Main Digital Regulator ON, all other blocks OFF	—	1.8	—	mA
TUNE Mode Current	I_{Tune_RX}	RX Tune, High Performance Mode	—	7.2	—	mA
RX Mode Current	I_{RXH}	High Performance Mode	—	13.7	—	mA
	I_{RXL}	Low Power Mode ²	—	10.7	—	mA

Notes:

1. All specifications guaranteed by production test unless otherwise noted. Production test conditions and max limits are listed in the "Production Test Conditions" section of "1.1. Definition of Test Conditions" on page 11.
2. Guaranteed by qualification. Qualification test conditions are listed in the "Qualification Test Conditions" section in "1.1. Definition of Test Conditions" on page 11.

Table 3. Synthesizer AC Electrical Characteristics¹

Parameter	Symbol	Test Condition	Min	Typ	Max	Unit
Synthesizer Frequency Range (Si4362)	F_{SYN}		142	—	175	MHz
			284	—	350	MHz
			420	—	525	MHz
			850	—	1050	MHz
Synthesizer Frequency Resolution ³	$F_{\text{RES-960}}$	850–1050 MHz	—	28.6	—	Hz
	$F_{\text{RES-525}}$	420–525 MHz	—	14.3	—	Hz
	$F_{\text{RES-350}}$	283–350 MHz	—	9.5	—	Hz
	$F_{\text{RES-175}}$	142–175 MHz	—	4.7	—	Hz
Synthesizer Settling Time ⁴	t_{LOCK}	Measured from exiting Ready mode with XOSC running to any frequency. Including VCO Calibration.	—	50	—	μs

Notes:

1. All specification guaranteed by production test unless otherwise noted. Production test conditions and max limits are listed in the "Production Test Conditions" section in "1.1. Definition of Test Conditions" on page 11.
2. For applications that use the major bands covered by Si4362, customers should use those parts instead of Si4362.
3. Default API setting for modulation deviation resolution is double the typical value specified.
4. Guaranteed by qualification. Qualification test conditions are listed in the "Qualification Test Conditions" section in "1.1. Definition of Test Conditions" on page 11.

Table 4. Receiver AC Electrical Characteristics¹

Parameter	Symbol	Test Condition	Min	Typ	Max	Unit
RX Frequency Range (Si4362)	F_{RX}		142	—	175	MHz
			284	—	350	MHz
			420	—	525	MHz
			850	—	1050	MHz
RX Sensitivity	$P_{RX_0.5}$	(BER < 0.1%) (500 bps, GFSK, BT = 0.5, $\Delta f = \pm 250\text{Hz}$) ³	—	-126	—	dBm
	P_{RX_40}	(BER < 0.1%) (40 kbps, GFSK, BT = 0.5, $\Delta f = \pm 20\text{ kHz}$) ³	—	-110	—	dBm
	P_{RX_100}	(BER < 0.1%) (100 kbps, GFSK, BT = 0.5, $\Delta f = \pm 50\text{ kHz}$) ¹	—	-106	—	dBm
	P_{RX_125}	(BER < 0.1%) (125 kbps, GFSK, BT = 0.5, $\Delta f = \pm 62.5\text{ kHz}$) ³	—	-105	—	dBm
	P_{RX_500}	(BER < 0.1%) (500 kbps, GFSK, BT = 0.5, $\Delta f = \pm 250\text{ kHz}$) ³	—	-97	—	dBm
	$P_{RX_9.6}$	(PER 1%) (9.6 kbps, 4GFSK, BT = 0.5, $\Delta f = \pm 2.4\text{ kHz}$) ^{3,4}	—	-110	—	dBm
	P_{RX_1M}	(PER 1%) (1 Mbps, 4GFSK, BT = 0.5, inner deviation = 83.3 kHz) ^{3,4}	—	-88	—	dBm
	P_{RX_OOK}	(BER < 0.1%, 4.8 kbps, 350 kHz BW, OOK, PN15 data) ³	—	-110	—	dBm
		(BER < 0.1%, 40 kbps, 350 kHz BW, OOK, PN15 data) ³	—	-104	—	dBm
		(BER < 0.1%, 120 kbps, 350 kHz BW, OOK, PN15 data) ³	—	-99	—	dBm
RX Channel Bandwidth ⁵	BW		1.1	—	850	kHz
BER Variation vs Power Level ³	P_{RX_RES}	Up to +5 dBm Input Level	—	0	0.1	ppm
RSSI Resolution	RES_{RSSI}		—	± 0.5	—	dB

Notes:

1. All specification guaranteed by production test unless otherwise noted. Production test conditions and max limits are listed in the "Production Test Conditions" section in "1.1. Definition of Test Conditions" on page 11.
2. For applications that use the major bands covered by Si4362, customers should use those parts instead of Si4362.
3. Guaranteed by qualification. BER is specified for the 450–470 MHz band. Qualification test conditions are listed in the "Qualification Test Conditions" section in "1.1. Definition of Test Conditions" on page 11.
4. For PER tests, 48 preamble symbols, 4 byte sync word, 10 byte payload and CRC-32 was used. PER and BER tested in the 450–470 MHz band.
5. Guaranteed by bench characterization.

Table 4. Receiver AC Electrical Characteristics¹ (Continued)

Parameter	Symbol	Test Condition	Min	Typ	Max	Unit
±1-Ch Offset Selectivity, 169 MHz ³	C/I _{1-CH}	Desired Ref Signal 3 dB above sensitivity, BER < 0.1%. Interferer is CW, and desired is modulated with 2.4 kbps ΔF = 1.2 kHz GFSK with BT = 0.5, RX channel BW = 4.8 kHz, channel spacing = 12.5 kHz	—	-60	—	dB
±1-Ch Offset Selectivity, 450 MHz ³	C/I _{1-CH}		—	-58	—	dB
±1-Ch Offset Selectivity, 868 / 915 MHz ³	C/I _{1-CH}		—	-53	—	dB
Blocking 1 MHz Offset ³	1M _{BLOCK}	Desired Ref Signal 3 dB above sensitivity, BER = 0.1%. Interferer is CW, and desired is modulated with 2.4 kbps, ΔF = 1.2 kHz GFSK with BT = 0.5, RX channel BW = 4.8 kHz	—	-75	—	dB
Blocking 8 MHz Offset ³	8M _{BLOCK}		—	-84	—	dB
Image Rejection ³	Im _{REJ}	No image rejection calibration. Rejection at the image frequency. IF = 468 kHz	—	35	—	dB
		With image rejection calibration in Si4362. Rejection at the image frequency. IF = 468 kHz	—	55	—	dB

Notes:

1. All specification guaranteed by production test unless otherwise noted. Production test conditions and max limits are listed in the "Production Test Conditions" section in "1.1. Definition of Test Conditions" on page 11.
2. For applications that use the major bands covered by Si4362, customers should use those parts instead of Si4362.
3. Guaranteed by qualification. BER is specified for the 450–470 MHz band. Qualification test conditions are listed in the "Qualification Test Conditions" section in "1.1. Definition of Test Conditions" on page 11.
4. For PER tests, 48 preamble symbols, 4 byte sync word, 10 byte payload and CRC-32 was used. PER and BER tested in the 450–470 MHz band.
5. Guaranteed by bench characterization.

Table 5. Auxiliary Block Specifications¹

Parameter	Symbol	Test Condition	Min	Typ	Max	Unit
Temperature Sensor Sensitivity ²	TS _S		—	4.5	—	ADC Codes/ °C
Low Battery Detector Resolution	LBD _{RES}		—	50	—	mV
Microcontroller Clock Output Frequency Range ³	F _{MC}	Configurable to Fxtal or Fxtal divided by 2, 3, 7.5, 10, 15, or 30 where Fxtal is the reference XTAL frequency. In addition, 32.768 kHz is also supported.	32.768K	—	Fxtal	Hz
Temperature Sensor Conversion ²	TEMP _{CT}	Programmable setting	—	3	—	ms
XTAL Range ⁴	XTAL _{Range}		25		32	MHz
30 MHz XTAL Start-Up Time	t _{30M}	Using XTAL and board layout in reference design. Start-up time will vary with XTAL type and board layout.	—	250	—	µs
30 MHz XTAL Cap Resolution ²	30M _{RES}		—	70	—	fF
32 kHz XTAL Start-Up Time ²	t _{32k}		—	2	—	sec
32 kHz Accuracy using Internal RC Oscillator ²	32KRC _{RES}		—	2500	—	ppm
POR Reset Time	t _{POR}		—	—	5	ms

Notes:

- All specification guaranteed by production test unless otherwise noted. Production test conditions and max limits are listed in the "Production Test Conditions" section in "1.1. Definition of Test Conditions" on page 11.
- Guaranteed by qualification. Qualification test conditions are listed in the "Qualification Test Conditions" section in "1.1. Definition of Test Conditions" on page 11.
- Microcontroller clock frequency tested in production at 1 MHz, 30 MHz and 32.768 kHz. Other frequencies tested in bench characterization.
- XTAL Range tested in production using an external clock source (similar to using a TCXO).

Table 6. Digital IO Specifications (GPIO_x, SCLK, SDO, SDI, nSEL, nIRQ, SDN)¹

Parameter	Symbol	Test Condition	Min	Typ	Max	Unit
Rise Time ^{2,3}	T _{RISE}	0.1 x V _{DD} to 0.9 x V _{DD} , C _L = 10 pF, DRV<1:0> = HH	—	2.3	—	ns
Fall Time ^{3,4}	T _{FALL}	0.9 x V _{DD} to 0.1 x V _{DD} , C _L = 10 pF, DRV<1:0> = HH	—	2	—	ns
Input Capacitance	C _{IN}		—	2	—	pF
Logic High Level Input Voltage	V _{IH}		V _{DD} x 0.7	—	—	V
Logic Low Level Input Voltage	V _{IL}		—	—	V _{DD} x 0.3	V
Input Current	I _{IN}	0 < V _{IN} < V _{DD}	-10	—	10	μA
Input Current If Pullup is Activated	I _{INP}	V _{IL} = 0 V	1	—	10	μA
Drive Strength for Output Low Level	I _{OmaxLL}	DRV[1:0] = LL ³	—	6.66	—	mA
	I _{OmaxLH}	DRV[1:0] = LH ³	—	5.03	—	mA
	I _{OmaxHL}	DRV[1:0] = HL ³	—	3.16	—	mA
	I _{OmaxHH}	DRV[1:0] = HH ³	—	1.13	—	mA
Drive Strength for Output High Level	I _{OmaxLL}	DRV[1:0] = LL ³	—	5.75	—	mA
	I _{OmaxLH}	DRV[1:0] = LH ³	—	4.37	—	mA
	I _{OmaxHL}	DRV[1:0] = HL ³	—	2.73	—	mA
	I _{OmaxHH}	DRV[1:0] = HH ³	—	0.96	—	mA
Drive Strength for Output High Level for GPIO0	I _{OmaxLL}	DRV[1:0] = LL ³	—	2.53	—	mA
	I _{OmaxLH}	DRV[1:0] = LH ³	—	2.21	—	mA
	I _{OmaxHL}	DRV[1:0] = HL ³	—	1.7	—	mA
	I _{OmaxHH}	DRV[1:0] = HH ³	—	0.80	—	mA
Logic High Level Output Voltage	V _{OH}	DRV[1:0] = HL	V _{DD} x 0.8	—	—	V
Logic Low Level Output Voltage	V _{OL}	DRV[1:0] = HL	—	—	V _{DD} x 0.2	V

Notes:

1. All specifications guaranteed by qualification. Qualification test conditions are listed in the "Qualification Test Conditions" section in "1.1. Definition of Test Conditions" on page 11.
2. 8 ns is typical for GPIO0 rise time.
3. Assuming V_{DD} = 3.3 V, drive strength is specified at V_{oh} (min) = 2.64 V and V_{ol}(max) = 0.66 V at room temperature.
4. 2.4 ns is typical for GPIO0 fall time.

Table 7. Thermal Characteristics

Parameter	Symbol	Test Condition	Value	Unit
Thermal Resistance Junction to Ambient	θ_{JA}	Still Air	30	°C/W
Junction Temperature	T_J		125	°C

Table 8. Absolute Maximum Ratings

Parameter	Value	Unit
V_{DD} to GND	-0.3, +3.6	V
Voltage on Digital Control Inputs	-0.3, $V_{DD} + 0.3$	V
Voltage on Analog Inputs	-0.3, $V_{DD} + 0.3$	V
RX Input Power	+10	dBm
Operating Ambient Temperature Range T_A	-40 to +85	°C
Thermal Impedance θ_{JA}	30	°C/W
Junction Temperature T_J	+125	°C
Storage Temperature Range T_{STG}	-55 to +125	°C

Note: Stresses beyond those listed under “Absolute Maximum Ratings” may cause permanent damage to the device. These are stress ratings only and functional operation of the device at or beyond these ratings in the operational sections of the specifications is not implied. Exposure to absolute maximum rating conditions for extended periods may affect device reliability. Caution: ESD sensitive device.

1.1. Definition of Test Conditions

Production Test Conditions:

- $T_A = +25\text{ }^\circ\text{C}$.
- $V_{DD} = +3.3\text{ VDC}$.
- External reference signal (XOUT) = 1.0 V_{PP} at 30 MHz, centered around 0.8 VDC.
- Production test schematic (unless noted otherwise).
- All RX input levels are referred to the input of a tuned balun connected to the RX input pins of the Si4362.

Qualification Test Conditions:

- $T_A = -40\text{ to }+85\text{ }^\circ\text{C}$ (Typical $T_A = 25\text{ }^\circ\text{C}$).
- $V_{DD} = +1.8\text{ to }+3.6\text{ VDC}$ (Typical $V_{DD} = 3.3\text{ VDC}$).
- Using RX reference design or production test schematic.
- All RF input and output levels referred to the pins of the Si4362 (not the RF module).

Not Recommended for New Designs

2. Functional Description

The Si4362 is a high performance, low current, wireless ISM receiver that covers major sub-GHz bands. The wide operating voltage range of 1.8–3.6 V and low current consumption make the Si4362 an ideal solution for battery powered applications. The device uses a single-conversion mixer to downconvert the 2/4-level FSK/GFSK or OOK/ASK modulated receive signal to a low IF frequency. Following a programmable gain amplifier (PGA) the signal is converted to the digital domain by a high performance $\Delta\Sigma$ ADC allowing filtering, demodulation, slicing, and packet handling to be performed in the built-in DSP increasing the receiver's performance and flexibility versus analog based architectures. The demodulated signal is output to the system MCU through a programmable GPIO or via the standard SPI bus by reading the 64-byte RX FIFO.

A single high precision local oscillator (LO) is used for receive mode. The LO is generated by an integrated VCO and $\Delta\Sigma$ Fractional-N PLL synthesizer. The synthesizer is designed to support configurable data rates from 100 bps to 1 Mbps. The Si4362 operates in the frequency bands of 142–175, 283–350, 420–525, and 850–1050 MHz with a maximum frequency accuracy step size of 28.6 Hz.

The Si4362 supports frequency hopping and antenna diversity switch control to extend the link range and improve performance. Built-in antenna diversity and support for frequency hopping can be used to further extend range and enhance performance. Antenna diversity is completely integrated into the Si4362 and can improve the system link budget by 8–10 dB, resulting in substantial range increases under adverse environmental conditions. A highly configurable packet handler allows for autonomous encoding/decoding of nearly any packet structure. Additional system features, such as an automatic wake-up timer, low battery detector, 64 byte RX FIFOs, and preamble detection, reduce overall current consumption and allows for the use of lower-cost system MCUs. An integrated temperature sensor, power-on-reset (POR), and GPIOs further reduce overall system cost and size. The Si4362 is designed to work with an MCU, crystal, and a few passive components to create a very low-cost system.

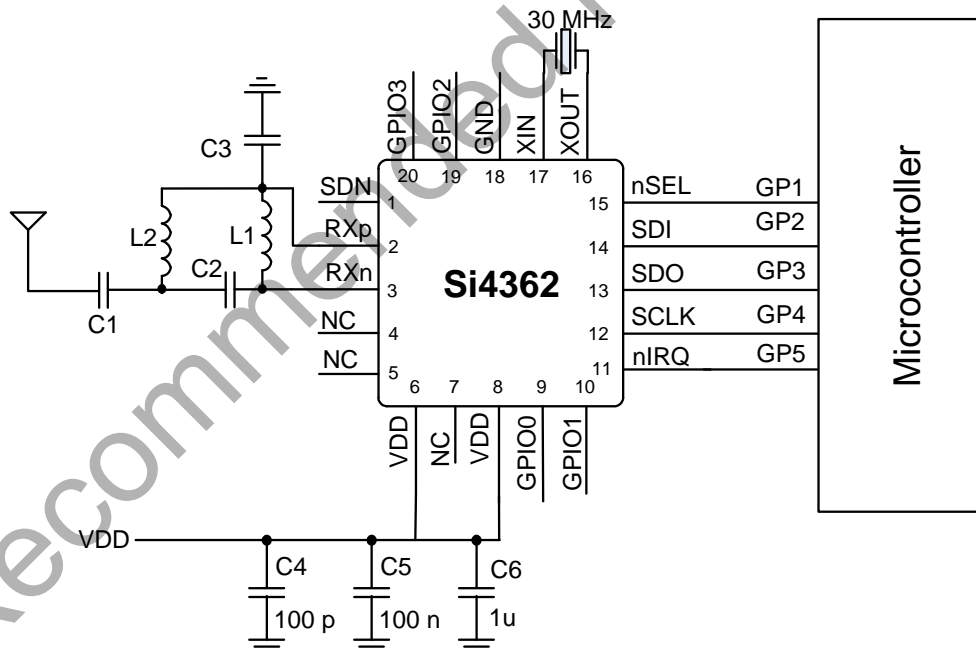

Figure 1. Si4362 Application Example

3. Controller Interface

3.1. Serial Peripheral Interface (SPI)

The Si4362 communicates with the host MCU over a standard 4-wire serial peripheral interface (SPI): SCLK, SDI, SDO, and nSEL. The SPI interface is designed to operate at a maximum of 10 MHz. The SPI timing parameters are demonstrated in Table 9. The host MCU writes data over the SDI pin and can read data from the device on the SDO output pin. Figure 2 demonstrates an SPI write command. The nSEL pin should go low to initiate the SPI command. The first byte of SDI data will be one of the firmware commands followed by n bytes of parameter data which will be variable depending on the specific command. The rising edges of SCLK should be aligned with the center of the SDI data.

Table 9. Serial Interface Timing Parameters

Symbol	Parameter	Min (ns)	Diagram
t_{CH}	Clock high time	40	<p>The diagram shows four signals: SCLK, SDI, SDO, and nSEL. SCLK is a periodic clock signal. SDI is a data bus where a 'FW Command' is followed by 'Param Byte 0' through 'Param Byte n'. SDO is an output bus that is high during the command and data transfer. nSEL is a chip select signal that goes low to initiate the command. Timing parameters are labeled: t_{SS} (select setup), t_{CL} (clock low), t_{CH} (clock high), t_{DS} (data setup), t_{DH} (data hold), t_{DD} (output data delay), t_{SH} (select hold), t_{DE} (output disable), t_{EN} (output enable), and t_{SW} (select high period).</p>
t_{CL}	Clock low time	40	
t_{DS}	Data setup time	20	
t_{DH}	Data hold time	20	
t_{DD}	Output data delay time	20	
t_{EN}	Output enable time	20	
t_{DE}	Output disable time	50	
t_{SS}	Select setup time	20	
t_{SH}	Select hold time	50	
t_{SW}	Select high period	80	

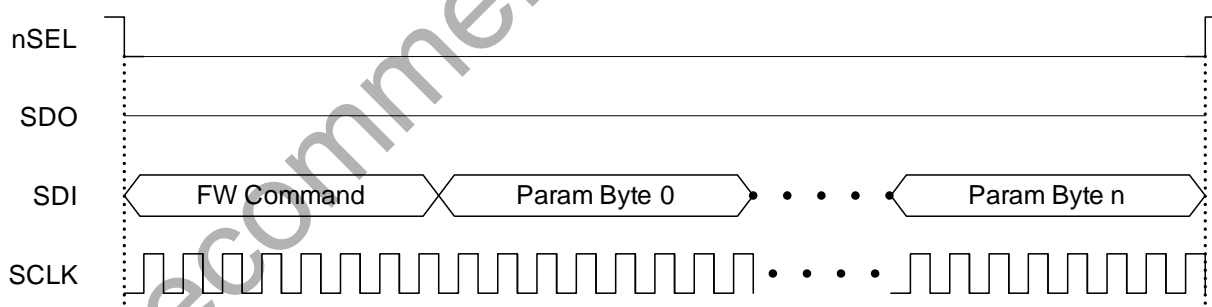

Figure 2. SPI Write Command

The Si4362 contains an internal MCU that controls all the internal functions of the radio. For SPI read commands a typical MCU flow of checking clear-to-send (CTS) is used to make sure the internal MCU has executed the command and prepared the data to be output over the SDO pin. Figure 3 demonstrates the general flow of an SPI read command. Once the CTS value reads FFh then the read data is ready to be clocked out to the host MCU. The typical time for a valid FFh CTS reading is 20 μ s. Figure 4 demonstrates the remaining read cycle after CTS is set to FFh. The internal MCU will clock out the SDO data on the negative edge so the host MCU should process the SDO data on the rising edge of SCLK.

Firmware Flow

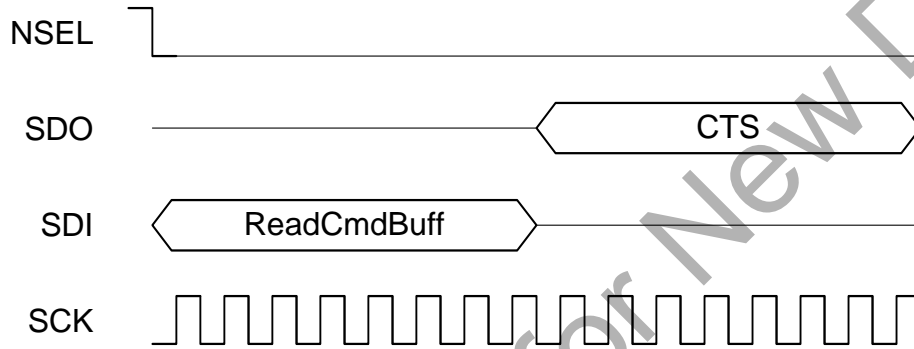
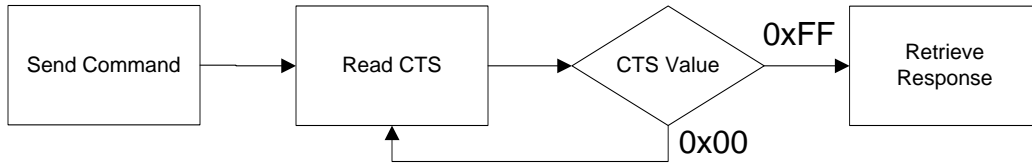

Figure 3. SPI Read Command—Check CTS Value

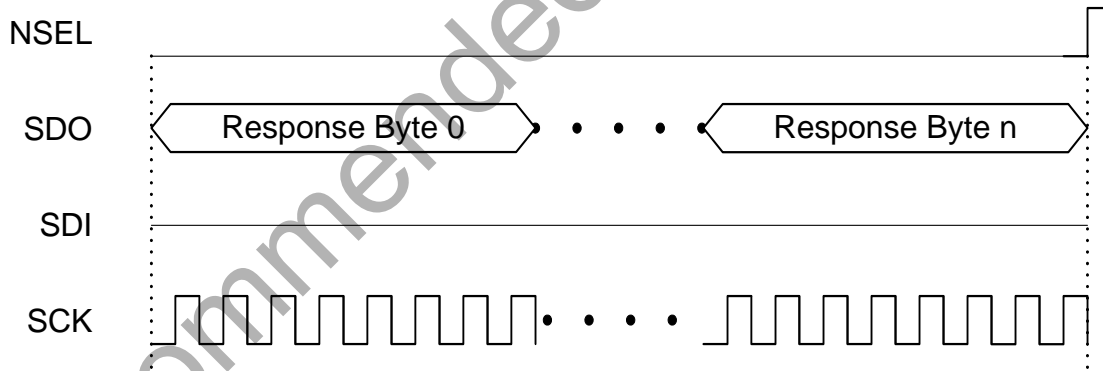

Figure 4. SPI Read Command—Clock Out Read Data

3.2. Fast Response Registers

The fast response registers are registers that can be read immediately without the requirement to monitor and check CTS. There are four fast response registers that can be programmed for a specific function. The fast response registers can be read through API commands, 0x50 for Fast Response A, 0x51 for Fast Response B, 0x53 for Fast Response C, and 0x57 for Fast Response D. The fast response registers can be configured by the "FRR_CTL_X_MODE" properties.

The fast response registers may be read in a burst fashion. After the initial 16 clock cycles, each additional eight clock cycles will clock out the contents of the next fast response register in a circular fashion. The value of the FRRs will not be updated unless NSEL is toggled.

3.3. Operating Modes and Timing

The primary states of the Si4362 are shown in Figure 5. The shutdown state completely shuts down the radio to minimize current consumption. Standby/Sleep, SPI Active, Ready, and RX tune are available to optimize the current consumption and response time to RX for a given application. API commands START_RX, and CHANGE_STATE control the operating state with the exception of shutdown which is controlled by SDN, pin 1. Table 10 shows each of the operating modes with the time required to reach RX mode as well as the current consumption of each mode. The times in Table 9 are measured from the rising edge of nSEL until the chip is in the desired state. Note that these times are indicative of state transition timing but are not guaranteed and should only be used as a reference data point. An automatic sequencer will put the chip into RX from any state. It is not necessary to manually step through the states. To simplify the diagram it is not shown but any of the lower power states can be returned to automatically after RX.

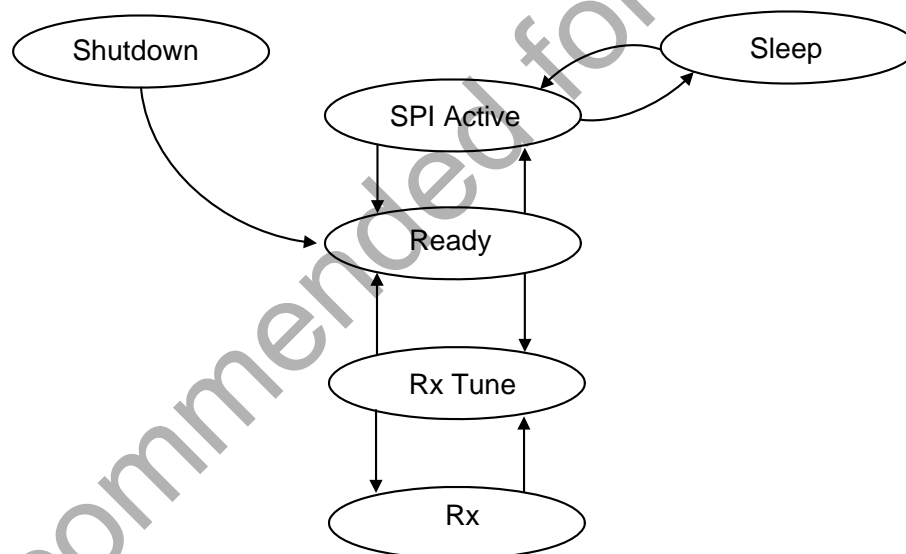

Figure 5. State Machine Diagram

Table 10. Operating State Response Time and Current Consumption*

State/Mode	Response Time to RX	Current in State/Mode
Shutdown State	15 ms	30 nA
Standby State	440 μ s	50 nA
Sleep State	440 μ s	900 nA
SPI Active State	340 μ s	1.35 mA
Ready State	122 μ s	1.8 mA
RX Tune State	74 μ s	7.2 mA
RX State	75 μ s	10 or 13 mA

Figure 6 shows the POR timing and voltage requirements. The power consumption (battery life) depends on the duty cycle of the application or how often the part is in either Rx state. In most applications the utilization of the standby state will be most advantageous for battery life but for very low duty cycle applications shutdown will have an advantage. For the fastest timing the next state can be selected in the START_RX API command to minimize SPI transactions and internal MCU processing.

3.3.1. Power on Reset (POR)

A power on reset (POR) sequence is used to boot the device up from a fully off or shutdown state. To execute this process, VDD must ramp within 1ms and must remain applied to the device for at least 10 ms. If VDD is removed, then it must stay below 0.15 V for at least 10 ms before being applied again. See Figure 6 and Table 11 for details.

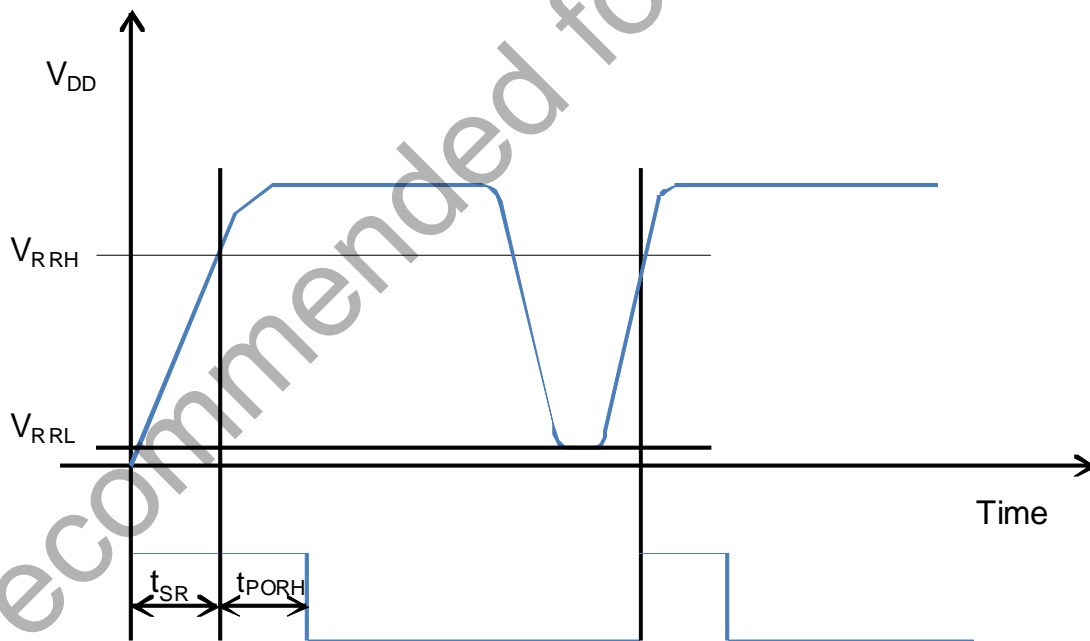

Figure 6. POR Timing Diagram

Table 11. POR Timing

Variable	Description	Min	Typ	Max	Units
t_{PORH}	High time for VDD to fully settle POR circuit.	10			ms
t_{PORL}	Low time for VDD to enable POR.	10			ms
V_{RRH}	Voltage for successful POR	$90\% \times V_{DD}$			V
V_{RRL}	Starting Voltage for successful POR	0		150	mV
t_{SR}	Slew rate of VDD for successful POR			1	ms

3.3.2. Shutdown State

The shutdown state is the lowest current consumption state of the device with nominally less than 30 nA of current consumption. The shutdown state may be entered by driving the SDN pin (Pin 1) high. The SDN pin should be held low in all states except the shutdown state. In the shutdown state, the contents of the registers are lost and there is no SPI access. When coming out of the shutdown state a power on reset (POR) will be initiated along with the internal calibrations. After the POR the POWER_UP command is required to initialize the radio. The SDN pin needs to be held high for at least 10 μ s before driving low again so that internal capacitors can discharge. Not holding the SDN high for this period of time may cause the POR to be missed and the device to boot up incorrectly. If POR timing and voltage requirements cannot be met, it is highly recommended that SDN be controlled using the host processor rather than tying it to GND on the board.

3.3.3. Standby State

Standby state has the lowest current consumption with the exception of shutdown but has much faster response time to RX mode. In most cases standby should be used as the low power state. In this state the register values are maintained with all other blocks disabled. The SPI is accessible during this mode but any SPI event, including FIFO R/W, will enable an internal boot oscillator and automatically move the part to SPI active state. After an SPI event the host will need to re-command the device back to standby through the "Change State" API command to achieve the 50 nA current consumption. If an interrupt has occurred (i.e., the nIRQ pin = 0) the interrupt registers must be read to achieve the minimum current consumption of this mode.

3.3.4. Sleep State

Sleep state is the same as standby state but the wake-up-timer and a 32 kHz clock source are enabled. The source of the 32 kHz clock can either be an internal 32 kHz RC oscillator which is periodically calibrated or a 32 kHz oscillator using an external XTAL. The SPI is accessible during this mode but an SPI event will enable an internal boot oscillator and automatically move the part to SPI active mode. After an SPI event the host will need to re-command the device back to sleep. If an interrupt has occurred (i.e., the nIRQ pin = 0) the interrupt registers must be read to achieve the minimum current consumption of this mode.

3.3.5. SPI Active State

In SPI active state the SPI and a boot up oscillator are enabled. After SPI transactions during either standby or sleep the device will not automatically return to these states. A "Change State" API command will be required to return to either the standby or sleep modes.

3.3.6. Ready State

Ready state is designed to give a fast transition time to RX state with reasonable current consumption. In this mode the Crystal oscillator remains enabled reducing the time required to switch to RX mode by eliminating the crystal start-up time.

3.3.7. RX State

The RX state may be entered from any of the other states by using the “Start RX” or “Change State” API command. A built-in sequencer takes care of all the actions required to transition between states. The following sequence of events will occur automatically to get the chip into RX mode when going from standby to RX state:

1. Enable the digital LDO and the analog LDOs.
2. Start up crystal oscillator and wait until ready (controlled by an internal timer).
3. Enable PLL.
4. Calibrate VCO
5. Wait until PLL settles to required receive frequency (controlled by an internal timer).
6. Enable receiver circuits: LNA, mixers, and ADC.
7. Enable receive mode in the digital modem.

Depending on the configuration of the radio, all or some of the following functions will be performed automatically by the digital modem: AGC, AFC (optional), update status registers, bit synchronization, packet handling (optional) including sync word, header check, and CRC. The next state after RX may be defined in the “Start RX” API command. The START_RX commands and timing will be equivalent to the timing shown in Figure 7.

3.4. Application Programming Interface (API)

An application programming interface (API), which the host MCU will communicate with, is embedded inside the device. The API is divided into two sections, commands and properties. The commands are used to control the chip and retrieve its status. The properties are general configurations which will change infrequently. The available commands and properties are described in “AN625: Si446x API Descriptions”.

3.5. Interrupts

The Si4362 is capable of generating an interrupt signal when certain events occur. The chip notifies the microcontroller that an interrupt event has occurred by setting the nIRQ output pin LOW = 0. This interrupt signal will be generated when any one (or more) of the interrupt events (corresponding to the Interrupt Status bits) occur. The nIRQ pin will remain low until the microcontroller reads the Interrupt Status Registers. The nIRQ output signal will then be reset until the next change in status is detected.

The interrupts sources are grouped into three groups: packet handler, chip status, and modem. The individual interrupts in these groups can be enabled/disabled in the interrupt property registers, 0101, 0102, and 0103. An interrupt must be enabled for it to trigger an event on the nIRQ pin. The interrupt group must be enabled as well as the individual interrupts in API property 0100.

Number	Command	Summary
0x20	GET_INT_STATUS	Returns the interrupt status—packet handler, modem, and chip
0x21	GET_PH_STATUS	Returns the packet handler status.
0x22	GET_MODEM_STATUS	Returns the modem status byte.
0x23	GET_CHIP_STATUS	Returns the chip status.

Number	Property	Default	Summary
0x0100	INT_CTL_ENABLE	0x04	Enables interrupt groups for PH, Modem, and Chip.
0x0101	INT_CTL_PH_ENABLE	0x00	Packet handler interrupt enable property.
0x0102	INT_CTL_MODEM_ENABLE	0x00	Modem interrupt enable property.
0x0103	INT_CTL_CHIP_ENABLE	0x04	Chip interrupt enable property.

Once an interrupt event occurs and the nIRQ pin is low there are two ways to read and clear the interrupts. All of the interrupts may be read and cleared in the “GET_INT_STATUS” API command. By default all interrupts will be cleared once read. If only specific interrupts want to be read in the fastest possible method the individual interrupt groups (Packet Handler, Chip Status, Modem) may be read and cleared by the “GET_MODEM_STATUS”, “GET_PH_STATUS” (packet handler), and “GET_CHIP_STATUS” API commands.

The instantaneous status of a specific function maybe read if the specific interrupt is enabled or disabled. The status results are provided after the interrupts and can be read with the same commands as the interrupts. The status bits will give the current state of the function whether the interrupt is enabled or not.

The fast response registers can also give information about the interrupt groups but reading the fast response registers will not clear the interrupt and reset the nIRQ pin.

3.6. GPIO

Four general purpose IO pins are available to utilize in the application. The GPIO are configured by the GPIO_PIN_CFG command in address 13h. For a complete list of the GPIO options please see the API guide. GPIO pins 0 and 1 should be used for active signals such as data or clock. GPIO pins 2 and 3 have more susceptibility to generating spurious in the synthesizer than pins 0 and 1. The drive strength of the GPIOs can be adjusted with the GEN_CONFIG parameter in the GPIO_PIN_CFG command. By default the drive strength is set to minimum. The default configuration for the GPIOs and the state during SDN is shown below in Table 12. The state of the IO during shutdown is also shown in Table 12. As indicated previously in Table 6, GPIO 0 has lower drive strength than the other GPIOs.

Table 12. GPIOs

Pin	SDN State	POR Default
GPIO0	0	POR
GPIO1	0	CTS
GPIO2	0	POR
GPIO3	0	POR
nIRQ	resistive VDD pull-up	nIRQ
SDO	resistive VDD pull-up	SDO
SDI	High Z	SDI

4. Modulation and Hardware Configuration Options

The Si4362 supports different modulation options and can be used in various configurations to tailor the device to any specific application or legacy system for drop in replacement. The modulation and configuration options are set in API property, MODEM_MOD_TYPE. A complete description can be found in “AN625: Si446x API Descriptions”.

4.1. Hardware Configuration Options

There are different receive demodulator options to optimize the performance and mutually-exclusive options for how the RX data is transferred from the host MCU to the RF device.

4.1.1. Receive Demodulator Options

There are multiple demodulators integrated into the device to optimize the performance for different applications, modulation formats, and packet structures. The calculator built into WDS will choose the optimal demodulator based on the input criteria.

4.1.1.1. Synchronous Demodulator

The synchronous demodulator's internal frequency error estimator acquires the frequency error based on a 101010 preamble structure. The bit clock recovery circuit locks to the incoming data stream within four transactions of a “10” or “01” bit stream. The synchronous demodulator gives optimal performance for 2- or 4-level FSK or GFSK modulation that has a modulation index less than 2.

4.1.1.2. Asynchronous Demodulator

The asynchronous demodulator should be used OOK modulation and for FSK/GFSK/4GFSK under one or more of the following conditions:

- Modulation index ≥ 2
- Non-standard preamble (not 1010101... pattern)

When the modulation index exceeds 2, the asynchronous demodulator has better sensitivity compared to the synchronous demodulator. An internal deglitch circuit provides a glitch-free data output and a data clock signal to simplify the interface to the host. There is no requirement to perform deglitching in the host MCU. The asynchronous demodulator will typically be utilized for legacy systems and will have many performance benefits over devices used in legacy designs. Unlike the Si4432/31 solution for non-standard packet structures, there is no requirement to perform deglitching on the data in the host MCU. Glitch-free data is output from the Si4362, and a sample clock for the asynchronous data can also be supplied to the host MCU; so, oversampling or bit clock recovery is not required by the host MCU. There are multiple detector options in the asynchronous demodulator block, which will be selected based upon the options entered into the WDS calculator. The asynchronous demodulator's internal frequency error estimator is able to acquire the frequency error based on any preamble structure.

4.1.2. RX Data Interface With MCU

There are two different options for transferring the data from the RF device to the host MCU. FIFO mode uses the SPI interface to transfer the data, while direct mode transfers the data in real time over GPIO.

4.1.2.1. FIFO Mode

In FIFO mode, the receive data are stored in integrated FIFO register memory. The RX FIFO is accessed by writing command 77h followed by the number of clock cycles of data the host would like to read out of the RX FIFO. The RX data will be clocked out onto the SDO pin.

In RX mode, only the bytes of the received packet structure that are considered to be “data bytes” are stored in FIFO memory. Which bytes of the received packet are considered “data bytes” is determined by the Automatic Packet Handler (if enabled) in conjunction with the Packet Handler configuration. If the Automatic Packet Handler is disabled, all bytes following the Sync word are considered data bytes and are stored in FIFO memory. Thus, even if Automatic Packet Handling operation is not desired, the preamble detection threshold and Sync word still need to be programmed so that the RX Modem knows when to start filling data into the FIFO. When the FIFO is being used in RX mode, all of the received data may still be observed directly (in realtime) by properly programming a GPIO pin as the RXDATA output pin; this can be quite useful during application development.

When in FIFO mode, the chip will automatically exit the RX State when either the PACKET_SENT or PACKET_RX interrupt occurs. The chip will return to the IDLE state programmed in the argument of the “START RX” API command, RXVALID_STATE[3:0].

4.1.2.2. Direct Mode

For legacy systems that perform packet handling within the host MCU or other baseband chip, it may not be desirable to use the FIFO. For this scenario, a Direct mode is provided, which bypasses the FIFOs entirely. In RX Direct mode, the RX Data and RX Clock can be programmed for direct (real-time) output to GPIO pins. The microcontroller may then process the RX data without using the FIFO or packet handler functions of the RFIC.

4.2. Preamble Length

The preamble length requirement is only relevant if using the synchronous demodulator. If the asynchronous demodulator is being used, then there is no requirement for a conventional 101010 pattern.

The preamble detection threshold determines the number of valid preamble bits the radio must receive to qualify a valid preamble. The preamble threshold should be adjusted depending on the nature of the application. The required preamble length threshold depends on when receive mode is entered in relation to the start of the transmitted packet and the length of the transmit preamble. With a shorter than recommended preamble detection threshold, the probability of false detection is directly related to how long the receiver operates on noise before the transmit preamble is received. False detection on noise may cause the actual packet to be missed. The preamble detection threshold may be adjusted in the modem calculator by modifying the “PM detection threshold” in the “RX parameters tab” in the radio control panel. For most applications with a preamble length longer than 32 bits, the default value of 20 is recommended for the preamble detection threshold. A shorter Preamble Detection Threshold may be chosen if occasional false detections may be tolerated. When antenna diversity is enabled, a 20-bit preamble detection threshold is recommended. When the receiver is synchronously enabled just before the start of the packet, a shorter preamble detection threshold may be used. Table 13 demonstrates the recommended preamble detection threshold and preamble length for various modes.

Table 13. Recommended Preamble Length

Mode	AFC	Antenna Diversity	Preamble Type	Recommended Preamble Length	Recommended Preamble Detection Threshold
(G)FSK	Disabled	Disabled	Standard	4 Bytes	20 bits
(G)FSK	Enabled	Disabled	Standard	5 Bytes	20 bits
(G)FSK	Disabled	Disabled	Non-standard	2 Bytes	0 bits
(G)FSK	Enabled		Non-standard	Not Supported	
(G)FSK	Disabled	Enabled	Standard	7 Bytes	24 bits
(G)FSK	Enabled	Enabled	Standard	8 Bytes	24 bits
4(G)FSK	Disabled	Disabled	Standard	40 symbols	16 symbols

Notes:

1. The recommended preamble length and preamble detection thresholds listed above are to achieve 0% PER. They may be shortened when occasional packet errors are tolerable.
2. All recommended preamble lengths and detection thresholds include AGC and BCR settling times.
3. “Standard” preamble type should be set for an alternating data sequence at the max data rate (...10101010...)
4. “Non-standard” preamble type can be set for any preamble type including ...10101010...
5. When preamble detection threshold = 0, sync word needs to be 3 Bytes to avoid false syncs. When only a 2 Byte sync word is available the sync word detection can be extended by including the last preamble Byte into the RX sync word setting.

Table 13. Recommended Preamble Length (Continued)

Mode	AFC	Antenna Diversity	Preamble Type	Recommended Preamble Length	Recommended Preamble Detection Threshold
4(G)FSK	Enabled	Disabled	Standard	48 symbols	16 symbols
4(G)FSK			Non-standard	Not Supported	
OOK	Disabled	Disabled	Standard	4 Bytes	20 bits
OOK	Disabled	Disabled	Non-standard	2 Bytes	0 bits
OOK	Enabled			Not Supported	

Notes:

1. The recommended preamble length and preamble detection thresholds listed above are to achieve 0% PER. They may be shortened when occasional packet errors are tolerable.
2. All recommended preamble lengths and detection thresholds include AGC and BCR settling times.
3. "Standard" preamble type should be set for an alternating data sequence at the max data rate (...10101010...)
4. "Non-standard" preamble type can be set for any preamble type including ...10101010...
5. When preamble detection threshold = 0, sync word needs to be 3 Bytes to avoid false syncs. When only a 2 Byte sync word is available the sync word detection can be extended by including the last preamble Byte into the RX sync word setting.

5. Internal Functional Blocks

The following sections provide an overview to the key internal blocks and features.

5.1. RX Chain

The internal low-noise amplifier (LNA) is designed to be a wide-band LNA that can be matched with three external discrete components to cover any common range of frequencies in the sub-GHz band. The LNA has extremely low noise to suppress the noise of the following stages and achieve optimal sensitivity; so, no external gain or front-end modules are necessary. The LNA has gain control, which is controlled by the internal automatic gain control (AGC) algorithm. The LNA is followed by an I-Q mixer, filter, programmable gain amplifier (PGA), and ADC. The I-Q mixers downconvert the signal to an intermediate frequency. The PGA then boosts the gain to be within dynamic range of the ADC. The ADC rejects out-of-band blockers and converts the signal to the digital domain where filtering, demodulation, and processing is performed. Peak detectors are integrated at the output of the LNA and PGA for use in the AGC algorithm.

5.1.1. RX Chain Architecture

It is possible to operate the RX chain in different architecture configurations: fixed-IF, zero-IF, scaled-IF, and modulated IF. There are trade-offs between the architectures in terms of sensitivity, selectivity, and image rejection. Fixed-IF is the default configuration and is recommended for most applications. With 35 dB native image rejection and autonomous image calibration to achieve 55 dB, the fixed-IF solution gives the best performance for most applications. Fixed-IF obtains the best sensitivity, but it has the effect of degraded selectivity at the image frequency. An autonomous image rejection calibration is included in the Si4362 and described in more detail in "5.2.3. Image Rejection and Calibration" on page 26. For fixed-IF and zero-IF, the sensitivity is degraded for data rates less than 100 kbps or bandwidths less than 200 kHz. The reduction in sensitivity is caused by increased flicker noise as dc is approached. The benefit of zero-IF is that there is no image frequency; so, there is no degradation in the selectivity curve, but it has the worst sensitivity. Modulated IF is useful for OOK if image elimination is required similar to Zero-IF. Scaled-IF is a trade-off between fixed-IF and zero-IF. In the scaled-IF architecture, the image frequency is placed or hidden in the adjacent channel where it only slightly degrades the typical adjacent channel selectivity. The scaled-IF approach has better sensitivity than zero-IF but still some degradation in selectivity due to the image. In scaled-IF mode, the image frequency is directly proportional to the channel bandwidth selected. Figure 7 demonstrates the trade-off in sensitivity between the different architecture options.

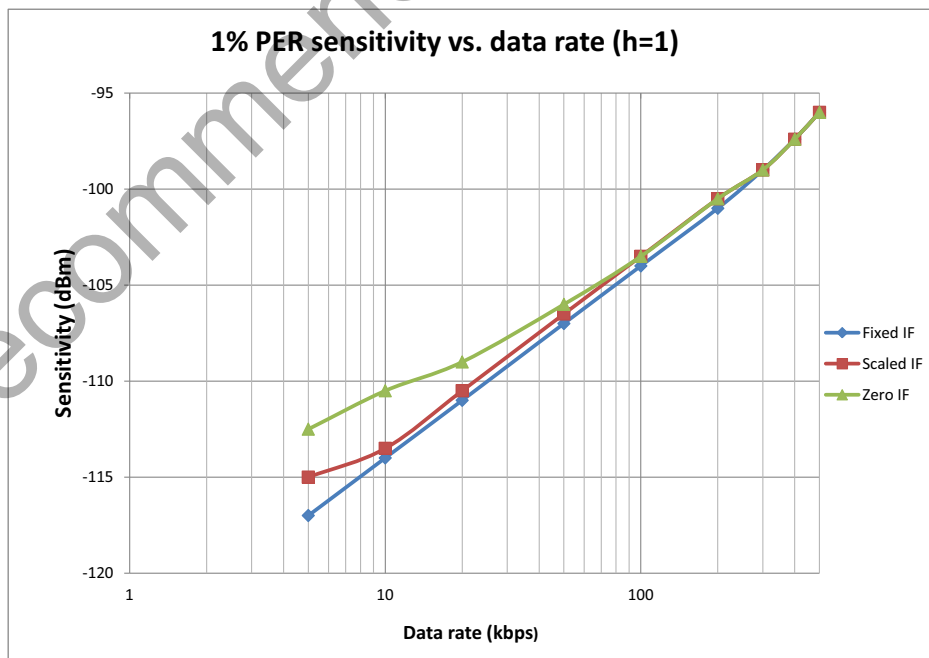

Figure 7. RX Architecture vs. Data Rate

5.2. RX Modem

Using high-performance ADCs allows channel filtering, image rejection, and demodulation to be performed in the digital domain, which allows for flexibility in optimizing the device for particular applications. The digital modem performs the following functions:

- Channel selection filter
- RX demodulation
- Automatic Gain Control (AGC)
- Preamble detection
- Invalid preamble detection
- Radio signal strength indicator (RSSI)
- Automatic frequency compensation (AFC)
- Image Rejection Calibration
- Packet handling including EZMAC[®] features
- Cyclic redundancy check (CRC)

The digital channel filter and demodulator are optimized for ultra-low-power consumption and are highly configurable. Supported modulation types are GFSK, FSK, 4GFSK, 4FSK, GMSK, ASK, and OOK. The channel filter can be configured to support bandwidths ranging from 850 down to 1.1 kHz. A large variety of data rates are supported ranging from 100 bps up to 1 Mbps. The configurable preamble detector is used with the synchronous demodulator to improve the reliability of the sync-word detection. Preamble detection can be skipped using only sync detection, which is a valuable feature of the asynchronous demodulator when very short preambles are used in protocols, such as MBus. The received signal strength indicator (RSSI) provides a measure of the signal strength received on the tuned channel. The resolution of the RSSI is 0.5 dB. This high-resolution RSSI enables accurate channel power measurements for clear channel assessment (CCA), carrier sense (CS), and listen before talk (LBT) functionality. A comprehensive programmable packet handler including key features of Silicon Labs' EZMAC is integrated to create a variety of communication topologies ranging from peer-to-peer networks to mesh networks. The extensive programmability of the packet header allows for advanced packet filtering, which, in turn enables a mix of broadcast, group, and point-to-point communication. A wireless communication channel can be corrupted by noise and interference, so it is important to know if the received data is free of errors. A cyclic redundancy check (CRC) is used to detect the presence of erroneous bits in each packet. A CRC is computed and appended at the end of each transmitted packet and verified by the receiver to confirm that no errors have occurred. The packet handler and CRC can significantly reduce the load on the system microcontroller allowing for a simpler and cheaper microcontroller.

5.2.1. Automatic Gain Control (AGC)

The AGC algorithm is implemented digitally using an advanced control loop optimized for fast response time. The AGC occurs within a single bit or in less than 2 μ s. Peak detectors at the output of the LNA and PGA allow for optimal adjustment of the LNA gain and PGA gain to optimize IM3, selectivity, and sensitivity performance.

5.2.2. Auto Frequency Correction (AFC)

Frequency mistuning caused by crystal inaccuracies can be compensated for by enabling the digital automatic frequency control (AFC) in receive mode. There are two types of integrated frequency compensation: modem frequency compensation, and AFC by adjusting the PLL frequency. With AFC disabled, the modem compensation can correct for frequency offsets up to ± 0.25 times the IF bandwidth. When the AFC is enabled, the received signal will be centered in the pass-band of the IF filter, providing optimal sensitivity and selectivity over a wider range of frequency offsets up to ± 0.35 times the IF bandwidth. When AFC is enabled, the preamble length needs to be long enough to settle the AFC. As shown in Table 13 on page 22, an additional byte of preamble is typically required to settle the AFC.

5.2.3. Image Rejection and Calibration

Since the receiver utilizes a low-IF architecture, the selectivity will be affected by the image frequency. The IF frequency is 468.75 kHz (Fxtal/64), and the image frequency will be at 937.5 kHz below the RF frequency. The native image rejection of the Si4362 is 35 dB. Image rejection calibration is available in the Si4362 to improve the image rejection to more than 55 dB. The calibration is initiated with the IRCAL API command. The calibration uses an internal signal source, so no external signal generator is required. The initial calibration takes 250 ms, and periodic re-calibration takes 100 ms. Re-calibration should be initiated when the temperature has changed more than 30 °C.

For high-band (868/915M), the following commands should be used for image calibration:

- IRCAL 56 10 FA F0—course calibration (150 ms)
- IRCAL 13 10 FA F0—fine calibration (100 ms)

For low-band (430–510 MHz) the following commands should be used for image calibration:

- IRCAL 56 10 CA F0—course calibration (150 ms)
- IRCAL 13 10 CA F0—fine calibration (100 ms)

5.2.4. Received Signal Strength Indicator

The received signal strength indicator (RSSI) is an estimate of the signal strength in the channel to which the receiver is tuned. The RSSI measurement is done after the channel filter, so it is only a measurement of the desired or undesired in-band signal power. There are two different locations for reading the RSSI value and different options for configuring the RSSI value. The fastest method for reading the RSSI is to configure one of the four fast response registers for a latched RSSI value. The fast response registers can be read in 16 SPI clock cycles with no requirement to wait for CTS. The RSSI value may also be read out of the GET_MODEM_STATUS command. In this command, both the current RSSI and the latched RSSI are available. Reading the RSSI in the GET_MODEM_STATUS command takes longer than reading the RSSI out of the fast response register. After the initial command, it will take 33 μs for CTS to be set and then the four or five bytes of SPI clock cycles to read out the respective current or latched RSSI values.

The RSSI configuration options are set in the MODEM_RSSI_CONTROL API property. The RSSI values may be latched and stored based on the following events: preamble detection, sync detection, or four bit times measured after the start of RX mode. The requirement for four bit times is determined by the delay and settling through the modem and digital channel filter. In MODEM_RSSI_CONTROL, the RSSI may be defined to update every bit or averaged and updated every four bits. If RSSI averaging over four bits is enabled, the latched RSSI value after the start of RX mode will be seven bits to allow for the averaging. The latched RSSI values are cleared when entering RX mode so they may be read after the packet is received or after dropping back to standby mode. If the RSSI value have been cleared by the start of RX but not latched yet, a 0 value will be read if it is attempted to be read.

The RSSI value read by the API could be translated to dBm by the following linear equation:

$$\text{RSSI(in dBm)} = (\text{RSSI_value} / 2) - \text{RSSIcal}$$

RSSIcal in the formula depends on the matching network, modem settings and external LNA gain (if present). The RSSIcal value can be obtained by a simple calibration with a signal generator connected at the antenna input. Without external LNA, the value of RSSIcal is around 130 ±30.

During the reception of a packet, it may be useful to detect if a secondary interfering signal (desired or undesired) arrives. To detect this event, a feature for RSSI jump detection is available. While receiving a packet, if the RSSI changes by a programmed amount, an interrupt or GPIO can be configured to notify the host. The level of RSSI increase (jump) is programmable through the MODEM_RSSI_JUMP_THRESH API property. If an RSSI jump is detected, the modem may be programmed to automatically reset so that it may lock onto the new stronger signal. The packet handler cannot be automatically reset by this feature. If this feature is being used in conjunction with the packet handler, the host will need to manually reset the receiver to reset the packet handler. The configuration and options for RSSI jump detection are programmed in the MODEM_RSSI_CONTROL2 API property. By default, RSSI jump detection is not enabled.

The RSSI values and curves may be offset by the MODEM_RSSI_COMP API property. The default value of 7'h32 corresponds to no RSSI offset. Setting a value less than 7'h32 corresponds to a negative offset, and a value higher than 7'h32 corresponds to a positive offset. The offset value is in 1 dB steps. For example, setting a value of 7'h3A would correspond to a positive offset of 8 dB.

Clear channel assessment (CCA) or RSSI threshold detection is also available. An RSSI threshold may be set in the MODEM_RSSI_THRESH API property. If the RSSI value is above this threshold, an interrupt or GPIO may notify the host. Both the latched version and asynchronous version of this threshold are available on any of the GPIOs. Automatic fast hopping based on RSSI is available. See “5.3.1.2. Automatic RX Hopping and Hop Table”.

5.3. Synthesizer

An integrated Sigma Delta ($\Sigma\Delta$) Fractional-N PLL synthesizer capable of operating over the bands from 142–175, 283–350, 420–525, and 850–1050 MHz for the Si4362. Using a $\Sigma\Delta$ synthesizer has many advantages; it provides flexibility in choosing data rate, deviation, channel frequency, and channel spacing. The nominal reference frequency to the PLL is 30 MHz, but any XTAL frequency from 25 to 32 MHz may be used. The modem configuration calculator in WDS will automatically account for the XTAL frequency being used. The PLL utilizes a differential LC VCO with integrated on-chip inductors. The output of the VCO is followed by a configurable divider, which will divide the signal down to the desired output frequency band.

5.3.1. Synthesizer Frequency Control

The frequency is set by changing the integer and fractional settings to the synthesizer. The WDS calculator will automatically provide these settings, but the synthesizer equation is shown below for convenience. The APIs for setting the frequency are `FREQ_CONTROL_INTE`, `FREQ_CONTROL_FRAC2`, `FREQ_CONTROL_FRAC1`, and `FREQ_CONTROL_FRAC0`.

$$\text{RF_channel} = \left(\text{fc_inte} + \frac{\text{fc_frac}}{2^{19}} \right) \times \frac{2 \times \text{freq_xo}}{\text{outdiv}} (\text{Hz})$$

Note: The $\text{fc_frac}/2^{19}$ value in the above formula has to be a number between 1 and 2.

Table 14. Output Divider (Outdiv) Values for the Si4362

Outdiv	Lower (MHz)	Upper (MHz)
24	142	175
12	284	350
8	420	525
4	850	1050

5.3.1.1. EZ Frequency Programming

In applications that utilize multiple frequencies or channels, it may not be desirable to write four API registers each time a frequency change is required. EZ frequency programming is provided so that only a single register write (channel number) is required to change frequency. A base frequency is first set by first programming the integer and fractional components of the synthesizer. This base frequency will correspond to channel 0. Next, a channel step size is programmed into the `FREQ_CONTROL_CHANNEL_STEP_SIZE_1` and `FREQ_CONTROL_CHANNEL_STEP_SIZE_0` API registers. The resulting frequency will be:

$$\text{RF Frequency} = \text{Base Frequency} + \text{Channel} \times \text{Stepsize}$$

The second argument of the `START_RX` is `CHANNEL`, which sets the channel number for EZ frequency programming. For example, if the channel step size is set to 1 MHz, the base frequency is set to 900 MHz with the `INTE` and `FRAC` API registers, and a `CHANNEL` number of 5 is programmed during the `START_RX` command, the resulting frequency will be 905 MHz. If no `CHANNEL` argument is written as part of the `START_RX` command, it will default to the previous value. The initial value of `CHANNEL` is 0; so, if no `CHANNEL` value is written, it will result in the programmed base frequency.

5.3.1.2. Automatic RX Hopping and Hop Table

The transceiver supports an automatic hopping feature that can be fully configured through the API. This is intended for RX hopping where the device has to hop from channel to channel and look for packets. Once the device is put into the RX state, it automatically starts hopping through the hop table if the feature is enabled.

The hop table can hold up to 64 entries and is maintained in firmware. Each entry is a channel number; so, the hop table can hold up to 64 channels. The number of entries in the table is set by RX HOP TABLE_SIZE API. The specified channels correspond to the EZ frequency programming method for programming the frequency. The receiver starts at the base channel and hops in sequence from the top of the hop table to the bottom. The table will wrap around to the base channel once it reaches the end of the table. An entry of 0xFF in the table indicates that the entry should be skipped. The device will hop to the next non 0xFF entry.

There are three conditions that can be used to determine whether to continue hopping or to stay on a particular channel. These conditions are:

- RSSI threshold
- Preamble timeout (invalid preamble pattern)
- Sync word timeout (invalid or no sync word detected after preamble)

These conditions can be used individually, or they can be enabled all together by configuring the RX_HOP_CONTROL API. However, the firmware will make a decision on whether or not to hop based on the first condition that is met.

The RSSI that is monitored is the current RSSI value. This is compared to the threshold, and, if it is above the threshold value, it will stay on the channel. If the RSSI is below the threshold, it will continue hopping. There is no averaging of RSSI done during the automatic hopping from channel to channel. Since the preamble timeout and the sync word timeout are features that require packet handling, the RSSI threshold is the only condition that can be used if the user is in “direct” or “RAW” mode where packet handling features are not used.

Note that the RSSI threshold is not an absolute RSSI value; instead, it is a relative value and should be verified on the bench to find an optimal threshold for the application.

The turnaround time from RX to RX on a different channel using this method is 115 μ s. The time spent in receive mode will be determined by the configuration of the hop conditions. Manual RX hopping will have the fastest turn-around time but will require more overhead and management by the host MCU.

The following are example steps for using Auto Hop:

1. Set the base frequency (inte + frac) and channel step size.
2. Define the number of entries in the hop table (RX_HOP_TABLE_SIZE).
3. Write the channels to the hop table (RX_HOP_TABLE_ENTRY_n)
4. Configure the hop condition and enable auto hopping- RSSI, preamble, or sync (RX_HOP_CONTROL).
5. Set preamble and sync parameters if enabled.
6. Program the RSSI threshold property in the modem using “MODEM_RSSI_THRESH”.
7. Set the preamble threshold using “PREAMBLE_CONFIG_STD_1”.
8. Program the preamble timeout property using “PREAMBLE_CONFIG_STD_2”.
9. Set the sync detection parameters if enabled.
10. If needed, use “GPIO_PIN_CFG” to configure a GPIO to toggle on hop and hop table wrap.
11. Use the “START_RX” API with channel number set to the first valid entry in the hop table (i.e., the first non 0xFF entry).
12. Device should now be in auto hop mode.

5.3.1.3. Manual RX Hopping

The RX_HOP command provides the fastest method for hopping from RX to RX but it requires more overhead and management by the host MCU. Using the RX_HOP command, the turn-around time is 75 μ s. The timing is faster with this method than Start_RX or RX hopping because one of the calculations required for the synthesizer calibrations is offloaded to the host and must be calculated/stored by the host, VCO_CNT0. For information about using fast manual hopping, contact customer support.

5.4. Crystal Oscillator

The Si4362 includes an integrated crystal oscillator with a fast start-up time of less than 250 μ s. The design is differential with the required crystal load capacitance integrated on-chip to minimize the number of external components. By default, all that is required off-chip is the crystal. The default crystal is 30 MHz, but the circuit is designed to handle any XTAL from 25 to 32 MHz. If a crystal different than 30 MHz is used, the POWER_UP API boot command must be modified. The WDS calculator crystal frequency field must also be changed to reflect the frequency being used. The crystal load capacitance can be digitally programmed to accommodate crystals with various load capacitance requirements and to adjust the frequency of the crystal oscillator. The tuning of the crystal load capacitance is programmed through the GLOBAL_XO_TUNE API property. The total internal capacitance is 11 pF and is adjustable in 127 steps (70 fF/step). The crystal frequency adjustment can be used to compensate for crystal production tolerances. The frequency offset characteristics of the capacitor bank are demonstrated in Figure 8.

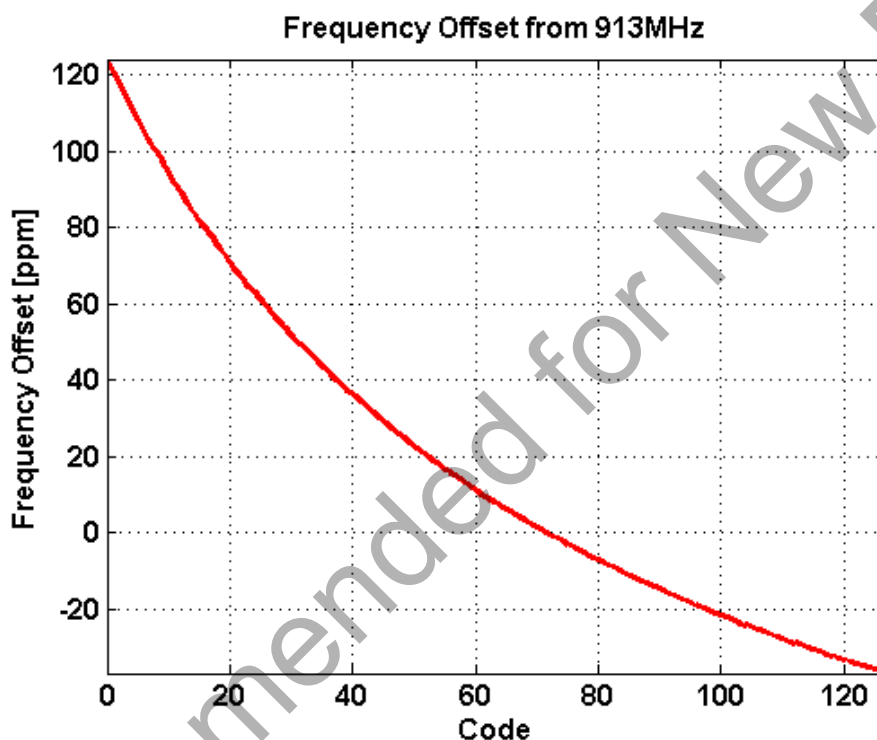

Figure 8. Capacitor Bank Frequency Offset Characteristics

Utilizing the on-chip temperature sensor and suitable control software, the temperature dependency of the crystal can be canceled.

A TCXO or external signal source can easily be used in place of a conventional XTAL and should be connected to the XIN pin. It is recommended that the incoming clock signal have a peak-to-peak swing in the range of 600 mV to 1.4 V and ac-coupled to the XIN pin. If the peak-to-peak swing of the TCXO exceeds 1.4 V peak-to-peak, then dc coupling to the XIN pin should be used. The maximum allowed swing on XIN is 1.8 V peak-to-peak. The XO capacitor bank should be set to 0 whenever an external drive is used on the XIN pin. In addition, the POWER_UP command should be invoked with the TCXO option whenever the external drive is used.

6. Data Handling and Packet Handler

6.1. RX FIFOs

A 64-byte FIFOs is integrated into the chip as shown in Figure 9. Reading from command Register 77h reads data from the RX FIFO. The RX FIFO has one programmable threshold, which is programmed by setting the "RX_FIFO_FULL" property. When the incoming RX data crosses the Almost Full Threshold, an interrupt will be generated to the microcontroller via the nIRQ pin. The microcontroller will then need to read the data from the RX FIFO. The RX Almost Full Threshold indication implies that the host can read at least the threshold number of bytes from the RX FIFO at that time. The RX FIFO may be cleared or reset with the "FIFO_RESET" command.

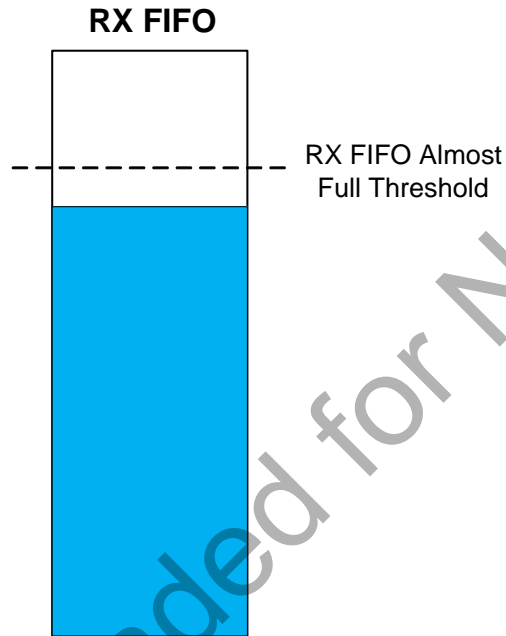

Figure 9. RX FIFO

6.2. Packet Handler

When using the FIFOs, automatic packet handling may be enabled for RX mode. The usual fields for network communication, such as preamble, synchronization word, headers, packet length, and CRC, can be configured to be automatically added to the data payload. Automatically adding these fields to the data payload and automatically checking them in RX mode greatly reduces the amount of communication between the microcontroller and the Si4362. It also greatly reduces the required computational power of the microcontroller. The general packet structure is shown in Figure 10. Any or all of the fields can be enabled and checked by the internal packet handler.

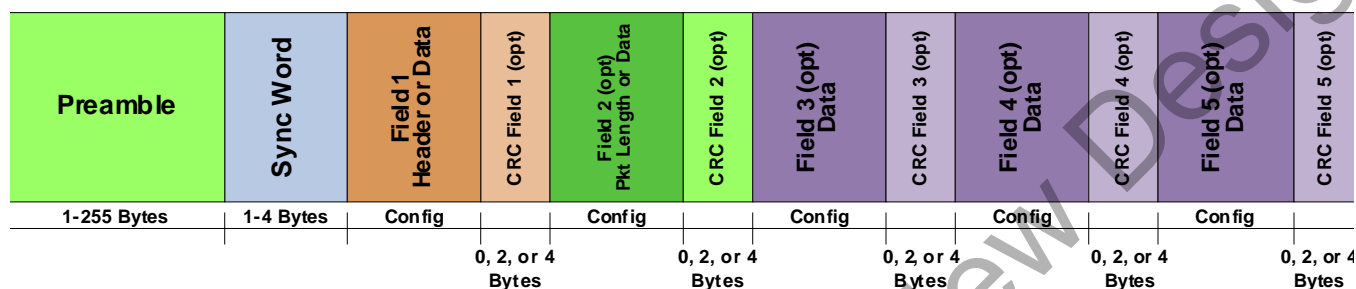

Figure 10. Packet Handler Structure

The fields are highly programmable and can be used to check any kind of pattern in a packet structure. The general functions of the packet handler include the following:

- Detection/validation of Preamble quality in RX mode (PREAMBLE_VALID signal)
- Detection of Sync word in RX mode (SYNC_OK signal)
- Detection of valid packets in RX mode (PKT_VALID signal)
- Detection of CRC errors in RX mode (CRC_ERR signal)
- Data de-whitening and/or Manchester decoding (if enabled) in RX mode
- Match/Header checking in RX mode
- Storage of Data Field bytes into FIFO memory in RX mode

For details on how to configure the packet handler, see “AN626: Packet Handler Operation for Si446x RFICs”.

7. RX Modem Configuration

The Si4362 can easily be configured for different data rate, deviation, frequency, etc. by using the WDS settings calculator, which generates an initialization file for use by the host MCU.

8. Auxiliary Blocks

8.1. Wake-up Timer and 32 kHz Clock Source

The chip contains an integrated wake-up timer that can be used to periodically wake the chip from sleep mode. The wake-up timer runs from either the internal 32 kHz RC Oscillator, or from an external 32 kHz XTAL.

The wake-up timer can be configured to run when in sleep mode. If WUT_EN = 1 in the GLOBAL_WUT_CONFIG property, prior to entering sleep mode, the wake-up timer will count for a time specified defined by the GLOBAL_WUT_R and GLOBAL_WUT_M properties. At the expiration of this period, an interrupt will be generated on the nIRQ pin if this interrupt is enabled in the INT_CTL_CHIP_ENABLE property. The microcontroller will then need to verify the interrupt by reading the chip interrupt status either via GET_INT_STATUS or a fast response register. The formula for calculating the Wake-Up Period is as follows:

$$WUT = WUT_M \times \frac{4 \times 2^{WUT_R}}{32,768} [\text{ms}]$$

The RC oscillator frequency will change with temperature; so, a periodic recalibration is required. The RC oscillator is automatically calibrated during the POWER_UP command and exits from the Shutdown state. To enable the recalibration feature, CAL_EN must be set in the GLOBAL_WUT_CONFIG property, and the desired calibration period should be selected via WUT_CAL_PERIOD[2:0] in the same API property. During the calibration, the 32 kHz RC oscillator frequency is compared to the 30 MHz XTAL and then adjusted accordingly. The calibration needs to start the 30 MHz XTAL, which increases the average current consumption; so, a longer CAL_PERIOD results in a lower average current consumption. The 32 kHz XTAL accuracy is comprised of both the XTAL parameters and the internal circuit. The XTAL accuracy can be defined as the XTAL initial error + XTAL aging + XTAL temperature drift + detuning from the internal oscillator circuit. The error caused by the internal circuit is typically less than 10 ppm.

Table 15. WUT Specific Commands and Properties

API Properties	Description	Requirements/Notes
GLOBAL_WUT_CONFIG	GLOBAL WUT configuration	WUT_EN—Enable/disable wake up timer. WUT_LBD_EN—Enable/disable low battery detect measurement on WUT interval. WUT_LDC_EN: 0 = Disable low duty cycle operation. 1 = RX LDC operation treated as wake up START_RX WUT state is used CAL_EN—Enable calibration of the 32 kHz RC oscillator WUT_CAL_PERIOD[2:0]—Sets calibration period.
GLOBAL_WUT_M_15_8	Sets HW WUT_M[15:8]	WUT_M—Parameter to set the actual wakeup time. See equation above.
GLOBAL_WUT_M_7_0	Sets HW WUT_M[7:0]	WUT_M—Parameter to set the actual wakeup time. See equation above.
GLOBAL_WUT_R	Sets WUT_R[4:0] Sets WUT_SLEEP to choose WUT state	WUT_R—Parameter to set the actual wakeup time. See equation above. WUT_SLEEP: 0 = Go to ready state after WUT 1 = Go to sleep state after WUT
GLOBAL_WUT_LDC	Sets FW internal WUT_LDC	WUT_LDC—Parameter to set the actual wakeup time. See equation in "8.2. Low Duty Cycle Mode (Auto RX Wake-Up)" on page 34.

Table 16. WUT Related API Commands and Properties

Command/Property	Description	Requirements/Notes
WUT Interrupt Enable		
INT_CTL_ENABLE	Interrupt enable property	CHIP_INT_STATUS_EN—Enables chip status interrupt.
INT_CTL_CHIP_ENABLE	Chip interrupt enable property	WUT_EN—Enables WUT interrupt.
32 kHz Clock Source Selection		
GLOBAL_CLK_CFG	Clock configuration options	CLK_32K_SEL[2:0]—Configuring the source of WUT.
WUT Interrupt Output		
GPIO_PIN_CFG	Host can enable interrupt on WUT expire	GPIOx_MODE[5:0] = 14 and NIRQ_MODE[5:0] = 39.
RX Operation		
START_RX	START RX when wake up timer expire	START = 1.

8.2. Low Duty Cycle Mode (Auto RX Wake-Up)

The low duty cycle (LDC) mode is implemented to automatically wake-up the receiver to check if a valid signal is available. It allows low average current polling operation by the Si4362 for which the wake-up timer (WUT) is used. RX LDC operation must be set via the GLOBAL_WUT_CONFIG property when setting up the WUT. The LDC wake-up period is determined by the following formula:

$$LDC = WUT_LDC \times \frac{4 \times 2^{WUT_R}}{32,768} [\text{ms}]$$

where the WUT_LDC parameter can be set by the GLOBAL_WUT_LDC property. The WUT period must be set in conjunction with the LDC mode duration; for the relevant API properties, see the wake-up timer (WUT) section.

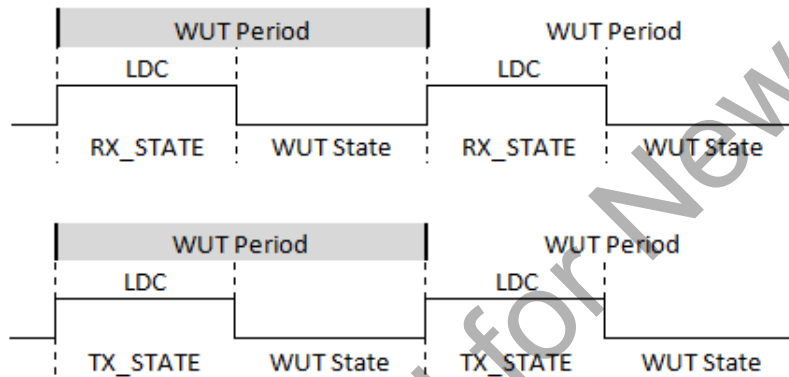

Figure 11. RX LDC Sequences

The basic operation of RX LDC mode is shown in Figure 12. The receiver periodically wakes itself up to work on RX_STATE during LDC mode duration. If a valid preamble is not detected, a receive error is detected, or an entire packet is not received, the receiver returns to the WUT state (i.e., ready or sleep) at the end of LDC mode duration and remains in that mode until the beginning of the next wake-up period. If a valid preamble or sync word is detected, the receiver delays the LDC mode duration to receive the entire packet. If a packet is not received during two LDC mode durations, the receiver returns to the WUT state at the last LDC mode duration until the beginning of the next wake-up period.

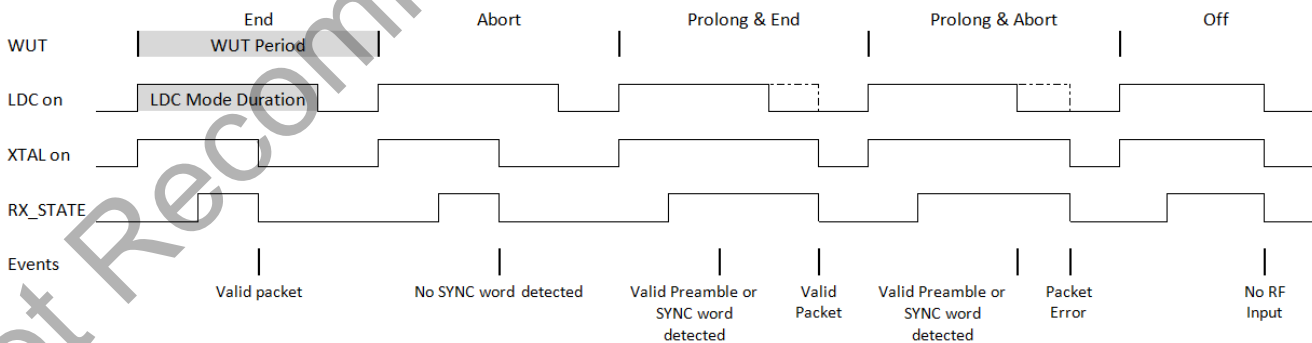

Figure 12. Low Duty Cycle Mode for RX

8.3. Temperature, Battery Voltage, and Auxiliary ADC

The Si4362 contains an integrated auxiliary ADC for measuring internal battery voltage, an internal temperature sensor, or an external component over a GPIO. The ADC utilizes a SAR architecture and achieves 11-bit resolution. The Effective Number of Bits (ENOB) is 9 bits. When measuring external components, the input voltage range is 1 V, and the conversion rate is between 300 Hz to 2.44 kHz. The ADC value is read by first sending the GET_ADC_READING command and enabling the inputs that are desired to be read: GPIO, battery, or temp. The temperature sensor accuracy at 25 °C is typically ± 2 °C.

■ Command Stream

GET_ADC_READING Command	7	6	5	4	3	2	1	0
CMD	0x14							
ADC_EN	0	0	0	TEMPERATURE_EN	BATTERY_VOLTAGE_EN	ADC_GPIO_EN	ADC_GPIO_PIN[1:0]	
ADC_CFG				UDTIME[3:0]	GPIO_ATT[3:0]			

■ Reply Stream

GET_ADC_READING Reply	7	6	5	4	3	2	1	0
CTS	CTS[7:0]							
GPIO_ADC	GPIO_ADC[15:8]							
GPIO_ADC	GPIO_ADC[7:0]							
BATTERY_ADC	BATTERY_ADC[15:8]							
BATTERY_ADC	BATTERY_ADC[7:0]							
TEMP_ADC	TEMP_ADC[15:8]							
TEMP_ADC	TEMP_ADC[7:0]							
RESERVED	Reserved							
RESERVED	Reserved							

■ Parameters

- TEMPERATURE_EN
 - 0 = Do not perform ADC conversion of temperature. This will read 0 value in reply TEMPERATURE.
 - 1 = Perform ADC conversion of temperature. This results in TEMP_ADC.
Temp (°C) = TEMP_ADC[15:0] x 568/2560 – 297
- BATTERY_VOLTAGE_EN
 - 0 = Don't do ADC conversion of battery voltage, will read 0 value in reply BATTERY_ADC
 - 1 = Do ADC conversion of battery voltage, results in BATTERY_ADC. $V_{batt} = 3 * BATTERY_ADC / 1280$
- ADC_GPIO_EN
 - 0 = Don't do ADC conversion on GPIO, will read 0 value in reply
 - 1 = Do ADC conversion of GPIO, results in GPIO_ADC. $V_{gpio} = GPIO_ADC / GPIO_ADC_DIV$ where GPIO_ADC_DIV is defined by GPIO_ATT selection.
- ADC_GPIO_PIN[1:0] - Select GPIOx pin. The pin must be set as input.
 - 0 = Measure voltage of GPIO0
 - 1 = Measure voltage of GPIO1
 - 2 = Measure voltage of GPIO2
 - 3 = Measure voltage of GPIO3

- UDTIME[7:4] - ADC conversion Time = $\text{SYS_CLK} / 12 / 2^{(\text{UDTIME} + 1)}$. Defaults to 0xC if ADC_CFG is 0. Selecting shorter conversion times will result in lower ADC resolution and longer times will result in higher ADC resolution.
- GPIO_ATT[3:0] - Sets attenuation of gpio input voltage when vgpio measured. Defaults to 0xC if ADC_CFG is 0.
 - 0x0 = ADC range 0 to 0.8 V. GPIO_ADC_DIV = 2560
 - 0x4 = ADC range 0 to 1.6 V. GPIO_ADC_DIV = 1280
 - 0x8 = ADC range 0 to 2.4 V. GPIO_ADC_DIV = 853.33
 - 0x9 = ADC range 0 to 3.6 V. GPIO_ADC_DIV = 426.66
 - 0xC = ADC range 0 to 3.2 V. GPIO_ADC_DIV = 640
- Response
 - GPIO_ADC[15:0] - ADC value of voltage on GPIO
 - BATTERY_ADC[15:0] - ADC value of battery voltage
 - TEMP_ADC[15:0] - ADC value of temperature sensor voltage
 - RESERVED[7:0] - RESERVED FOR FUTURE USE
 - RESERVED[7:0] - RESERVED FOR FUTURE USE

8.4. Low Battery Detector

The low battery detector (LBD) is enabled and utilized as part of the wake-up-timer (WUT). The LBD function is not available unless the WUT is enabled, but the host MCU can manually check the battery voltage anytime with the auxiliary ADC. The LBD function is enabled in the GLOBAL_WUT_CONFIG API property. The battery voltage will be compared against the threshold each time the WUT expires. The threshold for the LBD function is set in GLOBAL_LOW_BATT_THRESH. The threshold steps are in increments of 50 mV, ranging from a minimum of 1.5 V up to 3.05 V. The accuracy of the LBD is $\pm 3\%$. The LBD notification can be configured as an interrupt on the nIRQ pin or enabled as a direct function on one of the GPIOs.

8.5. Antenna Diversity

To mitigate the problem of frequency-selective fading due to multipath propagation, some transceiver systems use a scheme known as antenna diversity. In this scheme, two antennas are used. Each time the transceiver enters RX mode the receive signal strength from each antenna is evaluated. This evaluation process takes place during the preamble portion of the packet. The antenna with the strongest received signal is then used for the remainder of that RX packet. This chip fully supports antenna diversity with an integrated antenna diversity control algorithm. The required signals needed to control an external SPDT RF switch (such as a PIN diode or GaAs switch) are available on the GPIO pins. The operation of these GPIO signals is programmable to allow for different antenna diversity architectures and configurations. The antdiv[2:0] bits are found in the MODEM_ANT_DIV_CONTROL API property descriptions and enable the antenna diversity mode. The GPIO pins are capable of sourcing up to 5 mA of current; so, it may be used directly to forward-bias a PIN diode if desired. The antenna diversity algorithm will automatically toggle back and forth between the antennas until the packet starts to arrive. The recommended preamble length for optimal antenna selection is 8 bytes.

9. Pin Descriptions: Si4362

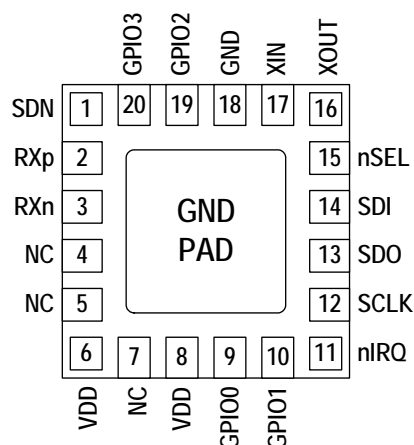

Pin	Pin Name	I/O	Description
1	SDN	I	Shutdown Input Pin. 0–VDD V digital input. SDN should be = 0 in all modes except Shutdown mode. When SDN = 1, the chip will be completely shut down, and the contents of the registers will be lost.
2	RXp	I	Differential RF Input Pins of the LNA. See application schematic for example matching network.
3	RXn	I	
4	NC		No Connect. Not connected internally to any circuitry.
5	NC		No Connect. Not connected internally to any circuitry.
6	VDD	VDD	+1.8 to +3.6 V Supply Voltage Input to Internal Regulators. The recommended VDD supply voltage is +3.3 V.
7	NC		No Connect. Not connected internally to any circuitry.
8	VDD	VDD	+1.8 to +3.6 V Supply Voltage Input to Internal Regulators. The recommended VDD supply voltage is +3.3 V.
9	GPIO0	I/O	General Purpose Digital I/O. May be configured through the registers to perform various functions including: Microcontroller Clock Output, FIFO status, POR, Wake-Up timer, Low Battery Detect, AntDiversity control, etc.
10	GPIO1	I/O	
11	nIRQ	O	General Microcontroller Interrupt Status Output. When the Si4362 exhibits any one of the interrupt events, the nIRQ pin will be set low = 0. The Microcontroller can then determine the state of the interrupt by reading the interrupt status. No external resistor pull-up is required, but it may be desirable if multiple interrupt lines are connected.

Si4362

Pin	Pin Name	I/O	Description
12	SCLK	I	Serial Clock Input. 0–VDD V digital input. This pin provides the serial data clock function for the 4-line serial data bus. Data is clocked into the Si4362 on positive edge transitions.
13	SDO	O	0–VDD V Digital Output. Provides a serial readback function of the internal control registers.
14	SDI	I	Serial Data Input. 0–VDD V digital input. This pin provides the serial data stream for the 4-line serial data bus.
15	nSEL	I	Serial Interface Select Input. 0–VDD V digital input. This pin provides the Select/Enable function for the 4-line serial data bus.
16	XOUT	O	Crystal Oscillator Output. Connect to an external 25 to 32 MHz crystal, or leave floating when driving with an external source on XIN.
17	XIN	I	Crystal Oscillator Input. Connect to an external 25 to 32 MHz crystal, or connect to an external source.
18	GND	GND	Connect to PCB ground.
19	GPIO2	I/O	General Purpose Digital I/O. May be configured through the registers to perform various functions, including Microcontroller Clock Output, FIFO status, POR, Wake-Up timer, Low Battery Detect, AntDiversity control, etc.
20	GPIO3	I/O	
PKG	PADDLE_GND	GND	The exposed metal pad on the bottom of the Si4362 supplies the RF and circuit ground(s) for the entire chip. It is very important that a good solder connection is made between this exposed metal pad and the ground plane of the PCB underlying the Si4362.

10. Ordering Information

Part Number ^{1,2}	Description	Package Type	Operating Temperature
Si4362-Bxx-FM	ISM EZRadioPRO Receiver	QFN-20 Pb-free	-40 to 85 °C

Notes:

1. Add an "(R)" at the end of the device part number to denote tape and reel option.
2. For Bxx, the first "x" indicates the ROM version, and the second "x" indicates the FW version in OTP.

11. Package Outline: Si4362

Figure 13 illustrates the package details for the Si4362. Table 17 lists the values for the dimensions shown in the illustration.

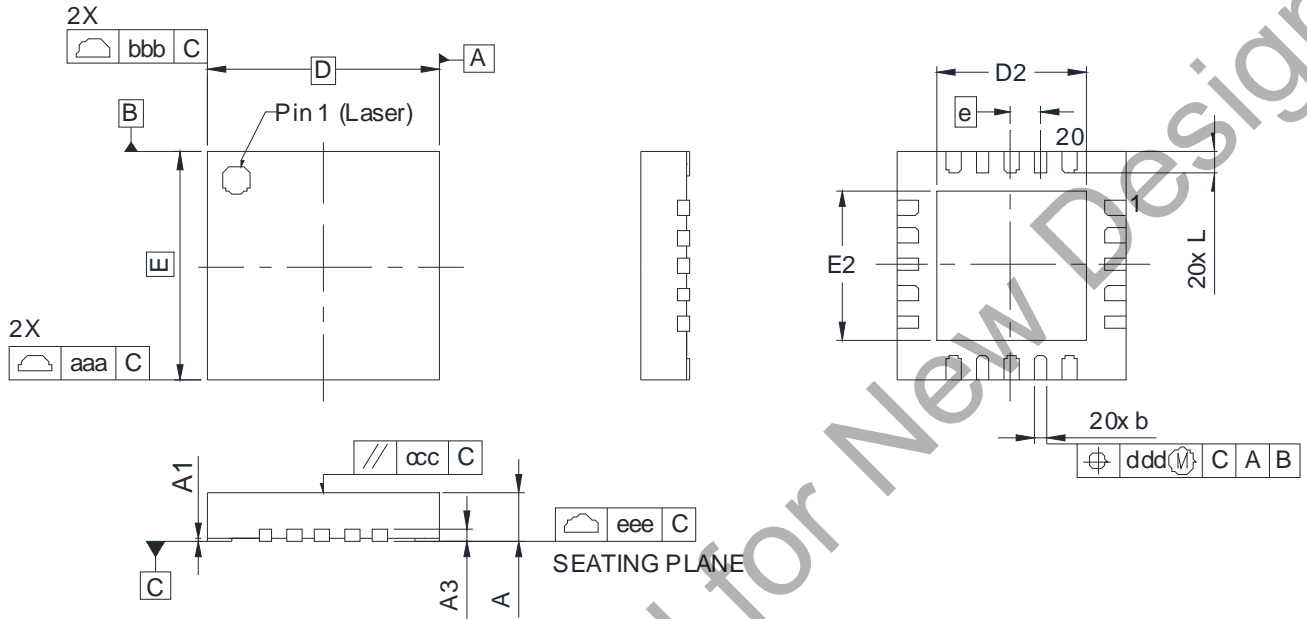

Figure 13. 20-Pin Quad Flat No-Lead (QFN)

Table 17. Package Dimensions

Dimension	Min	Nom	Max
A	0.80	0.85	0.90
A1	0.00	0.02	0.05
A3	0.20 REF		
b	0.18	0.25	0.30
D	4.00 BSC		
D2	2.45	2.60	2.75
e	0.50 BSC		
E	4.00 BSC		
E2	2.45	2.60	2.75
L	0.30	0.40	0.50
aaa	0.15		
bbb	0.15		
ccc	0.10		
ddd	0.10		
eee	0.08		
Notes:			
<ol style="list-style-type: none"> All dimensions are shown in millimeters (mm) unless otherwise noted. Dimensioning and tolerancing per ANSI Y14.5M-1994. This drawing conforms to the JEDEC Solid State Outline MO-220, Variation VGGD-8. Recommended card reflow profile is per the JEDEC/IPC J-STD-020C specification for Small Body Components. 			

12. PCB Land Pattern: Si4362

Figure 14 illustrates the PCB land pattern details for the Si4362. Table 18 lists the values for the dimensions shown in the illustration.

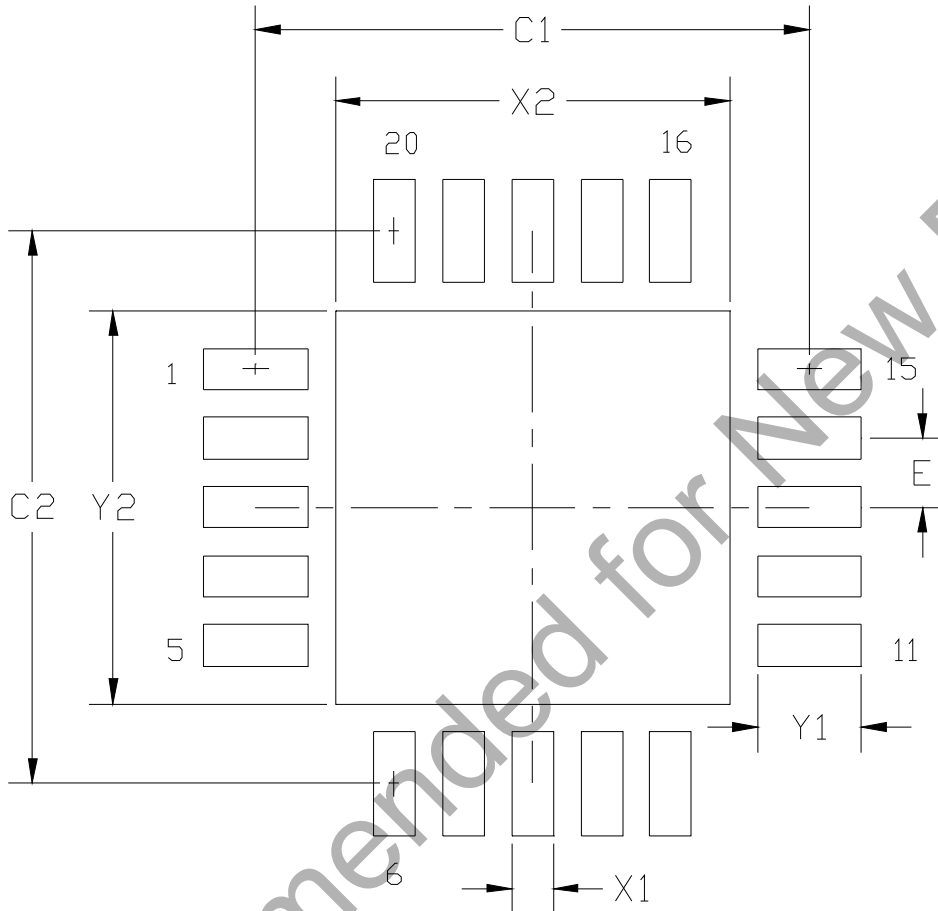

Figure 14. PCB Land Pattern

Table 18. PCB Land Pattern Dimensions

Symbol	Millimeters	
	Min	Max
C1	3.90	4.00
C2	3.90	4.00
E	0.50 REF	
X1	0.20	0.30
X2	2.55	2.65
Y1	0.65	0.75
Y2	2.55	2.65

Notes:

General

1. All dimensions shown are in millimeters (mm) unless otherwise noted.
2. This land pattern design is based on IPC-7351 guidelines.

Solder Mask Design

3. All metal pads are to be non-solder mask defined (NSMD). Clearance between the solder mask and the metal pad is to be 60 μm minimum, all the way around the pad.

Stencil Design

4. A stainless steel, laser-cut and electro-polished stencil with trapezoidal walls should be used to assure good solder paste release.
5. The stencil thickness should be 0.125 mm (5 mils).
6. The ratio of stencil aperture to land pad size should be 1:1 for the perimeter pads.
7. A 2x2 array of 1.10 x 1.10 mm openings on 1.30 mm pitch should be used for the center ground pad.

Card Assembly

8. A No-Clean, Type-3 solder paste is recommended.
9. The recommended card reflow profile is per the JEDEC/IPC J-STD-020 specification for small body components.

Si4362

13. Top Marking

13.1. Si4362 Top Marking

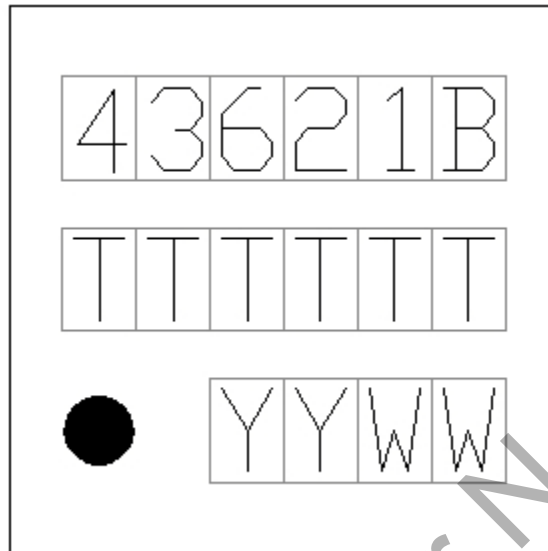

13.2. Top Marking Explanation

Mark Method	YAG Laser	
Line 1 Marking	Part Number	43621B = Si4362 Rev 1B ¹
Line 2 Marking	TTTTT = Internal Code	Internal tracking code. ²
Line 3 Marking	YY = Year WW = Workweek	Assigned by the Assembly House. Corresponds to the last significant digit of the year and workweek of the mold date.
Notes:		
1. The first letter after the part number is part of the ROM revision. The last letter indicates the firmware revision.		
2. The first letter of this line is part of the ROM revision.		

DOCUMENT CHANGE LIST

Revision 0.2 to Revision 0.3

- Updated Table 3, “Synthesizer AC Electrical Characteristics¹,” on page 5.
 - Updated Synthesizer Frequency Range (Si4362) minimum value from “425” to “420”.
 - Updated Synthesizer Frequency Resolution test condition from “425 to 525” to “420 to 525”.
- Updated Table 4, “Receiver AC Electrical Characteristics¹,” on page 6.
 - Updated RX Frequency Range (Si4362) minimum value from “425” to “420”.
- Updated “2. Functional Description” on page 12.
 - Updated Si4362 frequency band range from “425 to 525” to “420 to 525”.
- Updated “5.3. Synthesizer” on page 27.
 - Updated operating band range from “425 to 525” to “420 to 525”.
- Updated Table 14, “Output Divider (Outdiv) Values for the Si4362,” on page 27.
 - Changed “425” to “420”.
- Removed Table 15.

Revision 0.3 to Revision 0.4

- Updated Table 4, “Receiver AC Electrical Characteristics¹,” on page 6.
 - Removed second parameter row.



Simplify Studio

One-click access to MCU tools, documentation, software, source code libraries & more. Available for Windows, Mac and Linux!

www.silabs.com/simplify



MCU Portfolio
www.silabs.com/mcu



SW/HW
www.silabs.com/simplify



Quality
www.silabs.com/quality



Support and Community
community.silabs.com

Disclaimer

Silicon Laboratories intends to provide customers with the latest, accurate, and in-depth documentation of all peripherals and modules available for system and software implementers using or intending to use the Silicon Laboratories products. Characterization data, available modules and peripherals, memory sizes and memory addresses refer to each specific device, and "Typical" parameters provided can and do vary in different applications. Application examples described herein are for illustrative purposes only. Silicon Laboratories reserves the right to make changes without further notice and limitation to product information, specifications, and descriptions herein, and does not give warranties as to the accuracy or completeness of the included information. Silicon Laboratories shall have no liability for the consequences of use of the information supplied herein. This document does not imply or express copyright licenses granted hereunder to design or fabricate any integrated circuits. The products must not be used within any Life Support System without the specific written consent of Silicon Laboratories. A "Life Support System" is any product or system intended to support or sustain life and/or health, which, if it fails, can be reasonably expected to result in significant personal injury or death. Silicon Laboratories products are generally not intended for military applications. Silicon Laboratories products shall under no circumstances be used in weapons of mass destruction including (but not limited to) nuclear, biological or chemical weapons, or missiles capable of delivering such weapons.

Trademark Information

Silicon Laboratories Inc., Silicon Laboratories, Silicon Labs, SiLabs and the Silicon Labs logo, CMEMS®, EFM, EFM32, EFR, Energy Micro, Energy Micro logo and combinations thereof, "the world's most energy friendly microcontrollers", Ember®, EZLink®, EZMac®, EZRadio®, EZRadioPRO®, DSPLL®, ISOmodem®, Precision32®, ProSLIC®, SiPHY®, USBXpress® and others are trademarks or registered trademarks of Silicon Laboratories Inc. ARM, CORTEX, Cortex-M3 and THUMB are trademarks or registered trademarks of ARM Holdings. Keil is a registered trademark of ARM Limited. All other products or brand names mentioned herein are trademarks of their respective holders.



SILICON LABS

Silicon Laboratories Inc.
400 West Cesar Chavez
Austin, TX 78701
USA

<http://www.silabs.com>

Looking for pricing, stock, or lifecycle information?

Click below to explore more details on WIN SOURCE:

 [View SI4362-B1B-FM on WIN SOURCE](#)

 [Silicon Labs](#) Information

Optimize Your Supply Chain with WIN SOURCE Solutions

-  Global Sourcing Solution
-  Obsolete Management
-  Cost Control Management
-  Shortage Management
-  Alternative Solution
-  Excess Inventory Management