



**THE DATASHEET OF**  
**SC1894A-00C13**



## General Description

The SC1894 is the Scintera® 3rd generation of RF PA linearizers (RFPAL™) that provide improved correction and functionality over the previous generations. The SC1894 is a fully adaptive, RFin/RFout predistortion linearization solution optimized for a wide range of amplifiers, power levels, and communication protocols. The SC1894 uses the PA output and input signals to adaptively generate an optimized correction function in order to minimize the PA's self-generated distortion and impairments. Using RF-domain analog signal processing enables the SC1894 to operate over wide-signal bandwidths and consume very low power.

The SC1894 goes beyond linearization and provides accurate RF power measurement of RFIN and RFFB. Design support features including spectral monitoring and ACLR alarm are also available. These design support features are accessed through the SC1894's serial peripheral interface (SPI) bus.

## Applications

- Cellular Infrastructure (SC1894A-00C13)
  - Single/Multicarrier, Multistandard: CDMA/EVDO, TD-SCDMA, WiMAX®, WCDMA/HSDPA, LTE, and TD-LTE
  - BTS Amplifiers, RRH, Booster Amplifiers, Repeaters, Small Cells, Microcells, Picocells, DAS, AAS, and MIMO Systems
- Microwave Backhaul (SC1894A-00M13)
  - BPSK, QPSK, Up to 1024-QAM
  - IF-to-RF Outdoor Unit (ODU)
  - Support for Adaptive Coding and Modulation (ACM) and Automatic Transmit Power Control (ATPC) Up to 100dB/s
- Broadcast Infrastructure (SC1894A-00C13)
  - UHF Digital Broadcast
  - DVB-T/H/T2, CMMB, ISDB-T and ATSC
  - Other Applications: Digital Terrestrial UHF Amplifiers, Exciters, Drivers and Transmitters
- Wide Range of PAs and Output Power
  - Amplifier: Class A/AB and Doherty
  - PA Process: LDMOS, GaN, GaAs, and InGaP
  - Average PA Output Power Examples:
    - Cellular Infrastructure: Up to 49dBm
    - Terrestrial Broadcast: Up to 60dBm
- Any Application Requiring PA Linearization

## Features

- RFin/RFout PA Linearizer SoC in Standard CMOS
  - Fully Adaptive Correction
  - Up to 28dB ACLR and 38dB IMD Improvement\*
- External Reference Clock Support:
  - 10, 13, 15.36, 19.2, 20, 26, and 30.72MHz
- Low Power Consumption:
  - Duty-Cycled (9%) Feedback: 600mW
  - Full Adaptation: 1200mW
- Frequency Range: 225MHz to 3800MHz
- Input Signal Bandwidth: 1.2MHz to 75MHz
- Packaged in 9mm x 9mm QFN Package
- Operating Case Temperature: -40°C to +105°C
- Fully RoHS Compliant, Green Materials
- Dual-RF Power Measurement

## Benefits

- Ease of Use
  - Integrated RFin/RFout Solution
  - Reduced FW Development
- Reduces System Power Consumption and OPEX
- Reduces BOM Costs, Area, and Total Volume
  - Smaller Power Supply, Heat Sink, and Enclosure
  - Eliminates Microcontroller and Power Detectors
  - Small Implementation Size (< 6.5cm<sup>2</sup>)
- Field-Proven, Carrier Class Reliability

**Ordering Information and Application Block Diagram appears at end of data sheet.**

*\*Performance dependent on amplifier, bias, and waveform.*

## Detailed Description

### Introduction to Predistortion Using the SC1894

Wideband signals in today's telecommunications systems have high peak-to-average ratios and stringent spectral regrowth specifications. These specifications place high linearity demands on power amplifiers. Linearity may be achieved by backing off output power at the price of reducing efficiency. However, this increases the component and operating costs of the power amplifier. Better linearity may be achieved through the use of digital predistortion and other linearization techniques, but many of these are time consuming and costly to implement.

Wireless service providers are deploying networks with wider coverage, greater subscriber density, and higher data rates. These networks require more efficient power amplifiers. Additionally, the emergence of distributed architectures and active antenna systems is driving the need for smaller and more efficient power amplifier implementations. Further, there continues to be a strong push toward reducing the total capital and operating costs of base stations.

With the SC1894, the complex signal processing is done in the RF domain. This results in a simple system-on-chip that offers wide signal bandwidth, broad frequency of operation, and very low power consumption. It is an elegant solution that reduces development costs and speeds time to market. Applicable across a broad range of signals — including 2G, 3G, 4G wireless, and other modulation types — the powerful analog signal-processing engine is capable of linearizing the most efficient power amplifier topologies. The SC1894 is a true RFin and RFout solution, supporting modular power amplifier designs that are independent of the baseband and transceiver subsystems. The SC1894 delivers the required efficiency and performance demanded by today's wireless systems.

## RF Power Management Unit (PMU) Description

### Analysis

The RFin and RFFB log slope and intercept are derived using a linear regression performed on data collected under nominal operating conditions. The error from linear response to the CW waveform is the dB difference in output from the ideal output. This is a measure of the linearity of the device response to both CW and modulated waveforms. Error from the linear response to the CW waveform is a measure of relative accuracy because the system has yet to be calibrated. However, it verifies the linearity and the effect of modulation on the device response. Error

from the +25°C performance uses the performance of a given device and waveform type as the reference. This error is largely dominated by output variations associated with temperature.

The PMU codes are represented as 16-bit signed integer and are converted to dBm (referenced to the balun input) using the following formula:

For RFin:

$$P[\text{Balun}](\text{dBm}) = \frac{\text{RFIN PMU (CODE)} \times 3.01}{1024} + \text{OFFSET}_{\text{RFIN}}(\text{dBm})$$

For RFFB:

$$P[\text{Balun}](\text{dBm}) = \frac{\text{RFFB PMU (CODE)} \times 3.01}{1024} + \text{OFFSET}_{\text{RFFB}}(\text{dBm})$$

The  $\text{OFFSET}_{\text{RFIN}}$  and  $\text{OFFSET}_{\text{RFFB}}$  are dependent on end-system characteristics and also on the part-to-part variation of the RFPAL. For absolute accuracy, the PMU calibration procedure outlined in the release notes and SPI programming guide must be followed.

### Measurement Considerations

In order to provide sufficient integration samples to allow precise measurements of signals, the default integration time (measurement window) is fixed to 40ms. Note that if the measurement window is not a multiple of the system frame length, then the power-measurement window will span an incomplete frame and cause a measurement error. However, the synchronization of the frame and measurement window is not required to achieve precise measurements.

### TDD Considerations—Operation with < 100% PA Duty Cycle

The PMU fully supports accurate measurement of TDD waveforms. The PMU does not differentiate between samples taken when the PA is on versus when the PA is off. Though easily compensated, this condition will affect the reading for waveforms with less than 100% duty cycle (e.g., TDD applications). For example, the PMU value read for a 50% duty-cycle waveform will be 3dB lower than the value for the same signal but with a 100% duty cycle. Calculating the offset associated with TDD measurements is straightforward and may be handled by the PMU depending on the system requirements. Refer to the Release Notes for additional details on different methods.

Application Block Diagram

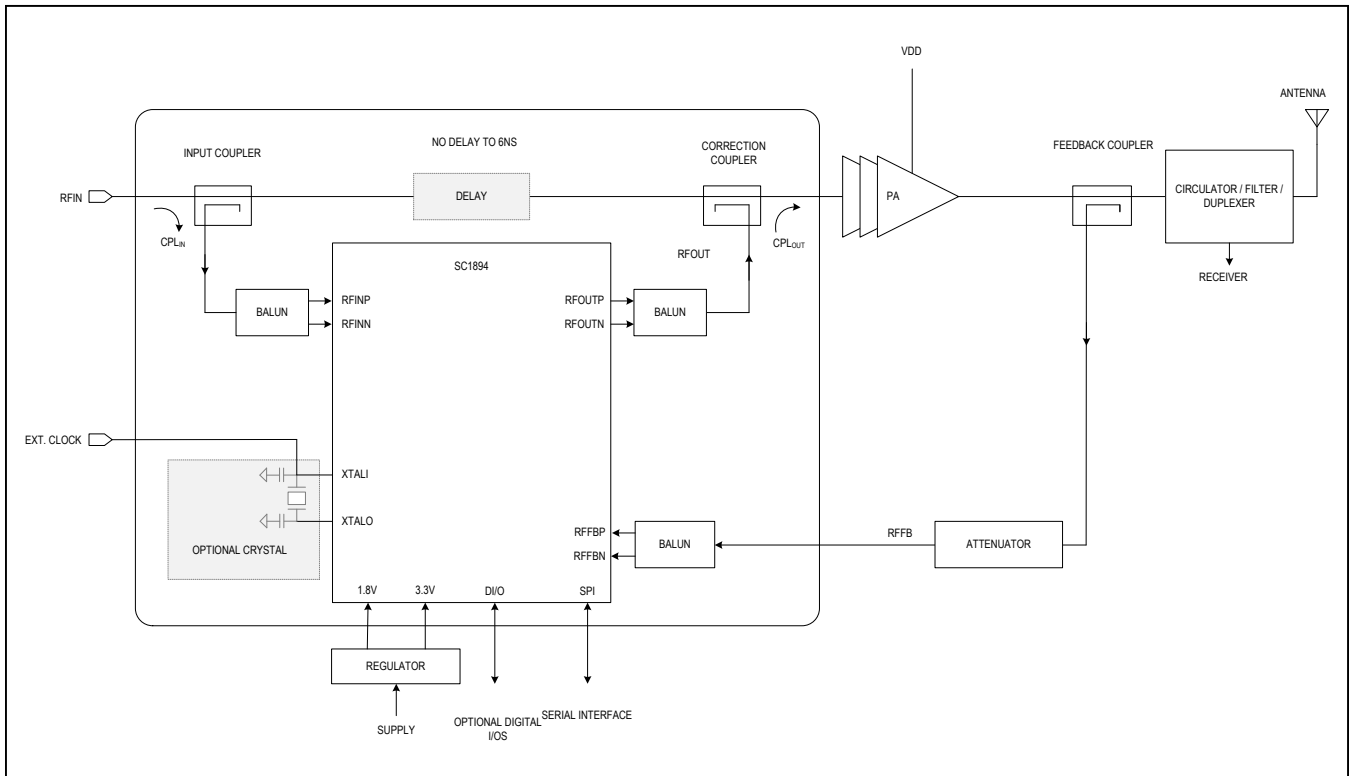

Microwave Block Diagram

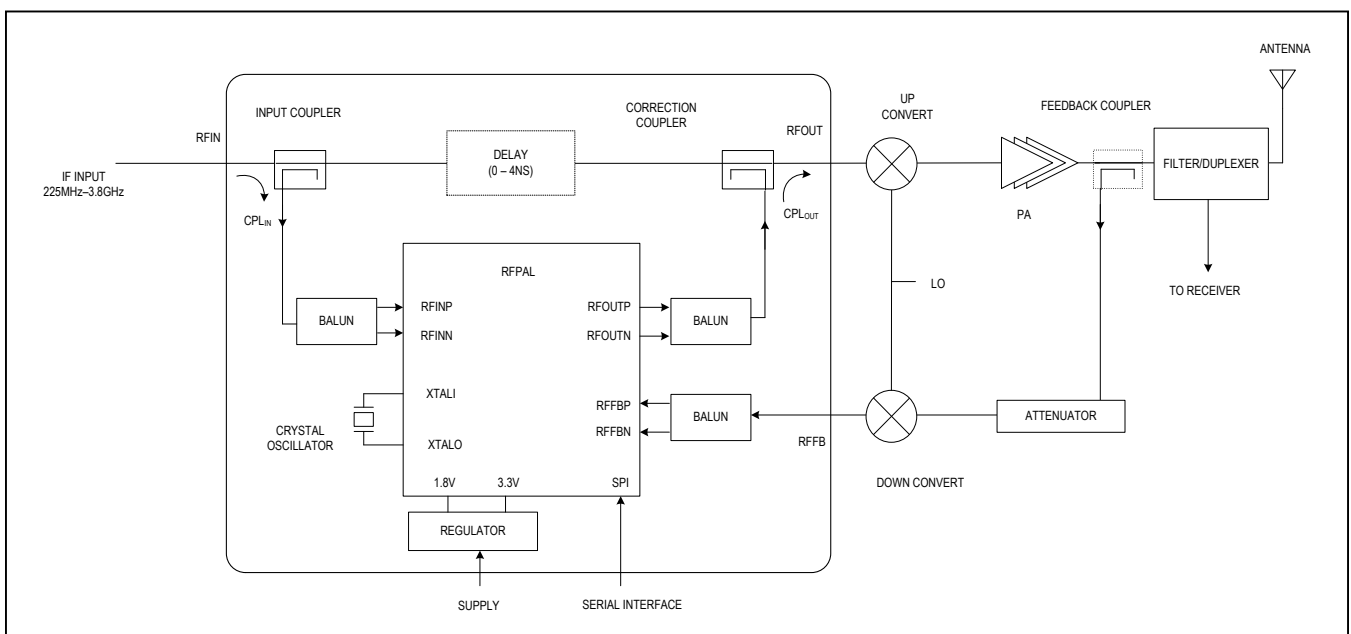

### Absolute Maximum Ratings

Supply Voltage (VDD33 to GND).....	-0.3V to +3.8V	Input into the BALUN (RMS).....	+7dBm
Supply Voltage (VDD18 to GND).....	-0.2V to +2.2V	Junction Temperature.....	+150°C
Input Voltage (1.8V pins).....	-0.2V to VDD18 + 0.2V	Storage Temperature.....	-65°C to +150°C
Input Voltage (3.3V pins).....	-0.3V to VDD33 + 0.3V		

### Operating Rating

Operating Case Temperature.....-40°C to +105°C

**Warning:** Any stress beyond the ranges indicated may damage the device permanently. The specified stress ratings do not imply functional performance in these ranges. Exposure of the device to the absolute maximum ratings for extended periods of time is likely to degrade the reliability of this product.

### DC Characteristics

PARAMETER	MIN	TYP	MAX	UNITS
Supply Voltage (VDD33 to GND)	3.1	3.3	3.5	V
Supply Voltage (VDD18 to GND)	1.7	1.8	1.9	V
Supply Peak Current (VDD33 to GND) (Notes 1, 2, 3, 4)		100	120	mA
Supply Peak Current (VDD18 to GND) (Notes 1, 2, 3, 4)		840	900	mA
Average Power Dissipation: Full-Scale Adaptation, Track and AF (Notes 2, 3, 4)		1200	1400	mW
Average Power Dissipation: Duty-Cycled Feedback (Notes 2, 4, 5)		600		mW

- Note 1:** Peak current includes supply decoupling network. Refer to Hardware Design Guide for proper sizing of the on-board regulators.
- Note 2:** Characterized at typical voltages, +25°C operating case temperature, and 20MHz input signal BW.
- Note 3:** Continuous adaptation, tracking (100% duty-cycled feedback).
- Note 4:** Power dissipation may be FW dependent. Refer to the FW release notes for any changes to values listed above.
- Note 5:** Duty-cycled feedback power dissipation averaged over ON time of 100ms (9%), OFF time of 1.0s (91%).

### Radio Frequency Signals

Operation at +25°C, AVDD18 = 1.8V, AVDD33 = 3.3V, DVDD18 = 1.8V, and 20MHz external clock, unless otherwise specified.

PARAMETER	SYMBOL	CONDITIONS	MIN	TYP	MAX	UNITS
Operating Frequency (Note 6)	f		225		3800	MHz
Input Signal Bandwidth (Note 7)	BW <sub>signal</sub>		1.2	75 (Note 8)		MHz
Noise Power (Note 9)		Referred to 0dBm at PA input		-140	-137	dBm/Hz
In-Band CW Spurious Power (Notes 9, 10)	P <sub>spurLF</sub>	698MHz–960MHz, at RFOUT balun single ended port		-76	-69	dBm
In-Band CW Spurious Power (Notes 9, 10)	P <sub>spurMF</sub>	1800MHz–2200MHz, at RFOUT balun single ended port		-69	-62	dBm
In-Band CW Spurious Power (Notes 9, 10)	P <sub>spurHF</sub>	2400MHz–2700MHz, at RFOUT balun single ended port		-53	-41	dBm

- Note 6:** See Operating Frequency Ranges table for frequency limits of each defined band.
- Note 7:** In the case where 40MHz < BW<sub>signal</sub> ≤ 75MHz and the carrier configuration is NON-fully occupied, then the average power delta between the two outermost carriers must be ≤ 20dB, the carrier configuration must be static (no hopping), the outermost carriers must be ≥ 5MHz and the f<sub>C</sub> must be stored in EEPROM.
- Note 8:** Correction performance across range of input signal BWs also depends on PA output power and carrier configuration.
- Note 9:** Worst case over supply voltage and temperature range, guaranteed by characterization.
- Note 10:** Spurious content is typically due to RFPAL receiver LO leakage and is located within 1MHz of the occupied signal center frequency.

**RF Input Range for Maximum Correction—225MHz to 470MHz**

Operation at +25°C, AVDD18 = 1.8V, AVDD33 = 3.3V, DVDD18 = 1.8V, and 20MHz external clock, unless otherwise specified.

PARAMETER	SYMBOL	CONDITIONS	MIN	TYP	MAX	UNITS
Peak RFIN_BLN (Notes 11, 13)	P <sub>RFIN_BLN_P</sub>	When PA operates at maximum power	-6	0	+2	dBm
Peak RFFB_BLN (Notes 11, 13)	P <sub>RFFB_BLN_P</sub>		-16	-8	-6	dBm
RMS RFIN_BLN (Notes 12, 13)	P <sub>RFIN_BLN</sub>		-13	-10	-8	dBm
RMS RFFB_BLN (Notes 12, 13)	P <sub>RFFB_BLN</sub>		-23	-18	-16	dBm
RFIN_BLN Operating Range	P <sub>RFIN_BLN</sub>	RMS power, over PA output power range	-48		-8	dBm
RFFB_BLN Operating Range	P <sub>RFFB_BLN</sub>		-56		-16	dBm

**RF Input Range for Maximum Correction—470MHz to 700MHz**

Operation at +25°C, AVDD18 = 1.8V, AVDD33 = 3.3V, DVDD18 = 1.8V, and 20MHz external clock, unless otherwise specified.

PARAMETER	SYMBOL	CONDITIONS	MIN	TYP	MAX	UNITS
Peak RFIN_BLN (Note 11, 13)	P <sub>RFIN_BLN_P</sub>	When PA operates at maximum power	-6	0	+2	dBm
Peak RFFB_BLN (Note 11, 13)	P <sub>RFFB_BLN_P</sub>		-16	-8	-6	dBm
RMS RFIN_BLN (Note 12, 13)	P <sub>RFIN_BLN</sub>		-13	-10	-8	dBm
RMS RFFB_BLN (Note 12, 13)	P <sub>RFFB_BLN</sub>		-23	-18	-16	dBm
RFIN_BLN Operating Range	P <sub>RFIN_BLN</sub>	RMS power, over PA output power range	-48		-8	dBm
RFFB_BLN Operating Range	P <sub>RFFB_BLN</sub>		-56		-16	dBm

**RF Input Range for Maximum Correction—700MHz to 2700MHz**

Operation at +25°C, AVDD18 = 1.8V, AVDD33 = 3.3V, DVDD18 = 1.8V, and 20MHz external clock, unless otherwise specified.

PARAMETER	SYMBOL	CONDITIONS	MIN	TYP	MAX	UNITS
Peak RFIN_BLN (Note 11, 13)	P <sub>RFIN_BLN_P</sub>	When PA operates at maximum power	-2	+4	+6	dBm
Peak RFFB_BLN (Note 11, 13)	P <sub>RFFB_BLN_P</sub>		-12	-4	-2	dBm
RMS RFIN_BLN (Note 12, 13)	P <sub>RFIN_BLN</sub>		-9	-6	-4	dBm
RMS RFFB_BLN (Note 12, 13)	P <sub>RFFB_BLN</sub>		-19	-14	-12	dBm
RFIN_BLN Operating Range	P <sub>RFIN_BLN</sub>	RMS power, over PA output power range	-49		-4	dBm
RFFB_BLN Operating Range	P <sub>RFFB_BLN</sub>		-52		-12	dBm

**RF Input Range for Maximum Correction—2700MHz to 3300MHz**

Operation at +25°C, AVDD18 = 1.8V, AVDD33 = 3.3V, DVDD18 = 1.8V, and 20MHz external clock, unless otherwise specified.

PARAMETER	SYMBOL	CONDITIONS	MIN	TYP	MAX	UNITS
Peak RFIN_BLN (Note 11, 13)	P <sub>RFIN_BLN_P</sub>	When PA operates at maximum power		+6		dBm
Peak RFFB_BLN (Note 11, 13)	P <sub>RFFB_BLN_P</sub>			-4		dBm
RMS RFIN_BLN (Note 12, 13)	P <sub>RFIN_BLN</sub>			-4		dBm
RMS RFFB_BLN (Note 12, 13)	P <sub>RFFB_BLN</sub>			-14		dBm
RFIN_BLN Operating Range	P <sub>RFIN_BLN</sub>	RMS power, over PA output power range	-44		-4	dBm
RFFB_BLN Operating Range	P <sub>RFFB_BLN</sub>		-54		-14	dBm

## RF Input Range for Maximum Correction—3300MHz to 3800MHz

Operation at +25°C, AVDD18 = 1.8V, AVDD33 = 3.3V, DVDD18 = 1.8V, and 20MHz external clock, unless otherwise specified.

PARAMETER	SYMBOL	CONDITIONS	MIN	TYP	MAX	UNITS
Peak RFIN_BLN (Note 11, 13)	P <sub>RFIN_BLN_P</sub>	When PA operates at maximum power	+3	+9	+11	dBm
Peak RFFB_BLN (Note 11, 13)	P <sub>RFFB_BLN_P</sub>		-12	-4	-2	dBm
RMS RFIN_BLN (Note 12, 13)	P <sub>RFIN_BLN</sub>		-4	-1	+1	dBm
RMS RFFB_BLN (Note 12, 13)	P <sub>RFFB_BLN</sub>		-19	-14	-12	dBm
RFIN_BLN Operating Range	P <sub>RFIN_BLN</sub>	RMS power, over PA output power range	-41		+1	dBm
RFFB_BLN Operating Range	P <sub>RFFB_BLN</sub>		-52		-12	dBm

**Note 11:** Peak power is defined as the 10<sup>-4</sup> point on the CCDF (complementary cumulative distribution function) of the signal.

**Note 12:** Power (MAX RMS) + PAR must not exceed the peak power limits specified above, there is no maximum limit on the PAR.

**Note 13:** Referred to 50Ω impedance into a 1:2 balun.

## Operating Frequency Ranges

FREQUENCY RANGE (Note 14)	RECOMMENDED APPLICATIONS	DESIGNATION
225MHz to 520MHz	TV white space	-02
225MHz to 960MHz	UHF broadcast, TV White Space, public safety	-03
520MHz to 1040MHz	Low-band cellular (698MHz to 960MHz), UHF broadcast, TV white space, public safety	-04
1040MHz to 2080MHz	LTE for Japan (1400MHz to 1510MHz)	-05
698MHz to 2700MHz	Low- and high-band cellular, IF for SATCOMM (950MHz to 145MHz)	-06
1800MHz to 2700MHz (DEFAULT)	High-band cellular (1800MHz to 2700MHz)	-07
2700MHz to 3500MHz		-08
3300MHz to 3800MHz	Microwave (IF), WiMAX, LTE	-09

**Note 14:** Default is -07. User may reprogram for other ranges listed above. Refer to SPI Programming Guide for programming information.

## Digital I/O—DC Characteristics

Guaranteed performance across worst-case supply voltage and temperature range, unless otherwise specified.

PARAMETER	SYMBOL	CONDITIONS	MIN	TYP	MAX	UNITS
CMOS Input Logic-Low	V <sub>IL</sub>		-0.3		+0.8	V
CMOS Input Logic-High	V <sub>IH</sub>	VDD = 3.3V	2.0			V
CMOS Output Logic-Low	V <sub>OL</sub>				0.4	V
CMOS Output Logic-High	V <sub>OH</sub>	VDD = 3.3V	2.4			V
SDO CMOS Output Current	I <sub>OL</sub> /I <sub>OH</sub>	Three-state	-16.0		+16.0	mA
STATO CMOS Output Current	I <sub>OL</sub> /I <sub>OH</sub>	Open drain	-16.0		0.0	mA

## Digital I/O—External Clock (XTALI)

Guaranteed performance across worst-case supply voltage and temperature range, unless otherwise specified.

PARAMETER	SYMBOL	CONDITIONS	MIN	TYP	MAX	UNITS
User Programmable External Clock (Notes 15, 16)	$f_{CLK}$		10	20	30.72	MHz
External Clock Frequency Accuracy					1	%
External Clock Frequency Drift		Including aging and temperature			100	ppm
Duty Cycle		Square wave	45		55	%
External Clock Amplitude	$V_{CLK}$	Sine or square wave	500		1500	mV <sub>p-p</sub>
External Clock Phase Noise	$PN_{CLK}$	At 100kHz offset			-130	dBc/Hz

**Note 15:** Selecting an external reference clock frequency other than 20MHz requires programming the SC1894 through the SPI bus. See SPI Programming Guide and HW Design Guide for more information.

**Note 16:** User may program the SC1894 to accept the following clock frequencies: 10, 13, 15.36, 19.2, 20, 26 and 30.72MHz.

## Crystal Requirements

Guaranteed performance across worst-case supply voltage and temperature range, unless otherwise specified.

PARAMETER	SYMBOL	CONDITIONS	MIN	TYP	MAX	UNITS
ESR					50	$\Omega$
Capacitive Load to Ground				10	12	pF
Frequency Accuracy					250	ppm
Frequency Drift		Including aging and temperature			100	ppm

## Serial Peripheral Interface (SPI) Bus Specifications

Guaranteed performance across worst-case supply voltage and temperature range unless otherwise specified.

PARAMETER	SYMBOL	CONDITIONS	MIN	TYP	MAX	UNITS
Select Setup Time	$t_{SS}$		100			ns
Select Hold Time	$t_{SH}$		250			ns
Select Disable Time	$t_{DIS}$		100			ns
Data Setup Time	$t_{DS}$		25			ns
Data Hold Time	$t_{DH}$		45			ns
Rise Time	$t_R$				25	ns
Fall Time	$t_F$				25	ns
Clock Period	$t_{CP}$		250			ns
Clock High Time	$t_{CH}$		100			ns
Time to Output Valid	$t_{OV}$				100	ns
Output Data Disable	$t_{OD}$				0	ns

Timing Diagram

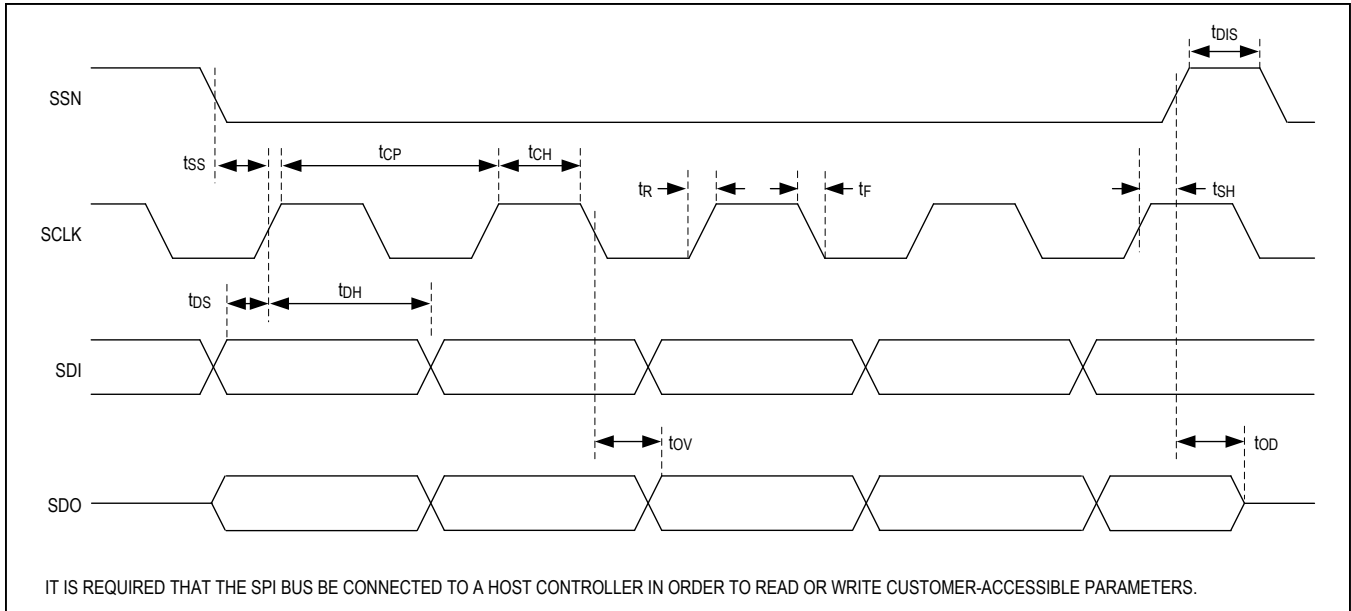

EEPROM Endurance

PARAMETER	SYMBOL	CONDITIONS	MIN	TYP	MAX	UNITS
EEPROM write/erase cycles		Page mode, +25°C	1M			E/W Cycles

RF Power Measurement Electrical Characteristics

RF Power Measurement Unit (PMU)

Operation at +25°C, AVDD18 = 1.8V, AVDD33 = 3.3V, and DVDD18 = 1.8V, unless otherwise specified. Min/Max values are at -40°C < T<sub>case</sub> < +105°C, unless otherwise noted.

PARAMETER	SYMBOL	CONDITIONS (Notes 17, 18)	MIN	TYP	MAX	UNITS
Frequency Range (Note 19)	f <sub>Crange</sub>		698		2500	MHz
RFIN_BLN Range (Note 20)	P <sub>RFINRange</sub>	RMS power, referred to 50Ω impedance into a 1:2 balun	-44 (Note 21) -34 (Note 22)		-4	dBm
RFFB_BLN Range (Note 20)	P <sub>RFFBRange</sub>	RMS power, referred to 50Ω impedance into a 1:2 balun	-52 (Note 21) -42 (Note 22)		-12	dBm
RFIN_BLN Log Slope	μ <sub>RFINslope</sub>	Linear regression between -4 and -39dBm, 100 readings		341.3		LSB/dB
RFFB_BLN Log Slope	μ <sub>RFFBslope</sub>	Linear regression between -12 and -47dBm, 100 readings		341.3		LSB/dB
RFIN_BLN Log Slope Variation	σ <sub>RFINslope</sub>	Linear regression between -4 and -39dBm, 100 readings		±1.2		LSB/dB
RFFB_BLN Log Slope Variation	σ <sub>RFFBslope</sub>	Linear regression between -12 and -47dBm, 100 readings		±1.2		LSB/dB

## RF Power Measurement Electrical Characteristics (continued)

## RF Power Measurement Unit (PMU) (continued)

Operation at +25°C, AVDD18 = 1.8V, AVDD33 = 3.3V, and DVDD18 = 1.8V, unless otherwise specified. Min/Max values are at -40°C < T<sub>case</sub> < +105°C, unless otherwise noted.

PARAMETER	SYMBOL	CONDITIONS (Notes 23, 24)	MIN	TYP	MAX	UNITS
RFIN_BLN Log Intercept	IRFINIntercept	Linear regression between -4 and -34dBm		0		dBm
RFFB_BLN Log Intercept	IRFFBIntercept	Linear regression between -12 and -42dBm		0		dBm
RFIN_BLN Log Intercept Variation	σRFINIntercept	Linear regression between -4 and -34dBm, 100 readings of single IC		±0.12		dB
RFFB_BLN Log Intercept Variation	σRFFBIntercept	Linear regression between -12 and -42dBm, 100 readings of single IC		±0.12		dB
RFIN_BLN Error as Referred to Best-Fit Line (Notes 25, 26)	PRFIN_FITERROR	-4 to -34dBm	-0.30		+0.30	dB
		-34 to -44dBm	-2		+2	dB
RFFB_BLN Error as Referred to Best-Fit Line (Notes 25, 26)	PRFFB_FITERROR	-12 to -42dBm	-0.30		+0.30	dB
		-42 to -52dBm	-2		+2	dB
RFIN_BLN, RFFB_BLN Deviation from 2-Tone CW Response (Note 27)		6.5 dB PAR (WCDMA 1 carrier)		±0.1		dB
		10 dB PAR (WCDMA 1 carrier)		±0.1		dB
		10 dB PAR (LTE 20 carrier)		±0.1		dB
RFIN_BLN Deviation vs. Temperature (Notes 25, 27)	PRFINTEMP_DEV	Deviation from output at 25°C, -40°C < T <sub>case</sub> < +105°C,				
		-4 to -34dBm, at 1800MHz	-0.55	±0.1	+0.55	dB
		-34 to -44dBm, at 1800MHz	-2	±0.5	+2	dB
		-4 to -34dBm, at 2500MHz	-0.7	±0.1	+0.7	dB
RFFB_BLN Deviation vs. Temperature (Notes 25, 27)	PRFFBTEMP_DEV	Deviation from output at +25°C, -40°C < T <sub>case</sub> < +105°C,				
		-12 to -42dBm, at 1800MHz	-0.4	±0.1	+0.4	dB
		-42 to -52dBm, at 1800MHz	-2	±0.5	+2	dB
		-12 to -42dBm, at 2500MHz	-0.5	±0.1	+0.5	dB
RFIN_BLN Deviation vs. Supply Voltage	PRFINVDD18_DEV PRFINVDD33_DEV	1.7V < AVDD18 < 1.9V		+0.7		dB/V
		3.1V < AVDD33 < 3.5V		-0.5		dB/V
RFFB_BLN Deviation vs. Supply Voltage	PRFFBVDD18_DEV PRFFBVDD33_DEV	1.7V < AVDD18 < 1.9V 3.1V < AVDD33 < 3.5V		+0.7 -0.5		dB/V dB/V

**RF Power Measurement Electrical Characteristics (continued)**

**RF Power Measurement Unit (PMU) (continued)**

Operation at +25°C, AVDD18 = 1.8V, AVDD33 = 3.3V, and DVDD18 = 1.8V, unless otherwise specified. Min/Max values are at -40°C < T<sub>case</sub> < +105°C, unless otherwise noted.

PARAMETER	SYMBOL	CONDITIONS (Notes 23, 24)	MIN	TYP	MAX	UNITS
(RFIN_BLN) - (RFFB_BLN) Log Slope	H <sub>RFIN-RFFB</sub> slope			0		LSB/dB
(RFIN_BLN) - (RFFB_BLN) Log Slope Variation	σ <sub>RFIN-RFFB</sub> slope			±1.2		LSB/dB
(RFIN_BLN) - (RFFB_BLN) Error as Referred to Best-Fit Line (Note 26)		RFIN_BLN range (RFFB_BLN = RFIN_BLN – 7dB) -4 to -24dBm -24 to -34dBm	-0.30 -2		+0.30 +2	dB dB
(RFIN_BLN) - (RFFB_BLN) Deviation from 2-Tone CW Response (Note 27)		6.5dB PAR (WCDMA 1 carrier) 10dB PAR (WCDMA 1 carrier) 9.1dB PAR (WCDMA 12 carriers)		±0.1 ±0.1 ±0.1		dB dB dB
(RFIN_BLN) - (RFFB_BLN) Deviation vs. Temperature (Note 27)		Deviation from output at 25°C, -40°C < T <sub>case</sub> < +105°C, -4 to -24dBm, at 2200MHz -24 to -34dBm, at 2200MHz	-0.55 -2	±0.1 ±0.5	+0.55 +2	dB dB

**Note 17:** Test conditions: 2-tone CW (3dB PAR), 5MHz bandwidth and centered at 2140 MHz unless otherwise specified.

**Note 18:** Power measurement updated about every 340ms. The integration time (measurement window) fixed to 40ms.

**Note 19:** For operation above 2500MHz, please contact factory.

**Note 20:** RMS power (MAX) + peak to average ratio (PAR) must not exceed the peak power limits specified in the respective IC data sheets. As long as this condition is met, there is no limitation on the maximum PAR.

**Note 21:** When RFIN\_BLN and RFFB\_BLN are measured sequentially or independently.

**Note 22:** When RFIN\_BLN and RFFB\_BLN are measured simultaneously.

**Note 23:** Test conditions: 2-tone CW (3dB PAR), 5MHz bandwidth and centered at 2140MHz unless otherwise specified.

**Note 24:** Power measurement updated every 340ms. The integration time (measurement window) fixed to 40ms.

**Note 25:** When RFIN\_BLN and RFFB\_BLN are measured sequentially or independently.

**Note 26:** Guaranteed by test (at T<sub>case</sub> = +25°C) and characterization.

**Note 27:** Guaranteed by characterization.

**Typical Operating Characteristics**

Data presented in the figures on the following pages are based on typical operating conditions at +25°C, AVDD18 = 1.8V, AVDD33 = 3.3V, and DVDD18 = 1.8V, unless otherwise specified.

**Measurements (PMU Error as Referred to Best-Fit Line)**

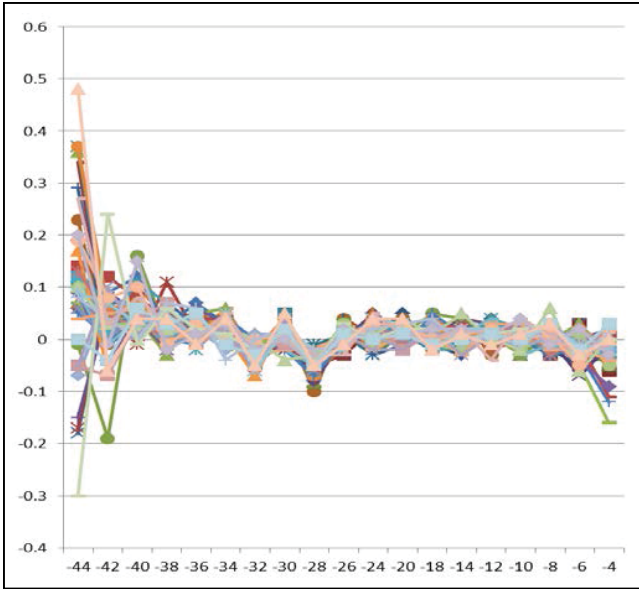

Figure 1. RFIN\_BLN PMU Error as referred to best-fit line vs. RFIN RMS Power, frequency = 1800MHz

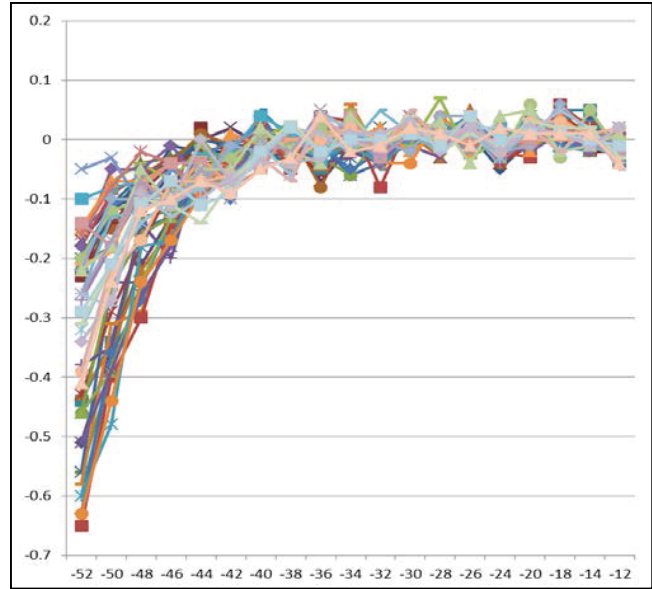

Figure 2. RFFB\_BLN PMU Error as referred to best-fit line vs. RFFB RMS Power, frequency = 1800MHz

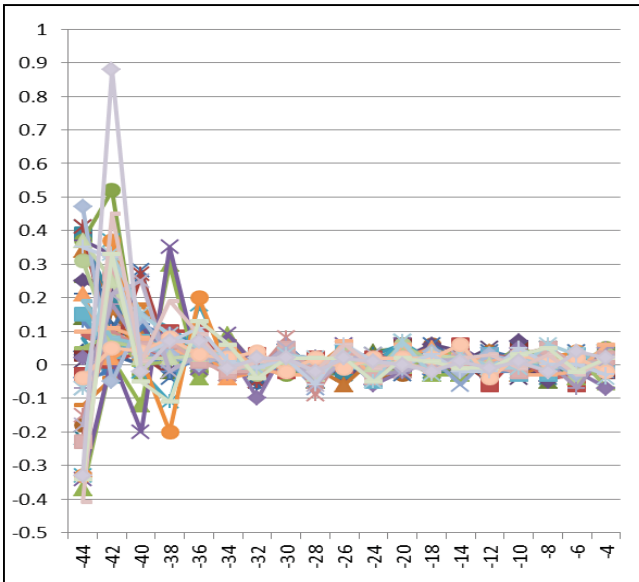

Figure 3. RFIN\_BLN PMU Error as referred to best-fit line vs. RFIN RMS Power, frequency = 2500MHz

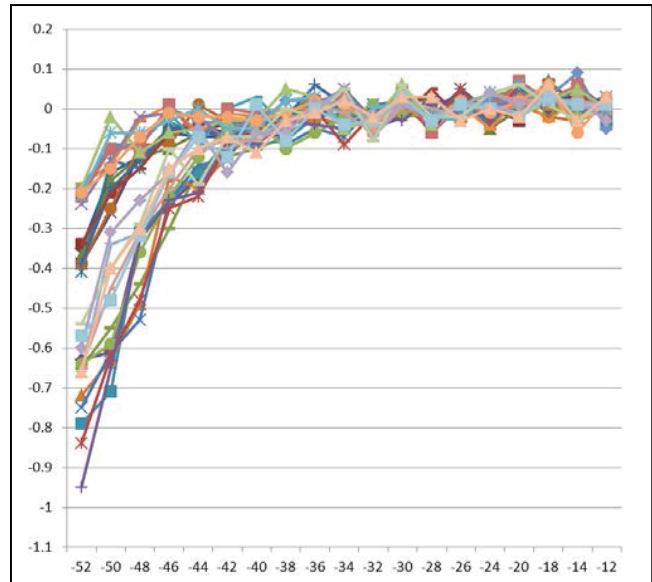

Figure 4. RFFB\_BLN PMU Error as referred to best-fit line vs. RFFB RMS Power, frequency = 2500MHz

**Conditions:**

- Waveforms: WCDMA 2-carrier 6.5dB PAR and LTE 10MHz 7.5dB PAR
- 40°C < T<sub>case</sub> < +105°C
- A/DVDD18 = 1.7V/1.9V, AVDD33 = 3.1V/3.5V

Typical Operating Characteristics (continued)

Data presented in the figures on the following pages are based on typical operating conditions at +25°C, AVDD18 = 1.8V, AVDD33 = 3.3V, and DVDD18 = 1.8V, unless otherwise specified.

Measurements (PMU Deviation from +25°C)

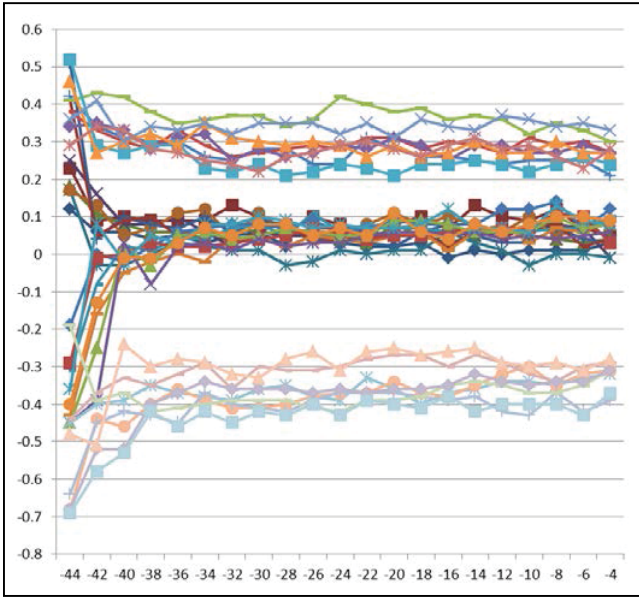

Figure 5. RFIN\_BLN PMU deviation from +25°C vs. RFIN RMS Power, frequency = 1800MHz

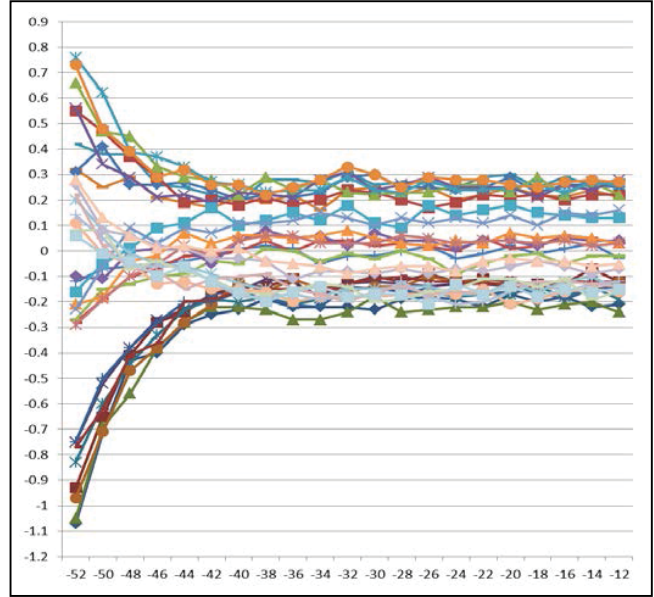

Figure 6. RFFB\_BLN PMU deviation from +25°C vs. RFFB RMS Power, frequency = 1800MHz

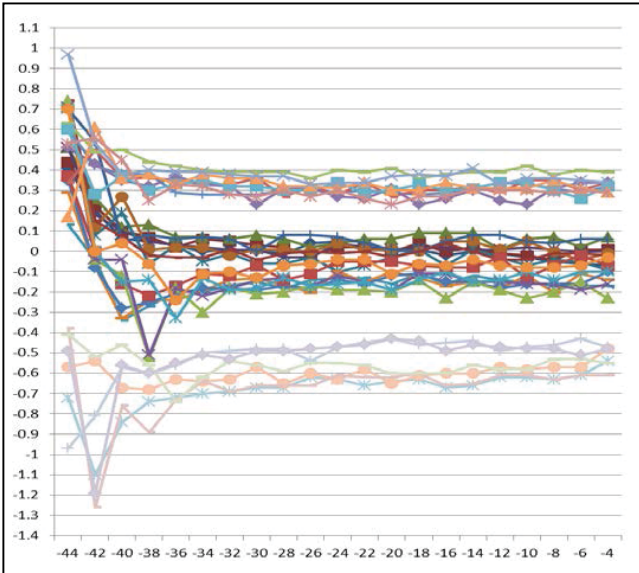

Figure 7. RFIN\_BLN PMU deviation from +25°C vs. RFIN RMS Power, frequency = 2500MHz

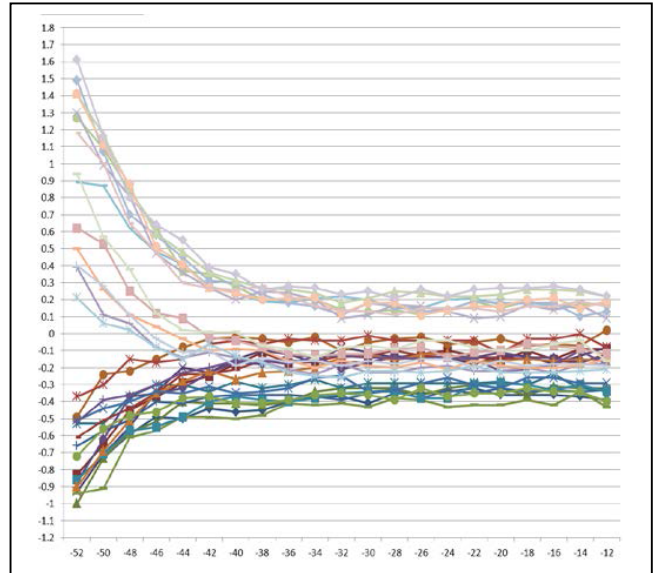
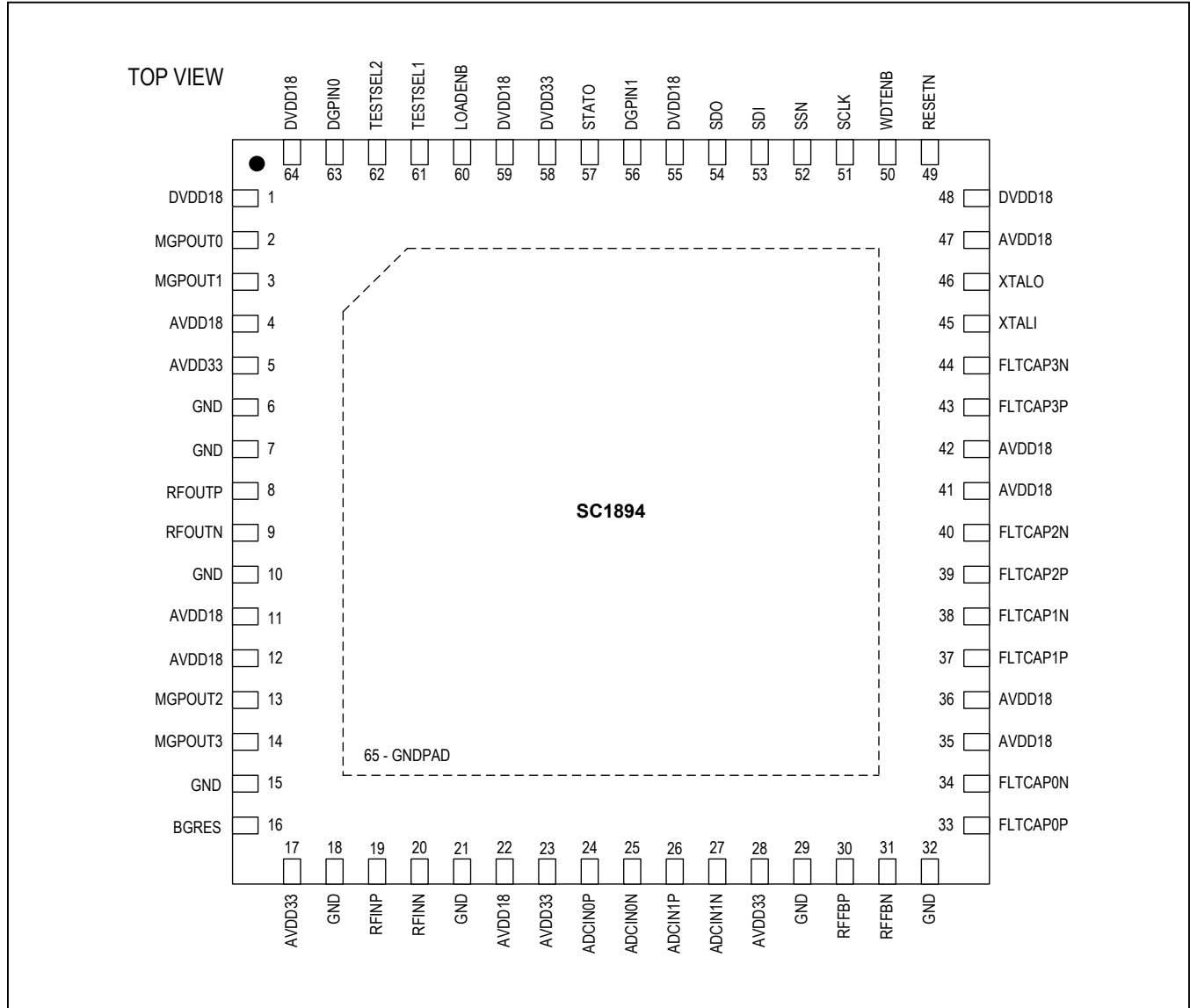

Figure 8. RFFB\_BLN PMU deviation from +25°C vs. RFFB RMS Power, frequency = 2500MHz

Conditions:

- Waveforms: WCDMA-2 carrier 6.5dB PAR and LTE 10MHz 7.5dB PAR
- 40°C < T<sub>case</sub> < +105°C
- A/DVDD18 = 1.7V/1.9V, AVDD33 = 3.1V/3.5V

Pin Configuration



## Pin Description

PIN	NAME	TYPE	FUNCTION
1	DVDD18	Supply	+1.8V DC Supply Voltage for digital circuits.
2	MGPOUT0	Analog Out	Do not connect. Reserved for internal use.
3	MGPOUT1	Analog Out	Do not connect. Reserved for internal use.
4	AVDD18	Supply	+1.8V DC Supply Voltage for analog circuits.
5	AVDD33	Supply	+3.3V DC Supply Voltage for analog circuits.
6	GND	Supply	Ground.
7	GND	RF Shield	Ground for shield of RF signal.
8	RFOUTP	Analog Out	RF Output Signal, differential output. See S-parameters for complex impedance values.
9	RFOUTN		
10	GND	RF Shield	Ground for shield of RF signal.
11	AVDD18	Supply	+1.8V DC Supply Voltage for analog circuits.
12	AVDD18	Supply	+1.8V DC Supply Voltage for analog circuits.
13	MGPOUT2	Analog Out	Do not connect. Reserved for internal use.
14	MGPOUT3	Analog Out	Do not connect. Reserved for internal use.
15	GND	Supply	Ground.
16	BGRES	Analog In	Bandgap Resistor.
17	AVDD33	Supply	+3.3V DC Supply Voltage for analog circuits.
18	GND	RF Shield	Ground for shield of RF signal.
19	RFINP	Analog In	RF Input Signal, differential input. See S-parameters for complex impedance values.
20	RFINN	Analog In	
21	GND	RF Shield	Ground for shield of RF signal.
22	AVDD18	Supply	+1.8V DC Supply Voltage for analog circuits.
23	AVDD33	Supply	+3.3V DC Supply Voltage for analog circuits.
24	ADCIN0P	Analog In	Do not connect. Reserved for internal use.
25	ADCIN0N	Analog In	Do not connect. Reserved for internal use.
26	ADCIN1P	Analog In	Do not connect. Reserved for internal use.
27	ADCIN1N	Analog In	Do not connect. Reserved for internal use.
28	AVDD33	Supply	+3.3V DC Supply Voltage for analog circuits.
29	GND	RF Shield	Ground for shield of RF signal.
30	RFFBP	Analog In	RF Feedback Signal, differential input. See S-parameters for complex impedance values.
31	RFFBN		
32	GND	RF Shield	Ground for shield of RF signal.
33	FLTCAP0P	Analog Out	Dedicated external filter capacitor #0.
34	FLTCAP0N		
35	AVDD18	Supply	+1.8V DC Supply Voltage for analog circuits.
36	AVDD18	Supply	+1.8V DC Supply Voltage for analog circuits.

## Pin Description (continued)

PIN	NAME	TYPE	FUNCTION
37	FLTCAP1P	Analog Out	Dedicated external filter capacitor #1.
38	FLTCAP1N		
39	FLTCAP2P	Analog Out	Dedicated external filter capacitor #2.
40	FLTCAP2N		
41	AVDD18	Supply	+1.8V DC Supply Voltage for analog circuits.
42	AVDD18	Supply	+1.8V DC Supply Voltage for analog circuits.
43	FLTCAP3P	Analog Out	Dedicated external filter capacitor #3.
44	FLTCAP3N		
45	XTALI	Analog In	Crystal Input. For standard internal clock, connect crystal or ceramic resonator from XTALI to XTALO. May alternatively be driven by an external clock.
46	XTALO	Analog Out	Crystal Output. Excitation driver for crystal or ceramic resonator.
47	AVDD18	Supply	+1.8V DC Supply Voltage for analog circuits.
48	DVDD18	Supply	+1.8V DC Supply Voltage for digital circuits.
49	RESETN	Digital In	Reset when "Low". Has internal pull-up to DVDD33.
50	WDTENB	Digital In	Watch Dog Timer Enable. WDTENB enabled when high. Has internal pull-up to DVDD33. See applications schematic for further details.
51	SCLK	Digital In	SPI clock. Has internal pull-down to GND.
52	SSN	Digital In	SPI slave select enabled "Low". Has internal pull-up to DVDD33.
53	SDI	Digital In	SPI slave data input to RFPAL. Has internal pull-down to GND.
54	SDO	Digital Out	SPI slave data output from RFPAL. Tri-state. DVDD33 logic.
55	DVDD18	Supply	+1.8V DC Supply Voltage for digital circuits.
56	DGPIN1	Digital In	Digital General Purpose Input 1. Has internal pull-up to DVDD33. See Firmware Release Notes for further details.
57	STATO	Digital Out	General Purpose Status Output as defined in Firmware Release Notes. Open-drain output with internal pull-up to DVDD33.
58	DVDD33	Supply	+3.3V DC Supply Voltage for digital circuits.
59	DVDD18	Supply	+1.8V DC Supply Voltage for digital circuits.
60	LOADENB	Digital In	Load Enable. Required for FW upgrades. Has internal pull-down to GND. See applications schematic for further details.
61	TESTSEL1	Reserved	Do not connect. Reserved for internal use. Has internal pull-down to GND.
62	TESTSEL2	Reserved	Do not connect. Reserved for internal use. Has internal pull-down to GND.
63	DGPIN0	Digital In	Digital General Purpose Input 0. Do not connect. Reserved for future use. Has internal pull-down to GND. See applications schematic for further details.
64	DVDD18	Supply	+1.8V DC Supply Voltage for digital circuits.
65	GNDPAD	Supply	Common Ground for entire integrated circuit. Also provides path for thermal dissipation.

SC1894

225MHz to 3800MHz RF Power  
Amplifier Linearizer (RFPAL)

**Top Mark**

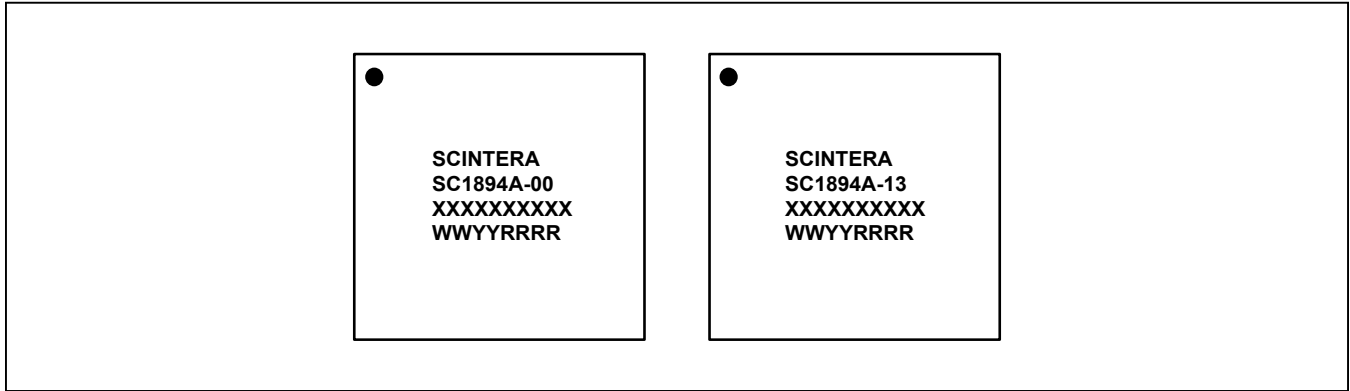

LINE	TOP MARK	DESCRIPTION
1	SCINTERA	Company Name
2	SC1894	Product Part Number
2	A	Product Revision
2	-00 -13	Product Configuration (PC): -00 = All features enabled -13 = All features enabled*
3	XXXXXXXXXX	Assembly Lot Number (up to 10 characters)
4	WW	Date Code - Work Week
4	YY	Date Code - Year
4	RRRR	Reserved

\*Recommended for new designs.

**ESD**

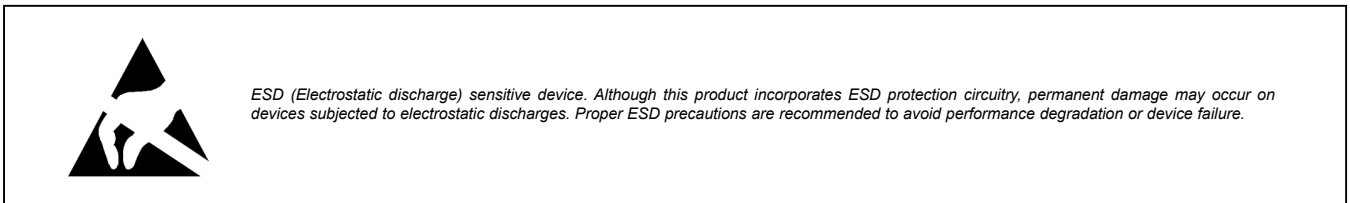

**Electrostatic Discharge (ESD) Protection Characteristics**

TEST METHODOLOGY	CLASS	VOLTAGE	UNIT
Human Body Model (per JESD22-A114)	1C	1000	V
Charge Device Model (per JESD22-C101)	II	250	V

**Ordering Information**

PART NUMBER	DESCRIPTION
SC1894A-00B00	IC, RFPAL, 225MHz–3800MHz, FW4.1.05.01
SC1894A-00B13	IC, RFPAL, 225MHz–3800MHz, FW4.1.05.01
SC1894A-00C13*	IC, RFPAL, 225MHz–3800MHz, FW4.1.03.08 (for all other applications)
SC1894A-00M13*	IC, RFPAL, 225MHz–3800MHz, FW4.1.07.00 (for microwave applications)
SC1894A-00N13*	IC, RFPAL, 225MHz–3800MHz, FW4.5.01.00 (for narrow band applications)

\*Recommended for new designs.

**Shipping Designator:**

E = 7in tape and reel

Append shipping designator (E) at end of part number. If left blank, designates bulk shipping option.

**Evaluation Kit Ordering Information**

PART NUMBER	DESCRIPTION
SC1894-EVK200	Eval Kit, RFPAL, 225-470MHz
SC1894-EVK500	Eval Kit, RFPAL, 470-928MHz
SC1894-EVK900	Eval Kit, RFPAL, 698-960MHz
SC1894-EVK1500	Eval Kit, RFPAL, 1350-1800MHz
SC1894-EVK1900	Eval Kit, RFPAL, 1800-2200MHz
SC1894-EVK2400	Eval Kit, RFPAL, 2300-2700MHz
SC1894-EVK3400	Eval Kit, RFPAL, 3300-3800MHz
SC-USB-SPI*	Adapter, SPI-USB Interface/Controller

\*To be ordered separately from the evaluation kit.

**Package Information**

For the latest package outline information and land patterns (footprints), go to [www.maximintegrated.com/packages](http://www.maximintegrated.com/packages). Note that a “+”, “#”, or “-” in the package code indicates RoHS status only. Package drawings may show a different suffix character, but the drawing pertains to the package regardless of RoHS status.

PACKAGE TYPE	PACKAGE CODE	OUTLINE NO.	LAND PATTERN NO.
64 QFN	K6499MK+1B	<a href="#">21-0765</a>	<a href="#">90-0605</a>

## Revision History

REVISION NUMBER	REVISION DATE	DESCRIPTION	PAGES CHANGED
0.2	9/14	Initial release	—
0.3	12/14	Added part number for microwave applications	1, 4
0.4	12/14	Added microwave block diagram	3
1	7/20	Added part number SC1894A-00N13* to <i>Ordering Information</i> table	17

For pricing, delivery, and ordering information, please contact Maxim Direct at 1-888-629-4642, or visit Maxim Integrated's website at [www.maximintegrated.com](http://www.maximintegrated.com).

*Maxim Integrated cannot assume responsibility for use of any circuitry other than circuitry entirely embodied in a Maxim Integrated product. No circuit patent licenses are implied. Maxim Integrated reserves the right to change the circuitry and specifications without notice at any time. The parametric values (min and max limits) shown in the Electrical Characteristics table are guaranteed. Other parametric values quoted in this data sheet are provided for guidance.*

## Looking for pricing, stock, or lifecycle information?

Click below to explore more details on WIN SOURCE:

 [View SC1894A-00C13 on WIN SOURCE](#)

 [Maxim Integrated Information](#)

## Optimize Your Supply Chain with WIN SOURCE Solutions

-  Global Sourcing Solution
-  Obsolete Management
-  Cost Control Management
-  Shortage Management
-  Alternative Solution
-  Excess Inventory Management