



**THE DATASHEET OF  
TC275TP64F200WDCKXUMA1**



# 32-Bit

Microcontroller

## TC270 / TC275 / TC277

32-Bit Single-Chip Micocontroller  
DB-Step

## 32-Bit Single-Chip Micocontroller

### Data Sheet

V 1.2, 2019-04

**Edition 2019-04**

**Published by  
Infineon Technologies AG  
81726 Munich, Germany**

**© 2019 Infineon Technologies AG  
All Rights Reserved.**

### **Legal Disclaimer**

The information given in this document shall in no event be regarded as a guarantee of conditions or characteristics. With respect to any examples or hints given herein, any typical values stated herein and/or any information regarding the application of the device, Infineon Technologies hereby disclaims any and all warranties and liabilities of any kind, including without limitation, warranties of non-infringement of intellectual property rights of any third party.

### **Information**

For further information on technology, delivery terms and conditions and prices, please contact the nearest Infineon Technologies Office ([www.infineon.com](http://www.infineon.com))

### **Warnings**

Due to technical requirements, components may contain dangerous substances. For information on the types in question, please contact the nearest Infineon Technologies Office.

Infineon Technologies components may be used in life-support devices or systems only with the express written approval of Infineon Technologies, if a failure of such components can reasonably be expected to cause the failure of that life-support device or system or to affect the safety or effectiveness of that device or system. Life support devices or systems are intended to be implanted in the human body or to support and/or maintain and sustain and/or protect human life. If they fail, it is reasonable to assume that the health of the user or other persons may be endangered.

---

**Revision History**

Page or Item	Subjects (major changes since previous revision)
V 1.2, 2019-04	
	The history is documented in the last chapter

**Trademarks of Infineon Technologies AG**

AURIX™, C166™, CanPAK™, CIPOS™, CIPURSE™, EconoPACK™, CoolMOS™, CoolSET™, CORECONTROL™, CROSSAVE™, DAVE™, DI-POL™, EasyPIM™, EconoBRIDGE™, EconoDUAL™, EconoPIM™, EconoPACK™, EiceDRIVER™, eupec™, FCOS™, HITFET™, HybridPACK™, I<sup>2</sup>RF™, ISOFACE™, IsoPACK™, MIPAQ™, ModSTACK™, my-d™, NovalithIC™, OptiMOS™, ORIGA™, POWERCODE™; PRIMARION™, PrimePACK™, PrimeSTACK™, PRO-SIL™, PROFET™, RASIC™, ReverSave™, SatRIC™, SIEGET™, SINDRION™, SIPMOS™, SmartLEWIS™, SOLID FLASH™, TEMPFET™, thinQ!™, TRENCHSTOP™, TriCore™.

**Other Trademarks**

Advance Design System™ (ADS) of Agilent Technologies, AMBA™, ARM™, MULTI-ICE™, KEIL™, PRIMECELL™, REALVIEW™, THUMB™,  $\mu$ Vision™ of ARM Limited, UK. AUTOSAR™ is licensed by AUTOSAR development partnership. Bluetooth™ of Bluetooth SIG Inc. CAT-iq™ of DECT Forum. COLOSSUS™, FirstGPS™ of Trimble Navigation Ltd. EMV™ of EMVCo, LLC (Visa Holdings Inc.). EPCOS™ of Epcos AG. FLEXGO™ of Microsoft Corporation. FlexRay™ is licensed by FlexRay Consortium. HYPERTERMINAL™ of Hilgraeve Incorporated. IEC™ of Commission Electrotechnique Internationale. IrDA™ of Infrared Data Association Corporation. ISO™ of INTERNATIONAL ORGANIZATION FOR STANDARDIZATION. MATLAB™ of MathWorks, Inc. MAXIM™ of Maxim Integrated Products, Inc. MICROTEC™, NUCLEUS™ of Mentor Graphics Corporation. MIPI™ of MIPI Alliance, Inc. MIPS™ of MIPS Technologies, Inc., USA. muRata™ of MURATA MANUFACTURING CO., MICROWAVE OFFICE™ (MWO) of Applied Wave Research Inc., OmniVision™ of OmniVision Technologies, Inc. Openwave™ Openwave Systems Inc. RED HAT™ Red Hat, Inc. RFMD™ RF Micro Devices, Inc. SIRIUS™ of Sirius Satellite Radio Inc. SOLARIS™ of Sun Microsystems, Inc. SPANSION™ of Spansion LLC Ltd. Symbian™ of Symbian Software Limited. TAIYO YUDEN™ of Taiyo Yuden Co. TEAKLITE™ of CEVA, Inc. TEKTRONIX™ of Tektronix Inc. TOKO™ of TOKO KABUSHIKI KAISHA TA. UNIX™ of X/Open Company Limited. VERILOG™, PALLADIUM™ of Cadence Design Systems, Inc. VLYNQ™ of Texas Instruments Incorporated. VXWORKS™, WIND RIVER™ of WIND RIVER SYSTEMS, INC. ZETEX™ of Diodes Zetex Limited.

Last Trademarks Update 2011-11-11

## Table of Contents

<b>1</b>	<b>Summary of Features</b>	<b>3</b>
<b>2</b>	<b>Package and Pinning Definitions</b>	<b>7</b>
2.1	TC275x Pin Definition and Functions: LQFP176	8
2.1.1	TC275x LQFP176 Package Variant Pin Configuration'	9
2.1.2	Emergency Stop Function	63
2.1.3	Pull-Up/Pull-Down Reset Behavior of the Pins	64
2.2	TC277x Pin Definition and Functions: BGA292	65
2.2.1	TC277xBGA292 Package Variant Pin Configuration	66
2.2.2	Emergency Stop Function	136
2.2.3	Pull-Up/Pull-Down Reset Behavior of the Pins	137
2.3	TC270x Bare Die Pad Definition	138
2.3.1	Pad Openings	151
2.3.2	Emergency Stop Function	151
2.3.3	Pull-Up/Pull-Down Reset Behavior of the Pins	152
<b>3</b>	<b>Electrical Specification</b>	<b>153</b>
3.1	Parameter Interpretation	153
3.2	Absolute Maximum Ratings	154
3.3	Pin Reliability in Overload	155
3.4	Operating Conditions	158
3.5	5 V / 3.3 V switchable Pads	160
3.6	3.3 V only Pads	178
3.7	High performance LVDS Pads (LVDSH)	180
3.8	Medium performance LVDS Pads (LVDSM)	184
3.9	VADC Parameters	185
3.10	DSADC Parameters	191
3.11	MHz Oscillator	196
3.12	Back-up Clock	197
3.13	Temperature Sensor	198
3.14	Power Supply Current	199
3.14.1	Calculating the 1.3 V Current Consumption	202
3.15	Power-up and Power-down	203
3.15.1	External Supply Mode	203
3.15.2	Single Supply Mode	205
3.15.3	External Supply Mode	207
3.15.4	Single Supply Mode	209
3.16	Reset Timing	211
3.17	EVR	213
3.18	Phase Locked Loop (PLL)	218
3.19	ERAY Phase Locked Loop (ERAY_PLL)	219
3.20	AC Specifications	220
3.21	JTAG Parameters	221
3.22	DAP Parameters	223
3.23	ASCLIN SPI Master Timing	225
3.24	ASCLIN SPI Master Timing	229
3.25	QSPI Timings, Master and Slave Mode	233
3.26	QSPI Timings, Master and Slave Mode	238
3.27	MSC Timing 5 V Operation	245
3.28	MSC Timing 3.3 V Operation	250

3.29	Ethernet Interface (ETH) Characteristics	255
3.29.1	ETH Measurement Reference Points	255
3.29.2	ETH Management Signal Parameters (ETH_MDC, ETH_MDIO)	256
3.29.3	ETH MII Parameters	257
3.29.4	ETH RMII Parameters	258
3.30	E-Ray Parameters	259
3.31	HSCT Parameters	261
3.32	Inter-IC (I2C) Interface Timing	264
3.33	Flash Target Parameters	267
3.34	Package Outline	270
3.34.1	Package Parameters	271
3.34.2	TC270 Carrier Tape	271
3.35	Quality Declarations	273
<b>4</b>	<b>History</b>	<b>274</b>
4.1	Changes from version version 0.6 to 0.7	274
4.2	Changes from version version 0.7 to 1.0	281
4.3	Changes from version version 1.0 to 1.1	284
4.4	Changes from version version 1.1 to 1.2	284

## 1 Summary of Features

The TC27x product family has the following features:

- High Performance Microcontroller with three CPU cores
- Two 32-bit super-scalar TriCore CPUs (TC1.6P), each having the following features:
  - Superior real-time performance
  - Strong bit handling
  - Fully integrated DSP capabilities
  - Multiply-accumulate unit able to sustain 2 MAC operations per cycle
  - Fully pipelined Floating point unit (FPU)
  - up to 200 MHz operation at full temperature range
  - up to 120 Kbyte Data Scratch-Pad RAM (DSPR)
  - up to 32 Kbyte Instruction Scratch-Pad RAM (PSPR)
  - 16 Kbyte Instruction Cache (ICACHE)
  - 8 Kbyte Data Cache (DCACHE)
- Power Efficient scalar TriCore CPU (TC1.6E), having the following features:
  - Binary code compatibility with TC1.6P
  - up to 200 MHz operation at full temperature range
  - up to 112 Kbyte Data Scratch-Pad RAM (DSPR)
  - up to 24 Kbyte Instruction Scratch-Pad RAM (PSPR)
  - 8 Kbyte Instruction Cache (ICACHE)
  - 0.125Kbyte Data Read Buffer (DRB)
- Lockstepped shadow cores for one TC1.6P and for TC1.6E
- Multiple on-chip memories
  - All embedded NVM and SRAM are ECC protected
  - up to 4 Mbyte Program Flash Memory (PFLASH)
  - up to 384 Kbyte Data Flash Memory (DFLASH) usable for EEPROM emulation
  - 32 Kbyte Memory (LMU)
  - BootROM (BROM)
- 64-Channel DMA Controller with safe data transfer
- Sophisticated interrupt system (ECC protected)
- High performance on-chip bus structure
  - 64-bit Cross Bar Interconnect (SRI) giving fast parallel access between bus masters, CPUs and memories
  - 32-bit System Peripheral Bus (SPB) for on-chip peripheral and functional units
  - One bus bridge (SFI Bridge)
- Optional Hardware Security Module (HSM) on some variants
- Safety Management Unit (SMU) handling safety monitor alarms
- Memory Test Unit with ECC, Memory Initialization and MBIST functions (MTU)
- Hardware I/O Monitor (IOM) for checking of digital I/O
- Versatile On-chip Peripheral Units
  - Four Asynchronous/Synchronous Serial Channels (ASCLIN) with hardware LIN support (V1.3, V2.0, V2.1 and J2602) up to 50 MBaud

---

**Summary of Features**

- Four Queued SPI Interface Channels (QSPI) with master and slave capability up to 50 Mbit/s
- High Speed Serial Link (HSSL) for serial inter-processor communication up to 320 Mbit/s
- Two serial Micro Second Bus interfaces (MSC) for serial port expansion to external power devices
- One MultiCAN+ Module with 4 CAN nodes and 256 free assignable message objects for high efficiency data handling via FIFO buffering and gateway data transfer
- 10 Single Edge Nibble Transmission (SENT) channels for connection to sensors
- One FlexRay™ module with 2 channels (E-Ray) supporting V2.1
- One Generic Timer Module (GTM) providing a powerful set of digital signal filtering and timer functionality to realize autonomous and complex Input/Output management
- One Capture / Compare 6 module (Two kernels CCU60 and CCU61)
- One General Purpose 12 Timer Unit (GPT120)
- Three channel Peripheral Sensor Interface conforming to V1.3 (PSI5)
- Peripheral Sensor Interface with Serial PHY (PSI5-S)
- Optional Inter-Integrated Circuit Bus Interface (I2C) conforming to V2.1
- Optional IEEE802.3 Ethernet MAC with RMII and MII interfaces (ETH)
- Versatile Successive Approximation ADC (VADC)
  - Cluster of 8 independent ADC kernels
  - Input voltage range from 0 V to 5.5V (ADC supply)
- Delta-Sigma ADC (DSADC)
  - Six channels
- Digital programmable I/O ports
- On-chip debug support for OCDS Level 1 (CPUs, DMA, On Chip Buses)
- multi-core debugging, real time tracing, and calibration
- four/five wire JTAG (IEEE 1149.1) or DAP (Device Access Port) interface
- Power Management System and on-chip regulators
- Clock Generation Unit with System PLL and Flexray PLL
- Embedded Voltage Regulator

**Ordering Information**

The ordering code for Infineon microcontrollers provides an exact reference to the required product. This ordering code identifies:

- The derivative itself, i.e. its function set, the temperature range, and the supply voltage
- The package and the type of delivery.

For the available ordering codes for the TC270 / TC275 / TC277 please refer to the “**AURIX TC27x Microcontrollers Variant Overview**”, which summarizes all available variants.

**Table 1-1 Overview of TC27x Functions**

Feature		
CPU Core	Type	TC1.6P / TC1.6E
	P Cores / Checker Cores / E Cores / Checker Cores	2 / 1 / 1 / 1
	Max. Freq.	200 MHz
	FPU	yes
Program Flash	Size	4 Mbyte
Data Flash	Size	384 Kbyte
Cache	Instruction (P / E)	16 Kbyte / 8 Kbyte
	Data (P / E)	8 Kbyte / -
SRAM	Size TC1.6P (DSPR/PSPR)	120 Kbyte / 32 Kbyte <sup>2)</sup>
	Size TC1.6E (DSPR/PSPR)	112 Kbyte / 24 Kbyte <sup>1) 2)</sup>
	Size LMU	32 Kbyte
DMA	Channels	64
ADC	Channels	48 + 12
	Converter	8
DSADC	Channels	6
GTM	TIM	4
	TOM	3
	ATOM / MCS	5 / 4
	CMU / ICM	1 / 1
	PSM	1
	TBU	1
	SPE	2
	CMP / MON	1 / 1
BRC / DPLL	1 / 1	
Timer	GPT12	2
	CCU6	2
STM	Modules	3
FlexRay	Modules	1
	Channels	2

**Table 1-1 Overview of TC27x Functions (cont'd)**

Feature		
CAN	Nodes	4
	Message Objects	256
QSPI	Channels	4
ASCLIN	Interfaces	4
I2C	Interfaces	1
SENT	Channels	10
PSI5	Modules	3
PSI5-S	Modules	1
HSSL	Channels	1
MSC	Channels	2
Ethernet	Channels	1
ASIL	Level	up to ASIL-D
FCE	Modules	1
Safety support	SMU	1
	IOM	1
Security	HSM	1
Embedded Voltage Regulator	DCDC from 5 V / 3.3 V to 1.3 V	Yes
Embedded Voltage Regulator	LDO from 5 V / 3.3 V to 1.3 V	Yes
Embedded Voltage Regulator	LDO from 5 V to 3.3 V	Yes
Low Power Feature	Standby RAM	Yes
Packages	Type	PG-LQFP-176-22 / LF-BGA-292-6 / LF-BGA-292-10
I/O	Type	5 V CMOS / 3.3 V CMOS / LVDS
T <sub>ambient</sub>	Range	-40 ... +125°C

1) Address range starts at lowest address defined in the User's Manual. For reference see the Memory Maps chapter of the User's Manual.

- 2) To ensure the processor cores are provided with a constant stream of instructions the Instruction Fetch Units will speculatively fetch instructions from the up to 64 bytes ahead of the current PC. If the current PC is within 64 bytes of the top of an instruction memory the Instruction Fetch Unit may attempt to speculatively fetch instruction from beyond the physical range. This may then lead to error conditions and alarms being triggered by the bus and memory systems. It is therefore recommended that the upper 64 bytes of any memory be unused for instruction storage.

## **2 Package and Pinning Definitions**

This chapter gives a pinning of the different packages of the TC270 / TC275 / TC277.

Package and Pinning Definitions TC275x Pin Definition and Functions:

2.1 TC275x Pin Definition and Functions: LQFP176

Figure 2-1 is showing the TC275x Logic Symbol for the package variant: QFP176.

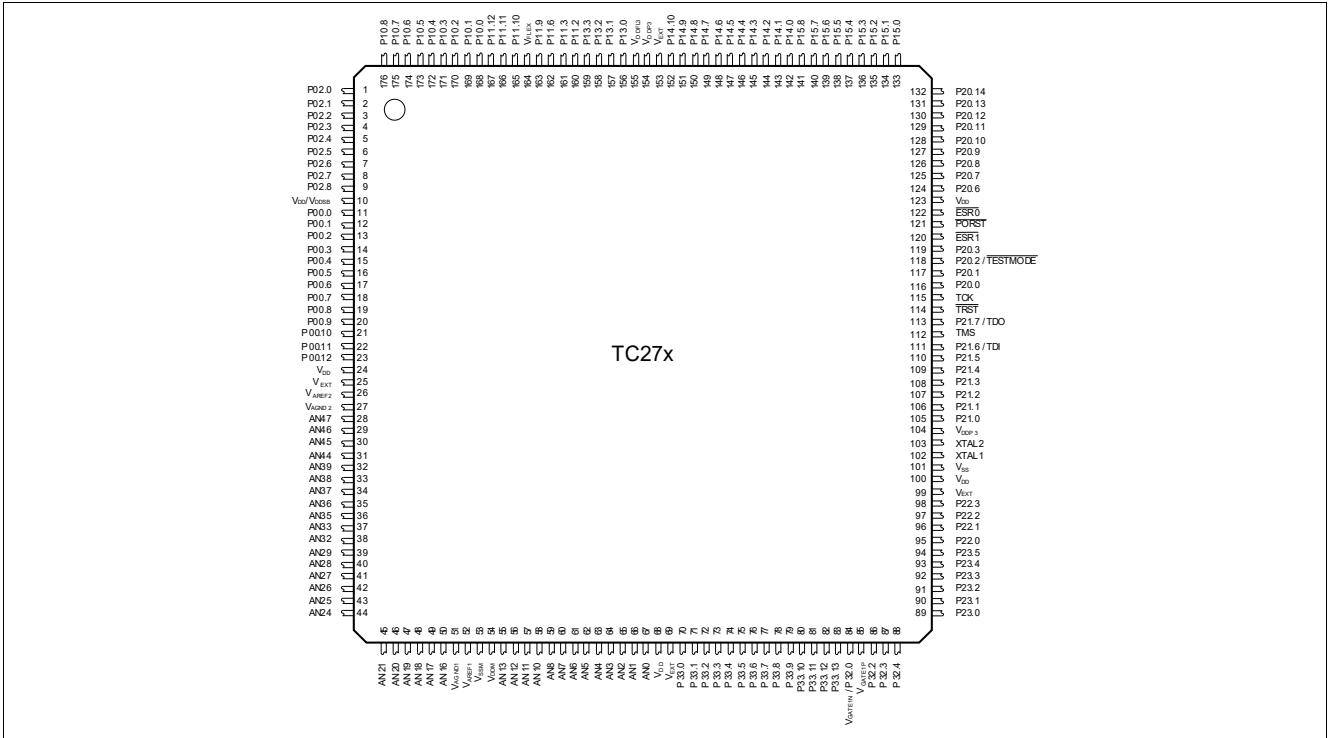

Figure 2-1 TC275x Logic Symbol for the package variant LQFP176.

## 2.1.1 TC275x LQFP176 Package Variant Pin Configuration'

Table 2-1 Port 00 Functions

Pin	Symbol	Ctrl	Type	Function	
11	P00.0	I	MP / PU1 / VEXT	General-purpose input	
	TIN9			GTM input	
	CTRAPA			CCU61 input	
	T12HRE			CCU60 input	
	INJ00			MSC0 input	
	CIFD9			CIF input	
	P00.0	O0		General-purpose output	
	TOUT9	O1		GTM output	
	ASCLK3	O2		ASCLIN3 output	
	ATX3	O3		ASCLIN3 output	
	–	O4		Reserved	
	TXDCAN1	O5		CAN node 1 output	
	–	O6		Reserved	
	COUT63	O7		CCU60 output	
	ETHMDIOA	HWOU T		ETH input/output	
	12	P00.1		I	LP / PU1 / VEXT
TIN10		GTM input			
ARX3E		ASCLIN3 input			
RXDCAN1D		CAN node 1 input			
PSIRX0A		PSI5 input			
SENT0B		SENT input			
CC60INB		CCU60 input			
CC60INA		CCU61 input			
DSCIN5A		DSADC channel 5 input A			
DS5NA		DSADC negative analog input of channel 5, pin A			
VADCG7.5		VADC analog input channel 5 of group 7			
CIFD10		CIF input			
P00.1		O0	General-purpose output		
TOUT10		O1	GTM output		
ATX3		O2	ASCLIN3 output		
–		O3	Reserved		
DSCOUT5	O4	DSADC channel 5 output			
–	O5	Reserved			
SPC0	O6	SENT output			
CC60	O7	CCU61 output			

## Package and Pinning Definitions TC275x Pin Definition and Functions:

Table 2-1 Port 00 Functions (cont'd)

Pin	Symbol	Ctrl	Type	Function	
13	P00.2	I	LP / PU1 / VEXT	General-purpose input	
	TIN11			GTM input	
	SENT1B			SENT input	
	DSDIN5A			DSADC channel 5 input A	
	DS5PA			DSADC positive analog input of channel 5, pin A	
	VADCG7.4			VADC analog input channel 4 of group 7	
	CIFD11			CIF input	
	P00.2			O0	General-purpose output
	TOUT11	O1		GTM output	
	ASCLK3	O2		ASCLIN3 output	
	–	O3		Reserved	
	PSITX0	O4		PSI5 output	
	TXDCAN3	O5		CAN node 3 output	
	–	O6		Reserved	
	COOUT60	O7		CCU61 output	
	14	P00.3		I	LP / PU1 / VEXT
TIN12		GTM input			
RXDCAN3A		CAN node 3 input			
PSIRX1A		PSI5 input			
PSISRXA		PSI5-S input			
SENT2B		SENT input			
CC61INB		CCU60 input			
CC61INA		CCU61 input			
DSCIN3A		DSADC channel 3 input A			
VADCG7.3		VADC analog input channel 3 of group 7			
DSITR5F		DSADC channel 5 input F			
CIFD12		CIF input			
P00.3		O0	General-purpose output		
TOUT12		O1	GTM output		
ASLSO3		O2	ASCLIN3 output		
–		O3	Reserved		
DSCOUT3		O4	DSADC channel 3 output		
–		O5	Reserved		
SPC2		O6	SENT output		
CC61		O7	CCU61 output		

## Package and Pinning Definitions TC275x Pin Definition and Functions:

Table 2-1 Port 00 Functions (cont'd)

Pin	Symbol	Ctrl	Type	Function
15	P00.4	I	LP / PU1 / VEXT	General-purpose input
	TIN13			GTM input
	REQ7			SCU input
	SENT3B			SENT input
	DSDIN3A			DSADC channel 3 input A
	DSSGNA			DSADC input
	VADCG7.2			VADC analog input channel 2 of group 7 (MD)
	CIFD13			CIF input
	P00.4	O0		General-purpose output
	TOUT13	O1		GTM output
	PSISTX	O2		PSI5-S output
	–	O3		Reserved
	PSITX1	O4		PSI5 output
	VADCG4BFL0	O5		VADC output
	SPC3	O6		SENT output
	COU61	O7		CCU61 output
16	P00.5	I	LP / PU1 / VEXT	General-purpose input
	TIN14			GTM input
	PSIRX2A			PSI5 input
	SENT4B			SENT input
	CC62INB			CCU60 input
	CC62INA			CCU61 input
	DSCIN2A			DSADC channel 2 input A
	VADCG7.1			VADC analog input channel 1 of group 7 (MD)
	CIFD14	CIF input		
	P00.5	O0		General-purpose output
	TOUT14	O1		GTM output
	DSCGPWMN	O2		DSADC output
	–	O3		Reserved
	DSCOUT2	O4		DSADC channel 2 output
	VADCG4BFL1	O5		VADC output
	SPC4	O6		SENT output
CC62	O7	CCU61 output		

**Package and Pinning Definitions TC275x Pin Definition and Functions:**
**Table 2-1 Port 00 Functions (cont'd)**

Pin	Symbol	Ctrl	Type	Function	
17	P00.6	I	<b>LP / PU1 / VEXT</b>	General-purpose input	
	TIN15			GTM input	
	SENT5B			SENT input	
	DSDIN2A			DSADC channel 2 input A	
	VADCG7.0			VADC analog input channel 0 of group 7	
	DSITR4F			DSADC channel 4 input F	
	CIFD15			CIF input	
	P00.6	O0		General-purpose output	
	TOUT15	O1		GTM output	
	DSCGPWMP	O2		DSADC output	
	VADCG4BFL2	O3		VADC output	
	PSITX2	O4		PSI5 output	
	VADCEMUX10	O5		VADC output	
	SPC5	O6		SENT output	
	COUT62	O7		CCU61 output	
18	P00.7	I	<b>LP / PU1 / VEXT</b>	General-purpose input	
	TIN16			GTM input	
	SENT6B			SENT input	
	CC60INC			CCU61 input	
	CCPOS0A			CCU61 input	
	T12HRB			CCU60 input	
	T2INA			GPT120 input	
	DSCIN4A			DSADC channel 4 input A	
	DS4NA			DSADC negative analog input of channel 4, pin A	
	VADCG6.5			VADC analog input channel 5 of group 6	
	CIFCLK			CIF input	
	P00.7			O0	General-purpose output
	TOUT16			O1	GTM output
	–	O2		Reserved	
	VADCG4BFL3	O3		VADC output	
	DSCOUT4	O4		DSADC channel 4 output	
	VADCEMUX11	O5		VADC output	
	SPC6	O6		SENT output	
	CC60	O7		CCU61 output	

## Package and Pinning Definitions TC275x Pin Definition and Functions:

Table 2-1 Port 00 Functions (cont'd)

Pin	Symbol	Ctrl	Type	Function
19	P00.8	I	LP / PU1 / VEXT	General-purpose input
	TIN17			GTM input
	SENT7B			SENT input
	CC61INC			CCU61 input
	CCPOS1A			CCU61 input
	T13HRB			CCU60 input
	T2EUDA			GPT120 input
	DSDIN4A			DSADC channel 4 input A
	DS4PA			DSADC channel 4 input A
	VADCG6.4			VADC analog input channel 4 of group 6
	CIFVSNC			CIF input
	P00.8			O0
	TOUT17	O1	GTM output	
	SLSO36	O2	QSPI3 output	
	–	O3	Reserved	
	–	O4	Reserved	
	VADCEMUX12	O5	VADC output	
	SPC7	O6	SENT output	
	CC61	O7	CCU61 output	

## Package and Pinning Definitions TC275x Pin Definition and Functions:

Table 2-1 Port 00 Functions (cont'd)

Pin	Symbol	Ctrl	Type	Function
20	P00.9	I	LP / PU1 / VEXT	General-purpose input
	TIN18			GTM input
	SENT8B			SENT input
	CC62INC			CCU61 input
	CCPOS2A			CCU61 input
	T13HRC			CCU60 input
	T12HRC			CCU60 input
	T4EUDA			GPT120 input
	DSCIN1A			DSADC channel 1 input A
	VADCG6.3			VADC analog input channel 3 of group 6
	DSITR3F			DSADC channel 3 input F
	CIFHSNC			CIF input
	P00.9			O0
	TOUT18	O1	GTM output	
	SLSO37	O2	QSPI3 output	
	ARTS3	O3	ASCLIN3 output	
	DSCOUT1	O4	DSADC channel 1 output	
	–	O5	Reserved	
	SPC8	O6	SENT output	
CC62	O7	CCU61 output		
21	P00.10	I	LP / PU1 / VEXT	General-purpose input
	TIN19			GTM input
	SENT9B			SENT input
	DSDIN1A			DSADC channel 1 input A
	VADCG6.2			VADC analog input channel 2 of group 6 (MD)
	P00.10	O0	General-purpose output	
	TOUT19	O1	GTM output	
	–	O2	Reserved	
	–	O3	Reserved	
	–	O4	Reserved	
	–	O5	Reserved	
	SPC9	O6	SENT output	
	COU63	O7	CCU61 output	

## Package and Pinning Definitions TC275x Pin Definition and Functions:

Table 2-1 Port 00 Functions (cont'd)

Pin	Symbol	Ctrl	Type	Function
22	P00.11	I	LP / PU1 / VEXT	General-purpose input
	TIN20			GTM input
	CTRAPA			CCU60 input
	T12HRE			CCU61 input
	DSCIN0A			DSADC channel 0 input A
	VADCG6.1			VADC analog input channel 1 of group 6 (MD)
	P00.11			O0
	TOUT20	O1		GTM output
	—	O2		Reserved
	—	O3		Reserved
	DSCOUT0	O4		DSADC channel 0 output
	—	O5		Reserved
	—	O6		Reserved
	—	O7		Reserved
23	P00.12	I	LP / PU1 / VEXT	General-purpose input
	TIN21			GTM input
	ACTS3A			ASCLIN3 input
	DSDIN0A			DSADC channel 0 input A
	VADCG6.0			VADC analog input channel 0 of group 6
	P00.12	O0		General-purpose output
	TOUT21	O1		GTM output
	—	O2		Reserved
	—	O3		Reserved
	—	O4		Reserved
	—	O5		Reserved
	—	O6		Reserved
	COUT63	O7		CCU61 output

## Package and Pinning Definitions TC275x Pin Definition and Functions:

Table 2-2 Port 02 Functions

Pin	Symbol	Ctrl	Type	Function
1	P02.0	I	<b>MP+ / PU1 / VEXT</b>	General-purpose input
	TIN0			GTM input
	ARX2G			ASCLIN2 input
	REQ6			SCU input
	CC60INA			CCU60 input
	CC60INB			CCU61 input
	CIFD0			CIF input
	P02.0			O0
	TOUT0	O1		GTM output
	ATX2	O2		ASCLIN2 output
	SLSO31	O3		QSPI3 output
	DSCGPWMN	O4		DSADC output
	TXDCAN0	O5		CAN node 0 output
	TXDA	O6		ERAY output
	CC60	O7		CCU60 output
	2	P02.1		I
TIN1		GTM input		
REQ14		SCU input		
ARX2B		ASCLIN2 input		
RXDCAN0A		CAN node 0 input		
RXDA2		ERAY input		
CIFD1		CIF input		
P02.1		O0	General-purpose output	
TOUT1		O1	GTM output	
–		O2	Reserved	
SLSO32		O3	QSPI3 output	
DSCGPWMP		O4	DSADC output	
–		O5	Reserved	
–		O6	Reserved	
COUT60		O7	CCU60 output	

## Package and Pinning Definitions TC275x Pin Definition and Functions:

Table 2-2 Port 02 Functions (cont'd)

Pin	Symbol	Ctrl	Type	Function
3	P02.2	I	<b>MP+ / PU1 / VEXT</b>	General-purpose input
	TIN2			GTM input
	CC61INA			CCU60 input
	CC61INB			CCU61 input
	CIFD2			CIF input
	P02.2	O0		General-purpose output
	TOUT2	O1		GTM output
	ATX1	O2		ASCLIN1 output
	SLSO33	O3		QSPI3 output
	PSITX0	O4		PSI5 output
	TXDCAN2	O5		CAN node 2 output
	TXDB	O6		ERAY output
	CC61	O7		CCU60 output
	4	P02.3		I
TIN3		GTM input		
ARX1G		ASCLIN1 input		
RXDCAN2B		CAN node 2 input		
RXDB2		ERAY input		
PSIRX0B		PSI5 input		
DSCIN5B		DSADC channel 5 input B		
SDI11		MSC1 input		
CIFD3		CIF input		
P02.3		O0	General-purpose output	
TOUT3		O1	GTM output	
ASLSO2		O2	ASCLIN2 output	
SLSO34		O3	QSPI3 output	
DSCOUT5		O4	DSADC channel 5 output	
–		O5	Reserved	
–		O6	Reserved	
COUT61		O7	CCU60 output	

## Package and Pinning Definitions TC275x Pin Definition and Functions:

Table 2-2 Port 02 Functions (cont'd)

Pin	Symbol	Ctrl	Type	Function	
5	P02.4	I	<b>MP+ / PU1 / VEXT</b>	General-purpose input	
	TIN4			GTM input	
	SLSI3A			QSPI3 input	
	ECTT1			TTCAN input	
	RXDCAN0D			CAN node 0 input	
	CC62INA			CCU60 input	
	CC62INB			CCU61 input	
	DSDIN5B			DSADC channel 5 input B	
	SDA0A			I2C0 input	
	CIFD4			CIF input	
	P02.4			O0	General-purpose output
	TOUT4			O1	GTM output
	ASCLK2	O2		ASCLIN2 output	
	SLSO30	O3		QSPI3 output	
	PSISCLK	O4		PSI5-S output	
	SDA0	O5		I2C0 output	
	TXENA	O6		ERAY output	
	CC62	O7		CCU60 output	
	6	P02.5		I	<b>MP+ / PU1 / VEXT</b>
TIN5		GTM input			
MRST3A		QSPI3 input			
ECTT2		TTCAN input			
PSIRX1B		PSI5 input			
PSISRXB		PSI5-S input			
SENT3C		SENT input			
DSCIN4B		DSADC channel 4 input B			
SCL0A		I2C0 input			
CIFD5		CIF input			
P02.5		O0	General-purpose output		
TOUT5		O1	GTM output		
TXDCAN0		O2	CAN node 0 output		
MRST3		O3	QSPI3 output		
DSCOUT4		O4	DSADC channel 4 output		
SCL0		O5	I2C0 output		
TXENB		O6	ERAY output		
COU62		O7	CCU60 output		

## Package and Pinning Definitions TC275x Pin Definition and Functions:

Table 2-2 Port 02 Functions (cont'd)

Pin	Symbol	Ctrl	Type	Function
7	P02.6	I	<b>MP / PU1 / VEXT</b>	General-purpose input
	TIN6			GTM input
	M TSR3A			QSPI3 input
	SENT2C			SENT input
	CC60INC			CCU60 input
	CCPOS0A			CCU60 input
	T12HRB			CCU61 input
	T3INA			GPT120 input
	CIFD6			CIF input
	DS DIN4B			DSADC channel 4 input B
	DS ITR5E			DSADC channel 5 input E
	P02.6			O0
	TOUT6	O1	GTM output	
	PSISTX	O2	PSI5-S output	
	M TSR3	O3	QSPI3 output	
	PSITX1	O4	PSI5 output	
	VADCEMUX00	O5	VADC output	
	–	O6	Reserved	
	CC60	O7	CCU60 output	

## Package and Pinning Definitions TC275x Pin Definition and Functions:

Table 2-2 Port 02 Functions (cont'd)

Pin	Symbol	Ctrl	Type	Function		
8	P02.7	I	<b>MP / PU1 / VEXT</b>	General-purpose input		
	TIN7			GTM input		
	SCLK3A			QSPI3 input		
	PSIRX2B			PSI5 input		
	SENT1C			SENT input		
	CC61INC			CCU60 input		
	CCPOS1A			CCU60 input		
	T13HRB			CCU61 input		
	T3EUDA			GPT120 input		
	CIFD7			CIF input		
	DSCIN3B			DSADC channel 3 input B		
	DSITR4E			DSADC channel 4 input E		
	P02.7			O0		General-purpose output
	TOUT7			O1		GTM output
	–	O2		Reserved		
	SCLK3	O3		QSPI3 output		
	DSCOUT3	O4		DSADC channel 3 output		
	VADCEMUX01	O5		VADC output		
	SPC1	O6		SENT output		
	CC61	O7		CCU60 output		

**Package and Pinning Definitions TC275x Pin Definition and Functions:**
**Table 2-2 Port 02 Functions (cont'd)**

Pin	Symbol	Ctrl	Type	Function	
<b>9</b>	P02.8	I	<b>LP / PU1 / VEXT</b>	General-purpose input	
	TIN8			GTM input	
	SENT0C			SENT input	
	CC62INC			CCU60 input	
	CCPOS2A			CCU60 input	
	T12HRC			CCU61 input	
	T13HRC			CCU61 input	
	T4INA			GPT120 input	
	CIFD8			CIF input	
	DSDIN3B			DSADC channel 3 input B	
	DSITR3E			DSADC channel 3 input E	
	P02.8			O0	General-purpose output
	TOUT8			O1	GTM output
	SLSO35	O2	QSPI3 output		
	–	O3	Reserved		
	PSITX2	O4	PSI5 output		
	VADCEMUX02	O5	VADC output		
	ETHMDC	O6	ETH output		
	CC62	O7	CCU60 output		

**Table 2-3 Port 10 Functions**

Pin	Symbol	Ctrl	Type	Function
<b>168</b>	P10.0	I	<b>LP / PU1 / VEXT</b>	General-purpose input
	TIN102			GTM input
	T6EUDB			GPT120 input
	P10.0	O0		General-purpose output
	TOUT102	O1		GTM output
	–	O2		Reserved
	SLSO110	O3		QSPI1 output
	–	O4		Reserved
	VADCG6BFL0	O5		VADC output
	–	O6		Reserved
	–	O7		Reserved

## Package and Pinning Definitions TC275x Pin Definition and Functions:

Table 2-3 Port 10 Functions (cont'd)

Pin	Symbol	Ctrl	Type	Function
169	P10.1	I	<b>MP+ / PU1 / VEXT</b>	General-purpose input
	TIN103			GTM input
	MRST1A			QSPI1 input
	T5EUDB			GPT120 input
	P10.1	O0		General-purpose output
	TOUT103	O1		GTM output
	MTRSR1	O2		QSPI1 output
	MRST1	O3		QSPI1 output
	EN01	O4		MSC0 output
	VADCG6BFL1	O5		VADC output
	END03	O6		MSC0 output
	-	O7		Reserved
	170	P10.2		I
TIN104		GTM input		
SCLK1A		QSPI1 input		
T6INB		GPT120 input		
REQ2		SCU input		
RXDCAN2E		CAN node 2 input		
SDI01		MSC0 input		
P10.2		O0	General-purpose output	
TOUT104		O1	GTM output	
-		O2	Reserved	
SCLK1		O3	QSPI1 output	
EN00		O4	MSC0 output	
VADCG6BFL2		O5	VADC output	
END02		O6	MSC0 output	
-		O7	Reserved	

## Package and Pinning Definitions TC275x Pin Definition and Functions:

Table 2-3 Port 10 Functions (cont'd)

Pin	Symbol	Ctrl	Type	Function
171	P10.3	I	<b>MP / PU1 / VEXT</b>	General-purpose input
	TIN105			GTM input
	MTRSR1A			QSPI1 input
	REQ3			SCU input
	T5INB			GPT120 input
	P10.3	O0		General-purpose output
	TOUT105	O1		GTM output
	VADCG6BFL3	O2		VADC output
	MTRSR1	O3		QSPI1 output
	EN00	O4		MSC0 output
	END02	O5		MSC0 output
	TXDCAN2	O6		CAN node 2 output
	-	O7		Reserved
	172	P10.4		I
TIN106		GTM input		
MTRSR1C		QSPI1 input		
CCPOS0C		CCU60 input		
T3INB		GPT120 input		
P10.4		O0	General-purpose output	
TOUT106		O1	GTM output	
-		O2	Reserved	
SLSO18		O3	QSPI1 output	
MTRSR1		O4	QSPI1 output	
EN00		O5	MSC0 output	
END02		O6	MSC0 output	
-		O7	Reserved	
173		P10.5	I	<b>LP / PU1 / VEXT</b>
	TIN107	GTM input		
	HWCFG4	SCU input		
	INJ01	MSC0 input		
	P10.5	O0		
	TOUT107	O1	GTM output	
	ATX2	O2	ASCLIN2 output	
	SLSO38	O3	QSPI3 output	
	SLSO19	O4	QSPI1 output	
	T6OUT	O5	GPT120 output	
	ASLSO2	O6	ASCLIN2 output	
	-	O7	Reserved	

## Package and Pinning Definitions TC275x Pin Definition and Functions:

Table 2-3 Port 10 Functions (cont'd)

Pin	Symbol	Ctrl	Type	Function
174	P10.6	I	LP / PU1 / VEXT	General-purpose input
	TIN108			GTM input
	ARX2D			ASCLIN2 input
	MTR3B			QSPI3 input
	HWCFG5			SCU input
	P10.6	O0		General-purpose output
	TOUT108	O1		GTM output
	ASCLK2	O2		ASCLIN2 output
	MTR3	O3		QSPI3 output
	T3OUT	O4		GPT120 output
	-	O5		Reserved
	MRST1	O6		QSPI1 output
	VADCG7BFL0	O7		VADC output
	175	P10.7		I
TIN109		GTM input		
ACTS2A		ASCLIN2 input		
MRST3B		QSPI3 input		
REQ4		SCU input		
CCPOS1C		CCU60 input		
T3EUDB		GPT120 input		
P10.7		O0	General-purpose output	
TOUT109		O1	GTM output	
-		O2	Reserved	
MRST3		O3	QSPI3 output	
VADCG7BFL1		O4	VADC output	
-		O5	Reserved	
-		O6	Reserved	
-	O7	Reserved		

**Package and Pinning Definitions TC275x Pin Definition and Functions:**
**Table 2-3 Port 10 Functions (cont'd)**

Pin	Symbol	Ctrl	Type	Function
176	P10.8	I	<b>LP / PU1 / VEXT</b>	General-purpose input
	TIN110			GTM input
	SCLK3B			QSPI3 input
	REQ5			SCU input
	CCPOS2C			CCU60 input
	T4INB			GPT120 input
	P10.8			O0
	TOUT110	O1		GTM output
	ARTS2	O2		ASCLIN2 output
	SCLK3	O3		QSPI3 output
	–	O4		Reserved
	–	O5		Reserved
	–	O6		Reserved
	–	O7		Reserved

**Table 2-4 Port 11 Functions**

Pin	Symbol	Ctrl	Type	Function
160	P11.2	I	<b>MPR / PU1 / VFLEX</b>	General-purpose input
	TIN95			GTM input
	P11.2	O0		General-purpose output
	TOUT95	O1		GTM output
	END03	O2		MSC0 output
	SLSO05	O3		QSPI0 output
	SLSO15	O4		QSPI1 output
	EN01	O5		MSC0 output
	ETHTXD1	O6		ETH output
	COU63	O7		CCU60 output

## Package and Pinning Definitions TC275x Pin Definition and Functions:

Table 2-4 Port 11 Functions (cont'd)

Pin	Symbol	Ctrl	Type	Function
161	P11.3	I	MPR / PU1 / VFLEX	General-purpose input
	TIN96			GTM input
	MRST1B			QSPI1 input
	SDI03			MSC0 input
	P11.3	O0		General-purpose output
	TOUT96	O1		GTM output
	–	O2		Reserved
	MRST1	O3		QSPI1 output
	TXDA	O4		ERAY output
	–	O5		Reserved
	ETHTXD0	O6		ETH output
	COU62	O7		CCU60 output
162	P11.6	I	MPR / PU1 / VFLEX	General-purpose input
	TIN97			GTM input
	SCLK1B			QSPI1 input
	P11.6			General-purpose output
	TOUT97	O1		GTM output
	TXENB	O2		ERAY output
	SCLK1	O3		QSPI1 output
	TXENA	O4		ERAY output
	FCLP0	O5		MSC0 output
	ETHTXEN	O6		ETH output
	COU61	O7		CCU60 output
	163	P11.9		I
TIN98		GTM input		
MTR1B		QSPI1 input		
RXDA1		ERAY input		
ETHRXD1		ETH input		
P11.9		O0	General-purpose output	
TOUT98		O1	GTM output	
–		O2	Reserved	
MTR1		O3	QSPI1 output	
–		O4	Reserved	
SOP0		O5	MSC0 output	
–		O6	Reserved	
COU60		O7	CCU60 output	

## Package and Pinning Definitions TC275x Pin Definition and Functions:

Table 2-4 Port 11 Functions (cont'd)

Pin	Symbol	Ctrl	Type	Function
165	P11.10	I	LP / PU1 / VFLEX	General-purpose input
	TIN99			GTM input
	REQ12			SCU input
	ARX1E			ASCLIN1 input
	SLSI1A			QSPI1 input
	RXDCAN3D			CAN node 3 input
	RXDB1			ERAY input
	ETHRXD0			ETH input
	SDI00			MSC0 input
	P11.10	O0		General-purpose output
	TOUT99	O1		GTM output
	–	O2		Reserved
	SLSO03	O3		QSPI0 output
	SLSO13	O4		QSPI1 output
	–	O5		Reserved
	–	O6		Reserved
	CC62	O7		CCU60 output
166	P11.11	I	MP+ / PU1 / VFLEX	General-purpose input
	TIN100			GTM input
	ETHCRSDVA			ETH input
	ETHRXDVA			ETH input
	ETHCRSB			ETH input
	P11.11	O0		General-purpose output
	TOUT100	O1		GTM output
	END02	O2		MSC0 output
	SLSO04	O3		QSPI0 output
	SLSO14	O4		QSPI1 output
	EN00	O5		MSC0 output
	TXENB	O6		ERAY output
	CC61	O7		CCU60 output

**Package and Pinning Definitions TC275x Pin Definition and Functions:**
**Table 2-4 Port 11 Functions (cont'd)**

Pin	Symbol	Ctrl	Type	Function
167	P11.12	I	MPR / PU1 / VFLEX	General-purpose input
	TIN101			GTM input
	ETHREFCLK			ETH input
	ETHTXCLKB			ETH input (Not for productive purposes)
	ETHRXCLKA			ETH input (Not for productive purposes)
	P11.12	O0		General-purpose output
	TOUT101	O1		GTM output
	ATX1	O2		ASCLIN1 output
	GTMCLK2	O3		GTM output
	TXDB	O4		ERAY output
	TXDCAN3	O5		CAN node 3 output
	EXTCLK1	O6		SCU output
	CC60	O7		CCU60 output

**Table 2-5 Port 13 Functions**

Pin	Symbol	Ctrl	Type	Function
156	P13.0	I	LVDSM_N / PU1 / VEXT	General-purpose input
	TIN91			GTM input
	P13.0	O0		General-purpose output
	TOUT91	O1		GTM output
	END03	O2		MSC0 output
	SCLK2N	O3		QSPI2 output (LVDS)
	EN01	O4		MSC0 output
	FCLN0	O5		MSC0 output (LVDS)
	FCLND0	O6		MSC0 output (LVDS)
	–	O7		Reserved
157	P13.1	I	LVDSM_P / PU1 / VEXT	General-purpose input
	TIN92			GTM input
	SCL0B	I		I2C0 input
	P13.1			O0
	TOUT92	O1		GTM output
	–	O2		Reserved
	SCLK2P	O3		QSPI2 output (LVDS)
	–	O4		Reserved
	FCLP0	O5		MSC0 output (LVDS)
	SCL0	O6		I2C0 output
	–	O7		Reserved

**Package and Pinning Definitions TC275x Pin Definition and Functions:**
**Table 2-5 Port 13 Functions (cont'd)**

Pin	Symbol	Ctrl	Type	Function
158	P13.2	I	LVDSM_N / PU1 / VEXT	General-purpose input
	TIN93			GTM input
	CAPINA			GPT120 input
	SDA0B			I2C0 input
	P13.2	O0		General-purpose output
	TOUT93	O1		GTM output
	–	O2		Reserved
	MTSR2N	O3		QSPI2 output (LVDS)
	FCLP0	O4		MSC0 output
	SON0	O5		MSC0 output (LVDS)
	SDA0	O6		I2C0 output
	SOND0	O7		MSC0 output (LVDS)
159	P13.3	I	LVDSM_P / PU1 / VEXT	General-purpose input
	TIN94			GTM input
	P13.3	O0		General-purpose output
	TOUT94	O1		GTM output
	–	O2		Reserved
	MTSR2P	O3		QSPI2 output (LVDS)
	–	O4		Reserved
	SOP0	O5		MSC0 output (LVDS)
	–	O6		Reserved
	–	O7		Reserved

**Table 2-6 Port 14 Functions**

Pin	Symbol	Ctrl	Type	Function
142	P14.0	I	MP+ / PU1 / VEXT	General-purpose input
	TIN80			GTM input
	P14.0	O0		General-purpose output
	TOUT80	O1		GTM output
	ATX0	O2		ASCLIN0 output Recommended as Boot loader pin.
	TXDA	O3		ERAY output
	TXDB	O4		ERAY output
	TXDCAN1	O5		CAN node 1 output Used for single pin DAP (SPD) function.
	ASCLK0	O6		ASCLIN0 output
	COU62	O7		CCU60 output

## Package and Pinning Definitions TC275x Pin Definition and Functions:

Table 2-6 Port 14 Functions (cont'd)

Pin	Symbol	Ctrl	Type	Function
143	P14.1	I	MP / PU1 / VEXT	General-purpose input
	TIN81			GTM input
	REQ15			SCU input
	ARX0A			ASCLIN0 input Recommended as Boot loader pin.
	RXDCAN1B			CAN node 1 input Used for single pin DAP (SPD) function.
	RXDA3			ERAY input
	RXDB3			ERAY input
	EVRWUPA			SCU input
	P14.1			O0
	TOUT81	O1		GTM output
	ATX0	O2		ASCLIN0 output
	–	O3		Reserved
	–	O4		Reserved
	–	O5		Reserved
	–	O6		Reserved
	COUT63	O7		CCU60 output
144	P14.2	I	LP / PU1 / VEXT	General-purpose input
	TIN82			GTM input
	HWCFG2 EVR13			SCU input Latched at cold power on reset to decide EVR13 activation.
	P14.2			O0
	TOUT82	O1		GTM output
	ATX2	O2		ASCLIN2 output
	SLSO21	O3		QSPI2 output
	–	O4		Reserved
	–	O5		Reserved
	ASCLK2	O6		ASCLIN2 output
	–	O7		Reserved

## Package and Pinning Definitions TC275x Pin Definition and Functions:

Table 2-6 Port 14 Functions (cont'd)

Pin	Symbol	Ctrl	Type	Function
145	P14.3	I	LP / PU1 / VEXT	General-purpose input
	TIN83			GTM input
	ARX2A			ASCLIN2 input
	REQ10			SCU input
	HWCFG3_BMI			SCU input
	SDI02			MSC0 input
	P14.3			O0
	TOUT83	O1		GTM output
	ATX2	O2		ASCLIN2 output
	SLSO23	O3		QSPI2 output
	ASLSO1	O4		ASCLIN1 output
	ASLSO3	O5		ASCLIN3 output
	–	O6		Reserved
	–	O7		Reserved
146	P14.4	I	LP / PU1 / VEXT	General-purpose input
	TIN84			GTM input
	HWCFG6			SCU input Latched at cold power on reset to decide default pad reset state (PU or HighZ).
	P14.4	O0		General-purpose output
	TOUT84	O1		GTM output
	–	O2		Reserved
	–	O3		Reserved
	–	O4		Reserved
	–	O5		Reserved
	–	O6		Reserved
–	O7	Reserved		

## Package and Pinning Definitions TC275x Pin Definition and Functions:

Table 2-6 Port 14 Functions (cont'd)

Pin	Symbol	Ctrl	Type	Function
147	P14.5	I	<b>MP+ / PU1 / VEXT</b>	General-purpose input
	TIN85			GTM input
	HWCFG1 EVR33			SCU input Latched at cold power on reset to decide EVR33 activation.
	P14.5	O0		General-purpose output
	TOUT85	O1		GTM output
	—	O2		Reserved
	—	O3		Reserved
	—	O4		Reserved
	—	O5		Reserved
	TXDB	O6		ERAY output
—	O7	Reserved		
148	P14.6	I	<b>MP+ / PU1 / VEXT</b>	General-purpose input
	TIN86			GTM input
	HWCFG0 DCLDO			SCU input If EVR13 active, latched at cold power on reset to decide between LDO and SMPS mode.
	P14.6	O0		General-purpose output
	TOUT86	O1		GTM output
	—	O2		Reserved
	SLSO22	O3		QSPI2 output
	—	O4		Reserved
	—	O5		Reserved
	TXENB	O6		ERAY output
—	O7	Reserved		
149	P14.7	I	<b>LP / PU1 / VEXT</b>	General-purpose input
	TIN87			GTM input
	RXDB0			ERAY input
	P14.7	O0		General-purpose output
	TOUT87	O1		GTM output
	ARTS0	O2		ASCLIN0 output
	SLSO24	O3		QSPI2 output
	—	O4		Reserved
	—	O5		Reserved
	—	O6		Reserved
—	O7	Reserved		

## Package and Pinning Definitions TC275x Pin Definition and Functions:

Table 2-6 Port 14 Functions (cont'd)

Pin	Symbol	Ctrl	Type	Function
150	P14.8	I	LP / PU1 / VEXT	General-purpose input
	TIN88			GTM input
	ARX1D			ASCLIN1 input
	RXDCAN2D			CAN node 2 input
	RXDA0			ERAY input
	P14.8	O0		General-purpose output
	TOUT88	O1		GTM output
	–	O2		Reserved
	–	O3		Reserved
	–	O4		Reserved
	–	O5		Reserved
	–	O6		Reserved
	–	O7		Reserved
151	P14.9	I	MP+ / PU1 / VEXT	General-purpose input
	TIN89			GTM input
	ACTS0A			ASCLIN0 input
	P14.9	O0		General-purpose output
	TOUT89	O1		GTM output
	END03	O2		MSC0 output
	EN01	O3		MSC0 output
	–	O4		Reserved
	$\overline{\text{TXENB}}$	O5		ERAY output
	$\overline{\text{TXENA}}$	O6		ERAY output
	–	O7		Reserved
152	P14.10	I	MP+ / PU1 / VEXT	General-purpose input
	TIN90			GTM input
	P14.10	O0		General-purpose output
	TOUT90	O1		GTM output
	END02	O2		MSC0 output
	EN00	O3		MSC0 output
	ATX1	O4		ASCLIN1 output
	TXDCAN2	O5		CAN node 2 output
	TXDA	O6		ERAY output
	–	O7		Reserved

## Package and Pinning Definitions TC275x Pin Definition and Functions:

Table 2-7 Port 15 Functions

Pin	Symbol	Ctrl	Type	Function
133	P15.0	I	LP / PU1 / VEXT	General-purpose input
	TIN71			GTM input
	P15.0	O0		General-purpose output
	TOUT71	O1		GTM output
	ATX1	O2		ASCLIN1 output
	SLSO013	O3		QSPI0 output
	–	O4		Reserved
	TXDCAN2	O5		CAN node 2 output
	ASCLK1	O6		ASCLIN1 output
	–	O7		Reserved
134	P15.1	I	LP / PU1 / VEXT	General-purpose input
	TIN72			GTM input
	REQ16			SCU input
	ARX1A			ASCLIN1 input
	RXDCAN2A			CAN node 2 input
	SLSI2B			QSPI2 input
	EVRWUPB			SCU input
	P15.1			O0
	TOUT72	O1		GTM output
	ATX1	O2		ASCLIN1 output
	SLSO25	O3		QSPI2 output
	–	O4		Reserved
	–	O5		Reserved
	–	O6		Reserved
	–	O7		Reserved
135	P15.2	I	MP / PU1 / VEXT	General-purpose input
	TIN73			GTM input
	SLSI2A			QSPI2 input
	MRST2E			QSPI2 input
	P15.2	O0		General-purpose output
	TOUT73	O1		GTM output
	ATX0	O2		ASCLIN0 output
	SLSO20	O3		QSPI2 output
	–	O4		Reserved
	TXDCAN1	O5		CAN node 1 output
	ASCLK0	O6		ASCLIN0 output
	–	O7		Reserved

## Package and Pinning Definitions TC275x Pin Definition and Functions:

Table 2-7 Port 15 Functions (cont'd)

Pin	Symbol	Ctrl	Type	Function
136	P15.3	I	MP / PU1 / VEXT	General-purpose input
	TIN74			GTM input
	ARX0B			ASCLIN0 input
	SCLK2A			QSPI2 input
	RXDCAN1A			CAN node 1 input
	P15.3	O0		General-purpose output
	TOUT74	O1		GTM output
	ATX0	O2		ASCLIN0 output
	SCLK2	O3		QSPI2 output
	END03	O4		MSC0 output
	EN01	O5		MSC0 output
	–	O6		Reserved
	–	O7		Reserved
	137	P15.4		I
TIN75		GTM input		
MRST2A		QSPI2 input		
REQ0		SCU input		
SCL0C		I2C0 input		
P15.4		O0	General-purpose output	
TOUT75		O1	GTM output	
ATX1		O2	ASCLIN1 output	
MRST2		O3	QSPI2 output	
–		O4	Reserved	
–		O5	Reserved	
SCL0		O6	I2C0 output	
CC62		O7	CCU60 output	

## Package and Pinning Definitions TC275x Pin Definition and Functions:

Table 2-7 Port 15 Functions (cont'd)

Pin	Symbol	Ctrl	Type	Function
138	P15.5	I	MP / PU1 / VEXT	General-purpose input
	TIN76			GTM input
	ARX1B			ASCLIN1 input
	MTSR2A			QSPI2 input
	REQ13			SCU input
	SDA0C			I2C0 input
	P15.5			O0
	TOUT76	O1		GTM output
	ATX1	O2		ASCLIN1 output
	MTSR2	O3		QSPI2 output
	END02	O4		MSC0 output
	EN00	O5		MSC0 output
	SDA0	O6		I2C0 output
	CC61	O7		CCU60 output
139	P15.6	I	MP / PU1 / VEXT	General-purpose input
	TIN77			GTM input
	MTSR2B			QSPI2 input
	P15.6	O0		General-purpose output
	TOUT77	O1		GTM output
	ATX3	O2		ASCLIN3 output
	MTSR2	O3		QSPI2 output
	–	O4		Reserved
	SCLK2	O5		QSPI2 output
	ASCLK3	O6		ASCLIN3 output
CC60	O7	CCU60 output		
140	P15.7	I	MP / PU1 / VEXT	General-purpose input
	TIN78			GTM input
	ARX3A			ASCLIN3 input
	MRST2B			QSPI2 input
	P15.7	O0		General-purpose output
	TOUT78	O1		GTM output
	ATX3	O2		ASCLIN3 output
	MRST2	O3		QSPI2 output
	–	O4		Reserved
	–	O5		Reserved
	–	O6		Reserved
	COUT60	O7		CCU60 output

## Package and Pinning Definitions TC275x Pin Definition and Functions:

Table 2-7 Port 15 Functions (cont'd)

Pin	Symbol	Ctrl	Type	Function
141	P15.8	I	MP / PU1 / VEXT	General-purpose input
	TIN79			GTM input
	SCLK2B			QSPI2 input
	REQ1			SCU input
	P15.8	O0		General-purpose output
	TOUT79	O1		GTM output
	–	O2		Reserved
	SCLK2	O3		QSPI2 output
	–	O4		Reserved
	–	O5		Reserved
	ASCLK3	O6		ASCLIN3 output
	COU61	O7		CCU60 output

Table 2-8 Port 20 Functions

Pin	Symbol	Ctrl	Type	Function
116	P20.0	I	MP / PU1 / VEXT	General-purpose input
	TIN59			GTM input
	RXDCAN3C			CAN node 3 input
	T6EUDA			GPT120 input
	REQ9			SCU input
	SYSCLK			HSCT input
	TGI0			OCDS input
	P20.0			O0
	TOUT59	O1		GTM output
	ATX3	O2		ASCLIN3 output
	ASCLK3	O3		ASCLIN3 output
	–	O4		Reserved
	SYSCLK	O5		HSCT output
	–	O6		Reserved
	–	O7		Reserved
	TGO0	HWOUT		OCDS; ENx

## Package and Pinning Definitions TC275x Pin Definition and Functions:

Table 2-8 Port 20 Functions (cont'd)

Pin	Symbol	Ctrl	Type	Function
117	P20.1	I	LP / PU1 / VEXT	General-purpose input
	TIN60			GTM input
	TGI1			OCDS input
	P20.1	O0		General-purpose output
	TOUT60	O1		GTM output
	—	O2		Reserved
	—	O3		Reserved
	—	O4		Reserved
	—	O5		Reserved
	—	O6		Reserved
	—	O7		Reserved
	TGO1	HWOU T		OCDS; ENx
118	P20.2	I	LP / PU / VEXT	General-purpose input This pin is latched at power on reset release to enter test mode.
	TESTMODE			OCDS input
	P20.2	O0		Output function not available
	—	O1		Output function not available
	—	O2		Output function not available
	—	O3		Output function not available
	—	O4		Output function not available
	—	O5		Output function not available
	—	O6		Output function not available
	—	O7		Output function not available
119	P20.3	I	LP / PU1 / VEXT	General-purpose input
	TIN61			GTM input
	T6INA			GPT120 input
	ARX3C			ASCLIN3 input
	P20.3	O0		General-purpose output
	TOUT61	O1		GTM output
	ATX3	O2		ASCLIN3 output
	SLSO09	O3		QSPI0 output
	SLSO29	O4		QSPI2 output
	TXDCAN3	O5		CAN node 3 output
	—	O6		Reserved
	—	O7		Reserved

## Package and Pinning Definitions TC275x Pin Definition and Functions:

Table 2-8 Port 20 Functions (cont'd)

Pin	Symbol	Ctrl	Type	Function
124	P20.6	I	LP / PU1 / VEXT	General-purpose input
	TIN62			GTM input
	P20.6	O0		General-purpose output
	TOUT62	O1		GTM output
	ARTS1	O2		ASCLIN1 output
	SLSO08	O3		QSPI0 output
	SLSO28	O4		QSPI2 output
	–	O5		Reserved
	WDT2LCK	O6		SCU output
	–	O7		Reserved
125	P20.7	I	LP / PU1 / VEXT	General-purpose input
	TIN63			GTM input
	ACTS1A			ASCLIN1 input
	RXDCAN0B			CAN node 0 input
	P20.7	O0		General-purpose output
	TOUT63	O1		GTM output
	–	O2		Reserved
	–	O3		Reserved
	–	O4		Reserved
	–	O5		Reserved
	WDT1LCK	O6		SCU output
	COU63	O7		CCU61 output
126	P20.8	I	MP / PU1 / VEXT	General-purpose input
	TIN64			GTM input
	P20.8	O0		General-purpose output
	TOUT64	O1		GTM output
	ASLSO1	O2		ASCLIN1 output
	SLSO00	O3		QSPI0 output
	SLSO10	O4		QSPI1 output
	TXDCAN0	O5		CAN node 0 output
	WDT0LCK	O6		SCU output
	CC60	O7		CCU61 output

## Package and Pinning Definitions TC275x Pin Definition and Functions:

Table 2-8 Port 20 Functions (cont'd)

Pin	Symbol	Ctrl	Type	Function
127	P20.9	I	LP / PU1 / VEXT	General-purpose input
	TIN65			GTM input
	ARX1C			ASCLIN1 input
	RXDCAN3E			CAN node 3 input
	REQ11			SCU input
	SLSI0B			QSPI0 input
	P20.9			O0
	TOUT65	O1		GTM output
	–	O2		Reserved
	SLSO01	O3		QSPI0 output
	SLSO11	O4		QSPI1 output
	–	O5		Reserved
	WDTSLCK	O6		SCU output
	CC61	O7		CCU61 output
128	P20.10	I	MP / PU1 / VEXT	General-purpose input
	TIN66			GTM input
	P20.10	O0		General-purpose output
	TOUT66	O1		GTM output
	ATX1	O2		ASCLIN1 output
	SLSO06	O3		QSPI0 output
	SLSO27	O4		QSPI2 output
	TXDCAN3	O5		CAN node 3 output
	ASCLK1	O6		ASCLIN1 output
	CC62	O7		CCU61 output
129	P20.11	I	MP / PU1 / VEXT	General-purpose input
	TIN67			GTM input
	SCLK0A			QSPI0 input
	P20.11	O0		General-purpose output
	TOUT67	O1		GTM output
	–	O2		Reserved
	SCLK0	O3		QSPI0 output
	–	O4		Reserved
	–	O5		Reserved
	–	O6		Reserved
	COU60	O7		CCU61 output

## Package and Pinning Definitions TC275x Pin Definition and Functions:

Table 2-8 Port 20 Functions (cont'd)

Pin	Symbol	Ctrl	Type	Function
130	P20.12	I	<b>MP / PU1 / VEXT</b>	General-purpose input
	TIN68			GTM input
	MRST0A			QSPI0 input
	P20.12	O0		General-purpose output
	TOUT68	O1		GTM output
	–	O2		Reserved
	MRST0	O3		QSPI0 output
	MTRSR0	O4		QSPI0 output
	–	O5		Reserved
	–	O6		Reserved
COU61	O7	CCU61 output		
131	P20.13	I	<b>MP / PU1 / VEXT</b>	General-purpose input
	TIN69			GTM input
	SLSI0A			QSPI0 input
	P20.13	O0		General-purpose output
	TOUT69	O1		GTM output
	–	O2		Reserved
	SLSO02	O3		QSPI0 output
	SLSO12	O4		QSPI1 output
	SCLK0	O5		QSPI0 output
	–	O6		Reserved
COU62	O7	CCU61 output		
132	P20.14	I	<b>MP / PU1 / VEXT</b>	General-purpose input
	TIN70			GTM input
	MTRSR0A			QSPI0 input
	P20.14	O0		General-purpose output
	TOUT70	O1		GTM output
	–	O2		Reserved
	MTRSR0	O3		QSPI0 output
	–	O4		Reserved
	–	O5		Reserved
	–	O6		Reserved
–	O7	Reserved		

## Package and Pinning Definitions TC275x Pin Definition and Functions:

Table 2-9 Port 21 Functions

Pin	Symbol	Ctrl	Type	Function
105	P21.0	I	A2 / PU1 / VDDP3	General-purpose input
	TIN51			GTM input
	P21.0	O0		General-purpose output
	TOUT51	O1		GTM output
	—	O2		Reserved
	—	O3		Reserved
	—	O4		Reserved
	—	O5		Reserved
	ETHMDC	O6		ETH output
	—	O7		Reserved
	HSM1	HWOUT		HSM output 1
106	P21.1	I	A2 / PU1 / VDDP3	General-purpose input
	TIN52			GTM input
	ETHMDIOB			ETH input (Not for production purposes)
	P21.1	O0		General-purpose output
	TOUT52	O1		GTM output
	—	O2		Reserved
	—	O3		Reserved
	—	O4		Reserved
	—	O5		Reserved
	ETHMDIO	O6		ETH output (Not for production purposes)
	—	O7		Reserved
HSM2	HWOUT	HSM output 2		

## Package and Pinning Definitions TC275x Pin Definition and Functions:

Table 2-9 Port 21 Functions (cont'd)

Pin	Symbol	Ctrl	Type	Function	
107	P21.2	I	LVDSH_N/ PU1 / VDDP3	General-purpose input	
	TIN53			GTM input	
	MRST2CN			QSPI2 input (LVDS)	
	MRST3FN			QSPI3 input (LVDS)	
	ARX3GN			ASCLIN3 input (LVDS)	
	EMGSTOPB			SCU input	
	RXDN			HSCT input (LVDS)	
	P21.2			O0	General-purpose output
	TOUT53	O1		GTM output	
	ASLSO3	O2		ASCLIN3 output	
	–	O3		Reserved	
	–	O4		Reserved	
	ETHMDC	O5		ETH output	
	–	O6		Reserved	
	–	O7		Reserved	
108	P21.3	I	LVDSH_P/ PU1 / VDDP3	General-purpose input	
	TIN54			GTM input	
	MRST2CP			QSPI2 input (LVDS)	
	MRST3FP			QSPI3 input (LVDS)	
	ARX3GP			ASCLIN3 input (LVDS)	
	RXDP			HSCT input (LVDS)	
	P21.3			O0	General-purpose output
	TOUT54			O1	GTM output
	–	O2		Reserved	
	–	O3		Reserved	
	–	O4		Reserved	
	–	O5		Reserved	
	–	O6		Reserved	
	–	O7		Reserved	
	ETHMDIOD	HWOUT		ETH input/output	

**Package and Pinning Definitions TC275x Pin Definition and Functions:**
**Table 2-9 Port 21 Functions (cont'd)**

Pin	Symbol	Ctrl	Type	Function
109	P21.4	I	LVDSH_N/ PU1 / VDDP3	General-purpose input
	TIN55			GTM input
	P21.4	O0		General-purpose output
	TOUT55	O1		GTM output
	–	O2		Reserved
	–	O3		Reserved
	–	O4		Reserved
	–	O5		Reserved
	–	O6		Reserved
	–	O7		Reserved
	TXDN	HSCT		HSCT output (LVDS)
110	P21.5	I	LVDSH_P/ PU1 / VDDP3	General-purpose input
	TIN56			GTM input
	P21.5	O0		General-purpose output
	TOUT56	O1		GTM output
	ASCLK3	O2		ASCLIN3 output
	–	O3		Reserved
	–	O4		Reserved
	–	O5		Reserved
	–	O6		Reserved
	–	O7		Reserved
	TXDP	HSCT		HSCT output (LVDS)
111 <sup>1)</sup>	P21.6	I	A2 / PU / VDDP3	General-purpose input
	TIN57			GTM input
	ARX3F			ASCLIN3 input
	$\overline{\text{TGI2}}$			OCDS input
	TDI			OCDS (JTAG) input
	T5EUDA			GPT120 input
	P21.6	O0		General-purpose output
	TOUT57	O1		GTM output
	ASLSO3	O2		ASCLIN3 output
	–	O3		Reserved
	–	O4		Reserved
	SYSCLK	O5		HSCT output
	–	O6		Reserved
	T3OUT	O7		GPT120 output
	$\overline{\text{TGO2}}$	HWOUT		OCDS; ENx

**Package and Pinning Definitions TC275x Pin Definition and Functions:**
**Table 2-9 Port 21 Functions (cont'd)**

Pin	Symbol	Ctrl	Type	Function
113	P21.7	I	A2 / PU / VDDP3	General-purpose input
	TIN58			GTM input
	DAP2			OCDS input
	TGI3			OCDS input
	TDO			OCDS (JTAG) input The JTAG TDO function is overlaid with P21.7 via a double bond. In JTAG mode this pin is used as TDO, after power-on reset it is HighZ. In DAP mode this pin is used as P21.7 and controlled by the related port control logic
	ETHRXERB			ETH input
	T5INA			GPT120 input
	P21.7			O0
	TOUT58	O1	GTM output	
	ATX3	O2	ASCLIN3 output	
	ASCLK3	O3	ASCLIN3 output	
	–	O4	Reserved	
	–	O5	Reserved	
	–	O6	Reserved	
	T6OUT	O7	GPT120 output	
	TGO3	HWOU T	OCDS; ENx	
	TDO		OCDS (JTAG); ENx The JTAG TDO function is overlaid with P21.7 via a double bond. In JTAG mode this pin is used as TDO, after power-on reset it is HighZ. In DAP mode this pin is used as P21.7 and controlled by the related port control logic	

1) For an Emulation Device in a non Fusion Quad package this pin is used as VDDPSB (3.3V)

**Package and Pinning Definitions TC275x Pin Definition and Functions:**
**Table 2-10 Port 22 Functions**

Pin	Symbol	Ctrl	Type	Function
95	P22.0	I	LVDSM_N / PU1 / VEXT	General-purpose input
	TIN47			GTM input
	MTSR3E			QSPI3 input
	P22.0	O0		General-purpose output
	TOUT47	O1		GTM output
	ATX3N	O2		ASCLIN3 output (LVDS)
	MTSR3	O3		QSPI3 output
	SCLK3N	O4		QSPI3 output (LVDS)
	FCLN1	O5		MSC1 output (LVDS)
	FCLND1	O6		MSC1 output (LVDS)
	–	O7		Reserved
96	P22.1	I	LVDSM_P / PU1 / VEXT	General-purpose input
	TIN48			GTM input
	MRST3E			QSPI3 input
	P22.1	O0		General-purpose output
	TOUT48	O1		GTM output
	ATX3P	O2		ASCLIN3 output (LVDS)
	MRST3	O3		QSPI3 output
	SCLK3P	O4		QSPI3 output (LVDS)
	FCLP1	O5		MSC1 output (LVDS)
	–	O6		Reserved
	–	O7		Reserved
97	P22.2	I	LVDSM_N / PU1 / VEXT	General-purpose input
	TIN49			GTM input
	SLSI3D			QSPI3 input
	P22.2	O0		General-purpose output
	TOUT49	O1		GTM output
	–	O2		Reserved
	SLSO312	O3		QSPI3 output
	MTSR3N	O4		QSPI3 output (LVDS)
	SON1	O5		MSC1 output (LVDS)
	SOND1	O6		MSC1 output (LVDS)
	–	O7		Reserved

## Package and Pinning Definitions TC275x Pin Definition and Functions:

Table 2-10 Port 22 Functions (cont'd)

Pin	Symbol	Ctrl	Type	Function
98	P22.3	I	LVDSM_P / PU1 / VEXT	General-purpose input
	TIN50			GTM input
	SCLK3E			QSPI3 input
	P22.3	O0		General-purpose output
	TOUT50	O1		GTM output
	–	O2		Reserved
	SCLK3	O3		QSPI3 output
	MTRS3P	O4		QSPI3 output (LVDS)
	SOP1	O5		MSC1 output (LVDS)
	–	O6		Reserved
	–	O7		Reserved

Table 2-11 Port 23 Functions

Pin	Symbol	Ctrl	Type	Function
89	P23.0	I	LP / PU1 / VEXT	General-purpose input
	TIN41			GTM input
	P23.0	O0		General-purpose output
	TOUT41	O1		GTM output
	–	O2		Reserved
	–	O3		Reserved
	–	O4		Reserved
	–	O5		Reserved
	–	O6		Reserved
	–	O7		Reserved
90	P23.1	I	MP+ / PU1 / VEXT	General-purpose input
	TIN42			GTM input
	SDI10			MSC1 input
	P23.1	O0		General-purpose output
	TOUT42	O1		GTM output
	ARTS1	O2		ASCLIN1 output
	SLSO313	O3		QSPI3 output
	GTMCLK0	O4		GTM output
	–	O5		Reserved
	EXTCLK0	O6		SCU output
	–	O7		Reserved

## Package and Pinning Definitions TC275x Pin Definition and Functions:

Table 2-11 Port 23 Functions (cont'd)

Pin	Symbol	Ctrl	Type	Function
91	P23.2	I	<b>LP / PU1 / VEXT</b>	General-purpose input
	TIN43			GTM input
	P23.2	O0		General-purpose output
	TOUT43	O1		GTM output
	—	O2		Reserved
	—	O3		Reserved
	—	O4		Reserved
	—	O5		Reserved
	—	O6		Reserved
	—	O7		Reserved
92	P23.3	I	<b>LP / PU1 / VEXT</b>	General-purpose input
	TIN44			GTM input
	INJ10			MSC1 input
	P23.3	O0		General-purpose output
	TOUT44	O1		GTM output
	—	O2		Reserved
	—	O3		Reserved
	—	O4		Reserved
	—	O5		Reserved
	—	O6		Reserved
—	O7	Reserved		
93	P23.4	I	<b>MP+ / PU1 / VEXT</b>	General-purpose input
	TIN45			GTM input
	P23.4	O0		General-purpose output
	TOUT45	O1		GTM output
	—	O2		Reserved
	SLSO35	O3		QSPI3 output
	END12	O4		MSC1 output
	EN10	O5		MSC1 output
	—	O6		Reserved
	—	O7		Reserved

## Package and Pinning Definitions TC275x Pin Definition and Functions:

Table 2-11 Port 23 Functions (cont'd)

Pin	Symbol	Ctrl	Type	Function
94	P23.5	I	<b>MP+ / PU1 / VEXT</b>	General-purpose input
	TIN46			GTM input
	P23.5	O0		General-purpose output
	TOUT46	O1		GTM output
	—	O2		Reserved
	SLSO34	O3		QSPI3 output
	END13	O4		MSC1 output
	EN11	O5		MSC1 output
	—	O6		Reserved
	—	O7		Reserved

Table 2-12 Port 32 Functions

Pin	Symbol	Ctrl	Type	Function
84	P32.0	I	<b>LP / EVR13 SMPS -&gt; PD, GPIO -&gt; PU / VEXT</b>	General-purpose input
	TIN36			GTM input
	FDEST			PMU input
	VGATE1N			SMPS mode: analog output. External Pass Device gate control for EVR13
	P32.0	O0		General-purpose output
	TOUT36	O1		GTM output
	—	O2		Reserved
	—	O3		Reserved
	—	O4		Reserved
	—	O5		Reserved
—	O6	Reserved		
—	O7	Reserved		
86	P32.2	I	<b>LP / PU1 / VEXT</b>	General-purpose input
	TIN38			GTM input
	ARX3D			ASCLIN3 input
	RXD CAN3B			CAN node 3 input
	P32.2	O0		General-purpose output
	TOUT38	O1		GTM output
	ATX3	O2		ASCLIN3 output
	—	O3		Reserved
	—	O4		Reserved
	—	O5		Reserved
DCDCSYNC	O6	SCU output		
—	O7	Reserved		

**Package and Pinning Definitions TC275x Pin Definition and Functions:**
**Table 2-12 Port 32 Functions (cont'd)**

Pin	Symbol	Ctrl	Type	Function
87	P32.3	I	LP / PU1 / VEXT	General-purpose input
	TIN39			GTM input
	P32.3			General-purpose output
	TOUT39	O0		GTM output
	ATX3	O1		ASCLIN3 output
	–	O2		Reserved
	ASCLK3	O3		ASCLIN3 output
	TXDCAN3	O4		CAN node 3 output
	–	O5		Reserved
	–	O6		Reserved
88	P32.4	I	MP+ / PU1 / VEXT	General-purpose input
	TIN40			GTM input
	ACTS1B			ASCLIN1 input
	SDI12			MSC1 input
	P32.4	O0		General-purpose output
	TOUT40	O1		GTM output
	–	O2		Reserved
	END12	O3		MSC1 output
	GTMCLK1	O4		GTM output
	EN10	O5		MSC1 output
	EXTCLK1	O6		SCU output
	COU63	O7		CCU60 output

**Table 2-13 Port 33 Functions**

Pin	Symbol	Ctrl	Type	Function
70	P33.0	I	LP / PU1 / VEXT	General-purpose input
	TIN22			GTM input
	DSITR0E			DSADC channel 0 input E
	P33.0	O0		General-purpose output
	TOUT22	O1		GTM output
	–	O2		Reserved
	–	O3		Reserved
	–	O4		Reserved
	–	O5		Reserved
	VADCG2BFL0	O6		VADC output
	–	O7		Reserved

## Package and Pinning Definitions TC275x Pin Definition and Functions:

Table 2-13 Port 33 Functions (cont'd)

Pin	Symbol	Ctrl	Type	Function
71	P33.1	I	LP / PU1 / VEXT	General-purpose input
	TIN23			GTM input
	PSIRX0C			PSI5 input
	SENT9C			SENT input
	DSCIN2B			DSADC channel 2 input B
	DSITR1E			DSADC channel 1 input E
	P33.1			O0
	TOUT23	O1		GTM output
	ASLSO3	O2		ASCLIN3 output
	–	O3		Reserved
	DSCOUT2	O4		DSADC channel 2 output
	VADCEMUX02	O5		VADC output
	VADCG2BFL1	O6		VADC output
	–	O7		Reserved
72	P33.2	I	LP / PU1 / VEXT	General-purpose input
	TIN24			GTM input
	SENT8C			SENT input
	DSDIN2B			DSADC channel 2 input B
	DSITR2E			DSADC channel 2 input E
	P33.2	O0		General-purpose output
	TOUT24	O1		GTM output
	ASCLK3	O2		ASCLIN3 output
	–	O3		Reserved
	PSITX0	O4		PSI5 output
	VADCEMUX01	O5		VADC output
	VADCG2BFL2	O6		VADC output
	–	O7		Reserved

## Package and Pinning Definitions TC275x Pin Definition and Functions:

Table 2-13 Port 33 Functions (cont'd)

Pin	Symbol	Ctrl	Type	Function
73	P33.3	I	LP / PU1 / VEXT	General-purpose input
	TIN25			GTM input
	PSIRX1C			PSI5 input
	SENT7C			SENT input
	DSCIN1B			DSADC channel 1 input B
	P33.3			O0
	TOUT25	O1		GTM output
	–	O2		Reserved
	–	O3		Reserved
	DSCOUT1	O4		DSADC channel 1 output
	VADCEMUX00	O5		VADC output
	VADCG2BFL3	O6		VADC output
	–	O7		Reserved
	74	P33.4		I
TIN26		GTM input		
SENT6C		SENT input		
CTR $\overline$ APC		CCU61 input		
DSDIN1B		DSADC channel 1 input B		
DSITR0F		DSADC channel 0 input F		
P33.4		O0	General-purpose output	
TOUT26		O1	GTM output	
ARTS2		O2	ASCLIN2 output	
–		O3	Reserved	
PSITX1		O4	PSI5 output	
VADCEMUX12		O5	VADC output	
VADCG0BFL0		O6	VADC output	
–		O7	Reserved	

## Package and Pinning Definitions TC275x Pin Definition and Functions:

Table 2-13 Port 33 Functions (cont'd)

Pin	Symbol	Ctrl	Type	Function
75	P33.5	I	LP / PU1 / VEXT	General-purpose input
	TIN27			GTM input
	ACTS2B			ASCLIN2 input
	PSIRX2C			PSI5 input
	PSISRXC			PSI5-S input
	SENT5C			SENT input
	CCPOS2C			CCU61 input
	T4EADB			GPT120 input
	DSCIN0B			DSADC channel 0 input B
	DSITR1F			DSADC channel 1 input F
	P33.5			O0
	TOUT27	O1		GTM output
	SLSO07	O2		QSPI0 output
	SLSO17	O3		QSPI1 output
	DSCOUT0	O4		DSADC channel 0 output
	VADCEMUX11	O5		VADC output
	VADCG0BFL1	O6		VADC output
	-	O7		Reserved
	76	P33.6		I
TIN28		GTM input		
SENT4C		SENT input		
CCPOS1C		CCU61 input		
T2EADB		GPT120 input		
DSDIN0B		DSADC channel 0 input B		
DSITR2F		DSADC channel 2 input F		
P33.6		O0	General-purpose output	
TOUT28		O1	GTM output	
ASLSO2		O2	ASCLIN2 output	
-		O3	Reserved	
PSITX2		O4	PSI5 output	
VADCEMUX10		O5	VADC output	
VADCG1BFL0		O6	VADC output	
PSISTX		O7	PSI5-S output	

## Package and Pinning Definitions TC275x Pin Definition and Functions:

Table 2-13 Port 33 Functions (cont'd)

Pin	Symbol	Ctrl	Type	Function
77	P33.7	I	LP / PU1 / VEXT	General-purpose input
	TIN29			GTM input
	RXDCAN0E			CAN node 0 input
	REQ8			SCU input
	CCPOS0C			CCU61 input
	T2INB			GPT120 input
	P33.7			O0
	TOUT29	O1		GTM output
	ASCLK2	O2		ASCLIN2 output
	SLSO37	O3		QSPI3 output
	–	O4		Reserved
	–	O5		Reserved
	VADCG1BFL1	O6		VADC output
	–	O7		Reserved
78	P33.8	I	MP / HighZ/ VEXT	General-purpose input
	TIN30			GTM input
	ARX2E			ASCLIN2 input
	EMGSTOPA			SCU input
	P33.8	O0		General-purpose output
	TOUT30	O1		GTM output
	ATX2	O2		ASCLIN2 output
	SLSO32	O3		QSPI3 output
	–	O4		Reserved
	TXDCAN0	O5		CAN node 0 output
	–	O6		Reserved
	COUT62	O7		CCU61 output
	SMUFSP	HWOUT		SMU
79	P33.9	I	LP / PU1 / VEXT	General-purpose input
	TIN31			GTM input
	P33.9	O0		General-purpose output
	TOUT31	O1		GTM output
	ATX2	O2		ASCLIN2 output
	SLSO31	O3		QSPI3 output
	ASCLK2	O4		ASCLIN2 output
	–	O5		Reserved
	–	O6		Reserved
	CC62	O7		CCU61 output

## Package and Pinning Definitions TC275x Pin Definition and Functions:

Table 2-13 Port 33 Functions (cont'd)

Pin	Symbol	Ctrl	Type	Function
80	P33.10	I	<b>MP / PU1 / VEXT</b>	General-purpose input
	TIN32			GTM input
	SLSI3C			QSPI3 input
	P33.10	O0		General-purpose output
	TOUT32	O1		GTM output
	SLSO16	O2		QSPI1 output
	SLSO311	O3		QSPI3 output
	ASLSO1	O4		ASCLIN1 output
	PSISCLK	O5		PSI5-S output
	–	O6		Reserved
	COU61	O7		CCU61 output
81	P33.11	I	<b>MP / PU1 / VEXT</b>	General-purpose input
	TIN33			GTM input
	SCLK3D			QSPI3 input
	P33.11	O0		General-purpose output
	TOUT33	O1		GTM output
	ASCLK1	O2		ASCLIN1 output
	SCLK3	O3		QSPI3 output
	–	O4		Reserved
	–	O5		Reserved
	DSCGPWMN	O6		DSADC output
	CC61	O7		CCU61 output
82	P33.12	I	<b>MP / PU1 / VEXT</b>	General-purpose input
	TIN34			GTM input
	MTSR3D			QSPI3 input
	P33.12	O0		General-purpose output
	TOUT34	O1		GTM output
	ATX1	O2		ASCLIN1 output
	MTSR3	O3		QSPI3 output
	ASCLK1	O4		ASCLIN1 output
	–	O5		Reserved
	DSCGPWMP	O6		DSADC output
	COU60	O7		CCU61 output

**Package and Pinning Definitions TC275x Pin Definition and Functions:**
**Table 2-13 Port 33 Functions (cont'd)**

Pin	Symbol	Ctrl	Type	Function
83	P33.13	I	<b>MP / PU1 / VEXT</b>	General-purpose input
	TIN35			GTM input
	ARX1F			ASCLIN1 input
	MRST3D			QSPI3 input
	DSSGNB			DSADC input
	INJ11			MSC1 input
	P33.13			O0
	TOUT35	O1		GTM output
	ATX1	O2		ASCLIN1 output
	MRST3	O3		QSPI3 output
	SLSO26	O4		QSPI2 output
	–	O5		Reserved
	DCDCSYNC	O6		SCU output
	CC60	O7		CCU61 output

**Table 2-14 Port 40 Functions**

Pin	Symbol	Ctrl	Type	Function
44	P40.0	I	<b>S / HighZ / VDDM</b>	General-purpose input
	VADCG3.0			VADC analog input channel 0 of group 3
	DS2PB			DSADC: positive analog input channel of DSADC 2, pin B
	CCPOS0D			CCU60 input
	SENT0A			SENT input
43	P40.1	I	<b>S / HighZ / VDDM</b>	General-purpose input
	VADCG3.1			VADC analog input channel 1 of group 3 (MD)
	DS2NB			DSADC: negative analog of input channel 2, pin B
	CCPOS1B			CCU60 input
	SENT1A			SENT input
42	P40.2	I	<b>S / HighZ / VDDM</b>	General-purpose input
	VADCG3.2			VADC analog input channel 2 of group 3 (MD)
	CCPOS1D			CCU60 input
	SENT2A			SENT input
41	P40.3	I	<b>S / HighZ / VDDM</b>	General-purpose input
	VADCG3.3			VADC analog input channel 3 of group 3
	CCPOS2B			CCU60 input
	SENT3A			SENT input

**Package and Pinning Definitions TC275x Pin Definition and Functions:**
**Table 2-14 Port 40 Functions (cont'd)**

Pin	Symbol	Ctrl	Type	Function
38	P40.4	I	S / HighZ / VDDM	General-purpose input
	VADCG4.0			VADC analog input channel 0 of group 4
	CCPOS2D			CCU60 input
	SENT4A			SENT input
37	P40.5	I	S / HighZ / VDDM	General-purpose input
	VADCG4.1			VADC analog input channel 1 of group 4 (MD)
	CCPOS0D			CCU61 input
	SENT5A			SENT input
35	P40.6	I	S / HighZ / VDDM	General-purpose input
	VADCG4.4			VADC analog input channel 4 of group 4
	DS3PA			DSADC: positive analog input of channel 3, pin A
	CCPOS1B			CCU61 input
	SENT6A			SENT input
34	P40.7	I	S / HighZ / VDDM	General-purpose input
	VADCG4.5			VADC analog input channel 5 of group 4
	DS3NA			DSADC: negative analog input of channel 3, pin A
	CCPOS1D			CCU61 input
	SENT7A			SENT input
33	P40.8	I	S / HighZ / VDDM	General-purpose input
	VADCG4.6			VADC analog input channel 6 of group 4
	DS3PB			DSADC: positive analog input of channel 3, pin B
	CCPOS2B			CCU61 input
	SENT8A			SENT input
32	P40.9	I	S / HighZ / VDDM	General-purpose input
	VADCG4.7			VADC analog input channel 7 of group 4
	DS3NB			DSADC: negative analog input of channel 3, pin B
	CCPOS2D			CCU61 input
	SENT9A			SENT input

**Table 2-15 Analog Inputs**

Pin	Symbol	Ctrl	Type	Function
67	AN0	I	D / HighZ / VDDM	Analog input 0
	VADCG0.0			VADC analog input channel 0 of group 0
	DS1PA			DSADC: positive analog of input channel 1, pin A
66	AN1	I	D / HighZ / VDDM	Analog input 1
	VADCG0.1			VADC analog input channel 1 of group 0 (MD)
	DS1NA			DSADC: negative analog input of channel 1, pin A

**Package and Pinning Definitions TC275x Pin Definition and Functions:**
**Table 2-15 Analog Inputs (cont'd)**

Pin	Symbol	Ctrl	Type	Function
65	AN2	I	D / HighZ / VDDM	Analog input 2
	VADCG0.2			VADC analog input channel 2 of group 0 (MD)
	DS0PA			DSADC: positive analog input of channel 0, pin A
64	AN3	I	D / HighZ / VDDM	Analog input 3
	VADCG0.3			VADC analog input channel 3 of group 0
	DS0NA			DSADC: negative analog input of channel 0, pin A
63	AN4	I	D / HighZ / VDDM	Analog input 4
	VADCG0.4			VADC analog input channel 4 of group 0
62	AN5	I	D / HighZ / VDDM	Analog input 5
	VADCG0.5			VADC analog input channel 5 of group 0
61	AN6	I	D / HighZ / VDDM	Analog input 6
	VADCG0.6			VADC analog input channel 6 of group 0
60	AN7	I	D / HighZ / VDDM	Analog input 7
	VADCG0.7			VADC analog input channel 7 of group 0 (with pull down diagnostics)
59	AN8	I	D / HighZ / VDDM	Analog input 8
	VADCG1.0			VADC analog input channel 0 of group 1
58	AN10	I	D / HighZ / VDDM	Analog input 10
	VADCG1.2			VADC analog input channel 2 of group 1 (MD)
57	AN11	I	D / HighZ / VDDM	Analog input 11
	VADCG1.3			VADC analog input channel 3 of group 1 (with pull down diagnostics)
56	AN12	I	D / HighZ / VDDM	Analog input 12
	VADCG1.4			VADC analog input channel 4 of group 1
55	AN13	I	D / HighZ / VDDM	Analog input 13
	VADCG1.5			VADC analog input channel 5 of group 1
50	AN16	I	D / HighZ / VDDM	Analog input 16
	VADCG2.0			VADC analog input channel 0 of group 2
49	AN17	I	D / HighZ / VDDM	Analog input 17
	VADCG2.1			VADC analog input channel 1 of group 2 (MD)
48	AN18	I	D / HighZ / VDDM	Analog input 18
	VADCG2.2			VADC analog input channel 2 of group 2 (MD)

**Package and Pinning Definitions TC275x Pin Definition and Functions:**
**Table 2-15 Analog Inputs (cont'd)**

Pin	Symbol	Ctrl	Type	Function
47	AN19	I	D / HighZ / VDDM	Analog input 19
	VADCG2.3			VADC analog input channel 3 of group 2 (with pull down diagnostics)
46	AN20	I	D / HighZ / VDDM	Analog input 20
	VADCG2.4			VADC analog input channel 4 of group 2
	DS2PA			DSADC: positive analog input of channel 2, pin A
45	AN21	I	D / HighZ / VDDM	Analog input 21
	VADCG2.5			VADC analog input channel 5 of group 2
	DS2NA			DSADC: negative analog input of channel of DSADC 2, pin A
44	AN24	I	S / HighZ / VDDM	Analog input 24
	VADCG3.0			VADC analog input channel 0 of group 3
	DS2PB			DSADC: positive analog input of channel 2, pin B
	SENT0A			SENT input channel 0, pin A
43	AN25	I	S / HighZ / VDDM	Analog input 24
	VADCG3.1			VADC analog input channel 1 of group 3 (MD)
	DS2NB			DSADC: negative analog input of channel 2, pin B
	SENT1A			SENT input channel 1, pin A
42	AN26	I	S / HighZ / VDDM	Analog input 26
	VADCG3.2			VADC analog input channel 2 of group 3 (MD)
	SENT2A			SENT input channel 2, pin A
41	AN27	I	S / HighZ / VDDM	Analog input 27
	VADCG3.3			VADC analog input channel 3 of group 3 (with pull down diagnostics)
	SENT3A			SENT input channel 3, pin A
40	AN28	I	D / HighZ / VDDM	Analog input 28
	VADCG3.4			VADC analog input channel 4 of group 3
39	AN29	I	D / HighZ / VDDM	Analog input 29
	VADCG3.5			VADC analog input channel 5 of group 3
38	AN32	I	S / HighZ / VDDM	Analog input 32
	VADCG4.0			VADC analog input channel 0 of group 4
	SENT4A			SENT input channel 4, pin A
37	AN33	I	S / HighZ / VDDM	Analog input 33
	VADCG4.1			VADC analog input channel 1 of group 4 (MD)
	SENT5A			SENT input channel 5, pin A
36	AN35	I	D / HighZ / VDDM	Analog input 35
	VADCG4.3			VADC analog input channel 3 of group 4 (with pull down diagnostics)

**Package and Pinning Definitions TC275x Pin Definition and Functions:**
**Table 2-15 Analog Inputs (cont'd)**

Pin	Symbol	Ctrl	Type	Function
35	AN36	I	S / HighZ / VDDM	Analog input 34
	VADCG4.4			VADC analog input channel 4 of group 4
	DS3PA			DSADC: positive analog input of channel of DSADC 3, pin A
	SENT6A			SENT input channel 6, pin A
34	AN37	I	S / HighZ / VDDM	Analog input 37
	VADCG4.5			VADC analog input channel 5 of group 4
	DS3NA			DSADC: negative analog input of channel of DSADC 3, pin A
	SENT7A			SENT input channel 7, pin A
33	AN38	I	S / HighZ / VDDM	Analog input 38
	VADCG4.6			VADC analog input channel 6 of group 4
	DS3PB			DSADC: positive analog input of channel of DSADC 3, pin B
	SENT8A			SENT input channel 8, pin A
32	AN39	I	S / HighZ / VDDM	Analog input 39
	VADCG4.7			VADC analog input channel 7 of group 4
	DS3NB			DSADC: negative analog input of channel of DSADC 3, pin B
	SENT9A			SENT input channel 9, pin A
31	AN44	I	D / HighZ / VDDM	Analog input 44
	VADCG5.4			VADC analog input channel 4 of group 5
	DS3PC			DSADC: positive analog input of channel of DSADC 3, pin C
30	AN45	I	D / HighZ / VDDM	Analog input 45
	VADCG5.5			VADC analog input channel 5 of group 5
	DS3NC			DSADC: negative analog input of channel of DSADC 3, pin C
29	AN46	I	D / HighZ / VDDM	Analog input 46
	VADCG5.6			VADC analog input channel 6 of group 5
	DS3PD			DSADC: positive analog input of channel of DSADC 3, pin D
28	AN47	I	D / HighZ / VDDM	Analog input 47
	VADCG5.7			VADC analog input channel 7 of group 5
	DS3ND			DSADC: negative analog input of channel of DSADC 3, pin D

**Package and Pinning Definitions TC275x Pin Definition and Functions:**
**Table 2-16 System I/O**

Pin	Symbol	Ctrl	Type	Function
121	$\overline{\text{PORST}}$	I	I / PD / VEXT	Power On Reset Input Additional strong PD in case of power fail.
122	$\overline{\text{ESR0}}$	I/O	MP / OD / VEXT	External System Request Reset 0 Default configuration during and after reset is open-drain driver. The driver drives low during power-on reset. This is valid additionally after deactivation of $\overline{\text{PORST}}$ until the internal reset phase has finished. See also SCU chapter for details. Default after power-on can be different. See also SCU chapter 'Reset Control Unit' and SCU_IOCR register description.
	EVRWUP	I		EVR Wakeup Pin
120	$\overline{\text{ESR1}}$	I/O	MP / PU1 / VEXT	External System Request Reset 1 Default NMI function. See also SCU chapter 'Reset Control Unit' and SCU_IOCR register description.
	EVRWUP	I		EVR Wakeup Pin
85	VGATE1P	O	VGATE1P / - / VEXT	External Pass Device gate control for EVR13
112	TMS	I	A2 /	JTAG Module State Machine Control Input
	DAP1	I/O	PD / VDDP3	Device Access Port Line 1
114	$\overline{\text{TRST}}$	I	A2 / PD / VDDP3	JTAG Module Reset/Enable Input
115	TCK	I	A2 /	JTAG Module Clock Input
	DAP0	I	PD / VDDP3	Device Access Port Line 0
102	XTAL1	I	XTAL1 / - / VDDP3	Main Oscillator/PLL/Clock Generator Input
103	XTAL2	O	XTAL2 / - / VDDP3	Main Oscillator/PLL/Clock Generator Output

**Table 2-17 Supply**

Pin	Symbol	Ctrl	Type	Function
52	VAREF1	I	Vx	Positive Analog Reference Voltage 1
51	VAGND1	I	Vx	Negative Analog Reference Voltage 1

**Package and Pinning Definitions TC275x Pin Definition and Functions:**
**Table 2-17 Supply (cont'd)**

Pin	Symbol	Ctrl	Type	Function
26	VAREF2	I	Vx	Positive Analog Reference Voltage 2
27	VAGND2	I	Vx	Negative Analog Reference Voltage 2
54	VDDM	I	Vx	ADC Analog Power Supply (3.3V / 5V)
101	VSS	I	Vx	Digital Ground
10	VDD / VDDSB	I	Vx	Emulation Device: Emulation SRAM Standby Power Supply (1.3V) (Emulation Device only). Production Device: VDD (1.3V).
123, 68, 24	VDD	I	Vx	Digital Core Power Supply (1.3V)
100	VDD	I	Vx	Digital Core Power Supply (1.3V). The supply pin inturn supplies the main XTAL Oscillator/PLL (1.3V) . A higher decoupling capacitor is therefore recommended to the VSS pin for better noise immunity.
153, 99, 69, 25	VEXT	I	Vx	External Power Supply (5V / 3.3V)
154	VDDP3	I	Vx	Digital Power Supply for Flash (3.3V). Can be also used as external 3.3V Power Supply for VFLEX.
104	VDDP3	I	Vx	Digital Power Supply for Oscillator, LVDSH and A2 pads (3.3V). The supply pin inturn supplies the main XTAL Oscillator/PLL (3.3V) . A higher decoupling capacitor is therefore recommended to the VSS pin for better noise immunity.
155	VDDFL3	I	Vx	Flash Power Supply (3.3V)
164	VFLEX	I	Vx	Digital Power Supply for Flex Port Pads (5V / 3.3V)
53	VSSM	I	Vx	Analog Ground for VDDM

**Legend:**

Column "Ctrl.":

 I = Input (for GPIO port Lines with IOCR bit field Selection PCx = 0XXX<sub>B</sub>)

O = Output

 O0 = Output with IOCR bit field selection PCx = 1X000<sub>B</sub>

 O1 = Output with IOCR bit field selection PCx = 1X001<sub>B</sub> (ALT1)

 O2 = Output with IOCR bit field selection PCx = 1X010<sub>B</sub> (ALT2)

**Package and Pinning Definitions TC275x Pin Definition and Functions:**

O3 = Output with IOCR bit field selection PCx = 1X011<sub>B</sub> (ALT3)  
 O4 = Output with IOCR bit field selection PCx = 1X100<sub>B</sub> (ALT4)  
 O5 = Output with IOCR bit field selection PCx = 1X101<sub>B</sub> (ALT5)  
 O6 = Output with IOCR bit field selection PCx = 1X110<sub>B</sub> (ALT6)  
 O7 = Output with IOCR bit field selection PCx = 1X111<sub>B</sub> (ALT7)

Column "Type":

LP = Pad class LP (5V/3.3V, LVTTTL)

MP = Pad class MP (5V/3.3V, LVTTTL)

MP+ = Pad class MP+ (5V/3.3V, LVTTTL)

MPR = Pad class MPR (5V/3.3V, LVTTTL)

A2 = Pad class A2 (3.3V, LVTTTL)

LVDSM = Pad class LVDSM (LVDS/CMOS 5V/3.3V)

LVDSH = Pad class LVDSH (LVDS/CMOS 3.3V)

S = Pad class S (ADC overlaid with General Purpose Input)

D = Pad class D (ADC)

PU = with pull-up device connected during reset ( $\overline{\text{PORST}} = 0$ )

PU1 = with pull-up device connected during reset ( $\overline{\text{PORST}} = 0$ )<sup>1) 2) 3)</sup>

PD = with pull-down device connected during reset ( $\overline{\text{PORST}} = 0$ )

PD1 = with pull-down device connected during reset ( $\overline{\text{PORST}} = 0$ )<sup>1) 2) 3)</sup>

PX = Behavior depends on usage: PD in EVR13 SMPS Mode and PU1 in GPIO Mode

OD = open drain during reset ( $\overline{\text{PORST}} = 0$ )

HighZ = tri-state during reset ( $\overline{\text{PORST}} = 0$ )

$\overline{\text{PORST}}$  =  $\overline{\text{PORST}}$  input pad

XTAL1 = XTAL1 input pad

XTAL2 = XTAL2 input pad

VGATE1P = VGATE1P

VGATE3P = VGATE3P

Vx = Supply (the Exposed Pad is also considered as VSS and shall be connected to ground)

NC = These pins are reserved for future extensions and shall not be connected externally

NC1 = These pins are not connected on package level and will not be used for future extensions

NCVDDPSB = This pin has a different functionality in an Production Device and an Emulation Device. For details pls. see Pin/Ball description of this pin.

NCVDDSB = This pin has a different functionality in an Production Device and an Emulation Device. For details pls. see Pin/Ball description of this pin.

### 2.1.2 Emergency Stop Function

The Emergency Stop function can be used to force GPIOs (General Purpose Inputs/Outputs) via an external input signal (EMGSTOPA or EMGSTOPB) into a defined state:

- Input state and
- PU or High-Z depending on HWCFG[6] level latched during  $\overline{\text{PORST}}$  active

Control of the Emergency Stop function:

- 1) The default state of GPIOs (Px.y) during and after  $\overline{\text{PORST}}$  active is controlled via HWCFG[6] (P14.4). HWCFG[6] has a weak internal pull-up active at start-up if the pin is left unconnected. See also User's Manual, "Introduction Chapter", "General Purpose I/O Ports and Peripheral I/O Lines", Figure: "Default state of port pins during and after reset".
- 2) If HWCFG[6] is left unconnected or is externally pulled high, weak internal pull-ups (PU1) / pull-downs (PD1) are active during and after reset.
- 3) If HWCFG[6] is connected to ground, the PD1 / PU1 pins are predominantly in HighZ during and after reset.

**Package and Pinning Definitions TC275x Pin Definition and Functions:**

- The Emergency Stop function can be enabled/disabled in the SCU (see chapter “SCU”, “Emergency Stop Control”)
- The Emergency Stop input signal, EMGSTOPA (P33.8) / EMGSTOPB (P21.2) , can selected in the SCU (see chapter “SCU”, “Emergency Stop Control”)
- On port level, each GPIO can be enabled/disabled for the Emergency Stop function via the Px\_ESR (Port x Emergency Stop) registers in the port control logic (see chapter “General Purpose I/O Ports and Peripheral I/O Lines”, “Emergency Stop Register”).

The Emergency Stop function is available for all GPIO Ports with the following exceptions:

- Not available for P20.2 (General Purpose Input/GPI only, overlaid with Testmode)
- Not available for P40.x (analoge input ANx overlaid with GPI)
- Not available for P32.0 EVR13 SMPS mode.
- Not available for dedicated I/O without General Purpose Output function (e.g ESRx, TMS, TCK)

The Emergency Stop function can be overruled on the following GPIO Ports:

- P00.x: Emergency Stop can be overruled by the VADC. Overruling can be disabled via the control register P00\_SCR (see chapter “General Purpose I/O Ports and Peripheral I/O Lines”, P00)
- P14.0 and P14.1: Emergency Stop can be overruled in the DXCPL mode (DAP over can physical layer mode). No Overruling in the DXCM (Debug over can message) mode
- P21.6: Emergency Stop can be overruled in JTAG mode if this pin is used as TDI
- P21.7: Emergency Stop can be overruled in JTAG or Three Pin DAP mode
- P20.0: Emergency Stop can be overruled in JTAG mode if this GPIO is used as TDI

### 2.1.3 Pull-Up/Pull-Down Reset Behavior of the Pins

**Table 2-18 List of Pull-Up/Pull-Down Reset Behavior of the Pins**

<b>Pins</b>	<b>PORST = 0</b>	<b>PORST = 1</b>
all GPIOs	Pull-up if HWCFG[6] = 1 or High-Z if HWCFG[6] = 0	
TDI, TESTMODE	Pull-up	
PORST <sup>1)</sup>	Pull-down with $I_{PORST}$ relevant	Pull-down with $I_{PDLI}$ relevant
TRST, TCK, TMS	Pull-down	
ESR0	The open-drain driver is used to drive low. <sup>2)</sup>	Pull-up <sup>3)</sup>
ESR1	Pull-up <sup>3)</sup>	
TDO	Pull-up	High-Z/Pull-up <sup>4)</sup>

1) Pull-down with  $I_{PORST}$  relevant is always activated when a primary supply monitor detects a violation.

2) Valid additionally after deactivation of  $\overline{PORST}$  until the internal reset phase has finished. See the SCU chapter for details.

3) See the SCU\_IOCRR register description.

4) Depends on JTAG/DAP selection with  $\overline{TRST}$ .

In case of leakage test ( $\overline{PORST} = 0$  and  $\overline{TESTMODE} = 0$ ), the pull-down of the  $\overline{TRST}$  pin is switched off. In case of an user application ( $\overline{TESTMODE} = 1$ ), the pull-down of the  $\overline{TRST}$  is always switched on.

Package and Pinning Definitions TC277x Pin Definition and Functions:

2.2 TC277x Pin Definition and Functions: BGA292

Figure 2-2 is showing the TC277x Logic Symbol for the package variant: BGA292.

	20	19	18	17	16	15	14	13	12	11	10	9	8	7	6	5	4	3	2	1			
Y	VSS	P32.3	P32.2	P32.0	P33.13	P33.11	P33.9	P33.7	P33.5	P33.3	P33.1	AN5	AN10	VAGND1	VAREF1	VDDM	VSSM	AN20	AN21	NC	Y		
W	VEXT	VSS	P32.4	VGATE1P	P33.12	P33.10	P33.8	P33.6	P33.4	P33.2	P33.0	AN2	AN8	AN11	AN13	AN16	AN18	AN19	AN24	AN25	W		
V	P23.0	VEXT																		AN26	AN27	V	
U	P23.2	P23.1	U	VSS	P32.7	P32.6	P33.15	P34.5	P34.3	P34.1	AN1	AN3	AN7	AN9	AN14	AN17	NC	U		AN28	AN29	U	
T	P23.4	P23.3	T	P23.5	VSS	P32.5	P33.14	P34.4	P34.2	VEVRSB	AND	AN4	AN6	AN12	AN15	AN22	AN30	T	VAGND2	VAREF2	T		
R	P22.2	P22.3	R	P23.6	P23.7	Top-View												AN23	AN31	R	AN35	AN33	R
P	P22.0	P22.1	P	P22.5	P22.4			VDD	VSS	VSS (AGBT TXDP)	VSS (AGBT TXDN)	VSS	VDD				AN34	AN32	P		AN37	AN39	P
N	VDDP3	VDD	N	P22.7	P22.6		VDD		VSS	VSS	VSS	VSS		VDD			AN38	AN36	N		AN45	AN44	N
M	XTAL1	XTAL2	M	P22.9	P22.8		VSS	VSS		VSS	VSS		VSS	VSS			AN40	AN41	M		AN47	AN46	M
L	VSS	TRST	L	P22.11	P22.10		VSS (AGBT ERR)	VSS	VSS	VSS	VSS	VSS	VSS	VSS			AN42	AN43	L	P00.12	P00.11	L	
K	P21.4	P21.2	K	P21.0	TMS		NC (VDDP3B)	VSS	VSS	VSS	VSS	VSS	VSS	VSS			P00.10	P00.8	K	P00.10	P00.8	K	
J	P21.5	P21.3	J	P21.1	TCK		VSS	VSS		VSS	VSS		VSS	VSS			P01.7	P00.6	J	P00.5	P00.4	J	
H	P20.0	P20.2	H	P21.6	P21.7		VDD		VSS	VSS	VSS	VSS		VDD (VDDSB)			P01.5	P01.6	H	P00.3	P00.2	H	
G	P20.3	P20.1	G	PORST	ESR1			VDD	VSS	VSS	VSS	VSS	VDD (VDDSB)				P01.3	P01.4	G	P00.1	P00.0	G	
F	P20.8	P20.7	F	P20.6	ESR0												P02.10	P02.11	F	P02.7	P02.8	F	
E	P20.11	P20.10	E	P20.9	VSS	VDDFL3	P15.5	P14.2	P12.0	P12.1	P11.0	P11.1	P11.7	P11.8	P11.13	VSS	P02.9	E	P02.5	P02.6	E		
D	P20.13	P20.12	D	VSS	VDDFL3	P15.7	P15.8	P14.7	P14.9	P14.10	P11.4	P11.6	P11.5	P11.14	P11.15	VFLEX	VSS	D	P02.3	P02.4	D		
C	P20.14	P15.2				17	16	15	14	13	12	11	10	9	8	7	6	5	4		P02.1	P02.2	C
B	P15.0	VSS	VDDP3	P15.3	P14.0	P14.4	P14.3	P14.6	P13.0	P13.2	P11.3	P11.10	P11.12	P10.1	P10.4	P10.5	P10.8	VEXT	VSS	P02.0	B		
A	VSS	VDDP3	P15.1	P15.4	P15.6	P14.1	P14.5	P14.8	P13.1	P13.3	P11.2	P11.9	P11.11	P10.0	P10.3	P10.2	P10.6	P10.7	VEXT	NC	A		
	20	19	18	17	16	15	14	13	12	11	10	9	8	7	6	5	4	3	2	1			

Figure 2-2 TC277x Logic Symbol for the package variant BGA292.

## 2.2.1 TC277xBGA292 Package Variant Pin Configuration

Table 2-19 Port 00 Functions

Pin	Symbol	Ctrl	Type	Function	
G1	P00.0	I	MP / PU1 / VEXT	General-purpose input	
	TIN9			GTM input	
	CTRAPA			CCU61 input	
	T12HRE			CCU60 input	
	INJ00			MSC0 input	
	CIFD9			CIF input	
	P00.0	O0		General-purpose output	
	TOUT9	O1		GTM output	
	ASCLK3	O2		ASCLIN3 output	
	ATX3	O3		ASCLIN3 output	
	–	O4		Reserved	
	TXDCAN1	O5		CAN node 1 output	
	–	O6		Reserved	
	COUT63	O7		CCU60 output	
	ETHMDIOA	HWOUT		ETH input/output	
	G2	P00.1		I	LP / PU1 / VEXT
TIN10		GTM input			
ARX3E		ASCLIN3 input			
RXDCAN1D		CAN node 1 input			
PSIRX0A		PSI5 input			
SENT0B		SENT input			
CC60INB		CCU60 input			
CC60INA		CCU61 input			
DSCIN5A		DSADC channel 5 input A			
DS5NA		DSADC negative analog input of channel 5, pin A			
VADCG7.5		VADC analog input channel 5 of group 7			
CIFD10		CIF input			
P00.1		O0	General-purpose output		
TOUT10		O1	GTM output		
ATX3		O2	ASCLIN3 output		
–		O3	Reserved		
DSCOUT5	O4	DSADC channel 5 output			
–	O5	Reserved			
SPC0	O6	SENT output			
CC60	O7	CCU61 output			

## Package and Pinning Definitions TC277x Pin Definition and Functions:

Table 2-19 Port 00 Functions (cont'd)

Pin	Symbol	Ctrl	Type	Function	
H1	P00.2	I	LP / PU1 / VEXT	General-purpose input	
	TIN11			GTM input	
	SENT1B			SENT input	
	DSDIN5A			DSADC channel 5 input A	
	DS5PA			DSADC positive analog input of channel 5, pin A	
	VADCG7.4			VADC analog input channel 4 of group 7	
	CIFD11			CIF input	
	P00.2			O0	General-purpose output
	TOUT11	O1		GTM output	
	ASCLK3	O2		ASCLIN3 output	
	–	O3		Reserved	
	PSITX0	O4		PSI5 output	
	TXDCAN3	O5		CAN node 3 output	
	–	O6		Reserved	
	COOUT60	O7		CCU61 output	
	H2	P00.3		I	LP / PU1 / VEXT
TIN12		GTM input			
RXDCAN3A		CAN node 3 input			
PSIRX1A		PSI5 input			
PSISRXA		PSI5-S input			
SENT2B		SENT input			
CC61INB		CCU60 input			
CC61INA		CCU61 input			
DSCIN3A		DSADC channel 3 input A			
VADCG7.3		VADC analog input channel 3 of group 7			
DSITR5F		DSADC channel 5 input F			
CIFD12		CIF input			
P00.3		O0	General-purpose output		
TOUT12		O1	GTM output		
ASLSO3		O2	ASCLIN3 output		
–		O3	Reserved		
DSCOUT3		O4	DSADC channel 3 output		
–		O5	Reserved		
SPC2		O6	SENT output		
CC61		O7	CCU61 output		

## Package and Pinning Definitions TC277x Pin Definition and Functions:

Table 2-19 Port 00 Functions (cont'd)

Pin	Symbol	Ctrl	Type	Function
J1	P00.4	I	LP / PU1 / VEXT	General-purpose input
	TIN13			GTM input
	REQ7			SCU input
	SENT3B			SENT input
	DSDIN3A			DSADC channel 3 input A
	DSSGNA			DSADC input
	VADCG7.2			VADC analog input channel 2 of group 7 (MD)
	CIFD13			CIF input
	P00.4	O0		General-purpose output
	TOUT13	O1		GTM output
	PSISTX	O2		PSI5-S output
	–	O3		Reserved
	PSITX1	O4		PSI5 output
	VADCG4BFL0	O5		VADC output
	SPC3	O6		SENT output
	COU61	O7		CCU61 output
J2	P00.5	I	LP / PU1 / VEXT	General-purpose input
	TIN14			GTM input
	PSIRX2A			PSI5 input
	SENT4B			SENT input
	CC62INB			CCU60 input
	CC62INA			CCU61 input
	DSCIN2A			DSADC channel 2 input A
	VADCG7.1			VADC analog input channel 1 of group 7 (MD)
	CIFD14	CIF input		
	P00.5	O0		General-purpose output
	TOUT14	O1		GTM output
	DSCGPWMN	O2		DSADC output
	–	O3		Reserved
	DSCOUT2	O4		DSADC channel 2 output
	VADCG4BFL1	O5		VADC output
	SPC4	O6		SENT output
CC62	O7	CCU61 output		

## Package and Pinning Definitions TC277x Pin Definition and Functions:

Table 2-19 Port 00 Functions (cont'd)

Pin	Symbol	Ctrl	Type	Function	
J4	P00.6	I	LP / PU1 / VEXT	General-purpose input	
	TIN15			GTM input	
	SENT5B			SENT input	
	DSDIN2A			DSADC channel 2 input A	
	VADCG7.0			VADC analog input channel 0 of group 7	
	DSITR4F			DSADC channel 4 input F	
	CIFD15			CIF input	
	P00.6	O0		General-purpose output	
	TOUT15	O1		GTM output	
	DSCGPWMP	O2		DSADC output	
	VADCG4BFL2	O3		VADC output	
	PSITX2	O4		PSI5 output	
	VADCEMUX10	O5		VADC output	
	SPC5	O6		SENT output	
	COUT62	O7		CCU61 output	
K1	P00.7	I	LP / PU1 / VEXT	General-purpose input	
	TIN16			GTM input	
	SENT6B			SENT input	
	CC60INC			CCU61 input	
	CCPOS0A			CCU61 input	
	T12HRB			CCU60 input	
	T2INA			GPT120 input	
	DSCIN4A			DSADC channel 4 input A	
	DS4NA			DSADC negative analog input of channel 4, pin A	
	VADCG6.5			VADC analog input channel 5 of group 6	
	CIFCLK			CIF input	
	P00.7			O0	General-purpose output
	TOUT16			O1	GTM output
	–	O2		Reserved	
	VADCG4BFL3	O3		VADC output	
	DSCOUT4	O4		DSADC channel 4 output	
	VADCEMUX11	O5		VADC output	
	SPC6	O6		SENT output	
	CC60	O7		CCU61 output	

## Package and Pinning Definitions TC277x Pin Definition and Functions:

Table 2-19 Port 00 Functions (cont'd)

Pin	Symbol	Ctrl	Type	Function
K4	P00.8	I	LP / PU1 / VEXT	General-purpose input
	TIN17			GTM input
	SENT7B			SENT input
	CC61INC			CCU61 input
	CCPOS1A			CCU61 input
	T13HRB			CCU60 input
	T2EUDA			GPT120 input
	DSDIN4A			DSADC channel 4 input A
	DS4PA			DSADC channel 4 input A
	VADCG6.4			VADC analog input channel 4 of group 6
	CIFVSNC			CIF input
	P00.8			O0
	TOUT17	O1	GTM output	
	SLSO36	O2	QSPI3 output	
	–	O3	Reserved	
	–	O4	Reserved	
	VADCEMUX12	O5	VADC output	
	SPC7	O6	SENT output	
	CC61	O7	CCU61 output	

## Package and Pinning Definitions TC277x Pin Definition and Functions:

Table 2-19 Port 00 Functions (cont'd)

Pin	Symbol	Ctrl	Type	Function
K2	P00.9	I	LP / PU1 / VEXT	General-purpose input
	TIN18			GTM input
	SENT8B			SENT input
	CC62INC			CCU61 input
	CCPOS2A			CCU61 input
	T13HRC			CCU60 input
	T12HRC			CCU60 input
	T4EUDA			GPT120 input
	DSCIN1A			DSADC channel 1 input A
	VADCG6.3			VADC analog input channel 3 of group 6
	DSITR3F			DSADC channel 3 input F
	CIFHSNC			CIF input
	P00.9	O0		General-purpose output
	TOUT18	O1		GTM output
	SLSO37	O2		QSPI3 output
	ARTS3	O3		ASCLIN3 output
	DSCOUT1	O4		DSADC channel 1 output
	–	O5		Reserved
SPC8	O6	SENT output		
CC62	O7	CCU61 output		
K5	P00.10	I	LP / PU1 / VEXT	General-purpose input
	TIN19			GTM input
	SENT9B			SENT input
	DSDIN1A			DSADC channel 1 input A
	VADCG6.2			VADC analog input channel 2 of group 6 (MD)
	P00.10	O0		General-purpose output
	TOUT19	O1		GTM output
	–	O2		Reserved
	–	O3		Reserved
	–	O4		Reserved
	–	O5		Reserved
	SPC9	O6		SENT output
	COUT63	O7		CCU61 output

## Package and Pinning Definitions TC277x Pin Definition and Functions:

Table 2-19 Port 00 Functions (cont'd)

Pin	Symbol	Ctrl	Type	Function
L1	P00.11	I	LP / PU1 / VEXT	General-purpose input
	TIN20			GTM input
	CTRAPA			CCU60 input
	T12HRE			CCU61 input
	DSCIN0A			DSADC channel 0 input A
	VADCG6.1			VADC analog input channel 1 of group 6 (MD)
	P00.11			O0
	TOUT20	O1		GTM output
	—	O2		Reserved
	—	O3		Reserved
	DSCOUT0	O4		DSADC channel 0 output
	—	O5		Reserved
	—	O6		Reserved
	—	O7		Reserved
L2	P00.12	I	LP / PU1 / VEXT	General-purpose input
	TIN21			GTM input
	ACTS3A			ASCLIN3 input
	DSDIN0A			DSADC channel 0 input A
	VADCG6.0			VADC analog input channel 0 of group 6
	P00.12	O0		General-purpose output
	TOUT21	O1		GTM output
	—	O2		Reserved
	—	O3		Reserved
	—	O4		Reserved
	—	O5		Reserved
	—	O6		Reserved
	COUT63	O7		CCU61 output

## Package and Pinning Definitions TC277x Pin Definition and Functions:

Table 2-20 Port 01 Functions

Pin	Symbol	Ctrl	Type	Function
<b>G5</b>	P01.3	I	<b>LP / PU1 / VEXT</b>	General-purpose input
	TIN111			GTM input
	SLSI3B			QSPI3 input
	P01.3	O0		General-purpose output
	TOUT111	O1		GTM output
	—	O2		Reserved
	—	O3		Reserved
	SLSO39	O4		QSPI3 output
	TXDCAN1	O5		CAN node 1 output
	—	O6		Reserved
	—	O7		Reserved
	<b>G4</b>	P01.4		I
TIN112		GTM input		
RXDCAN1C		CAN node 1 input		
P01.4		O0	General-purpose output	
TOUT112		O1	GTM output	
—		O2	Reserved	
—		O3	Reserved	
SLSO310		O4	QSPI3 output	
—		O5	Reserved	
—		O6	Reserved	
—		O7	Reserved	
<b>H5</b>		P01.5	I	<b>LP / PU1 / VEXT</b>
	TIN113	GTM input		
	MRST3C	QSPI3 input		
	P01.5	O0	General-purpose output	
	TOUT113	O1	GTM output	
	—	O2	Reserved	
	—	O3	Reserved	
	MRST3	O4	QSPI3 output	
	—	O5	Reserved	
	—	O6	Reserved	
	—	O7	Reserved	

## Package and Pinning Definitions TC277x Pin Definition and Functions:

Table 2-20 Port 01 Functions (cont'd)

Pin	Symbol	Ctrl	Type	Function
H4	P01.6	I	LP / PU1 / VEXT	General-purpose input
	TIN114			GTM input
	MTSR3C			QSPI3 input
	P01.6	O0		General-purpose output
	TOUT114	O1		GTM output
	—	O2		Reserved
	—	O3		Reserved
	MTSR3	O4		QSPI3 output
	—	O5		Reserved
	—	O6		Reserved
	—	O7		Reserved
J5	P01.7	I	LP / PU1 / VEXT	General-purpose input
	TIN115			GTM input
	SCLK3C			QSPI3 input
	P01.7	O0		General-purpose output
	TOUT115	O1		GTM output
	—	O2		Reserved
	—	O3		Reserved
	SCLK3	O4		QSPI3 output
	—	O5		Reserved
	—	O6		Reserved
	—	O7		Reserved

## Package and Pinning Definitions TC277x Pin Definition and Functions:

Table 2-21 Port 02 Functions

Pin	Symbol	Ctrl	Type	Function
B1	P02.0	I	MP+ / PU1 / VEXT	General-purpose input
	TIN0			GTM input
	ARX2G			ASCLIN2 input
	REQ6			SCU input
	CC60INA			CCU60 input
	CC60INB			CCU61 input
	CIFD0			CIF input
	P02.0			O0
	TOUT0	O1		GTM output
	ATX2	O2		ASCLIN2 output
	SLSO31	O3		QSPI3 output
	DSCGPWMN	O4		DSADC output
	TXDCAN0	O5		CAN node 0 output
	TXDA	O6		ERAY output
	CC60	O7		CCU60 output
	C2	P02.1		I
TIN1		GTM input		
REQ14		SCU input		
ARX2B		ASCLIN2 input		
RXDCAN0A		CAN node 0 input		
RXDA2		ERAY input		
CIFD1		CIF input		
P02.1		O0	General-purpose output	
TOUT1		O1	GTM output	
–		O2	Reserved	
SLSO32		O3	QSPI3 output	
DSCGPWMP		O4	DSADC output	
–		O5	Reserved	
–		O6	Reserved	
COUT60		O7	CCU60 output	

## Package and Pinning Definitions TC277x Pin Definition and Functions:

Table 2-21 Port 02 Functions (cont'd)

Pin	Symbol	Ctrl	Type	Function
<b>C1</b>	P02.2	I	<b>MP+ / PU1 / VEXT</b>	General-purpose input
	TIN2			GTM input
	CC61INA			CCU60 input
	CC61INB			CCU61 input
	CIFD2			CIF input
	P02.2	O0		General-purpose output
	TOUT2	O1		GTM output
	ATX1	O2		ASCLIN1 output
	SLSO33	O3		QSPI3 output
	PSITX0	O4		PSI5 output
	TXDCAN2	O5		CAN node 2 output
	TXDB	O6		ERAY output
	CC61	O7		CCU60 output
	<b>D2</b>	P02.3		I
TIN3		GTM input		
ARX1G		ASCLIN1 input		
RXDCAN2B		CAN node 2 input		
RXDB2		ERAY input		
PSIRX0B		PSI5 input		
DSCIN5B		DSADC channel 5 input B		
SDI11		MSC1 input		
CIFD3		CIF input		
P02.3		O0	General-purpose output	
TOUT3		O1	GTM output	
ASLSO2		O2	ASCLIN2 output	
SLSO34		O3	QSPI3 output	
DSCOUT5		O4	DSADC channel 5 output	
–		O5	Reserved	
–		O6	Reserved	
COUT61		O7	CCU60 output	

## Package and Pinning Definitions TC277x Pin Definition and Functions:

Table 2-21 Port 02 Functions (cont'd)

Pin	Symbol	Ctrl	Type	Function	
<b>D1</b>	P02.4	I	<b>MP+ / PU1 / VEXT</b>	General-purpose input	
	TIN4			GTM input	
	SLSI3A			QSPI3 input	
	ECTT1			TTCAN input	
	RXDCAN0D			CAN node 0 input	
	CC62INA			CCU60 input	
	CC62INB			CCU61 input	
	DSDIN5B			DSADC channel 5 input B	
	SDA0A			I2C0 input	
	CIFD4			CIF input	
	P02.4			O0	General-purpose output
	TOUT4			O1	GTM output
	ASCLK2			O2	ASCLIN2 output
	SLSO30			O3	QSPI3 output
	PSISCLK			O4	PSI5-S output
	SDA0			O5	I2C0 output
	TXENA			O6	ERAY output
	CC62	O7	CCU60 output		
<b>E2</b>	P02.5	I	<b>MP+ / PU1 / VEXT</b>	General-purpose input	
	TIN5			GTM input	
	MRST3A			QSPI3 input	
	ECTT2			TTCAN input	
	PSIRX1B			PSI5 input	
	PSISRXB			PSI5-S input	
	SENT3C			SENT input	
	DSCIN4B			DSADC channel 4 input B	
	SCL0A			I2C0 input	
	CIFD5			CIF input	
	P02.5			O0	General-purpose output
	TOUT5			O1	GTM output
	TXDCAN0			O2	CAN node 0 output
	MRST3			O3	QSPI3 output
	DSCOUT4			O4	DSADC channel 4 output
	SCL0			O5	I2C0 output
	TXENB			O6	ERAY output
	COU62	O7	CCU60 output		

## Package and Pinning Definitions TC277x Pin Definition and Functions:

Table 2-21 Port 02 Functions (cont'd)

Pin	Symbol	Ctrl	Type	Function	
E1	P02.6	I	MP / PU1 / VEXT	General-purpose input	
	TIN6			GTM input	
	MISR3A			QSPI3 input	
	SENT2C			SENT input	
	CC60INC			CCU60 input	
	CCPOS0A			CCU60 input	
	T12HRB			CCU61 input	
	T3INA			GPT120 input	
	CIFD6			CIF input	
	DSDIN4B			DSADC channel 4 input B	
	DSITR5E			DSADC channel 5 input E	
	P02.6			O0	General-purpose output
	TOUT6			O1	GTM output
	PSISTX	O2	PSI5-S output		
	MISR3	O3	QSPI3 output		
	PSITX1	O4	PSI5 output		
	VADCEMUX00	O5	VADC output		
	-	O6	Reserved		
	CC60	O7	CCU60 output		

## Package and Pinning Definitions TC277x Pin Definition and Functions:

Table 2-21 Port 02 Functions (cont'd)

Pin	Symbol	Ctrl	Type	Function		
F2	P02.7	I	<b>MP / PU1 / VEXT</b>	General-purpose input		
	TIN7			GTM input		
	SCLK3A			QSPI3 input		
	PSIRX2B			PSI5 input		
	SENT1C			SENT input		
	CC61INC			CCU60 input		
	CCPOS1A			CCU60 input		
	T13HRB			CCU61 input		
	T3EUDA			GPT120 input		
	CIFD7			CIF input		
	DSCIN3B			DSADC channel 3 input B		
	DSITR4E			DSADC channel 4 input E		
	P02.7			O0		General-purpose output
	TOUT7			O1		GTM output
	–	O2		Reserved		
	SCLK3	O3		QSPI3 output		
	DSCOUT3	O4		DSADC channel 3 output		
	VADCEMUX01	O5		VADC output		
	SPC1	O6		SENT output		
	CC61	O7		CCU60 output		

## Package and Pinning Definitions TC277x Pin Definition and Functions:

Table 2-21 Port 02 Functions (cont'd)

Pin	Symbol	Ctrl	Type	Function
F1	P02.8	I	LP / PU1 / VEXT	General-purpose input
	TIN8			GTM input
	SENT0C			SENT input
	CC62INC			CCU60 input
	CCPOS2A			CCU60 input
	T12HRC			CCU61 input
	T13HRC			CCU61 input
	T4INA			GPT120 input
	CIFD8			CIF input
	DSDIN3B			DSADC channel 3 input B
	DSITR3E			DSADC channel 3 input E
	P02.8	O0	General-purpose output	
	TOUT8	O1	GTM output	
	SLSO35	O2	QSPI3 output	
	–	O3	Reserved	
	PSITX2	O4	PSI5 output	
	VADCEMUX02	O5	VADC output	
ETHMDC	O6	ETH output		
CC62	O7	CCU60 output		
E4	P02.9	I	LP / PU1 / VEXT	General-purpose input
	TIN116			GTM input
	P02.9	O0		General-purpose output
	TOUT116	O1		GTM output
	ATX2	O2		ASCLIN2 output
	–	O3		Reserved
	–	O4		Reserved
	TXDCAN1	O5		CAN node 1 output
	–	O6		Reserved
	–	O7		Reserved

## Package and Pinning Definitions TC277x Pin Definition and Functions:

Table 2-21 Port 02 Functions (cont'd)

Pin	Symbol	Ctrl	Type	Function
F5	P02.10	I	LP / PU1 / VEXT	General-purpose input
	TIN117			GTM input
	ARX2C			ASCLIN2 input
	RXDCAN1E			CAN node 1 input
	P02.10	O0		General-purpose output
	TOUT117	O1		GTM output
	—	O2		Reserved
	—	O3		Reserved
	—	O4		Reserved
	—	O5		Reserved
	—	O6		Reserved
	—	O7		Reserved
F4	P02.11	I	LP / PU1 / VEXT	General-purpose input
	TIN118			GTM input
	P02.11	O0		General-purpose output
	TOUT118	O1		GTM output
	—	O2		Reserved
	—	O3		Reserved
	—	O4		Reserved
	—	O5		Reserved
	—	O6		Reserved
	—	O7		Reserved

Table 2-22 Port 10 Functions

Pin	Symbol	Ctrl	Type	Function
A7	P10.0	I	LP / PU1 / VEXT	General-purpose input
	TIN102			GTM input
	T6EUDB			GPT120 input
	P10.0	O0		General-purpose output
	TOUT102	O1		GTM output
	—	O2		Reserved
	SLSO110	O3		QSPI1 output
	—	O4		Reserved
	VADCG6BFL0	O5		VADC output
	—	O6		Reserved
	—	O7		Reserved

## Package and Pinning Definitions TC277x Pin Definition and Functions:

Table 2-22 Port 10 Functions (cont'd)

Pin	Symbol	Ctrl	Type	Function
B7	P10.1	I	MP+ / PU1 / VEXT	General-purpose input
	TIN103			GTM input
	MRST1A			QSPI1 input
	T5EUDB			GPT120 input
	P10.1	O0		General-purpose output
	TOUT103	O1		GTM output
	MTRSR1	O2		QSPI1 output
	MRST1	O3		QSPI1 output
	EN01	O4		MSC0 output
	VADCG6BFL1	O5		VADC output
	END03	O6		MSC0 output
	-	O7		Reserved
	A5	P10.2		I
TIN104		GTM input		
SCLK1A		QSPI1 input		
T6INB		GPT120 input		
REQ2		SCU input		
RXDCAN2E		CAN node 2 input		
SDI01		MSC0 input		
P10.2		O0	General-purpose output	
TOUT104		O1	GTM output	
-		O2	Reserved	
SCLK1		O3	QSPI1 output	
EN00		O4	MSC0 output	
VADCG6BFL2		O5	VADC output	
END02		O6	MSC0 output	
-		O7	Reserved	

## Package and Pinning Definitions TC277x Pin Definition and Functions:

Table 2-22 Port 10 Functions (cont'd)

Pin	Symbol	Ctrl	Type	Function
<b>A6</b>	P10.3	I	<b>MP / PU1 / VEXT</b>	General-purpose input
	TIN105			GTM input
	M TSR1A			QSPI1 input
	REQ3			SCU input
	T5INB			GPT120 input
	P10.3	O0		General-purpose output
	TOUT105	O1		GTM output
	VADCG6BFL3	O2		VADC output
	M TSR1	O3		QSPI1 output
	EN00	O4		MSC0 output
	END02	O5		MSC0 output
	TXDCAN2	O6		CAN node 2 output
	-	O7		Reserved
	<b>B6</b>	P10.4		I
TIN106		GTM input		
M TSR1C		QSPI1 input		
CCPOS0C		CCU60 input		
T3INB		GPT120 input		
P10.4		O0	General-purpose output	
TOUT106		O1	GTM output	
-		O2	Reserved	
SLSO18		O3	QSPI1 output	
M TSR1		O4	QSPI1 output	
EN00		O5	MSC0 output	
END02		O6	MSC0 output	
-		O7	Reserved	
<b>B5</b>		P10.5	I	<b>LP / PU1 / VEXT</b>
	TIN107	GTM input		
	HWCFG4	SCU input		
	INJ01	MSC0 input		
	P10.5	O0		
	TOUT107	O1	GTM output	
	ATX2	O2	ASCLIN2 output	
	SLSO38	O3	QSPI3 output	
	SLSO19	O4	QSPI1 output	
	T6OUT	O5	GPT120 output	
	ASLSO2	O6	ASCLIN2 output	
	-	O7	Reserved	

## Package and Pinning Definitions TC277x Pin Definition and Functions:

Table 2-22 Port 10 Functions (cont'd)

Pin	Symbol	Ctrl	Type	Function
A4	P10.6	I	LP / PU1 / VEXT	General-purpose input
	TIN108			GTM input
	ARX2D			ASCLIN2 input
	MTR3B			QSPI3 input
	HWCFG5			SCU input
	P10.6	O0		General-purpose output
	TOUT108	O1		GTM output
	ASCLK2	O2		ASCLIN2 output
	MTR3	O3		QSPI3 output
	T3OUT	O4		GPT120 output
	-	O5		Reserved
	MRST1	O6		QSPI1 output
	VADCG7BFL0	O7		VADC output
	A3	P10.7		I
TIN109		GTM input		
ACTS2A		ASCLIN2 input		
MRST3B		QSPI3 input		
REQ4		SCU input		
CCPOS1C		CCU60 input		
T3EUDB		GPT120 input		
P10.7		O0	General-purpose output	
TOUT109		O1	GTM output	
-		O2	Reserved	
MRST3		O3	QSPI3 output	
VADCG7BFL1		O4	VADC output	
-		O5	Reserved	
-		O6	Reserved	
-	O7	Reserved		

**Package and Pinning Definitions TC277x Pin Definition and Functions:**
**Table 2-22 Port 10 Functions (cont'd)**

Pin	Symbol	Ctrl	Type	Function
<b>B4</b>	P10.8	I	<b>LP / PU1 / VEXT</b>	General-purpose input
	TIN110			GTM input
	SCLK3B			QSPI3 input
	REQ5			SCU input
	CCPOS2C			CCU60 input
	T4INB			GPT120 input
	P10.8			O0
	TOUT110	O1		GTM output
	ARTS2	O2		ASCLIN2 output
	SCLK3	O3		QSPI3 output
	–	O4		Reserved
	–	O5		Reserved
	–	O6		Reserved
	–	O7		Reserved

**Table 2-23 Port 11 Functions**

Pin	Symbol	Ctrl	Type	Function
<b>E10</b>	P11.0	I	<b>MP+ / PU1 / VFLEX</b>	General-purpose input
	TIN119			GTM input
	ARX3B			ASCLIN3 input
	P11.0	O0		General-purpose output
	TOUT119	O1		GTM output
	ATX3	O2		ASCLIN3 output
	–	O3		Reserved
	–	O4		Reserved
	–	O5		Reserved
	ETHTXD3	O6		ETH output
–	O7	Reserved		
<b>E9</b>	P11.1	I	<b>MP+ / PU1 / VFLEX</b>	General-purpose input
	TIN120			GTM input
	P11.1			General-purpose output
	TOUT120	O1		GTM output
	ASCLK3	O2		ASCLIN3 output
	ATX3	O3		ASCLIN3 output
	–	O4		Reserved
	–	O5		Reserved
	ETHTXD2	O6		ETH output
	–	O7		Reserved

## Package and Pinning Definitions TC277x Pin Definition and Functions:

Table 2-23 Port 11 Functions (cont'd)

Pin	Symbol	Ctrl	Type	Function
<b>A10</b>	P11.2	I	<b>MPR / PU1 / VFLEX</b>	General-purpose input
	TIN95			GTM input
	P11.2	O0		General-purpose output
	TOUT95	O1		GTM output
	END03	O2		MSC0 output
	SLSO05	O3		QSPI0 output
	SLSO15	O4		QSPI1 output
	EN01	O5		MSC0 output
	ETHTXD1	O6		ETH output
	COUT63	O7		CCU60 output
<b>B10</b>	P11.3	I	<b>MPR / PU1 / VFLEX</b>	General-purpose input
	TIN96			GTM input
	MRST1B			QSPI1 input
	SDI03			MSC0 input
	P11.3	O0		General-purpose output
	TOUT96	O1		GTM output
	–	O2		Reserved
	MRST1	O3		QSPI1 output
	TXDA	O4		ERAY output
	–	O5		Reserved
	ETHTXD0	O6		ETH output
	COUT62	O7		CCU60 output
<b>D10</b>	P11.4	I	<b>MP+ / PU1 / VFLEX</b>	General-purpose input
	TIN121			GTM input
	ETHRXCLKB			ETH input
	P11.4	O0		General-purpose output
	TOUT121	O1		GTM output
	ASCLK3	O2		ASCLIN3 output
	–	O3		Reserved
	–	O4		Reserved
	–	O5		Reserved
	ETHTXER	O6		ETH output
	–	O7		Reserved

## Package and Pinning Definitions TC277x Pin Definition and Functions:

Table 2-23 Port 11 Functions (cont'd)

Pin	Symbol	Ctrl	Type	Function
D8	P11.5	I	LP / PU1 / VFLEX	General-purpose input
	TIN122			GTM input
	ETHTXCLKA			ETH input
	P11.5	O0		General-purpose output
	TOUT122	O1		GTM output
	—	O2		Reserved
	—	O3		Reserved
	—	O4		Reserved
	—	O5		Reserved
	—	O6		Reserved
—	O7	Reserved		
D9	P11.6	I	MPR / PU1 / VFLEX	General-purpose input
	TIN97			GTM input
	SCLK1B			QSPI1 input
	P11.6	O0		General-purpose output
	TOUT97	O1		GTM output
	$\overline{\text{TXENB}}$	O2		ERAY output
	SCLK1	O3		QSPI1 output
	$\overline{\text{TXENA}}$	O4		ERAY output
	FCLP0	O5		MSC0 output
	ETHTXEN	O6		ETH output
	COUT61	O7		CCU60 output
E8	P11.7	I	LP / PU1 / VFLEX	General-purpose input
	TIN123			GTM input
	ETHRXD3			ETH input
	P11.7	O0		General-purpose output
	TOUT123	O1		GTM output
	—	O2		Reserved
	—	O3		Reserved
	—	O4		Reserved
	—	O5		Reserved
	—	O6		Reserved
—	O7	Reserved		

## Package and Pinning Definitions TC277x Pin Definition and Functions:

Table 2-23 Port 11 Functions (cont'd)

Pin	Symbol	Ctrl	Type	Function
E7	P11.8	I	LP / PU1 / VFLEX	General-purpose input
	TIN124			GTM input
	ETHRXD2			ETH input
	P11.8	O0		General-purpose output
	TOUT124	O1		GTM output
	–	O2		Reserved
	–	O3		Reserved
	–	O4		Reserved
	–	O5		Reserved
	–	O6		Reserved
–	O7	Reserved		
A9	P11.9	I	MP+ / PU1 / VFLEX	General-purpose input
	TIN98			GTM input
	MTSR1B			QSPI1 input
	RXDA1			ERAY input
	ETHRXD1			ETH input
	P11.9	O0		General-purpose output
	TOUT98	O1		GTM output
	–	O2		Reserved
	MTSR1	O3		QSPI1 output
	–	O4		Reserved
	SOP0	O5		MSC0 output
	–	O6		Reserved
	COU60	O7		CCU60 output

## Package and Pinning Definitions TC277x Pin Definition and Functions:

Table 2-23 Port 11 Functions (cont'd)

Pin	Symbol	Ctrl	Type	Function
B9	P11.10	I	LP / PU1 / VFLEX	General-purpose input
	TIN99			GTM input
	REQ12			SCU input
	ARX1E			ASCLIN1 input
	SLSI1A			QSPI1 input
	RXDCAN3D			CAN node 3 input
	RXDB1			ERAY input
	ETHRXD0			ETH input
	SDI00			MSC0 input
	P11.10	O0		General-purpose output
	TOUT99	O1		GTM output
	–	O2		Reserved
	SLSO03	O3		QSPI0 output
	SLSO13	O4		QSPI1 output
	–	O5		Reserved
	–	O6		Reserved
	CC62	O7		CCU60 output
A8	P11.11	I	MP+ / PU1 / VFLEX	General-purpose input
	TIN100			GTM input
	ETHCRSDVA			ETH input
	ETHRXDVA			ETH input
	ETHCRSB			ETH input
	P11.11	O0		General-purpose output
	TOUT100	O1		GTM output
	END02	O2		MSC0 output
	SLSO04	O3		QSPI0 output
	SLSO14	O4		QSPI1 output
	EN00	O5		MSC0 output
	TXENB	O6		ERAY output
	CC61	O7		CCU60 output

## Package and Pinning Definitions TC277x Pin Definition and Functions:

Table 2-23 Port 11 Functions (cont'd)

Pin	Symbol	Ctrl	Type	Function
<b>B8</b>	P11.12	I	<b>MPR / PU1 / VFLEX</b>	General-purpose input
	TIN101	O0		GTM input
	ETHREFCLK			ETH input
	ETHTXCLKB			ETH input (Not for productive purposes)
	P11.12			General-purpose output
	TOUT101	O1		GTM output
	ATX1	O2		ASCLIN1 output
	GTMCLK2	O3		GTM output
	TXDB	O4		ERAY output
	TXDCAN3	O5		CAN node 3 output
	EXTCLK1	O6		SCU output
	CC60	O7		CCU60 output
<b>E6</b>	P11.13	I	<b>LP / PU1 / VFLEX</b>	General-purpose input
	TIN125			GTM input
	ETHRXERA			ETH input
	P11.13	O0		General-purpose output
	TOUT125	O1		GTM output
	–	O2		Reserved
	–	O3		Reserved
	–	O4		Reserved
	–	O5		Reserved
	–	O6		Reserved
	–	O7		Reserved
	<b>D7</b>	P11.14		I
TIN126			GTM input	
ETHCRSDVB			ETH input	
ETHRXDVB			ETH input	
ETHCRSA			ETH input	
P11.14		O0	General-purpose output	
TOUT126		O1	GTM output	
–		O2	Reserved	
–		O3	Reserved	
–		O4	Reserved	
–		O5	Reserved	
–		O6	Reserved	
–	O7	Reserved		

## Package and Pinning Definitions TC277x Pin Definition and Functions:

Table 2-23 Port 11 Functions (cont'd)

Pin	Symbol	Ctrl	Type	Function
D6	P11.15	I	LP / PU1 / VFLEX	General-purpose input
	TIN127			GTM input
	ETHCOL			ETH input
	P11.15	O0		General-purpose output
	TOUT127	O1		GTM output
	—	O2		Reserved
	—	O3		Reserved
	—	O4		Reserved
	—	O5		Reserved
	—	O6		Reserved
	—	O7		Reserved

Table 2-24 Port 12 Functions

Pin	Symbol	Ctrl	Type	Function
E12	P12.0	I	LP / PU1 / VFLEX	General-purpose input
	TIN128			GTM input
	ETHRXCLKC			ETH input
	RXDCAN0C			CAN node 0 input
	P12.0	O0		General-purpose output
	TOUT128	O1		GTM output
	—	O2		Reserved
	—	O3		Reserved
	—	O4		Reserved
	—	O5		Reserved
	ETHMDC	O6		ETH output
—	O7	Reserved		
E11	P12.1	I	LP / PU1 / VFLEX	General-purpose input
	TIN129			GTM input
	P12.1	O0		General-purpose output
	TOUT129	O1		GTM output
	ASLSO3	O2		ASCLIN3 output
	—	O3		Reserved
	—	O4		Reserved
	TXDCAN0	O5		CAN node 0 output
	—	O6		Reserved
	—	O7		Reserved
	ETHMDIOC	HWOUT		ETH input/output

**Package and Pinning Definitions TC277x Pin Definition and Functions:**
**Table 2-25 Port 13 Functions**

Pin	Symbol	Ctrl	Type	Function
<b>B12</b>	P13.0	I	<b>LVDSM_N / PU1 / VEXT</b>	General-purpose input
	TIN91			GTM input
	P13.0	O0		General-purpose output
	TOUT91	O1		GTM output
	END03	O2		MSC0 output
	SCLK2N	O3		QSPI2 output (LVDS)
	EN01	O4		MSC0 output
	FCLN0	O5		MSC0 output (LVDS)
	FCLND0	O6		MSC0 output (LVDS)
	–	O7		Reserved
<b>A12</b>	P13.1	I	<b>LVDSM_P / PU1 / VEXT</b>	General-purpose input
	TIN92			GTM input
	SCL0B			I2C0 input
	P13.1	O0		General-purpose output
	TOUT92	O1		GTM output
	–	O2		Reserved
	SCLK2P	O3		QSPI2 output (LVDS)
	–	O4		Reserved
	FCLP0	O5		MSC0 output (LVDS)
	SCL0	O6		I2C0 output
	–	O7		Reserved
<b>B11</b>	P13.2	I	<b>LVDSM_N / PU1 / VEXT</b>	General-purpose input
	TIN93			GTM input
	CAPINA			GPT120 input
	SDA0B			I2C0 input
	P13.2	O0		General-purpose output
	TOUT93	O1		GTM output
	–	O2		Reserved
	MTSR2N	O3		QSPI2 output (LVDS)
	FCLP0	O4		MSC0 output
	SON0	O5		MSC0 output (LVDS)
	SDA0	O6		I2C0 output
	SOND0	O7		MSC0 output (LVDS)

## Package and Pinning Definitions TC277x Pin Definition and Functions:

Table 2-25 Port 13 Functions (cont'd)

Pin	Symbol	Ctrl	Type	Function
A11	P13.3	I	LVDSM_P / PU1 / VEXT	General-purpose input
	TIN94			GTM input
	P13.3	O0		General-purpose output
	TOUT94	O1		GTM output
	–	O2		Reserved
	MTSR2P	O3		QSPI2 output (LVDS)
	–	O4		Reserved
	SOP0	O5		MSC0 output (LVDS)
	–	O6		Reserved
	–	O7		Reserved

Table 2-26 Port 14 Functions

Pin	Symbol	Ctrl	Type	Function
B16	P14.0	I	MP+ / PU1 / VEXT	General-purpose input
	TIN80			GTM input
	P14.0	O0		General-purpose output
	TOUT80	O1		GTM output
	ATX0	O2		ASCLIN0 output Recommended as Boot loader pin.
	TXDA	O3		ERAY output
	TXDB	O4		ERAY output
	TXDCAN1	O5		CAN node 1 output Used for single pin DAP (SPD) function.
	ASCLK0	O6		ASCLIN0 output
	COU62	O7		CCU60 output

## Package and Pinning Definitions TC277x Pin Definition and Functions:

Table 2-26 Port 14 Functions (cont'd)

Pin	Symbol	Ctrl	Type	Function
<b>A15</b>	P14.1	I	<b>MP / PU1 / VEXT</b>	General-purpose input
	TIN81			GTM input
	REQ15			SCU input
	ARX0A			ASCLIN0 input Recommended as Boot loader pin.
	RXDCAN1B			CAN node 1 input Used for single pin DAP (SPD) function.
	RXDA3			ERAY input
	RXDB3			ERAY input
	EVRWUPA			SCU input
	P14.1	O0		General-purpose output
	TOUT81	O1		GTM output
	ATX0	O2		ASCLIN0 output
	–	O3		Reserved
	–	O4		Reserved
	–	O5		Reserved
	–	O6		Reserved
	COUT63	O7		CCU60 output
<b>E13</b>	P14.2	I	<b>LP / PU1 / VEXT</b>	General-purpose input
	TIN82			GTM input
	HWCFG2 EVR13			SCU input Latched at cold power on reset to decide EVR13 activation.
	P14.2			O0
	TOUT82	O1		GTM output
	ATX2	O2		ASCLIN2 output
	SLSO21	O3		QSPI2 output
	–	O4		Reserved
	–	O5		Reserved
	ASCLK2	O6		ASCLIN2 output
	–	O7		Reserved

## Package and Pinning Definitions TC277x Pin Definition and Functions:

Table 2-26 Port 14 Functions (cont'd)

Pin	Symbol	Ctrl	Type	Function
<b>B14</b>	P14.3	I	<b>LP / PU1 / VEXT</b>	General-purpose input
	TIN83			GTM input
	ARX2A			ASCLIN2 input
	REQ10			SCU input
	HWCFG3_BMI			SCU input
	SDI02			MSC0 input
	P14.3			O0
	TOUT83	O1		GTM output
	ATX2	O2		ASCLIN2 output
	SLSO23	O3		QSPI2 output
	ASLSO1	O4		ASCLIN1 output
	ASLSO3	O5		ASCLIN3 output
	–	O6		Reserved
	–	O7		Reserved
<b>B15</b>	P14.4	I	<b>LP / PU1 / VEXT</b>	General-purpose input
	TIN84			GTM input
	HWCFG6			SCU input Latched at cold power on reset to decide default pad reset state (PU or HighZ).
	P14.4	O0		General-purpose output
	TOUT84	O1		GTM output
	–	O2		Reserved
	–	O3		Reserved
	–	O4		Reserved
	–	O5		Reserved
	–	O6		Reserved
–	O7	Reserved		

## Package and Pinning Definitions TC277x Pin Definition and Functions:

Table 2-26 Port 14 Functions (cont'd)

Pin	Symbol	Ctrl	Type	Function
<b>A14</b>	P14.5	I	<b>MP+ / PU1 / VEXT</b>	General-purpose input
	TIN85			GTM input
	HWCFG1 EVR33			SCU input Latched at cold power on reset to decide EVR33 activation.
	P14.5	O0		General-purpose output
	TOUT85	O1		GTM output
	—	O2		Reserved
	—	O3		Reserved
	—	O4		Reserved
	—	O5		Reserved
	TXDB	O6		ERAY output
—	O7	Reserved		
<b>B13</b>	P14.6	I	<b>MP+ / PU1 / VEXT</b>	General-purpose input
	TIN86			GTM input
	HWCFG0 DCLDO			SCU input If EVR13 active, latched at cold power on reset to decide between LDO and SMPS mode.
	P14.6	O0		General-purpose output
	TOUT86	O1		GTM output
	—	O2		Reserved
	SLSO22	O3		QSPI2 output
	—	O4		Reserved
	—	O5		Reserved
	TXENB	O6		ERAY output
—	O7	Reserved		
<b>D13</b>	P14.7	I	<b>LP / PU1 / VEXT</b>	General-purpose input
	TIN87			GTM input
	RXDB0			ERAY input
	P14.7	O0		General-purpose output
	TOUT87	O1		GTM output
	ARTS0	O2		ASCLIN0 output
	SLSO24	O3		QSPI2 output
	—	O4		Reserved
	—	O5		Reserved
	—	O6		Reserved
—	O7	Reserved		

## Package and Pinning Definitions TC277x Pin Definition and Functions:

Table 2-26 Port 14 Functions (cont'd)

Pin	Symbol	Ctrl	Type	Function
A13	P14.8	I	LP / PU1 / VEXT	General-purpose input
	TIN88			GTM input
	ARX1D			ASCLIN1 input
	RXDCAN2D			CAN node 2 input
	RXDA0			ERAY input
	P14.8	O0		General-purpose output
	TOUT88	O1		GTM output
	–	O2		Reserved
	–	O3		Reserved
	–	O4		Reserved
	–	O5		Reserved
	–	O6		Reserved
	–	O7		Reserved
D12	P14.9	I	MP+ / PU1 / VEXT	General-purpose input
	TIN89			GTM input
	ACTS0A			ASCLIN0 input
	P14.9	O0		General-purpose output
	TOUT89	O1		GTM output
	END03	O2		MSC0 output
	EN01	O3		MSC0 output
	–	O4		Reserved
	$\overline{\text{TXENB}}$	O5		ERAY output
	$\overline{\text{TXENA}}$	O6		ERAY output
	–	O7		Reserved
D11	P14.10	I	MP+ / PU1 / VEXT	General-purpose input
	TIN90			GTM input
	P14.10	O0		General-purpose output
	TOUT90	O1		GTM output
	END02	O2		MSC0 output
	EN00	O3		MSC0 output
	ATX1	O4		ASCLIN1 output
	TXDCAN2	O5		CAN node 2 output
	TXDA	O6		ERAY output
	–	O7		Reserved

## Package and Pinning Definitions TC277x Pin Definition and Functions:

Table 2-27 Port 15 Functions

Pin	Symbol	Ctrl	Type	Function
<b>B20</b>	P15.0	I	<b>LP / PU1 / VEXT</b>	General-purpose input
	TIN71			GTM input
	P15.0	O0		General-purpose output
	TOUT71	O1		GTM output
	ATX1	O2		ASCLIN1 output
	SLSO013	O3		QSPI0 output
	–	O4		Reserved
	TXDCAN2	O5		CAN node 2 output
	ASCLK1	O6		ASCLIN1 output
	–	O7		Reserved
<b>A18</b>	P15.1	I	<b>LP / PU1 / VEXT</b>	General-purpose input
	TIN72			GTM input
	REQ16			SCU input
	ARX1A			ASCLIN1 input
	RXDCAN2A			CAN node 2 input
	SLSI2B			QSPI2 input
	EVRWUPB			SCU input
	P15.1	O0		General-purpose output
	TOUT72	O1		GTM output
	ATX1	O2		ASCLIN1 output
	SLSO25	O3		QSPI2 output
	–	O4		Reserved
	–	O5		Reserved
	–	O6		Reserved
	–	O7		Reserved
<b>C19</b>	P15.2	I	<b>MP / PU1 / VEXT</b>	General-purpose input
	TIN73			GTM input
	SLSI2A			QSPI2 input
	MRST2E			QSPI2 input
	P15.2	O0		General-purpose output
	TOUT73	O1		GTM output
	ATX0	O2		ASCLIN0 output
	SLSO20	O3		QSPI2 output
	–	O4		Reserved
	TXDCAN1	O5		CAN node 1 output
	ASCLK0	O6		ASCLIN0 output
	–	O7		Reserved

## Package and Pinning Definitions TC277x Pin Definition and Functions:

Table 2-27 Port 15 Functions (cont'd)

Pin	Symbol	Ctrl	Type	Function
<b>B17</b>	P15.3	I	<b>MP / PU1 / VEXT</b>	General-purpose input
	TIN74			GTM input
	ARX0B			ASCLIN0 input
	SCLK2A			QSPI2 input
	RXDCAN1A			CAN node 1 input
	P15.3	O0		General-purpose output
	TOUT74	O1		GTM output
	ATX0	O2		ASCLIN0 output
	SCLK2	O3		QSPI2 output
	END03	O4		MSC0 output
	EN01	O5		MSC0 output
	–	O6		Reserved
	–	O7		Reserved
	<b>A17</b>	P15.4		I
TIN75		GTM input		
MRST2A		QSPI2 input		
REQ0		SCU input		
SCL0C		I2C0 input		
P15.4		O0	General-purpose output	
TOUT75		O1	GTM output	
ATX1		O2	ASCLIN1 output	
MRST2		O3	QSPI2 output	
–		O4	Reserved	
–		O5	Reserved	
SCL0		O6	I2C0 output	
CC62		O7	CCU60 output	

## Package and Pinning Definitions TC277x Pin Definition and Functions:

Table 2-27 Port 15 Functions (cont'd)

Pin	Symbol	Ctrl	Type	Function
<b>E14</b>	P15.5	I	<b>MP / PU1 / VEXT</b>	General-purpose input
	TIN76			GTM input
	ARX1B			ASCLIN1 input
	MTSR2A			QSPI2 input
	REQ13			SCU input
	SDA0C			I2C0 input
	P15.5			O0
	TOUT76	O1		GTM output
	ATX1	O2		ASCLIN1 output
	MTSR2	O3		QSPI2 output
	END02	O4		MSC0 output
	EN00	O5		MSC0 output
	SDA0	O6		I2C0 output
	CC61	O7		CCU60 output
<b>A16</b>	P15.6	I	<b>MP / PU1 / VEXT</b>	General-purpose input
	TIN77			GTM input
	MTSR2B			QSPI2 input
	P15.6	O0		General-purpose output
	TOUT77	O1		GTM output
	ATX3	O2		ASCLIN3 output
	MTSR2	O3		QSPI2 output
	–	O4		Reserved
	SCLK2	O5		QSPI2 output
	ASCLK3	O6		ASCLIN3 output
CC60	O7	CCU60 output		
<b>D15</b>	P15.7	I	<b>MP / PU1 / VEXT</b>	General-purpose input
	TIN78			GTM input
	ARX3A			ASCLIN3 input
	MRST2B			QSPI2 input
	P15.7	O0		General-purpose output
	TOUT78	O1		GTM output
	ATX3	O2		ASCLIN3 output
	MRST2	O3		QSPI2 output
	–	O4		Reserved
	–	O5		Reserved
	–	O6		Reserved
	COUT60	O7		CCU60 output

## Package and Pinning Definitions TC277x Pin Definition and Functions:

Table 2-27 Port 15 Functions (cont'd)

Pin	Symbol	Ctrl	Type	Function
D14	P15.8	I	MP / PU1 / VEXT	General-purpose input
	TIN79			GTM input
	SCLK2B			QSPI2 input
	REQ1			SCU input
	P15.8	O0		General-purpose output
	TOUT79	O1		GTM output
	–	O2		Reserved
	SCLK2	O3		QSPI2 output
	–	O4		Reserved
	–	O5		Reserved
	ASCLK3	O6		ASCLIN3 output
	COU61	O7		CCU60 output

Table 2-28 Port 20 Functions

Pin	Symbol	Ctrl	Type	Function
H20	P20.0	I	MP / PU1 / VEXT	General-purpose input
	TIN59			GTM input
	RXDCAN3C			CAN node 3 input
	T6EUDA			GPT120 input
	REQ9			SCU input
	SYSCLK			HSCT input
	TGI0			OCDS input
	P20.0			O0
	TOUT59	O1		GTM output
	ATX3	O2		ASCLIN3 output
	ASCLK3	O3		ASCLIN3 output
	–	O4		Reserved
	SYSCLK	O5		HSCT output
	–	O6		Reserved
	–	O7		Reserved
	TGO0	HWOUT		OCDS; ENx

## Package and Pinning Definitions TC277x Pin Definition and Functions:

Table 2-28 Port 20 Functions (cont'd)

Pin	Symbol	Ctrl	Type	Function
<b>G19</b>	P20.1	I	<b>LP / PU1 / VEXT</b>	General-purpose input
	TIN60			GTM input
	TGI1			OCDS input
	P20.1	O0		General-purpose output
	TOUT60	O1		GTM output
	—	O2		Reserved
	—	O3		Reserved
	—	O4		Reserved
	—	O5		Reserved
	—	O6		Reserved
	—	O7		Reserved
	TGO1	HWOU T		OCDS; ENx
<b>H19</b>	P20.2	I	<b>LP / PU / VEXT</b>	General-purpose input This pin is latched at power on reset release to enter test mode.
	TESTMODE			OCDS input
	P20.2	O0		Output function not available
	—	O1		Output function not available
	—	O2		Output function not available
	—	O3		Output function not available
	—	O4		Output function not available
	—	O5		Output function not available
	—	O6		Output function not available
	—	O7		Output function not available
<b>G20</b>	P20.3	I	<b>LP / PU1 / VEXT</b>	General-purpose input
	TIN61			GTM input
	T6INA			GPT120 input
	ARX3C			ASCLIN3 input
	P20.3	O0		General-purpose output
	TOUT61	O1		GTM output
	ATX3	O2		ASCLIN3 output
	SLSO09	O3		QSPI0 output
	SLSO29	O4		QSPI2 output
	TXDCAN3	O5		CAN node 3 output
	—	O6		Reserved
	—	O7		Reserved

## Package and Pinning Definitions TC277x Pin Definition and Functions:

Table 2-28 Port 20 Functions (cont'd)

Pin	Symbol	Ctrl	Type	Function
F17	P20.6	I	LP / PU1 / VEXT	General-purpose input
	TIN62			GTM input
	P20.6	O0		General-purpose output
	TOUT62	O1		GTM output
	ARTS1	O2		ASCLIN1 output
	SLSO08	O3		QSPI0 output
	SLSO28	O4		QSPI2 output
	–	O5		Reserved
	WDT2LCK	O6		SCU output
	–	O7		Reserved
F19	P20.7	I	LP / PU1 / VEXT	General-purpose input
	TIN63			GTM input
	ACTS1A			ASCLIN1 input
	RXDCAN0B			CAN node 0 input
	P20.7	O0		General-purpose output
	TOUT63	O1		GTM output
	–	O2		Reserved
	–	O3		Reserved
	–	O4		Reserved
	–	O5		Reserved
	WDT1LCK	O6		SCU output
	COU63	O7		CCU61 output
F20	P20.8	I	MP / PU1 / VEXT	General-purpose input
	TIN64			GTM input
	P20.8	O0		General-purpose output
	TOUT64	O1		GTM output
	ASLSO1	O2		ASCLIN1 output
	SLSO00	O3		QSPI0 output
	SLSO10	O4		QSPI1 output
	TXDCAN0	O5		CAN node 0 output
	WDT0LCK	O6		SCU output
	CC60	O7		CCU61 output

## Package and Pinning Definitions TC277x Pin Definition and Functions:

Table 2-28 Port 20 Functions (cont'd)

Pin	Symbol	Ctrl	Type	Function
E17	P20.9	I	LP / PU1 / VEXT	General-purpose input
	TIN65			GTM input
	ARX1C			ASCLIN1 input
	RXDCAN3E			CAN node 3 input
	REQ11			SCU input
	SLSI0B			QSPI0 input
	P20.9			O0
	TOUT65	O1		GTM output
	–	O2		Reserved
	SLSO01	O3		QSPI0 output
	SLSO11	O4		QSPI1 output
	–	O5		Reserved
	WDTSLCK	O6		SCU output
	CC61	O7		CCU61 output
E19	P20.10	I	MP / PU1 / VEXT	General-purpose input
	TIN66			GTM input
	P20.10	O0		General-purpose output
	TOUT66	O1		GTM output
	ATX1	O2		ASCLIN1 output
	SLSO06	O3		QSPI0 output
	SLSO27	O4		QSPI2 output
	TXDCAN3	O5		CAN node 3 output
	ASCLK1	O6		ASCLIN1 output
	CC62	O7		CCU61 output
E20	P20.11	I	MP / PU1 / VEXT	General-purpose input
	TIN67			GTM input
	SCLK0A			QSPI0 input
	P20.11	O0		General-purpose output
	TOUT67	O1		GTM output
	–	O2		Reserved
	SCLK0	O3		QSPI0 output
	–	O4		Reserved
	–	O5		Reserved
	–	O6		Reserved
	COU60	O7		CCU61 output

## Package and Pinning Definitions TC277x Pin Definition and Functions:

Table 2-28 Port 20 Functions (cont'd)

Pin	Symbol	Ctrl	Type	Function
<b>D19</b>	P20.12	I	<b>MP / PU1 / VEXT</b>	General-purpose input
	TIN68			GTM input
	MRST0A			QSPI0 input
	P20.12	O0		General-purpose output
	TOUT68	O1		GTM output
	–	O2		Reserved
	MRST0	O3		QSPI0 output
	MTRSR0	O4		QSPI0 output
	–	O5		Reserved
	–	O6		Reserved
COU61	O7	CCU61 output		
<b>D20</b>	P20.13	I	<b>MP / PU1 / VEXT</b>	General-purpose input
	TIN69			GTM input
	SLSI0A			QSPI0 input
	P20.13	O0		General-purpose output
	TOUT69	O1		GTM output
	–	O2		Reserved
	SLSO02	O3		QSPI0 output
	SLSO12	O4		QSPI1 output
	SCLK0	O5		QSPI0 output
	–	O6		Reserved
COU62	O7	CCU61 output		
<b>C20</b>	P20.14	I	<b>MP / PU1 / VEXT</b>	General-purpose input
	TIN70			GTM input
	MTRSR0A			QSPI0 input
	P20.14	O0		General-purpose output
	TOUT70	O1		GTM output
	–	O2		Reserved
	MTRSR0	O3		QSPI0 output
	–	O4		Reserved
	–	O5		Reserved
	–	O6		Reserved
–	O7	Reserved		

## Package and Pinning Definitions TC277x Pin Definition and Functions:

Table 2-29 Port 21 Functions

Pin	Symbol	Ctrl	Type	Function
K17	P21.0	I	A2 / PU1 / VDDP3	General-purpose input
	TIN51			GTM input
	P21.0	O0		General-purpose output
	TOUT51	O1		GTM output
	—	O2		Reserved
	—	O3		Reserved
	—	O4		Reserved
	—	O5		Reserved
	ETHMDC	O6		ETH output
	—	O7		Reserved
	HSM1	HWOUT		HSM output 1
J17	P21.1	I	A2 / PU1 / VDDP3	General-purpose input
	TIN52			GTM input
	ETHMDIOB			ETH input (Not for production purposes)
	P21.1	O0		General-purpose output
	TOUT52	O1		GTM output
	—	O2		Reserved
	—	O3		Reserved
	—	O4		Reserved
	—	O5		Reserved
	ETHMDIO	O6		ETH output (Not for production purposes)
	—	O7		Reserved
HSM2	HWOUT	HSM output 2		

## Package and Pinning Definitions TC277x Pin Definition and Functions:

Table 2-29 Port 21 Functions (cont'd)

Pin	Symbol	Ctrl	Type	Function	
<b>K19</b>	P21.2	I	<b>LVDSH_N/ PU1 / VDDP3</b>	General-purpose input	
	TIN53			GTM input	
	MRST2CN			QSPI2 input (LVDS)	
	MRST3FN			QSPI3 input (LVDS)	
	ARX3GN			ASCLIN3 input (LVDS)	
	EMGSTOPB			SCU input	
	RXDN			HSCT input (LVDS)	
	P21.2			O0	General-purpose output
	TOUT53	O1		GTM output	
	ASLSO3	O2		ASCLIN3 output	
	–	O3		Reserved	
	–	O4		Reserved	
	ETHMDC	O5		ETH output	
	–	O6		Reserved	
	–	O7		Reserved	
<b>J19</b>	P21.3	I	<b>LVDSH_P/ PU1 / VDDP3</b>	General-purpose input	
	TIN54			GTM input	
	MRST2CP			QSPI2 input (LVDS)	
	MRST3FP			QSPI3 input (LVDS)	
	ARX3GP			ASCLIN3 input (LVDS)	
	RXDP			HSCT input (LVDS)	
	P21.3			O0	General-purpose output
	TOUT54			O1	GTM output
	–	O2		Reserved	
	–	O3		Reserved	
	–	O4		Reserved	
	–	O5		Reserved	
	–	O6		Reserved	
	–	O7		Reserved	
	ETHMDIOD	HWOUT		ETH input/output	

## Package and Pinning Definitions TC277x Pin Definition and Functions:

Table 2-29 Port 21 Functions (cont'd)

Pin	Symbol	Ctrl	Type	Function
<b>K20</b>	P21.4	I	<b>LVDSH_N/ PU1 / VDDP3</b>	General-purpose input
	TIN55			GTM input
	P21.4	O0		General-purpose output
	TOUT55	O1		GTM output
	–	O2		Reserved
	–	O3		Reserved
	–	O4		Reserved
	–	O5		Reserved
	–	O6		Reserved
	–	O7		Reserved
	TXDN	HSCT		HSCT output (LVDS)
<b>J20</b>	P21.5	I	<b>LVDSH_P/ PU1 / VDDP3</b>	General-purpose input
	TIN56			GTM input
	P21.5	O0		General-purpose output
	TOUT56	O1		GTM output
	ASCLK3	O2		ASCLIN3 output
	–	O3		Reserved
	–	O4		Reserved
	–	O5		Reserved
	–	O6		Reserved
	–	O7		Reserved
	TXDP	HSCT		HSCT output (LVDS)
<b>H17</b>	P21.6	I	<b>A2 / PU / VDDP3</b>	General-purpose input
	TIN57			GTM input
	ARX3F			ASCLIN3 input
	$\overline{\text{TGI2}}$			OCDS input
	TDI			OCDS (JTAG) input
	T5EUDA			GPT120 input
	P21.6	O0		General-purpose output
	TOUT57	O1		GTM output
	ASLSO3	O2		ASCLIN3 output
	–	O3		Reserved
	–	O4		Reserved
	SYSCLK	O5		HSCT output
	–	O6		Reserved
	T3OUT	O7		GPT120 output
	$\overline{\text{TGO2}}$	HWOUT		OCDS; ENx

**Package and Pinning Definitions TC277x Pin Definition and Functions:**
**Table 2-29 Port 21 Functions (cont'd)**

Pin	Symbol	Ctrl	Type	Function
<b>H16</b>	P21.7	I	<b>A2 / PU / VDDP3</b>	General-purpose input
	TIN58			GTM input
	DAP2			OCDS input
	TGI3			OCDS input
	TDO			OCDS (JTAG) input The JTAG TDO function is overlaid with P21.7 via a double bond. In JTAG mode this pin is used as TDO, after power-on reset it is HighZ. In DAP mode this pin is used as P21.7 and controlled by the related port control logic
	ETHRXERB			ETH input
	T5INA			GPT120 input
	P21.7			O0
	TOUT58	O1	GTM output	
	ATX3	O2	ASCLIN3 output	
	ASCLK3	O3	ASCLIN3 output	
	–	O4	Reserved	
	–	O5	Reserved	
	–	O6	Reserved	
	T6OUT	O7	GPT120 output	
	TGO3	HWOU T	OCDS; ENx	
TDO	OCDS (JTAG); ENx The JTAG TDO function is overlaid with P21.7 via a double bond. In JTAG mode this pin is used as TDO, after power-on reset it is HighZ. In DAP mode this pin is used as P21.7 and controlled by the related port control logic			

**Package and Pinning Definitions TC277x Pin Definition and Functions:**
**Table 2-30 Port 22 Functions**

Pin	Symbol	Ctrl	Type	Function
<b>P20</b>	P22.0	I	<b>LVDSM_N / PU1 / VEXT</b>	General-purpose input
	TIN47			GTM input
	MTSR3E			QSPI3 input
	P22.0	O0		General-purpose output
	TOUT47	O1		GTM output
	ATX3N	O2		ASCLIN3 output (LVDS)
	MTSR3	O3		QSPI3 output
	SCLK3N	O4		QSPI3 output (LVDS)
	FCLN1	O5		MSC1 output (LVDS)
	FCLND1	O6		MSC1 output (LVDS)
	–	O7		Reserved
<b>P19</b>	P22.1	I	<b>LVDSM_P / PU1 / VEXT</b>	General-purpose input
	TIN48			GTM input
	MRST3E			QSPI3 input
	P22.1	O0		General-purpose output
	TOUT48	O1		GTM output
	ATX3P	O2		ASCLIN3 output (LVDS)
	MRST3	O3		QSPI3 output
	SCLK3P	O4		QSPI3 output (LVDS)
	FCLP1	O5		MSC1 output (LVDS)
	–	O6		Reserved
	–	O7		Reserved
<b>R20</b>	P22.2	I	<b>LVDSM_N / PU1 / VEXT</b>	General-purpose input
	TIN49			GTM input
	SLSI3D			QSPI3 input
	P22.2	O0		General-purpose output
	TOUT49	O1		GTM output
	–	O2		Reserved
	SLSO312	O3		QSPI3 output
	MTSR3N	O4		QSPI3 output (LVDS)
	SON1	O5		MSC1 output (LVDS)
	SOND1	O6		MSC1 output (LVDS)
	–	O7		Reserved

## Package and Pinning Definitions TC277x Pin Definition and Functions:

Table 2-30 Port 22 Functions (cont'd)

Pin	Symbol	Ctrl	Type	Function
R19	P22.3	I	LVDSM_P / PU1 / VEXT	General-purpose input
	TIN50			GTM input
	SCLK3E			QSPI3 input
	P22.3	O0		General-purpose output
	TOUT50	O1		GTM output
	–	O2		Reserved
	SCLK3	O3		QSPI3 output
	MTSR3P	O4		QSPI3 output (LVDS)
	SOP1	O5		MSC1 output (LVDS)
	–	O6		Reserved
	–	O7		Reserved
P16	P22.4	I	LP / PU1 / VEXT	General-purpose input
	TIN130			GTM input
	P22.4			General-purpose output
	TOUT130	O1		GTM output
	–	O2		Reserved
	–	O3		Reserved
	SLSO012	O4		QSPI0 output
	–	O5		Reserved
	–	O6		Reserved
	–	O7		Reserved
	P17	P22.5		I
TIN131		GTM input		
MTSR0C		QSPI0 input		
P22.5		O0	General-purpose output	
TOUT131		O1	GTM output	
–		O2	Reserved	
–		O3	Reserved	
MTSR0		O4	QSPI0 output	
–		O5	Reserved	
–		O6	Reserved	
–		O7	Reserved	

## Package and Pinning Definitions TC277x Pin Definition and Functions:

Table 2-30 Port 22 Functions (cont'd)

Pin	Symbol	Ctrl	Type	Function
<b>N16</b>	P22.6	I	<b>LP / PU1 / VEXT</b>	General-purpose input
	TIN132			GTM input
	MRST0C			QSPIO input
	P22.6	O0		General-purpose output
	TOUT132	O1		GTM output
	—	O2		Reserved
	—	O3		Reserved
	MRST0	O4		QSPIO output
	—	O5		Reserved
	—	O6		Reserved
—	O7	Reserved		
<b>N17</b>	P22.7	I	<b>LP / PU1 / VEXT</b>	General-purpose input
	TIN133			GTM input
	SCLK0C			QSPIO input
	P22.7	O0		General-purpose output
	TOUT133	O1		GTM output
	—	O2		Reserved
	—	O3		Reserved
	SCLK0	O4		QSPIO output
	—	O5		Reserved
	—	O6		Reserved
—	O7	Reserved		
<b>M16</b>	P22.8	I	<b>LP / PU1 / VEXT</b>	General-purpose input
	TIN134			GTM input
	SCLK0B			QSPIO input
	P22.8	O0		General-purpose output
	TOUT134	O1		GTM output
	—	O2		Reserved
	—	O3		Reserved
	SCLK0	O4		QSPIO output
	—	O5		Reserved
	—	O6		Reserved
—	O7	Reserved		

## Package and Pinning Definitions TC277x Pin Definition and Functions:

Table 2-30 Port 22 Functions (cont'd)

Pin	Symbol	Ctrl	Type	Function
<b>M17</b>	P22.9	I	<b>LP / PU1 / VEXT</b>	General-purpose input
	TIN135			GTM input
	MRST0B			QSPI0 input
	P22.9	O0		General-purpose output
	TOUT135	O1		GTM output
	—	O2		Reserved
	—	O3		Reserved
	MRST0	O4		QSPI0 output
	—	O5		Reserved
	—	O6		Reserved
—	O7	Reserved		
<b>L16</b>	P22.10	I	<b>LP / PU1 / VEXT</b>	General-purpose input
	TIN136			GTM input
	MTSR0B			QSPI0 input
	P22.10	O0		General-purpose output
	TOUT136	O1		GTM output
	—	O2		Reserved
	—	O3		Reserved
	MTSR0	O4		QSPI0 output
	—	O5		Reserved
	—	O6		Reserved
—	O7	Reserved		
<b>L17</b>	P22.11	I	<b>LP / PU1 / VEXT</b>	General-purpose input
	TIN137			GTM input
	P22.11			O0
	TOUT137	O1		GTM output
	—	O2		Reserved
	—	O3		Reserved
	SLSO010	O4		QSPI0 output
	—	O5		Reserved
	—	O6		Reserved
	—	O7		Reserved

## Package and Pinning Definitions TC277x Pin Definition and Functions:

Table 2-31 Port 23 Functions

Pin	Symbol	Ctrl	Type	Function
<b>V20</b>	P23.0	I	<b>LP / PU1 / VEXT</b>	General-purpose input
	TIN41			GTM input
	P23.0	O0		General-purpose output
	TOUT41	O1		GTM output
	—	O2		Reserved
	—	O3		Reserved
	—	O4		Reserved
	—	O5		Reserved
	—	O6		Reserved
	—	O7		Reserved
<b>U19</b>	P23.1	I	<b>MP+ / PU1 / VEXT</b>	General-purpose input
	TIN42			GTM input
	SDI10			MSC1 input
	P23.1	O0		General-purpose output
	TOUT42	O1		GTM output
	ARTS1	O2		ASCLIN1 output
	SLSO313	O3		QSPI3 output
	GTMCLK0	O4		GTM output
	—	O5		Reserved
	EXTCLK0	O6		SCU output
—	O7	Reserved		
<b>U20</b>	P23.2	I	<b>LP / PU1 / VEXT</b>	General-purpose input
	TIN43			GTM input
	P23.2	O0		General-purpose output
	TOUT43	O1		GTM output
	—	O2		Reserved
	—	O3		Reserved
	—	O4		Reserved
	—	O5		Reserved
	—	O6		Reserved
	—	O7		Reserved

## Package and Pinning Definitions TC277x Pin Definition and Functions:

Table 2-31 Port 23 Functions (cont'd)

Pin	Symbol	Ctrl	Type	Function
T19	P23.3	I	LP / PU1 / VEXT	General-purpose input
	TIN44			GTM input
	INJ10			MSC1 input
	P23.3	O0		General-purpose output
	TOUT44	O1		GTM output
	—	O2		Reserved
	—	O3		Reserved
	—	O4		Reserved
	—	O5		Reserved
	—	O6		Reserved
—	O7	Reserved		
T20	P23.4	I	MP+ / PU1 / VEXT	General-purpose input
	TIN45			GTM input
	P23.4			O0
	TOUT45	O1		GTM output
	—	O2		Reserved
	SLSO35	O3		QSPI3 output
	END12	O4		MSC1 output
	EN10	O5		MSC1 output
	—	O6		Reserved
	—	O7		Reserved
T17	P23.5	I	MP+ / PU1 / VEXT	General-purpose input
	TIN46			GTM input
	P23.5			O0
	TOUT46	O1		GTM output
	—	O2		Reserved
	SLSO34	O3		QSPI3 output
	END13	O4		MSC1 output
	EN11	O5		MSC1 output
	—	O6		Reserved
	—	O7		Reserved

## Package and Pinning Definitions TC277x Pin Definition and Functions:

Table 2-31 Port 23 Functions (cont'd)

Pin	Symbol	Ctrl	Type	Function
R17	P23.6	I	LP / PU1 / VEXT	General-purpose input
	TIN138			GTM input
	P23.6	O0		General-purpose output
	TOUT138	O1		GTM output
	—	O2		Reserved
	—	O3		Reserved
	SLSO011	O4		QSPI0 output
	—	O5		Reserved
	—	O6		Reserved
	—	O7		Reserved
R16	P23.7	I	LP / PU1 / VEXT	General-purpose input
	TIN139			GTM input
	P23.7	O0		General-purpose output
	TOUT139	O1		GTM output
	—	O2		Reserved
	—	O3		Reserved
	—	O4		Reserved
	—	O5		Reserved
	—	O6		Reserved
	—	O7		Reserved

Table 2-32 Port 32 Functions

Pin	Symbol	Ctrl	Type	Function
Y17	P32.0	I	LP / EVR13 SMPS -> PD, GPIO -> PU / VEXT	General-purpose input
	TIN36			GTM input
	FDEST			PMU input
	VGATE1N			SMPS mode: analog output. External Pass Device gate control for EVR13
	P32.0	O0		General-purpose output
	TOUT36	O1		GTM output
	—	O2		Reserved
	—	O3		Reserved
	—	O4		Reserved
	—	O5		Reserved
	—	O6		Reserved
—	O7	Reserved		

**Package and Pinning Definitions TC277x Pin Definition and Functions:**
**Table 2-32 Port 32 Functions (cont'd)**

Pin	Symbol	Ctrl	Type	Function
<b>Y18</b>	P32.2	I	<b>LP / PU1 / VEXT</b>	General-purpose input
	TIN38			GTM input
	ARX3D			ASCLIN3 input
	RXDCAN3B			CAN node 3 input
	P32.2	O0		General-purpose output
	TOUT38	O1		GTM output
	ATX3	O2		ASCLIN3 output
	–	O3		Reserved
	–	O4		Reserved
	–	O5		Reserved
	DCDCSYNC	O6		SCU output
	–	O7		Reserved
<b>Y19</b>	P32.3	I	<b>LP / PU1 / VEXT</b>	General-purpose input
	TIN39			GTM input
	P32.3	O0		General-purpose output
	TOUT39	O1		GTM output
	ATX3	O2		ASCLIN3 output
	–	O3		Reserved
	ASCLK3	O4		ASCLIN3 output
	TXDCAN3	O5		CAN node 3 output
	–	O6		Reserved
	–	O7		Reserved
<b>W18</b>	P32.4	I	<b>MP+ / PU1 / VEXT</b>	General-purpose input
	TIN40			GTM input
	ACTS1B			ASCLIN1 input
	SDI12			MSC1 input
	P32.4	O0		General-purpose output
	TOUT40	O1		GTM output
	–	O2		Reserved
	END12	O3		MSC1 output
	GTMCLK1	O4		GTM output
	EN10	O5		MSC1 output
	EXTCLK1	O6		SCU output
	COUT63	O7		CCU60 output

## Package and Pinning Definitions TC277x Pin Definition and Functions:

Table 2-32 Port 32 Functions (cont'd)

Pin	Symbol	Ctrl	Type	Function
<b>T15</b>	P32.5	I	<b>LP / PU1 / VEXT</b>	General-purpose input
	TIN140			GTM input
	P32.5	O0		General-purpose output
	TOUT140	O1		GTM output
	ATX2	O2		ASCLIN2 output
	—	O3		Reserved
	—	O4		Reserved
	—	O5		Reserved
	TXDCAN2	O6		CAN node 2 output
	—	O7		Reserved
<b>U15</b>	P32.6	I	<b>LP / PU1 / VEXT</b>	General-purpose input
	TGI4			OCDS input
	TIN141			GTM input
	RXDCAN2C			CAN node 2 input
	ARX2F			ASCLIN2 input
	P32.6	O0		General-purpose output
	TOUT141	O1		GTM output
	—	O2		Reserved
	—	O3		Reserved
	SLSO212	O4		QSPI2 output
	—	O5		Reserved
	—	O6		Reserved
	—	O7		Reserved
	TGO4	HWOUT		OCDS; ENx
<b>U16</b>	P32.7	I	<b>LP / PU1 / VEXT</b>	General-purpose input
	TIN142			GTM input
	TGI5			OCDS input
	P32.7	O0		General-purpose output
	TOUT142	O1		GTM output
	—	O2		Reserved
	—	O3		Reserved
	—	O4		Reserved
	—	O5		Reserved
	—	O6		Reserved
	—	O7		Reserved
	TGO5	HWOUT		OCDS; ENx

## Package and Pinning Definitions TC277x Pin Definition and Functions:

Table 2-33 Port 33 Functions

Pin	Symbol	Ctrl	Type	Function
W10	P33.0	I	LP / PU1 / VEXT	General-purpose input
	TIN22			GTM input
	DSITR0E			DSADC channel 0 input E
	P33.0	O0		General-purpose output
	TOUT22	O1		GTM output
	–	O2		Reserved
	–	O3		Reserved
	–	O4		Reserved
	–	O5		Reserved
	VADCG2BFL0	O6		VADC output
	–	O7		Reserved
Y10	P33.1	I	LP / PU1 / VEXT	General-purpose input
	TIN23			GTM input
	PSIRX0C			PSI5 input
	SENT9C			SENT input
	DSCIN2B			DSADC channel 2 input B
	DSITR1E			DSADC channel 1 input E
	P33.1	O0		General-purpose output
	TOUT23	O1		GTM output
	ASLSO3	O2		ASCLIN3 output
	–	O3		Reserved
	DSCOUT2	O4		DSADC channel 2 output
	VADCEMUX02	O5		VADC output
	VADCG2BFL1	O6		VADC output
	–	O7		Reserved
W11	P33.2	I	LP / PU1 / VEXT	General-purpose input
	TIN24			GTM input
	SENT8C			SENT input
	DSDIN2B			DSADC channel 2 input B
	DSITR2E			DSADC channel 2 input E
	P33.2	O0		General-purpose output
	TOUT24	O1		GTM output
	ASCLK3	O2		ASCLIN3 output
	–	O3		Reserved
	PSITX0	O4		PSI5 output
	VADCEMUX01	O5		VADC output
	VADCG2BFL2	O6		VADC output
	–	O7		Reserved

## Package and Pinning Definitions TC277x Pin Definition and Functions:

Table 2-33 Port 33 Functions (cont'd)

Pin	Symbol	Ctrl	Type	Function
Y11	P33.3	I	LP / PU1 / VEXT	General-purpose input
	TIN25			GTM input
	PSIRX1C			PSI5 input
	SENT7C			SENT input
	DSCIN1B			DSADC channel 1 input B
	P33.3			O0
	TOUT25	O1		GTM output
	–	O2		Reserved
	–	O3		Reserved
	DSCOUT1	O4		DSADC channel 1 output
	VADCEMUX00	O5		VADC output
	VADCG2BFL3	O6		VADC output
	–	O7		Reserved
	W12	P33.4		I
TIN26		GTM input		
SENT6C		SENT input		
CTR $\overline$ APC		CCU61 input		
DSDIN1B		DSADC channel 1 input B		
DSITR0F		DSADC channel 0 input F		
P33.4		O0	General-purpose output	
TOUT26		O1	GTM output	
ARTS2		O2	ASCLIN2 output	
–		O3	Reserved	
PSITX1		O4	PSI5 output	
VADCEMUX12		O5	VADC output	
VADCG0BFL0		O6	VADC output	
–		O7	Reserved	

## Package and Pinning Definitions TC277x Pin Definition and Functions:

Table 2-33 Port 33 Functions (cont'd)

Pin	Symbol	Ctrl	Type	Function
Y12	P33.5	I	LP / PU1 / VEXT	General-purpose input
	TIN27			GTM input
	ACTS2B			ASCLIN2 input
	PSIRX2C			PSI5 input
	PSISRXC			PSI5-S input
	SENT5C			SENT input
	CCPOS2C			CCU61 input
	T4EADB			GPT120 input
	DSCIN0B			DSADC channel 0 input B
	DSITR1F			DSADC channel 1 input F
	P33.5			O0
	TOUT27	O1	GTM output	
	SLSO07	O2	QSPI0 output	
	SLSO17	O3	QSPI1 output	
	DSCOUT0	O4	DSADC channel 0 output	
	VADCEMUX11	O5	VADC output	
	VADCG0BFL1	O6	VADC output	
	-	O7	Reserved	
	W13	P33.6	I	LP / PU1 / VEXT
TIN28		GTM input		
SENT4C		SENT input		
CCPOS1C		CCU61 input		
T2EADB		GPT120 input		
DSDIN0B		DSADC channel 0 input B		
DSITR2F		DSADC channel 2 input F		
P33.6		O0	General-purpose output	
TOUT28		O1	GTM output	
ASLSO2		O2	ASCLIN2 output	
-		O3	Reserved	
PSITX2		O4	PSI5 output	
VADCEMUX10		O5	VADC output	
VADCG1BFL0		O6	VADC output	
PSISTX		O7	PSI5-S output	

## Package and Pinning Definitions TC277x Pin Definition and Functions:

Table 2-33 Port 33 Functions (cont'd)

Pin	Symbol	Ctrl	Type	Function
Y13	P33.7	I	LP / PU1 / VEXT	General-purpose input
	TIN29			GTM input
	RXDCAN0E			CAN node 0 input
	REQ8			SCU input
	CCPOS0C			CCU61 input
	T2INB			GPT120 input
	P33.7			O0
	TOUT29	O1		GTM output
	ASCLK2	O2		ASCLIN2 output
	SLSO37	O3		QSPI3 output
	–	O4		Reserved
	–	O5		Reserved
	VADCG1BFL1	O6		VADC output
	–	O7		Reserved
W14	P33.8	I	MP / HighZ/ VEXT	General-purpose input
	TIN30			GTM input
	ARX2E			ASCLIN2 input
	EMGSTOPA			SCU input
	P33.8	O0		General-purpose output
	TOUT30	O1		GTM output
	ATX2	O2		ASCLIN2 output
	SLSO32	O3		QSPI3 output
	–	O4		Reserved
	TXDCAN0	O5		CAN node 0 output
	–	O6		Reserved
	COUT62	O7		CCU61 output
	SMUFSP	HWOUT		SMU
Y14	P33.9	I	LP / PU1 / VEXT	General-purpose input
	TIN31			GTM input
	P33.9	O0		General-purpose output
	TOUT31	O1		GTM output
	ATX2	O2		ASCLIN2 output
	SLSO31	O3		QSPI3 output
	ASCLK2	O4		ASCLIN2 output
	–	O5		Reserved
	–	O6		Reserved
	CC62	O7		CCU61 output

## Package and Pinning Definitions TC277x Pin Definition and Functions:

Table 2-33 Port 33 Functions (cont'd)

Pin	Symbol	Ctrl	Type	Function
<b>W15</b>	P33.10	I	<b>MP / PU1 / VEXT</b>	General-purpose input
	TIN32			GTM input
	SLSI3C			QSPI3 input
	P33.10	O0		General-purpose output
	TOUT32	O1		GTM output
	SLSO16	O2		QSPI1 output
	SLSO311	O3		QSPI3 output
	ASLSO1	O4		ASCLIN1 output
	PSISCLK	O5		PSI5-S output
	–	O6		Reserved
COUT61	O7	CCU61 output		
<b>Y15</b>	P33.11	I	<b>MP / PU1 / VEXT</b>	General-purpose input
	TIN33			GTM input
	SCLK3D			QSPI3 input
	P33.11	O0		General-purpose output
	TOUT33	O1		GTM output
	ASCLK1	O2		ASCLIN1 output
	SCLK3	O3		QSPI3 output
	–	O4		Reserved
	–	O5		Reserved
	DSCGPWMN	O6		DSADC output
CC61	O7	CCU61 output		
<b>W16</b>	P33.12	I	<b>MP / PU1 / VEXT</b>	General-purpose input
	TIN34			GTM input
	MTSR3D			QSPI3 input
	P33.12	O0		General-purpose output
	TOUT34	O1		GTM output
	ATX1	O2		ASCLIN1 output
	MTSR3	O3		QSPI3 output
	ASCLK1	O4		ASCLIN1 output
	–	O5		Reserved
	DSCGPWMP	O6		DSADC output
COUT60	O7	CCU61 output		

## Package and Pinning Definitions TC277x Pin Definition and Functions:

Table 2-33 Port 33 Functions (cont'd)

Pin	Symbol	Ctrl	Type	Function
Y16	P33.13	I	MP / PU1 / VEXT	General-purpose input
	TIN35			GTM input
	ARX1F			ASCLIN1 input
	MRST3D			QSPI3 input
	DSSGNB			DSADC input
	INJ11			MSC1 input
	P33.13			O0
	TOUT35	O1		GTM output
	ATX1	O2		ASCLIN1 output
	MRST3	O3		QSPI3 output
	SLSO26	O4		QSPI2 output
	–	O5		Reserved
	DCDCSYNC	O6		SCU output
	CC60	O7		CCU61 output
T14	P33.14	I	LP / PU1 / VEXT	General-purpose input
	TIN143			GTM input
	$\overline{\text{TGI6}}$			OCDS input
	SCLK2D			QSPI2 input
	P33.14			O0
	TOUT143	O1		GTM output
	–	O2		Reserved
	SCLK2	O3		QSPI2 output
	–	O4		Reserved
	–	O5		Reserved
	–	O6		Reserved
	CC62	O7		CCU60 output
	$\overline{\text{TGO6}}$	HWOUT		OCDS; ENx

## Package and Pinning Definitions TC277x Pin Definition and Functions:

Table 2-33 Port 33 Functions (cont'd)

Pin	Symbol	Ctrl	Type	Function
U14	P33.15	I	LP / PU1 / VEXT	General-purpose input
	TIN144			GTM input
	TGI7			OCDS input
	P33.15	O0		General-purpose output
	TOUT144	O1		GTM output
	—	O2		Reserved
	SLSO211	O3		QSPI2 output
	—	O4		Reserved
	—	O5		Reserved
	—	O6		Reserved
	COU62	O7		CCU60 output
	TGO7	HWOUT		OCDS; ENx

Table 2-34 Port 34 Functions

Pin	Symbol	Ctrl	Type	Function
U11	P34.1	I	LP / PU1 / VEXT	General-purpose input
	TIN146			GTM input
	P34.1	O0		General-purpose output
	TOUT146	O1		GTM output
	ATX0	O2		ASCLIN0 output
	—	O3		Reserved
	TXDCAN0	O4		CAN node 0 output
	—	O5		Reserved
	—	O6		Reserved
COU63	O7	CCU60 output		
T12	P34.2	I	LP / PU1 / VEXT	General-purpose input
	TIN147			GTM input
	ARX0D			ASCLIN0 input
	RXDCAN0G			CAN node 0 input
	P34.2	O0		General-purpose output
	TOUT147	O1		GTM output
	—	O2		Reserved
	—	O3		Reserved
	—	O4		Reserved
	—	O5		Reserved
	—	O6		Reserved
	CC60	O7		CCU60 output

## Package and Pinning Definitions TC277x Pin Definition and Functions:

Table 2-34 Port 34 Functions (cont'd)

Pin	Symbol	Ctrl	Type	Function
<b>U12</b>	P34.3	I	<b>LP / PU1 / VEXT</b>	General-purpose input
	TIN148			GTM input
	P34.3			General-purpose output
	TOUT148	O0		GTM output
	—	O1		Reserved
	—	O2		Reserved
	—	O3		Reserved
	SLSO210	O4		QSPI2 output
	—	O5		Reserved
	—	O6		Reserved
COUT60	O7	CCU60 output		
<b>T13</b>	P34.4	I	<b>LP / PU1 / VEXT</b>	General-purpose input
	TIN149			GTM input
	MRST2D			QSPI2 input
	P34.4	O0		General-purpose output
	TOUT149	O1		GTM output
	—	O2		Reserved
	—	O3		Reserved
	MRST2	O4		QSPI2 output
	—	O5		Reserved
	—	O6		Reserved
CC61	O7	CCU60 output		
<b>U13</b>	P34.5	I	<b>LP / PU1 / VEXT</b>	General-purpose input
	TIN150			GTM input
	MTRSR2D			QSPI2 input
	P34.5	O0		General-purpose output
	TOUT150	O1		GTM output
	—	O2		Reserved
	—	O3		Reserved
	MTRSR2	O4		QSPI2 output
	—	O5		Reserved
	—	O6		Reserved
COUT61	O7	CCU60 output		

## Package and Pinning Definitions TC277x Pin Definition and Functions:

Table 2-35 Port 40 Functions

Pin	Symbol	Ctrl	Type	Function
W2	P40.0	I	S / HighZ / VDDM	General-purpose input
	VADCG3.0			VADC analog input channel 0 of group 3
	DS2PB			DSADC: positive analog input channel of DSADC 2, pin B
	CCPOS0D			CCU60 input
	SENT0A			SENT input
W1	P40.1	I	S / HighZ / VDDM	General-purpose input
	VADCG3.1			VADC analog input channel 1 of group 3 (MD)
	DS2NB			DSADC: negative analog input channel 2, pin B
	CCPOS1B			CCU60 input
	SENT1A			SENT input
V2	P40.2	I	S / HighZ / VDDM	General-purpose input
	VADCG3.2			VADC analog input channel 2 of group 3 (MD)
	CCPOS1D			CCU60 input
	SENT2A			SENT input
V1	P40.3	I	S / HighZ / VDDM	General-purpose input
	VADCG3.3			VADC analog input channel 3 of group 3 (with pull down diagnostics)
	CCPOS2B			CCU60 input
	SENT3A			SENT input
P4	P40.4	I	S / HighZ / VDDM	General-purpose input
	VADCG4.0			VADC analog input channel 0 of group 4
	CCPOS2D			CCU60 input
	SENT4A			SENT input
R1	P40.5	I	S / HighZ / VDDM	General-purpose input
	VADCG4.1			VADC analog input channel 1 of group 4 (MD)
	CCPOS0D			CCU61 input
	SENT5A			SENT input
N4	P40.6	I	S / HighZ / VDDM	General-purpose input
	VADCG4.4			VADC analog input channel 4 of group 4
	DS3PA			DSADC: positive analog input of channel 3, pin A
	CCPOS1B			CCU61 input
	SENT6A			SENT input
P2	P40.7	I	S / HighZ / VDDM	General-purpose input
	VADCG4.5			VADC analog input channel 5 of group 4
	DS3NA			DSADC: negative analog input of channel 3, pin A
	CCPOS1D			CCU61 input
	SENT7A			SENT input

**Package and Pinning Definitions TC277x Pin Definition and Functions:**
**Table 2-35 Port 40 Functions (cont'd)**

Pin	Symbol	Ctrl	Type	Function
<b>N5</b>	P40.8	I	<b>S / HighZ / VDDM</b>	General-purpose input
	VADCG4.6			VADC analog input channel 6 of group 4
	DS3PB			DSADC: positive analog input of channel 3, pin B
	CCPOS2B			CCU61 input
	SENT8A			SENT input
<b>P1</b>	P40.9	I	<b>S / HighZ / VDDM</b>	General-purpose input
	VADCG4.7			VADC analog input channel 7 of group 4
	DS3NB			DSADC: negative analog input of channel 3, pin B
	CCPOS2D			CCU61 input
	SENT9A			SENT input

**Table 2-36 Analog Inputs**

Pin	Symbol	Ctrl	Type	Function
<b>T10</b>	AN0	I	<b>D / HighZ / VDDM</b>	Analog input 0
	VADCG0.0			VADC analog input channel 0 of group 0
	DS1PA			DSADC: positive analog of input channel 1, pin A
<b>U10</b>	AN1	I	<b>D / HighZ / VDDM</b>	Analog input 1
	VADCG0.1			VADC analog input channel 1 of group 0 (MD)
	DS1NA			DSADC: negative analog input of channel 1, pin A
<b>W9</b>	AN2	I	<b>D / HighZ / VDDM</b>	Analog input 2
	VADCG0.2			VADC analog input channel 2 of group 0 (MD)
	DS0PA			DSADC: positive analog input of channel 0, pin A
<b>U9</b>	AN3	I	<b>D / HighZ / VDDM</b>	Analog input 3
	VADCG0.3			VADC analog input channel 3 of group 0
	DS0NA			DSADC: negative analog input of channel 0, pin A
<b>T9</b>	AN4	I	<b>D / HighZ / VDDM</b>	Analog input 4
	VADCG0.4			VADC analog input channel 4 of group 0
<b>Y9</b>	AN5	I	<b>D / HighZ / VDDM</b>	Analog input 5
	VADCG0.5			VADC analog input channel 5 of group 0
<b>T8</b>	AN6	I	<b>D / HighZ / VDDM</b>	Analog input 6
	VADCG0.6			VADC analog input channel 6 of group 0
<b>U8</b>	AN7	I	<b>D / HighZ / VDDM</b>	Analog input 7
	VADCG0.7			VADC analog input channel 7 of group 0 (with pull down diagnostics)
<b>W8</b>	AN8	I	<b>D / HighZ / VDDM</b>	Analog input 8
	VADCG1.0			VADC analog input channel 0 of group 1

**Package and Pinning Definitions TC277x Pin Definition and Functions:**
**Table 2-36 Analog Inputs (cont'd)**

Pin	Symbol	Ctrl	Type	Function
U7	AN9	I	D / HighZ / VDDM	Analog input 9
	VADCG1.1			VADC analog input channel 1 of group 1 (MD)
Y8	AN10	I	D / HighZ / VDDM	Analog input 10
	VADCG1.2			VADC analog input channel 2 of group 1 (MD)
W7	AN11	I	D / HighZ / VDDM	Analog input 11
	VADCG1.3			VADC analog input channel 3 of group 1 (with pull down diagnostics)
T7	AN12	I	D / HighZ / VDDM	Analog input 12
	VADCG1.4			VADC analog input channel 4 of group 1
W6	AN13	I	D / HighZ / VDDM	Analog input 13
	VADCG1.5			VADC analog input channel 5 of group 1
U6	AN14	I	D / HighZ / VDDM	Analog input 14
	VADCG1.6			VADC analog input channel 6 of group 1
T6	AN15	I	D / HighZ / VDDM	Analog input 15
	VADCG1.7			VADC analog input channel 7 of group 1
W5	AN16	I	D / HighZ / VDDM	Analog input 16
	VADCG2.0			VADC analog input channel 0 of group 2
U5	AN17	I	D / HighZ / VDDM	Analog input 17
	VADCG2.1			VADC analog input channel 1 of group 2 (MD)
W4	AN18	I	D / HighZ / VDDM	Analog input 18
	VADCG2.2			VADC analog input channel 2 of group 2 (MD)
W3	AN19	I	D / HighZ / VDDM	Analog input 19
	VADCG2.3			VADC analog input channel 3 of group 2 (with pull down diagnostics)
Y3	AN20	I	D / HighZ / VDDM	Analog input 20
	VADCG2.4	I		VADC analog input channel 4 of group 2
	DS2PA	I		DSADC: positive analog input of channel 2, pin A
Y2	AN21	I	D / HighZ / VDDM	Analog input 21
	VADCG2.5	I		VADC analog input channel 5 of group 2
	DS2NA	I		DSADC: negative analog input of channel of DSADC 2, pin A
T5	AN22	I	D / HighZ / VDDM	Analog input 22
	VADCG2.6			VADC analog input channel 6 of group 2

**Package and Pinning Definitions TC277x Pin Definition and Functions:**
**Table 2-36 Analog Inputs (cont'd)**

Pin	Symbol	Ctrl	Type	Function
<b>R5</b>	AN23	I	<b>D / HighZ / VDDM</b>	Analog input 23
	VADCG2.7			VADC analog input channel 7 of group 2
<b>W2</b>	AN24	I	<b>S / HighZ / VDDM</b>	Analog input 24
	VADCG3.0			VADC analog input channel 0 of group 3
	DS2PB			DSADC: positive analog input of channel 2, pin B
	SENT0A			SENT input channel 0, pin A
<b>W1</b>	AN25	I	<b>S / HighZ / VDDM</b>	Analog input 24
	VADCG3.1			VADC analog input channel 1 of group 3 (MD)
	DS2NB			DSADC: negative analog input of channel 2, pin B
	SENT1A			SENT input channel 1, pin A
<b>V2</b>	AN26	I	<b>S / HighZ / VDDM</b>	Analog input 26
	VADCG3.2			VADC analog input channel 2 of group 3 (MD)
	SENT2A			SENT input channel 2, pin A
<b>V1</b>	AN27	I	<b>S / HighZ / VDDM</b>	Analog input 27
	VADCG3.3			VADC analog input channel 3 of group 3 (with pull down diagnostics)
	SENT3A			SENT input channel 3, pin A
<b>U2</b>	AN28	I	<b>D / HighZ / VDDM</b>	Analog input 28
	VADCG3.4			VADC analog input channel 4 of group 3
<b>U1</b>	AN29	I	<b>D / HighZ / VDDM</b>	Analog input 29
	VADCG3.5			VADC analog input channel 5 of group 3
<b>T4</b>	AN30	I	<b>D / HighZ / VDDM</b>	Analog input 30
	VADCG3.6			VADC analog input channel 6 of group 3
<b>R4</b>	AN31	I	<b>D / HighZ / VDDM</b>	Analog input 31
	VADCG3.7			VADC analog input channel 7 of group 3
<b>P4</b>	AN32	I	<b>S / HighZ / VDDM</b>	Analog input 32
	VADCG4.0			VADC analog input channel 0 of group 4
	SENT4A			SENT input channel 4, pin A
<b>R1</b>	AN33	I	<b>S / HighZ / VDDM</b>	Analog input 33
	VADCG4.1			VADC analog input channel 1 of group 4 (MD)
	SENT5A			SENT input channel 5, pin A
<b>P5</b>	AN34	I	<b>D / HighZ / VDDM</b>	Analog input 34
	VADCG4.2			VADC analog input channel 2 of group 4 (MD)

**Package and Pinning Definitions TC277x Pin Definition and Functions:**
**Table 2-36 Analog Inputs (cont'd)**

Pin	Symbol	Ctrl	Type	Function
<b>R2</b>	AN35	I	<b>D / HighZ / VDDM</b>	Analog input 35
	VADCG4.3			VADC analog input channel 3 of group 4 (with pull down diagnostics)
<b>N4</b>	AN36	I	<b>S / HighZ / VDDM</b>	Analog input 34
	VADCG4.4			VADC analog input channel 4 of group 4
	DS3PA			DSADC: positive analog input of channel of DSADC 3, pin A
	SENT6A			SENT input channel 6, pin A
<b>P2</b>	AN37	I	<b>S / HighZ / VDDM</b>	Analog input 37
	VADCG4.5			VADC analog input channel 5 of group 4
	DS3NA			DSADC: negative analog input of channel of DSADC 3, pin A
	SENT7A			SENT input channel 7, pin A
<b>N5</b>	AN38	I	<b>S / HighZ / VDDM</b>	Analog input 38
	VADCG4.6			VADC analog input channel 6 of group 4
	DS3PB			DSADC: positive analog input of channel of DSADC 3, pin B
	SENT8A			SENT input channel 8, pin A
<b>P1</b>	AN39	I	<b>S / HighZ / VDDM</b>	Analog input 39
	VADCG4.7			VADC analog input channel 7 of group 4
	DS3NB			DSADC: negative analog input of channel of DSADC 3, pin B
	SENT9A			SENT input channel 9, pin A
<b>M5</b>	AN40	I	<b>D / HighZ / VDDM</b>	Analog input 40
	VADCG5.0			VADC analog input channel 0 of group 5
<b>M4</b>	AN41	I	<b>D / HighZ / VDDM</b>	Analog input 41
	VADCG5.1			VADC analog input channel 1 of group 5 (MD)
<b>L5</b>	AN42	I	<b>D / HighZ / VDDM</b>	Analog input 42
	VADCG5.2			VADC analog input channel 2 of group 5 (MD)
<b>L4</b>	AN43	I	<b>D / HighZ / VDDM</b>	Analog input 43
	VADCG5.3			VADC analog input channel 3 of group 5 (with pull down diagnostics)
<b>N1</b>	AN44	I	<b>D / HighZ / VDDM</b>	Analog input 44
	VADCG5.4			VADC analog input channel 4 of group 5
	DS3PC			DSADC: positive analog input of channel of DSADC 3, pin C

**Package and Pinning Definitions TC277x Pin Definition and Functions:**
**Table 2-36 Analog Inputs (cont'd)**

Pin	Symbol	Ctrl	Type	Function
<b>N2</b>	AN45	I	<b>D / HighZ / VDDM</b>	Analog input 45
	VADCG5.5			VADC analog input channel 5 of group 5
	DS3NC			DSADC: negative analog input of channel of DSADC 3, pin C
<b>M1</b>	AN46	I	<b>D / HighZ / VDDM</b>	Analog input 46
	VADCG5.6			VADC analog input channel 6 of group 5
	DS3PD			DSADC: positive analog input of channel of DSADC 3, pin D
<b>M2</b>	AN47	I	<b>D / HighZ / VDDM</b>	Analog input 47
	VADCG5.7			VADC analog input channel 7 of group 5
	DS3ND			DSADC: negative analog input of channel of DSADC 3, pin D

**Table 2-37 System I/O**

Pin	Symbol	Ctrl	Type	Function
<b>G17</b>	$\overline{\text{PORST}}$	I	<b>I / PD / VEXT</b>	Power On Reset Input Additional strong PD in case of power fail.
<b>F16</b>	$\overline{\text{ESR0}}$	I/O	<b>MP / OD / VEXT</b>	External System Request Reset 0 Default configuration during and after reset is open-drain driver. The driver drives low during power-on reset. This is valid additionally after deactivation of $\overline{\text{PORST}}$ until the internal reset phase has finished. See also SCU chapter for details. Default after power-on can be different. See also SCU chapter 'Reset Control Unit' and SCU_IOCRR register description.
	EVRWUP	I		EVR Wakeup Pin
<b>G16</b>	$\overline{\text{ESR1}}$	I/O	<b>MP / PU1 / VEXT</b>	External System Request Reset 1 Default NMI function. See also SCU chapter 'Reset Control Unit' and SCU_IOCRR register description.
	EVRWUP	I		EVR Wakeup Pin
<b>W17</b>	VGATE1P	O	<b>VGATE1P / - / VEXT</b>	External Pass Device gate control for EVR13
<b>K16</b>	TMS	I	<b>A2 / PD / VDDP3</b>	JTAG Module State Machine Control Input
	DAP1	I/O		Device Access Port Line 1
<b>L19</b>	$\overline{\text{TRST}}$	I	<b>A2 / PD / VDDP3</b>	JTAG Module Reset/Enable Input

**Package and Pinning Definitions TC277x Pin Definition and Functions:**
**Table 2-37 System I/O (cont'd)**

Pin	Symbol	Ctrl	Type	Function
<b>J16</b>	TCK	I	<b>A2 /</b>	JTAG Module Clock Input
	DAP0	I	<b>PD /</b> <b>VDDP3</b>	Device Access Port Line 0
<b>M20</b>	XTAL1	I	<b>XTAL1 /</b> <b>- /</b> <b>VDDP3</b>	Main Oscillator/PLL/Clock Generator Input
<b>M19</b>	XTAL2	O	<b>XTAL2 /</b> <b>- /</b> <b>VDDP3</b>	Main Oscillator/PLL/Clock Generator Output

**Table 2-38 Supply**

Pin	Symbol	Ctrl	Type	Function
<b>Y6</b>	VAREF1	I	<b>Vx</b>	Positive Analog Reference Voltage 1
<b>Y7</b>	VAGND1	I	<b>Vx</b>	Negative Analog Reference Voltage 1
<b>T1</b>	VAREF2	I	<b>Vx</b>	Positive Analog Reference Voltage 2
<b>T2</b>	VAGND2	I	<b>Vx</b>	Negative Analog Reference Voltage 2
<b>Y5</b>	VDDM	I	<b>Vx</b>	ADC Analog Power Supply (3.3V / 5V)
<b>G8, H7</b>	VDD / VDDSB	I	<b>Vx</b>	Emulation Device: Emulation SRAM Standby Power Supply (1.3V) (Emulation Device only). Production Device: VDD (1.3V).
<b>P8, P13, N7, N14, H14, G13</b>	VDD	I	<b>Vx</b>	Digital Core Power Supply (1.3V)
<b>N19</b>	VDD	I	<b>Vx</b>	Digital Core Power Supply (1.3V). The supply pin inturn supplies the main XTAL Oscillator/PLL (1.3V) . A higher decoupling capacitor is therefore recommended to the VSS pin for better noise immunity.
<b>A2, B3, V19, W20</b>	VEXT	I	<b>Vx</b>	External Power Supply (5V / 3.3V)
<b>B18, A19</b>	VDDP3	I	<b>Vx</b>	Digital Power Supply for Flash (3.3V). Can be also used as external 3.3V Power Supply for VFLEX.
<b>N20</b>	VDDP3	I	<b>Vx</b>	Digital Power Supply for Oscillator, LVDSH and A2 pads (3.3V). The supply pin inturn supplies the main XTAL Oscillator/PLL (3.3V) . A higher decoupling capacitor is therefore recommended to the VSS pin for better noise immunity.

**Package and Pinning Definitions TC277x Pin Definition and Functions:**
**Table 2-38 Supply (cont'd)**

Pin	Symbol	Ctrl	Type	Function
<b>E15, D16</b>	VDDFL3	I	<b>Vx</b>	Flash Power Supply (3.3V)
<b>D5</b>	VFLEX	I	<b>Vx</b>	Digital Power Supply for Flex Port Pads (5V / 3.3V)
<b>Y4</b>	VSSM	I	<b>Vx</b>	Analog Ground for VDDM
<b>T11</b>	VEVRSB	I	<b>Vx</b>	Standby Power Supply (3.3V/5V) for the Standby SRAM (CPU0.DSPR). If Standby mode is not used: To be handled like VEXT (3.3V/5V).
<b>B2, D4, E5, L20, T16, U17, W19, Y20</b>	VSS	I	<b>Vx</b>	Digital Ground
<b>E16, D17, B19, A20</b>	VSS	I	<b>Vx</b>	Digital Ground (outer balls)
<b>P9, P12, N9, N10, N11, N12</b>	VSS	I	<b>Vx</b>	Digital Ground (center balls)
<b>M7, M8, M10, M11, M13, M14</b>	VSS	I	<b>Vx</b>	Digital Ground (center balls)
<b>L8, L9, L10, L11, L12, L13</b>	VSS	I	<b>Vx</b>	Digital Ground (center balls)
<b>K8, K9, K10, K11, K12, K13</b>	VSS	I	<b>Vx</b>	Digital Ground (center balls)
<b>J7, J8, J10, J11, J13, J14</b>	VSS	I	<b>Vx</b>	Digital Ground (center balls)
<b>H9, H10, H11, H12, G9, G10, G11, G12</b>	VSS	I	<b>Vx</b>	Digital Ground (center balls)
<b>P10</b>	VSS	I	<b>Vx</b>	Digital Ground (center balls) This ball is used in the Emulation Device as AGBT TX0N
<b>P11</b>	VSS	I	<b>Vx</b>	Digital Ground (center balls) This ball is used in the Emulation Device as AGBT TX0P
<b>L7</b>	VSS	I	<b>Vx</b>	Digital Ground (center balls) This ball is used in the Emulation Device as AGBT CLKN

**Package and Pinning Definitions TC277x Pin Definition and Functions:**
**Table 2-38 Supply (cont'd)**

Pin	Symbol	Ctrl	Type	Function
<b>K7</b>	VSS	I	<b>Vx</b>	Digital Ground (center balls) This ball is used in the Emulation Device as AGBT CLKP
<b>L14</b>	VSS	I	<b>Vx</b>	Digital Ground (center balls) This ball is used in the Emulation Device as AGBT ERR
<b>K14</b>	NC / VDDPSB	I	<b>NCVDDP SB</b>	Emulation Device: Power Supply (3.3V) for DAP/JTAG pad group. Can be connected to VDDP or can be left unsupplied (see document 'AurixED' / Aurix Emulation Devices specification).  Production Device: This pin is not connected on package level. It can be connected on PCB level to VDDP or Ground or can be left unsupplied.
<b>A1, Y1, U4</b>	NC	I	<b>NC</b>	Not Connected. These pins are not connected on package level and will not be used for future extensions.

**Legend:**

Column "Ctrl.":

 I = Input (for GPIO port Lines with IOCR bit field Selection PCx = 0XXX<sub>B</sub>)

O = Output

 O0 = Output with IOCR bit field selection PCx = 1X000<sub>B</sub>

 O1 = Output with IOCR bit field selection PCx = 1X001<sub>B</sub> (ALT1)

 O2 = Output with IOCR bit field selection PCx = 1X010<sub>B</sub> (ALT2)

 O3 = Output with IOCR bit field selection PCx = 1X011<sub>B</sub> (ALT3)

 O4 = Output with IOCR bit field selection PCx = 1X100<sub>B</sub> (ALT4)

 O5 = Output with IOCR bit field selection PCx = 1X101<sub>B</sub> (ALT5)

 O6 = Output with IOCR bit field selection PCx = 1X110<sub>B</sub> (ALT6)

 O7 = Output with IOCR bit field selection PCx = 1X111<sub>B</sub> (ALT7)

Column "Type":

LP = Pad class LP (5V/3.3V, LVTTTL)

MP = Pad class MP (5V/3.3V, LVTTTL)

MP+ = Pad class MP+ (5V/3.3V, LVTTTL)

MPR = Pad class MPR (5V/3.3V, LVTTTL)

A2 = Pad class A2 (3.3V, LVTTTL)

LVDSM = Pad class LVDSM (LVDS/CMOS 5V/3.3V)

LVDSH = Pad class LVDSH (LVDS/CMOS 3.3V)

S = Pad class S (ADC overlaid with General Purpose Input)

D = Pad class D (ADC)

 PU = with pull-up device connected during reset ( $\overline{\text{PORST}} = 0$ )

 PU1 = with pull-up device connected during reset ( $\overline{\text{PORST}} = 0$ )<sup>1) 2) 3)</sup>

1) The default state of GPIOs (Px.y) during and after  $\overline{\text{PORST}}$  active is controlled via HWCFG[6] (P14.4). HWCFG[6] has a weak internal pull-up active at start-up if the pin is left unconnected. See also User's Manual, "Introduction Chapter", "General Purpose I/O Ports and Peripheral I/O Lines", Figure: "Default state of port pins during and after reset".

---

**Package and Pinning Definitions TC277x Pin Definition and Functions:**

PD = with pull-down device connected during reset ( $\overline{\text{PORST}} = 0$ )

PD1 = with pull-down device connected during reset ( $\overline{\text{PORST}} = 0$ )<sup>1) 2) 3)</sup>

PX = Behavior depends on usage: PD in EVR13 SMPS Mode and PU1 in GPIO Mode

OD = open drain during reset ( $\overline{\text{PORST}} = 0$ )

HighZ = tri-state during reset ( $\overline{\text{PORST}} = 0$ )

PORST =  $\overline{\text{PORST}}$  input pad

XTAL1 = XTAL1 input pad

XTAL2 = XTAL2 input pad

VGATE1P = VGATE1P

VGATE3P = VGATE3P

Vx = Supply

NC = These pins are reserved for future extensions and shall not be connected externally

NC1 = These pins are not connected on package level and will not be used for future extensions

NCVDDPSB = This pin has a different functionality in an Production Device and an Emulation Device. For details pls. see Pin/Ball description of this pin.

NCVDDSB = This pin has a different functionality in an Production Device and an Emulation Device. For details pls. see Pin/Ball description of this pin.

## 2.2.2 Emergency Stop Function

The Emergency Stop function can be used to force GPIOs (General Purpose Inputs/Outputs) via an external input signal (EMGSTOPA or EMGSTOPB) into a defined state:

- Input state and
- PU or High-Z depending on HWCFG[6] level latched during  $\overline{\text{PORST}}$  active

Control of the Emergency Stop function:

- The Emergency Stop function can be enabled/disabled in the SCU (see chapter "SCU", "Emergency Stop Control")
- The Emergency Stop input signal, EMGSTOPA (P33.8) / EMGSTOPB (P21.2), can selected in the SCU (see chapter "SCU", "Emergency Stop Control")
- On port level, each GPIO can be enabled/disabled for the Emergency Stop function via the Px\_ESR (Port x Emergency Stop) registers in the port control logic (see chapter "General Purpose I/O Ports and Peripheral I/O Lines", "Emergency Stop Register").

The Emergency Stop function is available for all GPIO Ports with the following exceptions:

- Not available for P20.2 (General Purpose Input/GPI only, overlaid with Testmode)
- Not available for P40.x (analog input ANx overlaid with GPI)
- Not available for P32.0 EVR13 SMPS mode.
- Not available for dedicated I/O without General Purpose Output function (e.g ESRx, TMS, TCK)

The Emergency Stop function can be overruled on the following GPIO Ports:

- P00.x: Emergency Stop can be overruled by the VADC. Overruling can be disabled via the control register P00\_SCR (see chapter "General Purpose I/O Ports and Peripheral I/O Lines", P00)
- P14.0 and P14.1: Emergency Stop can be overruled in the DXCPL mode (DAP over can physical layer mode). No Overruling in the DXCM (Debug over can message) mode
- P21.6: Emergency Stop can be overruled in JTAG mode if this pin is used as TDI
- P21.7: Emergency Stop can be overruled in JTAG or Three Pin DAP mode

2) If HWCFG[6] is left unconnected or is externally pulled high, weak internal pull-ups (PU1) / pull-downs (PD1) are active during and after reset.

3) If HWCFG[6] is connected to ground, the PD1 / PU1 pins are predominantly in HighZ during and after reset.

## Package and Pinning Definitions TC277x Pin Definition and Functions:

- P20.0: Emergency Stop can be overruled in JTAG mode if this GPIO is used as TDI

### 2.2.3 Pull-Up/Pull-Down Reset Behavior of the Pins

**Table 2-39 List of Pull-Up/Pull-Down Reset Behavior of the Pins**

Pins	$\overline{\text{PORST}} = 0$	$\overline{\text{PORST}} = 1$
all GPIOs	Pull-up if HWCFG[6] = 1 or High-Z if HWCFG[6] = 0	
$\overline{\text{TDI}}$ , $\overline{\text{TESTMODE}}$	Pull-up	
$\overline{\text{PORST}}^{1)}$	Pull-down with $I_{\text{PORST}}$ relevant	Pull-down with $I_{\text{PDLI}}$ relevant
$\overline{\text{TRST}}$ , TCK, TMS	Pull-down	
ESR0	The open-drain driver is used to drive low. <sup>2)</sup>	Pull-up <sup>3)</sup>
ESR1	Pull-up <sup>3)</sup>	
TDO	Pull-up	High-Z/Pull-up <sup>4)</sup>

1) Pull-down with  $I_{\text{PORST}}$  relevant is always activated when a primary supply monitor detects a violation.

2) Valid additionally after deactivation of  $\overline{\text{PORST}}$  until the internal reset phase has finished. See the SCU chapter for details.

3) See the SCU\_IOCRR register description.

4) Depends on JTAG/DAP selection with  $\overline{\text{TRST}}$ .

In case of leakage test ( $\overline{\text{PORST}} = 0$  and  $\overline{\text{TESTMODE}} = 0$ ), the pull-down of the  $\overline{\text{TRST}}$  pin is switched off. In case of an user application ( $\overline{\text{TESTMODE}} = 1$ ), the pull-down of the  $\overline{\text{TRST}}$  is always switched on.

## 2.3 TC270x Bare Die Pad Definition

The TC270x Bare Die Logic Symbol is shown in [Figure 2-3](#).

[Table 2-40](#) describes the pads of the TC270x Bare Die. It describes also the mapping of VADC / DS-ADC channels to the analog inputs (ANx) and the mapping of Port functions to the pads.

*Note: The detailed description of the port functions (Px.y) can be found in the User's Manual chapter "General Purpose I/O Ports and Peripheral I/O Lines (Ports)".*

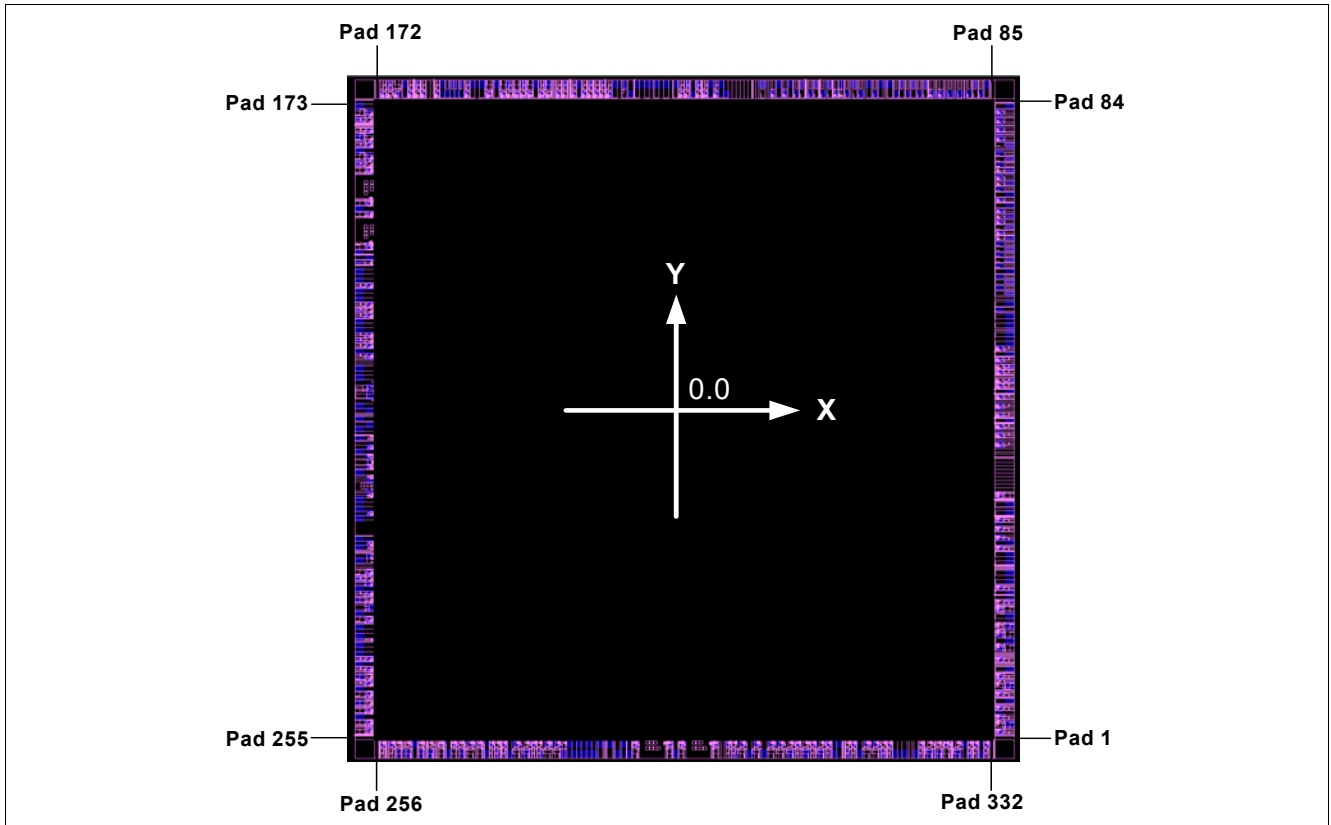

Figure 2-3 TC270x Logic Symbol for the Bare Die.

Table 2-40 List of the TC270x Bare Die Pads

Number	Pad Name	Pad Type	X	Y	Comment
1	P10.8	LP / PU1 / VEXT	3265500	-3460000	GPIO
2	P02.0	MP+ / PU1 / VEXT	3374000	-3380000	GPIO
3	P02.9	LP / PU1 / VEXT	3265500	-3300000	GPIO
4	P02.1	LP / PU1 / VEXT	3265500	-3200000	GPIO
5	VSS	Vx	3374000	-3125000	Must be bonded to VSS
6	P02.10	LP / PU1 / VEXT	3265500	-3050000	GPIO
7	P02.2	MP+ / PU1 / VEXT	3374000	-2950000	GPIO
8	P02.11	LP / PU1 / VEXT	3265500	-2850000	GPIO
9	VEXT	Vx	3374000	-2775000	Must be bonded to VEXT
10	P02.3	LP / PU1 / VEXT	3265500	-2670000	GPIO

**Package and Pinning Definitions TC270x Bare Die Pad Definition**
**Table 2-40 List of the TC270x Bare Die Pads**

Number	Pad Name	Pad Type	X	Y	Comment
11	P02.4	MP+ / PU1 / VEXT	3265500	-2540000	GPIO
12	VSS	Vx	3374000	-2465000	Must be bonded to VSS
13	P02.5	MP+ / PU1 / VEXT	3265500	-2390000	GPIO
14	P02.6	MP / PU1 / VEXT	3374000	-2300000	GPIO
15	VEXT	Vx	3374000	-2195000	Must be bonded to VEXT
16	P02.7	MP / PU1 / VEXT	3265500	-2110000	GPIO
17	P02.8	LP / PU1 / VEXT	3374000	-2040000	GPIO
18	VSS	Vx	3374000	-1940000	Must be bonded to VSS
19	P01.3	LP / PU1 / VEXT	3265500	-1883500	GPIO
20	VDD	Vx	3374000	-1818500	Must be bonded to VDD
21	VSS	Vx	3374000	-1688500	Must be bonded to VSS
22	VSS	Vx	3374000	-1644500	Must be bonded to VSS. Double Pad (Elephant Pad), shared with Pad Nr 22.
23	VDD	Vx	3374000	-1514500	Must be bonded to VSS. Double Pad (Elephant Pad), shared with Pad Nr 21.
24	P01.4	LP / PU1 / VEXT	3265500	-1449500	GPIO
25	VSS	Vx	3374000	-1394500	Must be bonded to VSS
26	P01.5	LP / PU1 / VEXT	3265500	-1339500	GPIO
27	P01.6	LP / PU1 / VEXT	3265500	-1239500	GPIO
28	P01.7	LP / PU1 / VEXT	3265500	-1139500	GPIO
29	VEXT	Vx	3374000	-1068500	Must be bonded to VEXT
30	VSS	Vx	3374000	-968500	Must be bonded to VSS
31	P00.0	MP / PU1 / VEXT	3265500	-868500	GPIO
32	P00.1	LP / PU1 / VEXT	3265500	-241000	GPIO
33	P00.2	LP / PU1 / VEXT	3265500	-141000	GPIO
34	P00.3	LP / PU1 / VEXT	3265500	-41000	GPIO
35	VSS	Vx	3374000	19000	Must be bonded to VSS
36	P00.4	LP / PU1 / VEXT	3265500	79000	GPIO
37	P00.5	LP / PU1 / VEXT	3265500	179000	GPIO
38	P00.6	LP / PU1 / VEXT	3265500	279000	GPIO
39	VEXT	Vx	3374000	339000	Must be bonded to VEXT
40	P00.7	LP / PU1 / VEXT	3265500	399000	GPIO
41	P00.8	LP / PU1 / VEXT	3374000	459000	GPIO
42	P00.9	LP / PU1 / VEXT	3265500	549000	GPIO

**Package and Pinning Definitions TC270x Bare Die Pad Definition**
**Table 2-40 List of the TC270x Bare Die Pads**

Number	Pad Name	Pad Type	X	Y	Comment
43	P00.10	LP / PU1 / VEXT	3374000	609000	GPIO
44	P00.11	LP / PU1 / VEXT	3265500	689000	GPIO
45	VSS	Vx	3374000	749000	Must be bonded to VSS
46	P00.12	LP / PU1 / VEXT	3265500	809000	GPIO
47	VDD	Vx	3374000	864000	Must be bonded to VDD
48	VSS	Vx	3374000	964000	Must be bonded to VSS
49	VSS	Vx	3374000	1064000	Must be bonded to VSS
50	VDD	Vx	3374000	1164000	Must be bonded to VDD
51	VEXT	Vx	3265500	1239000	Must be bonded to VEXT
52	VSS	Vx	3374000	1299000	Must be bonded to VSS
53	VAREF3	Vx	3374000	1419000	Positive Analog Reference Voltage 3
54	VAREF2	Vx	3265500	1479000	Positive Analog Reference Voltage 2
55	VAGND3	Vx	3374000	1539000	Negative Analog Reference Voltage 3
56	VAGND2	Vx	3265500	1599000	Negative Analog Reference Voltage 2
57	VDDM	Vx	3374000	1659000	Must be bonded to VEXT
58	AN47 (VADC5.7 / DS3ND)	D	3265500	1719000	Analog input
59	AN46 (VADC5.6 / DS3PD)	D	3374000	1779000	Analog input
60	AN45 (VADC5.5 / DS3NC)	D	3265500	1839000	Analog input
61	AN44 (VADC5.4 / DS3PC)	D	3374000	1899000	Analog input
62	AN43 (VADC5.3)	D	3265500	1959000	Analog input (with pull down diagnostics)
63	AN42 (VADC5.2)	D	3374000	2019000	Analog input
64	AN41 (VADC5.1)	D	3265500	2079000	Analog input
65	AN40 (VADC5.0)	D	3374000	2139000	Analog input
66	AN39 (VADC4.7 / DS3NB), P40.9 (SENT9A)	S	3265500	2199000	Analog input, GPI (SENT)
67	AN38 (VADC4.6 / DS3PB), P40.8 (SENT8A)	S	3374000	2259000	Analog input, GPI (SENT)
68	AN37 (VADC4.5 / DS3NA), P40.7 (SENT7A)	S	3265500	2319000	Analog input, GPI (SENT)

**Package and Pinning Definitions TC270x Bare Die Pad Definition**
**Table 2-40 List of the TC270x Bare Die Pads**

Number	Pad Name	Pad Type	X	Y	Comment
69	VDDM	Vx	3374000	2379000	Must be bonded to VEXT
70	AN36 (VADC4.4 / DS3PA), P40.6 ( SENT6A)	S	3265500	2439000	Analog input, GPI (SENT)
71	VSSM	Vx	3374000	2499000	Must be bonded to VSS
72	AN35 (VADC4.3)	D	3265500	2559000	Analog input (with pull down diagnostics)
73	AN34 (VADC4.2)	D	3374000	2619000	Analog input
74	AN33 (VADC4.1), P40.5 ( SENT5A)	S	3265500	2679000	Analog input, GPI (SENT)
75	AN32 (VADC4.0), P40.4 ( SENT4A)	S	3374000	2765000	Analog input, GPI (SENT)
76	AN31 (VADC3.7)	D	3265500	2825000	Analog input
77	AN30 (VADC3.6)	D	3374000	2885000	Analog input
78	AN29 (VADC3.5)	D	3265500	2945000	Analog input
79	AN28 (VADC3.4)	D	3374000	3045000	GPIO
80	AN27 (VADC3.3), P40.3 ( SENT3A)	S	3265500	3105000	Analog input (with pull down diagnostics), GPI (SENT)
81	AN26 (VADC3.2), P40.2 ( SENT2A)	S	3265500	3205000	Analog input, GPI (SENT)
82	AN25 (VADC3.1 / DS2NB), P40.1 ( SENT1A)	S	3265500	3305000	Analog input, GPI (SENT)
83	AN24 (VADC3.0 / DS2PB), P40.0 ( SENT0A)	S	3265500	3405000	Analog input, GPI (SENT)
84	VDDM	Vx	3374000	3465000	Must be bonded to VEXT
85	VSSM	Vx	3134000	3705000	Must be bonded to VSS
86	AN23 (VADC2.7)	D	3074000	3596500	Analog input
87	AN22 (VADC2.6)	D	3014000	3705000	Analog input
88	AN21 (VADC2.5 / DS2NA)	D	2954000	3596500	Analog input
89	AN20 (VADC2.4 / DS2PA)	D	2854000	3596500	Analog input
90	AN19 (VADC2.3)	D	2754000	3596500	Analog input (with pull down diagnostics)
91	AN18 (VADC2.2)	D	2654000	3596500	Analog input
92	AN17 (VADC2.1)	D	2554000	3596500	Analog input

**Package and Pinning Definitions TC270x Bare Die Pad Definition**
**Table 2-40 List of the TC270x Bare Die Pads**

Number	Pad Name	Pad Type	X	Y	Comment
93	AN16 (VADC2.0)	D	2494000	3705000	Analog input
94	AN15 (VADC1.7)	D	2434000	3596500	Analog input
95	VAGND1	Vx	2374000	3705000	Negative Analog Reference Voltage 1
96	VAGND0	Vx	2314000	3596500	Negative Analog Reference Voltage 0
97	VAREF1	Vx	2254000	3705000	Positive Analog Reference Voltage 1
98	VAREF0	Vx	2194000	3596500	Positive Analog Reference Voltage 0
99	VSSM	Vx	2134000	3705000	Must be bonded to VSS
100	VSSM	Vx	2074000	3596500	Must be bonded to VSS
101	VSSMREF	Vx	2014000	3705000	Must be bonded to VSS
102	AN14 (VADC1.6)	D	1954000	3596500	Analog input
103	VDDM	Vx	1894000	3705000	Must be bonded to VEXT
104	VDDM	Vx	1829000	3596500	Must be bonded to VEXT
105	AN13 (VADC1.5)	D	1724000	3596500	Analog input
106	AN12 (VADC1.4)	D	1664000	3705000	Analog input
107	AN11 (VADC1.3)	D	1604000	3596500	Analog input (with pull down diagnostics)
108	AN10 (VADC1.2)	D	1544000	3705000	Analog input
109	AN9 (VADC1.1)	D	1484000	3569500	Analog input
110	AN8 (VADC1.0)	D	1424000	3705000	Analog input
111	AN7 (VADC0.7)	D	1364000	3596500	Analog input (with pull down diagnostics)
112	AN6 (VADC0.6)	D	1304000	3705000	Analog input
113	AN5 (VADC0.5)	D	1244000	3596500	Analog input
114	AN4 (VADC0.4)	D	1184000	3705000	Analog input
115	AN3 (VADC0.3 / DS0NA)	D	1124000	3596500	Analog input
116	VSSM	Vx	1064000	3705000	Must be bonded to VSS
117	AN2 (VADC0.2 / DS0PA)	D	1004000	3596500	Analog input
118	VDDM	Vx	944000	3705000	Must be bonded to VEXT
119	AN1 (VADC0.1 / DS1NA)	D	884000	3596500	Analog input
120	AN0 (VADC0.0 / DS1PA)	D	807000	3705000	Analog input
121	VEXT	Vx	427000	3596500	Must be bonded to VEXT
122	VSS	Vx	377000	3705000	Must be bonded to VSS

**Package and Pinning Definitions TC270x Bare Die Pad Definition**
**Table 2-40 List of the TC270x Bare Die Pads**

Number	Pad Name	Pad Type	X	Y	Comment
123	P34.1	LP / PU1 / VEXT	322000	3596500	GPIO
124	VSS	Vx	267000	3705000	Must be bonded to VSS
125	P34.2	LP / PU1 / VEXT	212000	3596500	GPIO
126	P34.3	LP / PU1 / VEXT	142000	3705000	GPIO
127	VEXT	Vx	87000	3596500	Must be bonded to VEXT
128	P34.4	LP / PU1 / VEXT	22000	3705000	GPIO
129	P34.5	LP / PU1 / VEXT	-38000	3596500	GPIO
130	VSS	Vx	-93000	3705000	Must be bonded to VSS
131	VDD	Vx	-193000	3705000	Must be bonded to VDD
132	VSS	Vx	-323000	3705000	Must be bonded to VSS. Double Pad (Elephant Pad), shared with Pad Nr 131.
133	VSS	Vx	-363000	3705000	Must be bonded to VSS. Double Pad (Elephant Pad), shared with Pad Nr 130.
134	VDD	Vx	-493000	3705000	Must be bonded to VDD
135	VEVRSB	Vx	-560000	3596500	Must be bonded to VEXT
136	EVR_OFF	Vx	-625000	3705000	Must be bonded to VSS+F178
137	VEXT	Vx	-725000	3705000	Must be bonded to VEXT
138	P33.0	LP / PU1 / VEXT	-790000	3596500	GPIO
139	P33.1	LP / PU1 / VEXT	-855000	3705000	GPIO
140	P33.2	LP / PU1 / VEXT	-915000	3596500	GPIO
141	P33.3	LP / PU1 / VEXT	-985000	3705000	GPIO
142	P33.4	LP / PU1 / VEXT	-1045000	3596500	GPIO
143	VSS	Vx	-1100000	3705000	Must be bonded to VSS
144	P33.5	LP / PU1 / VEXT	-1155000	3596500	GPIO
145	P33.6	LP / PU1 / VEXT	-1250000	3705000	GPIO
146	P33.7	LP / PU1 / VEXT	-1310000	3596500	GPIO
147	P33.8	MP / HighZ / VEXT	-1420000	3705000	GPIO
148	P33.9	LP / PU1 / VEXT	-1490000	3596500	GPIO
149	VEXT	Vx	-1545000	3705000	Must be bonded to VEXT
150	P33.10	MP / PU1 / VEXT	-1610000	3596500	GPIO
151	P33.14	LP / PU1 / VEXT	-1680000	3705000	GPIO
152	P33.11	MP / PU1 / VEXT	-1750000	3596500	GPIO
153	P33.15	LP / PU1 / VEXT	-1820000	3705000	GPIO
154	P33.12	MP / PU1 / VEXT	-1890000	3596500	GPIO

**Package and Pinning Definitions TC270x Bare Die Pad Definition**
**Table 2-40 List of the TC270x Bare Die Pads**

Number	Pad Name	Pad Type	X	Y	Comment
155	VSS	Vx	-1955000	3705000	Must be bonded to VSS
156	P33.13	MP / PU1 / VEXT	-2040000	3596500	GPIO
157	VSS	Vx	-2105000	3705000	Must be bonded to VSS
158	VDD	Vx	-2205000	3705000	Must be bonded to VDD
159	P32.0	LP / EVR13 SMPS -> PD, GPIO -> PU1 / VEXT	-2260000	3596500	GPIO
160	VGATE1N (SMPS)	VGATE1N	-2315000	3705000	Must be bonded to VSS if EVR13 SMPS is not used. Must be bonded to NMOS gate if EVR13 SMPS used.
161	VGATE1P (SMPS)	VGATE1P	-2365000	3596500	Must be bonded to VEXT if EVR13 SMPS is not used. Must be bonded to PMOS gate if EVR13 SMPS used.
162	VGATE3P (LDO)	VGATE3P	-2415000	3705000	Must be bonded to VSS
163	VGATE1P (LDO)	VGATE1P	-2465000	3596500	Must be bonded to VSS if no external P channel MOSFET used for EVR13 LDO generation. Must be bonded to external P channel MOSFET if external LDO pass device used.
164	VEXT	Vx	-2515000	3705000	Must be bonded to VEXT
165	P32.2	LP / PU1 / VEXT	-2570000	3596500	GPIO
166	P32.3	LP / PU1 / VEXT	-2714000	3596500	GPIO
167	P32.6	LP / PU1 / VEXT	-2774000	3705000	GPIO
168	P32.5	LP / PU1 / VEXT	-2849000	3596500	GPIO
169	VSS	Vx	-2904000	3705000	Must be bonded to VSS
170	P32.4	MP+ / PU1 / VEXT	-2989000	3596500	GPIO
171	P32.7	LP / PU1 / VEXT	-3069000	3705000	GPIO
172	P23.0	LP / PU1 / VEXT	-3129000	3596500	GPIO
173	VSS	Vx	-3374000	3391000	Must be bonded to VSS
174	P23.1	MP+ / PU1 / VEXT	-3265500	3316000	GPIO
175	P23.2	LP / PU1 / VEXT	-3374000	3236000	GPIO
176	P23.3	LP / PU1 / VEXT	-3265500	3125000	GPIO
177	P23.4	MP+ / PU1 / VEXT	-3374000	3045000	GPIO

**Package and Pinning Definitions TC270x Bare Die Pad Definition**
**Table 2-40 List of the TC270x Bare Die Pads**

Number	Pad Name	Pad Type	X	Y	Comment
178	P23.6	LP / PU1 / VEXT	-3265500	2965000	GPIO
179	VEXT	Vx	-3374000	2910000	Must be bonded to VEXT
180	P23.5	MP+ / PU1 / VEXT	-3265500	2835000	GPIO
181	P23.7	LP / PU1 / VEXT	-3374000	2755000	GPIO
182	P22.0	MP / LVDSM_N / PU1 / VEXT	-3265500	2685000	GPIO
183	P22.1	MP / LVDS_P / PU1 / VEXT	-3265500	2335000	GPIO
184	VSS	Vx	-3374000	2270000	Must be bonded to VSS
185	P22.2	MP / LVDSM_N / PU1 / VEXT	-3265500	2205000	GPIO
186	P22.3	MP / LVDS_P / PU1 / VEXT	-3265500	1855000	GPIO
187	VEXT	Vx	-3374000	1790000	Must be bonded to VEXT
188	VEXT	Vx	-3265500	1735000	Must be bonded to VEXT
189	Reserved	Vx	-3374000	1680000	Must be bonded to VSS
190	VDD	Vx	-3374000	1580000	Must be bonded to VDD
191	VSS	Vx	-3374000	1480000	Must be bonded to VSS
192	P22.4	LP / PU1 / VEXT	-3265500	1425000	GPIO
193	VSS	Vx	-3374000	1370000	Must be bonded to VSS
194	VDD	Vx	-3374000	1270000	Must be bonded to VDD
195	P22.5	LP / PU1 / VEXT	-3265500	1215000	GPIO
196	P22.6	LP / PU1 / VEXT	-3374000	1155000	GPIO
197	P22.7	LP / PU1 / VEXT	-3265500	1095000	GPIO
198	VSS	Vx	-3374000	1040000	Must be bonded to VSS
199	VDD	Vx	-3374000	940000	Must be bonded to VDD
200	P22.8	LP / PU1 / VEXT	-3265500	885000	GPIO
201	P22.9	LP / PU1 / VEXT	-3374000	825000	GPIO
202	P22.10	LP / PU1 / VEXT	-3265500	765000	GPIO
203	VSS	Vx	-3374000	710000	Must be bonded to VSS
204	P22.11	LP / PU1 / VEXT	-3265500	655000	GPIO
205	VDDOSC	Vx	-3374000	520000	Must be bonded to VDD
206	VSSOSC	Vx	-3374000	420000	Must be bonded to VSS
207	XTAL1	XTAL1	-3265500	312500	Main Oscillator/PLL/Clock Generator Input. Must be bonded to external quartz or resonator

**Package and Pinning Definitions TC270x Bare Die Pad Definition**
**Table 2-40 List of the TC270x Bare Die Pads**

Number	Pad Name	Pad Type	X	Y	Comment
208	XTAL2	XTAL2	-3265500	212500	Main Oscillator/PLL/Clock Generator Input. Must be bonded to external quartz or resonator
209	VSSOSC3	Vx	-3374000	105000	Must be bonded to VSS
210	VDDOSC3	Vx	-3265500	55000	Must be bonded to VDDP3
211	VDDP3	Vx	-3374000	-35000	Must be bonded to VDDP3
212	VDDP3	Vx	-3265500	-95000	Must be bonded to VDDP3
213	VSS	Vx	-3374000	-145000	Must be bonded to VSS
214	P21.0	A2 / PU1 / VDDP3	-3374000	-245000	GPIO
215	P21.1	A2 / PU1 / VDDP3	-3265500	-345000	GPIO
216	VSS	Vx	-3374000	-395000	Must be bonded to VSS
217	P21.2	LVDSH_N / PU1 / VDDP3	-3265500	-457500	GPIO
218	P21.3	LVDSH_P / PU1 / VDDP3	-3265500	-557500	GPIO
219	VDDP3	Vx	-3374000	-620000	Must be bonded to VDDP3
220	P21.4	LVDSH_N / PU1 / VDDP3	-3265500	-694500	GPIO
221	P21.5	LVDSH_P / PU1 / VDDP3	-3265500	-845500	GPIO
222	VDD	Vx	-3374000	-920000	Must be bonded to VDD
223	VSS	Vx	-3374000	-1020000	Must be bonded to VSS
224	P21.6	A2 / PU / VDDP3	-3265500	-1070000	GPIO, TDI
225	VDDP3	Vx	-3374000	-1120000	Must be bonded to VDDP3
226	VSS	Vx	-3374000	-1345000	Must be bonded to VSS
227	TMS / DAP1	A2 / PD / VDDP3	-3265500	-1395000	JTAG Module State Machine Control Input / Device Access Port Line 1
228	P21.7	A2 / PU / VDDP3	-3374000	-1445000	GPIO, TDO
229	TRST (N)	A2 / PU / VDDP3	-3265500	-1535000	JTAG Module Reset/Enable Input
230	TCK / DAP0	A2 / PU / VDDP3	-3374000	-1585000	JTAG Module Clock Input / Device Access Port Line 0
231	P20.0	MP / PU1 / VEXT	-3265500	-1720000	GPIO
232	P20.1	LP / PU1 / VEXT	-3374000	-1790000	GPIO
233	P20.2	LP / PU / VEXT	-3265500	-1845000	Testmode pin must be bonded
234	VSS	Vx	-3374000	-1895000	Must be bonded to VSS

**Package and Pinning Definitions TC270x Bare Die Pad Definition**
**Table 2-40 List of the TC270x Bare Die Pads**

Number	Pad Name	Pad Type	X	Y	Comment
235	P20.3	LP / PU1 / VEXT	-3265500	-1950000	GPIO
236	ESR1 (N) / EVRWUP	MP / PU1 / VEXT	-3374000	-2020000	External System Request Reset 1. Default NMI function. EVR Wakeup Pin.
237	PORST (N)	I / PD1 / VEXT	-3265500	-2102500	Power On Reset Input. Additional strong PD in case of power fail.
238	VEXT	Vx	-3374000	-2170000	Must be bonded to VEXT
239	ESR0 (N) / EVRWUP	MP / OD	-3265500	-2235000	External System Request Reset 0. Default configuration during and after reset is open-drain driver. The driver drives low during power-on reset. EVR Wakeup Pin.
240	VDD	Vx	-3374000	-2310000	Must be bonded to VDD
241	VSS	Vx	-3374000	-2440000	Must be bonded to VSS. Double Pad (Elephant Pad), shared with Pad Nr 240.
242	VSS	Vx	-3374000	-2480000	Must be bonded to VSS. Double Pad (Elephant Pad), shared with Pad Nr 239.
243	VDD	Vx	-3374000	-2610000	Must be bonded to VDD
244	P20.6	LP / PU1 / VEXT	-3265500	-2665000	GPIO
245	VSS	Vx	-3374000	-2720000	Must be bonded to VSS
246	P20.7	LP / PU1 / VEXT	-3265500	-2775000	GPIO
247	P20.8	MP / PU1 / VEXT	-3374000	-2865000	GPIO
248	P20.9	LP / PU1 / VEXT	-3265500	-2935000	GPIO
249	VEXT	Vx	-3374000	-2990000	Must be bonded to VEXT
250	P20.10	MP / PU1 / VEXT	-3265500	-3055000	GPIO
251	P20.11	MP / PU1 / VEXT	-3374000	-3155000	GPIO
252	P20.12	MP / PU1 / VEXT	-3265500	-3235000	GPIO
253	VSS	Vx	-3374000	-3300000	Must be bonded to VSS
254	P20.13	MP / PU1 / VEXT	-3265500	-3365000	GPIO
255	P20.14	MP / PU1 / VEXT	-3265500	-3465000	GPIO
256	P15.0	LP / PU1 / VEXT	-3134000	-3596500	GPIO
257	P15.1	LP / PU1 / VEXT	-3034000	-3596500	GPIO
258	P15.2	MP / PU1 / VEXT	-2964000	-3705000	GPIO
259	P15.3	MP / PU1 / VEXT	-2864000	-3705000	GPIO
260	VEXT	Vx	-2799000	-3596500	Must be bonded to VEXT

**Package and Pinning Definitions TC270x Bare Die Pad Definition**
**Table 2-40 List of the TC270x Bare Die Pads**

Number	Pad Name	Pad Type	X	Y	Comment
261	P15.4	MP / PU1 / VEXT	-2734000	-3705000	GPIO
262	P15.5	MP / PU1 / VEXT	-2634000	-3705000	GPIO
263	P15.6	MP / PU1 / VEXT	-2522000	-3596500	GPIO
264	VSS	Vx	-2457000	-3705000	Must be bonded to VSS
265	P15.7	MP / PU1 / VEXT	-2392000	-3596500	GPIO
266	P15.8	MP / PU1 / VEXT	-2312000	-3705000	GPIO
267	P14.0	MP+ / PU1 / VEXT	-2222000	-3596500	GPIO
268	P14.1	MP / PU1 / VEXT	-2122000	-3596500	GPIO
269	VEXT	Vx	-2057000	-3705000	Must be bonded to VEXT
270	P14.2	LP / PU1 / VEXT	-2002000	-3596500	Must be bonded to VEXT if EVR13 active. Must be bonded to VSS if EVR13 inactive.
271	P14.3	LP / PU1 / VEXT	-1942000	-3705000	GPIO
272	P14.4	LP / PU1 / VEXT	-1872000	-3596500	GPIO
273	VSS	Vx	-1817000	-3705000	Must be bonded to VSS
274	P14.5	MP+ / PU1 / VEXT	-1742000	-3596500	GPIO
275	P14.6	MP+ / PU1 / VEXT	-1642000	-3705000	GPIO
276	P14.7	LP / PU1 / VEXT	-1562000	-3596500	GPIO
277	P14.8	LP / PU1 / VEXT	-1502000	-3705000	GPIO
278	P14.9	MP+ / PU1 / VEXT	-1422000	-3596500	GPIO
279	P14.10	MP+ / PU1 / VEXT	-1322000	-3596500	GPIO
280	Reserved	Vx	-1247000	-3705000	Must be bonded to VSS
281	VEXT	Vx	-1197000	-3596500	Must be bonded to VEXT
282	VSS	Vx	-1147000	-3705000	Must be bonded to VSS
283	VEXT	Vx	-1097000	-3596500	Must be bonded to VEXT
284	VSS	Vx	-1017000	-3705000	Must be bonded to VSS. Double Pad (Elephant Pad), shared with Pad Nr 284.
285	VDDP3	Vx	-994500	-3596500	Must be bonded to VDDP3
286	VSS	Vx	-972000	-3705000	Must be bonded to VSS. Double Pad (Elephant Pad), shared with Pad Nr 282.
287	VDDP3	Vx	-877000	-3596500	Must be bonded to VDDP3

**Package and Pinning Definitions TC270x Bare Die Pad Definition**
**Table 2-40 List of the TC270x Bare Die Pads**

Number	Pad Name	Pad Type	X	Y	Comment
288	VDDFL3	Vx	-777000	-3596500	Must be bonded to VDDP3
289	VDDFL3	Vx	-697000	-3705000	Must be bonded to VDDP3
290	VDDFL3	Vx	-629500	-3596500	Must be bonded to VDDP3
291	VSS	Vx	-577000	-3705000	Must be bonded to VSS
292	P13.0	MP / LVDSM_N / PU1 / VEXT	-512000	-3596500	GPIO
293	P13.1	MP / LVDS_P / PU1 / VEXT	-162000	-3596500	GPIO
294	VEXT	Vx	-97000	-3705000	Must be bonded to VEXT
295	P13.2	MP / LVDSM_N / PU1 / VEXT	-32000	-3596500	GPIO
296	P13.3	MP / LVDS_P / PU1 / VEXT	318000	-3596500	GPIO
297	P12.0	LP / PU1 / VFLEX	458000	-3596500	GPIO
298	P12.1	LP / PU1 / VFLEX	518000	-3705000	GPIO
299	P11.0	MP+ / PU1 / VFLEX	598000	-3596500	GPIO
300	VSSFLEX	Vx	673000	-3705000	Must be bonded to VSS
301	P11.1	MP+ / PU1 / VFLEX	748000	-3596500	GPIO
302	VFLEX	Vx	823000	-3705000	Must be bonded to VEXT or VDDP3
303	P11.2	MPR / PU1 / VFLEX	898000	-3596500	GPIO
304	P11.3	MPR / PU1 / VFLEX	998000	-3596500	GPIO
305	P11.4	MP+ / PU1 / VFLEX	1098000	-3705000	GPIO
306	P11.5	LP / PU1 / VFLEX	1178000	-3596500	GPIO
307	P11.6	MPR / PU1 / VFLEX	1258000	-3705000	GPIO
308	P11.7	LP / PU1 / VFLEX	1338000	-3596500	GPIO
309	P11.9	MP+ / PU1 / VFLEX	1418000	-3705000	GPIO
310	P11.8	LP / PU1 / VFLEX	1498000	-3596500	GPIO
311	VSSFLEX	Vx	1553000	-3705000	Must be bonded to VSS

**Package and Pinning Definitions TC270x Bare Die Pad Definition**
**Table 2-40 List of the TC270x Bare Die Pads**

Number	Pad Name	Pad Type	X	Y	Comment
312	VFLEX	Vx	1603000	-3596500	Must be bonded to VEXT or VDDP3
313	P11.10	LP / PU1 / VFLEX	1698000	-3705000	GPIO
314	P11.13	LP / PU1 / VFLEX	1758000	-3596500	GPIO
315	VSSFLEX	Vx	1813000	-3705000	Must be bonded to VSS
316	P11.11	MP+ / PU1 / VFLEX	1888000	-3596500	GPIO
317	P11.12	MPR / PU1 / VFLEX	1988000	-3596500	GPIO
318	P11.14	LP / PU1 / VFLEX	2068000	-3705000	GPIO
319	P11.15	LP / PU1 / VFLEX	2128000	-3596500	GPIO
320	VDD	Vx	2183000	-3705000	Must be bonded to VDD
321	VSS	Vx	2283000	-3705000	Must be bonded to VSS
322	VSS	Vx	2403000	-3705000	Must be bonded to VSS
323	P10.0	LP / PU1 / VEXT	2458000	-3596500	GPIO
324	P10.1	MP+ / PU1 / VEXT	2543000	-3705000	GPIO
325	P10.2	MP / PU1 / VEXT	2643000	-3705000	GPIO
326	P10.3	MP / PU1 / VEXT	2723000	-3596500	GPIO
327	P10.4	MP+ / PU1 / VEXT	2834000	-3705000	GPIO
328	VEXT	Vx	2909000	-3596500	Must be bonded to VEXT
329	P10.5	LP / PU1 / VEXT	2964000	-3705000	GPIO
330	P10.6	LP / PU1 / VEXT	3024000	-3596500	GPIO
331	VSS	Vx	3079000	-3705000	Must be bonded to VSS
332	P10.7	LP / PU1 / VEXT	3134000	-3596500	GPIO

**Legend:**

Column "**Number**":

Running number of pads in the pad frame

Column "**Name**":

Symbolic name of the pad.

The functions mapped on GPIO pads "Px.y" are described in the User's Manual chapter "General Purpose I/O Ports and Peripheral I/O Lines (Ports)"

Column "**Type**":

LP = Pad class LP (5V/3.3V, LVTTTL)

MP = Pad class MP (5V/3.3V, LVTTTL)

MP+ = Pad class MP+ (5V/3.3V, LVTTTL)

MPR = Pad class MPR (5V/3.3V, LVTTTL)  
 A2 = Pad class A2 (3.3V, LVTTTL)  
 LVDSM = Pad class LVDSM (LVDS/CMOS 5V/3.3V)  
 LVDSH = Pad class LVDSH (LVDS/CMOS 3.3V)  
 S = Pad class S (ADC overlaid with General Purpose Input)  
 D = Pad class D (ADC)  
 PU = with pull-up device connected during reset ( $\overline{\text{PORST}} = 0$ )  
 PU1 = with pull-up device connected during reset ( $\overline{\text{PORST}} = 0$ )<sup>1) 2) 3)</sup>  
 PD = with pull-down device connected during reset ( $\overline{\text{PORST}} = 0$ )  
 PD1 = with pull-down device connected during reset ( $\overline{\text{PORST}} = 0$ )<sup>1) 2) 3)</sup>  
 PX = Behavior depends on usage: PD in EVR13 SMPS Mode and PU1 in GPIO Mode  
 OD = open drain during reset ( $\overline{\text{PORST}} = 0$ )  
 HighZ = tri-state during reset ( $\text{PORST} = 0$ )  
 $\overline{\text{PORST}}$  =  $\overline{\text{PORST}}$  input pad  
 XTAL1 = XTAL1 input pad  
 XTAL2 = XTAL2 input pad  
 VGATE1P = VGATE1P  
 VGATE3P = VGATE3P  
 Vx = Supply  
 NC = These pins are reserved for future extensions and shall not be connected externally  
 NC1 = These pins are not connected on package level and will not be used for future extensions  
 NCVDDPSB = This pin has a different functionality in an Production Device and an Emulation Device. For details pls. see Pin/Ball description of this pin.  
 NCVDDSB = This pin has a different functionality in an Production Device and an Emulation Device. For details pls. see Pin/Ball description of this pin.  
 Column "X" / "Y":  
 Pad opening center coordinates (in nm)

### 2.3.1 Pad Openings

Two different pad openings are used:

- Standard Pad Opening is 70um x 75um where 70um is the width of the opening (width as seen from the die side) and 75um is the depth of the opening (from the die side into the silicon).
- Double Pad or Elephant Pad Opening is 130um x 75um where 130um is the width of the opening (width as seen from the die side) and 75um is the depth of the opening (from the die side into the silicon). The Double Pad openings are represented with two opening coordinates and two pad numbers. Double Pads are used only for supply and can be identified by the words 'Double Pad' or 'Elephant Pad' in the Comment column.

### 2.3.2 Emergency Stop Function

The Emergency Stop function can be used to force GPIOs (General Purpose Inputs/Outputs) via an external input signal (EMGSTOPA or EMGSTOPB) into a defined state:

1) The default state of GPIOs (Px.y) during and after  $\overline{\text{PORST}}$  active is controlled via HWCFG[6] (P14.4). HWCFG[6] has a weak internal pull-up active at start-up if the pin is left unconnected. See also User's Manual, "Introduction Chapter", "General Purpose I/O Ports and Peripheral I/O Lines", Figure: "Default state of port pins during and after reset".

2) If HWCFG[6] is left unconnected or is externally pulled high, weak internal pull-ups are active at GPIOs (Px.y) pins during and after reset. Exceptions are P33.8 (HighZ), P40.x (default configuration during and after reset: analog inputs, port input function disabled), ESR0, P21.6 / P21.7 (port pins overlaid with JTAG functionality).

3) If HWCFG[6] is connected to ground, port pins are predominantly in HighZ during and after reset. Exceptions are P33.8 (HighZ), P40.x (default configuration during and after reset: analog inputs, port input function disabled), ESR0, P21.6 / P21.7 (port pins overlaid with JTAG functionality).

**Package and Pinning Definitions TC270x Bare Die Pad Definition**

- Input state and
- PU or HighZ depending on HWCFG[6] level latched during  $\overline{\text{PORST}}$  active

Control of the Emergency Stop function:

- The Emergency Stop function can be enabled/disabled in the SCU (see chapter “SCU”, “Emergency Stop Control”)
- The Emergency Stop input signal, EMGSTOPA (P33.8) / EMGSTOPB (P21.2), can be selected in the SCU (see chapter “SCU”, “Emergency Stop Control”)
- On port level, each GPIO can be enabled/disabled for the Emergency Stop function via the Px\_ESR (Port x Emergency Stop) registers in the port control logic (see chapter “General Purpose I/O Ports and Peripheral I/O Lines”, “Emergency Stop Register”).

The Emergency Stop function is available for all GPIO Ports with the following exceptions:

- Not available for P20.2 (General Purpose Input/GPI only, overlaid with Testmode)
- Not available for P40.x (analog input ANx overlaid with GPI)
- Not available for P32.0 EVR13 SMPS mode.
- Not available for dedicated I/O without General Purpose Output function (e.g ESRx, TMS, TCK)

The Emergency Stop function can be overruled on the following GPIO Ports:

- P00.x: Emergency Stop can be overruled by the VADC. Overruling can be disabled via the control register P00\_SCR (see chapter “General Purpose I/O Ports and Peripheral I/O Lines”, P00)
- P14.0 and P14.1: Emergency Stop can be overruled in the DXCPL mode (DAP over can physical layer mode). No Overruling in the DXCM (Debug over can message) mode
- P21.6: Emergency Stop can be overruled in JTAG mode if this pin is used as TDI
- P21.7: Emergency Stop can be overruled in JTAG or Three Pin DAP mode
- P20.0: Emergency Stop can be overruled in JTAG mode if this GPIO is used as TDI

### 2.3.3 Pull-Up/Pull-Down Reset Behavior of the Pins

**Table 2-41 List of Pull-Up/Pull-Down Reset Behavior of the Pins**

Pins	$\overline{\text{PORST}} = 0$	$\overline{\text{PORST}} = 1$
all GPIOs	Pull-up if HWCFG[6] = 1 or High-Z if HWCFG[6] = 0	
$\overline{\text{TDI}}$ , $\overline{\text{TESTMODE}}$	Pull-up	
$\overline{\text{PORST}}^{1)}$	Pull-down with $I_{\text{PORST}}$ relevant	Pull-down with $I_{\text{PDLI}}$ relevant
$\overline{\text{TRST}}$ , TCK, TMS	Pull-down	
$\overline{\text{ESR0}}$	The open-drain driver is used to drive low. <sup>2)</sup>	Pull-up <sup>3)</sup>
$\overline{\text{ESR1}}$	Pull-up <sup>3)</sup>	
TDO	Pull-up	High-Z/Pull-up <sup>4)</sup>

1) Pull-down with  $I_{\text{PORST}}$  relevant is always activated when a primary supply monitor detects a violation.

2) Valid additionally after deactivation of  $\overline{\text{PORST}}$  until the internal reset phase has finished. See the SCU chapter for details.

3) See the SCU\_IOCRR register description.

4) Depends on JTAG/DAP selection with  $\overline{\text{TRST}}$ .

- In case of leakage test ( $\overline{\text{PORST}} = 0$  and  $\overline{\text{TESTMODE}} = 0$ ), the pull-down of the  $\overline{\text{TRST}}$  pin is switched off. In case of an user application ( $\overline{\text{TESTMODE}} = 1$ ), the pull-down of the  $\overline{\text{TRST}}$  is always switched on.

## 3 Electrical Specification

### 3.1 Parameter Interpretation

The parameters listed in this section partly represent the characteristics of the TC270 / TC275 / TC277 and partly its requirements on the system. To aid interpreting the parameters easily when evaluating them for a design, they are marked with an two-letter abbreviation in column "Symbol":

- **CC**  
Such parameters indicate **C**ontroller **C**haracteristics which are a distinctive feature of the TC270 / TC275 / TC277 and must be regarded for a system design.
- **SR**  
Such parameters indicate **S**ystem **R**equirements which must provided by the microcontroller system in which the TC270 / TC275 / TC277 designed in.

### 3.2 Absolute Maximum Ratings

Stresses above the values listed under “Absolute Maximum Ratings” may cause permanent damage to the device. This is a stress rating only and functional operation of the device at these or any other conditions above those indicated in the Operational Conditions of this specification is not implied. Exposure to absolute maximum rating conditions may affect device reliability.

**Table 3-1 Absolute Maximum Ratings**

Parameter	Symbol	Values			Unit	Note / Test Condition
		Min.	Typ.	Max.		
Storage Temperature	$T_{ST}$ SR	-65	-	170	°C	upto 65h @ $T_J = 150^\circ\text{C}$ ; upto 15h @ $T_J = 170^\circ\text{C}$
Voltage at $V_{DD}$ power supply pins with respect to $V_{SS}$ <sup>1)</sup>	$V_{DD}$ SR	-	-	1.9	V	
Voltage at $V_{DDP3}$ and $V_{DDFL3}$ power supply pins with respect to $V_{SS}$ <sup>1)</sup>	$V_{DDP3}$ SR	-	-	4.43	V	
Voltage at $V_{DDM}$ , $V_{EXT}$ and $V_{FLEX}$ power supply pins with respect to $V_{SS}$ <sup>1)</sup>	$V_{DDM}$ SR	-	-	7.0	V	
Voltage on any class A2 and LVDSH input pin with respect to $V_{SS}$ <sup>1)2)</sup>	$V_{IN}$ SR	-0.5	-	$\min(V_{DDP3} + 0.6, 4.23)$	V	Whatever is lower
Voltage on all other input pins with respect to $V_{SS}$ <sup>1)2)</sup>	$V_{IN}$ SR	-0.5	-	7.0	V	
Input current on any pin during overload condition <sup>3)</sup>	$I_{IN}$ SR	-10	-	10	mA	
Absolute maximum sum of all input circuit currents during overload condition <sup>3)</sup>	$\Sigma I_{IN}$ SR	-100	-	100	mA	

- 1) Valid for cumulated for up to 2.8h and pulse forms following a power supply switch on phase, where the rise and fall times are related to the system capacities and coils.
- 2) Voltages below  $V_{INmin}$  have no impact to the device reliability as long as the times and currents defined in section Pin Reliability in Overload for the affected pad(s) are not violated.
- 3) This parameter is an Absolute Maximum Rating. Exposure to Absolute Maximum Ratings for extended periods of time may damage the device.

### 3.3 Pin Reliability in Overload

When receiving signals from higher voltage devices, low-voltage devices experience overload currents and voltages that go beyond their own IO power supplies specification.

The following table defines overload conditions that will not cause any negative reliability impact if all the following conditions are met:

- full operation life-time is not exceeded
- **Operating Conditions** are met for
  - pad supply levels
  - temperature

If a pin current is out of the **Operating Conditions** but within the overload parameters, then the parameters functionality of this pin as stated in the Operating Conditions can no longer be guaranteed. Operation is still possible in most cases but with relaxed parameters.

*Note: An overload condition on one or more pins does not require a reset.*

**Table 3-2 Overload Parameters**

Parameter	Symbol	Values			Unit	Note / Test Condition
		Min.	Typ.	Max.		
Input current on any digital pin during overload condition	$I_{IN}$	-5	-	5	mA	except LVDS pins
		-15 <sup>1)</sup>	-	15 <sup>1)</sup>	mA	except LVDS pins; limited to max. 20 pulses with 1ms pulse length
Input current on LVDS pin during overload condition	$I_{INLVDS}$	-3	-	3	mA	
Absolute maximum sum of all input circuit currents during overload condition	$I_{ING}$	-50	-	50	mA	
Input current on analog input pin during overload condition	$I_{INANA}$	-3	-	3	mA	
		-5	-	5	mA	limited to 60h over lifetime
Absolute sum of all ADC inputs during overload condition	$I_{INSCA}$	-20	-	20	mA	
Absolute maximum sum of all input circuit currents during overload condition	$\Sigma I_{INS}$	-100	-	100	mA	
Signal voltage over/undershoot at GPIOs	$V_{OUS}$	$V_{SS} - 2$	-	$V_{EXT/FLEX} + 2$	V	limited to 60h over lifetime; Valid for LP, MP, MP+, and MPR pads
Inactive device pin current during overload condtion <sup>2)</sup>	$I_{ID}$	-1	-	1	mA	All power supply voltages $V_{DDx} = 0$
Sum of all inactive device pin currents <sup>2)</sup>	$I_{IDS}$	-100	-	100	mA	

## Electrical Specification Pin Reliability in Overload

Table 3-2 Overload Parameters (cont'd)

Parameter	Symbol	Values			Unit	Note / Test Condition
		Min.	Typ.	Max.		
Overload coupling factor for digital inputs, negative <sup>3)</sup>	$K_{\text{OVDN CC}}$	-	$2 \cdot 10^{-4}$	$6 \cdot 10^{-4}$		Overload injected on GPIO non LVDS pad and affecting neighbor LP and A2 pads; $-2\text{mA} < I_{\text{IN}} < 0\text{mA}$
		-	-	$1 \cdot 10^{-2}$		Overload injected on GPIO non LVDS pad and affecting neighbor LP and A2 pads; $-5\text{mA} < I_{\text{IN}} < -2\text{mA}$
		-	-	$1.7 \cdot 10^{-3}$		Overload injected on GPIO non LVDS pad and affecting neighbor MP, MP+, and MPR pads; $-2\text{mA} < I_{\text{IN}} < 0\text{mA}$
		-	-	$2 \cdot 10^{-2}$		Overload injected on GPIO non LVDS pad and affecting neighbor MP, MP+, and MPR pads; $-5\text{mA} < I_{\text{IN}} < -2\text{mA}$
		-	-	0.3		Overload injected on LVDS pad and affecting neighbor LVDS pads
		-	-	0.93		coupling between pads 21.2 and 21.3
Overload coupling factor for digital inputs, positive <sup>3)</sup>	$K_{\text{OVDP CC}}$	-	-	$1 \cdot 10^{-5}$		Overload injected on GPIO non LVDS pad and affecting neighbor GPIO non LVDS pads
		-	-	$1 \cdot 10^{-4}$		Overload injected on GPIO pad and affecting neighbor P32.0 pad
		-	-	$5 \cdot 10^{-4}$		Overload injected on LVDS pad and affecting neighbor LVDS pads

**Electrical Specification Pin Reliability in Overload**
**Table 3-2 Overload Parameters (cont'd)**

Parameter	Symbol	Values			Unit	Note / Test Condition
		Min.	Typ.	Max.		
Overload coupling factor for analog inputs, negative	$K_{OVAN}$ CC	-	-	$6 \cdot 10^{-4}$ 4)		Analog Inputs overlaid with class LP pads or pull down diagnostics; $-1\text{mA} < I_{IN} < 0\text{mA}$
		-	-	$1 \cdot 10^{-2}$		Analog Inputs overlaid with class LP pads or pull down diagnostics; $-5\text{mA} < I_{IN} < -1\text{mA}$
		-	-	$1 \cdot 10^{-4}$		else; $-5\text{mA} < I_{IN} < 0\text{mA}$
Overload coupling factor for analog inputs, positive	$K_{OVAP}$ CC	-	-	$1 \cdot 10^{-5}$		$5\text{mA} < I_{IN} < 0\text{mA}$

- 1) Reduced VADC / DSADC result accuracy and / or GPIO input levels ( $V_{IL}$  and  $V_{IH}$ ) can differ from specified parameters.
- 2) Limitations for time and supply levels specified in this section are not valid for this parameter.
- 3) Overload is measured as increase of pad leakage caused by injection on neighbor pad.
- 4) For analogue inputs overlaid with DSADC function the VCM holdbuffer shall be enabled, in case DSADCs are enabled.

Note: DSADC input pins count as analog pins as they are overlaid with VADC pins.

**Table 3-3 PN-Junction Characteristics for positive Overload**

Pad Type	$I_{IN} = 3 \text{ mA}$	$I_{IN} = 5 \text{ mA}$
F / A2	$U_{IN} = V_{DDP3} + 0.5 \text{ V}$	$U_{IN} = V_{DDP3} + 0.6 \text{ V}$
LP / MP / MP+ / MPR	$U_{IN} = V_{EXT/FLEX} + 0.75 \text{ V}$	$U_{IN} = V_{EXT/FLEX} + 0.8 \text{ V}$
LVDSM	$U_{IN} = V_{EXT} + 0.75 \text{ V}$	-
LVDSH	$U_{IN} = V_{DDP3} + 0.5 \text{ V}$	-
D	$U_{IN} = V_{DDM} + 0.75 \text{ V}$	-

**Table 3-4 PN-Junction Characteristics for negative Overload**

Pad Type	$I_{IN} = -3 \text{ mA}$	$I_{IN} = -5 \text{ mA}$
F / A2	$U_{IN} = V_{SS} - 0.5 \text{ V}$	$U_{IN} = V_{SS} - 0.6 \text{ V}$
LP / MP / MP+ / MPR	$U_{IN} = V_{SS} - 0.75 \text{ V}$	$U_{IN} = V_{SS} - 0.8 \text{ V}$
LVDSM	$U_{IN} = V_{SS} - 0.75 \text{ V}$	-
LVDSH	$U_{IN} = V_{SS} - 0.5 \text{ V}$	-
D	$U_{IN} = V_{SS} - 0.75 \text{ V}$	-

### 3.4 Operating Conditions

The following operating conditions must not be exceeded in order to ensure correct operation and reliability of the TC270 / TC275 / TC277. All parameters specified in the following tables refer to these operating conditions, unless otherwise noticed.

Digital supply voltages applied to the TC270 / TC275 / TC277 must be static regulated voltages.

All parameters specified in the following tables refer to these operating conditions (see table below), unless otherwise noticed in the Note / Test Condition column.

**Table 3-5 Operating Conditions**

Parameter	Symbol	Values			Unit	Note / Test Condition
		Min.	Typ.	Max.		
SRI frequency	$f_{SRI}$ SR	-	-	200	MHz	
Max System Frequency	$f_{MAX}$ SR	-	-	200	MHz	
CPU0 Frequency	$f_{CPU0}$ SR	-	-	200	MHz	
CPU1 Frequency	$f_{CPU1}$ SR	-	-	200	MHz	
CPU2 Frequency	$f_{CPU2}$ SR	-	-	200	MHz	
PLL output frequency	$f_{PLL}$ SR	20	-	200	MHz	
PLL_ERAY output frequency	$f_{PLLERAY}$ SR	20	-	400	MHz	
SPB frequency	$f_{SPB}$ SR	-	-	100	MHz	
ASCLIN fast frequency	$f_{ASCLINF}$ SR	-	-	200	MHz	
ASCLIN slow frequency	$f_{ASCLINS}$ SR	-	-	100	MHz	
Baud2 frequency	$f_{BAUD2}$ SR	-	-	200	MHz	
Baud1 frequency	$f_{BAUD1}$ SR	-	-	100	MHz	
FSI2 frequency	$f_{FSI2}$ SR	-	-	200	MHz	
FSI frequency	$f_{FSI}$ SR	-	-	100	MHz	
GTM frequency	$f_{GTM}$ SR	-	-	100	MHz	
STM frequency	$f_{STM}$ SR	-	-	100	MHz	
ERAY frequency	$f_{ERAY}$ SR	-	-	80	MHz	
BBB frequency	$f_{BBB}$ SR	-	-	100	MHz	
MultiCAN frequency	$f_{CAN}$ SR	-	-	100	MHz	
Absolute sum of short circuit currents of the device	$\Sigma I_{SC\_D}$ SR	-	-	100	mA	
Ambient Temperature	$T_A$ SR	-40	-	125	°C	valid for all SAK products
		-40	-	150	°C	valid for all SAL products
		-40	-	170	°C	valid for all SAL products without package
Junction Temperature	$T_J$ SR	-40	-	150	°C	valid for all SAK products
		-40	-	170	°C	valid for all SAL products

**Electrical Specification Operating Conditions**
**Table 3-5 Operating Conditions (cont'd)**

Parameter	Symbol	Values			Unit	Note / Test Condition
		Min.	Typ.	Max.		
Core Supply Voltage <sup>1)</sup>	$V_{DD}$ SR	1.17	1.3	1.43 <sup>2)</sup>	V	Only required if externally supplied
ADC analog supply voltage	$V_{DDM}$ SR	2.97	5.0	5.5 <sup>3)</sup>	V	
Digital external supply voltage for LP, MP, MP+ and LVDSM pads and EVR <sup>4)</sup>	$V_{EXT}$ SR	2.97	-	4.5	V	3.3V pad parameters are valid
		4.5	5.0	5.5 <sup>3)</sup>	V	5V pad parameters are valid
Digital supply voltage for Flex port	$V_{FLEX}$ SR	2.97	-	4.5	V	3.3V pad parameters are valid
		4.5	5.0	5.5 <sup>3)</sup>	V	5V pad parameters are valid
Digital supply voltage for LVDSH and A2 pads <sup>5)</sup>	$V_{DDP3}$ SR	2.97	3.3	3.63 <sup>6)</sup>	V	3.3V pad parameters are valid; only required if externally supplied
Flash supply voltage 3.3V <sup>1)</sup>	$V_{DDFL3}$ SR	2.97	3.3	3.63	V	Only required if externally supplied
Digital ground voltage	$V_{SS}$ SR	0	-	-	V	
Analog ground voltage for $V_{DDM}$	$V_{SSM}$ CC	-0.1	0	0.1	V	
Voltage to ensure defined pad states <sup>7)</sup>	$V_{DDPPA}$ CC	0.72	-	-	V	A2 and LVDSH
		1.4	-	-	V	LP, MP, MP+, MPR and LVDSM
Digital external supply voltage for EVR and during Standby mode	$V_{EVRSB}$ SR	2.97	-	5.5	V	only available in BGA package. $V_{EVRSB}$ is bonded together with $V_{EXT}$ supply pin in LQFP package.

- 1) No external inductive load permissible if EVR is used. All  $V_{DD}$  pins shall be connected together externally on the PCB.
- 2) Voltage overshoot to 1.69V is permissible, provided the duration is less than 2h cumulated. Reduced ADC accuracy and leakage is increased.
- 3) Voltage overshoot to 6.5V is permissible, provided the duration is less than 2h cumulated. Reduced ADC accuracy and leakage is increased.
- 4) All  $V_{EXT}$  pins shall be connected together externally on the PCB.
- 5) All  $V_{DDP3}$  pins shall be connected together externally on the PCB.
- 6) Voltage overshoot to 4.29V is permissible, provided the duration is less than 2h cumulated. Reduced ADC accuracy and leakage is increased.
- 7) This parameter is valid under the assumption the PORST signal is constantly at low level during the power-up/power-down of  $V_{DDP3}$ .

### 3.5 5 V / 3.3 V switchable Pads

Pad classes LP, MP, MP+, and MPR support both Automotive Level (AL) or TTL level (TTL) operation. Parameters are defined for AL operation and degrade in TTL operation.

**Table 3-6 Standard\_Pads**

Parameter	Symbol	Values			Unit	Note / Test Condition
		Min.	Typ.	Max.		
Pin capacitance (digital inputs/outputs)	$C_{IO}$ CC	-	6	10	pF	
Spike filter always blocked pulse duration	$t_{SF1}$ CC	-	-	80	ns	PORST only
Spike filter pass-through pulse duration	$t_{SF2}$ CC	220	-	-	ns	PORST only
PORST pad output current <sup>1)</sup>	$I_{PORST}$ CC	11	-	-	mA	$V_{EXT} = 3.0V$ ; $V_{PORST} = 0.9V$ ; $T_J = 165^{\circ}C$
		13	-	-	mA	$V_{EXT} = 4.5V$ ; $V_{PORST} = 1.0V$

1) Pull-down with  $I_{PORST}$  relevant is always activated when a primary supply monitor detects a violation.

**Table 3-7 Class LP 5V**

Parameter	Symbol	Values			Unit	Note / Test Condition
		Min.	Typ.	Max.		
Input frequency	$f_{IN}$ SR	-	-	75	MHz	Hysteresis active
		-	-	150	MHz	Hysteresis inactive
Input Hysteresis for LP pad <sup>1)</sup>	$HYSLP$ CC	0.09 * $V_{EXT/FLEX}$	-	-	V	AL
		0.075 * $V_{EXT/FLEX}$	-	-	V	TTL
Input Leakage current for LP pad	$I_{OZLP}$ CC	-150	-	150	nA	$(0.1 * V_{EXT/FLEX}) < V_{IN} < (0.9 * V_{EXT/FLEX})$
		-350	-	350	nA	else
Input leakage current for P32.0	$I_{OZP32.0}$ CC	-4900	-	4900	nA	$(0.1 * V_{EXT/FLEX}) < V_{IN} < (0.9 * V_{EXT/FLEX})$
		-9400	-	9400	nA	$(0.1 * V_{EXT/FLEX}) < V_{IN} < (0.9 * V_{EXT/FLEX})$ ; for $T_J > 150^{\circ}C$
		-5800	-	5800	nA	else
		-12000	-	12000	nA	else; for $T_J > 150^{\circ}C$
Pull-up current for LP pad	$I_{PUHLP}$ CC	30	-	-	$\mu A$	$V_{IHmin}$ ; AL
		43	-	-	$\mu A$	$V_{IHmin}$ ; TTL
		-	-	107	$\mu A$	$V_{ILmax}$ ; AL and TTL

**Electrical Specification 5 V / 3.3 V switchable Pads**
**Table 3-7 Class LP 5V (cont'd)**

Parameter	Symbol	Values			Unit	Note / Test Condition
		Min.	Typ.	Max.		
Pull-down current for LP pad	$I_{PDLLP}$ CC	-	-	100	$\mu\text{A}$	$V_{IHmin}$ ; AL and TTL
		46	-	-	$\mu\text{A}$	$V_{ILmax}$ ; AL
		21	-	-	$\mu\text{A}$	$V_{ILmax}$ ; TTL
On-Resistance for LP pad, weak driver <sup>2)</sup>	$R_{DSONLPW}$ CC	200	620	1040	Ohm	PMOS/NMOS ; $I_{OH}=0.5\text{mA}$ ; $I_{OL}=0.5\text{mA}$
On-Resistance for LP pad, medium driver <sup>2)</sup>	$R_{DSONLPM}$ CC	50	155	260	Ohm	PMOS/NMOS ; $I_{OH}=2\text{mA}$ ; $I_{OL}=2\text{mA}$
Rise / fall time for LP pad <sup>3)</sup>	$t_{LP}$ CC	-	-	$95+2.1 * C_L$	ns	$C_L \leq 50\text{pF}$ ; pin out driver=weak
		-	-	$200+2.9 * (C_L - 50)$	ns	$C_L \geq 50\text{pF}$ ; $C_L \leq 200\text{pF}$ ; pin out driver=weak
		-	-	$25+0.5 * C_L$	ns	$C_L \leq 50\text{pF}$ ; pin out driver=medium
		-	-	$50+0.75 * (C_L - 50)$	ns	$C_L \geq 50\text{pF}$ ; $C_L \leq 200\text{pF}$ ; pin out driver=medium
Input high voltage for LP pad	$V_{IHLP}$ SR	$(0.73 * V_{EX T/FLEX}) - 0.25$	-	-	V	Hysteresis active, AL
		$2.03$ <sup>4)</sup>	-	-	V	Hysteresis active, TTL
Input low voltage for LP pad	$V_{ILLP}$ SR	-	-	$(0.52 * V_{EX T/FLEX}) - 0.25$	V	Hysteresis active, AL
		-	-	$0.8$ <sup>5)</sup>	V	Hysteresis active, TTL
Input low / high voltage for LP pad	$V_{ILHLP}$ CC	1.85	-	3.0	V	Hysteresis inactive; not available for P14.2, P14.4, and P15.1
Pad set-up time for LP pad	$t_{SET\_LP}$ CC	-	-	100	ns	
Input leakage current for P02.1	$I_{OZ021}$ CC	-150	-	1030	nA	$(0.1 * V_{EXT/FLEX}) < V_{IN} < (0.9 * V_{EXT/FLEX})$ ; $T_J > 150^\circ\text{C}$
		-150	-	340	nA	$(0.1 * V_{EXT/FLEX}) < V_{IN} < (0.9 * V_{EXT/FLEX})$ ; $T_J = 150^\circ\text{C}$
		-420	-	1100	nA	else; $T_J > 150^\circ\text{C}$
		-350	-	380	nA	else; $T_J = 150^\circ\text{C}$
Pull down current for P32_0 pin	$I_{PDL P320}$ CC	-	-	105	$\mu\text{A}$	$V_{IHmin}$ ; AL and TTL
		41	-	-	$\mu\text{A}$	$V_{ILmax}$ ; AL
		16	-	-	$\mu\text{A}$	$V_{ILmax}$ ; TTL

**Electrical Specification 5 V / 3.3 V switchable Pads**
**Table 3-7 Class LP 5V (cont'd)**

Parameter	Symbol	Values			Unit	Note / Test Condition
		Min.	Typ.	Max.		
Pull Up Current for P32_0 pin	$I_{PUHP320}$ CC	25	-	-	$\mu\text{A}$	$V_{IHmin}$ : AL
		38	-	-	$\mu\text{A}$	$V_{IHmin}$ : TTL
		-	-	112	$\mu\text{A}$	$V_{ILmax}$ : AL and TTL
Short Circuit current for LP pad 6)	$I_{SC}$ SR	-10	-	10	mA	absolute max value (PSI5)
Deviation of symmetry for rising and falling edges	$SYM$ CC	-	-	20	%	

- 1) Hysteresis is implemented to avoid metastable states and switching due to internal ground bounce. It can't be guaranteed that it suppresses switching due to external system noise.
- 2) For currents smaller than the  $I_{OL/OH}$  from the test condition the defined Max. value stays unchanged.
- 3) Rise / fall times are defined 10% - 90% of  $V_{EXT/FLEX}$ .
- 4)  $V_{IHx} = 0.27 * V_{EXT/FLEX} + 0.545\text{V}$
- 5)  $V_{ILx} = 0.17 * V_{EXT/FLEX}$
- 6) The values are only valid if the pad is not used during operation, otherwise  $I_{SC}$  defines the limits for operation.

**Table 3-8 Class LP 3.3V**

Parameter	Symbol	Values			Unit	Note / Test Condition
		Min.	Typ.	Max.		
Input frequency	$f_{IN}$ SR	-	-	50	MHz	Hysteresis active
		-	-	100	MHz	Hysteresis inactive
Input Hysteresis for LP pad <sup>1)</sup>	$HYSLP$ CC	0.05 * $V_{EXT/FLEX}$	-	-	V	AL and TTL
Input Leakage current for LP pad	$I_{OZLP}$ CC	-150	-	150	nA	$(0.1 * V_{EXT/FLEX}) < V_{IN} < (0.9 * V_{EXT/FLEX})$
		-350	-	350	nA	else
Input leakage current for P32.0	$I_{OZP320}$ CC	-4900	-	4900	nA	$(0.1 * V_{EXT/FLEX}) < V_{IN} < (0.9 * V_{EXT/FLEX})$
		-9400	-	9400	nA	$(0.1 * V_{EXT/FLEX}) < V_{IN} < (0.9 * V_{EXT/FLEX})$ ; for $T_J > 150\text{ }^\circ\text{C}$
		-5800	-	5900	nA	else
		-12000	-	12000	nA	else; for $T_J > 150\text{ }^\circ\text{C}$
Pull-up current for LP pad	$I_{PUHLP}$ CC	17	-	-	$\mu\text{A}$	$V_{IHmin}$ : AL
		19	-	-	$\mu\text{A}$	$V_{IHmin}$ : TTL
		-	-	75	$\mu\text{A}$	$V_{ILmax}$ : AL and TTL
Pull-down current for LP pad	$I_{PDLLP}$ CC	-	-	75	$\mu\text{A}$	$V_{IHmin}$ : AL and TTL
		22	-	-	$\mu\text{A}$	$V_{ILmax}$ : AL
		11	-	-	$\mu\text{A}$	$V_{ILmax}$ : TTL
On-Resistance for LP pad, weak driver <sup>2)</sup>	$R_{DSONLPW}$ CC	250	875	1500	Ohm	; NMOS/PMOS ; $I_{OH}=0.25\text{mA}$ ; $I_{OL}=0.25\text{mA}$

**Electrical Specification 5 V / 3.3 V switchable Pads**
**Table 3-8 Class LP 3.3V (cont'd)**

Parameter	Symbol	Values			Unit	Note / Test Condition
		Min.	Typ.	Max.		
On-Resistance for LP pad, medium driver <sup>2)</sup>	$R_{DSONLPM}$ CC	70	235	400	Ohm	; NMOS/PMOS ; $I_{OH}=1mA$ ; $I_{OL}=1mA$
Rise / fall time for LP pad <sup>3)</sup>	$t_{LP}$ CC	-	-	$150+3.4 * C_L$	ns	$C_L \leq 50pF$ ; pin out driver=weak
		-	-	$320+4.5 * (C_L - 50)$	ns	$C_L \geq 50pF$ ; $C_L \leq 200pF$ ; pin out driver=weak
		-	-	$30+0.8 * C_L$	ns	$C_L \leq 50pF$ ; pin out driver=medium
		-	-	$70+1.1 * (C_L - 50)$	ns	$C_L \geq 50pF$ ; $C_L \leq 200pF$ ; pin out driver=medium
Input high voltage for LP pad	$V_{IHLP}$ SR	$(0.73 * V_{EX T/FLEX}) - 0.25$	-	-	V	Hysteresis active, AL
		$1.6$ <sup>4)</sup>	-	-	V	Hysteresis active, TTL
Input low voltage for LP pad	$V_{ILLP}$ SR	-	-	$(0.52 * V_{EX T/FLEX}) - 0.25$	V	Hysteresis active, AL
		-	-	$0.5$ <sup>5)</sup>	V	Hysteresis active, TTL
Input low / high voltage for LP pad	$V_{ILHLP}$ CC	1.1	-	1.9	V	Hysteresis inactive; not available for P14.2, P14.4, and P15.1
Pad set-up time for LP pad	$t_{SET\_LP}$ CC	-	-	100	ns	
Input leakage current for P02.1	$I_{OZ021}$ CC	-150	-	920	nA	$(0.1 * V_{EXT/FLEX}) < V_{IN} < (0.9 * V_{EXT/FLEX})$ ; $T_J > 150^\circ C$
		-150	-	330	nA	$(0.1 * V_{EXT/FLEX}) < V_{IN} < (0.9 * V_{EXT/FLEX})$ ; $T_J = 150^\circ C$
		-360	-	1000	nA	else; $T_J > 150^\circ C$
		-350	-	375	nA	else; $T_J = 150^\circ C$
Pull down current for P32_0 pin	$I_{PDLP320}$ CC	-	-	80	$\mu A$	$V_{IHmin}$ ; AL and TTL
		17	-	-	$\mu A$	$V_{ILmax}$ ; AL
		6	-	-	$\mu A$	$V_{ILmax}$ ; TTL
Pull Up Current for P32_0 pin	$I_{PUHP320}$ CC	12	-	-	$\mu A$	$V_{IHmin}$ ; AL
		14	-	-	$\mu A$	$V_{IHmin}$ ; TTL
		-	-	80	$\mu A$	$V_{ILmax}$ ; AL and TTL
Short Circuit current for LP pad <sup>6)</sup>	$I_{SC}$ SR	-10	-	10	mA	absolute max value (PSI5)
Deviation of symmetry for rising and falling edges	$SYM$ CC	-	-	20	%	

**Electrical Specification 5 V / 3.3 V switchable Pads**

- 1) Hysteresis is implemented to avoid metastable states and switching due to internal ground bounce. It can't be guaranteed that it suppresses switching due to external system noise.
- 2) For currents smaller than the  $I_{OL/OH}$  from the test condition the defined Max. value stays unchanged.
- 3) Rise / fall times are defined 10% - 90% of  $V_{EXT/FLEX}$ .
- 4)  $V_{IHx} = 0.27 * V_{EXT/FLEX} + 0.545V$
- 5)  $V_{ILx} = 0.17 * V_{EXT/FLEX}$
- 6) The values are only valid if the pad is not used during operation, otherwise  $I_{SC}$  defines the limits for operation.

**Table 3-9 Class MP 5V**

Parameter	Symbol	Values			Unit	Note / Test Condition
		Min.	Typ.	Max.		
Input frequency	$f_{IN}$ SR	-	-	75	MHz	Hysteresis active
		-	-	150	MHz	Hysteresis inactive
Input Hysteresis for MP pad <sup>1)</sup>	$HYSMP$ CC	0.09 * $V_{EXT/FLEX}$	-	-	V	AL
		0.075 * $V_{EXT/FLEX}$	-	-	V	TTL
Input Leakage current for MP pad	$I_{OZMP}$ CC	-500	-	500	nA	$(0.1 * V_{EXT/FLEX}) < V_{IN} < (0.9 * V_{EXT/FLEX})$
		-1000	-	1000	nA	else
Pull-up current for MP pad	$I_{PUHMP}$ CC	30	-	-	$\mu A$	$V_{IHmin}$ ; AL
		43	-	-	$\mu A$	$V_{IHmin}$ ; TTL
		-	-	107	$\mu A$	$V_{ILmax}$ ; AL and TTL
Pull-down current for MP pad	$I_{PDLMP}$ CC	-	-	100	$\mu A$	$V_{IHmin}$ ; AL and TTL
		46	-	-	$\mu A$	$V_{ILmax}$ ; AL
		21	-	-	$\mu A$	$V_{ILmax}$ ; TTL
On-Resistance for MP pad, weak driver <sup>2)</sup>	$R_{DSONMPW}$ CC	200	620	1040	Ohm	PMOS/NMOS ; $I_{OH}=0.5mA$ ; $I_{OL}=0.5mA$
On-Resistance for MP pad, medium driver <sup>2)</sup>	$R_{DSONMPM}$ CC	50	155	260	Ohm	PMOS/NMOS ; $I_{OH}=2mA$ ; $I_{OL}=2mA$
On-Resistance for MP pad, strong driver <sup>2)</sup>	$R_{DSONMPS}$ CC	20	75	130	Ohm	PMOS/NMOS ; $I_{OH}=8mA$ ; $I_{OL}=8mA$

**Electrical Specification 5 V / 3.3 V switchable Pads**
**Table 3-9 Class MP 5V (cont'd)**

Parameter	Symbol	Values			Unit	Note / Test Condition
		Min.	Typ.	Max.		
Rise / fall time for MP pad <sup>3)</sup>	$t_{MP\ CC}$	-	-	$95+2.1 \cdot C_L$	ns	$C_L \leq 50\text{pF}$ ; pin out driver=weak
		-	-	$200+2.9 \cdot (C_L-50)$	ns	$C_L \geq 50\text{pF}$ ; $C_L \leq 200\text{pF}$ ; pin out driver=weak
		-	-	$25+0.5 \cdot C_L$	ns	$C_L \leq 50\text{pF}$ ; pin out driver=medium
		-	-	$50 + 0.75 \cdot (C_L - 50)$	ns	$C_L \geq 50\text{pF}$ ; $C_L \leq 200\text{pF}$ ; pin out driver=medium
		-	-	$17.5+0.25 \cdot C_L$	ns	$C_L \leq 50\text{pF}$ ; edge=medium ; pin out driver=strong
		-	-	$30+0.3 \cdot (C_L-50)$	ns	$C_L \geq 50\text{pF}$ ; $C_L \leq 200\text{pF}$ ; edge=medium ; pin out driver=strong
		-	-	$7+0.2 \cdot C_L$	ns	$C_L \leq 50\text{pF}$ ; edge=sharp ; pin out driver=strong
		-	-	$17+0.3 \cdot (C_L-50)$	ns	$C_L \geq 50\text{pF}$ ; $C_L \leq 200\text{pF}$ ; edge=sharp ; pin out driver=strong
Input high voltage for MP pad	$V_{IHMP\ SR}$	$(0.73 \cdot V_{EXT/FLEX}) - 0.25$	-	-	V	Hysteresis active, AL
		$2.03$ <sup>4)</sup>	-	-	V	Hysteresis active, TTL
Input low voltage for MP pad	$V_{ILMP\ SR}$	-	-	$(0.52 \cdot V_{EXT/FLEX}) - 0.25$	V	Hysteresis active, AL
		-	-	$0.8$ <sup>5)</sup>	V	Hysteresis active, TTL
Input low / high voltage for MP pad	$V_{ILHMP\ CC}$	1.85	-	3.0	V	Hysteresis inactive
Pad set-up time for MP pad	$t_{SET\_MP\ CC}$	-	-	100	ns	
Short Circuit current for MP pad <sup>6)</sup>	$I_{SC\ SR}$	-10	-	10	mA	absolute max value (PSI5)
Deviation of symmetry for rising and falling edges	$SYM\ CC$	-	-	20	%	

1) Hysteresis is implemented to avoid metastable states and switching due to internal ground bounce. It can't be guaranteed that it suppresses switching due to external system noise.

2) For currents smaller than the  $I_{OL/OH}$  from the test condition the defined Max. value stays unchanged.

3) Rise / fall times are defined 10% - 90% of  $V_{EXT/FLEX}$ .

4)  $V_{IHx} = 0.27 \cdot V_{EXT/FLEX} + 0.545\text{V}$

5)  $V_{ILx} = 0.17 \cdot V_{EXT/FLEX}$

6) The values are only valid if the pad is not used during operation, otherwise  $I_{SC}$  defines the limits for operation.

**Electrical Specification 5 V / 3.3 V switchable Pads**
**Table 3-10 Class MP 3.3V**

Parameter	Symbol	Values			Unit	Note / Test Condition
		Min.	Typ.	Max.		
Input frequency	$f_{IN}$ SR	-	-	50	MHz	Hysteresis active
		-	-	100	MHz	Hysteresis inactive
Input Hysteresis for MP pad <sup>1)</sup>	$HYSMP$ CC	0.05 * $V_{EXT/FLEX}$	-	-	V	AL and TTL
Input Leakage current for MP pad	$I_{OZMP}$ CC	-500	-	500	nA	$(0.1 * V_{EXT/FLEX}) < V_{IN} < (0.9 * V_{EXT/FLEX})$
		-1000	-	1000	nA	else
Pull-up current for MP pad	$I_{PUHMP}$ CC	17	-	-	$\mu$ A	$V_{IHmin}$ ; AL
		19	-	-	$\mu$ A	$V_{IHmin}$ ; TTL
		-	-	75	$\mu$ A	$V_{ILmax}$ ; AL and TTL
Pull-down current for MP pad	$I_{PDLMP}$ CC	-	-	75	$\mu$ A	$V_{IHmin}$ ; AL and TTL
		22	-	-	$\mu$ A	$V_{ILmax}$ ; AL
		11	-	-	$\mu$ A	$V_{ILmax}$ ; TTL
On-Resistance for MP pad, weak driver <sup>2)</sup>	$R_{DSONMPW}$ CC	250	875	1500	Ohm	; NMOS/PMOS ; $I_{OH}=0.25mA$ ; $I_{OL}=0.25mA$
On-Resistance for MP pad, medium driver <sup>2)</sup>	$R_{DSONMPM}$ CC	70	235	400	Ohm	; NMOS/PMOS ; $I_{OH}=1mA$ ; $I_{OL}=1mA$
On-Resistance for MP pad, strong driver <sup>2)</sup>	$R_{DSONMPS}$ CC	20	110	200	Ohm	PMOS/NMOS ; $I_{OH}=4mA$ ; $I_{OL}=4mA$
Rise / fall time for MP pad <sup>3)</sup>	$t_{MP}$ CC	-	-	$150+3.4 * C_L$	ns	$C_L \leq 50pF$ ; pin out driver=weak
		-	-	$320+4.5 * (C_L-50)$	ns	$C_L \geq 50pF$ ; $C_L \leq 200pF$ ; pin out driver=weak
		-	-	$30+0.8 * C_L$	ns	$C_L \leq 50pF$ ; pin out driver=medium
		-	-	$70+1.1 * (C_L-50)$	ns	$C_L \geq 50pF$ ; $C_L \leq 200pF$ ; pin out driver=medium
		-	-	$32.5+0.35 * C_L$	ns	$C_L \leq 50pF$ ; edge=medium ; pin out driver=strong
		-	-	$50+0.45 * (C_L-50)$	ns	$C_L \geq 50pF$ ; $C_L \leq 200pF$ ; edge=medium ; pin out driver=strong
		-	-	$14.5+0.35 * C_L$	ns	$C_L \leq 50pF$ ; edge=sharp ; pin out driver=strong
		-	-	$32+0.5 * (C_L-50)$	ns	$C_L \geq 50pF$ ; $C_L \leq 200pF$ ; edge=sharp ; pin out driver=strong

**Electrical Specification 5 V / 3.3 V switchable Pads**
**Table 3-10 Class MP 3.3V (cont'd)**

Parameter	Symbol	Values			Unit	Note / Test Condition
		Min.	Typ.	Max.		
Input high voltage for MP pad	$V_{IHMP}$ SR	$(0.73 \cdot V_{EX})^{T/FLEX} - 0.25$	-	-	V	Hysteresis active, AL
		1.6 <sup>4)</sup>	-	-	V	Hysteresis active, TTL
Input low voltage for MP pad	$V_{ILMP}$ SR	-	-	$(0.52 \cdot V_{EX})^{T/FLEX} - 0.25$	V	Hysteresis active, AL
		-	-	0.5 <sup>5)</sup>	V	Hysteresis active, TTL
Input low / high voltage for MP pad	$V_{ILHMP}$ CC	1.1	-	1.9	V	Hysteresis inactive
Pad set-up time for MP pad	$t_{SET\_MP}$ CC	-	-	100	ns	
Short Circuit current for MP pad <sup>6)</sup>	$I_{SC}$ SR	-10	-	10	mA	absolute max value (PSI5)
Deviation of symmetry for rising and falling edges	$SYM$ CC	-	-	20	%	

- 1) Hysteresis is implemented to avoid metastable states and switching due to internal ground bounce. It can't be guaranteed that it suppresses switching due to external system noise.
- 2) For currents smaller than the  $I_{OL/OH}$  from the test condition the defined Max. value stays unchanged.
- 3) Rise / fall times are defined 10% - 90% of  $V_{EXT/FLEX}$ .
- 4)  $V_{IHx} = 0.27 \cdot V_{EXT/FLEX} + 0.545V$
- 5)  $V_{ILx} = 0.17 \cdot V_{EXT/FLEX}$
- 6) The values are only valid if the pad is not used during operation, otherwise  $I_{SC}$  defines the limits for operation.

**Table 3-11 Class MP+ 5V**

Parameter	Symbol	Values			Unit	Note / Test Condition
		Min.	Typ.	Max.		
Input frequency	$f_{IN}$ SR	-	-	75	MHz	Hysteresis active
		-	-	150	MHz	Hysteresis inactive
Input hysteresis for MP+ pad <sup>1)</sup>	$HYSMPP$ CC	$0.09 \cdot V_{EXT/FLEX}$	-	-	V	AL
		$0.075 \cdot V_{EXT/FLEX}$	-	-	V	TTL
Input leakage current for MP+ pad	$I_{OZMPP}$ CC	-750	-	750	nA	$(0.1 \cdot V_{EXT/FLEX}) < V_{IN} < (0.9 \cdot V_{EXT/FLEX})$
		-1500	-	1500	nA	else
Pull-up current for MP+ pad	$I_{PUHMPP}$ CC	30	-	-	$\mu A$	$V_{IHmin}$ ; AL
		43	-	-	$\mu A$	$V_{IHmin}$ ; TTL
		-	-	107	$\mu A$	$V_{ILmax}$ ; AL and TTL
Pull-down current for MP+ pad	$I_{PDLMPP}$ CC	-	-	100	$\mu A$	$V_{IHmin}$ ; AL and TTL
		46	-	-	$\mu A$	$V_{ILmax}$ ; AL
		21	-	-	$\mu A$	$V_{ILmax}$ ; TTL

**Electrical Specification 5 V / 3.3 V switchable Pads**
**Table 3-11 Class MP+ 5V (cont'd)**

Parameter	Symbol	Values			Unit	Note / Test Condition
		Min.	Typ.	Max.		
On-resistance for MP+ pad, weak driver <sup>2)</sup>	$R_{DSONMPPW}$ CC	200	620	1040	Ohm	PMOS/NMOS ; $I_{OH}=0.5mA$ ; $I_{OL}=0.5mA$
On-resistance for MP+ pad, medium driver <sup>2)</sup>	$R_{DSONMPPM}$ CC	50	155	260	Ohm	PMOS/NMOS ; $I_{OH}=2mA$ ; $I_{OL}=2mA$
On-resistance for MP+ pad, strong driver <sup>2)</sup>	$R_{DSONMPPS}$ CC	20	55	90	Ohm	PMOS/NMOS ; $I_{OH}=8mA$ ; $I_{OL}=8mA$
Rise/fall time for MP+ pad <sup>3)</sup>	$t_{MPP}$ CC	-	-	$95+2.1 \cdot C_L$	ns	$C_L \leq 50pF$ ; pin out driver=weak
		-	-	$200+2.9 \cdot (C_L-50)$	ns	$C_L \geq 50pF$ ; $C_L \leq 200pF$ ; pin out driver=weak
		-	-	$25+0.5 \cdot C_L$	ns	$C_L \leq 50pF$ ; pin out driver=medium
		-	-	$50+0.75 \cdot (C_L-50)$	ns	$C_L \geq 50pF$ ; $C_L \leq 200pF$ ; pin out driver=medium
		-	-	$9+0.16 \cdot C_L$	ns	$C_L \leq 50pF$ ; edge=medium ; pin out driver=strong
		-	-	$17+0.2 \cdot (C_L-50)$	ns	$C_L \geq 50pF$ ; $C_L \leq 200pF$ ; edge=medium ; pin out driver=strong
		-	-	$4+0.16 \cdot C_L$	ns	$C_L \leq 50pF$ ; edge=sharp ; pin out driver=strong
		-	-	$12+0.21 \cdot (C_L-50)$	ns	$C_L \geq 50pF$ ; $C_L \leq 200pF$ ; edge=sharp ; pin out driver=strong
		-	-	5	ns	from 0.8V to 2.0V (RMII) ; $C_L=25pF$ ; edge=sharp ; pin out driver=strong
		-	-	4.5	ns	$C_L=15pF$ ; edge=sharp ; pin out driver=strong
Input high voltage for MP+ pad	$V_{IHMPP}$ SR	$(0.73 \cdot V_{EX} - 0.25)$ $T/FLEX)$	-	-	V	Hysteresis active, AL
		2.03 <sup>4)</sup>	-	-	V	Hysteresis active, TTL
Input low voltage for MP+ pad	$V_{ILMPP}$ SR	-	-	$(0.52 \cdot V_{EX} - 0.25)$ $T/FLEX)$	V	Hysteresis active, AL
		-	-	0.8 <sup>5)</sup>	V	Hysteresis active, TTL
Input low / high voltage for MP+ pad	$V_{ILHMPP}$ CC	1.85	-	3.0	V	Hysteresis inactive

**Electrical Specification 5 V / 3.3 V switchable Pads**
**Table 3-11 Class MP+ 5V (cont'd)**

Parameter	Symbol	Values			Unit	Note / Test Condition
		Min.	Typ.	Max.		
Pad set-up time for MP+ pad	$t_{SET\_MPP}$ CC	-	-	100	ns	
Short circuit current for MP+ pad <sup>6)</sup>	$I_{SCMPP}$ SR	-10	-	10	mA	absolute max value (PSI5)
Deviation of symmetry for rising and falling edges	$SYM$ CC	-	-	20	%	

- 1) Hysteresis is implemented to avoid metastable states and switching due to internal ground bounce. It can't be guaranteed that it suppresses switching due to external system noise.
- 2) For currents smaller than the  $I_{OL/OH}$  from the test condition the defined Max. value stays unchanged.
- 3) Rise / fall times are defined 10% - 90% of  $V_{EXT/FLEX}$ .
- 4)  $V_{IHx} = 0.27 * V_{EXT/FLEX} + 0.545V$
- 5)  $V_{ILx} = 0.17 * V_{EXT/FLEX}$
- 6) The values are only valid if the pad is not used during operation, otherwise  $I_{SC}$  defines the limits for operation.

**Table 3-12 Class MP+ 3.3V**

Parameter	Symbol	Values			Unit	Note / Test Condition
		Min.	Typ.	Max.		
Input frequency	$f_{IN}$ SR	-	-	50	MHz	Hysteresis active
		-	-	100	MHz	Hysteresis inactive
Input hysteresis for MP+ pad <sup>1)</sup>	$HYSMPP$ CC	0.05 * $V_{EXT/FLEX}$	-	-	V	AL and TTL
Input leakage current for MP+ pad	$I_{OZMPP}$ CC	-750	-	750	nA	$(0.1 * V_{EXT/FLEX}) < V_{IN} < (0.9 * V_{EXT/FLEX})$
		-1500	-	1500	nA	else
Pull-up current for MP+ pad	$I_{PUHMPP}$ CC	17	-	-	$\mu A$	$V_{IHmin}$ ; AL
		19	-	-	$\mu A$	$V_{IHmin}$ ; TTL
		-	-	75	$\mu A$	$V_{ILmax}$ ; AL and TTL
Pull-down current for MP+ pad	$I_{PDLMPP}$ CC	-	-	75	$\mu A$	$V_{IHmin}$ ; AL and TTL
		22	-	-	$\mu A$	$V_{ILmax}$ ; AL
		11	-	-	$\mu A$	$V_{ILmax}$ ; TTL
On-resistance for MP+ pad, weak driver <sup>2)</sup>	$R_{DSONMPPW}$ CC	250	875	1500	Ohm	; NMOS/PMOS ; $I_{OH}=0.25mA$ ; $I_{OL}=0.25mA$
On-resistance for MP+ pad, medium driver <sup>2)</sup>	$R_{DSONMPPM}$ CC	70	235	400	Ohm	; NMOS/PMOS ; $I_{OH}=1mA$ ; $I_{OL}=1mA$
On-resistance for MP+ pad, strong driver <sup>2)</sup>	$R_{DSONMPPS}$ CC	20	75	130	Ohm	PMOS/NMOS ; $I_{OH}=4mA$ ; $I_{OL}=4mA$

**Electrical Specification 5 V / 3.3 V switchable Pads**
**Table 3-12 Class MP+ 3.3V (cont'd)**

Parameter	Symbol	Values			Unit	Note / Test Condition
		Min.	Typ.	Max.		
Rise/fall time for MP+ pad <sup>3)</sup>	$t_{MPP\ CC}$	-	-	150+3.4* $C_L$	ns	$C_L \leq 50\text{pF}$ ; pin out driver=weak
		-	-	320+4.5*( $C_L-50$ )	ns	$C_L \geq 50\text{pF}$ ; $C_L \leq 200\text{pF}$ ; pin out driver=weak
		-	-	30+0.8* $C_L$	ns	$C_L \leq 50\text{pF}$ ; pin out driver=medium
		-	-	70+1.1*( $C_L-50$ )	ns	$C_L \geq 50\text{pF}$ ; $C_L \leq 200\text{pF}$ ; pin out driver=medium
		-	-	20+0.2* $C_L$	ns	$C_L \leq 50\text{pF}$ ; edge=medium ; pin out driver=strong
		-	-	30+0.3*( $C_L-50$ )	ns	$C_L \geq 50\text{pF}$ ; $C_L \leq 200\text{pF}$ ; edge=medium ; pin out driver=strong
		-	-	13+0.2* $C_L$	ns	$C_L \leq 50\text{pF}$ ; edge=sharp ; pin out driver=strong
		-	-	23+0.3*( $C_L-50$ )	ns	$C_L \geq 50\text{pF}$ ; $C_L \leq 200\text{pF}$ ; edge=sharp ; pin out driver=strong
		-	-	5	ns	from 0.8V to 2.0V (RMII) ; $C_L=25\text{pF}$ ; edge=sharp ; pin out driver=strong
		-	-	4.5	ns	from 0.2 * $V_{EXT/FLEX}$ to 0.8 * $V_{EXT/FLEX}$ ; $C_L=15\text{pF}$ ; edge=sharp ; pin out driver=strong
Input high voltage for MP+ pad	$V_{IHMPPP\ SR}$	(0.73* $V_{EX}$ $T/FLEX$ )- 0.25	-	-	V	Hysteresis active, AL
		1.6 <sup>4)</sup>	-	-	V	Hysteresis active, TTL
Input low voltage for MP+ pad	$V_{ILMPP\ SR}$	-	-	(0.52* $V_{EX}$ $T/FLEX$ )- 0.25	V	Hysteresis active, AL
		-	-	0.5 <sup>5)</sup>	V	Hysteresis active, TTL
Input low / high voltage for MP+ pad	$V_{ILHMPPP\ CC}$	1.1	-	1.9	V	Hysteresis inactive
Pad set-up time for MP+ pad	$t_{SET\_MPP\ CC}$	-	-	100	ns	
Short circuit current for MP+ pad <sup>6)</sup>	$I_{SCMPP\ SR}$	-10	-	10	mA	absolute max value (PSI5)
Deviation of symmetry for rising and falling edges	$SYM\ CC$	-	-	20	%	

**Electrical Specification 5 V / 3.3 V switchable Pads**

- 1) Hysteresis is implemented to avoid metastable states and switching due to internal ground bounce. It can't be guaranteed that it suppresses switching due to external system noise.
- 2) For currents smaller than the  $I_{OL/OH}$  from the test condition the defined Max. value stays unchanged.
- 3) Rise / fall times are defined 10% - 90% of  $V_{EXT/FLEX}$ .
- 4)  $V_{IHx} = 0.27 * V_{EXT/FLEX} + 0.545V$
- 5)  $V_{ILx} = 0.17 * V_{EXT/FLEX}$
- 6) The values are only valid if the pad is not used during operation, otherwise  $I_{SC}$  defines the limits for operation.

**Table 3-13 Class MPR 5V**

Parameter	Symbol	Values			Unit	Note / Test Condition
		Min.	Typ.	Max.		
Input frequency	$f_{IN}$ SR	-	-	75	MHz	Hysteresis active
		-	-	150	MHz	Hysteresis inactive
Input Hysteresis for MPR pads 1)	$HYSMPR$ CC	0.09 * $V_{EXT/FLEX}$	-	-	V	AL
		0.075* $V_{EXT/FLEX}$	-	-	V	TTL
Input leakage current class MPR	$I_{OZMPR}$ CC	-750	-	750	nA	$(0.1 * V_{EXT/FLEX}) < V_{IN} < (0.9 * V_{EXT/FLEX})$
		-1500	-	1500	nA	else
Pull-up current	$I_{PUHMPR}$ CC	30	-	-	$\mu A$	$V_{IHmin}$ ; AL
		43	-	-	$\mu A$	$V_{IHmin}$ ; TTL
		-	-	107	$\mu A$	$V_{ILmax}$ ; AL and TTL
Pull-down current	$I_{PDLMPR}$ CC	-	-	100	$\mu A$	$V_{IHmin}$ ; AL and TTL
		46	-	-	$\mu A$	$V_{ILmax}$ ; AL
		21	-	-	$\mu A$	$V_{ILmax}$ ; TTL
On-resistance of the MPR pad, weak driver 2)	$R_{DSONMPRW}$ CC	200	620	1040	Ohm	PMOS/NMOS ; $I_{OH}=0.5mA$ ; $I_{OL}=0.5mA$
On-resistance of the MPR pad, medium driver 2)	$R_{DSONMPRM}$ CC	50	155	260	Ohm	PMOS/NMOS ; $I_{OH}=2mA$ ; $I_{OL}=2mA$
On-resistance of the MPR pad, strong driver 2)	$R_{DSONMPRS}$ CC	20	55	90	Ohm	PMOS/NMOS ; $I_{OH}=8mA$ ; $I_{OL}=8mA$

**Electrical Specification 5 V / 3.3 V switchable Pads**
**Table 3-13 Class MPR 5V (cont'd)**

Parameter	Symbol	Values			Unit	Note / Test Condition
		Min.	Typ.	Max.		
Rise/fall time <sup>3)</sup>	$t_{MPR\ CC}$	-	-	$95+2.1 \cdot C_L$	ns	$C_L \leq 50\text{pF}$ ; pin out driver=weak
		-	-	$200+2.9 \cdot (C_L-50)$	ns	$C_L \geq 50\text{pF}$ ; $C_L \leq 200\text{pF}$ ; pin out driver=weak
		-	-	$25+0.5 \cdot C_L$	ns	$C_L \leq 50\text{pF}$ ; pin out driver=medium
		-	-	$50+0.75 \cdot (C_L-50)$	ns	$C_L \geq 50\text{pF}$ ; $C_L \leq 200\text{pF}$ ; pin out driver=medium
		-	-	$9+0.16 \cdot C_L$	ns	$C_L \geq 0\text{pF}$ ; $C_L \leq 50\text{pF}$ ; edge=medium ; pin out driver=strong
		-	-	$17+0.2 \cdot (C_L-50)$	ns	$C_L \geq 50\text{pF}$ ; $C_L \leq 200\text{pF}$ ; edge=medium ; pin out driver=strong
		-	-	$4+0.16 \cdot C_L$	ns	$C_L \leq 50\text{pF}$ ; edge=sharp ; pin out driver=strong
		-	-	$12+0.21 \cdot (C_L-50)$	ns	$C_L \geq 50\text{pF}$ ; $C_L \leq 200\text{pF}$ ; edge=sharp ; pin out driver=strong
		-	-	5	ns	from 0.8V to 2.0V (RMII) ; $C_L=25\text{pF}$ ; edge=sharp ; pin out driver=strong
		-	-	4.5	ns	from $0.2 \cdot V_{EXT/FLEX}$ to $0.8 \cdot V_{EXT/FLEX}$ ; $C_L=15\text{pF}$ ; edge=sharp ; pin out driver=strong
Input high voltage, class MPR pads	$V_{IHMPR\ SR}$	$(0.73 \cdot V_{EX\ T/FLEX}) - 0.25$	-	-	V	Hysteresis active, AL
		2.03 <sup>4)</sup>	-	-	V	Hysteresis active, TTL
Input low voltage, class MPR pads	$V_{ILMPR\ SR}$	-	-	$(0.52 \cdot V_{EX\ T/FLEX}) - 0.25$	V	Hysteresis active, AL
		-	-	0.8 <sup>5)</sup>	V	Hysteresis active, TTL
Input low / high voltage, class MPR pads	$V_{ILHMPR\ SR}$	1.2	-	2.3	V	Hysteresis inactive
Pad set-up time	$t_{SET\_MPR\ CC}$	-	-	100	ns	
Short circuit current Class MPR	$I_{SC\ SR}$	-10	-	10	mA	absolute max value (PSI5)
Deviation of symmetry for rising and falling edges	$SYM\ CC$	-	-	20	%	

**Electrical Specification 5 V / 3.3 V switchable Pads**

- 1) Hysteresis is implemented to avoid metastable states and switching due to internal ground bounce. It can't be guaranteed that it suppresses switching due to external system noise.
- 2) For currents smaller than the  $I_{OL/OH}$  from the test condition the defined Max. value stays unchanged.
- 3) Rise / fall times are defined 10% - 90% of  $V_{EXT/FLEX}$ .
- 4)  $V_{IHx} = 0.27 * V_{EXT/FLEX} + 0.545V$
- 5)  $V_{ILx} = 0.17 * V_{EXT/FLEX}$

**Table 3-14 Class MPR 3.3V**

Parameter	Symbol	Values			Unit	Note / Test Condition
		Min.	Typ.	Max.		
Input frequency	$f_{IN}$ SR	-	-	50	MHz	Hysteresis active
		-	-	100	MHz	Hysteresis inactive
Input Hysteresis for MPR pads 1)	$HYSMPR$ CC	0.05 * $V_{EXT/FLEX}$	-	-	V	AL and TTL
Input leakage current class MPR	$I_{OZMPR}$ CC	-750	-	750	nA	$(0.1 * V_{EXT/FLEX}) < V_{IN} < (0.9 * V_{EXT/FLEX})$
		-1500	-	1500	nA	else
Pull-up current	$I_{PUHMPR}$ CC	17	-	-	$\mu A$	$V_{IHmin}$ ; AL
		19	-	-	$\mu A$	$V_{IHmin}$ ; TTL
		-	-	75	$\mu A$	$V_{ILmax}$ ; AL and TTL
Pull-down current	$I_{PDLMPR}$ CC	-	-	75	$\mu A$	$V_{IHmin}$ ; AL and TTL
		22	-	-	$\mu A$	$V_{ILmax}$ ; AL
		11	-	-	$\mu A$	$V_{ILmax}$ ; TTL
On-resistance of the MPR pad, weak driver 2)	$R_{DSONMPRW}$ CC	250	875	1500	Ohm	; NMOS/PMOS ; $I_{OH}=0.25mA$ ; $I_{OL}=0.25mA$
On-resistance of the MPR pad, medium driver 2)	$R_{DSONMPRM}$ CC	70	235	400	Ohm	; NMOS/PMOS ; $I_{OH}=1mA$ ; $I_{OL}=1mA$
On-resistance of the MPR pad, strong driver 2)	$R_{DSONMPRS}$ CC	20	75	130	Ohm	PMOS/NMOS ; $I_{OH}=4mA$ ; $I_{OL}=4mA$

**Electrical Specification 5 V / 3.3 V switchable Pads**
**Table 3-14 Class MPR 3.3V (cont'd)**

Parameter	Symbol	Values			Unit	Note / Test Condition
		Min.	Typ.	Max.		
Rise/fall time <sup>3)</sup>	$t_{MPR\ CC}$	-	-	$150+3.4 \cdot C_L$	ns	$C_L \leq 50\text{pF}$ ; pin out driver=weak
		-	-	$320+4.5 \cdot (C_L-50)$	ns	$C_L \geq 50\text{pF}$ ; $C_L \leq 200\text{pF}$ ; pin out driver=weak
		-	-	$30+0.8 \cdot C_L$	ns	$C_L \leq 50\text{pF}$ ; pin out driver=medium
		-	-	$70+1.1 \cdot (C_L-50)$	ns	$C_L \geq 50\text{pF}$ ; $C_L \leq 200\text{pF}$ ; pin out driver=medium
		-	-	$20+0.2 \cdot C_L$	ns	$C_L \geq 0\text{pF}$ ; $C_L \leq 50\text{pF}$ ; edge=medium ; pin out driver=strong
		-	-	$30+0.3 \cdot (C_L-50)$	ns	$C_L \geq 50\text{pF}$ ; $C_L \leq 200\text{pF}$ ; edge=medium ; pin out driver=strong
		-	-	$13+0.2 \cdot C_L$	ns	$C_L \leq 50\text{pF}$ ; edge=sharp ; pin out driver=strong
		-	-	$23+0.3 \cdot (C_L-50)$	ns	$C_L \geq 50\text{pF}$ ; $C_L \leq 200\text{pF}$ ; edge=sharp ; pin out driver=strong
		-	-	5	ns	from 0.8V to 2.0V (RMII) ; $C_L=25\text{pF}$ ; edge=sharp ; pin out driver=strong
		-	-	4.5	ns	from $0.2 \cdot V_{EXT/FLEX}$ to $0.8 \cdot V_{EXT/FLEX}$ ; $C_L=15\text{pF}$ ; edge=sharp ; pin out driver=strong
Input high voltage, class MPR pads	$V_{IHMPR\ SR}$	$(0.73 \cdot V_{EX\ T/FLEX}) - 0.25$	-	-	V	Hysteresis active, AL
		$1.6$ <sup>4)</sup>	-	-	V	Hysteresis active, TTL
Input low voltage, class MPR pads	$V_{ILMPR\ SR}$	-	-	$(0.52 \cdot V_{EX\ T/FLEX}) - 0.25$	V	Hysteresis active, AL
		-	-	$0.5$ <sup>5)</sup>	V	Hysteresis active, TTL
Input low / high voltage, class MPR pads	$V_{ILHMPR\ SR}$	0.8	-	1.7	V	Hysteresis inactive
Pad set-up time	$t_{SET\_MPR\ CC}$	-	-	100	ns	
Short circuit current Class MPR	$I_{SC\ SR}$	-10	-	10	mA	absolute max value (PSI5)

1) Hysteresis is implemented to avoid metastable states and switching due to internal ground bounce. It can't be guaranteed that it suppresses switching due to external system noise.

2) For currents smaller than the  $I_{OL/OH}$  from the test condition the defined Max. value stays unchanged.

**Electrical Specification 5 V / 3.3 V switchable Pads**

- 3) Rise / fall times are defined 10% - 90% of  $V_{EXT/FLEX}$ .  
 4)  $V_{IHx} = 0.27 * V_{EXT/FLEX} + 0.545V$   
 5)  $V_{ILx} = 0.17 * V_{EXT/FLEX}$

**Table 3-15 Class S**

Parameter	Symbol	Values			Unit	Note / Test Condition
		Min.	Typ.	Max.		
Input frequency	$f_{IN}$ SR	-	-	75	MHz	Hysteresis active
		-	-	150	MHz	Hysteresis inactive
Input Hysteresis for S pad <sup>1)</sup>	$HYS_S$ CC	0.3	-	-	V	
Pull-up current for S pad	$I_{PUHS}$ CC	30	-	-	$\mu A$	$V_{IHmin}$
		-	-	107	$\mu A$	$V_{ILmax}$
Pull-down current for S pad	$I_{PDL_S}$ CC	-	-	100	$\mu A$	$V_{IHmin}$
		46	-	-	$\mu A$	$V_{ILmax}$
Input Leakage current Class S	$I_{OZS}$ CC	-350	-	350	nA	Analog Inputs with pull down diagnostics
		-150	-	150	nA	else
Input voltage high for S pad	$V_{IHS}$ SR	-	-	$(0.73 * V_{DDM}) - 0.25$	V	Hysteresis active
Input voltage low for S pad	$V_{ILS}$ SR	$(0.52 * V_{DDM}) - 0.25$	-	-	V	Hysteresis active
Input low threshold variation for S pad <sup>2)</sup>	$V_{ILSD}$ SR	-50	-	50	mV	max. variation of 1ms; $V_{DDM} = \text{constant}$
Input capacitance for S pad	$C_{INS}$ CC	-	-	10	pF	
Pad set-up time for S pad	$t_{SETS}$ CC	-	-	100	ns	

- 1) Hysteresis is implemented to avoid metastable states and switching due to internal ground bounce. It can't be guaranteed that it suppresses switching due to external system noise.  
 2)  $V_{ILSD}$  is implemented to ensure J2716 specification. For details of dedicated pins please see AP32286 for details.

**Table 3-16 Class I 5V**

Parameter	Symbol	Values			Unit	Note / Test Condition
		Min.	Typ.	Max.		
Input frequency	$f_{IN}$ SR	-	-	75	MHz	Hysteresis active
		-	-	150	MHz	Hysteresis inactive
Input Hysteresis for I pad <sup>1)</sup>	$HYS_I$ CC	$0.07 * V_{EXT/FLEX}$	-	-	V	$\overline{PORST}$ pad only
		$0.09 * V_{EXT/FLEX}$	-	-	V	AL
		$0.075 * V_{EXT/FLEX}$	-	-	V	TTL
Pull-up current for I pad	$I_{PUHI}$ CC	30	-	-	$\mu A$	$V_{IHmin}$ ; AL
		43	-	-	$\mu A$	$V_{IHmin}$ ; TTL
		-	-	107	$\mu A$	$V_{ILmax}$ ; AL and TTL

**Electrical Specification 5 V / 3.3 V switchable Pads**
**Table 3-16 Class I 5V (cont'd)**

Parameter	Symbol	Values			Unit	Note / Test Condition
		Min.	Typ.	Max.		
Pull-down current for I pad	$I_{PDLI}$ CC	-	-	100	$\mu$ A	$V_{IHmin}$ : AL and TTL
		46	-	-	$\mu$ A	$V_{ILmax}$ : AL
		21	-	-	$\mu$ A	$V_{ILmax}$ : TTL
Input Leakage Current for I pad	$I_{OZI}$ CC	-150	-	150	nA	$(0.1 \cdot V_{EXT/FLEX}) < V_{IN} < (0.9 \cdot V_{EXT/FLEX})$
		-350	-	350	nA	else
Input high voltage for I pad	$V_{IHI}$ SR	2.03 <sup>2)</sup>	-	-	V	Hysteresis active, TTL
		$(0.73 \cdot V_{EXT/FLEX}) - 0.25$	-	-	V	Hysteresis active; AL; not available for the $\overline{PORST}$ pad
Input low voltage for I pad	$V_{ILI}$ SR	-	-	0.8 <sup>3)</sup>	V	Hysteresis active, TTL
		-	-	$(0.52 \cdot V_{EXT/FLEX}) - 0.25$	V	Hysteresis active; AL; not available for the $\overline{PORST}$ pad
Input low / high voltage for I pad	$V_{ILHI}$ CC	1.85	-	3.0	V	Hysteresis inactive
Pad set-up time for I pad	$t_{SETI}$ CC	-	-	100	ns	

1) Hysteresis is implemented to avoid metastable states and switching due to internal ground bounce. It can't be guaranteed that it suppresses switching due to external system noise.

2)  $V_{IHx} = 0.27 \cdot V_{EXT/FLEX} + 0.545V$

3)  $V_{ILx} = 0.17 \cdot V_{EXT/FLEX}$

**Table 3-17 Class I 3.3V**

Parameter	Symbol	Values			Unit	Note / Test Condition
		Min.	Typ.	Max.		
Input frequency	$f_{IN}$ SR	-	-	50	MHz	Hysteresis active
		-	-	100	MHz	Hysteresis inactive
Input Hysteresis for I pad <sup>1)</sup>	$HYSI$ CC	$0.045 \cdot V_{EXT/FLEX}$	-	-	V	$\overline{PORST}$ pad only
		$0.05 \cdot V_{EXT/FLEX}$	-	-	V	AL and TTL
Pull-up current for I pad	$I_{PUHI}$ CC	17	-	-	$\mu$ A	$V_{IHmin}$ : AL
		19	-	-	$\mu$ A	$V_{IHmin}$ : TTL
		-	-	75	$\mu$ A	$V_{ILmax}$ : AL and TTL
Pull-down current for I pad	$I_{PDLI}$ CC	-	-	75	$\mu$ A	$V_{IHmin}$ : AL and TTL
		22	-	-	$\mu$ A	$V_{ILmax}$ : AL
		11	-	-	$\mu$ A	$V_{ILmax}$ : TTL
Input Leakage Current for I pad	$I_{OZI}$ CC	-150	-	150	nA	$(0.1 \cdot V_{EXT/FLEX}) < V_{IN} < (0.9 \cdot V_{EXT/FLEX})$
		-350	-	350	nA	else

**Table 3-17 Class I 3.3V (cont'd)**

Parameter	Symbol	Values			Unit	Note / Test Condition
		Min.	Typ.	Max.		
Input high voltage for I pad	$V_{IHI}$ SR	1.6 <sup>2)</sup>	-	-	V	Hysteresis active, TTL
		$(0.73 * V_{EX} - 0.25)$ <small>T/FLEX)</small>	-	-	V	Hysteresis active; AL; not available for the $\overline{PORST}$ pad
Input low voltage for I pad	$V_{ILI}$ SR	-	-	0.5 <sup>3)</sup>	V	Hysteresis active, TTL
		-	-	$(0.52 * V_{EX} - 0.25)$ <small>T/FLEX)</small>	V	Hysteresis active; AL; not available for the $\overline{PORST}$ pad
Input low / high voltage for I pad	$V_{ILHI}$ CC	1.1	-	1.9	V	Hysteresis inactive
Pad set-up time for I pad	$t_{SETI}$ CC	-	-	100	ns	

- 1) Hysteresis is implemented to avoid metastable states and switching due to internal ground bounce. It can't be guaranteed that it suppresses switching due to external system noise.
- 2)  $V_{IHx} = 0.27 * V_{EXT/FLEX} + 0.545V$
- 3)  $V_{ILx} = 0.17 * V_{EXT/FLEX}$

**Table 3-18 Driver Mode Selection for LP Pads**

PDx.2	PDx.1	PDx.0	Port Functionality	Driver Setting
X	X	0	Speed grade 1	medium (LPm)
X	X	1	Speed grade 2	weak (LPw)

**Table 3-19 Driver Mode Selection for MP / MP+ Pads**

PDx.2	PDx.1	PDx.0	Port Functionality	Driver Setting
X	0	0	Speed grade 1	Strong sharp edge (MPss / MP+ss / MPRss)
X	0	1	Speed grade 2	Strong medium edge (MPsm / MP+sm)
X	1	0	Speed grade 3	medium (MPm / MP+m / MPRm)
X	1	1	Speed grade 4	weak (MPw / MP+w / MPRw)

### 3.6 3.3 V only Pads

Pad classes LP, MP and MP+ support both Automotive Level (AL) or TTL level (TTL) operation. Parameters are defined for AL operation and degrade in TTL operation.

**Table 3-20 Class A2**

Parameter	Symbol	Values			Unit	Note / Test Condition
		Min.	Typ.	Max.		
Input frequency	$f_{IN}$ SR	-	-	160	MHz	
Input Hysteresis for A2 pad <sup>1)</sup>	$HYS_{A2}$ CC	0.1 * $V_{DDP3}$	-	-	V	TTL; else
		0.06 * $V_{DDP3}$	-	-	V	valid for P21.6 and P21.7
Input Leakage current for A2 pad	$I_{OZA2}$ CC	-300	-	300	nA	$(0.1 * V_{EXT/FLEX}) < V_{IN} < (0.9 * V_{EXT/FLEX})$
		-800	-	500	nA	else
Pull-up current for A2 pad	$I_{PUHA2}$ CC	-	-	100	$\mu$ A	$V_{IHmin}$
		25	-	-	$\mu$ A	$V_{ILmax}$
Pull-down current for A2 pad	$I_{PDLA2}$ CC	23	-	-	$\mu$ A	$V_{IHmin}$
		-	-	100	$\mu$ A	$V_{ILmax}$
On-Resistance for A2 pad, weak driver <sup>2)</sup>	$R_{DSONA2W}$ CC	100	200	325	Ohm	PMOS/NMOS ; $I_{OH}=0.5mA$ ; $I_{OL}=0.5mA$
On-Resistance for A2 pad, medium driver <sup>2)</sup>	$R_{DSONA2M}$ CC	40	70	100	Ohm	PMOS/NMOS ; $I_{OH}=2mA$ ; $I_{OL}=2mA$
On-Resistance for A2 pad, strong driver <sup>2)</sup>	$R_{DSONA2S}$ CC	20	35	50	Ohm	PMOS/NMOS ; $I_{OH}=8mA$ ; $I_{OL}=8mA$
Rise/fall time for A2 pad <sup>3)</sup>	$t_{A2}$ CC	-	-	$20+0.8 * C_L$	ns	$C_L \leq 50pF$ ; pin out driver=weak
		-	-	$17.5+0.85 * C_L$	ns	$C_L \geq 50pF$ ; $C_L \leq 200pF$ ; pin out driver=weak
		-	-	$12+0.16 * C_L$	ns	$C_L \leq 50pF$ ; pin out driver=medium
		-	-	$11.5+0.17 * C_L$	ns	$C_L \geq 50pF$ ; $C_L \leq 200pF$ ; pin out driver=medium
		-	-	$6+0.06 * C_L$	ns	$C_L \leq 50pF$ ; edge=medium ; pin out driver=strong
		-	-	$5.5+0.07 * C_L$	ns	$C_L \geq 50pF$ ; $C_L \leq 200pF$ ; edge=medium ; pin out driver=strong
		-	-	$0.0+0.12 * C_L$	ns	$C_L \leq 50pF$ ; edge=sharp ; pin out driver=strong
		-	-	$0.0+0.12 * C_L$	ns	$C_L \geq 50pF$ ; $C_L \leq 200pF$ ; edge=sharp ; pin out driver=strong

**Table 3-20 Class A2 (cont'd)**

Parameter	Symbol	Values			Unit	Note / Test Condition
		Min.	Typ.	Max.		
Input high voltage for A2 pad	$V_{IHA2}$ SR	2.04 <sup>4)</sup>	-	-	V	TTL; valid for all A2 pads except TMS/DAP1, TRST, and TCK/DAP0
		0.7 * $V_{DDP3}$	-	-	V	valid for TMS/DAP1, TRST, and TCK/DAP0
Input low voltage for A2 pad	$V_{ILA2}$ SR	-	-	0.8 <sup>5)</sup>	V	TTL; valid for all A2 pads except TMS/DAP1, TRST, and TCK/DAP0
		-	-	0.3 * $V_{DDP3}$	V	valid for TMS/DAP1, TRST, and TCK/DAP0
Pad set-up time for A2 pad	$t_{SETA2}$ CC	-	-	100	ns	
Deviation of symmetry for rising and falling edges	$SYM$ CC	-	-	20	%	

- 1) Hysteresis is implemented to avoid metastable states and switching due to internal ground bounce. It can't be guaranteed that it suppresses switching due to external system noise.
- 2) For currents smaller than the  $I_{OL/OH}$  from the test condition the defined Max. value stays unchanged.
- 3) Rise / fall times are defined 10% - 90% of  $V_{DDP3}$ .
- 4)  $V_{IHx} = 0.57 * V_{DDP3} - 0.03V$
- 5)  $V_{ILx} = 0.25 * V_{DDP3} + 0.058V$

**Table 3-21 Driver Mode Selection for A2 Pads**

PDx.2	PDx.1	PDx.0	Port Functionality	Driver Setting
X	0	0	Speed grade 1	Strong sharp edge
X	0	1	Speed grade 2	Strong medium edge
X	1	0	Speed grade 3	medium
X	1	1	Speed grade 4	weak

**Table 3-22 Driver Mode Selection for F Pads**

PDx.2	PDx.1	PDx.0	Port Functionality	Driver Setting
X	0	0	Speed grade 1	Reduced Strong sharp edge
X	0	1	Speed grade 2	Reduced Strong medium edge
X	1	0	Speed grade 3	medium
X	1	1	Speed grade 4	weak

### 3.7 High performance LVDS Pads (LVDSH)

This LVDS pad type is used for the high speed chip to chip communication interface of the new TC270 / TC275 / TC277. It compose out of a LVDSH pad and a Class F pad.

This pad combination is always supplied by the 3.3V supply rail.

**Table 3-23 Class F**

Parameter	Symbol	Values			Unit	Note / Test Condition
		Min.	Typ.	Max.		
Input frequency	$f_{IN}$ SR	-	-	75	MHz	
Input Hysteresis for F pad <sup>1)</sup>	$HYSF$ CC	0.1 * $V_{DDP3}$	-	-	V	TTL
Input Leakage Current for F pad	$I_{OZF}$ CC	-1000	-	1000	nA	$(0.1 * V_{DDP3}) < V_{IN} < (0.9 * V_{DDP3})$ ; valid for P21.2 and P21.3; $T_J = 150^\circ C$
		-1500	-	1500	nA	$(0.1 * V_{DDP3}) < V_{IN} < (0.9 * V_{DDP3})$ ; valid for P21.2 and P21.3; $T_J = 170^\circ C$
		-300	-	300	nA	$(0.1 * V_{DDP3}) < V_{IN} < (0.9 * V_{DDP3})$ ; valid for P21.4 and P21.5
		-2000	-	2000	nA	else; valid for P21.2 and P21.3; $T_J = 150^\circ C$
		-3000	-	3000	nA	else; valid for P21.2 and P21.3; $T_J = 170^\circ C$
		-600	-	600	nA	else; valid for P21.4 and P21.5
Pull-up current for F pad	$I_{PUHF}$ CC	25	-	-	$\mu A$	$V_{IHmin}$
		-	-	100	$\mu A$	$V_{ILmax}$
Pull-down current for class F pads	$I_{PDLF}$ CC	-	-	100	$\mu A$	$V_{IHmin}$
		25	-	-	$\mu A$	$V_{ILmax}$
On resistance for F pad, weak driver <sup>2)</sup>	$R_{DSONFW}$ CC	100	200	325	Ohm	PMOS/NMOS ; $I_{OH}=0.5mA$ ; $I_{OL}=0.5mA$
On resistance for F pad, medium driver <sup>2)</sup>	$R_{DSONFM}$ CC	40	70	100	Ohm	PMOS/NMOS ; $I_{OH}=2mA$ ; $I_{OL}=2mA$
On resistance for F pad, strong driver <sup>2)</sup>	$R_{DSONFS}$ CC	20	50	80	Ohm	PMOS/NMOS ; $I_{OH}=4mA$ ; $I_{OL}=4mA$

**Electrical Specification High performance LVDS Pads (LVDSH)**
**Table 3-23 Class F (cont'd)**

Parameter	Symbol	Values			Unit	Note / Test Condition
		Min.	Typ.	Max.		
Rise/fall time for F pad <sup>3)</sup>	$t_{\text{rff}}$ CC	-	-	$20+0.8 \cdot C_L$	ns	$C_L \leq 50\text{pF}$ ; pin out driver=weak
		-	-	$17.5+0.85 \cdot C_L$	ns	$C_L \geq 50\text{pF}$ ; $C_L \leq 200\text{pF}$ ; pin out driver=weak
		-	-	$12+0.16 \cdot C_L$	ns	$C_L \leq 50\text{pF}$ ; pin out driver=medium
		-	-	$11.5+0.17 \cdot C_L$	ns	$C_L \geq 50\text{pF}$ ; $C_L \leq 200\text{pF}$ ; pin out driver=medium
		-	-	$7+0.16 \cdot C_L$	ns	$C_L \leq 50\text{pF}$ ; edge=medium ; pin out driver=reduced strong
		-	-	$6.5+0.17 \cdot C_L$	ns	$C_L \geq 50\text{pF}$ ; $C_L \leq 200\text{pF}$ ; edge=medium ; pin out driver>reduced strong
		-	-	$4+0.16 \cdot C_L$	ns	$C_L \leq 50\text{pF}$ ; edge=sharp ; pin out driver=reduced strong
		-	-	$3.5+0.17 \cdot C_L$	ns	$C_L \geq 50\text{pF}$ ; $C_L \leq 200\text{pF}$ ; edge=sharp ; pin out driver=reduced strong
Input high voltage for F pad	$V_{\text{IHF}}$ SR	2.04 <sup>4)</sup>	-	-	V	TTL
Input low voltage for F pad	$V_{\text{ILF}}$ SR	-	-	0.8 <sup>5)</sup>	V	TTL
Pad set-up time for F pad	$t_{\text{SETF}}$ CC	-	-	100	ns	
Deviation of symmetry for rising and falling edges	$SYM$ CC	-	-	20	%	

1) Hysteresis is implemented to avoid metastable states and switching due to internal ground bounce. It can't be guaranteed that it suppresses switching due to external system noise.

2) For currents smaller than the  $I_{\text{OL/OH}}$  from the test condition the defined Max. value stays unchanged.

3) Rise / fall times are defined 10% - 90% of  $V_{\text{DDP3}}$ .

4)  $V_{\text{IHx}} = 0.57 \cdot V_{\text{DDP3}} - 0.03\text{V}$

5)  $V_{\text{ILx}} = 0.25 \cdot V_{\text{DDP3}} + 0.058\text{V}$

$C_L = 2.5 \text{ pF}$  for all LVDSH parameters.

**Table 3-24 LVDSH - IEEE standard LVDS general purpose link (GPL)**

Parameter	Symbol	Values			Unit	Note / Test Condition
		Min.	Typ.	Max.		
Output impedance	$R_0$ CC	40	-	140	Ohm	$V_{\text{cm}} = 1.0 \text{ V}$ and $1.4 \text{ V}$
Rise time <sup>1)</sup>	$t_{\text{rise20}}$ CC	-	-	0.5	ns	$Z_L = 100 \text{ Ohm} \pm 5\%$ @2 pF
Fall time <sup>1)</sup>	$t_{\text{fall20}}$ CC	-	-	0.5	ns	$Z_L = 100 \text{ Ohm} \pm 5\%$ @ 2 pF
Output differential voltage	$V_{\text{OD}}$ CC	250	-	400	mV	$RT = 100 \text{ Ohm} \pm 5\%$

**Electrical Specification High performance LVDS Pads (LVDSH)**
**Table 3-24 LVDSH - IEEE standard LVDS general purpose link (GPL) (cont'd)**

Parameter	Symbol	Values			Unit	Note / Test Condition
		Min.	Typ.	Max.		
Output voltage high	$V_{OH}$ CC	-	-	1475	mV	RT = 100 Ohm $\pm$ 5% (400 mV/2) + 1275 mV
Output voltage low	$V_{OL}$ CC	925	-	-	mV	RT = 100 Ohm $\pm$ 5%
Output offset (Common mode) voltage	$V_{OS}$ CC	1125	-	1275	mV	RT = 100 Ohm $\pm$ 5%
Input voltage range	$V_I$ SR	0	-	1600	mV	Driver ground potential difference < 925 mV; RT = 100 Ohm $\pm$ 10%
		0	-	2000	mV	Driver ground potential difference < 925 mV; RT = 100 Ohm $\pm$ 20%
Input differential threshold	$V_{idth}$ SR	-100	-	100	mV	Driver ground potential difference < 925 mV
Delta output impedance	$dR_O$ SR	-	-	10	%	$V_{cm}$ = 1.0 V and 1.4 V (mismatch Pd and Pn)
Change in VOS between 0 and 1	$dV_{OS}$ CC	-	-	25	mV	RT = 100 Ohm $\pm$ 5%
Change in Vod between 0 and 1	$dV_{od}$ CC	-	-	25	mV	RT = 100 Ohm $\pm$ 5%
Duty cycle	$t_{duty}$ CC	45	-	55	%	

 1) Rise / fall times are defined for 20% - 80% of  $V_{OD}$ 
**Table 3-25 LVDSH - IEEE standard LVDS reduced link (REDL)**

Parameter	Symbol	Values			Unit	Note / Test Condition
		Min.	Typ.	Max.		
Output impedance	$R_O$ CC	40	-	140	Ohm	$V_{cm}$ = 1.0 V and 1.4 V
Output differential voltage	$V_{OD}$ CC	150	-	250	mV	RT = 100 Ohm $\pm$ 5%
Output voltage high	$V_{OH}$ CC	-	-	1375	mV	RT = 100 Ohm $\pm$ 5%
Output voltage low	$V_{OL}$ CC	1025	-	-	mV	RT = 100 Ohm $\pm$ 5%
Output offset (Common mode) voltage	$V_{OS}$ CC	1125	-	1275	mV	RT = 100 Ohm $\pm$ 5%
Input voltage range	$V_I$ SR	825	-	1575	mV	Driver ground potential difference < 50 mV
Input differential threshold	$V_{idth}$ SR	-100	-	100	mV	Driver ground potential difference < 50 mV
Change in VOS between 0 and 1	$dV_{OS}$ CC	-	-	25	mV	RT = 100 Ohm $\pm$ 5%
Change in Vod between 0 and 1	$dV_{od}$ CC	-	-	25	mV	RT = 100 Ohm $\pm$ 5%
Duty cycle	$t_{duty}$ CC	45	-	55	%	

Electrical Specification High performance LVDS Pads (LVDSH)

Table 3-25 LVDSH - IEEE standard LVDS reduced link (REDL) (cont'd)

Parameter	Symbol	Values			Unit	Note / Test Condition
		Min.	Typ.	Max.		
$V_{OD}$ Fall time <sup>1)</sup>	$t_{fall10}$ CC	-	-	0.5	ns	ZL = 100 Ohm $\pm$ 5% @ 2pF
$V_{OD}$ Rise time <sup>1)</sup>	$t_{rise10}$ CC	-	-	0.5	ns	ZL = 100 Ohm $\pm$ 5% @ 2pF

1) Rise / fall times are defined for 10% - 90% of  $V_{OD}$

default after start-up = CMOS function

### 3.8 Medium performance LVDS Pads (LVDSM)

This LVDS pad type is used for the medium speed chip to chip communication interface of the new TC270 / TC275 / TC277. It compose out of a LVDSM pad and a MP pad.

This pad combination is always supplied by the 5V or 3.3V.

For the parameters of the MP pad please see [Chapter 3.5](#).

**Table 3-26 LVDSM**

Parameter	Symbol	Values			Unit	Note / Test Condition
		Min.	Typ.	Max.		
Output impedance	$R_O$ CC	40	100	140	Ohm	
Fall time	$t_F$ CC	-	-	2.5	ns	$Z_{load} = 100$ Ohm; termination 100 Ohm $\pm 1\%$
Rise time	$t_R$ CC	-	-	2.5	ns	$Z_{load} = 100$ Ohm; termination 100 Ohm $\pm 1\%$
Pad set-up time	$t_{SET\_LVDS}$ CC	-	10	13	$\mu s$	
Output Differential Voltage	$V_{OD}$ CC	250	-	400	mV	termination 100 Ohm $\pm 1\%$
Output voltage high	$V_{OH}$ CC	-	-	1475	mV	termination 100 Ohm $\pm 1\%$
Output voltage low	$V_{OL}$ CC	925	-	-	mV	termination 100 Ohm $\pm 1\%$
Output Offset Voltage	$V_{OS}$ CC	1125	-	1275	mV	termination 100 Ohm $\pm 1\%$

default after start-up = CMOS function

### 3.9 VADC Parameters

VADC parameter are valid for  $V_{DDM} = 4.5 \text{ V}$  to  $5.5 \text{ V}$ .

This tables also covers the parameters for Class D pads.

**Table 3-27 VADC**

Parameter	Symbol	Values			Unit	Note / Test Condition
		Min.	Typ.	Max.		
Analog reference voltage <sup>1)</sup>	$V_{AREF}$ SR	$V_{AGND} + 1.0$	-	$V_{DDM} + 0.05$	V	
Analog reference ground	$V_{AGND}$ SR	$V_{SSM} - 0.05$	-	$V_{SSM} + 0.05$	V	
Analog input voltage range	$V_{AIN}$ SR	$V_{AGND}$	-	$V_{AREF}$	V	
Converter reference clock	$f_{ADCI}$ SR	2	-	20	MHz	
Charge consumption per conversion <sup>2) 3)</sup>	$Q_{CONV}$ CC	-	50	75	pC	$V_{AIN} = 5 \text{ V}$ , charge consumed from reference pin, precharging disabled
		-	10	22	pC	$V_{AIN} = 5 \text{ V}$ , charge consumed from reference pin, precharging enabled
Conversion time for 12-bit result	$t_{C12}$ CC	-	$(16 + \text{STC}) \times t_{ADCI} + 2 \times t_{VADC}$	-		Includes sample time and post calibration
Conversion time for 10-bit result	$t_{C10}$ CC	-	$(14 + \text{STC}) \times t_{ADCI} + 2 \times t_{VADC}$	-		Includes sample time
Conversion time for 8-bit result	$t_{C8}$ CC	-	$(12 + \text{STC}) \times t_{ADCI} + 2 \times t_{VADC}$	-		Includes sample time
Conversion time for fast compare mode	$t_{CF}$ CC	-	$(4 + \text{STC}) \times t_{ADCI} + 2 \times t_{VADC}$	-		Includes sample time
Broken wire detection delay against $V_{AGND}$ <sup>4)</sup>	$t_{BWG}$ CC	-	-	120	cycles	Result below 10%
Broken wire detection delay against $V_{AREF}$ <sup>5)</sup>	$t_{BWR}$ CC	-	-	60	cycles	Result above 80%
Input leakage at analog inputs	$I_{OZ1}$ CC	-350	-	350	nA	Analog Inputs overlaid with class LP pads or pull down diagnostics
		-150	-	150	nA	else
Total Unadjusted Error <sup>1)</sup>	$TUE$ CC	$-4$ <sup>6)</sup>	-	$4$ <sup>6)</sup>	LSB	12-bit resolution

## Electrical Specification VADC Parameters

Table 3-27 VADC (cont'd)

Parameter	Symbol	Values			Unit	Note / Test Condition
		Min.	Typ.	Max.		
INL Error	$EA_{INL}$ CC	-3	-	3	LSB	12-bit resolution
Gain Error <sup>1)</sup>	$EA_{GAIN}$ CC	-3.5	-	3.5	LSB	12-bit resolution
DNL error <sup>1)</sup>	$EA_{DNL}$ CC	-3	-	3	LSB	12-bit resolution
Offset Error <sup>1)</sup>	$EA_{OFF}$ CC	-4	-	4	LSB	12-bit resolution
Total capacitance of an analog input	$C_{AINT}$ CC	-	-	30	pF	
Switched capacitance of an analog input	$C_{AINS}$ CC	2	4	7	pF	
Resistance of the analog input path	$R_{AIN}$ CC	-	-	1.5	kOhm	else
		-	-	1.8	kOhm	valid for analog inputs mapped to GPIOs
Switched capacitance of a reference input	$C_{AREFS}$ CC	-	-	30	pF	
RMS Noise <sup>7)</sup>	$EN_{RMS}$ CC	-	0.5	0.8 <sup>6)8)</sup>	LSB	
Positive reference $V_{AREFX}$ pin leakage	$I_{OZ2}$ CC	-7	-	7	$\mu A$	$V_{AREFX} = V_{AREF2};$ $V_{AREF} > V_{DDM}V;$ $T_J > 150^\circ C$
		-4	-	4	$\mu A$	$V_{AREFX} = V_{AREF2};$ $V_{AREF} > V_{DDM}V;$ $T_J \leq 150^\circ C$
		-2	-	3	$\mu A$	$V_{AREFX} = V_{AREF2};$ $V_{AREF} \leq V_{DDM}V;$ $T_J > 150^\circ C$
		-1	-	1	$\mu A$	$V_{AREFX} = V_{AREF2};$ $V_{AREF} \leq V_{DDM}V;$ $T_J \leq 150^\circ C$
Negative reference $V_{AGNDx}$ pin leakage	$I_{OZ3}$ CC	-13	-	13	$\mu A$	$V_{AGNDx} = V_{AGND2};$ $V_{AGND} < V_{SSM}V;$ $T_J > 150^\circ C$
		-7	-	7	$\mu A$	$V_{AGNDx} = V_{AGND2};$ $V_{AGND} < V_{SSM}V;$ $T_J \leq 150^\circ C$
		-3.3	-	2.5	$\mu A$	$V_{AGNDx} = V_{AGND2};$ $V_{AREF} \leq V_{DDM}V;$ $T_J > 150^\circ C$
		-2.85	-	1	$\mu A$	$V_{AGNDx} = V_{AGND2};$ $V_{AREF} \leq V_{DDM}V;$ $T_J \leq 150^\circ C$
Resistance of the reference input path	$R_{AREF}$ CC	-	-	1	kOhm	
CSD resistance <sup>9)</sup>	$R_{CSD}$ CC	-	-	28	kOhm	

**Electrical Specification VADC Parameters**
**Table 3-27 VADC (cont'd)**

Parameter	Symbol	Values			Unit	Note / Test Condition
		Min.	Typ.	Max.		
Resistance of the multiplexer diagnostics pull-down device	$R_{MDD}$ CC	$25 + 1 \cdot V_{IN}$	-	$35 - 8 \cdot V_{IN}$	kOhm	$0 V \leq V_{IN} \leq 2.5 V$
		$-5 + 13 \cdot V_{IN}$	-	$15 + 16 \cdot V_{IN}$	kOhm	$2.5 V \leq V_{IN} \leq V_{DDM}$
Resistance of the multiplexer diagnostics pull-up device	$R_{MDU}$ CC	$45 - 6 \cdot V_{IN}$	-	$90 - 16 \cdot V_{IN}$	kOhm	$0 V \geq V_{IN} \leq 2.5 V$
		$40 - 4 \cdot V_{IN}$	-	$65 - 6 \cdot V_{IN}$	kOhm	$2.5 V \leq V_{IN} \leq V_{DDM}$
Resistance of the pull-down test device <sup>10)</sup>	$R_{PDD}$ CC	-	-	0.3	kOhm	
CSD voltage accuracy <sup>11) 12)</sup>	$dVCSD$ CC	-	-	10	%	
Wakeup time	$t_{WU}$ CC	-	-	12	$\mu s$	

- 1) If the reference voltage is reduced by the factor k ( $k < 1$ ), TUE, DNL, INL, Gain, and Offset errors increase also by the factor  $1/k$ .  $V_{AREF}$  must be decoupled with an external capacitor.
- 2) For  $QCONV = X$  pC and a conversion time of  $1 \mu s$  a rms value of  $X \mu A$  results for  $I_{AREFX}$ .
- 3) For the details of the mapping for a VADC group to pin  $V_{AREFX}$  please see the User's Manual.
- 4) The broken wire detection delay against  $V_{AGND}$  is measured in numbers of consecutive precharge cycles at a conversion rate higher than 1 conversion per 500 ms.
- 5) The broken wire detection delay against  $V_{AREF}$  is measured in numbers of consecutive precharge cycles at a conversion rate higher than 1 conversion per 10 ms. This function is influenced by leakage current, in particular at high temperature.
- 6) Resulting worst case combined error is arithmetic combination of TUE and  $EN_{RMS}$ .
- 7) This parameter is valid for soldered devices and requires careful analog board design.
- 8) Value is defined for one sigma Gauss distribution.
- 9) In order to avoid an additional error due to incomplete sampling, the sampling time shall be set greater than  $5 \cdot R_{CSD} \cdot C_{AINS}$ .
- 10) The pull-down resistor  $R_{PDD}$  is connected between the input pad and the analog multiplexer. The input pad itself adds another 200-Ohm series resistance, when measuring through the pin.
- 11) CSD: Converter Self Diagnostics, for details please consult the User's Manual.
- 12) Note, that in case CSD voltage is chosen to nom. 1/3 or 2/3 of  $V_{AREF}$  voltage, the reference voltage is loaded with a current of max.  $V_{AREF} / 45$  kOhm.

The following VADC parameter are valid for  $V_{DDM} = 2.97 V$  to  $3.63 V$ .

**Table 3-28 VADC\_33V**

Parameter	Symbol	Values			Unit	Note / Test Condition
		Min.	Typ.	Max.		
Analog reference voltage <sup>1)</sup>	$V_{AREF}$ SR	$V_{AGND} + 1.0$	-	$V_{DDM} + 0.05$	V	
Analog reference ground	$V_{AGND}$ SR	$V_{SSM} - 0.05$	-	$V_{SSM} + 0.05$	V	
Analog input voltage range	$V_{AIN}$ SR	$V_{AGND}$	-	$V_{AREF}$	V	
Converter reference clock	$f_{ADCI}$ SR	2	-	20	MHz	

**Electrical Specification VADC Parameters**
**Table 3-28 VADC\_33V (cont'd)**

Parameter	Symbol	Values			Unit	Note / Test Condition
		Min.	Typ.	Max.		
Charge consumption per conversion <sup>2) 3)</sup>	$Q_{CONV}$ CC	-	35	50	pC	$V_{AIN} = 3.3$ V, charge consumed from reference pin, precharging disabled
		-	8	17	pC	$V_{AIN} = 3.3$ V, charge consumed from reference pin, precharging enabled
Conversion time for 12-bit result	$t_{C12}$ CC	-	$(16 + \text{STC}) \times t_{ADCI} + 2 \times t_{VADC}$	-		Includes sample time and post calibration
Conversion time for 10-bit result	$t_{C10}$ CC	-	$(14 + \text{STC}) \times t_{ADCI} + 2 \times t_{VADC}$	-		Includes sample time
Conversion time for 8-bit result	$t_{C8}$ CC	-	$(12 + \text{STC}) \times t_{ADCI} + 2 \times t_{VADC}$	-		Includes sample time
Conversion time for fast compare mode	$t_{CF}$ CC	-	$(4 + \text{STC}) \times t_{ADCI} + 2 \times t_{VADC}$	-		Includes sample time
Broken wire detection delay against $V_{AGND}$ <sup>4)</sup>	$t_{BWG}$ CC	-	-	120	cycles	Result below 10%
Broken wire detection delay against $V_{AREF}$ <sup>5)</sup>	$t_{BWR}$ CC	-	-	60	cycles	Result above 80%
Input leakage at analog inputs	$I_{OZ1}$ CC	-350	-	350	nA	Analog Inputs overlaid with class LP pads or pull down diagnostics
		-150	-	150	nA	else
Total Unadjusted Error <sup>1)</sup>	TUE CC	-12 <sup>6)</sup>	-	12 <sup>6)</sup>	LSB	12-bit Resolution; $T_J > 150$ °C
		-6 <sup>6)</sup>	-	6 <sup>6)</sup>	LSB	12-bit Resolution; $T_J \leq 150$ °C
INL Error	$EA_{INL}$ CC	-12	-	12	LSB	12-bit Resolution; $T_J > 150$ °C
		-5	-	5	LSB	12-bit Resolution; $T_J \leq 150$ °C
Gain Error <sup>1)</sup>	$EA_{GAIN}$ CC	-6	-	6	LSB	12-bit Resolution; $T_J > 150$ °C
		-5.5	-	5.5	LSB	12-bit Resolution; $T_J \leq 150$ °C

## Electrical Specification VADC Parameters

Table 3-28 VADC\_33V (cont'd)

Parameter	Symbol	Values			Unit	Note / Test Condition
		Min.	Typ.	Max.		
DNL error <sup>1)</sup>	$EA_{DNL}$ CC	-4	-	4	LSB	12-bit resolution
Offset Error <sup>1)</sup>	$EA_{OFF}$ CC	-6	-	6	LSB	12-bit Resolution; $T_J > 150^\circ\text{C}$
		-5	-	5	LSB	12-bit Resolution; $T_J \leq 150^\circ\text{C}$
Total capacitance of an analog input	$C_{AINT}$ CC	-	-	30	pF	
Switched capacitance of an analog input	$C_{AINS}$ CC	2	4	7	pF	
Resistance of the analog input path	$R_{AIN}$ CC	-	-	4.5	kOhm	
Switched capacitance of a reference input	$C_{AREFS}$ CC	-	-	30	pF	
RMS Noise <sup>7)</sup>	$EN_{RMS}$ CC	-	-	1.7 <sup>6)8)</sup>	LSB	
Positive reference $V_{AREFX}$ pin leakage	$I_{OZ2}$ CC	-6	-	6	$\mu\text{A}$	$V_{AREFX} = V_{AREF2}$ ; $V_{AREF} > V_{DDM}V$ ; $T_J > 150^\circ\text{C}$
		-3.5	-	3.5	$\mu\text{A}$	$V_{AREFX} = V_{AREF2}$ ; $V_{AREF} > V_{DDM}V$ ; $T_J \leq 150^\circ\text{C}$
		-2	-	2.5	$\mu\text{A}$	$V_{AREFX} = V_{AREF2}$ ; $V_{AREF} \leq V_{DDM}V$ ; $T_J > 150^\circ\text{C}$
		-1	-	1	$\mu\text{A}$	$V_{AREFX} = V_{AREF2}$ ; $V_{AREF} \leq V_{DDM}V$ ; $T_J \leq 150^\circ\text{C}$
Negative reference $V_{AGNDx}$ pin leakage	$I_{OZ3}$ CC	-12	-	12	$\mu\text{A}$	$V_{AGNDx} = V_{AGND2}$ ; $V_{AGND} < V_{SSM}V$ ; $T_J > 150^\circ\text{C}$
		-6.5	-	6.5	$\mu\text{A}$	$V_{AGNDx} = V_{AGND2}$ ; $V_{AGND} < V_{SSM}V$ ; $T_J \leq 150^\circ\text{C}$
		-2.2	-	2	$\mu\text{A}$	$V_{AGNDx} = V_{AGND2}$ ; $V_{AREF} \leq V_{DDM}V$ ; $T_J > 150^\circ\text{C}$
		-1	-	1	$\mu\text{A}$	$V_{AGNDx} = V_{AGND2}$ ; $V_{AREF} \leq V_{DDM}V$ ; $T_J \leq 150^\circ\text{C}$
Resistance of the reference input path	$R_{AREF}$ CC	-	-	3	kOhm	
CSD resistance <sup>9)</sup>	$R_{CSD}$ CC	-	-	28	kOhm	

Table 3-28 VADC\_33V (cont'd)

Parameter	Symbol	Values			Unit	Note / Test Condition
		Min.	Typ.	Max.		
Resistance of the multiplexer diagnostics pull-down device	$R_{MDD}$ CC	$25 + 3 \cdot V_{IN}$	-	$40 + 12 \cdot V_{IN}$	kOhm	$0 \text{ V} \leq V_{IN} \leq 1.667 \text{ V}$
		$0 + 18 \cdot V_{IN}$	-	$0 + 18 \cdot V_{IN}$	kOhm	$1.667 \text{ V} \leq V_{IN} \leq V_{DDM}$
Resistance of the multiplexer diagnostics pull-up device	$R_{MDU}$ CC	$60 - 12 \cdot V_{IN}$	-	$120 - 30 \cdot V_{IN}$	kOhm	$0 \text{ V} \leq V_{IN} \leq 1.667 \text{ V}$
		$55 - 9 \cdot V_{IN}$	-	$95 - 15 \cdot V_{IN}$	kOhm	$1.667 \text{ V} \leq V_{IN} \leq V_{DDM}$
Resistance of the pull-down test device <sup>10)</sup>	$R_{PDD}$ CC	-	-	0.9	kOhm	
CSD voltage accuracy <sup>11) 12)</sup>	$dVCSD$ CC	-	-	10	%	
Wakeup time	$t_{WU}$ CC	-	-	12	$\mu\text{s}$	

- 1) If the reference voltage is reduced by the factor  $k$  ( $k < 1$ ), TUE, DNL, INL, Gain, and Offset errors increase also by the factor  $1/k$ .  $V_{AREF}$  must be decoupled with an external capacitor.
- 2) For  $QCONV = X \text{ pC}$  and a conversion time of  $1 \mu\text{s}$  a rms value of  $X \mu\text{A}$  results for  $I_{AREFX}$ .
- 3) For the details of the mapping for a VADC group to pin  $V_{AREFX}$  please see the User's Manual.
- 4) The broken wire detection delay against  $V_{AGND}$  is measured in numbers of consecutive precharge cycles at a conversion rate higher than 1 conversion per 500 ms.
- 5) The broken wire detection delay against  $V_{AREF}$  is measured in numbers of consecutive precharge cycles at a conversion rate higher than 1 conversion per 10 ms. This function is influenced by leakage current, in particular at high temperature.
- 6) Resulting worst case combined error is arithmetic combination of TUE and  $EN_{RMS}$ .
- 7) This parameter is valid for soldered devices and requires careful analog board design.
- 8) Value is defined for one sigma Gauss distribution.
- 9) In order to avoid an additional error due to incomplete sampling, the sampling time shall be set greater than  $5 \cdot R_{CSD} \cdot C_{AINS}$ .
- 10) The pull-down resistor  $R_{PDD}$  is connected between the input pad and the analog multiplexer. The input pad itself adds another 200-Ohm series resistance, when measuring through the pin.
- 11) CSD: Converter Self Diagnostics, for details please consult the User's Manual.
- 12) Note, that in case CSD voltage is chosen to nom. 1/3 or 2/3 of  $V_{AREF}$  voltage, the reference voltage is loaded with a current of max.  $V_{AREF} / 45 \text{ kOhm}$ .

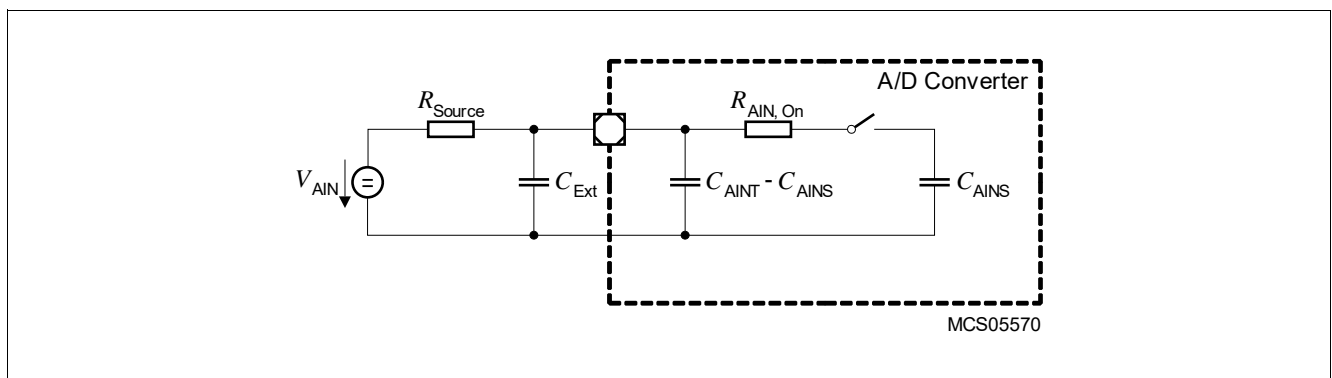

Figure 3-1 Equivalent Circuitry for Analog Inputs

### 3.10 DSADC Parameters

The following DSADC parameter are valid for  $V_{DDM} = 4.5 \text{ V}$  to  $5.5 \text{ V}$ .

Table 3-29 DSADC

Parameter	Symbol	Values			Unit	Note / Test Condition
		Min.	Typ.	Max.		
Analog input voltage range <sup>1)</sup>	$V_{DSIN}$ SR	0	-	5	V	single ended
		0	-	10	V	differential; $V_{DSxP} - V_{DSxN}$
Reference load current	$I_{REF}$ SR	-	4.5	6.3	$\mu\text{A}$	per twin-modulator (1 or 2 channels)
Modulator clock frequency <sup>2)</sup>	$f_{MOD}$ SR	10	-	20	MHz	
Gain error	$ED_{GAIN}$ CC	-1	-	1 <sup>3)</sup>	%	Calibrated once
		-3.5 <sup>4)</sup>	-	3.5 <sup>4)</sup>	%	Uncalibrated
		-0.2	-	0.2 <sup>5)</sup>	%	calibrated; GAIN = 1; MODCFG.INCFGx=01
DC offset error	$ED_{OFF}$ CC	-5	-	5 <sup>5)</sup>	mV	calibrated
		-50	-	50	mV	calibrated once
		-100 <sup>4)</sup>	0 <sup>4)</sup>	100 <sup>4)</sup>	mV	gain = 1; uncalibrated
Common Mode Rejection Ratio	$ED_{CM}$ CC	200	500	-		
Input impedance <sup>6)</sup>	$R_{DAIN}$ CC	100	130	170	kOhm	Exact value ( $\pm 1\%$ ) available in UCB
Signal-Noise Ratio <sup>7) 8) 9) 10)</sup>	SNR CC	80	-	-	dB	$f_{PB} = 30 \text{ kHz}$ ; $V_{DDM} = \pm 5\%$ ; $f_{MOD} = 20 \text{ MHz}$ ; GAIN = 1
		78	-	-	dB	$f_{PB} = 50 \text{ kHz}$ ; $V_{DDM} = \pm 5\%$ ; $f_{MOD} = 20 \text{ MHz}$ ; GAIN = 1
		70	-	-	dB	$f_{PB} = 100 \text{ kHz}$ ; $V_{DDM} = \pm 10\%$ ; $f_{MOD} = 20 \text{ MHz}$ ; GAIN = 1
		74	-	-	dB	$f_{PB} = 100 \text{ kHz}$ ; $V_{DDM} = \pm 5\%$ ; $f_{MOD} = 20 \text{ MHz}$ ; GAIN = 1
		76	-	-	dB	$f_{PB} = 30 \text{ kHz}$ ; $V_{DDM} = \pm 10\%$ ; $f_{MOD} = 20 \text{ MHz}$ ; GAIN = 1
		74	-	-	dB	$f_{PB} = 50 \text{ kHz}$ ; $V_{DDM} = \pm 10\%$ ; $f_{MOD} = 20 \text{ MHz}$ ; GAIN = 1
Pass band	$f_{PB}$ CC	10 <sup>11)</sup>	-	100	kHz	Output data rate $f_D = f_{PB} * 3$
Pass band ripple <sup>8)</sup>	$df_{PB}$ CC	-1	-	1	%	
Output sampling rate	$f_D$ CC	30	-	330	kHz	

**Table 3-29 DSADC (cont'd)**

Parameter	Symbol	Values			Unit	Note / Test Condition
		Min.	Typ.	Max.		
DC compensation factor	<i>DCF</i> CC	-3	-	-	dB	$10^{-5} f_D$
Positive reference $V_{AREF1}$ pin leakage	$I_{OZ5}$ CC	-2	-	2	$\mu$ A	all ADCs disabled
Negative reference $V_{AGND1}$ pin leakage	$I_{OZ6}$ CC	-2	-	2	$\mu$ A	all ADCs disabled
Stop band attenuation <sup>8)</sup>	<i>SBA</i> CC	40	-	-	dB	$0.5 \dots 1 f_D$
		45	-	-	dB	$1 \dots 1.5 f_D$
		50	-	-	dB	$1.5 \dots 2 f_D$
		55	-	-	dB	$2 \dots 2.5 f_D$
		60	-	-	dB	$2.5 \dots \text{OSR}/2 f_D$
Reference ground voltage	$V_{AGND}$ SR	$V_{SSM} - 0.05$	-	$V_{SSM} + 0.05$	V	
Positive reference voltage	$V_{AREF}$ SR	$V_{DDMnom} * 0.9$	-	$V_{DDM} + 0.05$	V	
Common mode voltage accuracy	$dV_{CM}$ CC	-100	-	100	mV	from selected voltage
Common mode hold voltage deviation <sup>12)</sup>	$dV_{CMH}$ CC	-200	-	200	mV	From common mode voltage
Analog filter settling time	$t_{AFSET}$ CC	-	2	4	$\mu$ s	If enabled
Modulator recovery time	$t_{MREC}$ CC	-	3.5	5.5	$\mu$ s	After leaving overdrive state
Modulator settling time <sup>13)</sup>	$t_{MSET}$ CC	-	1	-	$\mu$ s	After switching on, voltage regulator already running
Spurious Free Dynamic Range <sup>7)14)</sup>	SFDR CC	60	-	-	dB	$V_{CM} = 2.2$ V, DC coupled; $V_{DDM} = \pm 10\%$

- 1) The maximum input range for symmetrical signals (e.g. AC-coupled inputs) depends on the selected internal/external common mode voltage. In this case the Amplitude is limited to  $V_{CM} * 2$ .
- 2) All modulators must run on the same frequency.
- 3) The calibration sequence must be executed once after an Application Reset
- 4) The total DC error for the uncalibrated case can be calculated by the geometric addition of  $ED_{GAIN}$  and  $ED_{OFF}$
- 5) Recalibration needed in case of a temperature change > 20°C
- 6) The variation of the impedance between different channels is < 1.5%.
- 7) Derating factors:  
 -2 dB in standard-performance mode.  
 -3 dB for  $CMV = 10_B$ , i.e.  $V_{CM} = (V_{AREF} \pm 2\%) / 2.0$ .
- 8) CIC3, FIR0, FIR1 filters enabled.
- 9) Single-ended mode reduces the SNR by 6 dB if the unused input is grounded, by 3 dB if the unused input connects to  $V_{CM}$  (GAIN = 2).
- 10) The defined limits are only valid if the following condition is not applicable:  $T_J > 150^\circ\text{C}$  and  $V_{VAREF} > V_{DDM}$ .
- 11) 10 kHz only reachable with 10 MHz modulator clock frequency.
- 12) Voltage  $V_{CM}$  is proportional to  $V_{AREF}$ , voltage  $V_{CMH}$  is proportional to  $V_{DDM}$ .
- 13) The modulator needs to settle after being switched on and after leaving the overdrive state.
- 14)  $SFDR = 20 * \log(INL / 2^N)$ ; N = amount of bits

**Electrical Specification DSADC Parameters**

The following DSADC parameter are valid for  $V_{DDM} = 2.97\text{ V}$  to  $3.63\text{ V}$ .

**Table 3-30 DSADC\_33V**

Parameter	Symbol	Values			Unit	Note / Test Condition
		Min.	Typ.	Max.		
Analog input voltage range <sup>1)</sup>	$V_{DSIN}$ SR	0	-	3.3	V	single ended
		0	-	6.6	V	differential; $V_{DSxP} - V_{DSxN}$
Reference load current	$I_{REF}$ SR	-	4.5	5.8	$\mu\text{A}$	per twin-modulator (1 or 2 channels)
Modulator clock frequency <sup>2)</sup>	$f_{MOD}$ SR	10	-	20	MHz	
Gain error	$ED_{GAIN}$ CC	-1.5	-	1.5 <sup>3)</sup>	%	Calibrated once
		-10 <sup>4)</sup>	-	10 <sup>4)</sup>	%	Uncalibrated
		-0.3	-	0.3 <sup>5)</sup>	%	calibrated; GAIN = 1; MODCFG.INCFGx=01
DC offset error	$ED_{OFF}$ CC	-5	-	5 <sup>5)</sup>	mV	calibrated
		-50	-	50	mV	calibrated once
		-100 <sup>4)</sup>	-	100 <sup>4)</sup>	mV	gain = 1; uncalibrated
		-	0 <sup>4)</sup>	-	mV	gain = 1; uncalibrated; uncalibrated
Common Mode Rejection Ratio	$ED_{CM}$ CC	200	500	-		
Input impedance <sup>6)</sup>	$R_{DAIN}$ CC	100	130	170	kOhm	Exact value ( $\pm 1\%$ ) available in UCB
Signal-Noise Ratio <sup>7) 8) 9) 10)</sup>	SNR CC	45	63	-	dB	$f_{PB} = 100\text{kHz}$ ; $V_{DDM} = \pm 10\%$ ; $f_{MOD} = 20\text{ MHz}$ ; GAIN = 1
		60	69	-	dB	$f_{PB} = 100\text{kHz}$ ; $V_{DDM} = \pm 5\%$ ; $f_{MOD} = 20\text{ MHz}$ ; GAIN = 1
		60	68	-	dB	$f_{PB} = 30\text{kHz}$ ; $V_{DDM} = \pm 10\%$ ; $f_{MOD} = 20\text{ MHz}$ ; GAIN = 1
		69	74	-	dB	$f_{PB} = 30\text{kHz}$ ; $V_{DDM} = \pm 5\%$ ; $f_{MOD} = 20\text{ MHz}$ ; GAIN = 1
		55	66	-	dB	$f_{PB} = 50\text{kHz}$ ; $V_{DDM} = \pm 10\%$ ; $f_{MOD} = 20\text{ MHz}$ ; GAIN = 1
		65	72	-	dB	$f_{PB} = 50\text{kHz}$ ; $V_{DDM} = \pm 5\%$ ; $f_{MOD} = 20\text{ MHz}$ ; GAIN = 1
Pass band	$f_{PB}$ CC	10 <sup>11)</sup>	-	100	kHz	Output data rate $f_D = f_{PB} * 3$
Pass band ripple <sup>8)</sup>	$df_{PB}$ CC	-1	-	1	%	

**Table 3-30 DSADC\_33V (cont'd)**

Parameter	Symbol	Values			Unit	Note / Test Condition
		Min.	Typ.	Max.		
Output sampling rate	$f_D$ CC	30	-	330	kHz	
DC compensation factor	$DCF$ CC	-3	-	-	dB	$10^{-5} f_D$
Positive reference $V_{AREF1}$ pin leakage	$I_{OZ5}$ CC	-2	-	2	$\mu$ A	
Negative reference $V_{AGND1}$ pin leakage	$I_{OZ6}$ CC	-2	-	2	$\mu$ A	
Stop band attenuation <sup>8)</sup>	$SBA$ CC	40	-	-	dB	$0.5 \dots 1 f_D$
		45	-	-	dB	$1 \dots 1.5 f_D$
		50	-	-	dB	$1.5 \dots 2 f_D$
		55	-	-	dB	$2 \dots 2.5 f_D$
		60	-	-	dB	$2.5 \dots OSR/2 f_D$
Reference ground voltage	$V_{AGND}$ SR	$V_{SSM} - 0.05$	-	$V_{SSM} + 0.05$	V	
Positive reference voltage	$V_{AREF}$ SR	$V_{DDMnom} * 0.9$	-	$V_{DDM} + 0.05$	V	
Common mode voltage accuracy	$dV_{CM}$ CC	-100	-	100	mV	from selected voltage
Common mode hold voltage deviation <sup>12)</sup>	$dV_{CMH}$ CC	-200	-	200	mV	From common mode voltage
Analog filter settling time	$t_{AFSET}$ CC	-	2	4	$\mu$ s	If enabled
Modulator recovery time	$t_{MREC}$ CC	-	3.5	-	$\mu$ s	After leaving overdrive state
Modulator settling time <sup>13)</sup>	$t_{MSET}$ CC	-	1	-	$\mu$ s	After switching on, voltage regulator already running
Spurious Free Dynamic Range <sup>7)14)</sup>	SFDR CC	52	-	-	dB	$V_{CM} = 2.2$ V, DC coupled; $V_{DDM} = \pm 10\%$
		60	-	-	dB	$V_{CM} = 2.2$ V, DC coupled; $V_{DDM} = \pm 5\%$

- 1) The maximum input range for symmetrical signals (e.g. AC-coupled inputs) depends on the selected internal/external common mode voltage. In this case the Amplitude is limited to  $V_{CM} * 2$ .
- 2) All modulators must run on the same frequency.
- 3) The calibration sequence must be executed once after an Application Reset
- 4) The total DC error for the uncalibrated case can be calculated by the geometric addition of  $ED_{GAIN}$  and  $ED_{OFF}$
- 5) Recalibration needed in case of a temperature change  $> 20^\circ\text{C}$ .
- 6) The variation of the impedance between different channels is  $< 1.5\%$ .
- 7) Derating factors:  
-2 dB in standard-performance mode.  
-3 dB for  $CMV = 10_B$ , i.e.  $V_{CM} = (V_{AREF} \pm 2\%) / 2.0$ .
- 8) CIC3, FIR0, FIR1 filters enabled.
- 9) Single-ended mode reduces the SNR by 6 dB if the unused input is grounded, by 3 dB if the unused input connects to  $V_{CM}$  (GAIN = 2).
- 10) The defined limits are only valid if the following condition is not applicable:  $T_J > 150^\circ\text{C}$  and  $V_{VAREF} > V_{DDM}$ .

- 11) 10 kHz bandwidth only with 10Mhz modulator clock frequency reachable
- 12) Voltage  $V_{CM}$  is proportional to  $V_{AREF}$ , voltage  $V_{CMH}$  is proportional to  $V_{DDM}$ .
- 13) The modulator needs to settle after being switched on and after leaving the overdrive state.
- 14)  $SFDR = 20 * \log(INL / 2^N)$ ; N = amount of bits

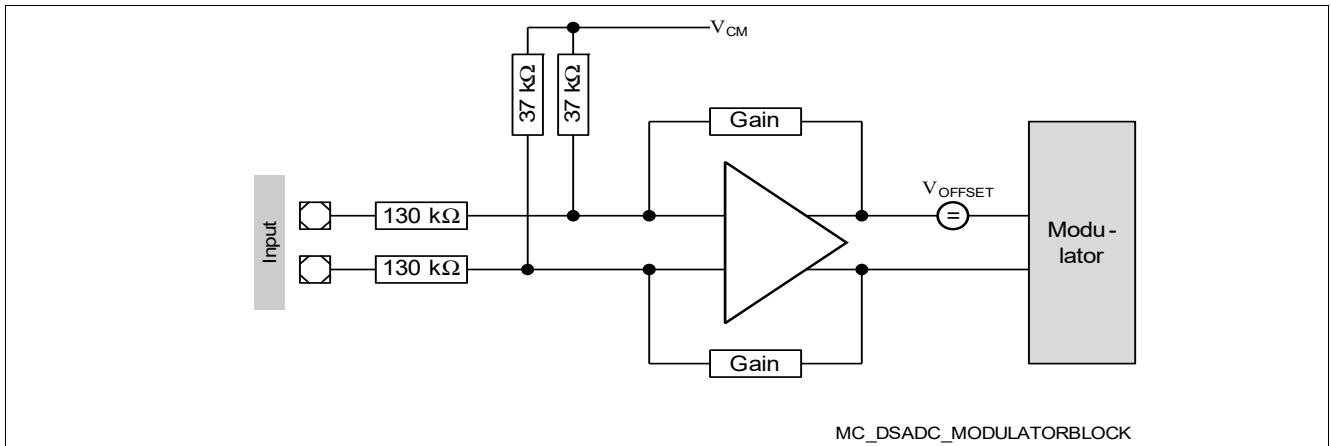

Figure 3-2 DSADC Analog Inputs

### 3.11 MHz Oscillator

OSC\_XTAL is used as accurate and exact clock source. OSC\_XTAL supports 8 MHz to 40 MHz crystals external outside of the device. Support of ceramic resonators is also provided.

**Table 3-31 OSC\_XTAL**

Parameter	Symbol	Values			Unit	Note / Test Condition
		Min.	Typ.	Max.		
Input current at XTAL1	$I_{IX1}$ CC	-25	-	25	$\mu\text{A}$	$V_{IN} > 0\text{V}$ ; $V_{IN} < V_{DDP3}\text{V}$
Oscillator frequency	$f_{OSC}$ SR	4	-	40	MHz	Direct Input Mode selected
		8	-	40	MHz	External Crystal Mode selected
Oscillator start-up time <sup>1)</sup>	$t_{OSCS}$ CC	-	-	5 <sup>2)</sup>	ms	
Input high voltage at XTAL1	$V_{IHBX}$ SR	0.8	-	$V_{DDP3} + 0.5$	V	If shaper is bypassed
Input low voltage at XTAL1	$V_{ILBX}$ SR	-0.5	-	0.4	V	If shaper is bypassed
Input voltage at XTAL1	$V_{IX}$ SR	-0.5	-	$V_{DDP3} + 0.5$	V	If shaper is not bypassed
Input amplitude (peak to peak) at XTAL1	$V_{PPX}$ SR	0.3 * $V_{DDP3}$	-	$V_{DDP3} + 1.0$	V	If shaper is not bypassed; $f_{OSC} > 25\text{MHz}$
		0.4 * $V_{DDP3}$	-	$V_{DDP3} + 1.0$	V	If shaper is not bypassed; $f_{OSC} \leq 25\text{MHz}$
Internal load capacitor	$C_{L0}$ CC	2	2.35	2.7	pF	
Internal load capacitor	$C_{L1}$ CC	2	2.35	2.7	pF	
Internal load capacitor	$C_{L2}$ CC	3	3.5	4	pF	
Internal load capacitor	$C_{L3}$ CC	5.1	5.9	6.6	pF	

1)  $t_{OSCS}$  is defined from the moment when  $V_{DDP3} = 3.13\text{V}$  until the oscillations reach an amplitude at XTAL1 of  $0.3 * V_{DDP3}$ . The external oscillator circuitry must be optimized by the customer and checked for negative resistance as recommended and specified by crystal suppliers.

2) This value depends on the frequency of the used external crystal. For faster crystal frequencies this value decrease.

*Note: It is strongly recommended to measure the oscillation allowance (negative resistance) in the final target system (layout) to determine the optimal parameters for the oscillator operation. Please refer to the limits specified by the crystal or ceramic resonator supplier.*

### 3.12 Back-up Clock

The back-up clock provides an alternative clock source.

**Table 3-32 Back-up Clock**

Parameter	Symbol	Values			Unit	Note / Test Condition
		Min.	Typ.	Max.		
Back-up clock before trimming	$f_{\text{BACKUT}}$ CC	75	100	125	MHz	$V_{\text{EXT}} \geq 2.97\text{V}$
Back-up clock after trimming	$f_{\text{BACKT}}$ CC	97.5	100	102.5	MHz	$V_{\text{EXT}} \geq 2.97\text{V}$

**3.13 Temperature Sensor**
**Table 3-33 DTS**

Parameter	Symbol	Values			Unit	Note / Test Condition
		Min.	Typ.	Max.		
Measurement time	$t_M$ CC	-	-	100	µs	
Calibration reference accuracy	$T_{CALACC}$ CC	-1	-	1	°C	calibration points @ $T_J = -40^\circ\text{C}$ and $T_J = 127^\circ\text{C}$
Non-linearity accuracy over temperature range	$T_{NL}$ CC	-2	-	2	°C	
Temperature sensor range	$T_{SR}$ SR	-40	-	170	°C	
Start-up time after resets inactive	$t_{TSST}$ SR	-	-	20	µs	

The following formula calculates the temperature measured by the DTS in [°C] from the RESULT bit field of the DTSSTAT register.

(3.1)

$$T_J = \frac{DTSSTATRESULT - (607)}{2, 13}$$

### 3.14 Power Supply Current

The total power supply current defined below consists of leakage and switching component.

Application relevant values are typically lower than those given in the following table and depend on the customer's system operating conditions (e.g. thermal connection or used application configurations).

The operating conditions for the parameters in the following table are:

The real (realistic) power pattern defines the following conditions:

- $T_J = 150\text{ °C}$
- $f_{SRI} = f_{MAX} = f_{CPU0} = 200\text{ MHz}$
- $f_{SPB} = f_{STM} = f_{GTM} = f_{BAUD1} = f_{BAUD2} = f_{ASCLIN} = 40\text{ MHz}$
- $V_{DD} = 1.326\text{ V}$
- $V_{DDP3} = 3.366\text{ V}$
- $V_{EXT/FLEX} = V_{DDM} = 5.1\text{ V}$
- all cores are active including one lockstep core
- the following peripherals are inactive: HSM, HSCT, Ethernet, PSI5, I2C, FCE, MTU, and 50% of the DSADC channels

The max power pattern defines the following conditions:

- $T_J = 150\text{ °C}$
- $f_{SRI} = f_{MAX} = f_{CPU0} = 200\text{ MHz}$
- $f_{SPB} = f_{STM} = f_{GTM} = f_{BAUD1} = f_{BAUD2} = f_{ASCLIN} = 100\text{ MHz}$
- $V_{DD} = 1.43\text{ V}$
- $V_{DDP3} = 3.63\text{ V}$
- $V_{EXT/FLEX} = V_{DDM} = 5.5\text{ V}$
- all cores and lockstep cores are active
- all peripherals are active

**Table 3-34 Power Supply**

Parameter	Symbol	Values			Unit	Note / Test Condition
		Min.	Typ.	Max.		
$\Sigma$ Sum of $I_{DD}$ 1.3 V core and peripheral supply currents	$I_{DD}$ CC	-	-	550	mA	max power pattern
		-	-	350	mA	real power pattern
$I_{DD}$ core current during active power-on reset (PORST held low)	$I_{DDPORST}$ CC	-	-	80	mA	$T_J=125\text{ °C}$
		-	-	160	mA	$T_J=150\text{ °C}$
		-	-	215	mA	$T_J=165\text{ °C}$
$I_{DD}$ core current of CPU0 lockstep core active	$I_{DDC01}$ CC	-	-	36	mA	real power pattern
$I_{DD}$ core current of CPU1 main core with CPU1 lockstep core inactive	$I_{DDC10}$ CC	-	-	43	mA	real power pattern
$I_{DD}$ core current of CPU1 main core with lockstep core active	$I_{DDC11}$ CC	-	-	$I_{DDC10} + 36$	mA	real power pattern
$I_{DD}$ core current of CPU2 main core	$I_{DDC20}$ CC	-	-	37	mA	real power pattern

## Electrical Specification Power Supply Current

Table 3-34 Power Supply (cont'd)

Parameter	Symbol	Values			Unit	Note / Test Condition
		Min.	Typ.	Max.		
$I_{DD}$ core current added by HSM	$I_{DDHSM}$ CC	-	-	20	mA	HSM running at 100MHz.
$\Sigma$ Sum of 3.3 V supply currents without pad activity	$I_{DDx3RAIL}$ CC	-	-	57	mA	real power pattern
$I_{DDFL3}$ Flash memory current	$I_{DDFL3}$ CC	-	-	42 <sup>1)</sup>	mA	flash read current
		-	-	42 <sup>2)</sup>	mA	flash read current while programming Dflash
$I_{DDP3}$ supply current without pad activity	$I_{DDP3}$ CC	-	-	15 <sup>1)</sup>	mA	real power pattern; incl. OSC current & flash read current
		-	-	37 <sup>3)</sup>	mA	incl. OSC current and flash 3.3V programming current when using external 5V supply
		-	-	39 <sup>2)</sup>	mA	incl. OSC current and flash programming current at 3.3V
$I_{DDP3}$ supply current for LVDSH pads in LVDS mode	$I_{DDP3LVDSH}$ CC	-	-	16	mA	
$\Sigma$ Sum of external and ADC supply currents (incl. $I_{EXTFLEX}+I_{DDM}+I_{EXTLVDSM}$ )	$I_{EXTRAIL}$ CC	-	-	62	mA	real power pattern
Sum of $I_{EXT}$ and $I_{FLEX}$ supply current without pad activity	$I_{EXT/FLEX}$ CC	-	-	4	mA	real power pattern; PORST output inactive.
$I_{EXT}$ supply current for LVDSM pads in LVDS mode	$I_{EXTLVDSM}$ CC	-	-	14 <sup>4)</sup>	mA	real power pattern

**Electrical Specification Power Supply Current**
**Table 3-34 Power Supply (cont'd)**

Parameter	Symbol	Values			Unit	Note / Test Condition
		Min.	Typ.	Max.		
$I_{DDM}$ supply current	$I_{DDM}$ CC	-	-	44	mA	real power pattern; sum of currents of DSADC and VADC modules
		-	-	30	mA	current for DSADC module only; 50% DSADC channels active.
		-	-	14	mA	real pattern; current for VADC only
		-	-	59 <sup>5)</sup>	mA	max power pattern; All DSADC channels active 100% time.
		-	-	17 <sup>6)</sup>	mA	max power pattern; All VADC converters are active 100% time
$\Sigma$ Sum of all currents (incl. $I_{EXTRAIL} + I_{DDX3RAIL} + I_{DD}$ )	$I_{DDTOT}$ CC	-	-	469	mA	real power pattern
$\Sigma$ Sum of all currents with DC-DC EVR13 regulator active <sup>7)</sup>	$I_{DDTOTDC3}$ CC	-	-	302	mA	real power pattern; $V_{EXT} = 3.3V$
$\Sigma$ Sum of all currents with DC-DC EVR13 regulator active <sup>7)</sup>	$I_{DDTOTDC5}$ CC	-	-	240	mA	real power pattern; $V_{EXT} = 5V$
$\Sigma$ Sum of all currents (STANDBY mode)	$I_{EVRSB}$ CC	-	-	150 <sup>8)</sup>	$\mu A$	Standby RAM is active. Power to remaining domains switched off. $T_J = 25^\circ C$ ; $V_{EVRSB} = 5V$
$\Sigma$ Sum of all currents (SLEEP mode)	$I_{SLEEP}$ CC	-	-	15	mA	All CPUs in idle, All peripherals in sleep, $f_{SRI/SPB} = 1 MHz$ via LPDIV divider; $T_J = 25^\circ C$
Maximum power dissipation	PD CC	-	-	1480	mW	max power pattern
		-	-	1014	mW	real power pattern

- 1) Realistic Pflash read pattern with 70% Pflash bandwidth utilization and a code mix of 50% 0s and 50% 1s. A common decoupling capacitor of at least 100nF for ( $V_{DDFL3} + V_{DDP3}$ ) is used. Dflash read current is also included. Flash read current is predominantly drawn from  $V_{DDFL3}$  pin and a minor part drawn from the neighbouring  $V_{DDP3}$  pin.
- 2) Continuous Dflash programming in burst mode with 3.3 V supply and realistic Pflash read access in parallel. Erase currents of the corresponding flash modules are less than the respective programming currents at  $V_{DDP3}$  pin. Programming and erasing flash may generate transient current spikes of up to x mA for maximum x us which is handled by the decoupling and buffer capacitors. This parameter is relevant for external power supply dimensioning and not for thermal considerations.
- 3) In addition to the current specified, upto 4 mA is additionally drawn at  $V_{EXT}$  supply in burst programming mode with 5V external supply. Erase currents of the corresponding flash modules are less than the respective programming currents at  $V_{DDP3}$  supply. This parameter is relevant for external power supply dimensioning and not for thermal considerations.

- 4) The current consumption is for 2 pairs of LVDSM differential pads (8 pins). A single pair of LVDSM differential pads (4 pins) consumes 7 mA.
- 5) The current consumption is for 6 DS channels with standard performance (MCFG=11b). A single DS channel instance consumes 6-8 mA.
- 6) A single converter instance of VADC unit consumes 2 mA.
- 7) The total current drawn from external regulator is estimated with 72% EVR13 SMPS regulator Efficiency.  $I_{DDTOTDC}$  is calculated from  $I_{DDTOT}$  using the scaled core current  $[(I_{DD} \times V_{DD}) / (V_{in} \times \text{Efficiency})]$  and constitutes all other rail currents and  $I_{DDM}$ .
- 8) Current at  $V_{EVR_{RSB}}$  supply pin during normal RUN mode is less than 5 mA at  $T_j = 150$  degC. The transition between RUN mode to STANDBY mode has a duration of less than 100us during which the current is higher but is less than 8 mA at  $T_j = 150$  degC. Once STANDBY mode is entered with only Standby RAM active the current is less than 5mA at  $T_j = 150$  degC. It is recommended to have atleast 100 nF decoupling capacitor at this pin.

### 3.14.1 Calculating the 1.3 V Current Consumption

The current consumption of the 1.3 V rail compose out of two parts:

- Static current consumption
- Dynamic current consumption

The static current consumption is related to the device temperature  $T_j$  and the dynamic current consumption depends of the configured clocking frequencies and the software application executed. These two parts needs to be added in order to get the rail current consumption.

(3.2)

$$I_0 = 1,135 \left[ \frac{\text{mA}}{\text{C}} \right] \times e^{0,02689 \times T_j[\text{C}]}$$

(3.3)

$$I_0 = 3,264 \left[ \frac{\text{mA}}{\text{C}} \right] \times e^{0,0259 \times T_j[\text{C}]}$$

Function 2 defines the typical static current consumption and Function 3 defines the maximum static current consumption. Both functions are valid for  $V_{DD} = 1.326$  V.

### 3.15 Power-up and Power-down

#### 3.15.1 External Supply Mode

5 V & 1.3 V supplies are externally supplied. 3.3V is generated internally by EVR33.

- External supplies VEXT and VDD may ramp-up or ramp-down independent of each other with regards to start, rise and fall time(s). Voltage Ramp-up from a residual threshold (Eg : up to 1 V) should also lead to a normal startup of the device.
- The rate at which current is drawn from the external regulator ( $dI_{EXT}/dt$  or  $dI_{DD}/dt$ ) is limited in the Start-up phase to a maximum of 50 mA/100  $\mu$ s.
- PORST is active/asserted when either PORST (input) or PORST (output) is active/asserted.
- PORST (input) active means that the reset is held active by external agents by pulling the PORST pin low. It is recommended to keep the PORST (input) asserted until all the external supplies are above their primary reset thresholds.
- PORST (output) active means that  $\mu$ C asserts the reset internally and drives the PORST pin low thus propagating the reset to external devices. The PORST (output) is asserted by the  $\mu$ C when atleast one among the three supply domains (1.3 V, 3.3 V or 5 V) violate their primary under-voltage reset thresholds. The PORST (output) is deasserted by the  $\mu$ C when all supplies are above their primary reset thresholds and the basic supply and clock infrastructure is available.
- The power sequence as shown in [Figure 3-3](#) is enumerated below
  - T1 refers to the point in time when basic supply and clock infrastructure is available as the external supplies ramp up. The supply mode is evaluated based on the HWCFG [0:2] pins and consequently a soft start of EVR33 regulator is initiated.
  - T2 refers to the point in time when all supplies are above their primary reset thresholds. EVR33 regulator has ramped up. PORST (output) is deasserted and HWCFG [0:7] pins are latched on PORST rising edge. Firmware execution is initiated.
  - T3 refers to the point in time when Firmware execution is completed. User code execution starts with a default frequency of 100 MHz.
  - T4 refers to the point in time during the Ramp-down phase when atleast one of the externally provided or generated supplies (1.3 V, 3.3 V or 5 V) drop below their respective primary under-voltage reset thresholds.

Please note that there is no special requirements for  $\overline{PORST}$  slew rates.

Electrical Specification Power-up and Power-down

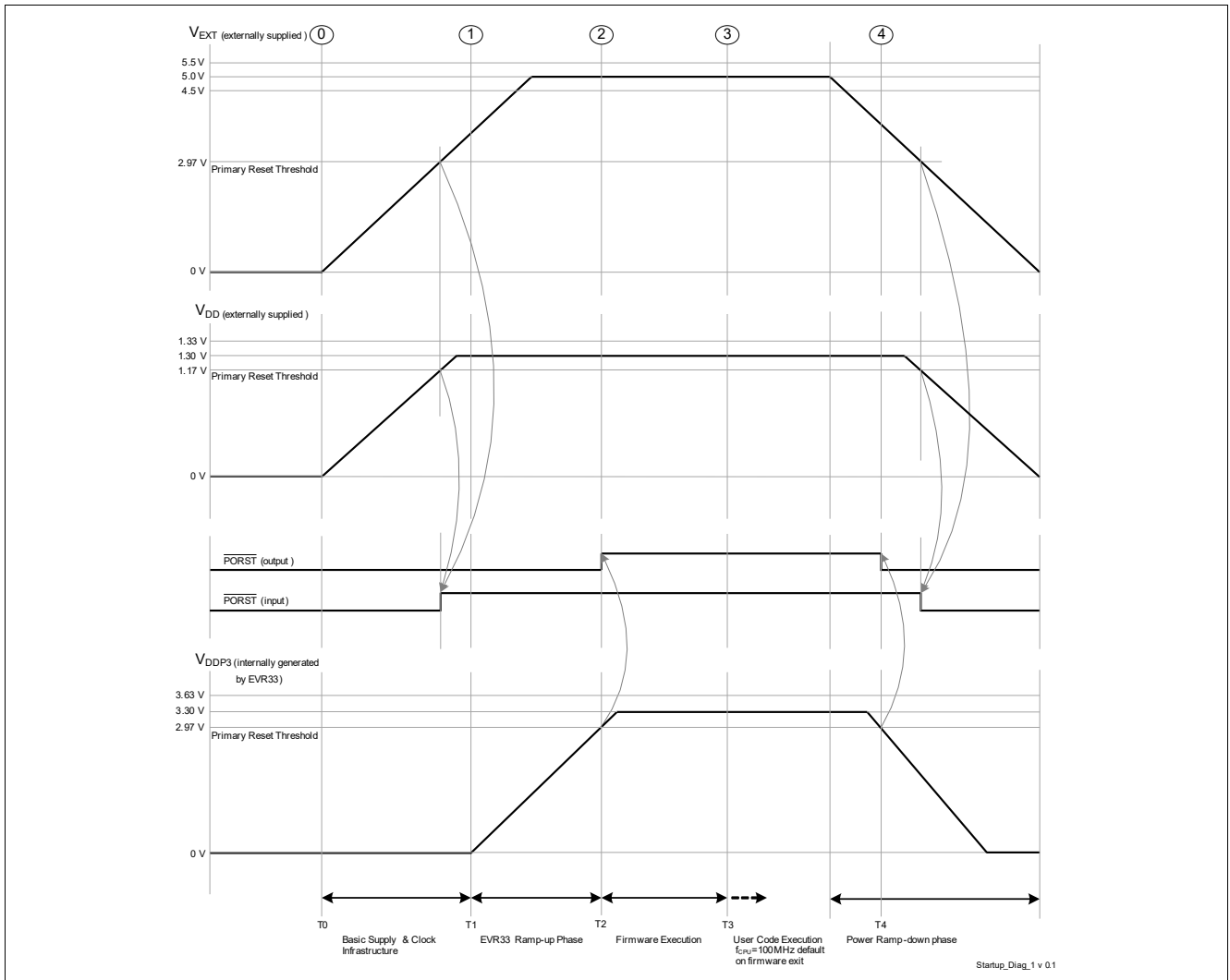

Figure 3-3 External Supply Mode - 5 V and 1.3 V externally supplied

### 3.15.2 Single Supply Mode

5 V single supply mode. 1.3 V & 3.3 V are generated internally by EVR13 & EVR33.

- The rate at which current is drawn from the external regulator ( $dI_{EXT}/dt$ ) is limited in the Start-up phase to a maximum of 50 mA/100  $\mu$ s.
- PORST is active/asserted when either PORST (input) or PORST (output) is active/asserted.
- PORST (input) active means that the reset is held active by external agents by pulling the PORST pin low. It is recommended to keep the PORST (input) asserted until the external supply is above the respective primary reset threshold.
- PORST (output) active means that  $\mu$ C asserts the reset internally and drives the PORST pin low thus propagating the reset to external devices. The PORST (output) is asserted by the  $\mu$ C when at least one among the three supply domains (1.3 V, 3.3 V or 5 V) violate their primary under-voltage reset thresholds. The PORST (output) is deasserted by the  $\mu$ C when all supplies are above their primary reset thresholds and the basic supply and clock infrastructure is available.
- The power sequence as shown in [Figure 3-4](#) is enumerated below
  - T1 refers to the point in time when basic supply and clock infrastructure is available as the external supply ramps up. The supply mode is evaluated based on the HWCFG [0:2] pins and consequently a soft start of EVR13 and EVR33 regulators are initiated.
  - T2 refers to the point in time when all supplies are above their primary reset thresholds. EVR13 and EVR33 regulators have ramped up. PORST (output) is deasserted and HWCFG [0:7] pins are latched on PORST rising edge. Firmware execution is initiated.
  - T3 refers to the point in time when Firmware execution is completed. User code execution starts with a default frequency of 100 MHz.
  - T4 refers to the point in time during the Ramp-down phase when at least one of the externally provided or generated supplies (1.3 V, 3.3 V or 5 V) drop below their respective primary under-voltage reset thresholds.

Please note that there is no special requirements for  $\overline{\text{PORST}}$  slew rates.

Electrical Specification Power-up and Power-down

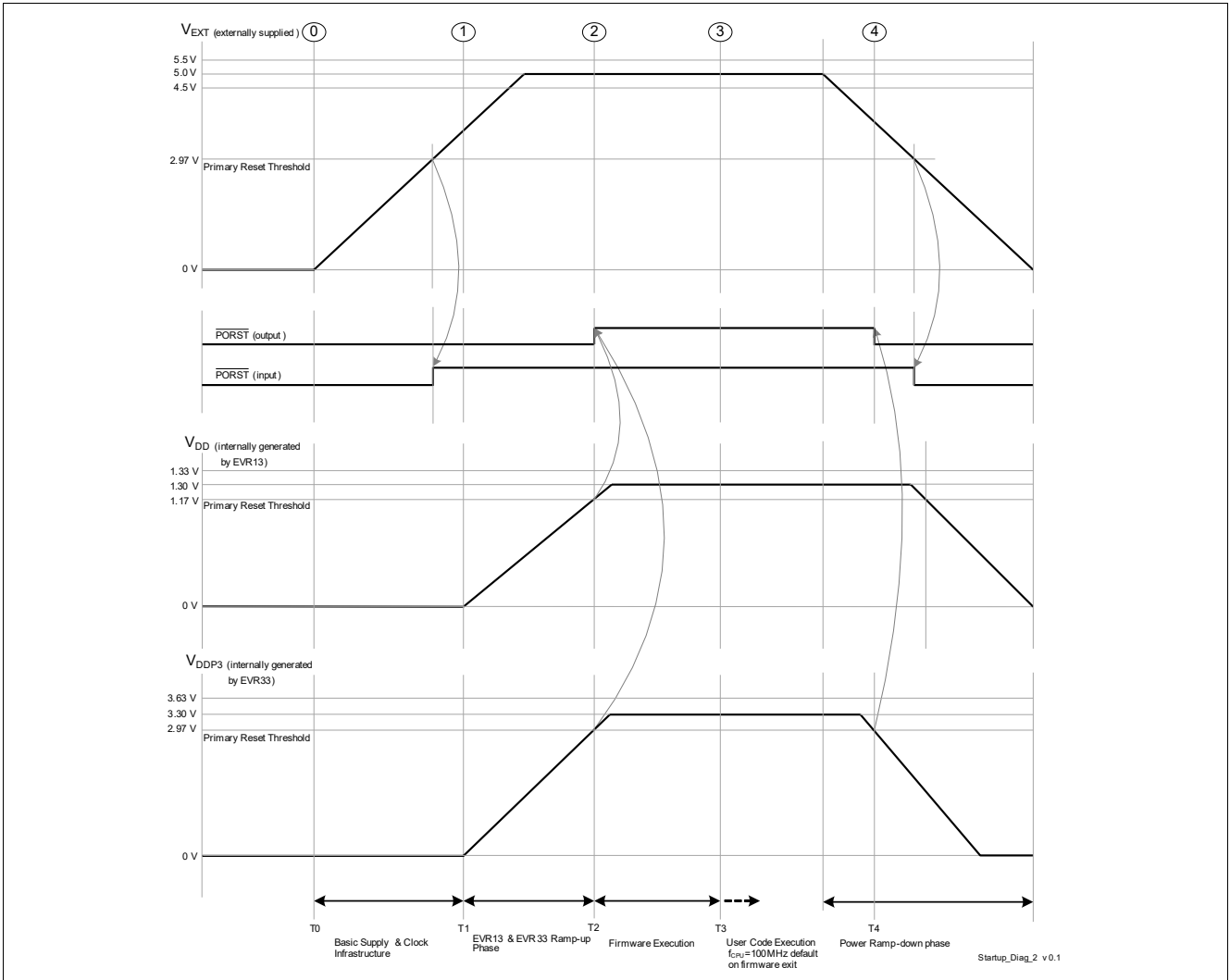

Figure 3-4 Single Supply Mode - 5 V single supply

### 3.15.3 External Supply Mode

All supplies, namely 5 V, 3.3 V & 1.3 V, are externally supplied.

- External supplies VEXT, VDDP3 & VDD may ramp-up or ramp-down independent of each other with regards to start, rise and fall time(s).
- The rate at which current is drawn from the external regulator ( $dI_{EXT}/dt$ ,  $dI_{DD}/dt$  or  $dI_{DDP3}/dt$ ) is limited in the Start-up phase to a maximum of 50 mA/100 us.
- PORST is active/asserted when either PORST (input) or PORST (output) is active/asserted.
- PORST (input) active means that the reset is held active by external agents by pulling the PORST pin low. It is recommended to keep the PORST (input) asserted until all the external supplies are above their primary reset thresholds.
- PORST (output) active means that  $\mu C$  asserts the reset internally and drives the PORST pin low thus propagating the reset to external devices. The PORST (output) is asserted by the  $\mu C$  when at least one among the three supply domains (1.3 V, 3.3 V or 5 V) violate their primary under-voltage reset thresholds. The PORST (output) is deasserted by the  $\mu C$  when all supplies are above their primary reset thresholds and the basic supply and clock infrastructure is available.
- The power sequence as shown in [Figure 3-5](#) is enumerated below
  - T1 refers to the point in time when all supplies are above their primary reset thresholds and basic clock infrastructure is available. The supply mode is evaluated based on the HWCFG [0:2] pins. PORST (output) is deasserted and HWCFG [0:7] pins are latched on PORST rising edge. Firmware execution is initiated.
  - T2 refers to the point in time when Firmware execution is completed. User code execution starts with a default frequency of 100 MHz.
  - T3 refers to the point in time during the Ramp-down phase when at least one of the externally provided supplies (1.3 V, 3.3 V or 5 V) drop below their respective primary under-voltage reset thresholds.

Please note that there is no special requirements for  $\overline{PORST}$  slew rates.

Electrical Specification Power-up and Power-down

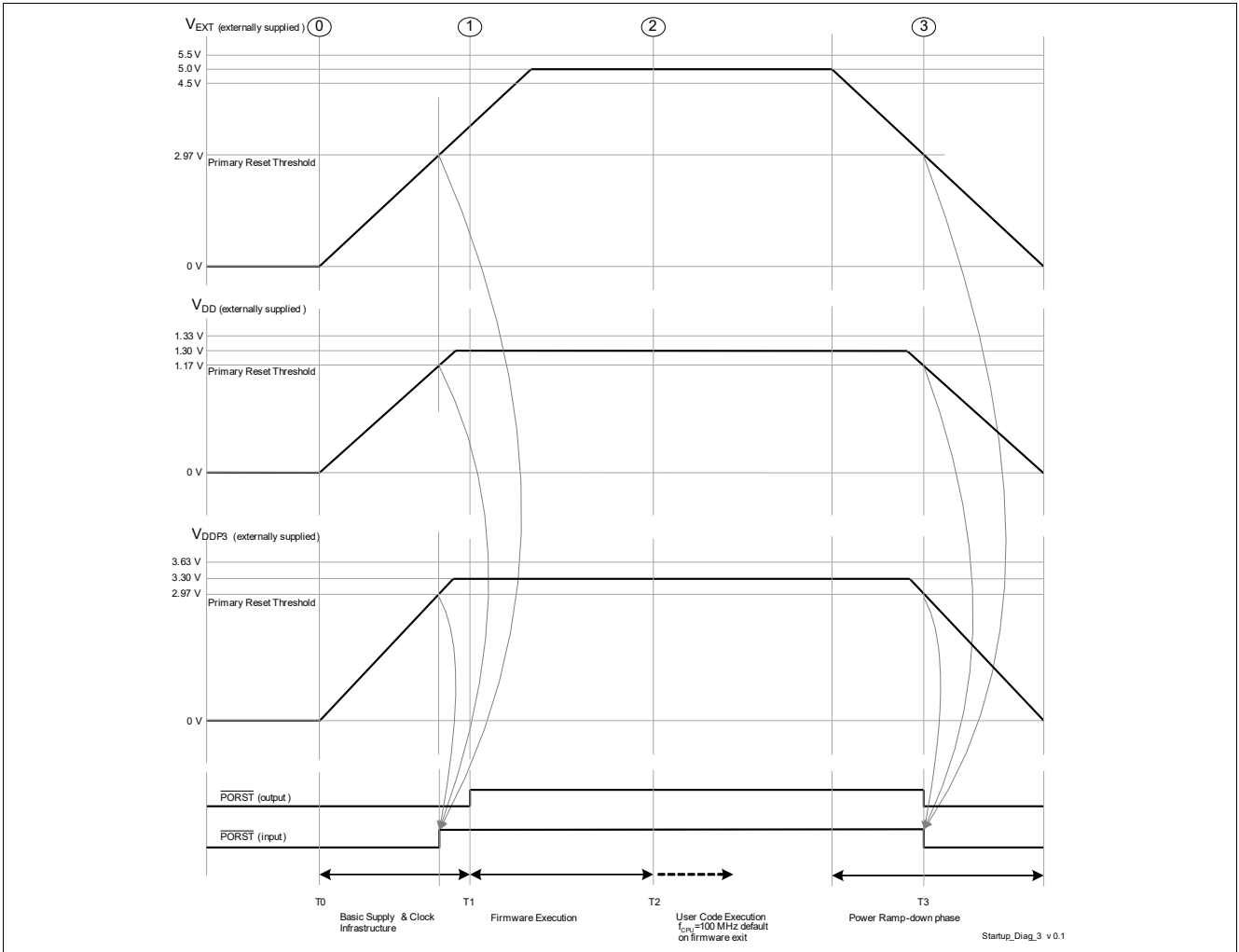

Figure 3-5 External Supply Mode - 5 V, 3.3 V & 1.3 V externally supplied

### 3.15.4 Single Supply Mode

3.3 V single supply mode. 1.3 V is generated internally by EVR13.

- The rate at which current is drawn from the external regulator ( $dI_{EXT}/dt$ ) is limited in the Start-up phase to a maximum of 50 mA/100  $\mu$ s.
- PORST is active/asserted when either PORST (input) or PORST (output) is active/asserted.
- PORST (input) active means that the reset is held active by external agents by pulling the PORST pin low. It is recommended to keep the PORST (input) asserted until the external supply is above the respective primary reset threshold.
- PORST (output) active means that  $\mu$ C asserts the reset internally and drives the PORST pin low thus propagating the reset to external devices. The PORST (output) is asserted by the  $\mu$ C when at least one among the three supply domains (1.3 V or 3.3 V) violate their primary under-voltage reset thresholds. The PORST (output) is deasserted by the  $\mu$ C when all supplies are above their primary reset thresholds and the basic supply and clock infrastructure is available.
- The power sequence as shown in [Figure 3-6](#) is enumerated below
  - T1 refers to the point in time when basic supply and clock infrastructure is available as the external supply ramps up. The supply mode is evaluated based on the HWCFG [0:2] pins and consequently a soft start of EVR13 regulator is initiated.
  - T2 refers to the point in time when all supplies are above their primary reset thresholds. EVR13 regulator has ramped up. PORST (output) is deasserted and HWCFG [0:7] pins are latched on PORST rising edge. Firmware execution is initiated.
  - T3 refers to the point in time when Firmware execution is completed. User code execution starts with a default frequency of 100 MHz.
  - T4 refers to the point in time during the Ramp-down phase when at least one of the externally provided or generated supplies (1.3 V or 3.3 V) drop below their respective primary under-voltage reset thresholds.

Please note that there is no special requirements for  $\overline{PORST}$  slew rates.

Electrical Specification Power-up and Power-down

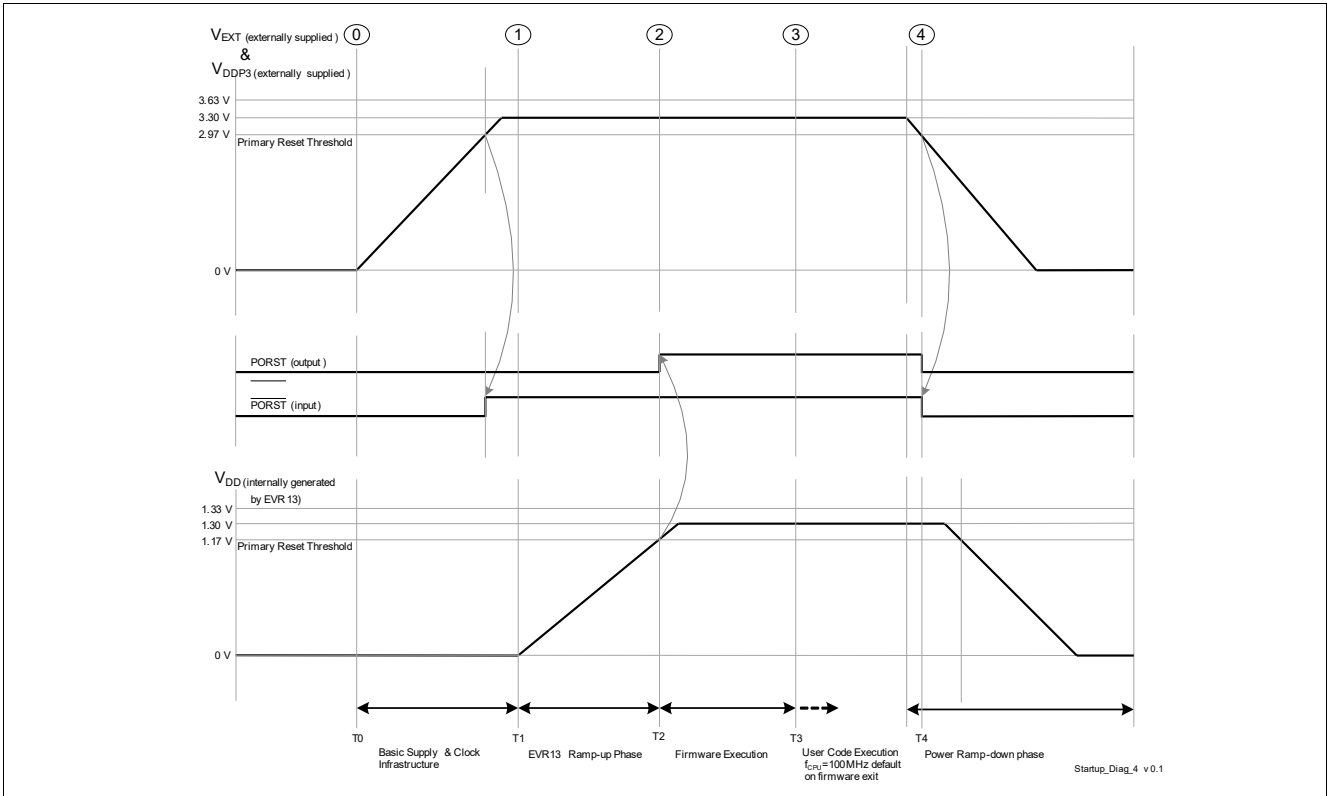

Figure 3-6 Single Supply Mode - 3.3 V single supply

### 3.16 Reset Timing

**Table 3-35 Reset Timings**

Parameter	Symbol	Values			Unit	Note / Test Condition
		Min.	Typ.	Max.		
Application Reset Boot Time <sup>1)</sup>	$t_B$ CC	-	-	350 <sup>2)</sup>	$\mu$ s	operating with max. frequencies.
System Reset Boot Time	$t_{BS}$ CC	-	-	1	ms	
Power on Reset Boot Time <sup>3)</sup>	$t_{BP}$ CC	-	-	2.5 <sup>2)</sup>	ms	$dV/dT=1V/ms$ . including EVR ramp-up and Firmware execution time
		-	-	1.11 <sup>2)</sup>	ms	Firmware execution time; without EVR operation (external supply only)
Minimum PORST hold time in case of power fail event issued by EVR primary monitor	$t_{EVRPOR}$ CC	10	-	-	$\mu$ s	
EVR start-up or ramp-up time	$t_{EVRstartup}$ CC	-	-	1	ms	$dV/dT=1V/ms$ . EVR13 and EVR33 active
Minimum PORST active hold time after power supplies are stable at operating levels <sup>4)</sup>	$t_{POA}$ CC	1	-	-	ms	
Configurable PORST digital filter delay in addition to analog pad filter delay	$t_{PORSTDF}$ CC	600	-	1200	ns	
HWCFG pins hold time from ESR0 rising edge	$t_{HDH}$ CC	$16 / f_{SPB}$	-	-	ns	
HWCFG pins setup time to ESR0 rising edge	$t_{HDS}$ CC	0	-	-	ns	
Ports inactive after ESR0 reset active	$t_{PI}$ CC	-	-	$8/f_{SPB}$	ns	
Ports inactive after PORST reset active <sup>5)</sup>	$t_{PIP}$ CC	-	-	150	ns	
Hold time from PORST rising edge	$t_{POH}$ SR	150	-	-	ns	
Setup time to PORST rising edge	$t_{POS}$ SR	0	-	-	ns	

1) The duration of the boot time is defined between the rising edge of the internal application reset and the clock cycle when the first user instruction has entered the CPU pipeline and its processing starts.

2) The timing values assumes programmed BMI with ESR0CNT inactive.

3) The duration of the boot time is defined by all external supply voltages are inside there operation condicions and the clock cycle when the first user instruction has entered the CPU pipeline and its processing starts.

Electrical Specification Reset Timing

- 4) The regulator that supplies  $V_{EXT}$  should ensure that  $V_{EXT}$  is in the operational region before PORST is externally released by the regulator. In case of 5V nominal supply, it should be ensured that  $V_{EXT} > 4V$  before PORST is released. In case of 3.3V nominal supply, it should be ensured that  $V_{EXT} > 3V$  before PORST is released. The additional minimum PORST hold time is required as an additional mechanism to avoid consecutive PORST toggling owing to slow supply slopes or residual supply ramp-ups. It is also required to activate external PORST at least 100us before power-fail is recognised to avoid consecutive PORST toggling on a power fail event.
- 5) This parameter includes the delay of the analog spike filter in the  $\overline{PORST}$  pad.

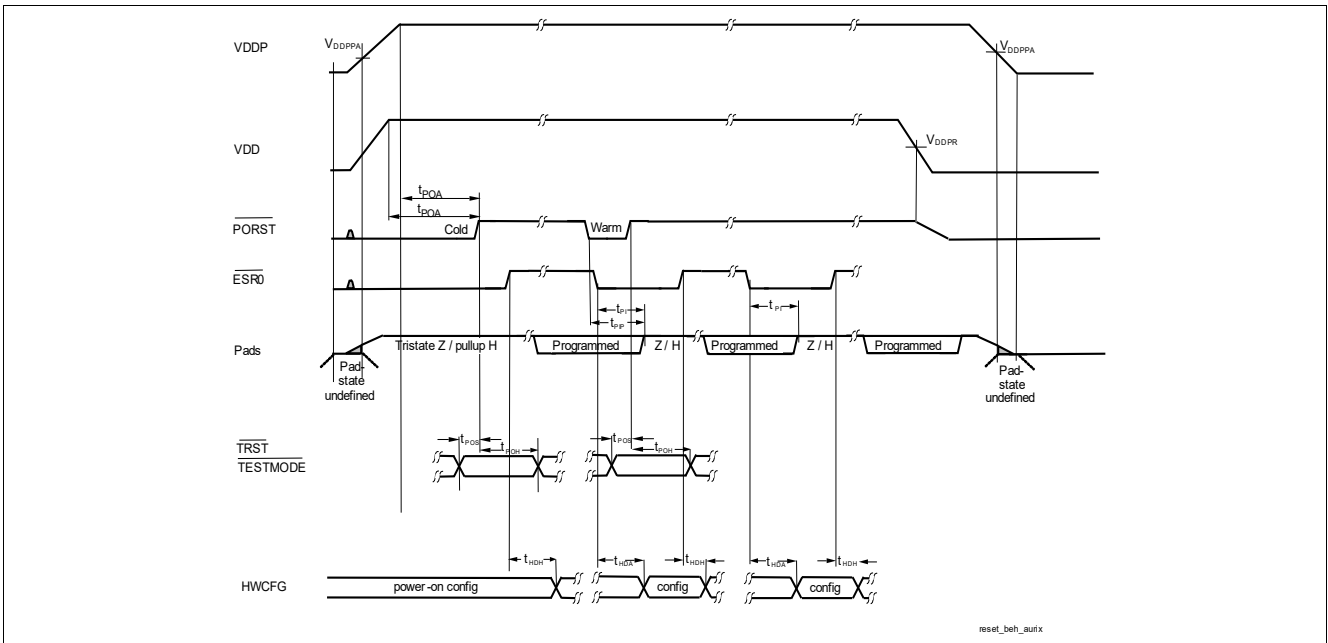

Figure 3-7 Power, Pad and Reset Timing

## 3.17 EVR

Table 3-36 3.3V

Parameter	Symbol	Values			Unit	Note / Test Condition
		Min.	Typ.	Max.		
Input voltage range <sup>1)</sup>	$V_{IN}$ SR	4	-	5.50	V	pass device=on chip
Output voltage operational range including load/line regulation and aging incase of LDO regulator	$V_{OUT}$ CC	2.97	3.3	3.63	V	pass device=on chip
Output $V_{DDX3}$ static voltage accuracy after trimming and aging without dynamic load/line Regulation incase of LDO regulator.	$V_{OUTT}$ CC	3.225	3.3	3.375	V	pass device=on chip
Output buffer capacitance on $V_{OUT}$ <sup>2)</sup>	$C_{OUT}$ CC	-	1	-	$\mu$ F	pass device=on chip
Primary Undervoltage Reset threshold for $V_{DDX3}$ <sup>3)</sup>	$V_{RST33}$ CC	-	-	3.0	V	by reset release before EVR trimming on supply ramp-up.
Startup time	$t_{STR}$ CC	-	-	1000	$\mu$ s	Only EVR33 active. ; pass device=on chip
External $V_{IN}$ supply ramp <sup>4)</sup>	$dV_{in}/dT$ SR	-	1	50	V/ms	pass device=on chip
Load step response	$dV_{out}/dI_{out}$ CC	-	-	240	mV	$dI=-70mA/20ns$ ; $T_{settle}=20us$ ; pass device=on chip
		-240	-	-	mV	$dI=50mA/20ns$ ; $T_{settle}=100us$ ; pass device=on chip
Line step response	$dV_{out}/dV_{in}$ CC	-20	-	20	mV	$dV/dT=1V/ms$ ; pass device=on chip

- 1) A maximum pass device dropout voltage of 700mV is included in the minimum input voltage to ensure optimal pass device operation.
- 2) It is recommended to select a capacitor with ESR less than 50 mOhm (0.5MHz - 10 MHz). It is also recommended that the resistance of the supply trace from the pin to the EVR output capacitor is less than 100 mOhm.
- 3) The reset release on supply ramp-up is delayed by a time duration 20-40 us after reaching undervoltage reset threshold. This serves as a time hysteresis to avoid multiple consecutive cold PORST events during slow supply ramp-ups owing to voltage drop/current jumps when reset is released. The reset limit of 2.97V at pin is for the case with 3.3V generated internally from EVR33. In case the 3.3V supply is provided externally, the bondwire drop will cause a reset at a higher voltage of 3.0V at the  $V_{DDP3}$  pin.
- 4) EVR robust against residual voltage ramp-up starting between 0-1 V.

Table 3-37 1.3V

Parameter	Symbol	Values			Unit	Note / Test Condition
		Min.	Typ.	Max.		
Input voltage range <sup>1)</sup>	$V_{IN}$ SR	2.97	-	5.5	V	pass device=off chip
Output voltage operational range including load/line regulation and aging incase of LDO regulator	$V_{OUT}$ CC	1.17	1.3	1.43	V	pass device=off chip
Output $V_{DD}$ static voltage accuracy after trimming without dynamic load/line regulation with aging incase of LDO regulator.	$V_{OUTT}$ CC	1.275	1.3	1.325	V	pass device=off chip
Output buffer capacitance on $V_{OUT}$ <sup>2)</sup>	$C_{OUT}$ CC	3	4.7	6.3	$\mu$ F	pass device=off chip
Primary undervoltage reset threshold for $V_{DD}$ <sup>3)</sup>	$V_{RST13}$ CC	-	-	1.17	V	by reset release before EVR trimming on supply ramp-up. pass device=off chip
Startup time	$t_{STR}$ CC	-	-	1000	$\mu$ s	pass device=off chip. Only EVR13 active.
External $V_{IN}$ supply ramp <sup>4)</sup>	$dV_{in}/dT$ SR	-	1	50	V/ms	pass device=off chip
Load step response	$dV_{out}/dI_{out}$ CC	-	-	100	mV	$dI=-150mA$ ; $T_{settle}=20\mu s$ ; pass device=off chip
		-100	-	-	mV	$dI=100mA$ ; $T_{settle}=20\mu s$ ; pass device=off chip
Line step response	$dV_{out}/dV_{in}$ CC	-10	-	10	mV	$dV/dT=1V/ms$ ; pass device=off chip

1) A maximum pass device dropout voltage of 700mV is included in the minimum input voltage to ensure optimal pass device operation.

2) It is recommended to select a capacitor with ESR less than 50 mOhm (0.5MHz - 10 MHz). It is also recommended that the resistance of the supply trace from the pin to the EVR output capacitor is less than 100 mOhm.

3) The reset release on supply ramp-up is delayed by a time duration 30-60  $\mu$ s after reaching undervoltage reset threshold. This serves as a time hysteresis to avoid multiple consecutive cold PORST events during slow supply ramp-ups owing to voltage drop/current jumps when reset is released.

4) EVR robust against residual voltage ramp-up starting between 0-1 V.

**Table 3-38 Supply Monitoring**

Parameter	Symbol	Values			Unit	Note / Test Condition
		Min.	Typ.	Max.		
$V_{EXT}$ primary undervoltage monitor accuracy after trimming <sup>1)</sup>	$V_{EXTPRIUV}$ SR	2.86	2.92	2.97	V	$V_{EXT}$ = Undervoltage Reset Threshold
$V_{DDP3}$ primary undervoltage monitor accuracy after trimming <sup>1)</sup>	$V_{DDP3PRIUV}$ SR	2.86	2.90	2.97	V	$V_{DDP3}$ = Undervoltage Reset Threshold
$V_{DD}$ primary undervoltage monitor accuracy after trimming <sup>1)</sup>	$V_{DDPRIUV}$ SR	1.13	1.15	1.17	V	$V_{DD}$ = Undervoltage Reset Threshold
$V_{EXT}$ secondary supply monitor accuracy	$V_{EXTMON}$ CC	4.9	5.0	5.1	V	SWDxxVAL $V_{EXT}$ monitoring threshold=5V=DBh
$V_{DDP3}$ secondary supply monitor accuracy	$V_{DDP3MON}$ CC	3.23	3.30	3.37	V	EVR33xxVAL $V_{DDP3}$ monitoring threshold=3.3V=91h
$V_{DD}$ secondary supply monitor accuracy	$V_{DDMON}$ CC	1.27	1.30	1.33	V	EVR13xxVAL $V_{DD}$ monitoring threshold=1.3V=E4h
EVR primary and secondary monitor measurement latency for a new supply value	$t_{EVROMON}$ CC	-	-	1.8	$\mu$ s	after trimming

1) The monitor tolerances constitute the inherent variation of the bandgap and ADC over process, voltage and temperature operational ranges. The xxxPRIUV parameters are device individually tested in production with  $\pm 1\%$  tolerance about the min and max xxxPRIUV limits.

**Table 3-39 EVR13 SMPS External components**

Parameter	Symbol	Values			Unit	Note / Test Condition
		Min.	Typ.	Max.		
External output capacitor value <sup>1)</sup>	$C_{OUTDC}$ SR	15.4	22	29.7	$\mu$ F	$I_{DDDC}=1A$
		6.5	10	13.5	$\mu$ F	$I_{DDDC}=400mA$
External output capacitor ESR	$C_{DC\_ESR}$ SR	-	-	50	mOhm	$f \geq 0.5MHz$ ; $f \leq 10MHz$
		-	-	100	Ohm	$f = 10Hz$
External input capacitor value <sup>1)</sup>	$C_{IN}$ SR	6.5	10	13.5	$\mu$ F	$I_{DDDC}=1A$
		4.42	6.8	9.18	$\mu$ F	$I_{DDDC}=400mA$
External input capacitor ESR	$C_{IN\_ESR}$ SR	-	-	50	mOhm	$f \geq 0.5MHz$ ; $f \leq 10MHz$
		-	-	100	Ohm	$f = 100Hz$
External inductor value <sup>2)</sup>	$L_{DC}$ SR	2.31	3.3	4.29	$\mu$ H	$f_{DCDC}=1.5MHz$
		3.29	4.7	6.11	$\mu$ H	$f_{DCDC}=1MHz$
External inductor ESR	$L_{DC\_ESR}$ SR	-	-	0.2	Ohm	
P + N-channel MOSFET logic level	$V_{LL}$ SR	-	-	2.5	V	

**Table 3-39 EVR13 SMPS External components (cont'd)**

Parameter	Symbol	Values			Unit	Note / Test Condition
		Min.	Typ.	Max.		
P + N-channel MOSFET drain source breakdown voltage	$ V_{BR\_DS} $ SR	-	-	7	V	
P + N-channel MOSFET drain source ON-state resistance	$R_{ON}$ SR	-	-	150	mOhm	$I_{DDDC}=1A; V_{GS}=2.5V;$ $T_A=25^\circ C$
		-	-	200	mOhm	$I_{DDDC}=400mA; V_{GS}=2.5V;$ $T_A=25^\circ C$
P + N-channel MOSFET Gate Charge	$Q_{ac}$ SR	-	4	-	nC	$I_{DDDC}=1A; MOS-$ $V_{GS}=5V$
		-	8	-	nC	$I_{DDDC}=400mA; MOS-$ $V_{GS}=5V$
External MOSFET commutation time	$t_c$ SR	10	30	40	ns	configurable
N-channel MOSFET reverse diode forward voltage	$V_{RDN}$ SR	-	0.8	-	V	

1) Capacitor min-max range represent typical  $\pm 35\%$  tolerance including DC bias effect. The trace resistance from the capacitor to the supply or ground rail should be limited to 25 mOhm.

2) External inductor min-max range represent typical  $\pm 30\%$  tolerance at a DC bias current of 100mA.

**Table 3-40 EVR13 SMPS**

Parameter	Symbol	Values			Unit	Note / Test Condition
		Min.	Typ.	Max.		
Input $V_{EXT}$ Voltage range	$V_{IN}$ SR	2.97	-	5.5	V	
SMPS regulator output voltage range including load/line regulation and aging <sup>1)</sup>	$V_{DDDC}$ CC	1.17	-	1.43	V	$V_{DD} \geq 2.97V; V_{DD} \leq 5.5V$ ; $I_{DDDC} \geq 1mA$ ; $I_{DDDC} \leq 1A$
SMPS regulator static voltage output accuracy after trimming without dynamic load/line Regulation with aging. <sup>2)</sup>	$V_{DDDC T}$ CC	1.275	1.3	1.325	V	$V_{DD} \geq 2.97V; V_{DD} \leq 5.5V$ ; $I_{DDDC} \geq 1mA$ ; $I_{DDDC} \leq 1A$
Programmable switching frequency	$f_{DCDC}$ CC	0.4	-	2.0	MHz	
Switching frequency modulation spread	$\Delta f_{DCSPR}$ CC	-	-	2%	MHz	
Maximum ripple at $I_{MAX}$ (peak-to-peak) <sup>3)</sup>	$\Delta V_{DDDC}$ CC	-	-	15	mV	$V_{DD} \geq 2.97V; V_{DD} \leq 5.5V$ ; $I_{DDDC} \geq 300mA$ ; $I_{DDDC} \leq 1A$
No load current consumption of SMPS regulator	$I_{DCNL}$ CC	-	5	10	mA	$f_{DCDC}=1MHz$

Table 3-40 EVR13 SMPS (cont'd)

Parameter	Symbol	Values			Unit	Note / Test Condition
		Min.	Typ.	Max.		
SMPS regulator load transient response	$dV_{out}/dI_{out}$ CC	-25	-	25	mV	$dI < 200mA$ ; $f_{DCDC}=1MHz$ ; $t_f=0.1\mu s$ ; $t_f=0.1\mu s$ ; $V_{DDDC}=1.3V$
		-65	-	65	mV	$dI < 400mA$ ; $f_{DCDC}=1MHz$ ; $t_f=0.1\mu s$ ; $t_f=0.1\mu s$ ; $V_{DDDC}=1.3V$
		-130	-	130	mV	$dI < 700mA$ ; $f_{DCDC}=1MHz$ ; $t_f=0.1\mu s$ ; $t_f=0.1\mu s$ ; $V_{DDDC}=1.3V$
Maximum output current of the regulator	$I_{MAX}$ SR	-	-	1	A	limited by thermal constraints and component choice
SMPS regulator efficiency	$\eta_{DC}$ CC	-	85	-	%	$V_{IN}=3.3V$ ; $I_{DDDC}=300mA$ ; $f_{DCDC}=1MHz$
		-	75	-	%	$V_{IN}=5V$ ; $I_{DDDC}=400mA$ ; $f_{DCDC}=1.5MHz$
		-	80	-	%	$V_{IN}=5V$ ; $I_{DDDC}=400mA$ ; $f_{DCDC}=1MHz$

- 1) In case of SMPS mode, it shall be ensured that the  $V_{DD}$  output pin shall be connected on PCB level to all other  $V_{DD}$  Input pins.
- 2) In case of  $f_{SRI}$  running with max frequency, it shall be ensured that the  $V_{DD}$  operating range is limited to 1.235V upto 1.430V. The DCDC may be configured in this case with a nominal voltage of  $1.33V \pm 7.5\%$ . The static accuracy and regulation parameter ranges remain also valid for this case.
- 3) If frequency spreading (SDFREQSPRD = 1) is activated, an additional ripple of 1% need to be considered.

### 3.18 Phase Locked Loop (PLL)

Table 3-41 PLL

Parameter	Symbol	Values			Unit	Note / Test Condition
		Min.	Typ.	Max.		
PLL base frequency	$f_{\text{PLLBASE}}$ CC	80	150	360	MHz	
VCO frequency range	$f_{\text{VCO}}$ SR	400	-	800	MHz	
VCO Input frequency range	$f_{\text{REF}}$ CC	8	-	24	MHz	
Modulation Amplitude	$MA$ CC	0	-	2	%	
Peak Period jitter	$DP$ CC	-200	-	200	ps	
Peak Accumulated Jitter	$D_{\text{PP}}$ CC	-5	-	5	ns	without modulation
Total long term jitter	$J_{\text{TOT}}$ CC	-	-	11.5	ns	including modulation; $MA \leq 1\%$
System frequency deviation	$f_{\text{SYSD}}$ CC	-	-	0.01	%	with active modulation
Modulation variation frequency	$f_{\text{MV}}$ CC	2	3.6	5.4	MHz	
PLL lock-in time	$t_{\text{L}}$ CC	11.5	-	200	$\mu\text{s}$	

Note: The specified PLL jitter values are valid if the capacitive load per pin does not exceed  $C_L = 20 \text{ pF}$  with the maximum driver and sharp edge.

Note: The maximum peak-to-peak noise on the power supply voltage, is limited to a peak-to-peak voltage of  $V_{\text{PP}} = 100 \text{ mV}$  for noise frequencies below 300 KHz and  $V_{\text{PP}} = 40 \text{ mV}$  for noise frequencies above 300 KHz. These conditions can be achieved by appropriate blocking of the supply voltage as near as possible to the supply pins and using PCB supply and ground planes.

### 3.19 ERAY Phase Locked Loop (ERAY\_PLL)

Table 3-42 PLL\_ERAY

Parameter	Symbol	Values			Unit	Note / Test Condition
		Min.	Typ.	Max.		
PLL Base Frequency of the ERAY PLL	$f_{\text{PLLBASE\_ERAY CC}}$	50	200	320	MHz	
VCO frequency range of the ERAY PLL	$f_{\text{VCO\_ERAY SR}}$	400	-	480	MHz	
VCO input frequency of the ERAY PLL	$f_{\text{REF SR}}$	16	-	24	MHz	
Accumulated_Jitter	$D_{\text{P CC}}$	-0.5	-	0.5	ns	
Accumulated jitter at SYSCLK pin	$D_{\text{PP CC}}$	-0.8	-	0.8	ns	
PLL lock-in time	$t_{\text{L CC}}$	5.6	-	200	$\mu\text{s}$	

Note: The specified PLL jitter values are valid if the capacitive load per pin does not exceed  $C_L = 20 \text{ pF}$  with the maximum driver and sharp edge.

Note: The maximum peak-to-peak noise on the power supply voltage, is limited to a peak-to-peak voltage of  $V_{\text{PP}} = 100 \text{ mV}$  for noise frequencies below 300 KHz and  $V_{\text{PP}} = 40 \text{ mV}$  for noise frequencies above 300 KHz. These conditions can be achieved by appropriate blocking of the supply voltage as near as possible to the supply pins and using PCB supply and ground planes.

### 3.20 AC Specifications

All AC parameters are specified for the complete operating range defined in [Chapter 3.4](#) unless otherwise noted in column Note / test Condition.

Unless otherwise noted in the figures the timings are defined with the following guidelines:

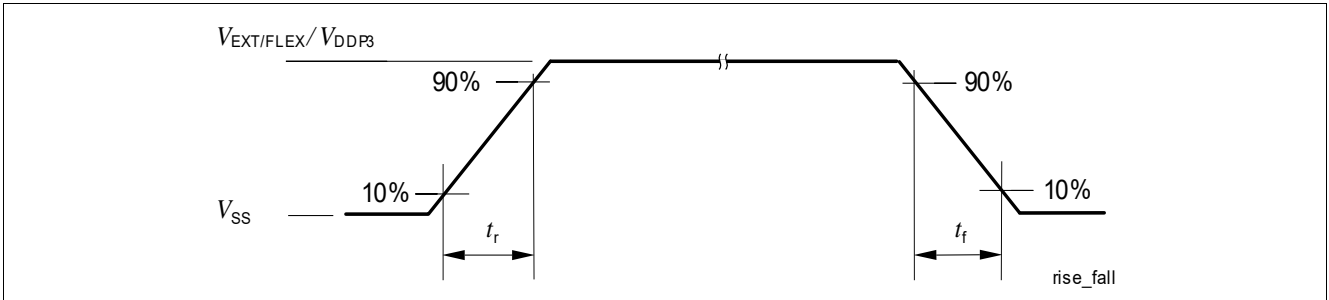

Figure 3-8 Definition of rise / fall times

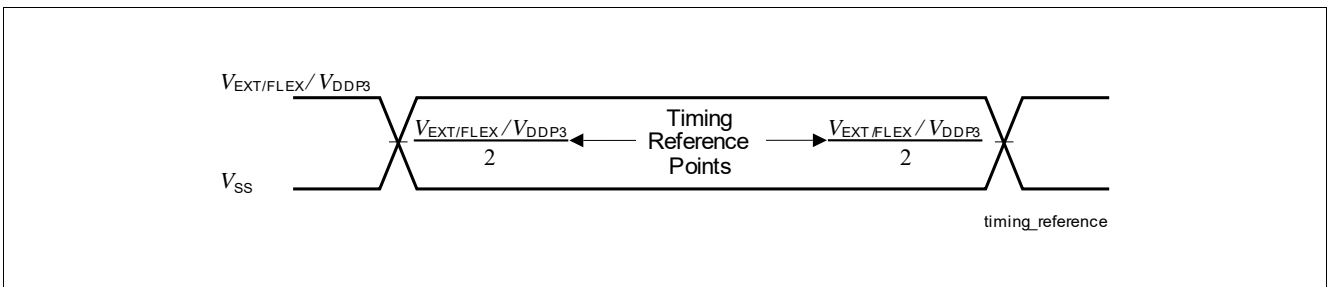

Figure 3-9 Time Reference Point Definition

### 3.21 JTAG Parameters

The following parameters are applicable for communication through the JTAG debug interface. The JTAG module is fully compliant with IEEE 1149.1-2000.

**Table 3-43 JTAG**

Parameter	Symbol	Values			Unit	Note / Test Condition
		Min.	Typ.	Max.		
TCK clock period	$t_1$ SR	25	-	-	ns	
TCK high time	$t_2$ SR	10	-	-	ns	
TCK low time	$t_3$ SR	10	-	-	ns	
TCK clock rise time	$t_4$ SR	-	-	4	ns	
TCK clock fall time	$t_5$ SR	-	-	4	ns	
TDI/TMS setup to TCK rising edge	$t_6$ SR	6.0	-	-	ns	
TDI/TMS hold after TCK rising edge	$t_7$ SR	6.0	-	-	ns	
TDO valid after TCK falling edge (propagation delay) <sup>1)</sup>	$t_8$ CC	3.0	-	-	ns	$C_L \leq 20\text{pF}$
		-	-	16	ns	$C_L \leq 50\text{pF}$
TDO hold after TCK falling edge <sup>1)</sup>	$t_{18}$ CC	2	-	-	ns	
TDO high impedance to valid from TCK falling edge <sup>1)2)</sup>	$t_9$ CC	-	-	17.5	ns	$C_L \leq 50\text{pF}$
TDO valid output to high impedance from TCK falling edge <sup>1)</sup>	$t_{10}$ CC	-	-	17	ns	$C_L \leq 50\text{pF}$

- 1) The falling edge on TCK is used to generate the TDO timing.
- 2) The setup time for TDO is given implicitly by the TCK cycle time.

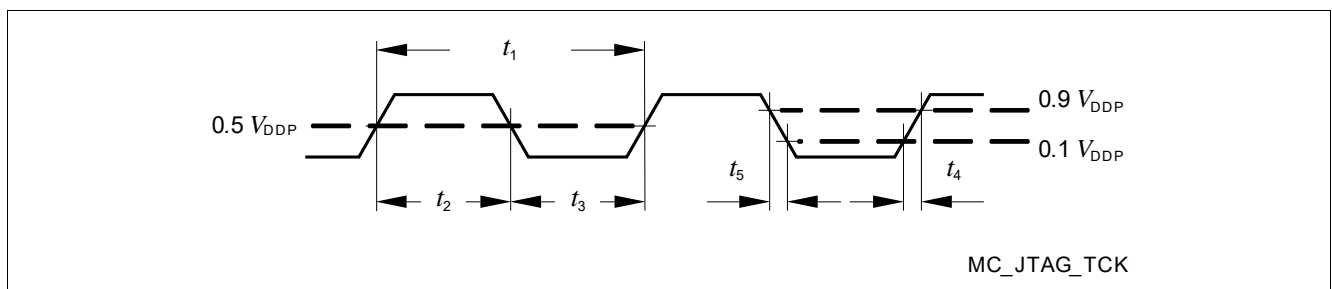

**Figure 3-10 Test Clock Timing (TCK)**

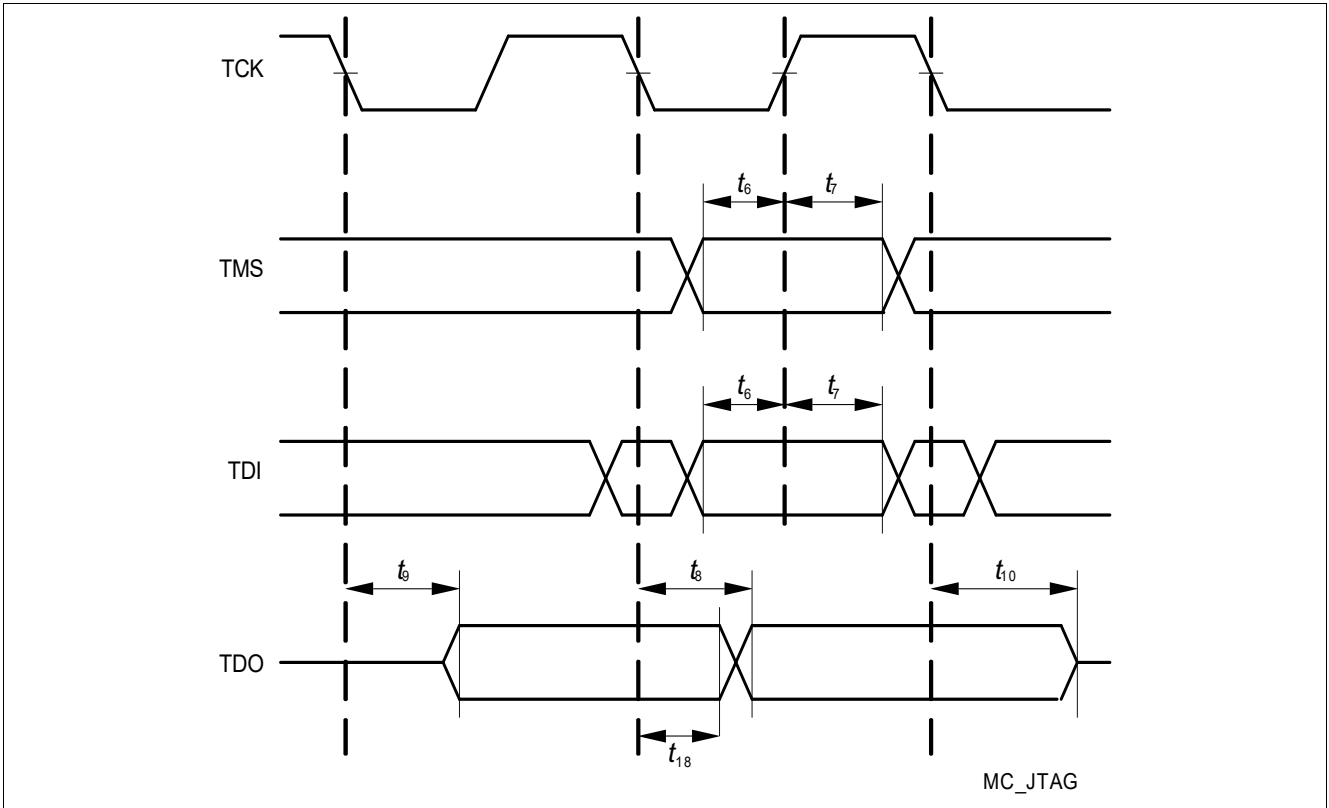

Figure 3-11 JTAG Timing

### 3.22 DAP Parameters

The following parameters are applicable for communication through the DAP debug interface.

Table 3-44 DAP

Parameter	Symbol	Values			Unit	Note / Test Condition
		Min.	Typ.	Max.		
DAP0 clock period	$t_{11}$ SR	6.25	-	-	ns	
DAP0 high time	$t_{12}$ SR	2	-	-	ns	
DAP0 low time	$t_{13}$ SR	2	-	-	ns	
DAP0 clock rise time	$t_{14}$ SR	-	-	1	ns	$f=160\text{MHz}$
		-	-	2	ns	$f=80\text{MHz}$
DAP0 clock fall time	$t_{15}$ SR	-	-	1	ns	$f=160\text{MHz}$
		-	-	2	ns	$f=80\text{MHz}$
DAP1 setup to DAP0 rising edge	$t_{16}$ SR	4	-	-	ns	
DAP1 hold after DAP0 rising edge	$t_{17}$ SR	2	-	-	ns	
DAP1 valid per DAP0 clock period <sup>1)</sup>	$t_{19}$ CC	3	-	-	ns	$C_L=20\text{pF} ; f=160\text{MHz}$
		8	-	-	ns	$C_L=20\text{pF} ; f=80\text{MHz}$
		10	-	-	ns	$C_L=50\text{pF} ; f=40\text{MHz}$

1) The Host has to find a suitable sampling point by analyzing the sync telegram response.

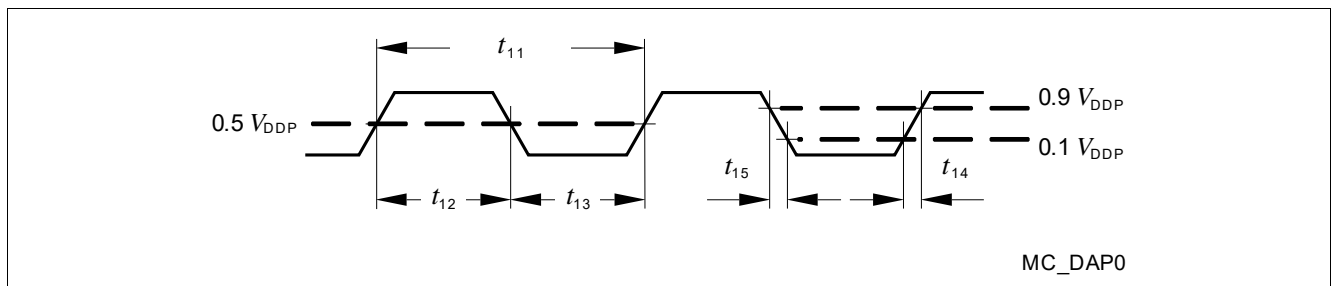

Figure 3-12 Test Clock Timing (DAP0)

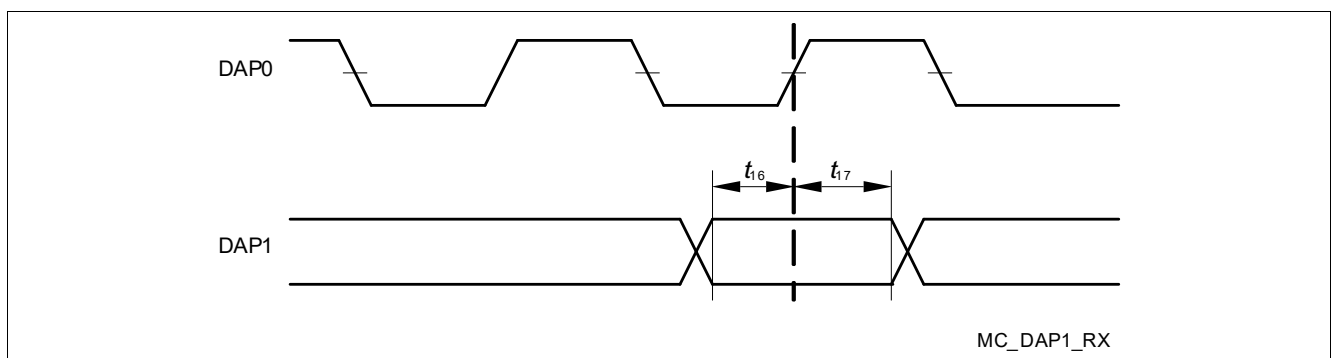
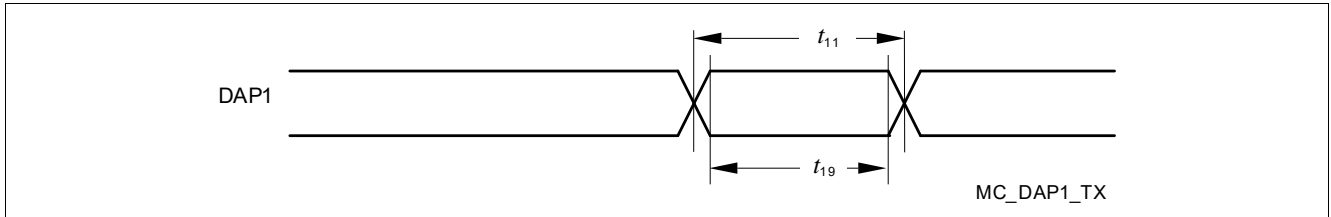

Figure 3-13 DAP Timing Host to Device



**Figure 3-14 DAP Timing Device to Host (DAP1 and DAP2 pins)**

*Note: The DAP1 and DAP2 device to host timing is individual for both pins. There is no guaranteed max. signal skew.*

### 3.23 ASCLIN SPI Master Timing

This section defines the timings for the ASCLIN in the TC270 / TC275 / TC277, for 5V power supply.

*Note: Pad asymmetry is already included in the following timings.*

**Table 3-45 Master Mode MP+ss/MPRss output pads**

Parameter	Symbol	Values			Unit	Note / Test Condition
		Min.	Typ.	Max.		
ASCLKO clock period <sup>1)</sup>	$t_{50}$ CC	20	-	-	ns	$C_L=25\text{pF}$
Deviation from ideal duty cycle <sup>2)</sup>	$t_{500}$ CC	-3	-	3	ns	$0 < C_L < 50\text{pF}$
MISR delay from ASCLKO shifting edge	$t_{51}$ CC	-7	-	6	ns	$C_L=25\text{pF}$
ASLSON delay from the first ASCLKO edge	$t_{510}$ CC	5	-	35	ns	$C_L=25\text{pF}$ ; pad used = LPm
MRST setup to ASCLKO latching edge	$t_{52}$ SR	28	-	-	ns	$C_L=25\text{pF}$
MRST hold from ASCLKO latching edge	$t_{53}$ SR	-6	-	-	ns	$C_L=25\text{pF}$

- 1) PLL Jitter not included. Should be considered additionally, corresponding to the used baudrate. The duty cycle can be adjusted using the BITCON.SAMPLEPOINT bitfield with the finest granularity of  $T_{MAX} = 1 / f_{MAX}$ .
- 2) Positive deviation lengthens the high time and shortens the low time of a clock period. Negative deviation does the opposite.

**Table 3-46 Master Mode MP+sm/MPRsm output pads**

Parameter	Symbol	Values			Unit	Note / Test Condition
		Min.	Typ.	Max.		
ASCLKO clock period <sup>1)</sup>	$t_{50}$ CC	50	-	-	ns	$C_L=50\text{pF}$
Deviation from ideal duty cycle <sup>2)</sup>	$t_{500}$ CC	-2	-	$3+0.01 \cdot C_L$ *	ns	$0 < C_L < 200\text{pF}$
MISR delay from ASCLKO shifting edge	$t_{51}$ CC	-10	-	10	ns	$C_L=50\text{pF}$
ASLSON delay from the first ASCLKO edge	$t_{510}$ CC	5	-	35	ns	$C_L=50\text{pF}$ ; pad used = LPm
MRST setup to ASCLKO latching edge	$t_{52}$ SR	50	-	-	ns	$C_L=50\text{pF}$
MRST hold from ASCLKO latching edge	$t_{53}$ SR	-10	-	-	ns	$C_L=50\text{pF}$

- 1) PLL Jitter not included. Should be considered additionally, corresponding to the used baudrate. The duty cycle can be adjusted using the BITCON.SAMPLEPOINT bitfield with the finest granularity of  $T_{MAX} = 1 / f_{MAX}$ .
- 2) Positive deviation lengthens the high time and shortens the low time of a clock period. Negative deviation does the opposite.

**Electrical Specification ASCLIN SPI Master Timing**
**Table 3-47 Master Mode MPss output pads**

Parameter	Symbol	Values			Unit	Note / Test Condition
		Min.	Typ.	Max.		
ASCLKO clock period <sup>1)</sup>	$t_{50}$ CC	20	-	-	ns	$C_L=25\text{pF}$
Deviation from ideal duty cycle <sup>2)</sup>	$t_{500}$ CC	-2	-	$3.5+0.035 * C_L$	ns	$0 < C_L < 200\text{pF}$
MTSR delay from ASCLKO shifting edge	$t_{51}$ CC	-7	-	6	ns	$C_L=25\text{pF}$
ASLSON delay from the first ASCLKO edge	$t_{510}$ CC	-7	-	6	ns	$C_L=25\text{pF}$
MRST setup to ASCLKO latching edge	$t_{52}$ SR	30	-	-	ns	$C_L=25\text{pF}$ , else
		$33$ <sup>3)</sup>	-	-	ns	$C_L=25\text{pF}$ , for P14.2, P14.4, and P15.1
MRST hold from ASCLKO latching edge	$t_{53}$ SR	-5	-	-	ns	$C_L=25\text{pF}$

- 1) PLL Jitter not included. Should be considered additionally, corresponding to the used baudrate. The duty cycle can be adjusted using the BITCON.SAMPLEPOINT bitfield with the finest granularity of  $T_{MAX} = 1 / f_{MAX}$ .
- 2) Positive deviation lengthens the high time and shortens the low time of a clock period. Negative deviation does the opposite.
- 3) Please note that these pins didn't support the hystereses inactive feature.

**Table 3-48 Master Mode MPsm output pads**

Parameter	Symbol	Values			Unit	Note / Test Condition
		Min.	Typ.	Max.		
ASCLKO clock period <sup>1)</sup>	$t_{50}$ CC	100	-	-	ns	$C_L=50\text{pF}$
Deviation from ideal duty cycle <sup>2)</sup>	$t_{500}$ CC	-3	-	$4+0.04 * C_L$	ns	$0 < C_L < 200\text{pF}$
MTSR delay from ASCLKO shifting edge	$t_{51}$ CC	-11	-	10	ns	$C_L=50\text{pF}$
ASLSON delay from the first ASCLKO edge	$t_{510}$ CC	-11	-	10	ns	$C_L=50\text{pF}$
MRST setup to ASCLKO latching edge	$t_{52}$ SR	60	-	-	ns	$C_L=50\text{pF}$
MRST hold from ASCLKO latching edge	$t_{53}$ SR	-10	-	-	ns	$C_L=50\text{pF}$

- 1) PLL Jitter not included. Should be considered additionally, corresponding to the used baudrate. The duty cycle can be adjusted using the BITCON.SAMPLEPOINT bitfield with the finest granularity of  $T_{MAX} = 1 / f_{MAX}$ .
- 2) Positive deviation lengthens the high time and shortens the low time of a clock period. Negative deviation does the opposite.

**Electrical Specification ASCLIN SPI Master Timing**
**Table 3-49 Master Mode medium output pads**

Parameter	Symbol	Values			Unit	Note / Test Condition
		Min.	Typ.	Max.		
ASCLKO clock period <sup>1)</sup>	$t_{50}$ CC	200	-	-	ns	$C_L=50\text{pF}$
Deviation from ideal duty cycle <sup>2)</sup>	$t_{500}$ CC	-8	-	$4+0.04 * C_L$	ns	$0 < C_L < 200\text{pF}$
MTSR delay from ASCLKO shifting edge	$t_{51}$ CC	-20	-	15	ns	$C_L=50\text{pF}$
ASLSON delay from the first ASCLKO edge	$t_{510}$ CC	-20	-	20	ns	$C_L=50\text{pF}$
MRST setup to ASCLKO latching edge	$t_{52}$ SR	70	-	-	ns	$C_L=50\text{pF}$
MRST hold from ASCLKO latching edge	$t_{53}$ SR	-10	-	-	ns	$C_L=50\text{pF}$

- 1) PLL Jitter not included. Should be considered additionally, corresponding to the used baudrate. The duty cycle can be adjusted using the BITCON.SAMPLEPOINT bitfield with the finest granularity of  $T_{MAX} = 1 / f_{MAX}$ .
- 2) Positive deviation lengthens the high time and shortens the low time of a clock period. Negative deviation does the opposite.

**Table 3-50 Master Mode weak output pads**

Parameter	Symbol	Values			Unit	Note / Test Condition
		Min.	Typ.	Max.		
ASCLKO clock period <sup>1)</sup>	$t_{50}$ CC	1000	-	-	ns	$C_L=50\text{pF}$
Deviation from ideal duty cycle <sup>2)</sup>	$t_{500}$ CC	-30	-	$30+0.15 * C_L$	ns	$0 < C_L < 200\text{pF}$
MTSR delay from ASCLKO shifting edge	$t_{51}$ CC	-75	-	75	ns	$C_L=50\text{pF}$
ASLSON delay from the first ASCLKO edge	$t_{510}$ CC	-65	-	65	ns	$C_L=50\text{pF}$
MRST setup to ASCLKO latching edge	$t_{52}$ SR	510	-	-	ns	$C_L=50\text{pF}$
MRST hold from ASCLKO latching edge	$t_{53}$ SR	-50	-	-	ns	$C_L=50\text{pF}$

- 1) PLL Jitter not included. Should be considered additionally, corresponding to the used baudrate. The duty cycle can be adjusted using the BITCON.SAMPLEPOINT bitfield with the finest granularity of  $T_{MAX} = 1 / f_{MAX}$ .
- 2) Positive deviation lengthens the high time and shortens the low time of a clock period. Negative deviation does the opposite.

Electrical Specification ASCLIN SPI Master Timing

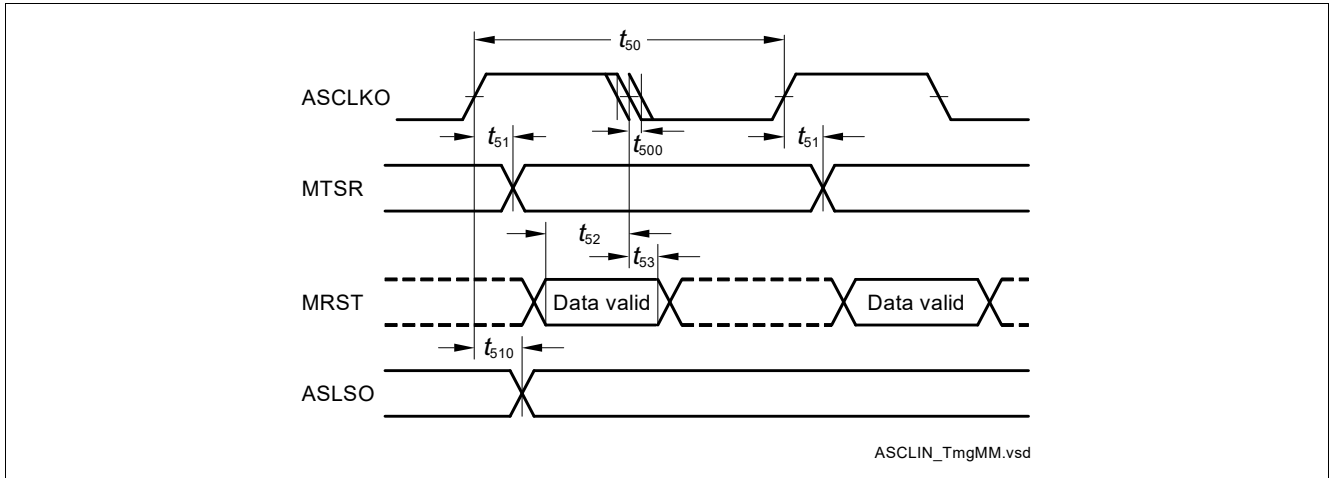

Figure 3-15 ASCLIN SPI Master Timing

### 3.24 ASCLIN SPI Master Timing

This section defines the timings for the ASCLIN in the TC270 / TC275 / TC277, for 3.3V power supply, Medium Performance pads, strong sharp edge (MPss),  $C_L=25\text{pF}$ .

*Note: Pad asymmetry is already included in the following timings.*

**Table 3-51 Master Mode MP+ss/MPRss output pads**

Parameter	Symbol	Values			Unit	Note / Test Condition
		Min.	Typ.	Max.		
ASCLKO clock period <sup>1)</sup>	$t_{50}$ CC	40	-	-	ns	$C_L=25\text{pF}$
Deviation from ideal duty cycle <sup>2)</sup>	$t_{500}$ CC	-5	-	5	ns	$0 < C_L < 50\text{pF}$
MTR delay from ASCLKO shifting edge	$t_{51}$ CC	-12	-	12	ns	$C_L=25\text{pF}$
ASLSON delay from the first ASCLKO edge	$t_{510}$ CC	0	-	60	ns	$C_L=25\text{pF}$ ; pad used = LPM
MRST setup to ASCLKO latching edge	$t_{52}$ SR	50	-	-	ns	$C_L=25\text{pF}$
MRST hold from ASCLKO latching edge	$t_{53}$ SR	-5	-	-	ns	$C_L=25\text{pF}$

1) PLL Jitter not included. Should be considered additionally, corresponding to the used baudrate. The duty cycle can be adjusted using the BITCON.SAMPLEPOINT bitfield with the finest granularity of  $T_{MAX} = 1 / f_{MAX}$ .

2) Positive deviation lengthens the high time and shortens the low time of a clock period. Negative deviation does the opposite.

**Table 3-52 Master Mode MP+sm/MPRsm output pads**

Parameter	Symbol	Values			Unit	Note / Test Condition
		Min.	Typ.	Max.		
ASCLKO clock period <sup>1)</sup>	$t_{50}$ CC	100	-	-	ns	$C_L=50\text{pF}$
Deviation from ideal duty cycle <sup>2)</sup>	$t_{500}$ CC	-3	-	7	ns	$0 < C_L < 200\text{pF}$
MTR delay from ASCLKO shifting edge	$t_{51}$ CC	-17	-	17	ns	$C_L=50\text{pF}$
ASLSON delay from the first ASCLKO edge	$t_{510}$ CC	0	-	60	ns	$C_L=50\text{pF}$ ; pad used = LPM
MRST setup to ASCLKO latching edge	$t_{52}$ SR	85	-	-	ns	$C_L=50\text{pF}$
MRST hold from ASCLKO latching edge	$t_{53}$ SR	-5	-	-	ns	$C_L=50\text{pF}$

1) PLL Jitter not included. Should be considered additionally, corresponding to the used baudrate. The duty cycle can be adjusted using the BITCON.SAMPLEPOINT bitfield with the finest granularity of  $T_{MAX} = 1 / f_{MAX}$ .

2) Positive deviation lengthens the high time and shortens the low time of a clock period. Negative deviation does the opposite.

**Electrical Specification ASCLIN SPI Master Timing**
**Table 3-53 Master Mode MPss output pads**

Parameter	Symbol	Values			Unit	Note / Test Condition
		Min.	Typ.	Max.		
ASCLKO clock period <sup>1)</sup>	$t_{50}$ CC	40	-	-	ns	$C_L=25\text{pF}$
Deviation from ideal duty cycle <sup>2)</sup>	$t_{500}$ CC	-5	-	$7+0.07 * C_L$	ns	$0 < C_L < 200\text{pF}$
MTSR delay from ASCLKO shifting edge	$t_{51}$ CC	-12	-	12	ns	$C_L=25\text{pF}$
ASLSON delay from the first ASCLKO edge	$t_{510}$ CC	-12	-	12	ns	$C_L=25\text{pF}$
MRST setup to ASCLKO latching edge	$t_{52}$ SR	50	-	-	ns	$C_L=25\text{pF}$
MRST hold from ASCLKO latching edge	$t_{53}$ SR	-5	-	-	ns	$C_L=25\text{pF}$

- 1) PLL Jitter not included. Should be considered additionally, corresponding to the used baudrate. The duty cycle can be adjusted using the BITCON.SAMPLEPOINT bitfield with the finest granularity of  $T_{MAX} = 1 / f_{MAX}$ .
- 2) Positive deviation lengthens the high time and shortens the low time of a clock period. Negative deviation does the opposite.

**Table 3-54 Master Mode MPsm output pads**

Parameter	Symbol	Values			Unit	Note / Test Condition
		Min.	Typ.	Max.		
ASCLKO clock period <sup>1)</sup>	$t_{50}$ CC	200	-	-	ns	$C_L=50\text{pF}$
Deviation from ideal duty cycle <sup>2)</sup>	$t_{500}$ CC	-5	-	$9+0.06 * C_L$	ns	$0 < C_L < 200\text{pF}$
MTSR delay from ASCLKO shifting edge	$t_{51}$ CC	-19	-	17	ns	$C_L=50\text{pF}$
ASLSON delay from the first ASCLKO edge	$t_{510}$ CC	-19	-	17	ns	$C_L=50\text{pF}$
MRST setup to ASCLKO latching edge	$t_{52}$ SR	100	-	-	ns	$C_L=50\text{pF}$
MRST hold from ASCLKO latching edge	$t_{53}$ SR	-13	-	-	ns	$C_L=50\text{pF}$

- 1) PLL Jitter not included. Should be considered additionally, corresponding to the used baudrate. The duty cycle can be adjusted using the BITCON.SAMPLEPOINT bitfield with the finest granularity of  $T_{MAX} = 1 / f_{MAX}$ .
- 2) Positive deviation lengthens the high time and shortens the low time of a clock period. Negative deviation does the opposite.

**Table 3-55 Master Mode medium output pads**

Parameter	Symbol	Values			Unit	Note / Test Condition
		Min.	Typ.	Max.		
ASCLKO clock period <sup>1)</sup>	$t_{50}$ CC	400	-	-	ns	$C_L=50\text{pF}$
Deviation from ideal duty cycle <sup>2)</sup>	$t_{500}$ CC	$-6-0.07 * C_L$	-	$6+0.07 * C_L$	ns	$0 < C_L < 200\text{pF}$

**Electrical Specification ASCLIN SPI Master Timing**
**Table 3-55 Master Mode medium output pads (cont'd)**

Parameter	Symbol	Values			Unit	Note / Test Condition
		Min.	Typ.	Max.		
MTSR delay from ASCLKO shifting edge	$t_{51}$ CC	-33	-	25	ns	$C_L=50\text{pF}$
ASLSON delay from the first ASCLKO edge	$t_{510}$ CC	-35	-	35	ns	$C_L=50\text{pF}$
MRST setup to ASCLKO latching edge	$t_{52}$ SR	120	-	-	ns	$C_L=50\text{pF}$
MRST hold from ASCLKO latching edge	$t_{53}$ SR	-13	-	-	ns	$C_L=50\text{pF}$

- 1) PLL Jitter not included. Should be considered additionally, corresponding to the used baudrate. The duty cycle can be adjusted using the BITCON.SAMPLEPOINT bitfield with the finest granularity of  $T_{MAX} = 1 / f_{MAX}$ .
- 2) Positive deviation lengthens the high time and shortens the low time of a clock period. Negative deviation does the opposite.

**Table 3-56 Master Mode weak output pads**

Parameter	Symbol	Values			Unit	Note / Test Condition
		Min.	Typ.	Max.		
ASCLKO clock period <sup>1)</sup>	$t_{50}$ CC	2000	-	-	ns	$C_L=50\text{pF}$
Deviation from ideal duty cycle <sup>2)</sup>	$t_{500}$ CC	-110	-	150	ns	$0 < C_L < 200\text{pF}$
MTSR delay from ASCLKO shifting edge	$t_{51}$ CC	-170	-	170	ns	$C_L=50\text{pF}$
ASLSON delay from the first ASCLKO edge	$t_{510}$ CC	-170	-	170	ns	$C_L=50\text{pF}$
MRST setup to ASCLKO latching edge	$t_{52}$ SR	510	-	-	ns	$C_L=50\text{pF}$
MRST hold from ASCLKO latching edge	$t_{53}$ SR	-40	-	-	ns	$C_L=50\text{pF}$

- 1) PLL Jitter not included. Should be considered additionally, corresponding to the used baudrate. The duty cycle can be adjusted using the BITCON.SAMPLEPOINT bitfield with the finest granularity of  $T_{MAX} = 1 / f_{MAX}$ .
- 2) Positive deviation lengthens the high time and shortens the low time of a clock period. Negative deviation does the opposite.

**Table 3-57 Master Mode A2ss output pads**

Parameter	Symbol	Values			Unit	Note / Test Condition
		Min.	Typ.	Max.		
ASCLKO clock period <sup>1)</sup>	$t_{50}$ CC	20	-	-	ns	$C_L=50\text{pF}$
Deviation from ideal duty cycle <sup>2)</sup>	$t_{500}$ CC	-3	-	3	ns	$C_L=50\text{pF}$
MTSR delay from ASCLKO shifting edge	$t_{51}$ CC	-4	-	4	ns	$C_L=50\text{pF}$
ASLSON delay from the first ASCLKO edge	$t_{510}$ CC	-5	-	4	ns	$C_L=50\text{pF}$

**Electrical Specification ASCLIN SPI Master Timing**
**Table 3-57 Master Mode A2ss output pads (cont'd)**

Parameter	Symbol	Values			Unit	Note / Test Condition
		Min.	Typ.	Max.		
MRST setup to ASCLKO latching edge	$t_{52}$ SR	17	-	-	ns	$C_L=50\text{pF}$
MRST hold from ASCLKO latching edge	$t_{53}$ SR	0	-	-	ns	$C_L=50\text{pF}$

- 1) PLL Jitter not included. Should be considered additionally, corresponding to the used baudrate. The duty cycle can be adjusted using the BITCON.SAMPLEPOINT bitfield with the finest granularity of  $T_{MAX} = 1 / f_{MAX}$ .
- 2) Positive deviation lengthens the high time and shortens the low time of a clock period. Negative deviation does the opposite.

**Table 3-58 Master Mode A2sm output pads**

Parameter	Symbol	Values			Unit	Note / Test Condition
		Min.	Typ.	Max.		
ASCLKO clock period <sup>1)</sup>	$t_{50}$ CC	40	-	-	ns	$C_L=50\text{pF}$
Deviation from ideal duty cycle <sup>2)</sup>	$t_{500}$ CC	-4	-	4	ns	$C_L=50\text{pF}$
MSTR delay from ASCLKO shifting edge	$t_{51}$ CC	-8	-	6	ns	$C_L=50\text{pF}$
ASLSON delay from the first ASCLKO edge	$t_{510}$ CC	-8	-	9	ns	$C_L=50\text{pF}$
MRST setup to ASCLKO latching edge	$t_{52}$ SR	26	-	-	ns	$C_L=50\text{pF}$
MRST hold from ASCLKO latching edge	$t_{53}$ SR	0	-	-	ns	$C_L=50\text{pF}$

- 1) PLL Jitter not included. Should be considered additionally, corresponding to the used baudrate. The duty cycle can be adjusted using the BITCON.SAMPLEPOINT bitfield with the finest granularity of  $T_{MAX} = 1 / f_{MAX}$ .
- 2) Positive deviation lengthens the high time and shortens the low time of a clock period. Negative deviation does the opposite.

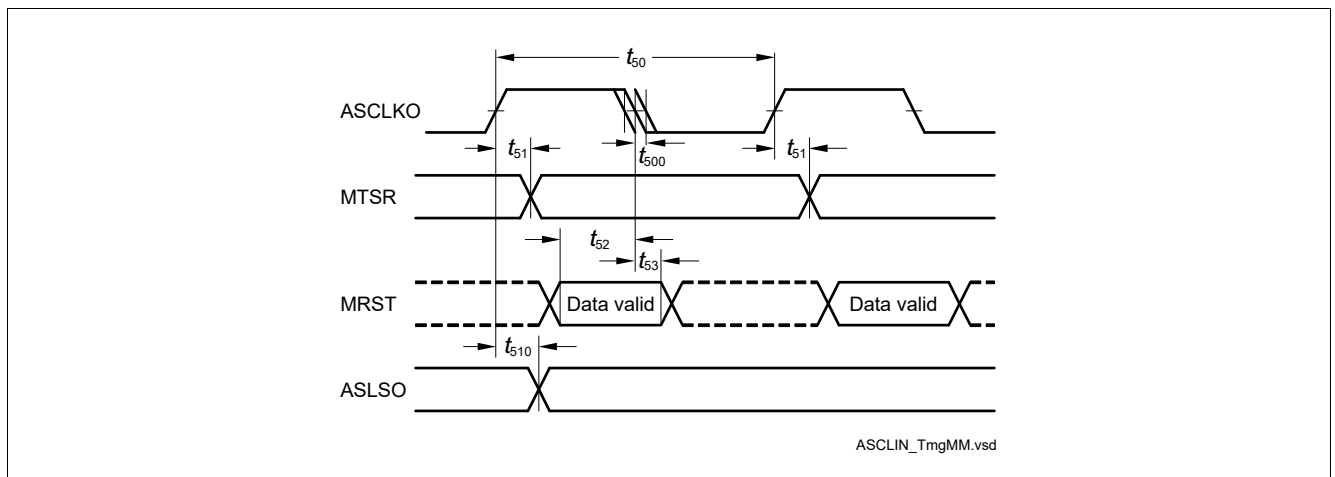
**Figure 3-16 ASCLIN SPI Master Timing**

### 3.25 QSPI Timings, Master and Slave Mode

This section defines the timings for the QSPI in the TC270 / TC275 / TC277, for 5V pad power supply. It is assumed that SCLKO, MTSR, and SLSO pads have the same pad settings:

- LVDSM output pads, LVDSH input pad, master mode,  $C_L=25\text{pF}$
- Medium Performance Plus Pads (MP+):
  - strong sharp edge (MP+ss),  $C_L=25\text{pF}$
  - strong medium edge (MP+sm),  $C_L=50\text{pF}$
  - medium edge (MP+m),  $C_L=50\text{pF}$
  - weak edge (MP+w),  $C_L=50\text{pF}$
- Medium Performance Pads (MP):
  - strong sharp edge (MPss),  $C_L=25\text{pF}$
  - strong medium edge (MPsm),  $C_L=50\text{pF}$
- Medium and Low Performance Pads (MP/LP), the identical output strength settings:
  - medium edge (LP/MPm),  $C_L=50\text{pF}$
  - weak edge (MPw),  $C_L=50\text{pF}$

*Note: Pad asymmetry is already included in the following timings.*

**Table 3-59 Master Mode Timing, LVDSM output pads for data and clock**

Parameter	Symbol	Values			Unit	Note / Test Condition
		Min.	Typ.	Max.		
SCLKO clock period <sup>1)</sup>	$t_{50}$ CC	20 <sup>2)</sup>	-	-	ns	$C_L=25\text{pF}$
Deviation from the ideal duty cycle <sup>3) 4)</sup>	$t_{500}$ CC	-1	-	1	ns	$C_L=25\text{pF}$
MTSR delay from SCLKO shifting edge	$t_{51}$ CC	-3	-	3	ns	$C_L=25\text{pF}$
SLSO deviation from the ideal programmed position	$t_{510}$ CC	0	-	30	ns	$C_L=25\text{pF}$ ; MPsm
		-5	-	7	ns	$C_L=25\text{pF}$ ; MPss
		-4	-	7	ns	MP+ss; $C_L=25\text{pF}$
		-1	-	15	ns	MP+sm; $C_L=25\text{pF}$
MRST setup to SCLK latching edge <sup>5)</sup>	$t_{52}$ SR	19 <sup>5)</sup>	-	-	ns	$C_L=25\text{pF}$ ; LVDSM 5V output and LVDSH 3.3V input
MRST hold from SCLK latching edge	$t_{53}$ SR	-6 <sup>5)</sup>	-	-	ns	$C_L=25\text{pF}$ ; LVDSM 5V output and LVDSH 3.3V input

- 1) Documented value is valid for master transmit or slave receive only. For full duplex the external SPI counterpart timing has to be taken into account.
- 2) The capacitive load on the LVDS pins is differential, the capacitive load on the CMOS pins is single ended.
- 3) The PLL jitter is not included. It should be considered additionally, corresponding to the used baudrate. The duty cycle can be adjusted using the bit fields ECONZ.A, B and C with the finest granularity of  $T_{MAX} = 1 / f_{MAX}$ .
- 4) Positive deviation lengthens the high time and shortens the low time of a clock period. Negative deviation does the opposite.
- 5) For compensation of the average on-chip delay the QSPI module provides the bit fields ECONZ.A, B and C.

**Electrical Specification QSPI Timings, Master and Slave Mode**
**Table 3-60 Master Mode MP+ss/MPRss output pads**

Parameter	Symbol	Values			Unit	Note / Test Condition
		Min.	Typ.	Max.		
SCLKO clock period <sup>1)</sup>	$t_{50}$ CC	20	-	-	ns	$C_L=25\text{pF}$
Deviation from the ideal duty cycle <sup>2) 3)</sup>	$t_{500}$ CC	-3	-	3	ns	$0 < C_L < 50\text{pF}$
MISR delay from SCLKO shifting edge	$t_{51}$ CC	-7	-	6	ns	$C_L=25\text{pF}$
SLSON deviation from the ideal programmed position	$t_{510}$ CC	-7	-	6	ns	$C_L=25\text{pF}$
MRST setup to SCLK latching edge <sup>4)</sup>	$t_{52}$ SR	27 <sup>4)5)</sup>	-	-	ns	$C_L=25\text{pF}$
MRST hold from SCLK latching edge	$t_{53}$ SR	-6 <sup>4)5)</sup>	-	-	ns	$C_L=25\text{pF}$

- 1) Documented value is valid for master transmit or slave receive only. For full duplex the external SPI counterpart timing has to be taken into account.
- 2) The PLL jitter is not included. It should be considered additionally, corresponding to the used baudrate. The duty cycle can be adjusted using the bit fields ECONz.A, B and C with the finest granularity of  $T_{MAX} = 1 / f_{MAX}$ .
- 3) Positive deviation lengthens the high time and shortens the low time of a clock period. Negative deviation does the opposite.
- 4) For compensation of the average on-chip delay the QSPI module provides the bit fields ECONz.A, B and C.
- 5) The setup and hold times are valid for both settings of the input pads thresholds: TTL and AL.

**Table 3-61 Master Mode MP+sm/MPRsm output pads for data and clock**

Parameter	Symbol	Values			Unit	Note / Test Condition
		Min.	Typ.	Max.		
SCLKO clock period <sup>1)</sup>	$t_{50}$ CC	50	-	-	ns	$C_L=50\text{pF}$
Deviation from the ideal duty cycle <sup>2) 3)</sup>	$t_{500}$ CC	-2	-	$3+0.01 \cdot C_L$ *	ns	$0 < C_L < 200\text{pF}$
MISR delay from SCLKO shifting edge	$t_{51}$ CC	-10	-	10	ns	$C_L=50\text{pF}$
SLSON deviation from the ideal programmed position	$t_{510}$ CC	-10	-	10	ns	MP+sm; $C_L=50\text{pF}$
		-13	-	1	ns	MPss; $C_L=50\text{pF}$
		0	-	40	ns	MP+m, MPm, LPM; $C_L=50\text{pF}$
MRST setup to SCLK latching edge <sup>4)</sup>	$t_{52}$ SR	50 <sup>4)5)</sup>	-	-	ns	$C_L=50\text{pF}$
MRST hold from SCLK latching edge	$t_{53}$ SR	-10 <sup>4)5)</sup>	-	-	ns	$C_L=50\text{pF}$

- 1) Documented value is valid for master transmit or slave receive only. For full duplex the external SPI counterpart timing has to be taken into account.
- 2) The PLL jitter is not included. It should be considered additionally, corresponding to the used baudrate. The duty cycle can be adjusted using the bit fields ECONz.A, B and C with the finest granularity of  $T_{MAX} = 1 / f_{MAX}$ .
- 3) Positive deviation lengthens the high time and shortens the low time of a clock period. Negative deviation does the opposite.

**Electrical Specification QSPI Timings, Master and Slave Mode**

- 4) For compensation of the average on-chip delay the QSPI module provides the bit fields ECONz.A, B and C.  
 5) The setup and hold times are valid for both settings of the input pads thresholds: TTL and AL.

**Table 3-62 Master Mode timing MPsm output pads**

Parameter	Symbol	Values			Unit	Note / Test Condition
		Min.	Typ.	Max.		
SCLKO clock period <sup>1)</sup>	$t_{50}$ CC	100	-	-	ns	$C_L=50\text{pF}$
Deviation from the ideal duty cycle <sup>2) 3)</sup>	$t_{500}$ CC	-3	-	$4+0.04 * C_L$	ns	$0 < C_L < 200\text{pF}$
MTSR delay from SCLKO shifting edge	$t_{51}$ CC	-11	-	10	ns	$C_L=50\text{pF}$
SLSON deviation from the ideal programmed position	$t_{510}$ CC	-11	-	10	ns	$C_L=50\text{pF}$
MRST setup to SCLK latching edge <sup>4)</sup>	$t_{52}$ SR	$60^{4)5)}$	-	-	ns	$C_L=50\text{pF}$
MRST hold from SCLK latching edge	$t_{53}$ SR	$-10^{4)5)}$	-	-	ns	$C_L=50\text{pF}$

- 1) Documented value is valid for master transmit or slave receive only. For full duplex the external SPI counterpart timing has to be taken into account.  
 2) The PLL jitter is not included. It should be considered additionally, corresponding to the used baudrate. The duty cycle can be adjusted using the bit fields ECONz.A, B and C with the finest granularity of  $T_{MAX} = 1 / f_{MAX}$ .  
 3) Positive deviation lengthens the high time and shortens the low time of a clock period. Negative deviation does the opposite.  
 4) For compensation of the average on-chip delay the QSPI module provides the bit fields ECONz.A, B and C.  
 5) The setup and hold times are valid for both settings of the input pads thresholds: TTL and AL.

**Table 3-63 Master Mode timing MPRm/MP+m/MPm/LPm output pads**

Parameter	Symbol	Values			Unit	Note / Test Condition
		Min.	Typ.	Max.		
SCLKO clock period <sup>1)</sup>	$t_{50}$ CC	200	-	-	ns	$C_L=50\text{pF}$
Deviation from the ideal duty cycle <sup>2) 3)</sup>	$t_{500}$ CC	-10	-	$10+0.04 * C_L$	ns	$0 < C_L < 200\text{pF}$
MTSR delay from SCLKO shifting edge	$t_{51}$ CC	-15	-	19	ns	$C_L=50\text{pF}$
SLSON deviation from the ideal programmed position	$t_{510}$ CC	-20	-	20	ns	$C_L=50\text{pF}$
MRST setup to SCLK latching edge <sup>4)</sup>	$t_{52}$ SR	$70^{4)5)}$	-	-	ns	$C_L=50\text{pF}$
MRST hold from SCLK latching edge	$t_{53}$ SR	$-10^{4)5)}$	-	-	ns	$C_L=50\text{pF}$

- 1) Documented value is valid for master transmit or slave receive only. For full duplex the external SPI counterpart timing has to be taken into account.  
 2) The PLL jitter is not included. It should be considered additionally, corresponding to the used baudrate. The duty cycle can be adjusted using the bit fields ECONz.A, B and C with the finest granularity of  $T_{MAX} = 1 / f_{MAX}$ .  
 3) Positive deviation lengthens the high time and shortens the low time of a clock period. Negative deviation does the opposite.

**Electrical Specification QSPI Timings, Master and Slave Mode**

- 4) For compensation of the average on-chip delay the QSPI module provides the bit fields ECONz.A, B and C.  
 5) The setup and hold times are valid for both settings of the input pads thresholds: TTL and AL.

**Table 3-64 Master Mode Weak output pads**

Parameter	Symbol	Values			Unit	Note / Test Condition
		Min.	Typ.	Max.		
SCLKO clock period <sup>1)</sup>	$t_{50}$ CC	1000	-	-	ns	$C_L=50\text{pF}$
Deviation from the ideal duty cycle <sup>2) 3)</sup>	$t_{500}$ CC	-30	-	$30+0.15 * C_L$	ns	$0 < C_L < 200\text{pF}$
MTSR delay from SCLKO shifting edge	$t_{51}$ CC	-65	-	65	ns	$C_L=50\text{pF}$
SLSON deviation from the ideal programmed position	$t_{510}$ CC	-70	-	65	ns	$C_L=50\text{pF}$
MRST setup to SCLK latching edge <sup>4)</sup>	$t_{52}$ SR	300 <sup>4)5)</sup>	-	-	ns	$C_L=50\text{pF}$
MRST hold from SCLK latching edge	$t_{53}$ SR	-40 <sup>4)5)</sup>	-	-	ns	$C_L=50\text{pF}$

- 1) Documented value is valid for master transmit or slave receive only. For full duplex the external SPI counterpart timing has to be taken into account.  
 2) The PLL jitter is not included. It should be considered additionally, corresponding to the used baudrate. The duty cycle can be adjusted using the bit fields ECONz.A, B and C with the finest granularity of  $T_{MAX} = 1 / f_{MAX}$ .  
 3) Positive deviation lengthens the high time and shortens the low time of a clock period. Negative deviation does the opposite.  
 4) For compensation of the average on-chip delay the QSPI module provides the bit fields ECONz.A, B and C.  
 5) The setup and hold times are valid for both settings of the input pads thresholds: TTL and AL.

**Table 3-65 Slave mode timing**

Parameter	Symbol	Values			Unit	Note / Test Condition
		Min.	Typ.	Max.		
SCLK clock period	$t_{54}$ SR	$4 \times T_{MAX}$	-	-	ns	
SCLK duty cycle	$t_{55/t54}$ SR	40	-	60	%	
MTSR setup to SCLK latching edge	$t_{56}$ SR	4 <sup>1)</sup>	-	-	ns	Hysteresis Inactive
		5 <sup>1)</sup>	-	-	ns	Input Level AL
		5 <sup>1)</sup>	-	-	ns	Input Level TTL
MTSR hold from SCLK latching edge	$t_{57}$ SR	3 <sup>1)</sup>	-	-	ns	Hysteresis Inactive
		6 <sup>1)</sup>	-	-	ns	Input Level AL
		9 <sup>1)</sup>	-	-	ns	Input Level TTL
SLSI setup to first SCLK shift edge	$t_{58}$ SR	5 <sup>1)</sup>	-	-	ns	Hysteresis Inactive
		4 <sup>1)</sup>	-	-	ns	Input Level AL
		8 <sup>1)</sup>	-	-	ns	Input Level TTL
		6	-	-	ns	Only for pin 15.1, AL

Electrical Specification QSPI Timings, Master and Slave Mode

Table 3-65 Slave mode timing (cont'd)

Parameter	Symbol	Values			Unit	Note / Test Condition
		Min.	Typ.	Max.		
SLSI hold from last SCLK latching edge	$t_{59}$ SR	3 <sup>1)</sup>	-	-	ns	Hysteresis Inactive
		4 <sup>1)</sup>	-	-	ns	Input Level AL
		8 <sup>1)</sup>	-	-	ns	Input Level TTL
MRST delay from SCLK shift edge	$t_{60}$ CC	10	-	70	ns	MP+m/MPRm; $C_L=50\text{pF}$
		10	-	50	ns	MP+sm/MPRsm; $C_L=50\text{pF}$
		5	-	30	ns	MP+ss/MPRss; $C_L=25\text{pF}$
		40	-	300	ns	MP+w/MPRw; $C_L=50\text{pF}$
		10	-	70	ns	MPm/LPm; $C_L=50\text{pF}$
		10	-	55	ns	MPsm; $C_L=50\text{pF}$
		5	-	30	ns	MPss; $C_L=25\text{pF}$
		40	-	300	ns	MPw/LPw; $C_L=50\text{pF}$
SLSI to valid data on MRST	$t_{61}$ SR	-	-	5	ns	

1) Except pin P15.1.

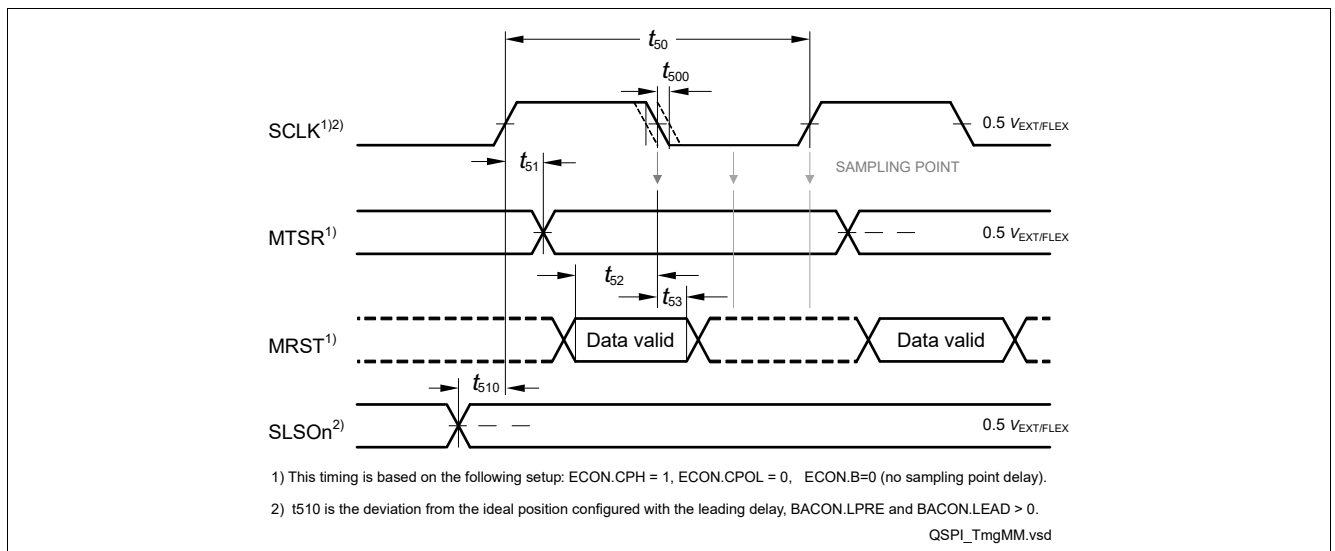

Figure 3-17 Master Mode Timing

Electrical Specification QSPI Timings, Master and Slave Mode

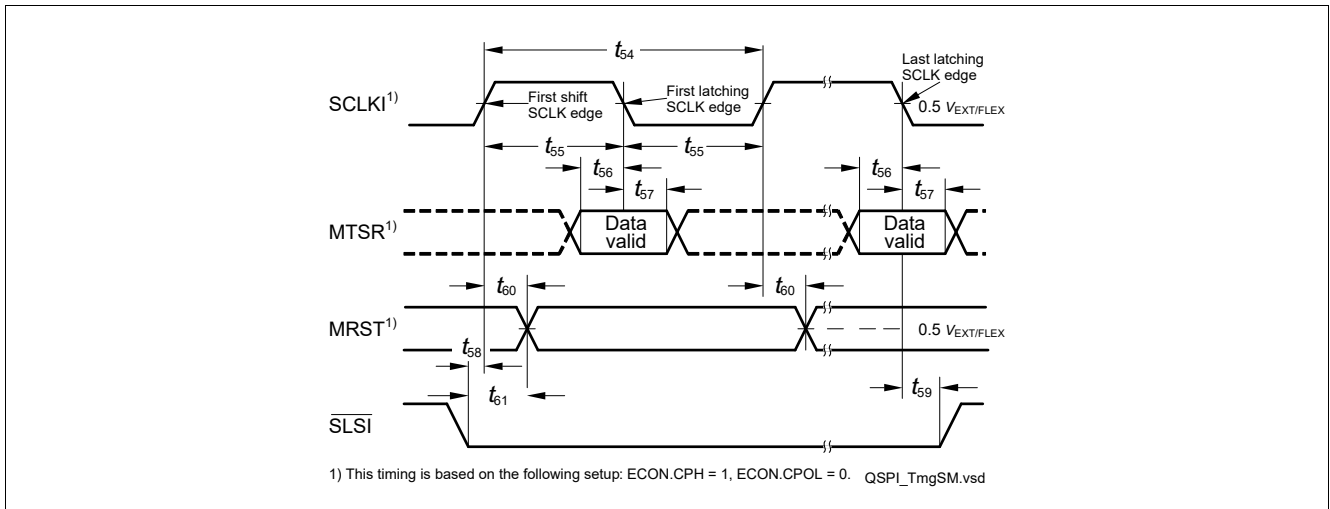

Figure 3-18 Slave Mode Timing

### 3.26 QSPI Timings, Master and Slave Mode

This section defines the timings for the QSPI in the TC270 / TC275 / TC277, for 3.3V pad power supply. It is assumed that SCLKO, MTSR, and SLSO pads have the same pad settings:

- LVDSM output pads, LVDSH input pad, master mode,  $C_L=25\text{pF}$
- Medium Performance Plus Pads (MP+):
  - strong sharp edge (MP+ss),  $C_L=25\text{pF}$
  - strong medium edge (MP+sm),  $C_L=50\text{pF}$
  - medium edge (MP+m),  $C_L=50\text{pF}$
  - weak edge (MP+w),  $C_L=50\text{pF}$
- Medium Performance Pads (MP):
  - strong sharp edge (MPss),  $C_L=25\text{pF}$
  - strong medium edge (MPsm),  $C_L=50\text{pF}$
- Medium and Low Performance Pads (MP/LP), the identical output strength settings:
  - medium edge (LP/MPm),  $C_L=50\text{pF}$
  - weak edge (MPw),  $C_L=50\text{pF}$

Note: Pad asymmetry is already included in the following timings.

Table 3-66 Master Mode Timing, LVDSM output pads for data and clock

Parameter	Symbol	Values			Unit	Note / Test Condition
		Min.	Typ.	Max.		
SCLKO clock period <sup>1)</sup>	$t_{50}$ CC	20	-	-	ns	$C_L=25\text{pF}$
Deviation from the ideal duty cycle <sup>2) 3)</sup>	$t_{500}$ CC	-2	-	2	ns	$C_L=25\text{pF}$
MTSR delay from SCLKO shifting edge	$t_{51}$ CC	-5	-	5	ns	$C_L=25\text{pF}$

**Electrical Specification QSPI Timings, Master and Slave Mode**
**Table 3-66 Master Mode Timing, LVDSM output pads for data and clock (cont'd)**

Parameter	Symbol	Values			Unit	Note / Test Condition
		Min.	Typ.	Max.		
SLSON deviation from the ideal programmed position	$t_{510}$ CC	-2	-	55	ns	$C_L=25\text{pF}$ ; MPsm
		-9	-	12	ns	$C_L=25\text{pF}$ ; MPss
		-7	-	12	ns	MP+ss; $C_L=25\text{pF}$
		-2	-	26	ns	MP+sm; $C_L=25\text{pF}$
MRST setup to SCLK latching edge <sup>4)</sup>	$t_{52}$ SR	20	-	-	ns	$C_L=25\text{pF}$ ; LVDSM 5V output and LVDSH 3.3V input
MRST hold from SCLK latching edge	$t_{53}$ SR	-6	-	-	ns	$C_L=25\text{pF}$ ; LVDSM 5V output and LVDSH 3.3V input

- 1) Documented value is valid for master transmit or slave receive only. For full duplex the external SPI counterpart timing has to be taken into account.
- 2) The PLL jitter is not included. It should be considered additionally, corresponding to the used baudrate. The duty cycle can be adjusted using the bit fields ECONZ.A, B and C with the finest granularity of  $T_{MAX} = 1 / f_{MAX}$ .
- 3) Positive deviation lengthens the high time and shortens the low time of a clock period. Negative deviation does the opposite.
- 4) For compensation of the average on-chip delay the QSPI module provides the bit fields ECONZ.A, B and C.

**Table 3-67 Master Mode MP+ss/MPRss output pads**

Parameter	Symbol	Values			Unit	Note / Test Condition
		Min.	Typ.	Max.		
SCLKO clock period <sup>1)</sup>	$t_{50}$ CC	40	-	-	ns	$C_L=25\text{pF}$
Deviation from the ideal duty cycle <sup>2) 3)</sup>	$t_{500}$ CC	-5	-	5	ns	$0 < C_L < 50\text{pF}$
MISR delay from SCLKO shifting edge	$t_{51}$ CC	-12	-	12	ns	$C_L=25\text{pF}$
SLSON deviation from the ideal programmed position	$t_{510}$ CC	-12	-	12	ns	$C_L=25\text{pF}$
MRST setup to SCLK latching edge <sup>4)</sup>	$t_{52}$ SR	50 <sup>4)5)</sup>	-	-	ns	$C_L=25\text{pF}$
MRST hold from SCLK latching edge	$t_{53}$ SR	-6 <sup>4)5)</sup>	-	-	ns	$C_L=25\text{pF}$

- 1) Documented value is valid for master transmit or slave receive only. For full duplex the external SPI counterpart timing has to be taken into account.
- 2) The PLL jitter is not included. It should be considered additionally, corresponding to the used baudrate. The duty cycle can be adjusted using the bit fields ECONZ.A, B and C with the finest granularity of  $T_{MAX} = 1 / f_{MAX}$ .
- 3) Positive deviation lengthens the high time and shortens the low time of a clock period. Negative deviation does the opposite.
- 4) For compensation of the average on-chip delay the QSPI module provides the bit fields ECONZ.A, B and C.
- 5) The setup and hold times are valid for both settings of the input pads thresholds: TTL and AL.

**Electrical Specification QSPI Timings, Master and Slave Mode**
**Table 3-68 Master Mode MP+sm/MPRsm output pads for data and clock**

Parameter	Symbol	Values			Unit	Note / Test Condition
		Min.	Typ.	Max.		
SCLKO clock period <sup>1)</sup>	$t_{50}$ CC	100	-	-	ns	$C_L=50\text{pF}$
Deviation from the ideal duty cycle <sup>2) 3)</sup>	$t_{500}$ CC	-3	-	7	ns	$0 < C_L < 200\text{pF}$
MtSR delay from SCLKO shifting edge	$t_{51}$ CC	-17	-	17	ns	$C_L=50\text{pF}$
SLSON deviation from the ideal programmed position	$t_{510}$ CC	-17	-	17	ns	MP+sm; $C_L=50\text{pF}$
		-22	-	2	ns	MPss; $C_L=50\text{pF}$
		0	-	70	ns	MP+m; MPm; LPm; $C_L=50\text{pF}$
MRST setup to SCLK latching edge <sup>4)</sup>	$t_{52}$ SR	85 <sup>4)5)</sup>	-	-	ns	$C_L=50\text{pF}$
MRST hold from SCLK latching edge	$t_{53}$ SR	-10 <sup>4)5)</sup>	-	-	ns	$C_L=50\text{pF}$

- 1) Documented value is valid for master transmit or slave receive only. For full duplex the external SPI counterpart timing has to be taken into account.
- 2) The PLL jitter is not included. It should be considered additionally, corresponding to the used baudrate. The duty cycle can be adjusted using the bit fields ECONz.A, B and C with the finest granularity of  $T_{MAX} = 1 / f_{MAX}$ .
- 3) Positive deviation lengthens the high time and shortens the low time of a clock period. Negative deviation does the opposite.
- 4) For compensation of the average on-chip delay the QSPI module provides the bit fields ECONz.A, B and C.
- 5) The setup and hold times are valid for both settings of the input pads thresholds: TTL and AL.

**Table 3-69 Master Mode timing MPss output pads**

Parameter	Symbol	Values			Unit	Note / Test Condition
		Min.	Typ.	Max.		
SCLKO clock period <sup>1)</sup>	$t_{50}$ CC	40	-	-	ns	$C_L=25\text{pF}$
Deviation from the ideal duty cycle <sup>2) 3)</sup>	$t_{500}$ CC	-5	-	$7+0.07 \cdot C_L$ *	ns	$C_L=25\text{pF}$
MtSR delay from SCLKO shifting edge	$t_{51}$ CC	-10	-	10	ns	$C_L=25\text{pF}$
SLSON deviation from the ideal programmed position	$t_{510}$ CC	-10	-	10	ns	$C_L=25\text{pF}$
MRST setup to SCLK latching edge <sup>4)</sup>	$t_{52}$ SR	50 <sup>4)5)</sup>	-	-	ns	$C_L=25\text{pF}$
MRST hold from SCLK latching edge	$t_{53}$ SR	-6 <sup>4)5)</sup>	-	-	ns	$C_L=25\text{pF}$

- 1) Documented value is valid for master transmit or slave receive only. For full duplex the external SPI counterpart timing has to be taken into account.
- 2) The PLL jitter is not included. It should be considered additionally, corresponding to the used baudrate. The duty cycle can be adjusted using the bit fields ECONz.A, B and C with the finest granularity of  $T_{MAX} = 1 / f_{MAX}$ .
- 3) Positive deviation lengthens the high time and shortens the low time of a clock period. Negative deviation does the opposite.

**Electrical Specification QSPI Timings, Master and Slave Mode**

- 4) For compensation of the average on-chip delay the QSPI module provides the bit fields ECONz.A, B and C.  
 5) The setup and hold times are valid for both settings of the input pads thresholds: TTL and AL.

**Table 3-70 Master Mode timing MPsm output pads**

Parameter	Symbol	Values			Unit	Note / Test Condition
		Min.	Typ.	Max.		
SCLKO clock period <sup>1)</sup>	$t_{50}$ CC	200	-	-	ns	$C_L=50\text{pF}$
Deviation from the ideal duty cycle <sup>2) 3)</sup>	$t_{500}$ CC	-5	-	$9+0.06 \cdot C_L$	ns	$0 < C_L < 200\text{pF}$
MTSR delay from SCLKO shifting edge	$t_{51}$ CC	-19	-	19	ns	$C_L=50\text{pF}$
SLSON deviation from the ideal programmed position	$t_{510}$ CC	-19	-	17	ns	$C_L=50\text{pF}$
MRST setup to SCLK latching edge <sup>4)</sup>	$t_{52}$ SR	100 <sup>4)5)</sup>	-	-	ns	$C_L=50\text{pF}$
MRST hold from SCLK latching edge	$t_{53}$ SR	-13 <sup>4)5)</sup>	-	-	ns	$C_L=50\text{pF}$

- 1) Documented value is valid for master transmit or slave receive only. For full duplex the external SPI counterpart timing has to be taken into account.  
 2) The PLL jitter is not included. It should be considered additionally, corresponding to the used baudrate. The duty cycle can be adjusted using the bit fields ECONz.A, B and C with the finest granularity of  $T_{MAX} = 1 / f_{MAX}$ .  
 3) Positive deviation lengthens the high time and shortens the low time of a clock period. Negative deviation does the opposite.  
 4) For compensation of the average on-chip delay the QSPI module provides the bit fields ECONz.A, B and C.  
 5) The setup and hold times are valid for both settings of the input pads thresholds: TTL and AL.

**Table 3-71 Master Mode timing MPRm/MP+m/MPm/LPm output pads**

Parameter	Symbol	Values			Unit	Note / Test Condition
		Min.	Typ.	Max.		
SCLKO clock period <sup>1)</sup>	$t_{50}$ CC	400	-	-	ns	$C_L=50\text{pF}$
Deviation from the ideal duty cycle <sup>2) 3)</sup>	$t_{500}$ CC	$-6-0.07 \cdot C_L$	-	$6+0.07 \cdot C_L$	ns	$0 < C_L < 200\text{pF}$
MTSR delay from SCLKO shifting edge	$t_{51}$ CC	-25	-	33	ns	$C_L=50\text{pF}$
SLSON deviation from the ideal programmed position	$t_{510}$ CC	-35	-	35	ns	$C_L=50\text{pF}$
MRST setup to SCLK latching edge <sup>4)</sup>	$t_{52}$ SR	120 <sup>4)5)</sup>	-	-	ns	$C_L=50\text{pF}$
MRST hold from SCLK latching edge	$t_{53}$ SR	-13 <sup>4)5)</sup>	-	-	ns	$C_L=50\text{pF}$

- 1) Documented value is valid for master transmit or slave receive only. For full duplex the external SPI counterpart timing has to be taken into account.  
 2) The PLL jitter is not included. It should be considered additionally, corresponding to the used baudrate. The duty cycle can be adjusted using the bit fields ECONz.A, B and C with the finest granularity of  $T_{MAX} = 1 / f_{MAX}$ .  
 3) Positive deviation lengthens the high time and shortens the low time of a clock period. Negative deviation does the opposite.

**Electrical Specification QSPI Timings, Master and Slave Mode**

- 4) For compensation of the average on-chip delay the QSPI module provides the bit fields ECONz.A, B and C.  
 5) The setup and hold times are valid for both settings of the input pads thresholds: TTL and AL.

**Table 3-72 Master Mode Weak output pads**

Parameter	Symbol	Values			Unit	Note / Test Condition
		Min.	Typ.	Max.		
SCLKO clock period <sup>1)</sup>	$t_{50}$ CC	2000	-	-	ns	$C_L=50\text{pF}$
Deviation from the ideal duty cycle <sup>2) 3)</sup>	$t_{500}$ CC	-110	-	110	ns	$0 < C_L < 200\text{pF}$
MTSR delay from SCLKO shifting edge	$t_{51}$ CC	-170	-	170	ns	$C_L=50\text{pF}$
SLSON deviation from the ideal programmed position	$t_{510}$ CC	-170	-	170	ns	$C_L=50\text{pF}$
MRST setup to SCLK latching edge <sup>4)</sup>	$t_{52}$ SR	510 <sup>4)5)</sup>	-	-	ns	$C_L=50\text{pF}$
MRST hold from SCLK latching edge	$t_{53}$ SR	-40 <sup>4)5)</sup>	-	-	ns	$C_L=50\text{pF}$

- 1) Documented value is valid for master transmit or slave receive only. For full duplex the external SPI counterpart timing has to be taken into account.  
 2) The PLL jitter is not included. It should be considered additionally, corresponding to the used baudrate. The duty cycle can be adjusted using the bit fields ECONz.A, B and C with the finest granularity of  $T_{MAX} = 1 / f_{MAX}$ .  
 3) Positive deviation lengthens the high time and shortens the low time of a clock period. Negative deviation does the opposite.  
 4) For compensation of the average on-chip delay the QSPI module provides the bit fields ECONz.A, B and C.  
 5) The setup and hold times are valid for both settings of the input pads thresholds: TTL and AL.

**Table 3-73 Slave mode timing**

Parameter	Symbol	Values			Unit	Note / Test Condition
		Min.	Typ.	Max.		
SCLK clock period	$t_{54}$ SR	$4 \times T_{MAX}$	-	-	ns	
SCLK duty cycle	$t_{55/t54}$ SR	40	-	60	%	
MTSR setup to SCLK latching edge	$t_{56}$ SR	7 <sup>1)</sup>	-	-	ns	Hysteresis inactive
		9 <sup>1)</sup>	-	-	ns	Input Level AL
		7 <sup>1)</sup>	-	-	ns	Input Level TTL
MTSR hold from SCLK latching edge	$t_{57}$ SR	5 <sup>1)</sup>	-	-	ns	Hysteresis inactive
		11 <sup>1)</sup>	-	-	ns	Input Level AL
		16 <sup>1)</sup>	-	-	ns	Input Level TTL
SLSI setup to first SCLK shift edge	$t_{58}$ SR	7 <sup>1)</sup>	-	-	ns	Hysteresis inactive
		7 <sup>1)</sup>	-	-	ns	Input Level AL
		14 <sup>1)</sup>	-	-	ns	Input Level TTL
		11	-	-	ns	Only for pin P15.1, AL

Electrical Specification QSPI Timings, Master and Slave Mode

Table 3-73 Slave mode timing (cont'd)

Parameter	Symbol	Values			Unit	Note / Test Condition
		Min.	Typ.	Max.		
SLSI hold from last SCLK latching edge	$t_{59}$ SR	5 <sup>1)</sup>	-	-	ns	Hysteresis inactive
		7 <sup>1)</sup>	-	-	ns	Input Level AL
		14 <sup>1)</sup>	-	-	ns	Input Level TTL
MRST delay from SCLK shift edge	$t_{60}$ CC	13	-	120	ns	MP+m/MPRm; $C_L=50\text{pF}$
		13	-	85	ns	MP+sm/MPRsm; $C_L=50\text{pF}$
		6	-	50	ns	MP+ss/MPRss; $C_L=25\text{pF}$
		70	-	500	ns	MP+w/MPRw; $C_L=50\text{pF}$
		13	-	120	ns	MPm/LPm; $C_L=50\text{pF}$
		13	-	100	ns	MPsm; $C_L=50\text{pF}$
		6	-	52	ns	MPss; $C_L=25\text{pF}$
		70	-	500	ns	MPw/LPw; $C_L=50\text{pF}$
SLSI to valid data on MRST	$t_{61}$ SR	-	-	9	ns	

1) Except pin P15.1

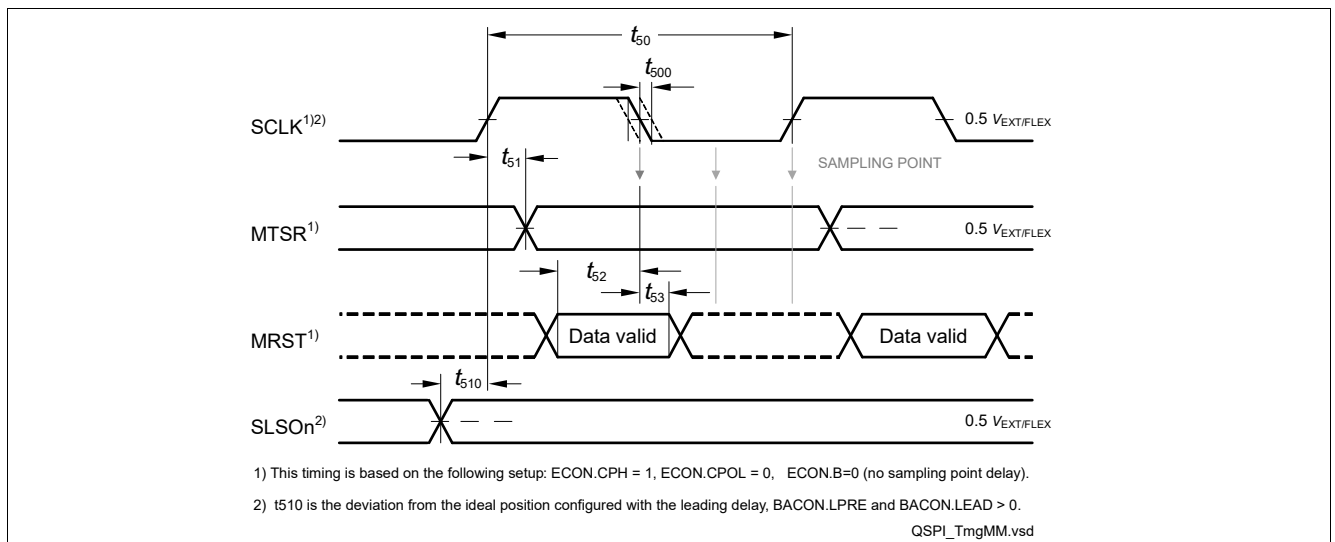

Figure 3-19 Master Mode Timing

Electrical Specification QSPI Timings, Master and Slave Mode

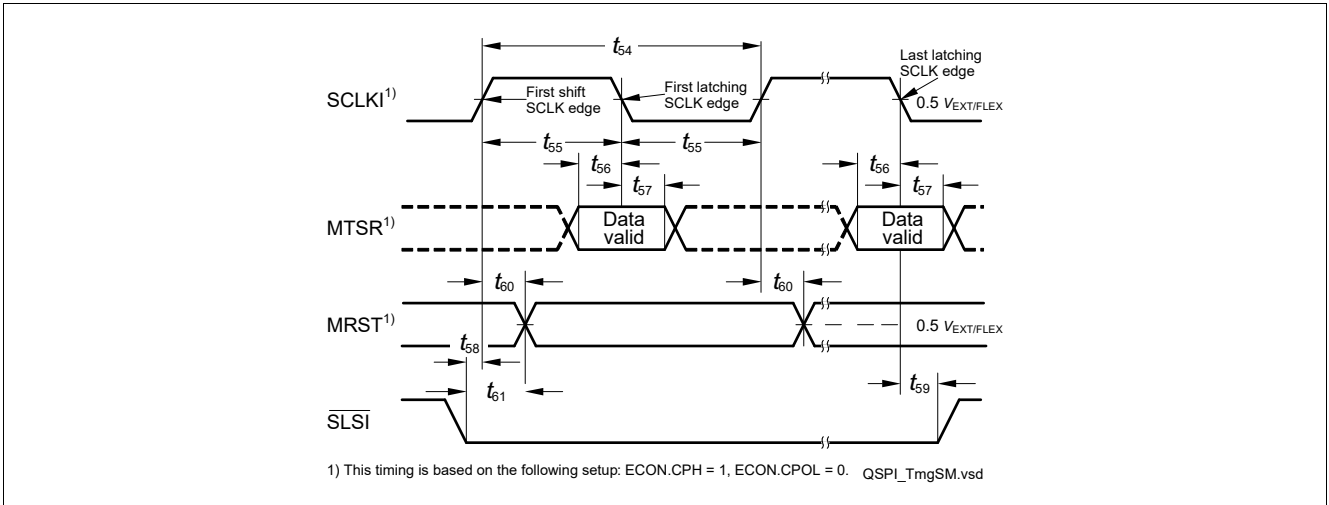

Figure 3-20 Slave Mode Timing

### 3.27 MSC Timing 5 V Operation

The following section defines the timings for 5V pad power supply.

Note: Pad asymmetry is already included in the following timings.

Note: Load for LVDS pads are defined as differential loads in the following timings.

**Table 3-74 LVDS clock/data (LVDS pads in LVDS mode)**

Parameter	Symbol	Values			Unit	Note / Test Condition
		Min.	Typ.	Max.		
FCLPx clock period <sup>1)</sup>	$t_{40}$ CC	$2 * T_A$ <sup>2) 3)</sup>	-	-	ns	LVDSM; $C_L=50\text{pF}$
Deviation from ideal duty cycle <sup>4) 5)</sup>	$t_{400}$ CC	-1	-	1	ns	LVDSM; $0 < C_L < 50\text{pF}$
SOPx output delay <sup>6)</sup>	$t_{44}$ CC	-3	-	4	ns	LVDSM; $C_L=50\text{pF}$ ; option EN01
		-4	-	4.5	ns	LVDSM; $C_L=50\text{pF}$ ; option EN01D
ENx output delay <sup>6)</sup>	$t_{45}$ CC	-4	-	5	ns	MP+ss/MPRss; option EN01; $C_L=25\text{pF}$
		-3	-	7	ns	MP+ss/MPRss; option EN01; $C_L=50\text{pF}$
		-3	-	11	ns	MP+sm/MPRsm; option EN01D; $C_L=50\text{pF}$
		-2	-	9	ns	MP+ss/MPRss; option EN23; $C_L=25\text{pF}$
		-2	-	11	ns	MP+ss/MPRss; option EN23; $C_L=50\text{pF}$
		-3	-	11	ns	MPss; option EN01; $C_L=50\text{pF}$
		-7	-	2	ns	MP+ss/MPRss; option EN01; $C_L=0\text{pF}$
		-5	-	3	ns	MP+sm/MPRsm; option EN01D; $C_L=0\text{pF}$
		-4	-	5	ns	MP+ss/MPRss; option EN23; $C_L=0\text{pF}$
		-7	-	4	ns	MPss; option EN01; $C_L=0\text{pF}$
SDI bit time	$t_{46}$ CC	$8 * t_{\text{MSC}}$	-	-	ns	Upstream Timing
SDI rise time <sup>7)</sup>	$t_{48}$ SR	-	-	200	ns	Upstream Timing
SDI fall time <sup>7)</sup>	$t_{49}$ SR	-	-	200	ns	Upstream Timing

1) FCLP signal rise/fall times are the rise/fall times of the LVDSM pads, and the high/low times are  $\min 1 * T_A$ .

2)  $T_A$  depends on the clock source selected for baud rate generation in the ABRA block of the MSC.

3) The capacitive load on the LVDS pins is differential, the capacitive load on the CMOS pins is single ended.

---

**Electrical Specification MSC Timing 5 V Operation**

- 4) The PLL jitter is not included. It should be considered additionally, corresponding to the used baudrate. The duty cycle can be adjusted if the ABRA block is used.
- 5) Positive deviation lengthens the high time and shortens the low time of a clock period. Negative deviation does the opposite.
- 6) From FCLP rising edge.
- 7) When using slow and asymmetrical edges, like in case of open drain upstream connection, the application must take care that the bit is long enough (the baud rate is low enough) so that under worst case conditions the three sampling points in the middle of the bit are not violated.

**Timing Options for  $t_{45}$**

The wiring shown in the **Figure 3-21** provides three useful timing options for  $t_{45}$ . depending on the signals selected with the alternate output lines (ALT1 to ALT7) in the ports:

- EN01 - FCLN, SON, EN0, EN1 -  $t_{45}$  reference timing
- EN01D - FCLND, SOND, EN0, EN1 -  $t_{45}$  window shifted to the left
- EN23 - FCLN, SON, EN2, EN3 -  $t_{45}$  window shifted to the right

The timings corresponding to EN01, EN01D, and EN23 are defined in the LVDS. In order to use the EN23 timings, the application should use the EN2 and EN3 outputs of the MSC module.

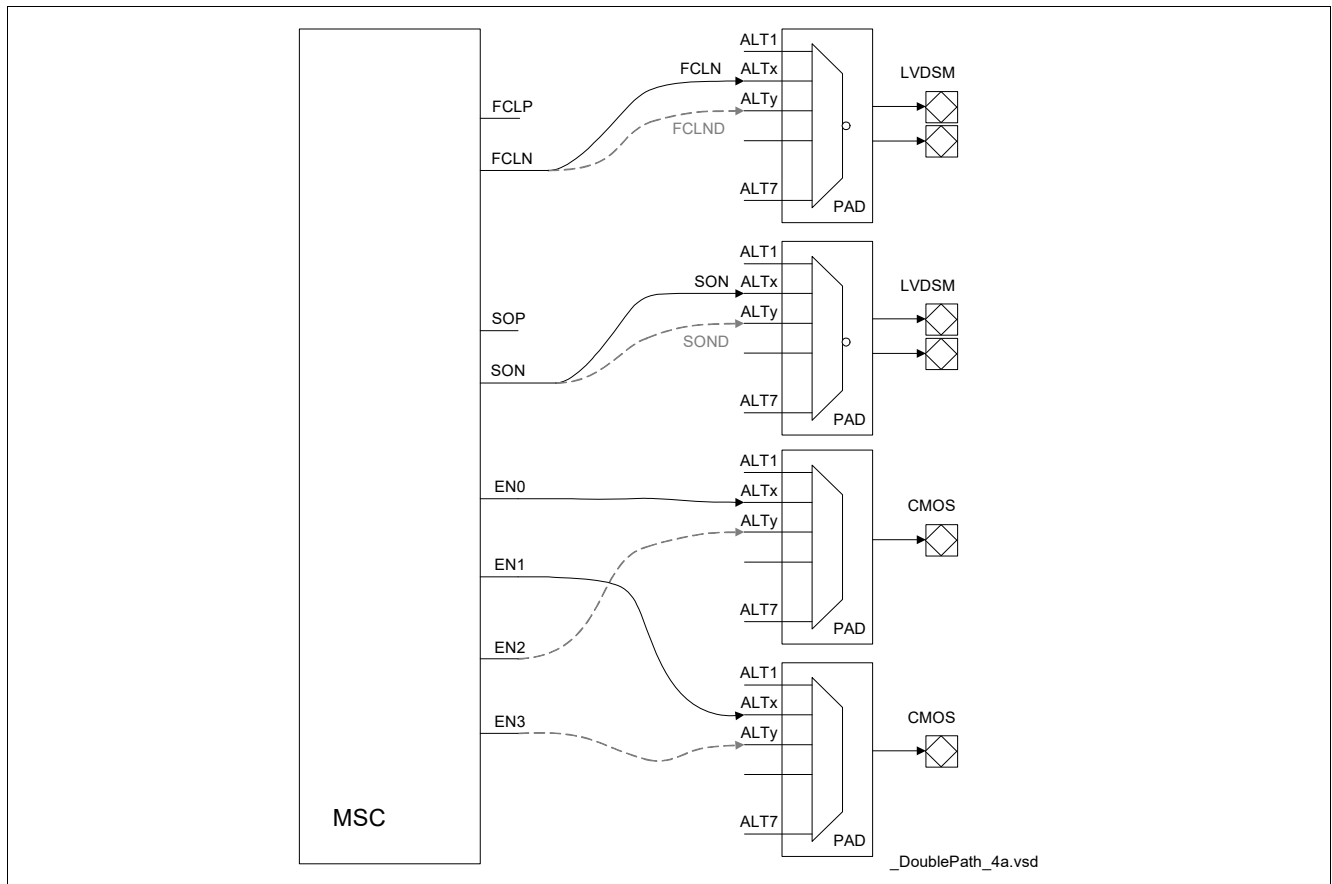

**Figure 3-21 Timing Options for  $t_{45}$**

**Table 3-75 MPss clock/data (LVDS pads in CMOS mode, option EN01)**

Parameter	Symbol	Values			Unit	Note / Test Condition
		Min.	Typ.	Max.		
FCLPx clock period <sup>1)</sup>	$t_{40}$ CC	$2 * T_A$ <sup>2) 3)</sup>	-	-	ns	MPss; $C_L=50pF$
Deviation from ideal duty cycle <sup>4) 5)</sup>	$t_{400}$ CC	-2	-	$6+0.035 * C_L$	ns	MPss; $0 < C_L < 100pF$
SOPx output delay <sup>6)</sup>	$t_{44}$ CC	-4	-	7	ns	MPss; $C_L=50pF$

**Electrical Specification MSC Timing 5 V Operation**
**Table 3-75 MPss clock/data (LVDS pads in CMOS mode, option EN01) (cont'd)**

Parameter	Symbol	Values			Unit	Note / Test Condition
		Min.	Typ.	Max.		
ENx output delay <sup>6)</sup>	$t_{45}$ CC	-5	-	7	ns	MP+ss/MPRss; $C_L=50\text{pF}$
		-2	-	15	ns	MP+sm/MPRsm; $C_L=50\text{pF}$
		-4	-	10	ns	MPss; $C_L=50\text{pF}$
		0	-	30	ns	MPsm; $C_L=50\text{pF}$ ; except pin P13.0
		0	-	31	ns	MPsm; $C_L=50\text{pF}$ ; pin P13.0
		6	-	45	ns	MPm/MP+m/MPRm; $C_L=50\text{pF}$
		-11	-	2	ns	MP+ss/MPRss; $C_L=0\text{pF}$
		-4	-	7	ns	MP+sm/MPRsm; $C_L=0\text{pF}$
		-10	-	2	ns	MPss; $C_L=0\text{pF}$
		-1	-	16	ns	MPsm; $C_L=0\text{pF}$
		-2	-	18	ns	MP+m/MPm/MPRm; $C_L=0\text{pF}$
SDI bit time	$t_{46}$ CC	$8 * t_{MSC}$	-	-	ns	Upstream Timing
SDI rise time <sup>7)</sup>	$t_{48}$ SR	-	-	200	ns	Upstream Timing
SDI fall time <sup>7)</sup>	$t_{49}$ SR	-	-	200	ns	Upstream Timing

- 1) FCLP signal rise/fall times are the rise/fall times of the LVDSM pads, and the high/low times are  $\min 1 * T_A$ .
- 2)  $T_A$  depends on the clock source selected for baud rate generation in the ABRA block of the MSC.
- 3) FCLP signal high and low can be minimum  $1 * T_{MSC}$ .
- 4) The PLL jitter is not included. It should be considered additionally, corresponding to the used baudrate. The duty cycle can be adjusted if the ABRA block is used.
- 5) Positive deviation lengthens the high time and shortens the low time of a clock period. Negative deviation does the opposite.
- 6) From FCLP rising edge.
- 7) When using slow and asymmetrical edges, like in case of open drain upstream connection, the application must take care that the bit is long enough (the baud rate is low enough) so that under worst case conditions the three sampling points in the middle of the bit are not violated.

**Table 3-76 MP+sm/MPRsm clock/data**

Parameter	Symbol	Values			Unit	Note / Test Condition
		Min.	Typ.	Max.		
FCLPx clock period <sup>1)</sup>	$t_{40}$ CC	$2 * T_A$	-	-	ns	MP+sm/MPRsm; $C_L=50\text{pF}$
Deviation from ideal duty cycle <sup>2) 3)</sup>	$t_{400}$ CC	-2	-	$3+0.01 * C_L$	ns	MP+sm/MPRsm; $0 < C_L < 200\text{pF}$
SOPx output delay <sup>4)</sup>	$t_{44}$ CC	-5	-	7	ns	MP+sm; $C_L=50\text{pF}$

**Electrical Specification MSC Timing 5 V Operation**
**Table 3-76 MP+sm/MPRsm clock/data (cont'd)**

Parameter	Symbol	Values			Unit	Note / Test Condition
		Min.	Typ.	Max.		
ENx output delay <sup>4)</sup>	$t_{45}$ CC	-13	-	2 <sup>5)</sup>	ns	MPss; $C_L=50\text{pF}$
		-5	-	11	ns	MP+sm/MPRsm; $C_L=50\text{pF}$
		1	-	24	ns	MPsm; $C_L=50\text{pF}$
		4	-	37	ns	MP+m/MPm/MPRm; $C_L=50\text{pF}$
		-19	-	-1	ns	MPss; $C_L=0\text{pF}$
		-13	-	2	ns	MP+sm; $C_L=0\text{pF}$
		-5	-	8	ns	MPsm; $C_L=0\text{pF}$
		-5	-	10	ns	MPm/MP+m/MPRm; $C_L=0\text{pF}$

- 1) FCLP signal rise/fall times are the rise/fall times of the LVDSM pads, and the high/low times are  $\min 1 * T_A$ .
- 2) The PLL jitter is not included. It should be considered additionally, corresponding to the used baudrate. The duty cycle can be adjusted if the ABRA block is used.
- 3) Positive deviation lengthens the high time and shortens the low time of a clock period. Negative deviation does the opposite.
- 4) From FCLP rising edge.
- 5) If EN1 is configured to P13.0 the max limit is increased by 0.5ns to 2.5ns.

**Table 3-77 MPm/MP+m/MPRm clock/data**

Parameter	Symbol	Values			Unit	Note / Test Condition
		Min.	Typ.	Max.		
FCLPx clock period <sup>1)</sup>	$t_{40}$ CC	$2 * T_A$	-	-	ns	MPm/MP+m/MPRm; $C_L=50\text{pF}$
Deviation from ideal duty cycle <sup>2) 3)</sup>	$t_{400}$ CC	-8	-	$15+0.04 * C_L$	ns	MPm/MP+m; $0 < C_L < 200\text{pF}$
SOPx output delay <sup>4)</sup>	$t_{44}$ CC	-11	-	9	ns	MPm/MP+m; $C_L=50\text{pF}$
ENx output delay <sup>4)</sup>	$t_{45}$ CC	-15	-	11	ns	MPm/MP+m/MPRm; $C_L=50\text{pF}$
		-33	-	-4	ns	MPm/MP+m/MPRm; $C_L=0\text{pF}$

- 1) FCLP signal rise/fall times are the rise/fall times of the LVDSM pads, and the high/low times are  $\min 1 * T_A$ .
- 2) The PLL jitter is not included. It should be considered additionally, corresponding to the used baudrate. The duty cycle can be adjusted if the ABRA block is used.
- 3) Positive deviation lengthens the high time and shortens the low time of a clock period. Negative deviation does the opposite.
- 4) From FCLP rising edge.

Electrical Specification MSC Timing 3.3 V Operation

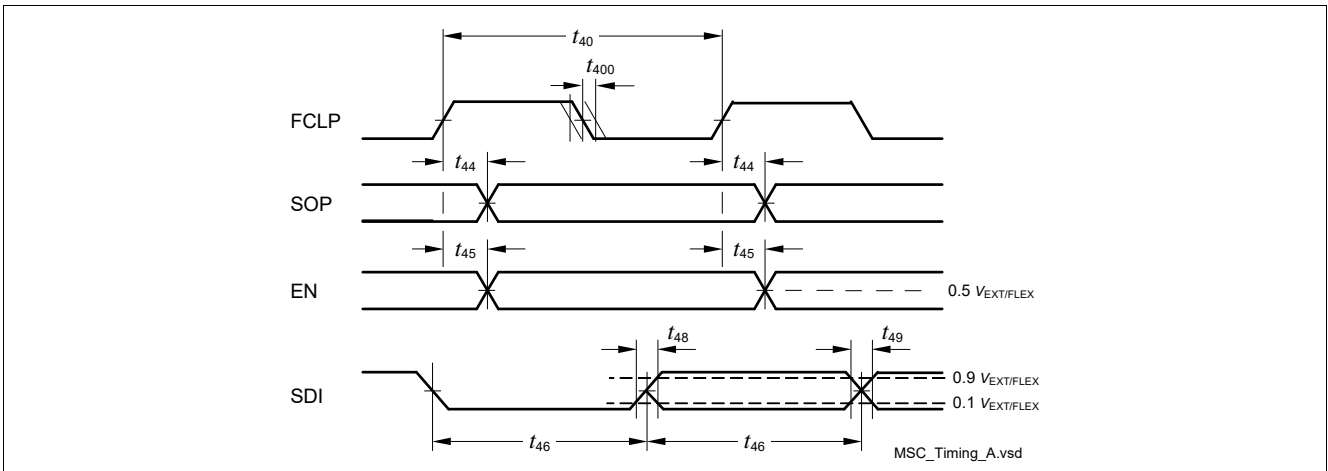

Figure 3-22 MSC Interface Timing

Note: The SOP data signal is sampled with the falling edge of FCLP in the target device.

### 3.28 MSC Timing 3.3 V Operation

The following section defines the timings for 3.3V pad power supply.

Note: Pad asymmetry is already included in the following timings.

Note: Load for LVDS pads are defined as differential loads in the following timings.

#### Mapping A, Combo Pads in LVDS Mode or CMOS Mode

The timing applies for the LVDS pads in LVDS operating mode:

- The LVDSM output pads for clock and data signals set in LVDS mode
- The CMOS MP pads for enable signals, with strong driver sharp edge (MPss) or strong driver medium edge (MPsm).

Table 3-78 LVDS clock/data (LVDS pads in LVDS mode)

Parameter	Symbol	Values			Unit	Note / Test Condition
		Min.	Typ.	Max.		
FCLPx clock period <sup>1)</sup>	$t_{40}$ CC	$2 * T_A$ <sup>2) 3)</sup>	-	-	ns	LVDSM; $C_L=50pF$
Deviation from ideal duty cycle <sup>4) 5)</sup>	$t_{400}$ CC	-2	-	2	ns	LVDSM; $0 < C_L < 50pF$
SOPx output delay <sup>6)</sup>	$t_{44}$ CC	-5	-	5	ns	LVDSM; $C_L=50pF$ ; option EN01
		-7	-	7	ns	LVDSM; $C_L=50pF$ ; option EN01D

**Electrical Specification MSC Timing 3.3 V Operation**
**Table 3-78 LVDS clock/data (LVDS pads in LVDS mode) (cont'd)**

Parameter	Symbol	Values			Unit	Note / Test Condition
		Min.	Typ.	Max.		
ENx output delay <sup>6)</sup>	$t_{45}$ CC	-7	-	10	ns	MP+ss/MPRss; option EN01; $C_L=25\text{pF}$
		-5	-	13	ns	MP+ss/MPRss; option EN01; $C_L=50\text{pF}$
		-5	-	26	ns	MP+sm/MPRsm; option EN01D; $C_L=50\text{pF}$
		-4	-	16	ns	MP+ss/MPRss; option EN23; $C_L=25\text{pF}$
		-4	-	17	ns	MP+ss/MPRss; option EN23; $C_L=50\text{pF}$
		-5	-	19	ns	MPss; option EN01; $C_L=50\text{pF}$
		-12	-	4	ns	MP+ss/MPRss; option EN01; $C_L=0\text{pF}$
		-9	-	11	ns	MP+sm/MPRsm; option EN01D; $C_L=0\text{pF}$
		-7	-	9	ns	MP+ss/MPRss; option EN23; $C_L=0\text{pF}$
		-12	-	7	ns	MPss; option EN01; $C_L=0\text{pF}$
SDI bit time	$t_{46}$ CC	$8 * t_{MSC}$	-	-	ns	Upstream Timing
SDI rise time <sup>7)</sup>	$t_{48}$ SR	-	-	200	ns	Upstream Timing
SDI fall time <sup>7)</sup>	$t_{49}$ SR	-	-	200	ns	Upstream Timing

- 1) FCLP signal rise/fall times are the rise/fall times of the LVDSM pads, and the high/low times are  $\min 1 * T_A$ .
- 2)  $T_{Amin} = T_{MAX}$ . When  $T_{MAX} = 100 \text{ MHz}$ ,  $t_{40} = 20 \text{ ns}$
- 3) The capacitive load on the LVDS pins is differential, the capacitive load on the CMOS pins is single ended.
- 4) The PLL jitter is not included. It should be considered additionally, corresponding to the used baudrate. The duty cycle can be adjusted if the ABRA block is used.
- 5) Positive deviation lengthens the high time and shortens the low time of a clock period. Negative deviation does the opposite.
- 6) From FCLP rising edge.
- 7) When using slow and asymmetrical edges, like in case of open drain upstream connection, the application must take care that the bit is long enough (the baud rate is low enough) so that under worst case conditions the three sampling points in the middle of the bit are not violated.

**Table 3-79 MPss clock/data (LVDS pads in CMOS mode, option EN01)**

Parameter	Symbol	Values			Unit	Note / Test Condition
		Min.	Typ.	Max.		
FCLPx clock period <sup>1)</sup>	$t_{40}$ CC	$2 * T_A$ <sup>2) 3)</sup>	-	-	ns	MPss; $C_L=50\text{pF}$
Deviation from ideal duty cycle <sup>4) 5)</sup>	$t_{400}$ CC	-5	-	$7+0.07 * C_L$	ns	MPss; $0 < C_L < 100\text{pF}$

**Electrical Specification MSC Timing 3.3 V Operation**
**Table 3-79 MPss clock/data (LVDS pads in CMOS mode, option EN01) (cont'd)**

Parameter	Symbol	Values			Unit	Note / Test Condition
		Min.	Typ.	Max.		
SOPx output delay <sup>6)</sup>	$t_{44}$ CC	-7	-	12	ns	MPss; $C_L=50\text{pF}$
ENx output delay <sup>6)</sup>	$t_{45}$ CC	-9	-	12	ns	MP+ss/MPRss; $C_L=50\text{pF}$
		-4	-	26	ns	MP+sm/MPRsm; $C_L=50\text{pF}$
		-7	-	17	ns	MPss; $C_L=50\text{pF}$
		0	-	54	ns	MPsm; $C_L=50\text{pF}$ ; except pin P13.0
		0	-	58	ns	MPsm; $C_L=50\text{pF}$ ; pin P13.0
		4	-	77	ns	MPm/MP+m/MPRm; $C_L=50\text{pF}$
		-19	-	4	ns	MP+ss/MPRss; $C_L=0\text{pF}$
		-7	-	12	ns	MP+sm/MPRsm; $C_L=0\text{pF}$
		-17	-	4	ns	MPss; $C_L=0\text{pF}$
		-2	-	28	ns	MPsm; $C_L=0\text{pF}$
-4	-	31	ns	MP+m/MPm/MPRm; $C_L=0\text{pF}$		
SDI bit time	$t_{46}$ CC	$8 * t_{MSC}$	-	-	ns	Upstream Timing
SDI rise time <sup>7)</sup>	$t_{48}$ SR	-	-	200	ns	Upstream Timing
SDI fall time <sup>7)</sup>	$t_{49}$ SR	-	-	200	ns	Upstream Timing

1) FCLP signal rise/fall times are the rise/fall times of the LVDSM pads, and the high/low times are  $\min 1 * T_A$ .

2)  $T_{Amin} = T_{MAX}$ . When  $T_{MAX} = 100 \text{ MHz}$ ,  $t_{40} = 20 \text{ ns}$

3) FCLP signal high and low can be minimum  $1 * T_{MSC}$ .

4) The PLL jitter is not included. It should be considered additionally, corresponding to the used baudrate. The duty cycle can be adjusted if the ABRA block is used.

5) Positive deviation lengthens the high time and shortens the low time of a clock period. Negative deviation does the opposite.

6) From FCLP rising edge.

7) When using slow and asymmetrical edges, like in case of open drain upstream connection, the application must take care that the bit is long enough (the baud rate is low enough) so that under worst case conditions the three sampling points in the middle of the bit are not violated.

### Mapping B, CMOS MP Pads

This timing applies for the dedicated CMOS pads, pin Mapping B:

- MP strong sharp (MPss) output pads for the clock and the data signals
- MP strong sharp or strong medium (MPss or MPsm) output pads for enable signals

**Electrical Specification MSC Timing 3.3 V Operation**
**Table 3-80 MP+sm/MPRsm clock/data**

Parameter	Symbol	Values			Unit	Note / Test Condition
		Min.	Typ.	Max.		
FCLPx clock period <sup>1)</sup>	$t_{40}$ CC	$2 * T_A$	-	-	ns	MP+sm/MPRsm; $C_L=50\text{pF}$
Deviation from ideal duty cycle <sup>2) 3)</sup>	$t_{400}$ CC	-3	-	7	ns	MP+sm/MPRsm; $0 < C_L < 200\text{pF}$
SOPx output delay <sup>4)</sup>	$t_{44}$ CC	-9	-	12	ns	MP+sm; $C_L=50\text{pF}$
ENx output delay <sup>4)</sup>	$t_{45}$ CC	-20	-	4	ns	MPss; $C_L=50\text{pF}$
		-9	-	19	ns	MP+sm/MPRsm; $C_L=50\text{pF}$
		0	-	44	ns	MPsm; $C_L=50\text{pF}$
		0	-	63	ns	MP+m/MPm/MPRm; $C_L=50\text{pF}$
		-33	-	0	ns	MPss; $C_L=0\text{pF}$
		-23	-	4	ns	MP+sm/MPRsm; $C_L=0\text{pF}$
		-9	-	14	ns	MPsm; $C_L=0\text{pF}$
		-9	-	17	ns	MPm/MP+m/MPRm; $C_L=0\text{pF}$

- 1) FCLP signal rise/fall times are the rise/fall times of the LVDSM pads, and the high/low times are  $\min 1 * T_A$ .
- 2) The PLL jitter is not included. It should be considered additionally, corresponding to the used baudrate. The duty cycle can be adjusted if the ABRA block is used.
- 3) Positive deviation lengthens the high time and shortens the low time of a clock period. Negative deviation does the opposite.
- 4) From FCLP rising edge.

**Table 3-81 MPm/MP+m/MPRm clock/data**

Parameter	Symbol	Values			Unit	Note / Test Condition
		Min.	Typ.	Max.		
FCLPx clock period <sup>1)</sup>	$t_{40}$ CC	$2 * T_A$	-	-	ns	MPm/MP+m/MPRm; $C_L=50\text{pF}$
Deviation from ideal duty cycle <sup>2) 3)</sup>	$t_{400}$ CC	$-6-0.07 * C_L$	-	$6+0.07 * C_L$	ns	MPm/MP+m/MPRm; $0 < C_L < 200\text{pF}$
SOPx output delay <sup>4)</sup>	$t_{44}$ CC	-19	-	17	ns	MPm/MP+m; $C_L=50\text{pF}$
ENx output delay <sup>4)</sup>	$t_{45}$ CC	-19	-	20	ns	MPm/MP+m/MPRm; $C_L=50\text{pF}$
		-57	-	0	ns	MPm/MP+m/MPRm; $C_L=0\text{pF}$

- 1) FCLP signal rise/fall times are the rise/fall times of the LVDSM pads, and the high/low times are  $\min 1 * T_A$ .
- 2) The PLL jitter is not included. It should be considered additionally, corresponding to the used baudrate. The duty cycle can be adjusted if the ABRA block is used.
- 3) Positive deviation lengthens the high time and shortens the low time of a clock period. Negative deviation does the opposite.



### 3.29 Ethernet Interface (ETH) Characteristics

#### 3.29.1 ETH Measurement Reference Points

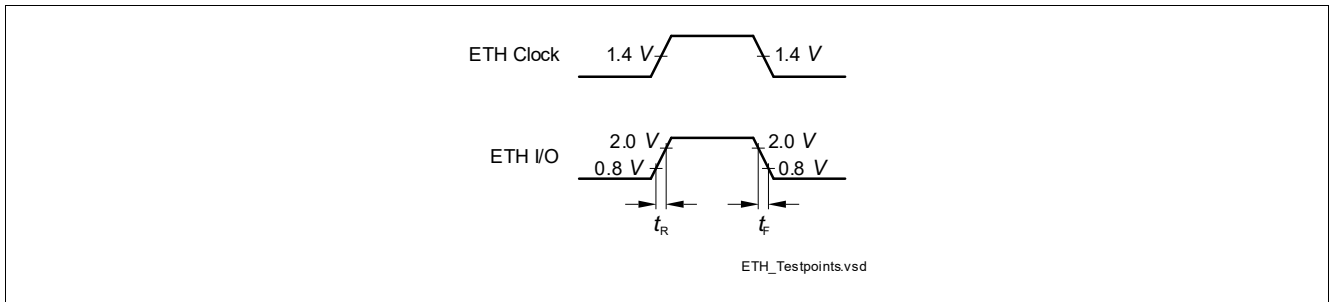

Figure 3-24 ETH Measurement Reference Points

### 3.29.2 ETH Management Signal Parameters (ETH\_MDC, ETH\_MDIO)

Table 3-82 ETH Management Signal Parameters

Parameter	Symbol	Values			Unit	Note / Test Condition
		Min.	Typ.	Max.		
ETH_MDC period	$t_1$ CC	400	-	-	ns	$C_L=25pF$
ETH_MDC high time	$t_2$ CC	160	-	-	ns	$C_L=25pF$
ETH_MDC low time	$t_3$ CC	160	-	-	ns	$C_L=25pF$
ETH_MDIO setup time (output)	$t_4$ CC	10	-	-	ns	$C_L=25pF$
ETH_MDIO hold time (output)	$t_5$ CC	10	-	-	ns	$C_L=25pF$
ETH_MDIO data valid (input)	$t_6$ SR	0	-	300	ns	$C_L=25pF$

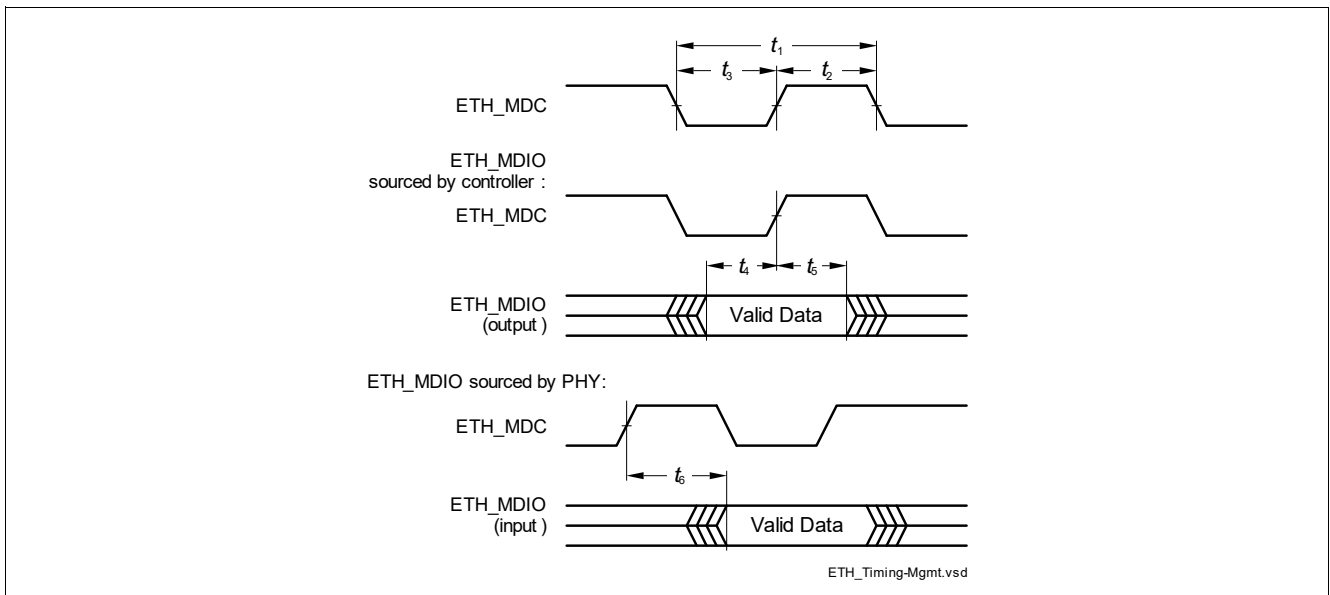

Figure 3-25 ETH Management Signal Timing

Electrical Specification Ethernet Interface (ETH) Characteristics

3.29.3 ETH MII Parameters

In the following, the parameters of the MII (Media Independent Interface) are described.

Table 3-83 ETH MII Signal Timing Parameters

Parameter	Symbol	Values			Unit	Note / Test Condition
		Min.	Typ.	Max.		
Clock period	$t_7$ SR	40	-	-	ns	$C_L=25pF$ ; baudrate=100Mbps
		400	-	-	ns	$C_L=25pF$ ; baudrate=10Mbps
Clock high time	$t_8$ SR	14	-	26	ns	$C_L=25pF$ ; baudrate=100Mbps
		140 <sup>1)</sup>	-	260 <sup>2)</sup>	ns	$C_L=25pF$ ; baudrate=10Mbps
Clock low time	$t_9$ SR	14	-	26	ns	$C_L=25pF$ ; baudrate=100Mbps
		140 <sup>1)</sup>	-	260 <sup>2)</sup>	ns	$C_L=25pF$ ; baudrate=10Mbps
Input setup time	$t_{10}$ SR	10	-	-	ns	$C_L=25pF$
Input hold time	$t_{11}$ SR	10	-	-	ns	$C_L=25pF$
Output valid time	$t_{12}$ CC	0	-	25	ns	$C_L=25pF$

- 1) Defined by 35% of clock period.
- 2) Defined by 65% of clock period.

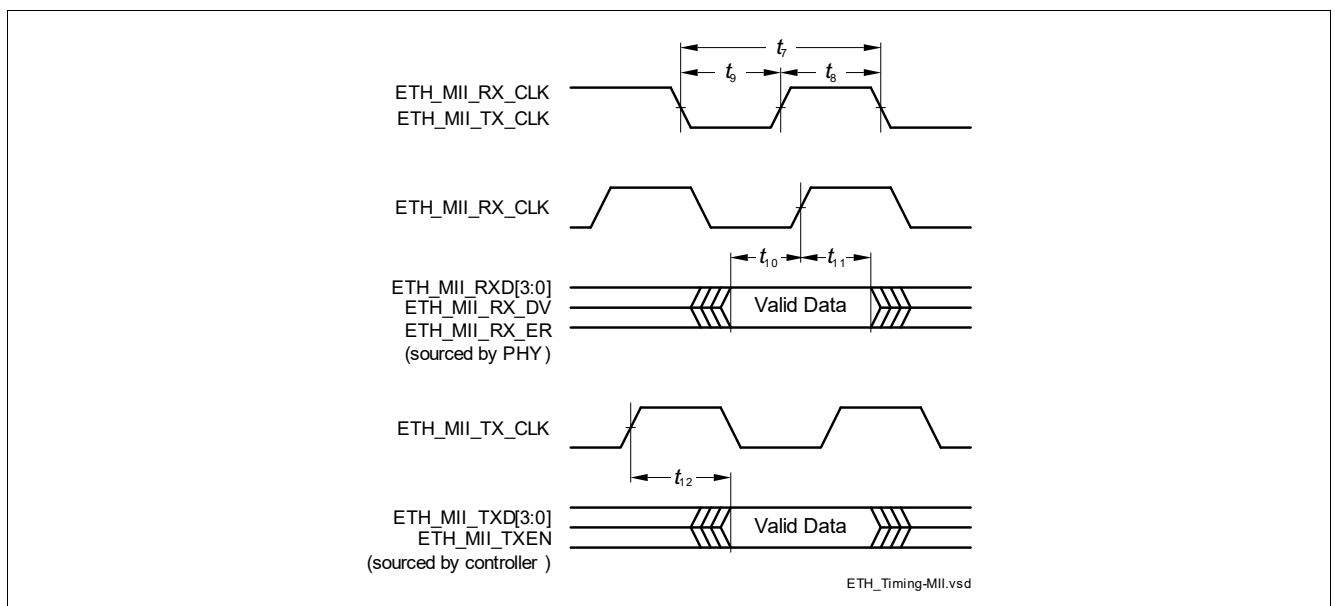

Figure 3-26 ETH MII Signal Timing

### 3.29.4 ETH RMII Parameters

In the following, the parameters of the RMII (Reduced Media Independent Interface) are described.

Table 3-84 ETH RMII Signal Timing Parameters

Parameter	Symbol	Values			Unit	Note / Test Condition
		Min.	Typ.	Max.		
ETH_RMII_REF_CL clock period	$t_{13}$ CC	20	-	-	ns	$C_L=25\text{pF}$ ; 50ppm
ETH_RMII_REF_CL clock high time	$t_{14}$ CC	7 <sup>1)</sup>	-	13 <sup>2)</sup>	ns	$C_L=25\text{pF}$
ETH_RMII_REF_CL clock low time	$t_{15}$ CC	7 <sup>1)</sup>	-	13 <sup>2)</sup>	ns	$C_L=25\text{pF}$
ETHTXEN, ETHTXD[1:0], ETHRXD[1:0], ETHCRSDV, ETHRXER; setup time	$t_{16}$ CC	4	-	-	ns	$C_L=25\text{pF}$
ETHTXEN, ETHTXD[1:0], ETHRXD[1:0], ETHCRSDV, ETHRXER; hold time	$t_{17}$ CC	2	-	-	ns	$C_L=25\text{pF}$

1) Defined by 35% of clock period.

2) Defined by 65% of clock period.

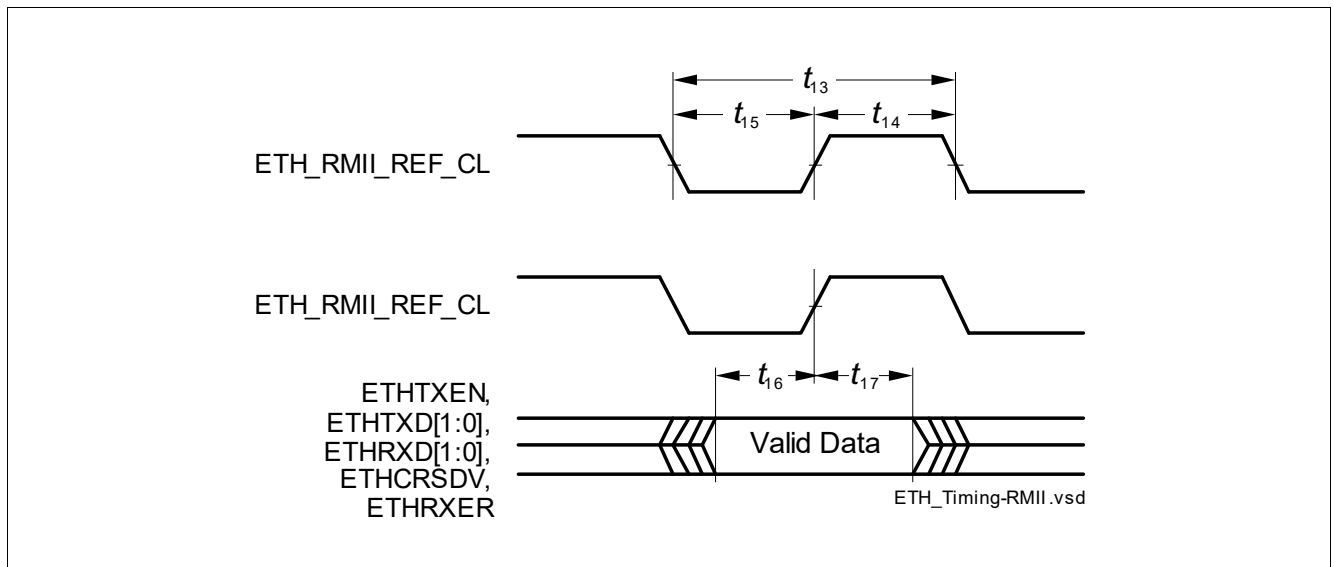

Figure 3-27 ETH RMII Signal Timing

### 3.30 E-Ray Parameters

The timings of this section are valid for the strong driver and either sharp edge settings of the output drivers with  $C_L = 25 \text{ pF}$ . For the inputs the hysteresis has to be configured to inactive.

**Table 3-85 Transmit Parameters**

Parameter	Symbol	Values			Unit	Note / Test Condition
		Min.	Typ.	Max.		
Rise time of TxEN	$t_{dCCTxENRise25CC}$	-	-	9	ns	$C_L=25\text{pF}$
Fall time of TxEN	$t_{dCCTxENFall25CC}$	-	-	9	ns	$C_L=25\text{pF}$
Sum of rise and fall time	$t_{dCCTxRise25+dCCTxFall25CC}$	-	-	9	ns	20% - 80%; $C_L=25\text{pF}$
Sum of delay between TP1_FF and TP1_CC and delays derived from TP1_FFi, rising edge of TxEN	$t_{dCCTxEN01CC}$	-	-	25	ns	
Sum of delay between TP1_FF and TP1_CC and delays derived from TP1_FFi, falling edge of TxEN	$t_{dCCTxEN10CC}$	-	-	25	ns	
Asymmetry of sending	$t_{tx\_asym} CC$	-2.45	-	2.45	ns	$C_L=25\text{pF}$
Sum of delay between TP1_FF and TP1_CC and delays derived from TP1_FFi, rising edge of TxD	$t_{dCCTxD01CC}$	-	-	25	ns	
Sum of delay between TP1_FF and TP1_CC and delays derived from TP1_FFi, falling edge of TxD	$t_{dCCTxD10CC}$	-	-	25	ns	
TxD signal sum of rise and fall time at TP1_BD	$t_{txd\_sum} CC$	-	-	9	ns	

**Table 3-86 Receive Parameters**

Parameter	Symbol	Values			Unit	Note / Test Condition
		Min.	Typ.	Max.		
Acceptance of asymmetry at receiving part	$t_{dCCTxAsymAccept25SR}$	-30.5	-	43.0	ns	$C_L=25\text{pF}$
Acceptance of asymmetry at receiving part	$t_{dCCTxAsymAccept15SR}$	-31.5	-	44.0	ns	$C_L=15\text{pF}$
Threshold for detecting logical high	$T_{uCCLogic1} SR$	35	-	70	%	
Threshold for detecting logical low	$T_{uCCLogic0} SR$	30	-	65	%	

**Table 3-86 Receive Parameters** (cont'd)

Parameter	Symbol	Values			Unit	Note / Test Condition
		Min.	Typ.	Max.		
Sum of delay between TP4_CC and TP4_FF and delays derived from TP4_FFi, rising edge of RxD	$t_{dCCRxD01}$ CC	-	-	10	ns	
Sum of delay between TP1_CC and TP1_CC and delays derived from TP4_FFi, falling edge of RxD	$t_{dCCRxD10}$ CC	-	-	10	ns	

### 3.31 HSCT Parameters

**Table 3-87 HSCT - Rx/Tx setup timing**

Parameter	Symbol	Values			Unit	Note / Test Condition
		Min.	Typ.	Max.		
RX o/p duty cycle	$DC_{rx}$ CC	40	-	60	%	
Bias startup time	$t_{bias}$ CC	-	5	10	$\mu$ s	Bias distributor waking up from power down and provide stable Bias.
RX startup time	$t_{rx}$ CC	-	5	-	$\mu$ s	Wake-up RX from power down.
TX startup time	$t_{tx}$ CC	-	5	-	$\mu$ s	Wake-up TX from power down.

**Table 3-88 HSCT - Rx parasitics and loads**

Parameter	Symbol	Values			Unit	Note / Test Condition
		Min.	Typ.	Max.		
Capacitance total budget	$C_{total}$ CC	-	3.5	5	pF	Total Budget for complete receiver including silicon, package, pins and bond wire
Parasitic inductance budget	$H_{total}$ CC	-	5	-	nH	

**Table 3-89 LVDSH - Reduced TX and RX (RED)**

Parameter	Symbol	Values			Unit	Note / Test Condition
		Min.	Typ.	Max.		
Output differential voltage	$V_{OD}$ CC	150	200	285	mV	$R_t = 100 \text{ Ohm } \pm 20\%$ @2pF
Output voltage high	$V_{OH}$ CC	-	-	1463	mV	$R_t = 100 \text{ Ohm } \pm 20\%$
Output voltage low	$V_{OL}$ CC	937	-	-	mV	$R_t = 100 \text{ Ohm } \pm 20\%$
Output offset (Common mode) voltage	$V_{OS}$ CC	1.08	1.2	1.32	V	$R_t = 100 \text{ Ohm } \pm 20\%$ @2pF
Input voltage range	$V_I$ SR	-	-	1.6	V	Absolute max = $1.6 \text{ V} + (285\text{mV}/2) = 1.743$
		0.15	-	-	V	Absolute min = $0.15 \text{ V} - (285 \text{ mV} / 2) = 0 \text{ V}$
Input differential threshold	$V_{idth}$ SR	-100	-	100	mV	100 mV for 55% of bit period; Note Absolute Value ( $V_{idth} - V_{idthl}$ )
Data frequency	$DR$ CC	5	-	320	Mbps	

**Electrical Specification HSCT Parameters**
**Table 3-89 LVDSH - Reduced TX and RX (RED) (cont'd)**

Parameter	Symbol	Values			Unit	Note / Test Condition
		Min.	Typ.	Max.		
Receiver differential input impedance	$R_{in}$ CC	90	100	110	Ohm	$0\text{ V} < V_I < 1.6\text{V}$
		80	100	120	Ohm	$1.6\text{ V} < V_I < 2.0\text{V}$
Slew rate	$SR_{tx}$ CC	-	-	2	V/ns	
Change in VOS between 0 and 1	$dVOS$ CC	-	-	50	mV	Peak to peak (including DC transients).
Change in Vod between 0 and 1	$dVod$ CC	-	-	50	mV	Peak to peak (including DC transients)
Fall time <sup>1)</sup>	$t_{fall}$ CC	0.26	-	1.2	ns	$R_t = 100\text{ Ohm} \pm 20\%$ @2pF
Rise time <sup>1)</sup>	$t_{rise}$ CC	0.26	-	1.2	ns	$R_t = 100\text{ Ohm} \pm 20\%$ @2pF

1) Rise / fall times are defined for 10% - 90% of  $V_{OD}$

**Table 3-90 HSCT PLL**

Parameter	Symbol	Values			Unit	Note / Test Condition
		Min.	Typ.	Max.		
PLL frequency range	$f_{PLL}$ CC	12.5	320	320	MHz	
PLL input frequency	$f_{REF}$ CC	10	-	20	MHz	
PLL lock-in time	$t_{LOCK}$ CC	-	-	50	$\mu\text{s}$	
Bit Error Rate based on 10 MHz reference clock at Slave PLL side	$BER_{10}$ CC	-	-	10EXP-9	-	Bit Error Rate based on Slave interface reference clock at 10 MHz
Bit Error Rate based on 20 MHz reference clock at Slave PLL side	$BER_{20}$ CC	-	-	10EXP-12	-	Bit Error Rate based on Slave interface reference clock at 20 MHz
Absolute RMS Jitter (TX out)	$J_{ABS10}$ CC	-125	-	125	ps	Measured at link TX out; valid for Reference frequency at 10 MHz
Absolute RMS Jitter (TX out)	$J_{ABS20}$ CC	-85	-	85	ps	Measured at link TX out; valid for Reference frequency at 20 MHz

**Electrical Specification HSCT Parameters**
**Table 3-90 HSCT PLL (cont'd)**

Parameter	Symbol	Values			Unit	Note / Test Condition
		Min.	Typ.	Max.		
Accumulated RMS Jitter (RX side)	$J_{ACC10}$ CC	-	-	145	ps	Measured at link RX input, based on 5000 measures, each 300 clock cycles; valid for Reference frequency at 10 MHz
Accumulated RMS Jitter (link RX side)	$J_{ACC20}$ CC	-	-	115	ps	Measured at link RX input, based on 5000 measures, each 300 clock cycles; valid for Reference frequency at 20 MHz
Total Jitter peak to peak	$TJ_{pp}$ CC	-	-	2083	ps	Total Jitter as sum of deterministic jitter and random jitter

**Table 3-91 HSCT Sysclk**

Parameter	Symbol	Values			Unit	Note / Test Condition
		Min.	Typ.	Max.		
Frequency	$f_{SYSCLK}$ CC	10	-	20	MHz	
Frequency error	$dfERR$ CC	-1	-	1	%	
Duty Cycle	$DC_{sys}$ CC	45	-	55	%	
Load impedance	$R_{LOAD}$ CC	10	-	-	kOhm	
Load capacitance	$C_{LOAD}$ CC	-	-	10	pF	
Integrated phase noise	$I_{PN}$ CC	-	-	-58	dB	single sideband phase noise in 10 kHz to 10 Mhz at 20 MHz SysClk

### 3.32 Inter-IC (I2C) Interface Timing

This section defines the timings for I2C in the TC270 / TC275 / TC277.

All I2C timing parameter are SR for Master Mode and CC for Slave Mode.

**Table 3-92 I2C Standard Mode Timing**

Parameter	Symbol	Values			Unit	Note / Test Condition
		Min.	Typ.	Max.		
Fall time of both SDA and SCL	$t_1$	-	-	300	ns	Measured with a pull-up resistor of 4.7 kohms at each of the SCL and SDA line
Capacitive load for each bus line	$C_b$ SR	-	-	400	pF	
Bus free time between a STOP and ATART condition	$t_{10}$	4.7	-	-	$\mu$ s	Measured with a pull-up resistor of 4.7 kohms at each of the SCL and SDA line
Rise time of both SDA and SCL	$t_2$	-	-	1000	ns	Measured with a pull-up resistor of 4.7 kohms at each of the SCL and SDA line
Data hold time	$t_3$	0	-	-	$\mu$ s	Measured with a pull-up resistor of 4.7 kohms at each of the SCL and SDA line
Data set-up time	$t_4$	250	-	-	ns	Measured with a pull-up resistor of 4.7 kohms at each of the SCL and SDA line
Low period of SCL clock	$t_5$	4.7	-	-	$\mu$ s	Measured with a pull-up resistor of 4.7 kohms at each of the SCL and SDA line
High period of SCL clock	$t_6$	4	-	-	$\mu$ s	Measured with a pull-up resistor of 4.7 kohms at each of the SCL and SDA line
Hold time for the (repeated) START condition	$t_7$	4	-	-	$\mu$ s	Measured with a pull-up resistor of 4.7 kohms at each of the SCL and SDA line

**Electrical Specification Inter-IC (I2C) Interface Timing**
**Table 3-92 I2C Standard Mode Timing (cont'd)**

Parameter	Symbol	Values			Unit	Note / Test Condition
		Min.	Typ.	Max.		
Set-up time for (repeated) START condition	$t_8$	4.7	-	-	$\mu\text{s}$	Measured with a pull-up resistor of 4.7 kohms at each of the SCL and SDA line
Set-up time for STOP condition	$t_9$	4	-	-	$\mu\text{s}$	Measured with a pull-up resistor of 4.7 kohms at each of the SCL and SDA line

**Table 3-93 I2C Fast Mode Timing**

Parameter	Symbol	Values			Unit	Note / Test Condition
		Min.	Typ.	Max.		
Fall time of both SDA and SCL	$t_1$	$20+0.1 \cdot C_b$	-	300	ns	Measured with a pull-up resistor of 4.7 kohms at each of the SCL and SDA line
Capacitive load for each bus line	$C_b$ SR	-	-	400	pF	
Bus free time between a STOP and ATART condition	$t_{10}$	1.3	-	-	$\mu\text{s}$	Measured with a pull-up resistor of 4.7 kohms at each of the SCL and SDA line
Rise time of both SDA and SCL	$t_2$	$20+0.1 \cdot C_b$	-	300	ns	Measured with a pull-up resistor of 4.7 kohms at each of the SCL and SDA line
Data hold time	$t_3$	0	-	-	$\mu\text{s}$	Measured with a pull-up resistor of 4.7 kohms at each of the SCL and SDA line
Data set-up time	$t_4$	100	-	-	ns	Measured with a pull-up resistor of 4.7 kohms at each of the SCL and SDA line
Low period of SCL clock	$t_5$	1.3	-	-	$\mu\text{s}$	Measured with a pull-up resistor of 4.7 kohms at each of the SCL and SDA line
High period of SCL clock	$t_6$	0.6	-	-	$\mu\text{s}$	Measured with a pull-up resistor of 4.7 kohms at each of the SCL and SDA line

## Electrical Specification Inter-IC (I2C) Interface Timing

Table 3-93 I2C Fast Mode Timing (cont'd)

Parameter	Symbol	Values			Unit	Note / Test Condition
		Min.	Typ.	Max.		
Hold time for the (repeated) START condition	$t_7$	0.6	-	-	$\mu\text{s}$	Measured with a pull-up resistor of 4.7 kohms at each of the SCL and SDA line
Set-up time for (repeated) START condition	$t_8$	0.6	-	-	$\mu\text{s}$	Measured with a pull-up resistor of 4.7 kohms at each of the SCL and SDA line
Set-up time for STOP condition	$t_9$	0.6	-	-	$\mu\text{s}$	Measured with a pull-up resistor of 4.7 kohms at each of the SCL and SDA line

### 3.33 Flash Target Parameters

Program Flash program and erase operation is only allowed up the  $T_J = 150^\circ\text{C}$ .

**Table 3-94 FLASH**

Parameter	Symbol	Values			Unit	Note / Test Condition
		Min.	Typ.	Max.		
Program Flash Erase Time per logical sector	$t_{\text{ERP}} \text{ CC}$	-	-	1	s	cycle count < 1000
		-	$0.207 + 0.003 * (S \text{ [KByte]} / (f_{\text{FSI}} \text{ [MHz]})^1)$	-	s	cycle count < 1000, for sector of size S
Program Flash Erase Time per Multi-Sector Command	$t_{\text{MERP}} \text{ CC}$	-	-	1	s	For consecutive logical sectors in a physical sector, cycle count < 1000
		-	$0.207 + 0.003 * (S \text{ [KByte]} / (f_{\text{FSI}} \text{ [MHz]})^1)$	-	s	For consecutive logical sector range of size S in a physical sector, cycle count < 1000
Program Flash program time per page in 5 V mode	$t_{\text{PRP5}} \text{ CC}$	-	-	$50 + 3000 / (f_{\text{FSI}} \text{ [MHz]})$	$\mu\text{s}$	32 Byte
Program Flash program time per page in 3.3 V mode	$t_{\text{PRP3}} \text{ CC}$	-	-	$81 + 3400 / (f_{\text{FSI}} \text{ [MHz]})$	$\mu\text{s}$	32 Byte
Program Flash program time per burst in 5 V mode	$t_{\text{PRPB5}} \text{ CC}$	-	-	$125 + 9500 / (f_{\text{FSI}} \text{ [MHz]})$	$\mu\text{s}$	256 Byte
Program Flash program time per burst in 3.3 V mode	$t_{\text{PRPB3}} \text{ CC}$	-	-	$410 + 12000 / (f_{\text{FSI}} \text{ [MHz]})$	$\mu\text{s}$	256 Byte
Program Flash program time for 1 MByte with burst programming in 3 V mode excluding communication	$t_{\text{PRPB3\_1MB}} \text{ CC}$	-	-	2.2	s	Derived value for documentation purpose, valid for $f_{\text{FSI}} = 100\text{MHz}$
Program Flash program time for 1 MByte with burst programming in 5 V mode excluding communication	$t_{\text{PRPB5\_1MB}} \text{ CC}$	-	-	0.9	s	Derived value for documentation purpose, valid for $f_{\text{FSI}} = 100\text{MHz}$
Program Flash program time for complete PFlash with burst programming in 5 V mode excluding communication	$t_{\text{PRPB5\_PF}} \text{ CC}$	-	-	3.6	s	Derived value for documentation purpose, valid for $f_{\text{FSI}} = 100\text{MHz}$

**Electrical Specification Flash Target Parameters**
**Table 3-94 FLASH (cont'd)**

Parameter	Symbol	Values			Unit	Note / Test Condition
		Min.	Typ.	Max.		
Write Page Once adder	$t_{ADD}$ CC	-	-	$15 + 500/(f_{FSI} \text{ [MHz]})$	$\mu\text{s}$	Adder to Program Time when using Write Page Once
Program Flash suspend to read latency	$t_{SPNDP}$ CC	-	-	$12000/(f_{FSI} \text{ [MHz]})$	$\mu\text{s}$	For Write Burst, Verify Erased and for multi-(logical) sector erase commands
Data Flash Erase Time per Sector <sup>2)</sup>	$t_{ERD}$ CC	-	$0.12 + 0.08/(f_{FSI} \text{ [MHz]})^1$	-	s	cycle count < 1000
		-	$0.57 + 0.15/(f_{FSI} \text{ [MHz]})^1$	$0.928 + 0.15/(f_{FSI} \text{ [MHz]})$	s	cycle count < 125000
Data Flash Erase Time per Multi-Sector Command <sup>2)</sup>	$t_{MERD}$ CC	-	$0.12 + 0.01 * (S \text{ [KByte]}) / (f_{FSI} \text{ [MHz]})^1$	-	s	For consecutive logical sector range of size S, cycle count < 1000
		-	$0.57 + 0.019 * (S \text{ [KByte]}) / (f_{FSI} \text{ [MHz]})^1$	$0.928 + 0.019 * (S \text{ [KByte]}) / (f_{FSI} \text{ [MHz]})$	s	For consecutive logical sector range of size S, cycle count < 125000
Data Flash erase disturb limit	$N_{DFD}$ CC	-	-	50	cycles	
Program time data flash per page <sup>3)</sup>	$t_{PRD}$ CC	-	-	$50 + 2500/(f_{FSI} \text{ [MHz]})^3$	$\mu\text{s}$	8 Byte
Complete Device Flash Erase Time PFlash and DFlash <sup>4)</sup>	$t_{ER\_Dev}$ CC	-	-	9	s	Derived value for documentation purpose (excl. UCBs and HSMs), valid for $f_{FSI} = 100\text{MHz}$
Data Flash program time per burst <sup>3)</sup>	$t_{PRDB}$ CC	-	-	$96 + 4400/(f_{FSI} \text{ [MHz]})^3$	$\mu\text{s}$	32 Bytes
Data Flash suspend to read latency	$t_{SPNDD}$ CC	-	-	$12000/(f_{FSI} \text{ [MHz]})$	$\mu\text{s}$	
Wait time after margin change	$t_{FL\_MarginDel}$ CC	-	-	10	$\mu\text{s}$	
Program Flash Retention Time, Sector	$t_{RET}$ CC	20	-	-	years	Max. 1000 erase/program cycles
Data Flash Endurance per EEPROMx sector <sup>5)</sup>	$N_{E\_EEP10}$ CC	125000	-	-	cycles	Max. data retention time 10 years

**Electrical Specification Flash Target Parameters**
**Table 3-94 FLASH (cont'd)**

Parameter	Symbol	Values			Unit	Note / Test Condition
		Min.	Typ.	Max.		
Data Flash Endurance per HSMx sector <sup>5)</sup>	$N_{E\_HSM}$ CC	125000	-	-	cycles	Max. data retention time 10 years
UCB Retention Time	$t_{RTU}$ CC	20	-	-	years	Max. 100 erase/program cycles per UCB, max 400 erase/program cycles in total
Data Flash access delay	$t_{DF}$ CC	-	-	100	ns	see PMU_FCON.WSDFLASH
Data Flash ECC Delay	$t_{DFECC}$ CC	-	-	20	ns	see PMU_FCON.WSECDF
Program Flash access delay	$t_{PF}$ CC	-	-	30	ns	see PMU_FCON.WSPFLASH
Program Flash ECC delay	$t_{PFECC}$ CC	-	-	10	ns	see PMU_FCON.WSECPF
Number of erase operations on DF0 over lifetime	$N_{ERD0}$ CC	-	-	750000	cycles	
Number of erase operations on DF1 over lifetime	$N_{ERD1}$ CC	-	-	500000	cycles	
Junction temperature limit for PFlash program/erase operations	$T_{JPFlash}$ SR	-	-	150	°C	

- 1) All typical values were characterised, but are not tested. Typical values are safe median values at room temperature
- 2) Under out-of-spec conditions (e.g. over-cycling) or in case of activation of WL oriented defects, the duration of erase processes may be increased by up to 50%.
- 3) Time is not dependent on program mode (5V or 3.3V).
- 4) Using 512 KByte erase commands.
- 5) Only valid when a robust EEPROM emulation algorithm is used. For more details see the Users Manual.

3.34 Package Outline

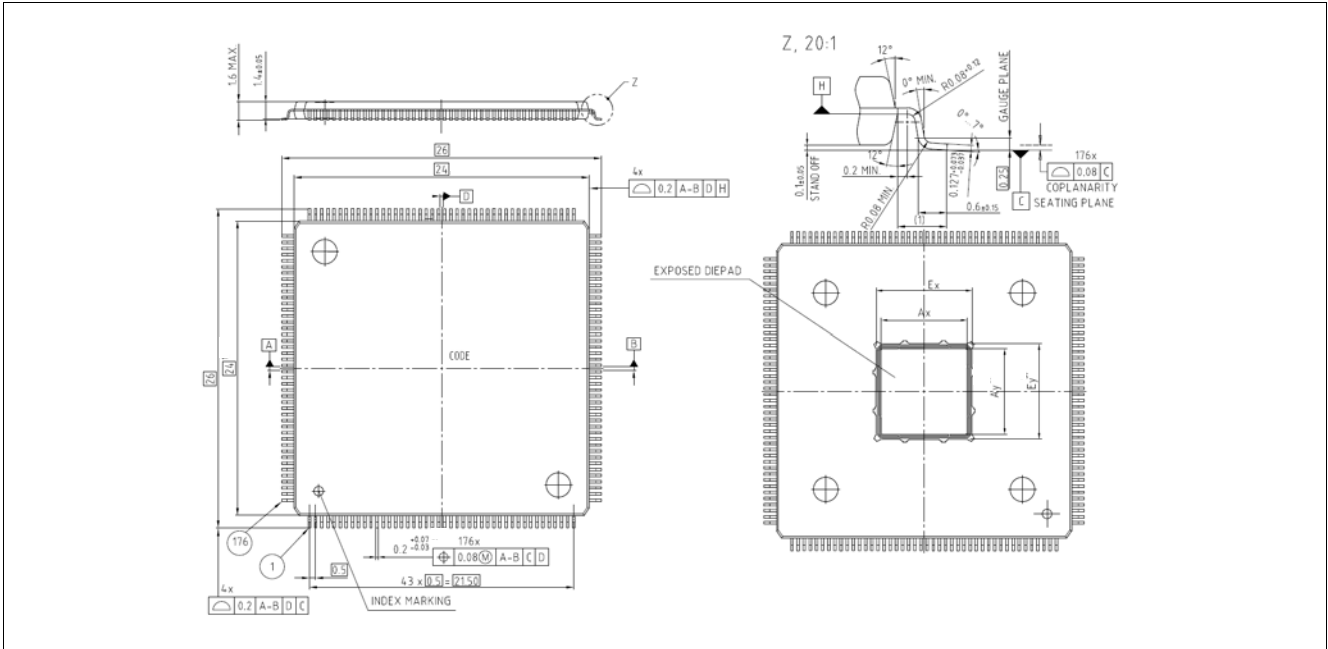

Figure 3-28 Package Outlines PG-LQFP-176-22

Table 3-95 Exposed Pad Dimensions

<b>Ax (nominal EPad size)</b>	<b>7.9 mm ± 50 µm</b>
<b>Ay (nominal EPad size)</b>	<b>7.9 mm ± 50 µm</b>
<b>Ex (solder able EPad size)</b>	<b>8.7 mm ± 50 µm</b>
<b>Ey (solder able EPad size)</b>	<b>8.7 mm ± 50 µm</b>

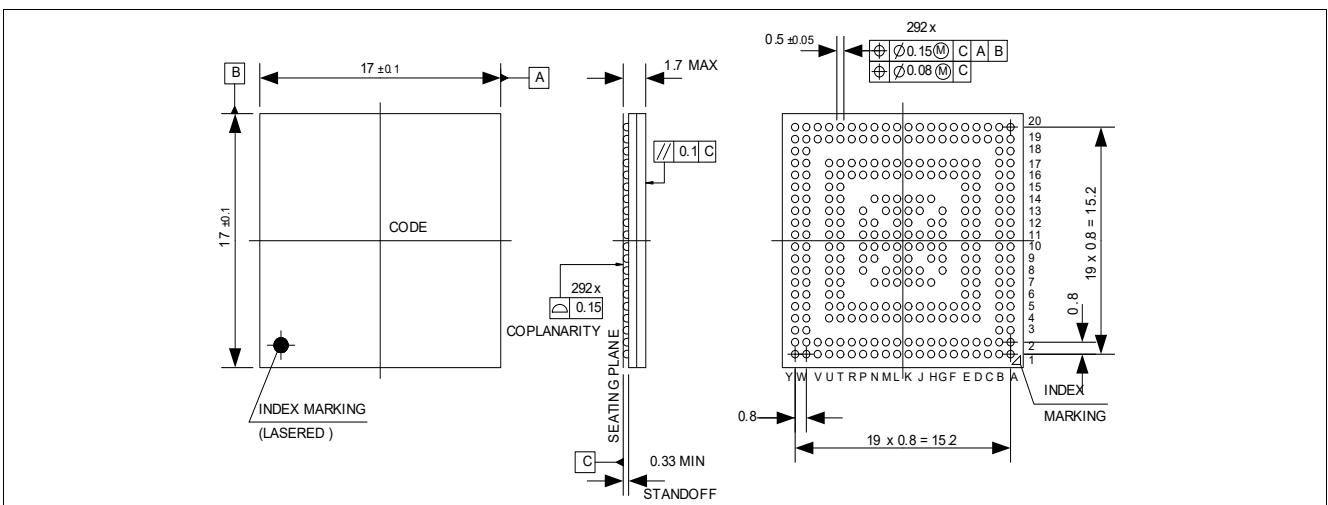

Figure 3-29 Package Outlines LF-BGA-292-6 / LF-BGA-292-10

You can find all of our packages, sorts of packing and others in our Infineon Internet Page “Products”: <http://www.infineon.com/products>.

### 3.34.1 Package Parameters

Table 3-96 Thermal Characteristics of the Package

Device	Package	RQJCT <sup>1)</sup>	RQJCB <sup>1)</sup>	RQJA	Unit	Note
TC275	PG-LQFP-176-22	9,6	1,25	14,7 <sup>2)</sup>	K/W	with soldered exposed pad
TC277	LF-BGA-292-6 / LF-BGA-292-10	5,1	7,2	15,8 <sup>3)</sup>	K/W	

- 1) The top and bottom thermal resistances between the case and the ambient ( $R_{TCAT}$ ,  $R_{TCAB}$ ) are to be combined with the thermal resistances between the junction and the case given above ( $R_{TJCT}$ ,  $R_{TJCB}$ ), in order to calculate the total thermal resistance between the junction and the ambient ( $R_{TJA}$ ). The thermal resistances between the case and the ambient ( $R_{TCAT}$ ,  $R_{TCAB}$ ) depend on the external system (PCB, case) characteristics, and are under user responsibility. The junction temperature can be calculated using the following equation:  $T_J = T_A + R_{TJA} * P_D$ , where the  $R_{TJA}$  is the total thermal resistance between the junction and the ambient. This total junction ambient resistance  $R_{TJA}$  can be obtained from the upper four partial thermal resistances.  
Thermal resistances as measured by the 'cold plate method' (MIL SPEC-883 Method 1012.1).
- 2) Value is defined in accordance with JEDEC JESD51-3, JESD51-5, and JESD51-7.
- 3) Value is defined in accordance with JEDEC JESD51-1.

### 3.34.2 TC270 Carrier Tape

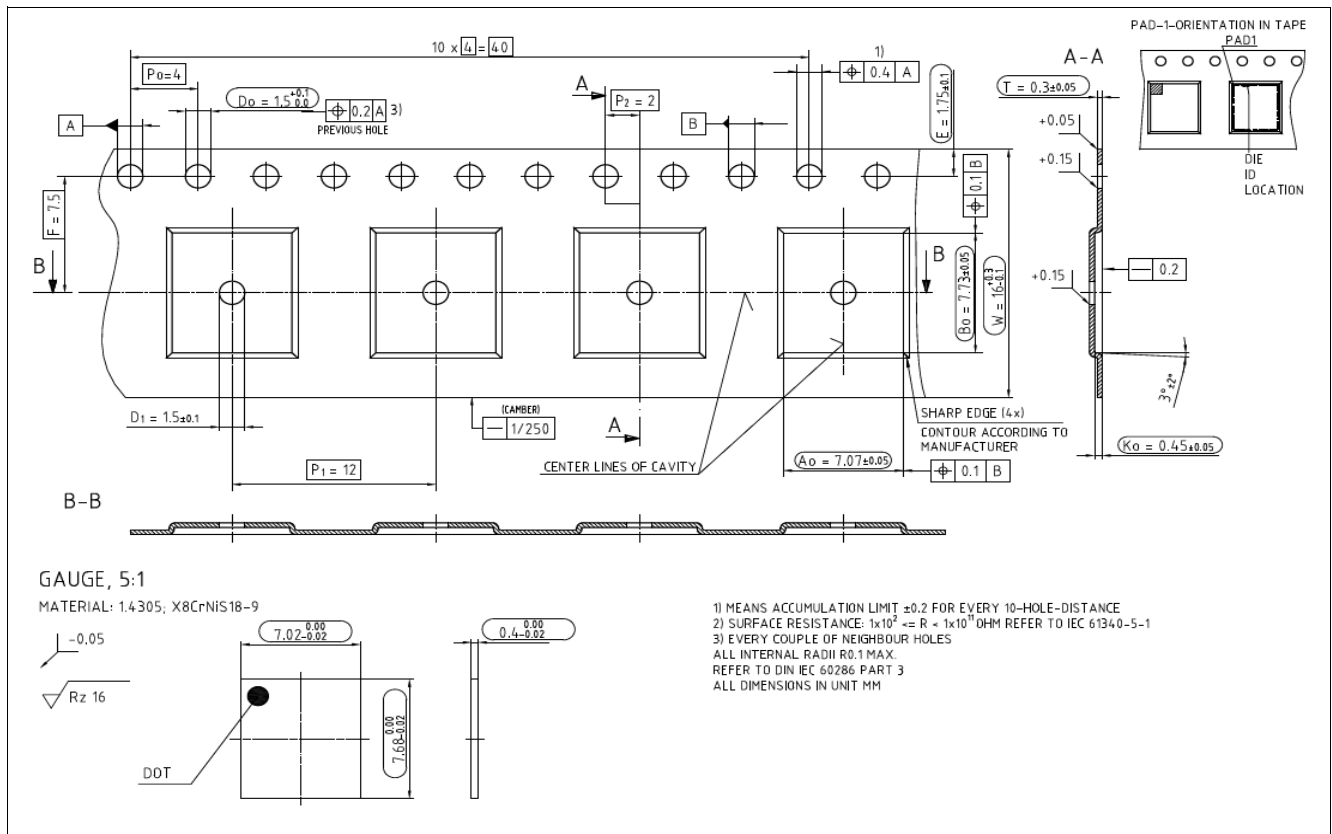

Figure 3-30 Carrier Tape Dimensions

Table 3-97 TC270 Chip Dimensions

Device	A	B	T
TC270	7,590 mm	6,930 mm	0,3 mm

### 3.35 Quality Declarations

**Table 3-98 Quality Parameters**

Parameter	Symbol	Values			Unit	Note / Test Condition
		Min.	Typ.	Max.		
Operation Lifetime	$t_{OP}$	-	-	24500	hour	
ESD susceptibility according to Human Body Model (HBM)	$V_{HBM}$	-	-	2000	V	Conforming to JESD22-A114-B
ESD susceptibility of the LVDS pins	$V_{HBM1}$	-	-	500	V	
ESD susceptibility according to Charged Device Model (CDM)	$V_{CDM}$	-	-	500	V	for all other balls/pins; conforming to JESD22-C101-C
		-	-	750	V	for corner balls/pins; conforming to JESD22-C101-C
Moisture Sensitivity Level	$MSL$	-	-	3		Conforming to Jedec J-STD--020C for 240C

## 4 History

Version 0.6 is the first version of this document.

### 4.1 Changes from version version 0.6 to 0.7

- Changes in table 'Overload Parameters' of Overload
  - Add max  $1.7 \cdot 10^{-3}$  to  $K_{OV\text{DN}}$
  - Add max  $2 \cdot 10^{-2}$  to  $K_{OV\text{DN}}$
  - Add max  $1 \cdot 10^{-2}$  to  $K_{OV\text{DN}}$
  - Add max  $1 \cdot 10^{-4}$  to  $K_{OV\text{DP}}$
  - Add max  $1 \cdot 10^{-2}$  to  $K_{OV\text{AN}}$
  - Change note of  $K_{OV\text{AN}}$  from ' $-5\text{mA} < I_{\text{IN}} < -1\text{mA}$ ' to 'Analog Inputs overlaid with class LP pads or pull down diagnostics;  $-5\text{mA} < I_{\text{IN}} < -1\text{mA}$ '
  - Change max value of  $K_{OV\text{AN}}$  from  $3 \cdot 10^{-3}$  to  $1 \cdot 10^{-2}$
  - Change min value of  $I_{\text{INANA}}$  from -1 mA to -3 mA
  - Change note of  $K_{OV\text{AN}}$  from 'else' to 'else;  $-5\text{mA} < I_{\text{IN}} < 0\text{mA}$ '
  - Change note of  $K_{OV\text{AP}}$  from 'else' to ' $5\text{mA} < I_{\text{IN}} < 0\text{mA}$ '
  - Change max value of  $K_{OV\text{AN}}$  from  $1 \cdot 10^{-3}$  to  $6 \cdot 10^{-4}$
  - Change note of  $K_{OV\text{AN}}$  from 'Analog Inputs overlaid with class LP pads or pull down diagnostics' to 'Analog Inputs overlaid with class LP pads or pull down diagnostics;  $-1\text{mA} < I_{\text{IN}} < 0\text{mA}$ '
  - Change note of  $K_{OV\text{DP}}$  from 'Overload injected on LVDS pad and affecting neighbor LVDS pad' to 'Overload injected on LVDS pad and affecting neighbor LVDS pads'
  - Change note of  $K_{OV\text{DP}}$  from 'Overload injected on GPIO non LVDS pad and affecting neighbor GPIO non LVDS pad' to 'Overload injected on GPIO non LVDS pad and affecting neighbor GPIO non LVDS pads'
  - Change max value of  $K_{OV\text{DN}}$  from 0.9 to 0.93
  - Change note of  $K_{OV\text{DN}}$  from 'Overload injected on GPIO non LVDS pad and affecting neighbor GPIO non LVDS pad' to 'Overload injected on GPIO non LVDS pad and affecting neighbor LP and A2 pads;  $-2\text{mA} < I_{\text{IN}} < 0\text{mA}$ '
  - Change max value of  $K_{OV\text{DN}}$  from  $1.5 \cdot 10^{-3}$  to  $6 \cdot 10^{-4}$
  - Change note of  $K_{OV\text{DN}}$  from 'Overload injected on LVDS pad and affecting neighbor LVDS pad' to 'Overload injected on LVDS pad and affecting neighbor LVDS pads'
- VADC
  - Add min 0 pC to  $Q_{\text{CONV}}$
  - Add min 8 pC to  $Q_{\text{CONV}}$
  - Add max 10 pC to  $Q_{\text{CONV}}$
  - Add max 2  $\mu\text{A}$  to  $I_{\text{OZ2}}$
  - Change min value of  $I_{\text{OZ3}}$  from -2.5  $\mu\text{A}$  to -3.3  $\mu\text{A}$
  - Change note of  $I_{\text{OZ3}}$  from '-1  $\mu\text{A}$ ' to '-2  $\mu\text{A}$ '
  - Change max value of  $I_{\text{OZ2}}$  from 2  $\mu\text{A}$  to 3  $\mu\text{A}$
  - Add min -2.8  $\mu\text{A}$  to  $I_{\text{OZ3}}$
  - Add max 2.5  $\mu\text{A}$  to  $I_{\text{OZ3}}$
  - Add max 20 pC to  $Q_{\text{CONV}}$
  - Add min -2  $\mu\text{A}$  to  $I_{\text{OZ2}}$

## HistoryChanges from version version 0.6 to 0.7

- Add min  $V_{SSM}$  V to  $V_{AGND}$
- Add max 7  $\mu$ A to  $I_{OZ2}$
- Add min -13  $\mu$ A to  $I_{OZ3}$
- Add min -4  $\mu$ A to  $I_{OZ2}$
- Add max 4  $\mu$ A to  $I_{OZ2}$
- Add min -7  $\mu$ A to  $I_{OZ3}$
- Add max 7  $\mu$ A to  $I_{OZ3}$
- Add max 13  $\mu$ A to  $I_{OZ3}$
- Add typ 0.5 LSB to  $EN_{RMS}$
- Add min -7  $\mu$ A to  $I_{OZ2}$
- Change note of  $Q_{CONV}$  from ' $V_{AIN} = 5V$ , charge consumed from reference pin, precharging disabled' to ' $V_{AIN} = 5 V$ , charge consumed from reference pin, precharging disabled'
- Change typ value of  $Q_{CONV}$  from 80 pC to 14 pC
- Change predicate of  $t_{BVG}$  from typ to max
- Change max value of  $t_{BVG}$  from 50 cycles to 120 cycles
- Change predicate of  $t_{BWR}$  from typ to max
- Change max value of  $t_{BWR}$  from 50 cycles to 60 cycles
- Change note of  $I_{OZ1}$  from 'Analog Inputs overlaid with GPIO functions or pull down diagnosis or DSADC inputs' to 'Analog Inputs overlaid with class LP pads or pull down diagnostics'
- Change note of  $Q_{CONV}$  from ' $V_{AIN} = 5V$ , charge consumed from reference pin, precharging enabled' to ' $V_{AIN} = 5 V$ , charge consumed from reference pin, precharging enabled'
- Change typ value of  $Q_{CONV}$  from 20 pC to 3 pC
- Change note of  $EN_{RMS}$  from 'target' to "
- Change max value of  $EN_{RMS}$  from 0.5 LSB to 0.75 LSB
- Change note of  $R_{AIN}$  from 'valid for analoge inputs mapped to GPIOs' to 'valid for analog inputs mapped to GPIOs'
- VADC\_33V
  - Add min 0 pC to  $Q_{CONV}$
  - Add min 4 pC to  $Q_{CONV}$
  - Add max 15 pC to  $Q_{CONV}$
  - Add max 8 pC to  $Q_{CONV}$
  - Add min -2  $\mu$ A to  $I_{OZ2}$
  - Add max 2.5  $\mu$ A to  $I_{OZ2}$
  - Add min -2.2  $\mu$ A to  $I_{OZ3}$
  - Add max 2  $\mu$ A to  $I_{OZ3}$
  - Add max 12  $\mu$ A to  $I_{OZ3}$
  - Add min -6 LSB to  $EA_{GAIN}$
  - Add min -12 LSB to  $TUE$
  - Add max 12 LSB to  $TUE$
  - Add min -12 LSB to  $EA_{INL}$
  - Add max 12 LSB to  $EA_{INL}$
  - Add min -6 LSB to  $EA_{OFF}$

## HistoryChanges from version version 0.6 to 0.7

- Add max 6 LSB to  $EA_{OFF}$
- Add max 6 LSB to  $EA_{GAIN}$
- Add min -3.5  $\mu A$  to  $I_{OZ2}$
- Add min -6  $\mu A$  to  $I_{OZ2}$
- Add max 3.5  $\mu A$  to  $I_{OZ2}$
- Add max 6  $\mu A$  to  $I_{OZ2}$
- Add min -6.5  $\mu A$  to  $I_{OZ3}$
- Add min -12  $\mu A$  to  $I_{OZ3}$
- Add max 6.5  $\mu A$  to  $I_{OZ3}$
- Add max 150 °C to  $T_J$
- Add min  $V_{SSM}$  V to  $V_{AGND}$
- Add min 150 °C to  $T_J$
- Add max 10 % to  $dVCSD$
- Add max 28 kOhm to  $R_{CSD}$
- Change note of  $TUE$  from '12-bit resolution' to '12-bit Resolution;  $T_J \leq 150$  °C'
- Change note of  $EA_{DNL}$  from " to '12-bit resolution'
- Change note of  $EA_{INL}$  from " to '12-bit Resolution;  $T_J \leq 150$  °C'
- Change note of  $EA_{OFF}$  from " to '12-bit Resolution;  $T_J \leq 150$  °C'
- Change note of  $EA_{GAIN}$  from " to '12-bit Resolution;  $T_J \leq 150$  °C'
- Change note of  $I_{OZ1}$  from 'Analog Inputs overlaid with GPIO functions or pull down diagnosis or DSADC inputs' to 'Analog Inputs overlaid with class LP pads or pull down diagnostics'
- Change note of  $Q_{CONV}$  from ' $V_{AIN} = 3.3V$ , charge consumed from reference pin, precharging disabled' to ' $V_{AIN} = 3.3$  V, charge consumed from reference pin, precharging disabled'
- Change typ value of  $Q_{CONV}$  from 60 pC to 7 pC
- Change note of  $Q_{CONV}$  from ' $V_{AIN} = 3.3V$ , charge consumed from reference pin, precharging enabled' to ' $V_{AIN} = 3.3$  V, charge consumed from reference pin, precharging enabled'
- Change typ value of  $Q_{CONV}$  from 15 pC to 3 pC
- Change max value of  $t_{BWG}$  from 50 cycles to 120 cycles
- Change predicate of  $t_{BWG}$  from typ to max
- Change max value of  $t_{BWR}$  from 50 cycles to 60 cycles
- Change predicate of  $t_{BWR}$  from typ to max
- Change description of  $I_{OZ2}$  from 'Positive reference pin leakage' to 'Positive reference  $V_{AREFX}$  pin leakage'
- Change description of  $I_{OZ3}$  from 'Negative reference pin leakage' to 'Negative reference  $V_{AGNDx}$  pin leakage'
- Add footnote 'This parameter is valid for soldered devices and requires careful analog board design.' to  $ENRMS$
- Change max value of  $R_{AIN}$  from 1.5 kOhm to 1.6 kOhm
- EVR/LDO/1.3V
  - Add max 6.3  $\mu F$  to  $C_{OUT}$
  - Add min 3  $\mu F$  to  $C_{OUT}$
  - Change note of  $dVout/dIout$  from ' $dI=-150mA$ ;  $Tsettle=20\mu s$ ; pass device=off chip' to ' $dI=-150mA$ ;  $Tsettle=20\mu s$ ; pass device=off chip'
- EVR/Back-up Clock
  - Add footnote 'All  $V_{EXT}$  pins shall be connected together externally on the PCB.' to  $V_{EXT}$

- Changes in table 'EVR13 SMPS External components' of EVR/DCDC
  - Change name of  $C_{OUTDC}$  from CDC to COUTDC
- Changes in table 'EVR13 SMPS' of EVR/DCDC
  - Change note of  $dV_{out}/dI_{out}$  from ' $dI < 200mA ; f_{DCDC}=1MHz; t_r=0.1\mu s; t_f=0.1\mu s; V_{DDDC}=1.3V$ ' to ' $dI < 200mA ; f_{DCDC}=1MHz; t_r=0.1\mu s; t_f=0.1\mu s; V_{DDDC}=1.3V$ '
  - Change note of  $dV_{out}/dI_{out}$  from ' $dI < 700mA ; f_{DCDC}=1MHz; t_r=0.1\mu s; t_f=0.1\mu s; V_{DDDC}=1.3V$ ' to ' $dI < 700mA ; f_{DCDC}=1MHz; t_r=0.1\mu s; t_f=0.1\mu s; V_{DDDC}=1.3V$ '
  - Change note of  $dV_{out}/dI_{out}$  from ' $dI < 400mA ; f_{DCDC}=1MHz; t_r=0.1\mu s; t_f=0.1\mu s; V_{DDDC}=1.3V$ ' to ' $dI < 400mA ; f_{DCDC}=1MHz; t_r=0.1\mu s; t_f=0.1\mu s; V_{DDDC}=1.3V$ '
  - Add footnote 'Incase of SMPS mode, It shall be ensured that the VDD Output pin shall be connected on PCB level to all other  $V_{DD}$  Input pins.' to  $V_{DDDC}$
  - Add footnote 'Capacitor min-max range represent typical  $\pm 35\%$  tolerance including DC bias effect. The trace resistance from the capacitor to the supply or ground rail should be limited to 25 mOhm.' to  $C_{OUTDC}$
  - Add footnote 'Incase of TC29x running with  $f_{SRI} = 300$  MHz, it shall be ensured that the VDD operating range is limited to 1.235V upto 1.430V. The DCDC may be configured in this case with a nominal voltage of  $1.33V \pm 7.5\%$ . The static accuracy and regulation parameter ranges remain also valid for this case.' to  $V_{DD\_DC}$
- FLASH
  - Add max 2.2 s to  $t_{PRPB3\_1MB}$
  - Change note of  $t_{ERD}$  from " to 'cycle count < 125000'
  - Change max value of  $t_{ERD}$  from 1 s to  $0.928 + 0.15/(f_{FSI} [MHz])$  s
  - Change max value of  $t_{PRD}$  from 75  $\mu s$  to  $50 + 2500/(f_{FSI} [MHz])$   $\mu s$
  - Change note of  $t_{MERP}$  from 'For consecutive logical sectors in a physical sector' to 'For consecutive logical sectors in a physical sector, cycle count < 1000'
  - Change max value of  $t_{PRP5}$  from 80  $\mu s$  to  $50 + 3000/(f_{FSI} [MHz])$   $\mu s$
  - Change max value of  $t_{PRPB5}$  from 220  $\mu s$  to  $125 + 9500/(f_{FSI} [MHz])$   $\mu s$
  - Change max value of  $t_{PRPB3}$  from 530  $\mu s$  to  $410 + 12000/(f_{FSI} [MHz])$   $\mu s$
  - Change note of  $t_{PRPB5\_1MB}$  from 'Derived value for documentation purpose' to 'Derived value for documentation purpose, valid for  $f_{FSI} = 100MHz$ '
  - Change note of  $t_{PRPB5\_PF}$  from 'Derived value for documentation purpose' to 'Derived value for documentation purpose, valid for  $f_{FSI} = 100MHz$ '
  - Change max value of  $t_{ADD}$  from 20  $\mu s$  to  $15 + 500/(f_{FSI} [MHz])$   $\mu s$
  - Change max value of  $t_{SPNDP}$  from 120  $\mu s$  to  $12000/(f_{FSI} [MHz])$   $\mu s$
  - Change note of  $t_{MERC}$  from 'For consecutive logical sectors' to 'For consecutive logical sector range of size S, cycle count < 125000'
  - Change max value of  $t_{MERC}$  from 1 s to  $0.928 + 0.019 * (S [KByte]) / (f_{FSI} [MHz])$  s
  - Change note of  $t_{ER\_Dev}$  from 'Derived value for documentation purpose (excl. UCBs and HSMs)' to 'Derived value for documentation purpose (excl. UCBs and HSMs); valid for  $f_{FSI} = 100MHz$ '
  - Change max value of  $t_{PRDB}$  from 140  $\mu s$  to  $96 + 4400/(f_{FSI} [MHz])$   $\mu s$
  - Change max value of  $t_{SPNDD}$  from 120  $\mu s$  to  $12000/(f_{FSI} [MHz])$   $\mu s$
  - Change max value of  $t_{PRP3}$  from 115  $\mu s$  to  $81 + 3400/(f_{FSI} [MHz])$   $\mu s$
  - Add typ  $0.12 + 0.08/(f_{FSI} [MHz])$  s to  $t_{ERD}$
  - Add typ  $0.207 + 0.003 * (S [KByte]) / (f_{FSI} [MHz])$  s to  $t_{MERP}$
  - Add typ  $0.12 + 0.01 * (S [KByte]) / (f_{FSI} [MHz])$  s to  $t_{MERC}$

**HistoryChanges from version version 0.6 to 0.7**

- Add typ  $0.207 + 0.003 * (S \text{ [KByte]}) / (f_{FSI} \text{ [MHz]})$  s to  $t_{ERP}$
- Add typ  $0.57 + 0.15/(f_{FSI} \text{ [MHz]})$  s to  $t_{ERD}$
- Add typ  $0.57 + 0.019 * (S \text{ [KByte]}) / (f_{FSI} \text{ [MHz]})$  s to  $t_{MERD}$
- DSADC
  - Change note of  $SNR$  from ' $f_{PB} = 30\text{kHz}$ ' to ' $f_{PB} = 30 \text{ kHz}; V_{DDM} = \pm 5\%$ '
  - Change min value of  $SNR$  from 76 dB to 80 dB
  - Change note of  $SNR$  from ' $f_{PB} = 50\text{kHz}$ ' to ' $f_{PB} = 50 \text{ kHz}; V_{DDM} = \pm 5\%$ '
  - Change min value of  $SNR$  from 74 dB to 78 dB
  - Add footnote 'Single-ended mode reduces the SNR by 6 dB if the unused input is grounded, by 3 dB if the unused input connects to  $V_{CM}$  (GAIN = 2).' to  $SNR$
  - Remove footnote 'Single-ended mode reduces the SNR by 6 dB if the unused input is grounded, by 3 dB if the unused input connects to  $V_{CM}$  (GAIN = 2).' from  $SNR$
  - Add min 60 dB to SFDR
  - Add typ 100 kHz to  $f_{PB}$
  - Add min 74 dB to  $SNR$
  - Change min value of  $SNR$  from 70 dB to 74 dB
  - Add min 70 dB to  $SNR$
  - Change min value of  $SNR$  from 65 dB to 70 dB
  - Add min 76 dB to  $SNR$
  - Change min value of  $SNR$  from 72 dB to 76 dB
  - Add typ 30 kHz to  $f_{PB}$
  - Change min value of  $ED_{GAIN}$  from -5 % to -3.5 %
  - Change min value of  $ED_{GAIN}$  from -0.1 % to -0.2 %
  - Change max value of  $ED_{GAIN}$  from 0.1 % to 0.2 %
  - Add footnote 'Recalibration needed in case of a temperature change > 20°C' to  $ED_{GAIN}$
  - Change max value of  $ED_{GAIN}$  from 5 % to 3.5 %
  - Change min value of  $ED_{OFF}$  from -350 mV to -100 mV
  - Add max 100 mV to  $ED_{OFF}$
  - Change typ value of  $ED_{OFF}$  from -150 mV to mV
  - Change note of  $R_{DAIN}$  from 'Exact value (+-1%) available in UCB' to 'Exact value ( $\pm 1\%$ ) available in UCB'
  - Add footnote 'The variation of the impedance between different channels is < 1.5%.' to  $R_{DAIN}$
  - Change note of  $SNR$  from ' $f_{PB} = 100\text{kHz}$ ' to ' $f_{PB} = 100 \text{ kHz}; V_{DDM} = \pm 5\%$ '
  - Change min value of  $SNR$  from 69 dB to 74 dB
  - Remove footnote '10 kHz only with 10MHz Modulator clock frequency reachable' from  $f_{PB}$
  - Add footnote '10 kHz only reachable with 10 MHz modulator clock frequency.' to  $f_{PB}$
  - Change note of  $SBA$  from '1,5 ...  $2 f_D$ ' to '1.5 ...  $2 f_D$ '
  - Remove footnote 'Derating factors:-2 dB in standard-performance mode.-3 dB for  $CMV = 10_B$ , i.e.  $V_{CM} = (V_{AREF} \pm 2\%) / 2.0$ .' from  $SBA$
  - Add footnote 'CIC3, FIR0, FIR1 filters enabled.' to  $SBA$
  - Change note of  $SBA$  from '2,5 ...  $OSR/2 f_D$ ' to '2.5 ...  $OSR/2 f_D$ '
  - Change note of  $SBA$  from '0,5 ...  $1 f_D$ ' to '0.5 ...  $1 f_D$ '
  - Change note of SFDR from ' $V_{CM} = 2.2\text{V}$ , DC coupled' to ' $V_{CM} = 2.2 \text{ V}$ , DC coupled;  $V_{DDM} = \pm 10\%$ '

**HistoryChanges from version version 0.6 to 0.7**

- Add footnote 'SFDR = 20 \* log(INL / 2<sup>N</sup>)' to *SFDR*
- Change description of *dVCM* from 'Common Mode Voltage Accuracy' to 'Common mode voltage accuracy'
- Change description of *dVCMH* from 'Commom mode hold voltage deviation' to 'Common mode hold voltage deviation'
- Change description of *I<sub>OZ5</sub>* from 'Positive reference pin leakage' to 'Positive reference *V<sub>AREF1</sub>* pin leakage'
- Change description of *I<sub>OZ6</sub>* from 'Negative reference pin leakage' to 'Negative reference *V<sub>AGND1</sub>* pin leakage'
- DSADC\_33V
  - Change note of *SNR* from '*f<sub>PB</sub>* = 30kHz' to '*f<sub>PB</sub>* = 30kHz; *V<sub>DDM</sub>* = ±5%'
  - Change note of *SNR* from '*f<sub>PB</sub>* = 50kHz' to '*f<sub>PB</sub>* = 50kHz; *V<sub>DDM</sub>* = ±5%'
  - Add min 45 dB to *SNR*
  - Add min 60 dB to *SNR*
  - Add min 55 dB to *SNR*
  - Add typ 63 dB to *SNR*
  - Add typ 66 dB to *SNR*
  - Add typ 68 dB to *SNR*
  - Add min 52 dB to SFDR
  - Change max value of *ED<sub>GAIN</sub>* from 0.1 % to 0.2 %
  - Add footnote 'Recalibration needed in case of a temperature change > 20°C.' to *ED<sub>GAIN</sub>*
  - Change note of *SBA* from '1,5 ... 2 *f<sub>D</sub>*' to '1.5 ... 2 *f<sub>D</sub>*'
  - Change note of *SBA* from '0,5 ... 1 *f<sub>D</sub>*' to '0.5 ... 1 *f<sub>D</sub>*'
  - Change note of *SBA* from '2,5 ... OSR/2 *f<sub>D</sub>*' to '2.5 ... OSR/2 *f<sub>D</sub>*'
  - Change note of SFDR from 'VCM = 2.2V, DC coupled' to '*V<sub>CM</sub>* = 2.2 V, DC coupled; *V<sub>DDM</sub>* = ±5%'
  - Change note of *SNR* from '*f<sub>PB</sub>* = 100kHz' to '*f<sub>PB</sub>* = 100kHz; *V<sub>DDM</sub>* = ±5%'
- Changes in table 'Class LP 5V' of Standard\_Pads
  - Change max value of *V<sub>ILHLP</sub>* from 2.85 V to 3.0 V
  - Change min value of *HYS<sub>LP</sub>* from 0.1 \* *V<sub>EXT/FLEX</sub>* V to 0.09 \* *V<sub>EXT/FLEX</sub>* V
  - Change min value of *HYS<sub>LP</sub>* from 0.08 \* *V<sub>EXT/FLEX</sub>* V to 0.075 \* *V<sub>EXT/FLEX</sub>* V
- Changes in table 'Class MPR 5V' of Standard\_Pads
  - Change min value of *HYS<sub>MPR</sub>* from 0.1 \* *V<sub>EXT/FLEX</sub>* V to 0.09 \* *V<sub>EXT/FLEX</sub>* V
  - Change min value of *HYS<sub>MPR</sub>* from 0.08 \* *V<sub>EXT/FLEX</sub>* V to 0.075 \* *V<sub>EXT/FLEX</sub>* V
- Changes in table 'Class I 3.3V' of Standard\_Pads
  - Change min value of *HYS<sub>I</sub>* from 0.047 \* *V<sub>EXT/FLEX</sub>* V to 0.045 \* *V<sub>EXT/FLEX</sub>* V
- Changes in table 'Class I 5V' of Standard\_Pads
  - Change min value of *HYS<sub>I</sub>* from 0.073 \* *V<sub>EXT/FLEX</sub>* V to 0.07 \* *V<sub>EXT/FLEX</sub>* V
  - Change min value of *HYS<sub>I</sub>* from 0.1 \* *V<sub>EXT/FLEX</sub>* V to 0.09 \* *V<sub>EXT/FLEX</sub>* V
  - Change min value of *HYS<sub>I</sub>* from 0.08 \* *V<sub>EXT/FLEX</sub>* V to 0.075 \* *V<sub>EXT/FLEX</sub>* V
  - Change max value of *V<sub>ILHI</sub>* from 2.85 V to 3.0 V
- Changes in table 'Class S' of Standard\_Pads
  - Change note of *I<sub>OZS</sub>* from 'Analog Inputs overlaid with GPIO functions or pull down diagnosis or DSADC inputs' to 'Analog Inputs with pull down diagnostics'
- Changes in table 'Class MP 5V' of Standard\_Pads
  - Change min value of *HYS<sub>MP</sub>* from 0.1 \* *V<sub>EXT/FLEX</sub>* V to 0.09 \* *V<sub>EXT/FLEX</sub>* V

**HistoryChanges from version version 0.6 to 0.7**

- Change min value of  $HYSMP$  from  $0.08 * V_{EXT/FLEX}$  V to  $0.075 * V_{EXT/FLEX}$  V
- Change max value of  $V_{ILHMP}$  from 2.85 V to 3.0 V
- Changes in table 'Class MP+ 5V' of Standard\_Pads
  - Change min value of  $HYSMPP$  from  $0.08 * V_{EXT/FLEX}$  V to  $0.075 * V_{EXT/FLEX}$  V
  - Change min value of  $HYSMPP$  from  $0.1 * V_{EXT/FLEX}$  V to  $0.09 * V_{EXT/FLEX}$  V
  - Change max value of  $V_{ILHMPP}$  from 2.85 V to 3.0 V
- Changes in table 'Class F' of Standard\_Pads
  - Add footnote 'For currents smaller than the  $I_{OL/OH}$  from the test condition the defined Max. value stays unchanged.' to  $R_{DSONMPRW}$
  - Add footnote 'For currents smaller than the  $I_{OL/OH}$  from the test condition the defined Max. value stays unchanged.' to  $R_{DSONMPRM}$
  - Add footnote 'For currents smaller than the  $I_{OL/OH}$  from the test condition the defined Max. value stays unchanged.' to  $R_{DSONMPRS}$
  - Add footnote 'Rise / fall times are defined 10% - 90% of  $V_{EXT/FLEX}$ .' to  $t_{MPR}$
- Changes in table 'Master Mode Timing, LVDSM output pads for data and clock' of QSPI\_ED/3.3V
  - Change min value of  $t_{52}$  from 37 ns to 20 ns
- Absolute Maximum Ratings
  - Change note of  $T_{ST}$  from 'upto 65h @  $T_J = 150^{\circ}C$ ' to 'upto 65h @  $T_J = 150^{\circ}C$ ; upto 15h @  $T_J = 170^{\circ}C$ '
  - Change max value of  $T_{ST}$  from 150 °C to 170 °C
- Operating Conditions
  - Change description of  $V_{DDP3}$  from 'Digital supply voltage for LVDSH and A2 apds' to 'Digital supply voltage for LVDSH and A2 pads'
  - Add footnote 'All  $V_{DDP3}$  pins shall be connected together externally on the PCB.' to  $V_{DDP3}$
  - Change min value of  $V_{DDPPA}$  from 0.7 V to 0.72 V
- Changes in table 'Master Mode Timing, LVDSM output pads for data and clock' of QSPI/3.3V
  - Change min value of  $t_{52}$  from 37 ns to 20 ns
- Changes in table 'Master Mode Weak output pads' of QSPI/5V
  - Add footnote 'Documented value is valid for master transmit or slave receive only. For full duplex the external SPI counterpart timing has to be taken into account.' to  $t_{50}$
- Changes in table 'Receive Parameters' of ERAY
  - Change description of  $t_{dCCTxAsymAccept15}$  from 'Acceptance of asymmetry at receiving part' to 'Acceptance of asymmetry at receiving part'
  - Change description of  $t_{dCCTxAsymAccept25}$  from 'Acceptance of asymmetry at receiving part' to 'Acceptance of asymmetry at receiving part'
- Power Supply
  - Update footnote of *Power Supply* to ' A single converter instance of VADC unit consumes 2 mA.'
  - Change description of  $I_{DDx3RAIL}$  from ' $\Sigma$  Sum of 3.3 V supply currents' to ' $\Sigma$  Sum of 3.3 V supply currents without pad activity'
  - Change note of  $I_{EXT/FLEX}$  from 'real power pattern with port activity absent; PORST output inactive.' to 'real power pattern; PORST output inactive.'
  - Change description of  $I_{DDIO}$  from 'Sum of  $I_{EXT}$  and  $I_{FLEX}$  supply current' to 'Sum of  $I_{EXT}$  and  $I_{FLEX}$  supply current without pad activity'
  - Change description of  $I_{DDP3}$  from ' $I_{DDP3}$  supply current with no pad activity' to ' $I_{DDP3}$  supply current without pad activity'

**HistoryChanges from version version 0.7 to 1.0**

- Change max value of  $I_{DDM}$  from 26 mA to 30 mA
- Change max value of  $I_{DDM}$  from 18 mA to 14 mA
- Change max value of  $I_{DDM}$  from 52 mA to 59 mA
- Change max value of  $I_{DDM}$  from 24 mA to 17 mA
- Changes in table 'LVDSH - IEEE standard LVDS general purpose link (GPL)' of LVDSH
  - Change description of  $t_{fall20}$  from 'Fall time (20% - 80%)' to 'Fall time'
  - Change description of  $t_{rise20}$  from 'Rise time (20% - 80%)' to 'Rise time'
- Changes in table 'LVDSH - IEEE standard LVDS reduced link (REDL)' of LVDSH
  - Change description of  $t_{rise10}$  from 'Vod Rise time (10% - 90%)' to ' $V_{OD}$  Rise time'
  - Change description of  $t_{fall10}$  from 'Vod Fall time (10% - 90%)' to ' $V_{OD}$  Fall time'
- Changes in table 'LVDSH - Reduced TX and RX (RED)' of LVDSH
  - Change description of  $t_{rise}$  from 'Rise time (10% - 90%)' to 'Rise time'
  - Change description of  $t_{fall}$  from 'Fall time (10% - 90%)' to 'Fall time'
  - Add footnote 'Rise / fall times are defined for 10% - 90% of  $V_{OD}$ ' to  $t_{fall}$
  - Add footnote 'Rise / fall times are defined for 20% - 80% of  $V_{OD}$ ' to  $t_{rise20}$
  - Add footnote 'Rise / fall times are defined for 10% - 90% of  $V_{OD}$ ' to  $t_{rise}$
  - Add footnote 'Rise / fall times are defined for 20% - 80% of  $V_{OD}$ ' to  $t_{fall20}$
  - Add footnote 'Rise / fall times are defined for 10% - 90% of  $V_{OD}$ ' to  $t_{rise10}$
  - Add footnote 'Rise / fall times are defined for 10% - 90% of  $V_{OD}$ ' to  $t_{fall10}$

## 4.2 Changes from version version 0.7 to 1.0

- Package Chapter
  - update information for VADC functions 'with pull down diagnostics' and 'MD', no change in pinning
  - correct for P20.2 PU1 to PU
  - add additional pin VSSM at position 100 to TC270 Bare Die pin list, shift following pins accordingly
  - add additional pin VDDM at position 104 to TC270 Bare Die pin list, shift following pins accordingly
  - remove 'P33.8: Emergency Stop can be overruled if this pin is used as safety output pin (SMUFSP)'
  - add 'Supply (the Exposed Pad is also considered as VSS and shall be connected to ground)' to Vx type definition
- Absolute Maximum Ratings
  - Add footnote 'Voltages below  $V_{INmin}$  have no Impact to the device reliabilty as Long as the times and currents defined in section Pin Reliability in Overload for the affected pad(s) are not violated.' to  $V_{INA}$
  - Add footnote 'Voltages below  $V_{INmin}$  have no Impact to the device reliabilty as Long as the times and currents defined in section Pin Reliability in Overload for the affected pad(s) are not violated.' to  $V_{INB}$
- Changes in table 'Overload Parameters' of Overload
  - Remove  $I_{INSA}$
- Class S
  - Change footnote from 'VILSD is implemented to ensure J2716 specification. It can't be guaranteed that it suppresses switching due to external system noise if pads configured with Speed grade 1 setting (PDx.1=0 and PDx.0=0) is not configured for all of the two physically neighbors left and right of the used SENT input

**HistoryChanges from version version 0.7 to 1.0**

pin.' to 'VILSD is implemented to ensure J2716 specification. For details of dedicated pins please see AP32286 for details.'

- Changes in table 'Class A2' of Standard\_Pads
  - Change note of  $V_{IHA2}$  from 'TTL;else' to 'TTL;valid for all A2 pads except TMS/DAP1, TRST, and TCK/DAP0'
  - Change note of  $V_{ILA2}$  from 'TTL;else' to 'TTL;valid for all A2 pads except TMS/DAP1, TRST, and TCK/DAP0'
- VADC
  - Change max value of  $Q_{CONV}$  from 20 pC to 75 pC
  - Change max value of  $Q_{CONV}$  from 10 pC to 22 pC
  - Change typ value of  $Q_{CONV}$  from 14 pC to 50 pC
  - Change note of  $Q_{CONV}$  from '3 pC' to '10 pC'
  - Change note of  $I_{OZ3}$  from '-2  $\mu$ A' to '-2.85  $\mu$ A'
  - Change max value of  $EN_{RMS}$  from 0.75 LSB to 0.8 LSB
  - Change max value of  $R_{AIN}$  from 1.6 kOhm to 1.5 kOhm
  - Remove  $C_{AREFT}$
- VADC\_33V
  - Change max value of  $Q_{CONV}$  from 15 pC to 50 pC
  - Change note of  $Q_{CONV}$  from '8 pC' to '17 pC'
  - Change typ value of  $Q_{CONV}$  from 7 pC to 35 pC
  - Change type of  $Q_{CONV}$  from SR to CC
  - Change typ value of  $Q_{CONV}$  from 3 pC to 8 pC
  - Change note of  $EN_{RMS}$  from '1.5 LSB' to '1.7 LSB'
  - Change note of  $EN_{RMS}$  from "target" to ""
  - Remove  $C_{AREFT}$
- DSADC
  - Change note of  $SNR$  from ' $f_{PB} = 30$  kHz;  $V_{DDM} = \pm 5\%$ ' to ' $f_{PB} = 30$  kHz;  $V_{DDM} = \pm 5\%$ ;  $f_{MOD} = 20$  MHz; GAIN = 1'
  - Change note of  $SNR$  from ' $f_{PB} = 50$  kHz;  $V_{DDM} = \pm 5\%$ ' to ' $f_{PB} = 50$  kHz;  $V_{DDM} = \pm 5\%$ ;  $f_{MOD} = 20$  MHz; GAIN = 1'
  - Change max value of  $I_{REF}$  from 5.5  $\mu$ A to 6.3  $\mu$ A
  - Change note of  $ED_{GAIN}$  from 'Target, calibrated' to 'calibrated; GAIN = 1; MODCFG.INCFGx=01'
  - Change note of  $SNR$  from ' $f_{PB} = 100$  kHz;  $V_{DDM} = \pm 5\%$ ' to ' $f_{PB} = 100$  kHz;  $V_{DDM} = \pm 5\%$ ;  $f_{MOD} = 20$  MHz; GAIN = 1'
  - Change note of  $SNR$  from ' $f_{PB} = 50$  kHz;  $V_{DDM} = \pm 10\%$ ' to ' $f_{PB} = 50$  kHz;  $V_{DDM} = \pm 10\%$ ;  $f_{MOD} = 20$  MHz; GAIN = 1'
  - Change note of  $SNR$  from ' $f_{PB} = 100$  kHz;  $V_{DDM} = \pm 10\%$ ' to ' $f_{PB} = 100$  kHz;  $V_{DDM} = \pm 10\%$ ;  $f_{MOD} = 20$  MHz; GAIN = 1'
  - Change note of  $SNR$  from ' $f_{PB} = 30$  kHz;  $V_{DDM} = \pm 10\%$ ' to ' $f_{PB} = 30$  kHz;  $V_{DDM} = \pm 10\%$ ;  $f_{MOD} = 20$  MHz; GAIN = 1'
  - Remove max parameter  $SFDR$  from ' $V_{CM} = 2.2$  V, DC coupled;  $V_{DDM} = \pm 5\%$ '
  - Add footnote 'The total DC error for the uncalibrated case can be calculated by the geometric addition of  $ED_{GAIN}$  and  $ED_{OFF}$ ' to  $ED_{OFF}$
  - Remove footnote 'Systematic offset shift' from  $ED_{OFF}$
  - Remove old footnote 9)

**History Changes from version version 0.7 to 1.0**

- Add footnote 'The defined limits are only valid if the following condition is not applicable:  $T_J > 150^\circ\text{C}$  and  $V_{VAREF} > V_{DDM}$ .' to *SNR*
- Change footnote from 'SFDR =  $20 * \log(\text{INL} / 2^{\text{Superscript}>N</Superscript>})$ ' to 'SFDR =  $20 * \log(\text{INL} / 2^{\text{Superscript}>N</Superscript>})$ ; N = amount of bits'
- DSADC\_33V
  - Change note of *SNR* from ' $f_{PB} = 30\text{kHz}; V_{DDM} = \pm 5\%$ ' to ' $f_{PB} = 30\text{kHz}; V_{DDM} = \pm 5\%; f_{MOD} = 20\text{ MHz}; \text{GAIN} = 1$ '
  - Change note of *SNR* from ' $f_{PB} = 50\text{kHz}; V_{DDM} = \pm 5\%$ ' to ' $f_{PB} = 50\text{kHz}; V_{DDM} = \pm 5\%; f_{MOD} = 20\text{ MHz}; \text{GAIN} = 1$ '
  - Change note of  $I_{REF}$  from '5.5  $\mu\text{A}$ ' to '5.8  $\mu\text{A}$ '
  - Change min value of  $ED_{OFF}$  from -350 mV to -100 mV
  - Add max 100 mV to  $ED_{OFF}$
  - Change note of  $ED_{GAIN}$  from 'Target, calibrated' to 'calibrated; GAIN = 1; MODCFG.INCFGx=01'
  - Change note of *SNR* from ' $f_{PB} = 30\text{kHz}; V_{DDM} = \pm 10\%$ ' to ' $f_{PB} = 30\text{kHz}; V_{DDM} = \pm 10\%; f_{MOD} = 20\text{ MHz}; \text{GAIN} = 1$ '
  - Change note of *SNR* from ' $f_{PB} = 30\text{kHz}; V_{DDM} = \pm 5\%$ ' to ' $f_{PB} = 30\text{kHz}; V_{DDM} = \pm 5\%; f_{MOD} = 20\text{ MHz}; \text{GAIN} = 1$ '
  - Change note of *SNR* from ' $f_{PB} = 50\text{kHz}; V_{DDM} = \pm 5\%$ ' to ' $f_{PB} = 50\text{kHz}; V_{DDM} = \pm 5\%; f_{MOD} = 20\text{ MHz}; \text{GAIN} = 1$ '
  - Change note of *SNR* from ' $f_{PB} = 50\text{kHz}; V_{DDM} = \pm 10\%$ ' to ' $f_{PB} = 50\text{kHz}; V_{DDM} = \pm 10\%; f_{MOD} = 20\text{ MHz}; \text{GAIN} = 1$ '
  - Change note of *SNR* from ' $f_{PB} = 100\text{kHz}; V_{DDM} = \pm 5\%$ ' to ' $f_{PB} = 100\text{kHz}; V_{DDM} = \pm 5\%; f_{MOD} = 20\text{ MHz}; \text{GAIN} = 1$ '
  - Change note of *SNR* from ' $f_{PB} = 100\text{kHz}; V_{DDM} = \pm 10\%$ ' to ' $f_{PB} = 100\text{kHz}; V_{DDM} = \pm 10\%; f_{MOD} = 20\text{ MHz}; \text{GAIN} = 1$ '
  - Change note of  $I_{OZ5}$  from 'all ADCs disabled' to ''
  - Change note of  $I_{OZ6}$  from 'all ADCs disabled' to ''
  - Add footnote 'The total DC error for the uncalibrated case can be calculated by the geometric addition of  $ED_{GAIN}$  and  $ED_{OFF}$ ' to  $ED_{OFF}$
  - Remove footnote 'Systematic offset shift' from  $ED_{OFF}$
  - Remove old footnote 9)
  - Add footnote 'The defined limits are only valid if the following condition is not applicable:  $T_J > 150^\circ\text{C}$  and  $V_{VAREF} > V_{DDM}$ .' to *SNR*
  - Change footnote from 'SFDR =  $20 * \log(\text{INL} / 2^{\text{Superscript}>N</Superscript>})$ ' to 'SFDR =  $20 * \log(\text{INL} / 2^{\text{Superscript}>N</Superscript>})$ ; N = amount of bits'
- MHz Oscillator
  - Change support OSC\_XTAL frequency from 8 MHz to 24 MHz to 8 MHz to 40 MHz
- Power Supply
  - Change note of  $I_{DDM}$  from 'real pattern; current for VADC only;' to 'real pattern; current for VADC only'
- EVR13 SMPS
  - Update wording of footnote 2)
  - Add footnote 'If frequency spreading (SDFREQSPRD = 1) is activated, an additional ripple of 1% need to be considered.'
- Reset Timings
  - Change note of  $t_{BP}$  from '1.1 ms' to '1.11 ms'
  - Remove footnote 2) from  $t_{BP}$  max limit 2.5ms
  - Update wording of footnote 4)
- Changes in table 'I2C Standard Mode Timing' of I2C

- Change predicate of  $t_7$  from max to min
- Changes in Package outline
  - Add information about epad size
  - Add section TC270 Carrier Tape

#### 4.3 Changes from version version 1.0 to 1.1

- VADC
  - Add parameter  $t_{WU}$
  - Add parameter  $R_{MDU}$
  - Add parameter  $R_{MDD}$

#### 4.4 Changes from version version 1.1 to 1.2

- Add Package Version LF-BGA-292-10

[www.infineon.com](http://www.infineon.com)

Published by Infineon Technologies AG

## Looking for pricing, stock, or lifecycle information?

Click below to explore more details on WIN SOURCE:

- ⊖ [View TC275TP64F200WDCKXUMA1 on WIN SOURCE](#)
- ⊖ [Infineon Technologies Information](#)

## Optimize Your Supply Chain with WIN SOURCE Solutions

- ✓ Global Sourcing Solution
- ✓ Obsolete Management
- ✓ Cost Control Management
- ✓ Shortage Management
- ✓ Alternative Solution
- ✓ Excess Inventory Management