



**THE DATASHEET OF
QEB373ZR**



Subminiature Plastic Infrared Emitting Diode

QEB373

Features

- T-3/4 (2 mm) Surface Mount Package
- Lead Form Options: Gullwing, Yoke, Z-Bend
- Narrow Emission Angle, 24°
- Wavelength = 875 nm, AlGaAs
- Clear Lens
- Matched Photosensor: QSB363
- High Radiant Intensity
- This is a Pb-Free and Halide Free Device

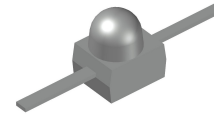

T-3/4, 2.50 × 2.00
CASE 100EE

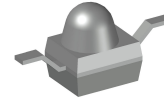

T-3/4, 2.50 × 2.00
CASE 100EG

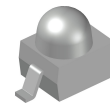

T-3/4, 2.50 × 2.00
CASE 100EF

MAXIMUM RATINGS (T_A = 25°C unless otherwise noted)

Symbol	Parameter	Value	Unit
T _{OPR}	Operating Temperature	-40 to +100	°C
T _{STG}	Storage Temperature	-40 to +100	°C
T _{SOL-I}	Soldering Temperature (Iron) (Notes 2, 3, 4)	240 for 5 s	°C
T _{SOL-F}	Soldering Temperature (Flow) (Notes 2, 3)	260 for 10 s	°C
I _F	Continuous Forward Current	50	mA
V _R	Reverse Voltage	5	V
P _D	Power Dissipation (Note 1)	100	mW

Stresses exceeding those listed in the Maximum Ratings table may damage the device. If any of these limits are exceeded, device functionality should not be assumed, damage may occur and reliability may be affected.

NOTES:

1. Derate power dissipation linearly 1.33 mW/°C above 25°C.
2. RMA flux is recommended.
3. Methanol or isopropyl alcohols are recommended as cleaning agents.
4. Soldering iron 1/16" (1.6 mm) minimum from housing.

SCHEMATIC

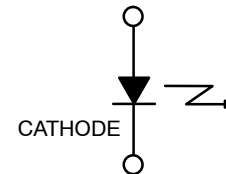

ORDERING INFORMATION

See detailed ordering and shipping information on page 3 of this data sheet.

ELECTRICAL CHARACTERISTICS (T_A = 25°C)

Symbol	Parameter	Test Conditions	Min	Typ	Max	Unit
λ _P	Peak Emission Wavelength	I _F = 100 mA	-	875	-	nm
Θ	Emission Angle	I _F = 100 mA	-	±12	-	°
V _F	Forward Voltage	I _F = 100 mA, t _p = 20 ms	-	-	1.7	V
I _R	Reverse Current	V _R = 5 V	-	-	100	μA
I _e	Radiant Intensity	I _F = 100 mA, t _p = 20 ms	16	-	-	mW/sr
t _r	Rise Time	I _F = 100 mA	-	800	-	ns
t _f	Fall Time	t _p = 20 ms	-	800	-	ns

Product parametric performance is indicated in the Electrical Characteristics for the listed test conditions, unless otherwise noted. Product performance may not be indicated by the Electrical Characteristics if operated under different conditions.

TYPICAL PERFORMANCE CURVES

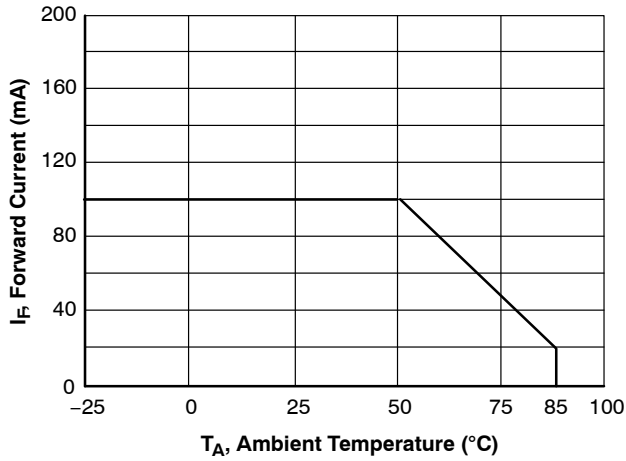

Figure 1. Maximum Forward Current vs. Temperature

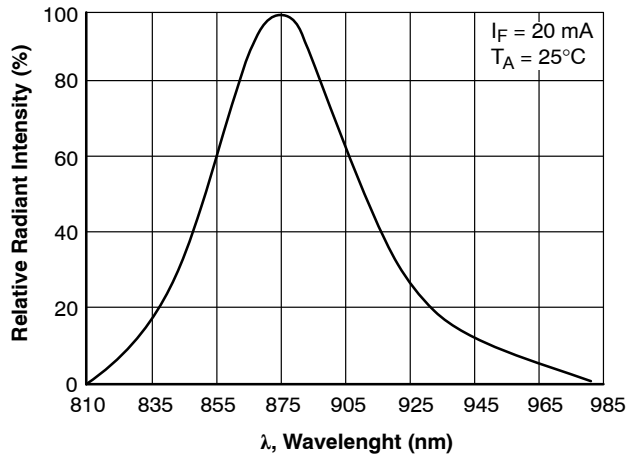

Figure 2. Relative Radiant Intensity vs. Wavelength

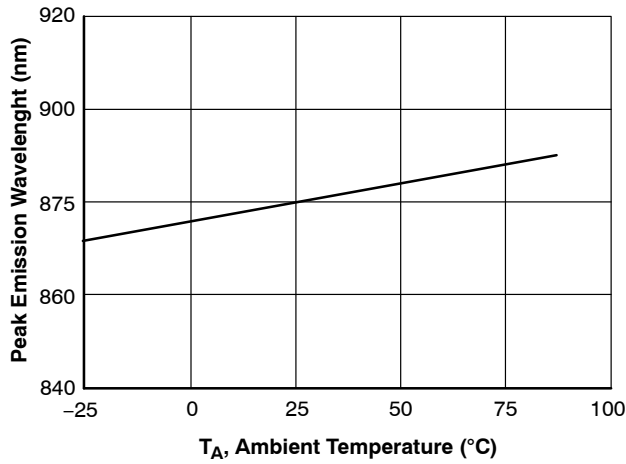

Figure 3. Peak Emission Wavelength vs. Ambient Temperature

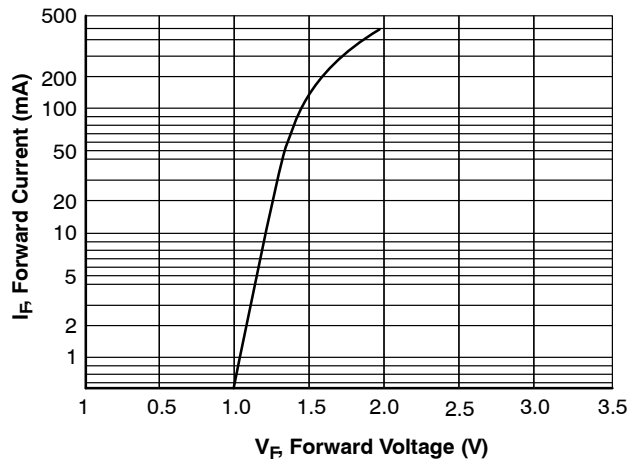

Figure 4. Forward Current vs. Forward Voltage

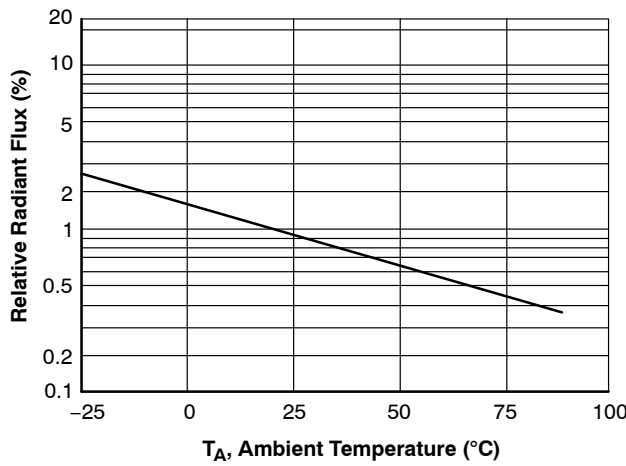

Figure 5. Relative Radiant Flux vs. Ambient Temperature

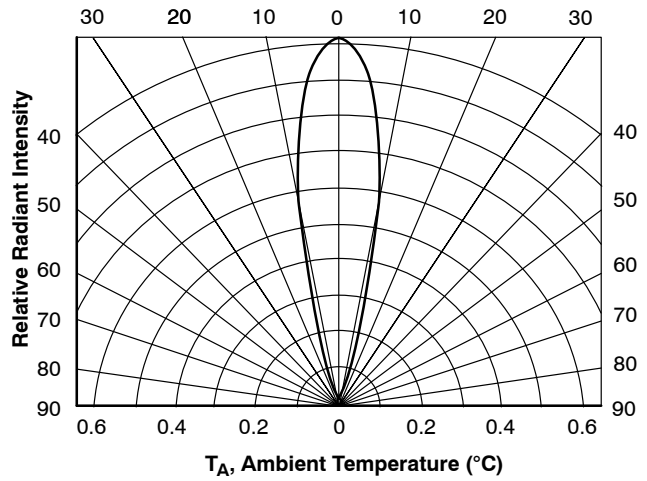

Figure 6. Relative Radiant Intensity vs. Angular Displacement

QEB373

ORDERING INFORMATION

Part Number	Package	Shipping [†]
QEB373	T-3/4, 2.50 × 2.00 (Case 100EE) (Pb-Free)	1000 Units / Bulk
QEB373GR	T-3/4, 2.50 × 2.00 (Case 100EF) (Pb-Free)	1000 / Tape & Reel
QEB373ZR	T-3/4, 2.50 × 2.00 (Case 100EG) (Pb-Free)	1000 / Tape & Reel

[†]For information on tape and reel specifications, including part orientation and tape sizes, please refer to our Tape and Reel Packaging Specifications Brochure, [BRD8011/D](#).

MECHANICAL CASE OUTLINE
PACKAGE DIMENSIONS

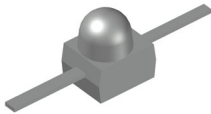

T-3/4 2.50x2.00
CASE 100EE
ISSUE O

DATE 14 SEP 2023

NOTES:

1. CONTROLLING DIMENSIONS: MILLIMETERS
2. DIMENSIONS DO NOT INCLUDE MOLD FLASH OR BURRS.
3. 2MM LED RP

DIM	MILLIMETERS		
	MIN.	NOM.	MAX.
A	2.50	2.70	2.90
A2	1.30	1.40	1.50
A3	1.30	1.40	1.50
A4	0.60 REF		
b	0.45	0.55	0.65
b1	0.35	0.45	0.55
c	0.10	0.15	0.25
D	2.30	2.50	2.70
E	1.80	2.00	2.20
L	7.00	---	---
øD	1.70	1.90	2.10

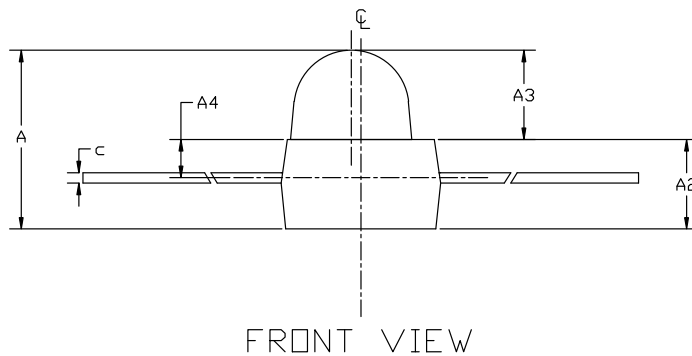
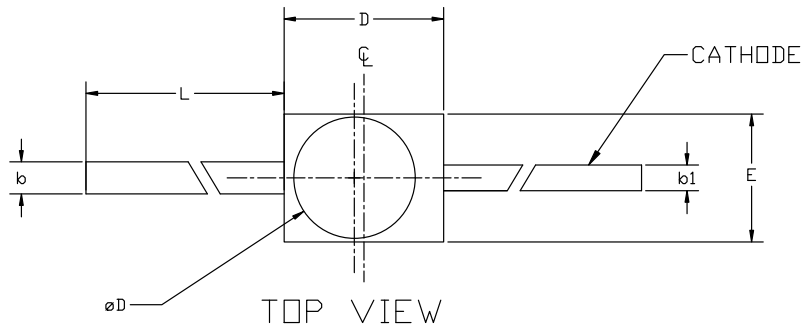

DOCUMENT NUMBER:	98AON57116H	Electronic versions are uncontrolled except when accessed directly from the Document Repository. Printed versions are uncontrolled except when stamped "CONTROLLED COPY" in red.
DESCRIPTION:	T-3/4 2.50x2.00	PAGE 1 OF 1

onsemi and **ONSEMI** are trademarks of Semiconductor Components Industries, LLC dba **onsemi** or its subsidiaries in the United States and/or other countries. **onsemi** reserves the right to make changes without further notice to any products herein. **onsemi** makes no warranty, representation or guarantee regarding the suitability of its products for any particular purpose, nor does **onsemi** assume any liability arising out of the application or use of any product or circuit, and specifically disclaims any and all liability, including without limitation special, consequential or incidental damages. **onsemi** does not convey any license under its patent rights nor the rights of others.

MECHANICAL CASE OUTLINE
PACKAGE DIMENSIONS



T-3/4 2.50x2.00
CASE 100EF
ISSUE O

DATE 14 SEP 2023

NOTES:

1. CONTROLLING DIMENSIONS: MILLIMETERS
2. DIMENSIONS DO NOT INCLUDE MOLD FLASH OR BURRS.
3. 2MM GULLWING LED RP

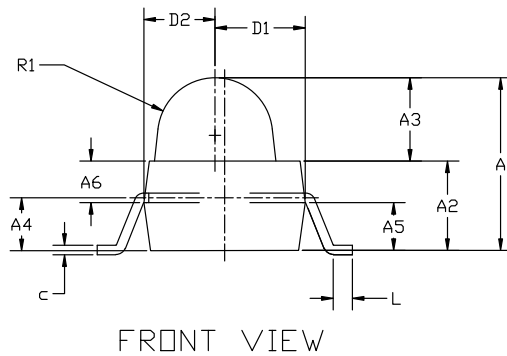
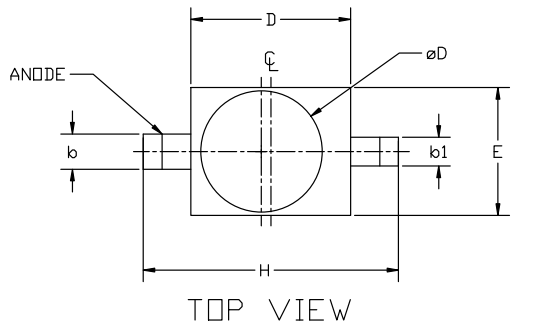

DIM	MILLIMETERS		
	MIN.	NOM.	MAX.
A	2.50	2.70	2.90
A2	1.30	1.40	1.50
A3	1.20	1.30	1.40
A4	0.75	0.85	0.95
A5	0.65	0.75	0.85
A6	0.55	0.65	0.75
b	0.45	0.55	0.65
b1	0.35	0.45	0.55
c	0.10	0.15	0.20
D	2.30	2.50	2.70
D1	1.20	1.40	1.60
D2	0.90	1.10	1.30
E	1.80	2.00	2.20
H	3.80	4.00	4.20
L	0.20	0.30	0.40
∅D	1.70	1.90	2.10
R1	0.70	0.80	0.90

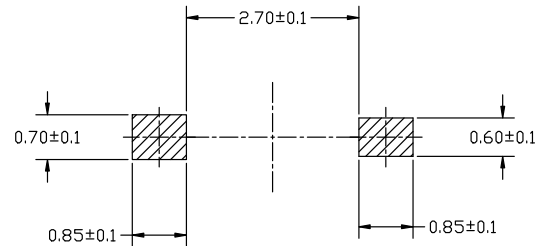

* For additional information on our Pb-Free strategy and soldering details, please download the ON Semiconductor Soldering and Mounting Techniques Reference Manual, SOLDERRM/D.

DOCUMENT NUMBER:	98AON57117H	Electronic versions are uncontrolled except when accessed directly from the Document Repository. Printed versions are uncontrolled except when stamped "CONTROLLED COPY" in red.
DESCRIPTION:	T-3/4 2.50x2.00	PAGE 1 OF 1

onsemi and ONSEMI are trademarks of Semiconductor Components Industries, LLC dba onsemi or its subsidiaries in the United States and/or other countries. onsemi reserves the right to make changes without further notice to any products herein. onsemi makes no warranty, representation or guarantee regarding the suitability of its products for any particular purpose, nor does onsemi assume any liability arising out of the application or use of any product or circuit, and specifically disclaims any and all liability, including without limitation special, consequential or incidental damages. onsemi does not convey any license under its patent rights nor the rights of others.

MECHANICAL CASE OUTLINE

PACKAGE DIMENSIONS

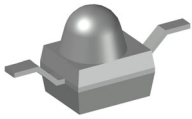

T-3/4 2.50x2.00
CASE 100EG
ISSUE O

DATE 14 SEP 2023

NOTES:

1. CONTROLLING DIMENSIONS: MILLIMETERS
2. DIMENSIONS DO NOT INCLUDE MOLD FLASH OR BURRS.
3. 2MM ZBEND LED RP.

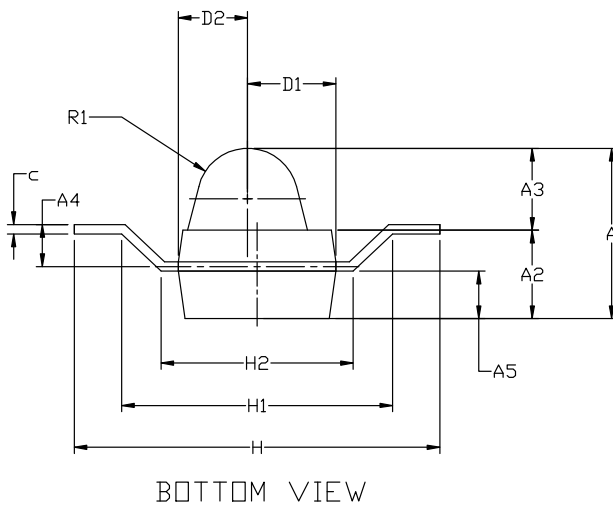
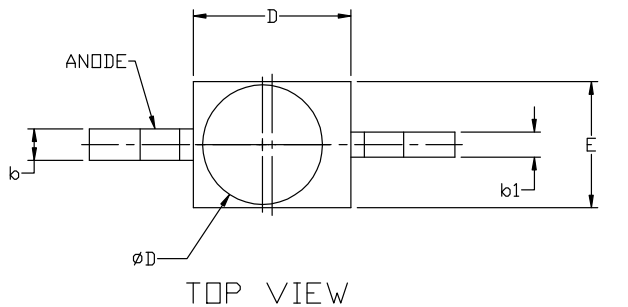

DIM	MILLIMETERS		
	MIN.	NOM.	MAX.
A	2.500	2.700	2.900
A2	1.300	1.400	1.500
A3	1.200	1.300	1.400
A4	0.550	0.650	0.750
A5	0.650	0.750	0.850
b	0.450	0.550	0.650
b1	0.350	0.450	0.550
c	0.100	0.150	0.200
D	2.300	2.500	2.700
D1	1.200	1.400	1.600
D2	0.900	1.100	1.300
E	1.800	2.000	2.200
H	5.600	5.800	6.000
H1	4.100	4.300	4.500
H2	2.850	3.050	3.250
øD	1.700	1.900	2.100
R1	0.700	0.800	0.900

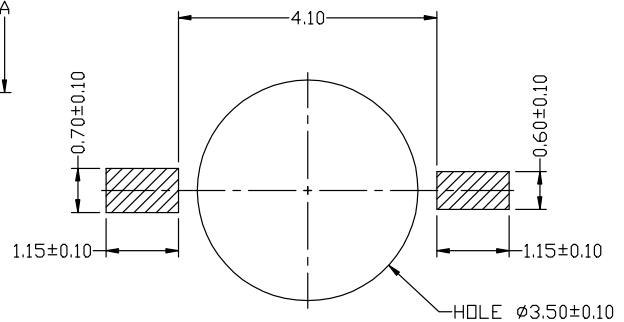

*FOR ADDITIONAL INFORMATION ON OUR Pb-FREE STRATEGY AND SOLDERING DETAILS, PLEASE DOWNLOAD THE ON SEMICONDUCTOR SOLDERING AND MOUNTING TECHNIQUES REFERENCE MANUAL, SOLDERRM/D.

DOCUMENT NUMBER:	98AON57118H	Electronic versions are uncontrolled except when accessed directly from the Document Repository. Printed versions are uncontrolled except when stamped "CONTROLLED COPY" in red.
DESCRIPTION:	T-3/4 2.50x2.00	PAGE 1 OF 1

onsemi and ONSEMI are trademarks of Semiconductor Components Industries, LLC dba onsemi or its subsidiaries in the United States and/or other countries. onsemi reserves the right to make changes without further notice to any products herein. onsemi makes no warranty, representation or guarantee regarding the suitability of its products for any particular purpose, nor does onsemi assume any liability arising out of the application or use of any product or circuit, and specifically disclaims any and all liability, including without limitation special, consequential or incidental damages. onsemi does not convey any license under its patent rights nor the rights of others.

onsemi, **Onsemi**, and other names, marks, and brands are registered and/or common law trademarks of Semiconductor Components Industries, LLC dba "**onsemi**" or its affiliates and/or subsidiaries in the United States and/or other countries. **onsemi** owns the rights to a number of patents, trademarks, copyrights, trade secrets, and other intellectual property. A listing of **onsemi**'s product/patent coverage may be accessed at www.onsemi.com/site/pdf/Patent-Marking.pdf. **onsemi** reserves the right to make changes at any time to any products or information herein, without notice. The information herein is provided "as-is" and **onsemi** makes no warranty, representation or guarantee regarding the accuracy of the information, product features, availability, functionality, or suitability of its products for any particular purpose, nor does **onsemi** assume any liability arising out of the application or use of any product or circuit, and specifically disclaims any and all liability, including without limitation special, consequential or incidental damages. Buyer is responsible for its products and applications using **onsemi** products, including compliance with all laws, regulations and safety requirements or standards, regardless of any support or applications information provided by **onsemi**. "Typical" parameters which may be provided in **onsemi** data sheets and/or specifications can and do vary in different applications and actual performance may vary over time. All operating parameters, including "Typicals" must be validated for each customer application by customer's technical experts. **onsemi** does not convey any license under any of its intellectual property rights nor the rights of others. **onsemi** products are not designed, intended, or authorized for use as a critical component in life support systems or any FDA Class 3 medical devices or medical devices with a same or similar classification in a foreign jurisdiction or any devices intended for implantation in the human body. Should Buyer purchase or use **onsemi** products for any such unintended or unauthorized application, Buyer shall indemnify and hold **onsemi** and its officers, employees, subsidiaries, affiliates, and distributors harmless against all claims, costs, damages, and expenses, and reasonable attorney fees arising out of, directly or indirectly, any claim of personal injury or death associated with such unintended or unauthorized use, even if such claim alleges that **onsemi** was negligent regarding the design or manufacture of the part. **onsemi** is an Equal Opportunity/Affirmative Action Employer. This literature is subject to all applicable copyright laws and is not for resale in any manner.

ADDITIONAL INFORMATION

TECHNICAL PUBLICATIONS:

Technical Library: www.onsemi.com/design/resources/technical-documentation
onsemi Website: www.onsemi.com

ONLINE SUPPORT: www.onsemi.com/support

For additional information, please contact your local Sales Representative at www.onsemi.com/support/sales

Looking for pricing, stock, or lifecycle information?

Click below to explore more details on WIN SOURCE:

 [View QEB373ZR on WIN SOURCE](#)

 [ON Semiconductor](#) Information

Optimize Your Supply Chain with WIN SOURCE Solutions

-  Global Sourcing Solution
-  Obsolete Management
-  Cost Control Management
-  Shortage Management
-  Alternative Solution
-  Excess Inventory Management