



**THE DATASHEET OF
PI6C49X0202WIE**



PI6C49X0202

Low Skew, 1-To-2 LVCMOS/LVTTL Fanout Buffer

Description

The DIODES PI6C49X0202 is a low skew, 1-to-2 LVCMOS/LVTTL High Performance Fanout Buffer. The PI6C49X0202 has a single ended clock input. The single ended clock input accepts LVCMOS or LVTTL input levels. The PI6C49X0202 features a pair of LVCMOS/LVTTL outputs. Guaranteed output and part-to-part skew characteristics make the PI6C49X0202 ideal for clock distribution applications demanding well defined performance and repeatability.

Block Diagram

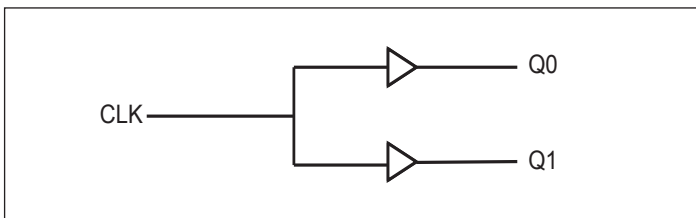

Features

- 2 LVCMOS/LVTTL Outputs
- LVCMOS/LVTTL Clock Input Accepts LVCMOS or LVTTL Input Levels
- Maximum Output Frequency: 250MHz
- Output Skew: 25ps (typical)
- Part-to-Part Skew: 250ps (typical)
- Full 3.3V, 2.5V Operation Modes
- Ambient Operating Temperature: -40°C to 85°C
- Totally Lead-Free & Fully RoHS Compliant (Notes 1 & 2)
- Halogen and Antimony Free. “Green” Device (Note 3)
- For automotive applications requiring specific change control (i.e. parts qualified to AEC-Q100/101/104/200, PPAP capable, and manufactured in IATF 16949 certified facilities), please [contact us](mailto:contact@diodes.com) or your local Diodes representative.
<https://www.diodes.com/quality/product-definitions/>
- Packaging (Pb-free & Green):
 - 8-pin, SOIC (W)

Pin Configuration

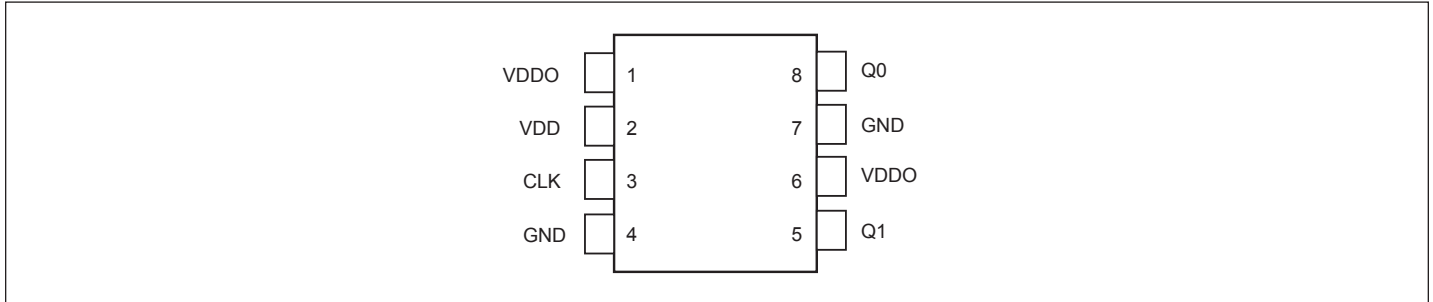

Pin Descriptions

Pin#	Pin Name	Type		Pin Description
1, 6	VDDO	Power		Output supply pins.
2	VDD	Power		Core supply pin.
3	CLK	Input	Pulldown	LVC MOS/LVTTL clock input.
4, 7	GND	Power		Power supply ground.
5	Q1	Output		Single clock output. LVC MOS/LVTTL interface levels.
8	Q0	Output		Single clock output. LVC MOS/LVTTL interface levels.

Note: Pulldown refer to internal input resistors, typical values in Pin Characteristics table.

Pin Characteristics

Symbol	Parameter	Min.	Typ.	Max.	Units
C_N	Capacitance		4		pF
$R_{PULLDOWN}$	Input Pulldown Resistor		51		k Ω
R_{OUT}	Output Impedance	5	7	12	Ω

Maximum Ratings

(Above which useful life may be impaired. For user guidelines, not tested.)

Maximum Supply Voltage, VDD, VDDO.....	4.6V
Inputs, V _I	-0.5V to VDD +0.5V
Output, V _O	-0.5V to VDDO +0.5V
Storage Temperature	-65°C to 150°C
ESD Protection (HBM).....	2000V

Note:

Stresses beyond those listed under Absolute Maximum Ratings may cause permanent damage to the device. These ratings are stress specifications only. Functional operation of product at these conditions or any conditions beyond those listed in the DC Characteristics or AC Characteristics is not implied. Exposure to absolute maximum rating conditions for extended periods may affect product reliability.

Power Supply DC Characteristics

T_A = -40°C to 85°C

Symbol	Parameter	Conditions	Min.	Typ.	Max.	Units
VDD	Core Supply Voltage	3.3V Operation	3.135	3.3	3.465	V
		2.5V Operation	2.375	2.5	2.625	
VDDO	Output Power Supply Voltage	3.3V Supply	3.135	3.3	3.465	V
		2.5V Supply	2.375	2.5	2.625	
IDD	Power Supply Current				5	mA
IDDO	Output Supply Current	Unloaded, 25MHz			6.5	mA

Note: Parameters measured up to f_{max} unless otherwise noted.

LVC MOS/LVTTL DC Characteristics

T_A = -40°C to 85°C

Symbol	Parameter	Conditions	Min.	Typ.	Max.	Units
V _{IH}	Input High Voltage	VDD = 3.3V	2		VDD+0.3	V
		VDD = 2.5V	1.7		VDD+0.3	
V _{IL}	Input Low Voltage	VDD = 3.3V	-0.3		0.8	V
		VDD = 2.5V	-0.3		0.8	
I _{IH}	Input High Current	VDD = V _{IN} = 3.465V			100	μA
		VDD = V _{IN} = 2.625V			80	
I _{IL}	Input Low Current	VDD = 3.465V, V _{IN} = 0V	-5			μA
		VDD = 2.625V, V _{IN} = 0V	-5			
V _{OH}	Output High Voltage	VDDO = 3.3V I _{OH} = -100μA	2.9			V
		VDDO = 2.5V I _{OH} = -100μA	2.2			V
V _{OL}	Output Low Voltage	VDDO = 3.3V I _{OL} = 100μA			0.2	V
		VDDO = 2.5V I _{OL} = 100μA			0.2	V

AC Characteristics

VDD = 3.3V ± 5%, T_A = -40°C to 85°C

Symbol	Parameter	Conditions	Min.	Typ.	Max.	Units
f _{MAX}	Output Frequency	VDDO = 3.3V	4		250	MHz
		VDDO = 2.5V	4		250	
t _{pLH}	Propagation Delay, Low-to-High ⁽¹⁾	VDDO = 3.3V, f ≤ 250MHz	1.4		2.2	ns
		VDDO = 2.5V, f ≤ 250MHz	1.5		3.0	
tsk(o)	Output Skew ⁽²⁾			25	80	ps
tsk(pp)	Part-to-Part Skew ⁽³⁾			250	800	ps
t _R	Output Rise Time ⁽⁴⁾	VDDO = 3.3V	100	300	400	ps
		VDDO = 2.5V	100	350	500	
t _F	Output Fall Time ⁽⁴⁾	VDDO = 3.3V	100	300	400	ps
		VDDO = 2.5V	100	350	500	
odc	Output Duty Cycle ⁽⁵⁾	f ≤ 133MHz	48		52	%
		133MHz < f ≤ 200MHz	47		53	%
		200MHz < f ≤ 250MHz	47		53	%
t _{jit}	Additive RMS Jitter	156.25MHz (@12kHz to 20MHz)		0.1		ps
		125MHz (@12kHz to 20MHz)		0.07		ps

Note:

Parameters measured at f_{MAX} unless otherwise noted.

1. Measured from VDD / 2 of the input to VDDO / 2 of the output.
2. Defined as skew between outputs at the same supply voltage and with equal load conditions. Measured at VDDO / 2.
3. Defined as skew between outputs on different devices operating at the same supply voltages and with equal load conditions. Using the same type of inputs on each device, the outputs are measured at VDDO / 2.
4. Defined from 20% to 80%
5. Measured at VDDO / 2

AC Characteristics

VDD = 2.5V ± 5%, T_A = -40°C to 85°C

Symbol	Parameter	Conditions	Min.	Typ.	Max.	Units
f _{MAX}	Output Frequency	VDDO = 2.5V	4		250	MHz
t _{PLH}	Propagation Delay, Low-to-High ⁽¹⁾	VDDO = 2.5V, f ≤ 250MHz	1.5		2.8	ns
tsk(o)	Output Skew ⁽²⁾			25	75	ps
tsk(pp)	Part-to-Part Skew ⁽³⁾			250	800	ps
t _R	Output Rise Time ⁽⁴⁾	VDDO = 2.5V	100	350	500	ps
t _F	Output Fall Time ⁽⁴⁾	VDDO = 2.5V	100	350	500	ps
odc	Output Duty Cycle ⁽⁵⁾	f ≤ 133MHz	48		52	%
		133MHz < f ≤ 200MHz	47		53	%
		200MHz < f ≤ 250MHz	42		58	%
t _{jit}	Additive RMS Jitter	156.25MHz (@12kHz to 20MHz)		0.1		ps
		125MHz (@12kHz to 20MHz)		0.07		ps

Note:

Parameters measured at f_{MAX} unless otherwise noted.

1. Measured from VDD / 2 of the input to VDDO / 2 of the output.
2. Defined as skew between outputs at the same supply voltage and with equal load conditions. Measured at VDDO / 2.
3. Defined as skew between outputs on different devices operating at the same supply voltages and with equal load conditions. Using the same type of inputs on each device, the outputs are measured at VDDO / 2.
4. Defined from 20% to 80%
5. Measured at VDDO / 2

AC Test Circuit Load

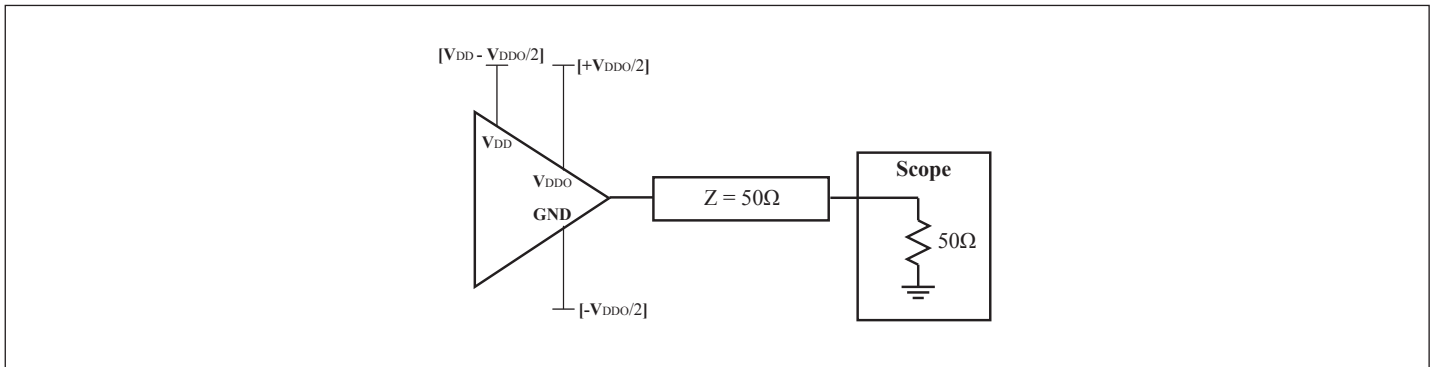

PI6C49X0202

Part Marking

PI6C49X
0202WIE
YYYWWX^X
○

Y: Die Rev
YY: Year
WW: Workweek
1st X: Assembly Code
2nd X: Fab Code

Packaging Mechanical

8-SOIC (W)

SYMBOLS	MIN.	NOM.	MAX.
A	—	—	1.75
A1	0.10	—	0.25
A2	1.25	—	—
b	0.31	—	0.51
c	0.10	—	0.25
D	4.80	4.90	5.00
E	5.80	6.00	6.20
E1	3.80	3.90	4.00
e	1.27 BSC		
L	0.40	—	1.27
h	0.25	—	0.50
θ°	0	—	8

NOTE :
 1. ALL DIMENSIONS ARE IN mm. ANGLES IN DEGREES
 2. DIMENSIONS EXCLUDE BURRS, MOLD FLASH OR PROTRUSIONS
 3. REFER JEDEC MS-012
 4. RECOMMENDED LAND PATTERN IS FOR REFERENCE ONLY.

20-1273

DIODES **PERICOM** ENABLING SERIAL CONNECTIVITY

DESCRIPTION: 8-Pin, 150mil-Wide, SOIC

PACKAGE CODE: W (W8)

DOCUMENT CONTROL #: PD-1001

DATE: 06/02/20

REVISION: H

For latest package info.

please check: <http://www.diodes.com/design/support/packaging/pericom-packaging/packaging-mechanicals-and-thermal-characteristics/>

Ordering Information

Ordering Code	Package Code	Package Description
PI6C49X0202WIEX	W	8-pin, 150mil-Wide (SOIC)

Notes:

1. No purposely added lead. Fully EU Directive 2002/95/EC (RoHS), 2011/65/EU (RoHS 2) & 2015/863/EU (RoHS 3) compliant.
2. See <https://www.diodes.com/quality/lead-free/> for more information about Diodes Incorporated's definitions of Halogen- and Antimony-free, "Green" and Lead-free.
3. Halogen- and Antimony-free "Green" products are defined as those which contain <900ppm bromine, <900ppm chlorine (<1500ppm total Br + Cl) and <1000ppm antimony compounds.
4. I = Industrial
5. E = Pb-free and Green
6. X suffix = Tape/Reel

IMPORTANT NOTICE

1. DIODES INCORPORATED (Diodes) AND ITS SUBSIDIARIES MAKE NO WARRANTY OF ANY KIND, EXPRESS OR IMPLIED, WITH REGARDS TO ANY INFORMATION CONTAINED IN THIS DOCUMENT, INCLUDING, BUT NOT LIMITED TO, THE IMPLIED WARRANTIES OF MERCHANTABILITY, FITNESS FOR A PARTICULAR PURPOSE OR NON-INFRINGEMENT OF THIRD PARTY INTELLECTUAL PROPERTY RIGHTS (AND THEIR EQUIVALENTS UNDER THE LAWS OF ANY JURISDICTION).

2. The Information contained herein is for informational purpose only and is provided only to illustrate the operation of Diodes' products described herein and application examples. Diodes does not assume any liability arising out of the application or use of this document or any product described herein. This document is intended for skilled and technically trained engineering customers and users who design with Diodes' products. Diodes' products may be used to facilitate safety-related applications; however, in all instances customers and users are responsible for (a) selecting the appropriate Diodes products for their applications, (b) evaluating the suitability of Diodes' products for their intended applications, (c) ensuring their applications, which incorporate Diodes' products, comply the applicable legal and regulatory requirements as well as safety and functional-safety related standards, and (d) ensuring they design with appropriate safeguards (including testing, validation, quality control techniques, redundancy, malfunction prevention, and appropriate treatment for aging degradation) to minimize the risks associated with their applications.

3. Diodes assumes no liability for any application-related information, support, assistance or feedback that may be provided by Diodes from time to time. Any customer or user of this document or products described herein will assume all risks and liabilities associated with such use, and will hold Diodes and all companies whose products are represented herein or on Diodes' websites, harmless against all damages and liabilities.

4. Products described herein may be covered by one or more United States, international or foreign patents and pending patent applications. Product names and markings noted herein may also be covered by one or more United States, international or foreign trademarks and trademark applications. Diodes does not convey any license under any of its intellectual property rights or the rights of any third parties (including third parties whose products and services may be described in this document or on Diodes' website) under this document.

5. Diodes' products are provided subject to Diodes' Standard Terms and Conditions of Sale (<https://www.diodes.com/about/company/terms-and-conditions/terms-and-conditions-of-sales/>) or other applicable terms. This document does not alter or expand the applicable warranties provided by Diodes. Diodes does not warrant or accept any liability whatsoever in respect of any products purchased through unauthorized sales channel.

6. Diodes' products and technology may not be used for or incorporated into any products or systems whose manufacture, use or sale is prohibited under any applicable laws and regulations. Should customers or users use Diodes' products in contravention of any applicable laws or regulations, or for any unintended or unauthorized application, customers and users will (a) be solely responsible for any damages, losses or penalties arising in connection therewith or as a result thereof, and (b) indemnify and hold Diodes and its representatives and agents harmless against any and all claims, damages, expenses, and attorney fees arising out of, directly or indirectly, any claim relating to any noncompliance with the applicable laws and regulations, as well as any unintended or unauthorized application.

7. While efforts have been made to ensure the information contained in this document is accurate, complete and current, it may contain technical inaccuracies, omissions and typographical errors. Diodes does not warrant that information contained in this document is error-free and Diodes is under no obligation to update or otherwise correct this information. Notwithstanding the foregoing, Diodes reserves the right to make modifications, enhancements, improvements, corrections or other changes without further notice to this document and any product described herein. This document is written in English but may be translated into multiple languages for reference. Only the English version of this document is the final and determinative format released by Diodes.

8. Any unauthorized copying, modification, distribution, transmission, display or other use of this document (or any portion hereof) is prohibited. Diodes assumes no responsibility for any losses incurred by the customers or users or any third parties arising from any such unauthorized use.

9. This Notice may be periodically updated with the most recent version available at <https://www.diodes.com/about/company/terms-and-conditions/important-notice>

The Diodes logo is a registered trademark of Diodes Incorporated in the United States and other countries.

All other trademarks are the property of their respective owners.

© 2023 Diodes Incorporated. All Rights Reserved.

www.diodes.com

Looking for pricing, stock, or lifecycle information?

Click below to explore more details on WIN SOURCE:

 [View PI6C49X0202WIE on WIN SOURCE](#)

 [Diodes Incorporated](#) Information

Optimize Your Supply Chain with WIN SOURCE Solutions

-  Global Sourcing Solution
-  Obsolete Management
-  Cost Control Management
-  Shortage Management
-  Alternative Solution
-  Excess Inventory Management