



**THE DATASHEET OF
PI4ULS5V106ZHDEX**



6-Bit Bi-directional Level Shifter for Open-Drain and Push-Pull Application

Features

- Provides Bidirectional Voltage Translation With No Direction Pin
- Supports Up to 100 MHz Up Translation and Greater Than 100 MHz Down Translation at $\leq 30\text{pF}$ Cap Load and Up To 40 MHz Up/Down Translation at 50 pF Cap Load
- Supports Hot Insertion
- Allow Bidirectional Voltage Level Translation Between
 - 0.95 V \leftrightarrow 1.8/2.5/3.3/5 V
 - 1.2 V \leftrightarrow 1.8/2.5/3.3/5 V
 - 1.8 V \leftrightarrow 2.5/3.3/5 V
 - 2.5 V \leftrightarrow 3.3/5 V
 - 3.3 V \leftrightarrow 5 V
- Low Standby Current
- 5 V Tolerance I/O Port to Support TTL
- Low Ron Provides Less Signal Distortion
- High-Impedance I/O pins For EN = Low
- Flow-Through Pin out for Ease PCB Trace Routing
- ESD protection (8KV HBM and 1KV CDM)
- Latch-Up Performance Exceeds 100 mA Per JESD 17
- -40°C to 125°C Operating Temperature Range
- Package: UQFN-16

Description

The PI4ULS5V106 supports up to 100 MHz up translation and greater than 100 MHz down translation at $\leq 30\text{pF}$ cap load and up to 40 MHz up/down translation at 50pF cap load which allows the LSF family to support more consumer or telecom interfaces (MDIO or SDIO). It has bidirectional voltage translation without the need for DIR pin which minimizes system effort (for PMBus, I2C, or SMBus).

The PI4ULS5V106 supports 5 V tolerance on IO port which makes it compatible with TTL levels in industrial and telecom applications. It is able to set up different voltage translation levels on each channel which makes it very flexible.

Pin Configuration

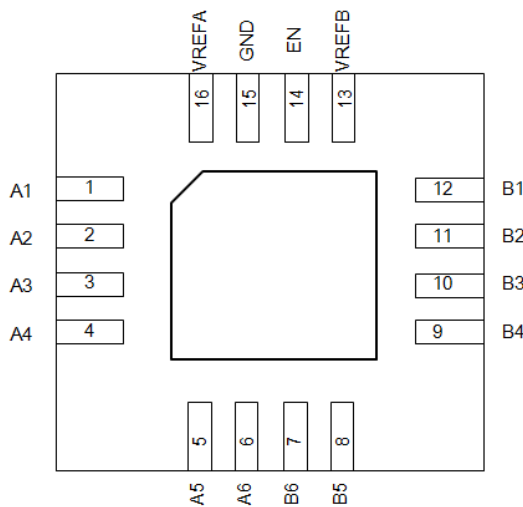

Pin Description

Pin Name	Pin No.	Description
GND	15	Ground.
VREFA	16	Reference supply voltage A
An	1-6	Data port A
Bn	7-12	Data port B
VREFB	13	Reference supply voltage B
EN	14	Enable. Connect to VREFB and pull-up through a 200kΩ resistor

Block Diagram

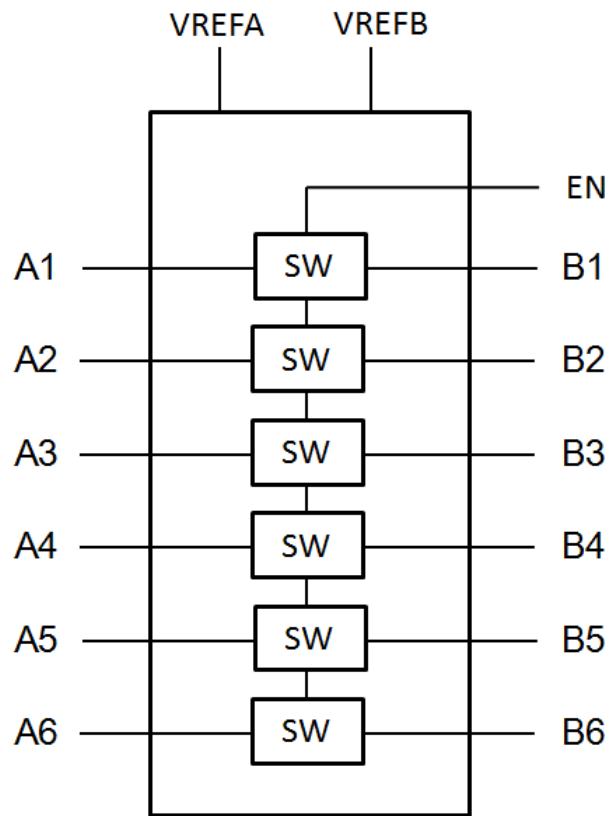

Figure 1: Block Diagram

Maximum Ratings

Storage Temperature.....	-65°C to +150°C
T _j , Junction temperature.....	125°C
Reference Voltage.....	-0.5V to +7.0V
I/O Input Voltage.....	-0.5V to +7.0V
channel current (DC).....	128mA
Input clamping Current.....	-50Ma

Note:

Stresses greater than those listed under MAXIMUM RATINGS may cause permanent damage to the device. This is a stress rating only and functional operation of the device at these or any other conditions above those indicated in the operational sections of this specification is not implied. Exposure to absolute maximum rating conditions for extended periods may affect reliability.

Recommended operation conditions

Symbol	Parameter	Min.	Typ.	Max.	Unit
V _{I/O}	Voltage on an input/output pin	0	-	5	V
VREFA	Reference voltage	0	-	5	V
VREFB	Reference bias voltage	0	-	5	V
VEN	Input voltage on pin EN	0	-	5	V
I _(pass)	Pass switch current	-	-	64	mA
T _A	Ambient temperature	-40	-	85	°C

DC Electrical Characteristics

(T_A = -40°C to 85°C, unless otherwise noted. Typical values are at 3.3V V_{dd} and +25°C.)

Parameter	Description	Test Conditions ⁽¹⁾	Min	Typ. ⁽²⁾	Max	Unit
Input and output SDAB and SCLB						
V _{IK}	input clamping voltage	I _I = -18mA; VEN = 0 V	-	-	-1.2	V
I _{IH}	HIGH-level input current	V _I = 5 V; VEN = 0 V	-	-	5	μA
ICC	Supply Current	VREFB = VEN = 5.5 V, VREFA = 4.5 V or 1 V, IO = 0, VI = VCC or GND	-	1	-	μA
C _{i(refA/refB/EN)}	input capacitance on pin VREFA, VREFB, EN	V _I = 3 V or 0 V	-	11	-	pF
C _{io(off)}	off-state input/output capacitance	V _O = 3 V or 0 V; VEN = 0 V	-	4	-	pF
C _{io(on)}	on-state input/output capacitance	V _O = 3 V or 0 V; VEN = 3 V	-	10.5	-	pF
Ron	ON-state resistance	V _I = 0V; I _O = 64mA; VREFB, VEN connect to 5 V through 200k Ω	VREFA = 3.3 V;	8	-	Ω
			VREFA = 1.8 V;	9	-	Ω
			VREFA = 1.0 V;	10	-	Ω
		V _I = 0V; I _O = 32mA VREFB, VEN connect to 5 V through 200k Ω	VREFA = 1.8 V;	10	-	Ω
			VREFA = 2.5 V;	15	-	Ω
		V _I = 1.8V; I _O = 15mA VREFB, VEN connect to 5V through 200k Ω	VREFA = 3.3 V;	9	-	Ω
		V _I = 1.0V; I _O = 10mA VREFB, VEN connect to 3.3V through 200k Ω	VREFA = 1.8 V;	18	-	Ω
		V _I = 0V; I _O = 10mA VREFB, VEN connect to 3.3V through 200k Ω	VREFA = 1.0 V;	20	-	Ω
V _I = 0V; I _O = 10mA VREFB, VEN connect to 1.8V through 200k Ω	VREFA = 1.0 V;	30	-	Ω		

Notes:

- 1) All typical values are at T_A = 25 °C.
- 2) Measured by the voltage drop between the A and B pins at the indicated current through the switch. ON-state resistance is determined by the lowest voltage of the two terminals.

Dynamic characteristics

$T_A = -40^{\circ}\text{C}$ to $+85^{\circ}\text{C}$; unless otherwise specified. Values guaranteed by design.

Symbol	Parameter	Conditions	$C_L = 50 \text{ pF}$		$C_L = 30 \text{ pF}$		$C_L = 15 \text{ pF}$		Unit
			Typ	Max	Typ	Max	Typ	Max	
Dynamic characteristics (translating down)									
$V_{EN} = 3.3 \text{ V}; V_{IH} = 3.3 \text{ V}; V_{IL} = 0 \text{ V}; V_M = 1.15 \text{ V}$									
t_{PLH}	LOW-to-HIGH propagation delay	From A \rightarrow B or B \rightarrow A	1.9		1.4		0.78		ns
t_{PHL}	HIGH-to-LOW propagation delay		2		1.5		0.85		ns
$V_{EN} = 2.5 \text{ V}; V_{IH} = 2.5 \text{ V}; V_{IL} = 0 \text{ V}; V_M = 0.75 \text{ V}$									
t_{PLH}	LOW-to-HIGH propagation delay	From A \rightarrow B or B \rightarrow A	2		1.45		0.8		ns
t_{PHL}	HIGH-to-LOW propagation delay		2.1		1.55		0.9		ns
Dynamic characteristics (translating up)									
$V_{EN} = 3.3 \text{ V}; V_{IH} = 2.3 \text{ V}; V_{IL} = 0 \text{ V}; V_T = 3.3 \text{ V}; V_M = 1.15 \text{ V}; R_L = 300 \Omega$									
t_{PLH}	LOW-to-HIGH propagation delay		2.1		1.55		0.9		ns
t_{PHL}	HIGH-to-LOW propagation delay		2.2		1.65		1		ns
$V_{EN} = 2.5 \text{ V}; V_{IH} = 1.5 \text{ V}; V_{IL} = 0 \text{ V}; V_T = 2.5 \text{ V}; V_M = 0.75 \text{ V}; R_L = 300 \Omega$									
t_{PLH}	LOW-to-HIGH propagation delay		1.8		1.35		0.8		ns
t_{PHL}	HIGH-to-LOW propagation delay		1.9		1.45		0.9		ns

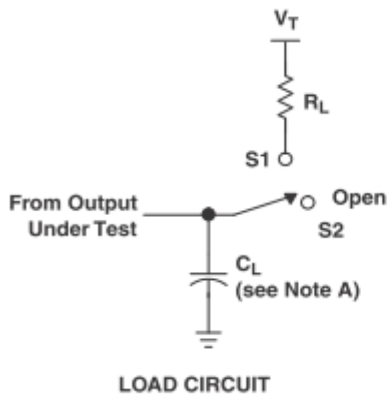

USAGE	SWITCH
Translating up	S1
Translating down	S2

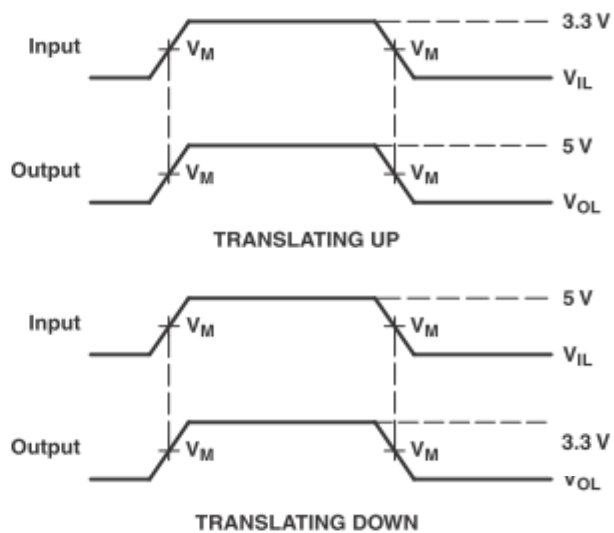

- NOTES: A. C_L includes probe and jig capacitance.
 B. All input pulses are supplied by generators having the following characteristics: PRR $\leq 10 \text{ MHz}$, $Z_O = 50 \Omega$, $t_r \leq 2 \text{ ns}$, $t_f \leq 2 \text{ ns}$.
 C. The outputs are measured one at a time, with one transition per measurement.

Figure 2: Test Circuit

The master output driver can be totem pole or open-drain (pull-up resistors may be required) and the slave device output can be totem pole or open-drain (pull-up resistors are required to pull the Bn outputs to VPUB. However, if either output is totem-pole, data must be unidirectional or the outputs must be 3-stateable and be controlled by some direction-control mechanism to prevent HIGH-to-LOW contentions in either direction. If both outputs are open-drain, no direction control is needed.

When VREFB is connected through a 200k ohm resistor to a 3.3 V to 5.5 V power supply, and VREFA is set between 1.0 V and VPUB-1V, the output of each An has a maximum output voltage equal to VREFA, and the output of each Bn has a maximum output voltage equal to VPUB.

Pull-up resistors and minimum values

Sizing the pull-up resistor on an open-drain bus is specific to the individual application and is dependent on the following driver characteristics:

- The driver sink current
- The V_{OL} of driver
- The V_{OL} of the PI6ULS5V108
- The V_{IL} of the driver
- Frequency of operation

The following tables can be used to estimate the pull-up resistor value in different use cases so that the minimum resistance for the pull-up resistor can be found.

Tables in bellow contain suggested minimum values of pull-up resistors for the PI6UILS5V9306 with typical voltage translation levels and drive currents.

The calculated values assume that both drive currents are the same.

$V_{OL} = V_{IL} = 0.1 * V_{CC}$ and accounts for a 5 % VCC tolerance of the supplies, 1 % resistor values. It should be noted that the resistor chosen in the final application should be equal to or larger than the values shown in the table to ensure that the pass voltage is less than 10 % of the VCC voltage, and the external driver should be able to sink the total current from both pull-up resistors.

Pull-up resistor minimum values, 3 mA driver sink current for PI6ULS5V108

A Side	B side				
	1.5V	1.8V	2.5V	3.3V	5.0V
0.9V	$R_{RPUA} = 859\Omega$ $R_{RPUB} = 859\Omega$	$R_{RPUA} = 970\Omega$ $R_{RPUB} = 970\Omega$	$R_{RPUA} = \text{none}$ $R_{RPUB} = 896\Omega$ Or both 1.23k Ω	$R_{RPUA} = \text{none}$ $R_{RPUB} = 1.19k\Omega$ Or both 1.53k Ω	$R_{RPUA} = \text{none}$ $R_{RPUB} = 1.82k\Omega$ Or both 2.16k Ω
1.2V		$R_{RPUA} = 1.07k\Omega$ $R_{RPUB} = 1.07k\Omega$	$R_{RPUA} = \text{none}$ $R_{RPUB} = 886\Omega$ Or both 1.33k Ω	$R_{RPUA} = \text{none}$ $R_{RPUB} = 1.18k\Omega$ Or both 1.63k Ω	$R_{RPUA} = \text{none}$ $R_{RPUB} = 1.81k\Omega$ Or both 2.26k Ω
1.5V			$R_{RPUA} = \text{none}$ $R_{RPUB} = 875\Omega$ Or both 1.43k Ω	$R_{RPUA} = \text{none}$ $R_{RPUB} = 1.17k\Omega$ Or both 1.73k Ω	$R_{RPUA} = \text{none}$ $R_{RPUB} = 1.8k\Omega$ Or both 2.36k Ω
1.8V			$R_{RPUA} = 1.53k\Omega$ $R_{RPUB} = 1.53k\Omega$	$R_{RPUA} = \text{none}$ $R_{RPUB} = 1.16k\Omega$ Or both 1.82k Ω	$R_{RPUA} = \text{none}$ $R_{RPUB} = 1.79k\Omega$ Or both 2.46k Ω
2.5V				$R_{RPUA} = 2.06k\Omega$ $R_{RPUB} = 2.06k\Omega$	$R_{RPUA} = \text{none}$ $R_{RPUB} = 1.77k\Omega$ Or both 2.69k Ω
3.3V					$R_{RPUA} = \text{none}$ $R_{RPUB} = 1.74k\Omega$ Or both 2.96k Ω

Pull-up resistor minimum values, 10 mA driver sink current for PI6ULS5V108

A Side	B side				
	1.5V	1.8V	2.5V	3.3V	5.0V
0.9V	R _{RPUB} = 258Ω R _{RPUA} = 258Ω	R _{RPUB} = 291Ω R _{RPUA} = 291Ω	R _{RPUB} = 269Ω R _{RPUA} = none Or both 369Ω	R _{RPUB} = 358Ω R _{RPUA} = none Or both 458Ω	R _{RPUB} = 546Ω R _{RPUA} = none Or both 646Ω
1.2V		R _{RPUB} = 321Ω R _{RPUA} = 321Ω	R _{RPUB} = 266Ω R _{RPUA} = none Or both 399Ω	R _{RPUB} = 355Ω R _{RPUA} = none Or both 488Ω	R _{RPUB} = 543Ω R _{RPUA} = none Or both 677Ω
1.5V			R _{RPUB} = 263Ω R _{RPUA} = none Or both 429Ω	R _{RPUB} = 352Ω R _{RPUA} = none Or both 518Ω	R _{RPUB} = 540Ω R _{RPUA} = none Or both 707Ω
1.8V			R _{RPUB} = 460Ω R _{RPUA} = 460Ω	R _{RPUB} = 348Ω R _{RPUA} = none Or both 548Ω	R _{RPUB} = 537Ω R _{RPUA} = none Or both 737Ω
2.5V				R _{RPUB} = 619Ω R _{RPUA} = 619Ω	R _{RPUB} = 521Ω R _{RPUA} = none Or both 808Ω
3.3V					R _{RPUB} = 522Ω R _{RPUA} = none Or both 889Ω

Pull-up resistor minimum values, 15 mA driver sink current for PI6ULS5V108

A Side	B side				
	1.5V	1.8V	2.5V	3.3V	5.0V
0.9V	R _{RPUB} = 172Ω R _{RPUA} = 172Ω	R _{RPUB} = 194Ω R _{RPUA} = 194Ω	R _{RPUB} = 179Ω R _{RPUA} = none Or both 246Ω	R _{RPUB} = 238Ω R _{RPUA} = none Or both 305Ω	R _{RPUB} = 364Ω R _{RPUA} = none Or both 431Ω
1.2V		R _{RPUB} = 214Ω R _{RPUA} = 214Ω	R _{RPUB} = 177Ω R _{RPUA} = none Or both 266Ω	R _{RPUB} = 236Ω R _{RPUA} = none Or both 325Ω	R _{RPUB} = 362Ω R _{RPUA} = none Or both 451Ω
1.5V			R _{RPUB} = 175Ω R _{RPUA} = none Or both 286Ω	R _{RPUB} = 234Ω R _{RPUA} = none Or both 345Ω	R _{RPUB} = 360Ω R _{RPUA} = none Or both 471Ω
1.8V			R _{RPUB} = 306Ω R _{RPUA} = 306Ω	R _{RPUB} = 232Ω R _{RPUA} = none Or both 366Ω	R _{RPUB} = 358Ω R _{RPUA} = none Or both 492Ω
2.5V				R _{RPUB} = 413Ω R _{RPUA} = 413Ω	R _{RPUB} = 354Ω R _{RPUA} = none Or both 539Ω
3.3V					R _{RPUB} = 348Ω R _{RPUA} = none Or both 593Ω

Max Frequency Application

The maximum frequency is limited by the minimum pulse width LOW and HIGH as well as rise time and fall time.

$$f(\text{max}) = \frac{1}{t_{\text{LOW}}(\text{min}) + t_{\text{HIGH}}(\text{min}) + t_{\text{r}}(\text{actual}) + t_{\text{f}}(\text{actual})}$$

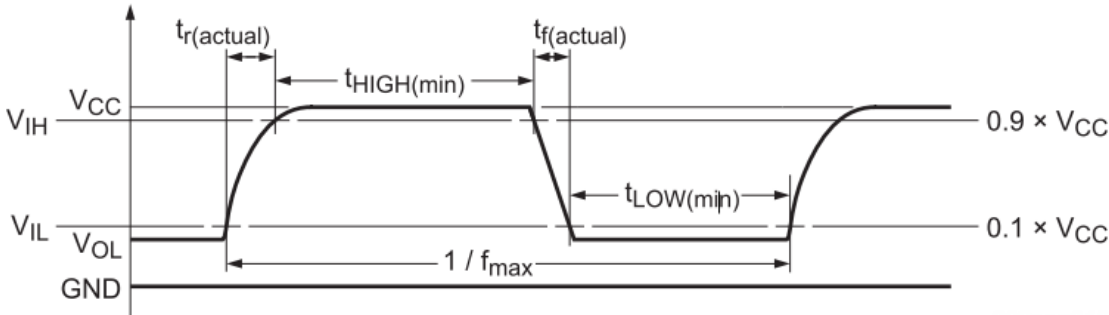

The rise and fall times are dependent upon translation voltages, the drive strength, the total node capacitance (CL) and the pull-up resistors (RPU) that are present on the bus. The node capacitance is the addition of the PCB trace capacitance and the device capacitance that exists on the bus.

Because of the dependency of the external components, PCB layout and the different device operating states the calculation of rise and fall times is complex and has several inflection points along the curve.

The main component of the rise and fall times is the RC time constant of the bus line when the device is in its two primary operating states: when device is in the ON state and it is low-impedance, the other is when the device is OFF isolating the A-side from the B-side.

There are some basic guidelines to follow that will help maximize the performance of the device:

- Keep trace length to a minimum by placing the PI6ULS5V108 close to the processor.
- The signal round trip time on trace should be shorter than the rise or fall time of signal to reduce reflections.
- The faster the edge of the signal, the higher the chance for ringing.
- The higher drive strength controlled by the pull-up resistor (up to 15 mA), the higher the frequency the device can use.

The system designer must design the pull-up resistor value based on external current drive strength and limit the node capacitance (minimize the wire, stub, connector and trace length) to get the desired operation frequency result.

Part Marking

ZHD Package



Y: Date Code (Year)

W: Date Code (Workweek)

1st X: Assembly Site Code

2nd X: Wafer Fab Site Code

Bar above fab code means Cu wire

Packaging Mechanical
16-UQFN (ZHD)

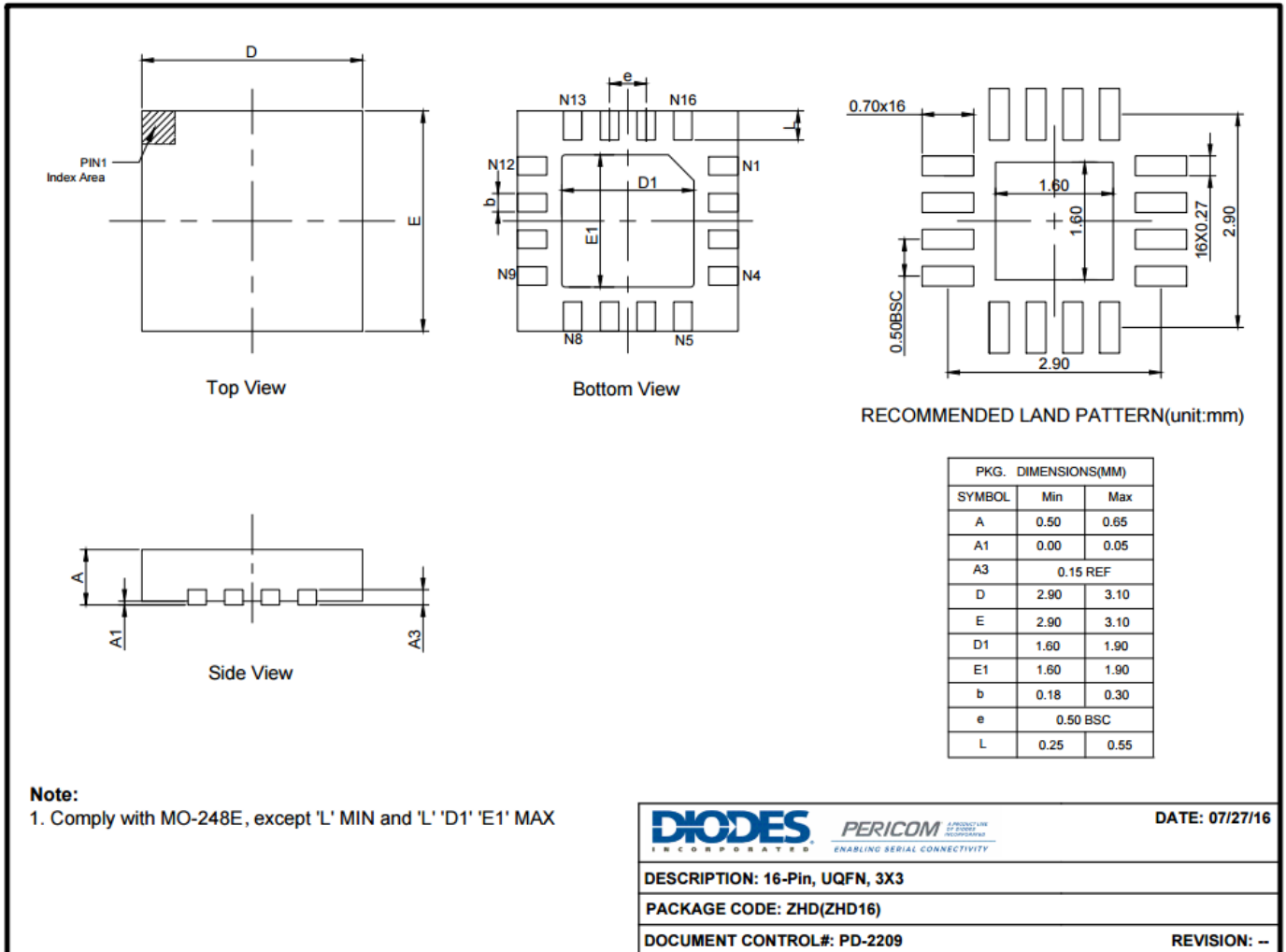

For latest package info.

please check: <http://www.diodes.com/design/support/packaging/pericom-packaging/packaging-mechanicals-and-thermal-characteristics/>

Ordering Information

Part No.	Package Code	Package
PI4ULS5V106ZHDEX	ZHD	16-Pin, 3x3 (UQFN)

- Notes:**
- No purposely added lead. Fully EU Directive 2002/95/EC (RoHS), 2011/65/EU (RoHS 2) & 2015/863/EU (RoHS 3).compliant.
 - See <http://www.diodes.com/quality/lead-free/> for more information about Diodes Incorporated's definitions of Halogen- and Antimony-free, "Green" and Lead-free.
 - Thermal characteristics can be found on the company web site at www.diodes.com/design/support/packaging/
 - E = Pb-free and Green
 - X suffix = Tape/Reel

IMPORTANT NOTICE

DIODES INCORPORATED MAKES NO WARRANTY OF ANY KIND, EXPRESS OR IMPLIED, WITH REGARDS TO THIS DOCUMENT, INCLUDING, BUT NOT LIMITED TO, THE IMPLIED WARRANTIES OF MERCHANTABILITY AND FITNESS FOR A PARTICULAR PURPOSE (AND THEIR EQUIVALENTS UNDER THE LAWS OF ANY JURISDICTION).

Diodes Incorporated and its subsidiaries reserve the right to make modifications, enhancements, improvements, corrections or other changes without further notice to this document and any product described herein. Diodes Incorporated does not assume any liability arising out of the application or use of this document or any product described herein; neither does Diodes Incorporated convey any license under its patent or trademark rights, nor the rights of others. Any Customer or user of this document or products described herein in such applications shall assume all risks of such use and will agree to hold Diodes Incorporated and all the companies whose products are represented on Diodes Incorporated website, harmless against all damages.

Diodes Incorporated does not warrant or accept any liability whatsoever in respect of any products purchased through unauthorized sales channel.

Should Customers purchase or use Diodes Incorporated products for any unintended or unauthorized application, Customers shall indemnify and hold Diodes Incorporated and its representatives harmless against all claims, damages, expenses, and attorney fees arising out of, directly or indirectly, any claim of personal injury or death associated with such unintended or unauthorized application.

Products described herein may be covered by one or more United States, international or foreign patents pending. Product names and markings noted herein may also be covered by one or more United States, international or foreign trademarks.

This document is written in English but may be translated into multiple languages for reference. Only the English version of this document is the final and determinative format released by Diodes Incorporated.

LIFE SUPPORT

Diodes Incorporated products are specifically not authorized for use as critical components in life support devices or systems without the express written approval of the Chief Executive Officer of Diodes Incorporated. As used herein:

A. Life support devices or systems are devices or systems which:

1. are intended to implant into the body, or
2. support or sustain life and whose failure to perform when properly used in accordance with instructions for use provided in the labeling can be reasonably expected to result in significant injury to the user.

B. A critical component is any component in a life support device or system whose failure to perform can be reasonably expected to cause the failure of the life support device or to affect its safety or effectiveness.

Customers represent that they have all necessary expertise in the safety and regulatory ramifications of their life support devices or systems, and acknowledge and agree that they are solely responsible for all legal, regulatory and safety-related requirements concerning their products and any use of Diodes Incorporated products in such safety-critical, life support devices or systems, notwithstanding any devices- or systems-related information or support that may be provided by Diodes Incorporated. Further, Customers must fully indemnify Diodes Incorporated and its representatives against any damages arising out of the use of Diodes Incorporated products in such safety-critical, life support devices or systems.

Copyright © 2016, Diodes Incorporated
www.diodes.com

Looking for pricing, stock, or lifecycle information?

Click below to explore more details on WIN SOURCE:

- ⊖ [View PI4ULS5V106ZHDEX on WIN SOURCE](#)
- ⊖ [Diodes Incorporated Information](#)

Optimize Your Supply Chain with WIN SOURCE Solutions

- ✓ Global Sourcing Solution
- ✓ Obsolete Management
- ✓ Cost Control Management
- ✓ Shortage Management
- ✓ Alternative Solution
- ✓ Excess Inventory Management