



**THE DATASHEET OF  
PI49FCT3805BQE**



**PI49FCT3805/PI49FCT3806**

**3.3V Fast CMOS Buffer/Clock Driver**

**Features**

- 3.3V version of PI49FCT805/806
- Extremely low output skew: 0.5ns
- Monitor output pin
- Clock busing with 3-state control
- TTL input and CMOS output compatible
- Industrial operation at -40°C to 85°C
- Extremely low static power (1mW, typ.)
- Hysteresis on all inputs
- Totally Lead-Free & Fully RoHS Compliant (Notes 1 & 2)
- Halogen and Antimony Free. "Green" Device (Note 3)
- For automotive applications requiring specific change control (i.e. parts qualified to AEC-Q100/101/200, PPAP capable, and manufactured in IATF 16949 certified facilities), please [contact us](https://www.diodes.com/quality/product-definitions/) or your local Diodes representative.  
<https://www.diodes.com/quality/product-definitions/>
- Packaging (Pb-free & Green available):
  - 20-pin 150-mil wide QSOP (Q)
  - 20-pin 209-mil wide SSOP (H)

**Description**

Diodes' PI49FCT3805 is a 3.3V non-inverting clock driver and the PI49FCT3806 is a 3.3V inverting clock driver designed with two independent groups of buffers. These buffers have 3-state Output Enable inputs (active LOW) with a 1-in, 5-out configuration per group. Each clock driver consist of two banks of drivers, driving five outputs each from a standard TTL compatible CMOS input.

**PI49FCT3805 Block Diagram**

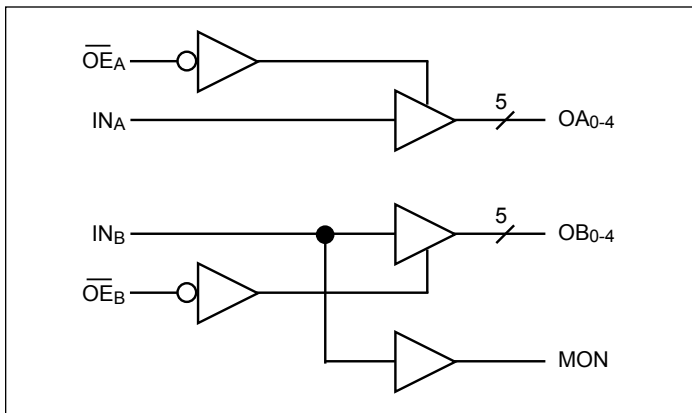

**PI49FCT3806 Block Diagram**

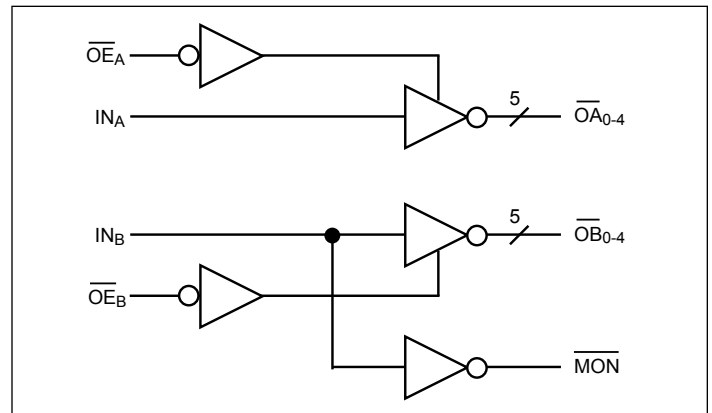

**Notes:**

1. No purposely added lead. Fully EU Directive 2002/95/EC (RoHS), 2011/65/EU (RoHS 2) & 2015/863/EU (RoHS 3) compliant.
2. See <https://www.diodes.com/quality/lead-free/> for more information about Diodes Incorporated's definitions of Halogen- and Antimony-free, "Green" and Lead-free.
3. Halogen- and Antimony-free "Green" products are defined as those which contain <900ppm bromine, <900ppm chlorine (<1500ppm total Br + Cl) and <1000ppm antimony compounds.

**PI49FCT3805/PI49FCT3806**

**PI49FCT3805 Pin Configuration**

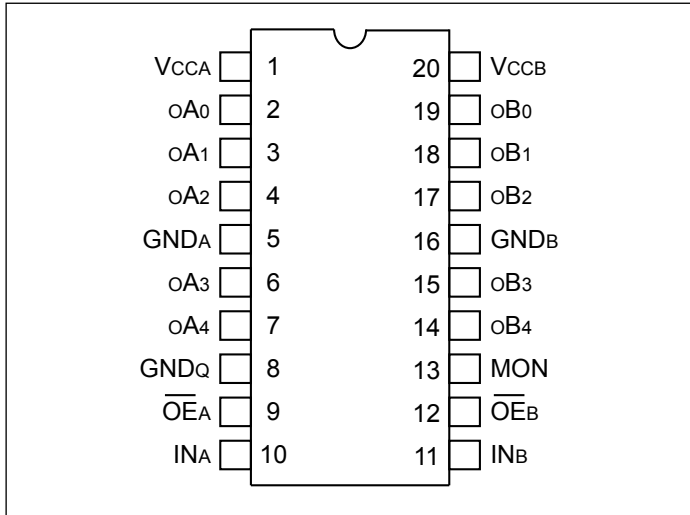

**PI49FCT3806 Pin Configuration**

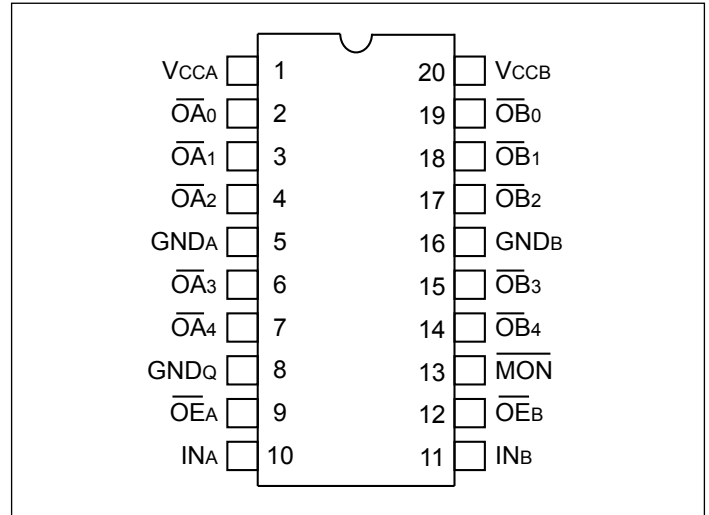

**Pin Description**

Pin Name	Description
$\overline{OE}_A, \overline{OE}_B$	3-State Output Enable Inputs (Active LOW)
$IN_A, IN_B$	Clock Inputs
$oA_N, oB_N$	Clock Outputs
MON	Monitor Output
GND	Ground
VCC	Power

**PI49FCT3805 Truth Table<sup>(1)</sup>**

Inputs		Outputs	
$\overline{OE}_A, \overline{OE}_B$	$IN_A, IN_B$	$oA_N, oB_N$	MON
L	L	L	L
L	H	H	H
H	L	Z	L
H	H	Z	H

**Note:**

1. H = High Voltage Level, L = Low Voltage Level  
Z = High Impedance

**PI49FCT3806 Truth Table<sup>(1)</sup>**

Inputs		Outputs	
$\overline{OE}_A, \overline{OE}_B$	$IN_A, IN_B$	$\overline{oA}_N, \overline{oB}_N$	$\overline{MON}$
L	L	H	H
L	H	L	L
H	L	Z	H
H	H	Z	L

**Note:**

1. H = High Voltage Level, L = Low Voltage Level, Z = High Impedance

## Maximum Ratings

(Above which the useful life may be impaired. For user guidelines, not tested.)

Storage Temperature.....	-65°C to +150°C
Ambient Temperature with Power Applied.....	-40°C to +85°C
Supply Voltage to Ground Potential (Inputs & V <sub>CC</sub> Only)....	-0.5V to +7.0V
Supply Voltage to Ground Potential (Outputs & I/O Only).....	-0.5V to +7.0V
DC Input Voltage .....	-0.5V to +7.0V
DC Output Current .....	120 mA
Power Dissipation .....	0.5W

**Note:**

Stresses greater than those listed under MAXIMUM RATINGS may cause permanent damage to the device. This is a stress rating only and functional operation of the device at these or any other conditions above those indicated in the operational sections of this specification is not implied. Exposure to absolute maximum rating conditions for extended periods may affect reliability.

## DC Electrical Characteristics (T<sub>A</sub> = -40°C to +85°C, V<sub>CC</sub> = 3.3V ±0.3V)

Symbol	Parameter	Test Condition <sup>(1)</sup>		Min.	Typ.	Max.	Units
V <sub>OH</sub>	Output High Voltage V <sub>CC</sub> = 3.0V, V <sub>IN</sub> = V <sub>IL</sub> or V <sub>IH</sub>	V <sub>CC</sub> = Min., V <sub>IN</sub> = V <sub>IH</sub> or V <sub>IL</sub>	I <sub>OH</sub> = -0.1mA I <sub>OH</sub> = -8mA	V <sub>CC</sub> - 0.2 2.4 (3)	- 3.0		V
V <sub>OL</sub>	Output Low Voltage V <sub>CC</sub> = 3.0V, V <sub>IN</sub> = V <sub>IL</sub> or V <sub>IH</sub>	V <sub>CC</sub> = Min., V <sub>IN</sub> = V <sub>IH</sub> or V <sub>IL</sub>	I <sub>OL</sub> = 0.1mA I <sub>OL</sub> = 16mA I <sub>OL</sub> = 24mA		- 0.2 0.3	0.2 0.4 0.5	
V <sub>IH</sub>	Input High Voltage	Guaranteed Logic HIGH level	Input Pins	2.0		5.5	
V <sub>IL</sub>	Input Low Voltage	Guaranteed Logic LOW level	Input Pins	-0.5		0.8	
I <sub>IH</sub>	Input High Current	V <sub>CC</sub> = Max	V <sub>IN</sub> = V <sub>CC</sub> (Input Pins)	-1		1	µA
I <sub>IL</sub>	Input Low Current	V <sub>CC</sub> = Max	V <sub>IN</sub> = GND (Input & I/O Pins)	-1		1	
I <sub>OZH</sub>	High Impedance Output Current	V <sub>CC</sub> = Max., All outputs Disabled	V <sub>OUT</sub> = V <sub>CC</sub> V <sub>OUT</sub> = GND	-1		1	
I <sub>OZL</sub>	High Impedance Output Current	V <sub>CC</sub> = Max., All outputs Disabled	V <sub>OUT</sub> = V <sub>CC</sub> V <sub>OUT</sub> = GND	-1		1	
V <sub>IK</sub>	Clamp Diode Voltage	V <sub>CC</sub> = Min., I <sub>IN</sub> = -18mA			-0.7	-1.2	V
I <sub>ODH</sub>	Output HIGH Current	V <sub>OUT</sub> = 3.3V, V <sub>IN</sub> = V <sub>IL</sub> or V <sub>IH</sub> , V <sub>OUT</sub> = 1.5V <sup>(4)</sup>		-35	-86	-110	mA
I <sub>ODL</sub>	Output LOW Current	V <sub>OUT</sub> = 3.3V, V <sub>IN</sub> = V <sub>IL</sub> or V <sub>IH</sub> , V <sub>OUT</sub> = 1.5V <sup>(4)</sup>		50	168	200	
I <sub>OS</sub>	Short Circuit <sup>(5)</sup> Current	V <sub>CC</sub> = Max., V <sub>OUT</sub> = GND <sup>(5)</sup>		-60	-135	-240	
V <sub>H</sub>	Input Hysteresis				150		mV

**Note:**

1. For Max. or Min. conditions, use appropriate value specified under Electrical Characteristics for the applicable device type.
2. Typical values are at V<sub>CC</sub> = 3.3V, +25°C ambient and maximum loading.
3. V<sub>OH</sub> = V<sub>CC</sub> - 0.6V at rated current.
4. This parameter is determined by device characterization but is not production tested.
5. Not more than one output should be shorted at one time. Duration of the test should not exceed one second.

**Power Supply Characteristics** ( $T_A = -40^{\circ}\text{C}$  to  $+85^{\circ}\text{C}$ ,  $V_{CC} = 3.3\text{V} \pm 0.3\text{V}$ )

Parameters	Description	Test Conditions <sup>(1)</sup>		Min.	Typ <sup>(2)</sup>	Max.	Units
$I_{CC}$	Quiescent Power Supply Current	$V_{CC} = \text{Max.}$	$V_{IN} = \text{GND or } V_{CC}$	—		30	$\mu\text{A}$
$\Delta I_{CC}$	Supply Current per Inputs @ TTL HIGH	$V_{CC} = \text{Max.}$	$V_{IN} = V_{CC} - 0.6\text{V}^{(3)}$	—	11	300	
$I_{CCD}$	Supply Current per Input per MHz <sup>(4)</sup>	$V_{CC} = \text{Max.},$ Outputs Open $\overline{\text{OE}}_A$ or $\overline{\text{OE}}_B = \text{GND}$ Per Output Toggling 50% Duty Cycle	$V_{IN} = V_{CC}$ $V_{IN} = \text{GND}$	—	0.1	0.16	mA/ MHz
$I_C$	Total Power Supply Current <sup>(6)</sup>	$V_{CC} = \text{Max.},$ Outputs Open $f_O = 10 \text{ MHz}$ 50% Duty Cycle $\overline{\text{OE}}_A$ or $\overline{\text{OE}}_B = \text{GND}$ Mon. Outputs Toggling	$V_{IN} = V_{CC}$ $V_{IN} = \text{GND}$	—	3.3	9.0 <sup>(5)</sup>	mA
			$V_{IN} = V_{CC} - 0.6\text{V}$ $V_{IN} = \text{GND}$	—	3.3	10.0 <sup>(5)</sup>	
		$V_{CC} = \text{Max.},$ Outputs Open $f_O = 2.5 \text{ MHz}$ 50% Duty Cycle $\overline{\text{OE}}_A$ or $\overline{\text{OE}}_B = \text{GND}$ Eleven Outputs Toggling	$V_{IN} = V_{CC}$ $V_{IN} = \text{GND}$	—	1.8	6.0 <sup>(5)</sup>	
			$V_{IN} = V_{CC} - 0.6\text{V}$ $V_{IN} = \text{GND}$	—	1.8	7.0 <sup>(5)</sup>	

**Note:**

- For Max. or Min. conditions, use appropriate value specified under Electrical Characteristics for the applicable device.
- Typical values are at  $V_{CC} = 3.3\text{V}$ ,  $+25^{\circ}\text{C}$  ambient.
- Per TTL driven input ( $V_{IN} = V_{CC} - 0.6\text{V}$ ); all other inputs at  $V_{CC}$  or GND.
- This parameter is not directly testable, but is derived for use in Total Power Supply Calculations.
- Values for these conditions are examples of the  $I_C$  formula. These limits are guaranteed but not tested.

$$I_C = I_{\text{QUIESCENT}} + I_{\text{INPUTS}} + I_{\text{DYNAMIC}}$$

$$I_C = I_{CC} + \Delta I_{CC} D_H N_T + I_{CCD} (f_O N_O)$$

$$I_{CC} = \text{Quiescent Current}$$

$$\Delta I_{CC} = \text{Power Supply Current for a TTL High Input } (V_{IN} = V_{CC} - 0.6\text{V})$$

$$D_H = \text{Duty Cycle for TTL Inputs High}$$

$$N_T = \text{Number of TTL Inputs at } D_H$$

$$I_{CCD} = \text{Dynamic Current Caused by an Input Transition Pair (HLH or LHL)}$$

$$f_O = \text{Output Frequency}$$

$$N_O = \text{Number of Outputs at } f_O$$

All currents are in milliamps and all frequencies are in megahertz.

**Capacitance** ( $T_A = 25^\circ\text{C}$ ,  $f = 1\text{ MHz}$ )

Parameters <sup>(1)</sup>	Description	Test Conditions	Typ	Max.	Units
$C_{IN}$	Input Capacitance	$V_{IN} = 0V$	3.0	6.0	pF
$C_{OUT}$	Output Capacitance	$V_{OUT} = 0V$	6.0	8.0	

**Note:**

1. This parameter is determined by device characterization but is not production tested.

**Switching Characteristics** ( $T_A = -40^\circ\text{C}$  to  $+85^\circ\text{C}$ ,  $V_{CC} = 3.3V \pm 0.3V$ )

Parameter	Description	Test Conditions <sup>(1)</sup>	3805		3805A		3805B		3805C		Units	
			3806		3806A		3806B		3806C			
			Com.	Com.	Com.	Com.	Com.	Com.				
			Min.	Max.	Min.	Max.	Min.	Max.	Min.	Max.		
$t_{PLH}$ $t_{PLH}$	Propagation Delay $IN_A$ to $OA_N$ , $IN_B$ to $OB_N$	$C_L = 50\text{pF}$ $R_L = 500\Omega$		1.5	6.5	1.5	5.8	1.5	5.0	1.5	4.5	ns
$t_{PZH}$ $t_{PZL}$	Output Enable Time $\overline{OE}_A$ to $OA_N$ , $\overline{OE}_B$ to $OB_N$			1.5	8.0	1.5	8.0	1.5	6.5	1.5	6.2	
$t_{PHL}$ $t_{PLZ}$	Output Disable Time $\overline{OE}_A$ to $OA_N$ , $\overline{OE}_B$ to $OB_N$			1.5	7.0	1.5	7.0	1.5	6.0	1.5	5.0	
$t_{SK(o)}$ <sup>(3)</sup>	Skew between two outputs of same package (same transition)				0.7		0.7		0.5		0.5	
$t_{SK(p)}$ <sup>(3)</sup>	Skew between opposite transitions ( $t_{PHL} - t_{PLH}$ ) of the same output				1.0		0.7		0.5		0.5	
$t_{SK(t)}$ <sup>(3)</sup>	Skew between two outputs of different package at same temperature (Same transition)				1.5		1.2		1.0		0.8	

**Note:**

- See test circuit and waveforms
- Minimum limits are guaranteed but not tested on Propagation Delays.
- Skew measured at worst case temperature (max. temp).

## Tests Circuits for All Outputs

Except for  $F_{IN} > 100$  MHz

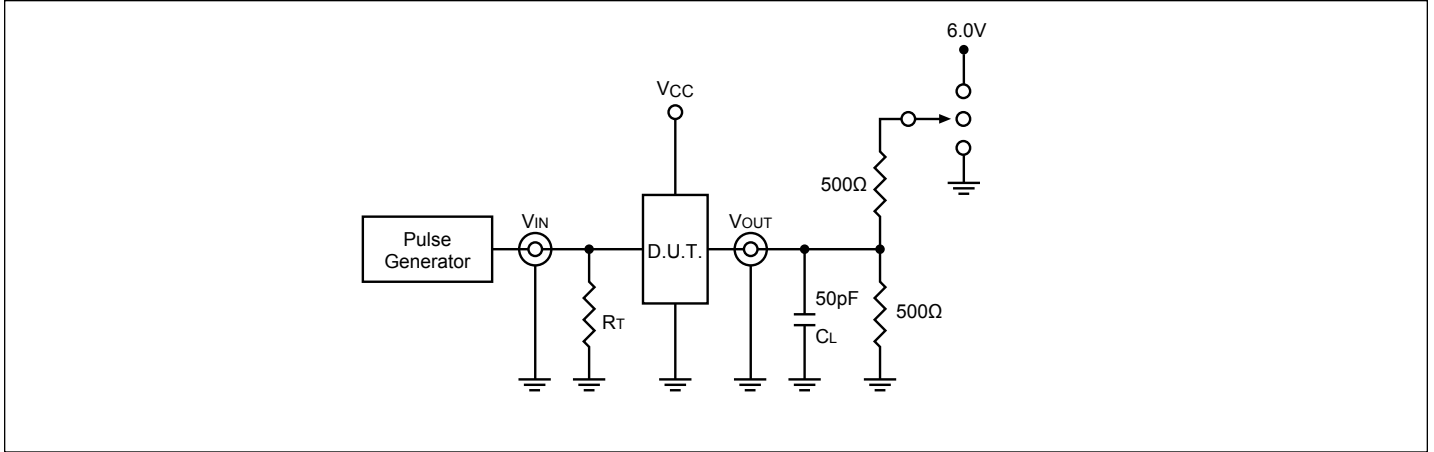

### Switch Position

Test	Switch
Disable LOW	6V
Enable LOW	
Disable HIGH	GND
Enable HIGH	
All Other Inputs	Open

#### Definitions:

$C_L$  = Load capacitance: includes jig and probe capacitance.

$R_T$  = Termination resistance: should be equal to  $Z_{OUT}$  of the Pulse Generator.

**Switching Waveforms**

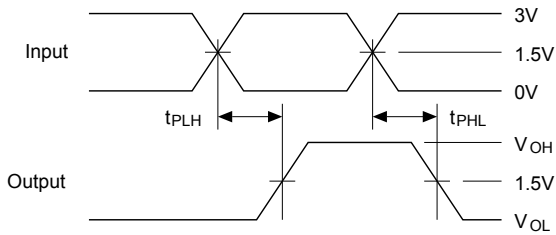

Propagation Delay

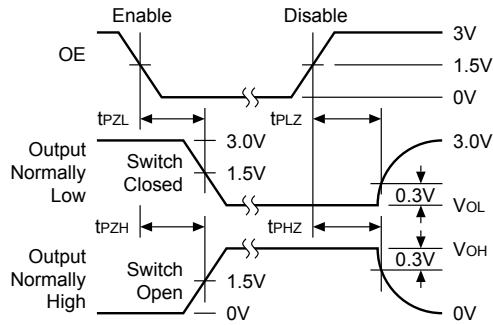

Enable and Disable Times

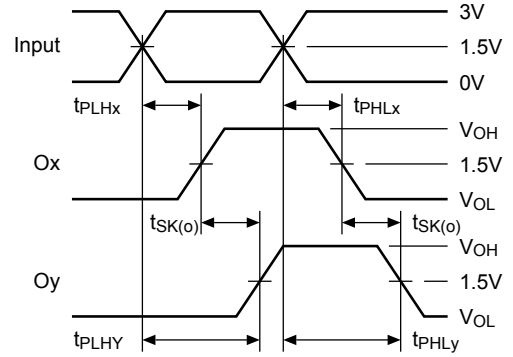

$$t_{SK(O)} = |t_{PLHy} - t_{PLHx}| \text{ or } |t_{PHLx} - t_{PHLy}|$$

Output Skew -  $t_{SK(O)}$

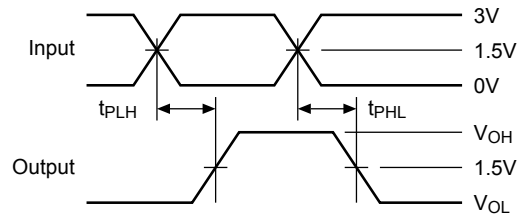

$$t_{SK(P)} = |t_{PHL} - t_{PLH}|$$

Pulse Skew -  $t_{SK(P)}$

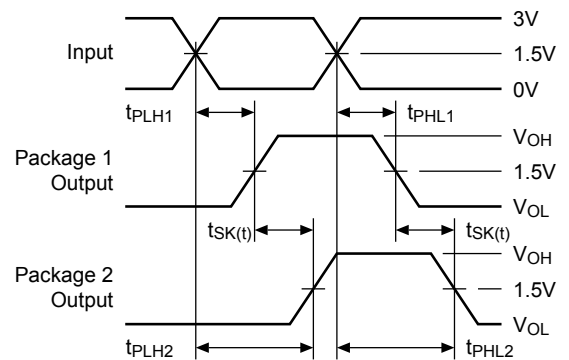

$$t_{SK(t)} = |t_{PLH2} - t_{PLH1}| \text{ or } |t_{PHL2} - t_{PHL1}|$$

Package Skew -  $t_{SK(t)}$

**Part Marking**

PI49FCT3805

Q Package

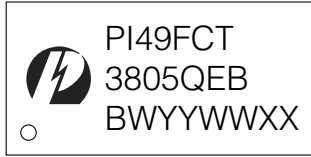

B on the Part# = Speed Code  
B: Fab 2 Port Code  
W: Die Rev  
YY: Year  
WW: Workweek  
1st X: Assembly Code  
2nd X: Fab Code

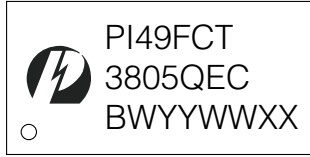

C on the Part# = Speed Code  
B: Fab 2 Port Code  
W: Die Rev  
YY: Year  
WW: Workweek  
1st X: Assembly Code  
2nd X: Fab Code

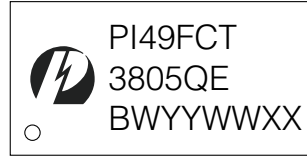

B: Fab 2 Port Code  
W: Die Rev  
YY: Year  
WW: Workweek  
1st X: Assembly Code  
2nd X: Fab Code

H Package



C on the Part# = Speed Code  
B: Fab 2 Port Code  
W: Die Rev  
YY: Year  
WW: Workweek  
1st X: Assembly Code  
2nd X: Fab Code

**Part Marking**

PI49FCT3806

Top mark not available at this time. To obtain advance information regarding the top mark, please contact your local sales representative.

**PI49FCT3805/PI49FCT3806**

**Packaging Mechanical: 20-SSOP (H20)**

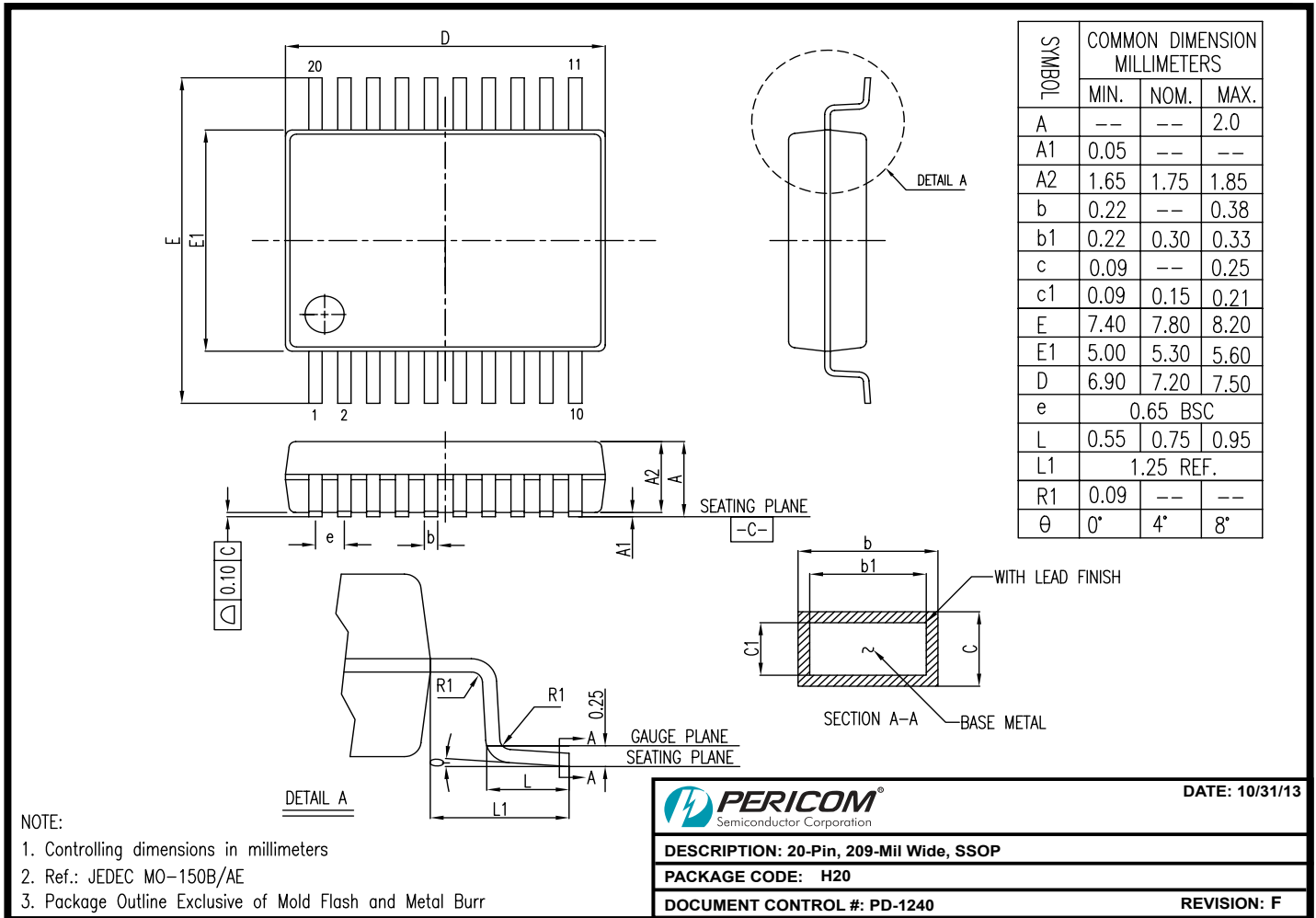

13-0214

**Packaging Mechanical: 20-QSOP (Q)**

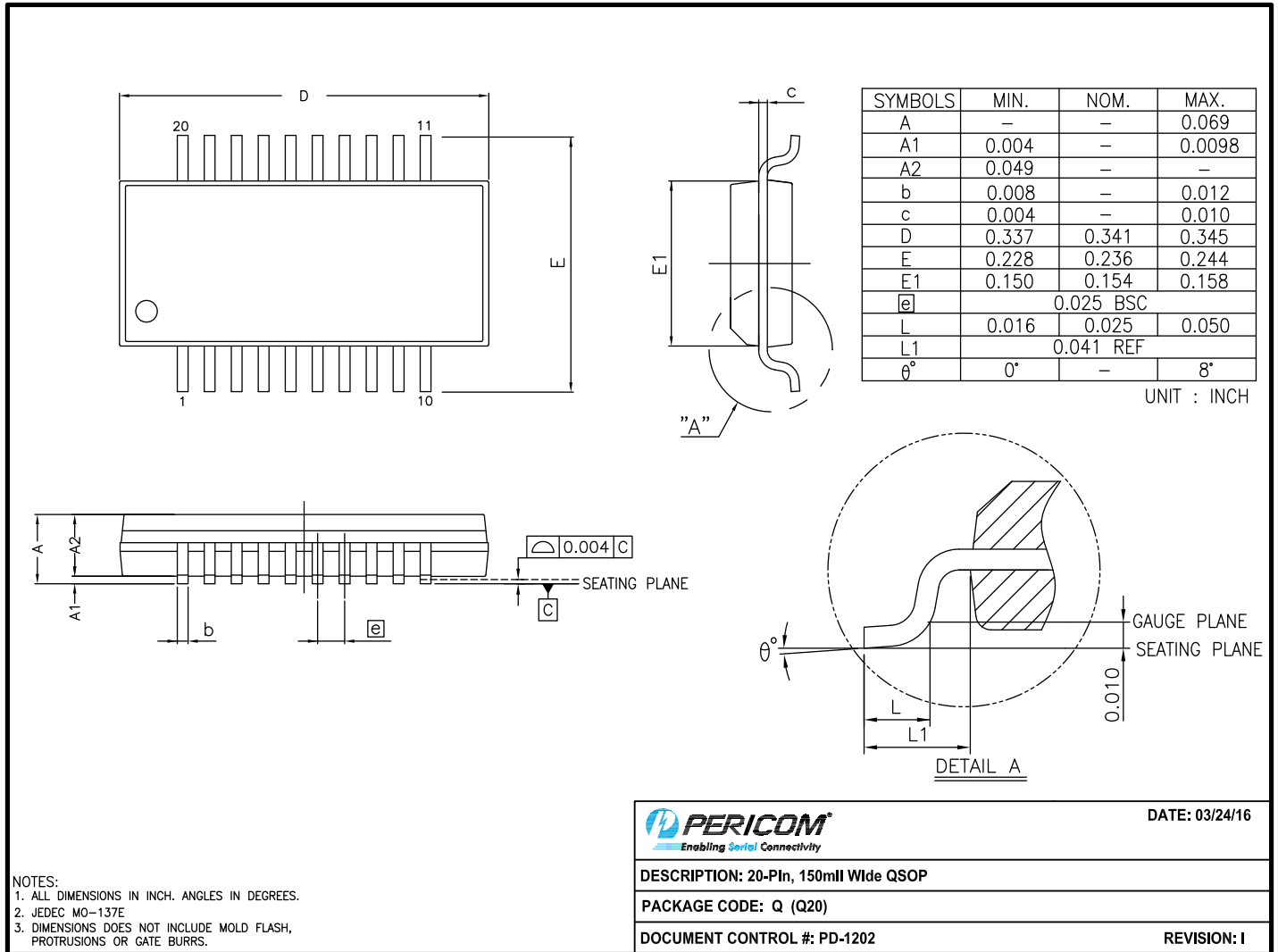

16-0057

**For latest package info.**

please check: <http://www.diodes.com/design/support/packaging/pericom-packaging/packaging-mechanicals-and-thermal-characteristics/>

### PI49FCT3805 Ordering Information

Ordering Code	Package Code	Speed Grade	Package Description
PI49FCT3805BQEX	Q	B	20-pin, 150-mil (QSOP)
PI49FCT3805CHEX	H	C	20-pin, 209-mil (SSOP)
PI49FCT3805CQEX	Q	C	20-pin, 150-mil (QSOP)
PI49FCT3805QEX	Q	Blank	20-pin, 150-mil (QSOP)

### PI49FCT3806 Ordering Information

Ordering Code	Package Code	Speed Grade	Package Description
PI49FCT3806BQEX	Q	B	20-pin, 150-mil (QSOP)

**Notes:**

1. No purposely added lead. Fully EU Directive 2002/95/EC (RoHS), 2011/65/EU (RoHS 2) & 2015/863/EU (RoHS 3) compliant.
2. See <https://www.diodes.com/quality/lead-free/> for more information about Diodes Incorporated's definitions of Halogen- and Antimony-free, "Green" and Lead-free.
3. Halogen- and Antimony-free "Green" products are defined as those which contain <900ppm bromine, <900ppm chlorine (<1500ppm total Br + Cl) and <1000ppm antimony compounds.
4. E = Pb-free and Green
5. X suffix = Tape/Reel

#### IMPORTANT NOTICE

DIODES INCORPORATED MAKES NO WARRANTY OF ANY KIND, EXPRESS OR IMPLIED, WITH REGARDS TO THIS DOCUMENT, INCLUDING, BUT NOT LIMITED TO, THE IMPLIED WARRANTIES OF MERCHANTABILITY AND FITNESS FOR A PARTICULAR PURPOSE (AND THEIR EQUIVALENTS UNDER THE LAWS OF ANY JURISDICTION).

Diodes Incorporated and its subsidiaries reserve the right to make modifications, enhancements, improvements, corrections or other changes without further notice to this document and any product described herein. Diodes Incorporated does not assume any liability arising out of the application or use of this document or any product described herein; neither does Diodes Incorporated convey any license under its patent or trademark rights, nor the rights of others. Any Customer or user of this document or products described herein in such applications shall assume all risks of such use and will agree to hold Diodes Incorporated and all the companies whose products are represented on Diodes Incorporated website, harmless against all damages.

Diodes Incorporated does not warrant or accept any liability whatsoever in respect of any products purchased through unauthorized sales channel.

Should Customers purchase or use Diodes Incorporated products for any unintended or unauthorized application, Customers shall indemnify and hold Diodes Incorporated and its representatives harmless against all claims, damages, expenses, and attorney fees arising out of, directly or indirectly, any claim of personal injury or death associated with such unintended or unauthorized application.

Products described herein may be covered by one or more United States, international or foreign patents pending. Product names and markings noted herein may also be covered by one or more United States, international or foreign trademarks.

This document is written in English but may be translated into multiple languages for reference. Only the English version of this document is the final and definitive format released by Diodes Incorporated.

#### LIFE SUPPORT

Diodes Incorporated products are specifically not authorized for use as critical components in life support devices or systems without the express written approval of the Chief Executive Officer of Diodes Incorporated. As used herein:

A. Life support devices or systems are devices or systems which:

1. are intended to implant into the body, or

2. support or sustain life and whose failure to perform when properly used in accordance with instructions for use provided in the labeling can be reasonably expected to result in significant injury to the user.

B. A critical component is any component in a life support device or system whose failure to perform can be reasonably expected to cause the failure of the life support device or to affect its safety or effectiveness.

Customers represent that they have all necessary expertise in the safety and regulatory ramifications of their life support devices or systems, and acknowledge and agree that they are solely responsible for all legal, regulatory and safety-related requirements concerning their products and any use of Diodes Incorporated products in such safety-critical, life support devices or systems, notwithstanding any devices- or systems-related information or support that may be provided by Diodes Incorporated. Further, Customers must fully indemnify Diodes Incorporated and its representatives against any damages arising out of the use of Diodes Incorporated products in such safety-critical, life support devices or systems.

Copyright © 2020, Diodes Incorporated

[www.diodes.com](http://www.diodes.com)

## Looking for pricing, stock, or lifecycle information?

Click below to explore more details on WIN SOURCE:

 [View PI49FCT3805BQE on WIN SOURCE](#)

 [Diodes Incorporated](#) Information

## Optimize Your Supply Chain with WIN SOURCE Solutions

-  Global Sourcing Solution
-  Obsolete Management
-  Cost Control Management
-  Shortage Management
-  Alternative Solution
-  Excess Inventory Management