



**THE DATASHEET OF
PI3USB10MZKE+DMX**



4.2V, Wide Bandwidth, 2-Channel, 2:1 Mux/DeMux USB 2.0 Switch w/ Single Select

Features

- USB 2.0 compliant
- R_{ON} is 4Ω typical
- Low bit-to-bit skew
- Low Crosstalk: -31dB @ 250 MHz
- Near-Zero propagation delay: 250ps
- Switching speed: 9ns
- Channel On Capacitance: 6pF (typical)
- V_{DD} Operating Range: 2.7V to 5.0V
- ESD $>2000\text{V}$. . . Human Body Model
- >700 MHz bandwidth (or data frequency)
- Packaging (Pb-free & Green):
 - 12-contact, 1.6mm x 2.2mm, TQFN (ZK12)
 - 12-contact, 3mm x 3.5mm, TDFN (ZE12)

Application

- Routes signals for USB 2.0
- Hand held devices

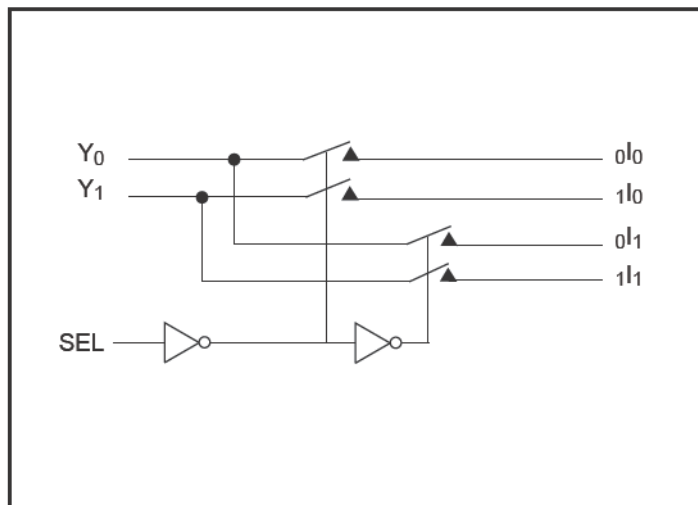
Block Diagram

Truth Table

Function	SEL
Y_n to nI_o	L
Y_n to nI_1	H

Description

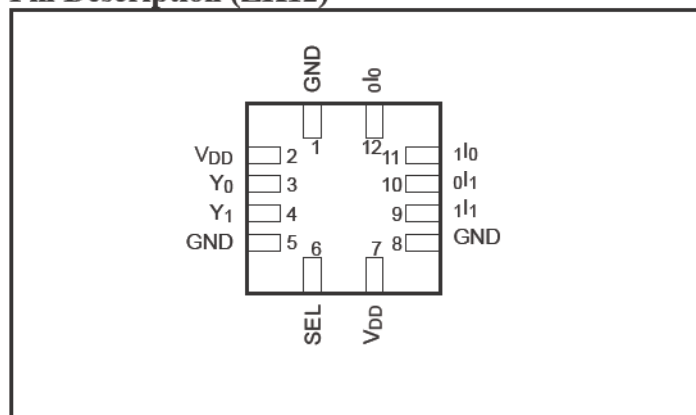
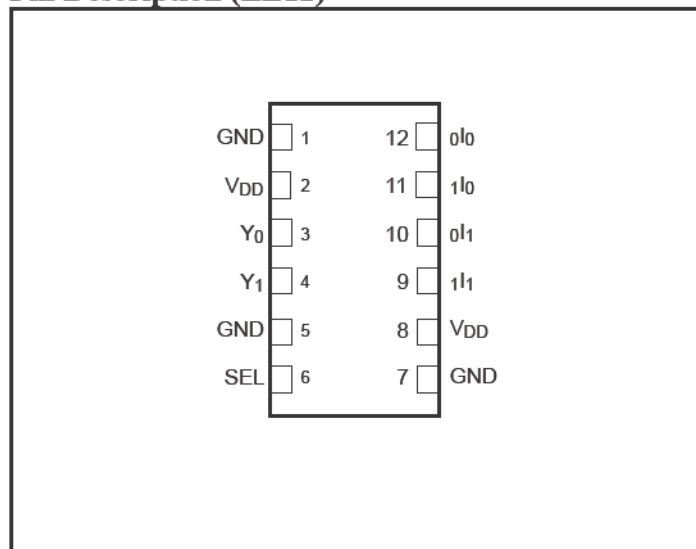
The PI3USB10M is a single differential channel 2:1 multiplexer/demultiplexer USB 2.0 Switch. Industry leading advantages include a propagation delay of less than 250ps, resulting from its low channel resistance and I/O capacitance. The device multiplexes differential outputs from a USB Host device to one of two corresponding outputs. The switch is bidirectional and offers little or no attenuation of the high-speed signals at the outputs. It is designed for low bit-to-bit skew, high channel-to-channel noise isolation and is compatible with various standards, such as High Speed USB 2.0 (480 Mb/s).

Pin Description (ZK12)

Pin Description (ZE12)

Maximum Ratings

(Above which useful life may be impaired. For user guidelines, not tested.)

Storage Temperature	-65°C to +150°C
Supply Voltage to Ground Potential	-0.5V to +5.25V
DC Input Voltage	-0.5V to +5.5V
DC Output Current	120mA
Power Dissipation	0.5W

Note: Stresses greater than those listed under MAXIMUM RATINGS may cause permanent damage to the device. This is a stress rating only and functional operation of the device at these or any other conditions above those indicated in the operational sections of this specification is not implied. Exposure to absolute maximum rating conditions for extended periods may affect reliability.

DC Electrical Characteristics for USB 2.0 Switching over Operating Range

($T_A = -40^\circ\text{C}$ to $+85^\circ\text{C}$, $V_{DD} = 3.0\text{V} - 4.4\text{V}$)

Parameter	Description	Test Conditions ⁽¹⁾	Min.	Typ. ⁽²⁾	Max.	Units
V_{IH}	Input HIGH Voltage	Guaranteed HIGH level	$V_{DD} = 4.2\text{V}$	2.0		V
			$V_{DD} = 3.3\text{V}$	1.6		
V_{IL}	Input LOW Voltage	Guaranteed HIGH level			0.8	
V_{IK}	Clamp Diode Voltage	$V_{DD} = \text{Max.}, I_{IN} = -18\text{mA}$		-0.7	-1.2	
I_{IH}	Input HIGH Current	$V_{DD} = \text{Max.}, V_{IN} = V_{DD}$			± 5	μA
I_{IL}	Input LOW Current	$V_{DD} = \text{Max.}, V_{IN} = \text{GND}$			± 5	
R_{ON}	Switch On-Resistance ⁽³⁾	$V_{DD} = \text{Min.}, 1.25\text{V} \leq V_{IN} \leq V_{DD}, I_{IN} = -40\text{mA}$		4.0	6.5	Ω
$R_{FLAT(ON)}$	On-Resistance Flatness ⁽³⁾	$V_{DD} = \text{Min.}, V_{IN} @ 1.5\text{V}$ and $V_{DD} I_{IN} = -40\text{mA}$		1.0		
ΔR_{ON}	On-Resistance match from center ports to any other port ⁽³⁾	$V_{DD} = \text{Min.}, 1.5\text{V} \leq V_{IN} \leq V_{DD}, I_{IN} = -40\text{mA}$		0.9	2.0	

Notes:

- For max. or min. conditions, use appropriate value specified under Electrical Characteristics for the applicable device type.
- $V_{DD} = 3.0 - 4.4\text{V}$, $T_A = 25^\circ\text{C}$ ambient and maximum loading.
- Measured by the voltage drop between Y and In pin at indicated current through the Switch-On-Resistance is determined by the lower of the voltages on the two (Y, In) pins.

Power Supply Characteristics ($V_{DD} = 3.0 - 4.4\text{V}$)

Parameters	Description	Test Conditions ⁽¹⁾	Min.	Typ.	Max.	Units
I_{DD}	Quiescent Power Supply Current	$V_{DD} = \text{Max.}, V_{IN} = \text{GND or } V_{DD}$			800	μA

Notes:

- For max. or min. conditions, use appropriate value specified under Electrical Characteristics for the applicable device type.

DC Electrical Characteristics for USB 2.0 Switching over Operating Range

($T_A = -40^\circ\text{C}$ to $+85^\circ\text{C}$, $V_{DD} = 5.0\text{V}$)

Parameter	Description	Test Conditions ⁽¹⁾	Min.	Typ. ⁽²⁾	Max.	Units
V_{IH}	Input HIGH Voltage	Guaranteed HIGH level	$V_{DD} = 4.2\text{V}$	2.0		V
			$V_{DD} = 3.3\text{V}$	1.6		
V_{IL}	Input LOW Voltage	Guaranteed HIGH level			0.8	
V_{IK}	Clamp Diode Voltage	$V_{DD} = \text{Max.}, I_{IN} = -18\text{mA}$		-0.7	-1.2	
I_{IH}	Input HIGH Current	$V_{DD} = \text{Max.}, V_{IN} = V_{DD}$			± 5	μA
I_{IL}	Input LOW Current	$V_{DD} = \text{Max.}, V_{IN} = \text{GND}$			± 5	
R_{ON}	Switch On-Resistance ⁽³⁾	$V_{DD} = \text{Min.}, 1.25\text{V} \leq V_{IN} \leq V_{DD}, I_{IN} = -40\text{mA}$		4.0	6.5	Ω
$R_{FLAT(ON)}$	On-Resistance Flatness ⁽³⁾	$V_{DD} = \text{Min.}, V_{IN} @ 1.5\text{V}$ and $V_{DD} I_{IN} = -40\text{mA}$		1.0		
ΔR_{ON}	On-Resistance match from center ports to any other port ⁽³⁾	$V_{DD} = \text{Min.}, 1.5\text{V} \leq V_{IN} \leq V_{DD}, I_{IN} = -40\text{mA}$		0.9	2.0	

Notes:

- For max. or min. conditions, use appropriate value specified under Electrical Characteristics for the applicable device type.
- $V_{DD} = 3.0 - 4.4\text{V}$, $T_A = 25^\circ\text{C}$ ambient and maximum loading.
- Measured by the voltage drop between Y and In pin at indicated current through the Switch-On-Resistance is determined by the lower of the voltages on the two (Y, In) pins.

Power Supply Characteristics ($V_{DD} = 5.0\text{V}$)

Parameters	Description	Test Conditions ⁽¹⁾	Min.	Typ.	Max.	Units
I_{DD}	Quiescent Power Supply Current	$V_{DD} = \text{Max.}, V_{IN} = \text{GND}$ or V_{DD}			800	μA

Notes:

- For max. or min. conditions, use appropriate value specified under Electrical Characteristics for the applicable device type.

Capacitance ($T_A = 25^\circ\text{C}$, $f = 1\text{MHz}$)

Parameters ⁽³⁾	Description	Test Conditions ⁽¹⁾	Typ. ⁽²⁾	Max.	Units
C_{IN}	Input Capacitance	$V_{IN} = 0\text{V}$	2	3	pF
C_{OFF}	Port I Capacitance, Switch OFF		4	6	
C_{ON}	Switch Capacitance, Switch ON		7.5	9.5	

Dynamic Electrical Characteristics Over the Operating Range

Parameters	Description	Test Conditions	Min.	Typ. ⁽²⁾	Max.	Units
X_{TALK}	Crosstalk	$R_L = 50\Omega$, $f = 250\text{MHz}$		-31		dB
O_{IRR}	OFF Isolation			-39		
BW	Bandwidth -3dB	$R_L = 50\Omega$		700		MHz

Notes:

1. For max. or min. conditions, use appropriate value specified under Electrical Characteristics for the applicable device type.
2. Typical values are at $V_{DD} = 3.3\text{V}$, $T_A = 25^\circ\text{C}$ ambient and maximum loading.
3. This parameter is determined by device characterization but is not production tested.

Switching Characteristics ($T_A = -40^\circ\text{C}$ to $+85^\circ\text{C}$, $V_{DD} = 3.0\text{V}$ to 4.4V)

Parameters	Description	Test ⁽¹⁾ Conditions	Min.	Typ.	Max.	Units
t_{PD}	Propagation Delay ^(2,3)	See Test Circuit for Electrical Characteristics		0.15		ns
t_{PZH} , t_{PZL}	Line Enable Time - SEL to Y_N , N_I0 , I_N		0.5		15.0	
t_{PHZ} , t_{PLZ}	Line Disable Time - SEL to Y_N , N_I0 , I_N		0.5		9.0	
t_{SKC-C}	Output skew, channel-to-channel ⁽²⁾			3.5	14	ps
t_{SKb-b}	Output skew, bit-to-bit (opposite transition of the same output (t_{PHL} - t_{PLH}) ⁽²⁾)			7.5	20	

Notes:

1. For max. or min. conditions, use appropriate value specified under Electrical Characteristics for the applicable device type.
2. Guaranteed by design.
3. The switch contributes no propagational delay other than the RC delay of the On-Resistance of the switch and the load capacitance. The time constant for the switch alone is of the order of 0.25ns for 10pF load. Since this time constant is much smaller than the rise/fall times of typical driving signals, it adds very little propagational delay to the system. Propagational delay of the USB switch when used in a system is determined by the driving circuit on the driving side of the switch and its interactions with the load on the driven side.

Test Circuit for Dynamic Electrical Characteristics

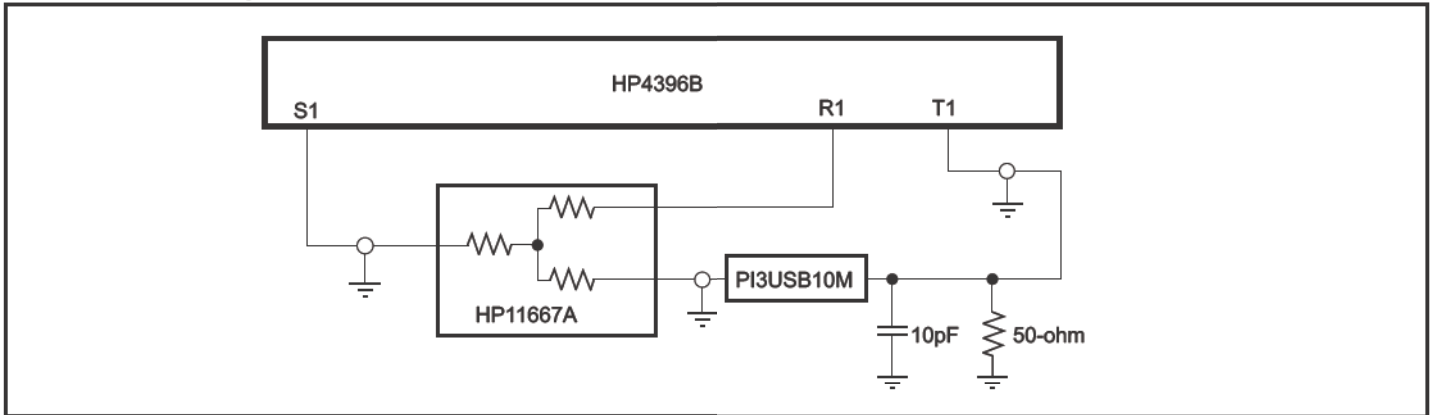

Test Circuit for Electrical Characteristics

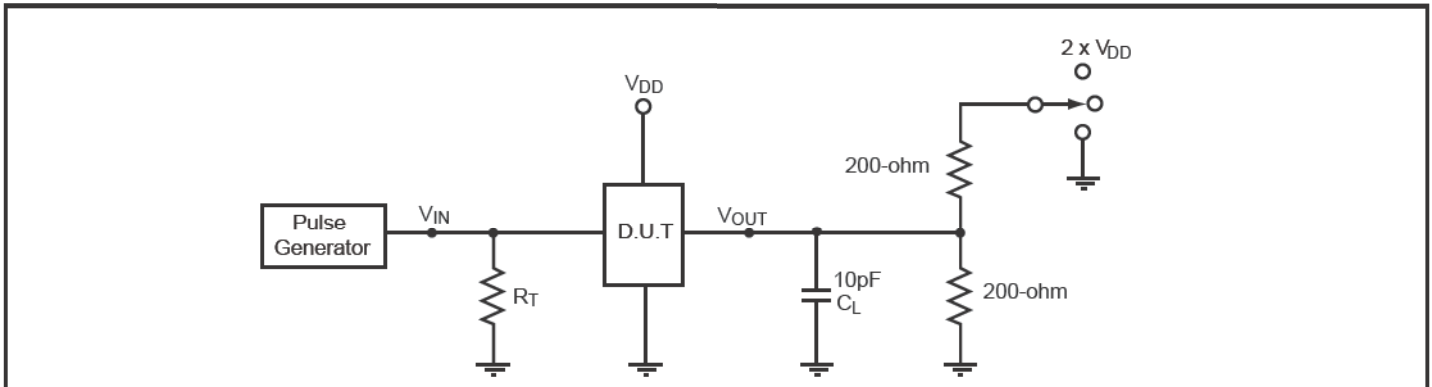

Notes:

- C_L = Load capacitance: includes jig and probe capacitance.
- R_T = Termination resistance: should be equal to Z_{OUT} of the Pulse Generator
- Waveform 1 is for an output with internal conditions such that the output is low except when disabled by the output control.
- Waveform 2 is for an output with internal conditions such that the output is high except when disabled by the output control.
- All input impulses are supplied by generators having the following characteristics: $PRR \leq \text{MHz}$, $Z_O = 50\Omega$, $t_R \leq 2.5\text{ns}$, $t_F \leq 2.5\text{ns}$.
- The outputs are measured one at a time with on transition per measurement.

Switch Positions

Test	Switch
t_{PLZ} , t_{PZL} (output on I-side)	$2 \times V_{DD}$
t_{PHZ} , t_{PZH} (output on I-side)	GND
Prop Delay	Open

Application Information

Logic Inputs

The logic control inputs can be driven up to +3.6V regardless of the supply voltage. For example, given a +3.3V supply, the output enables or select pins may be driven low to 0V and high to 3.6V. Driving IN Rail-to-Rail® minimizes power consumption.

Rail-to-Rail is a registered trademark of Nippon Motorola, Ltd

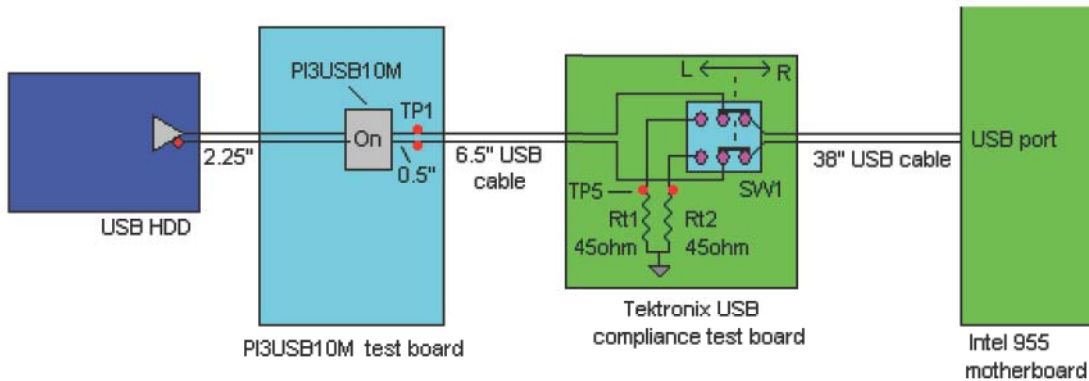

Figure 1: USB 2.0 High-Speed (480Mbps) Signal Integrity Test Setup

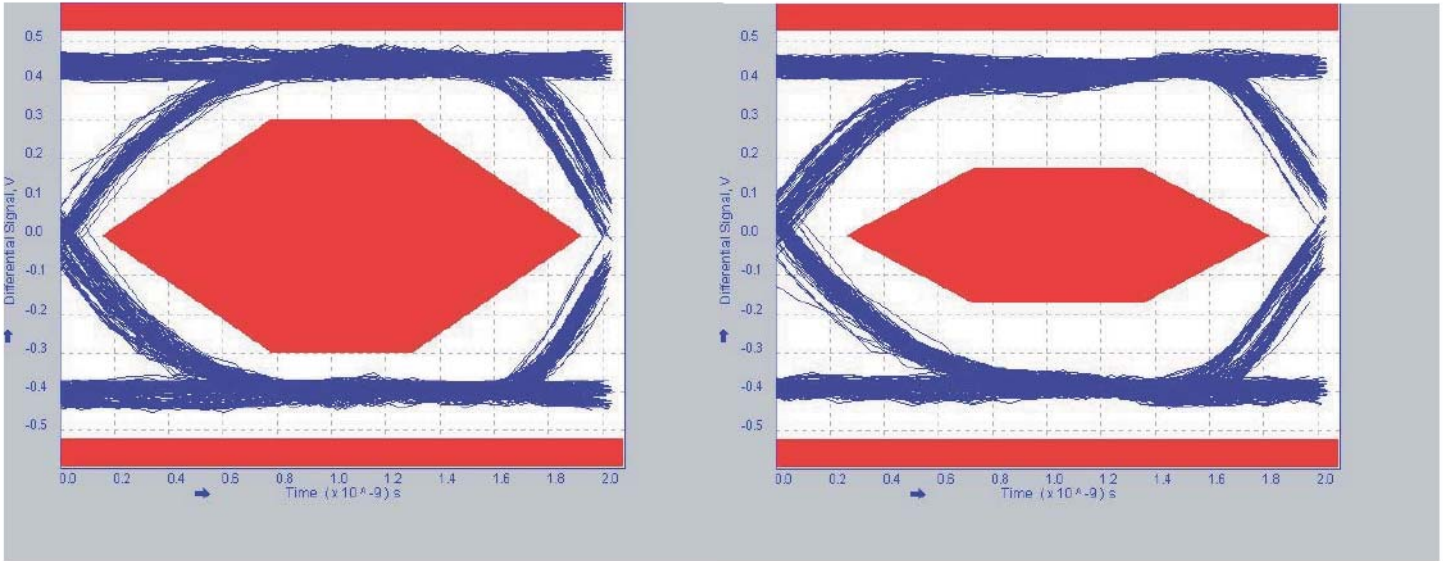

Figure 2: USB 2.0 High-Speed (480Mbps) TP1, left eye, and TP5, right eye, tested with no PI3USB10M in the signal path

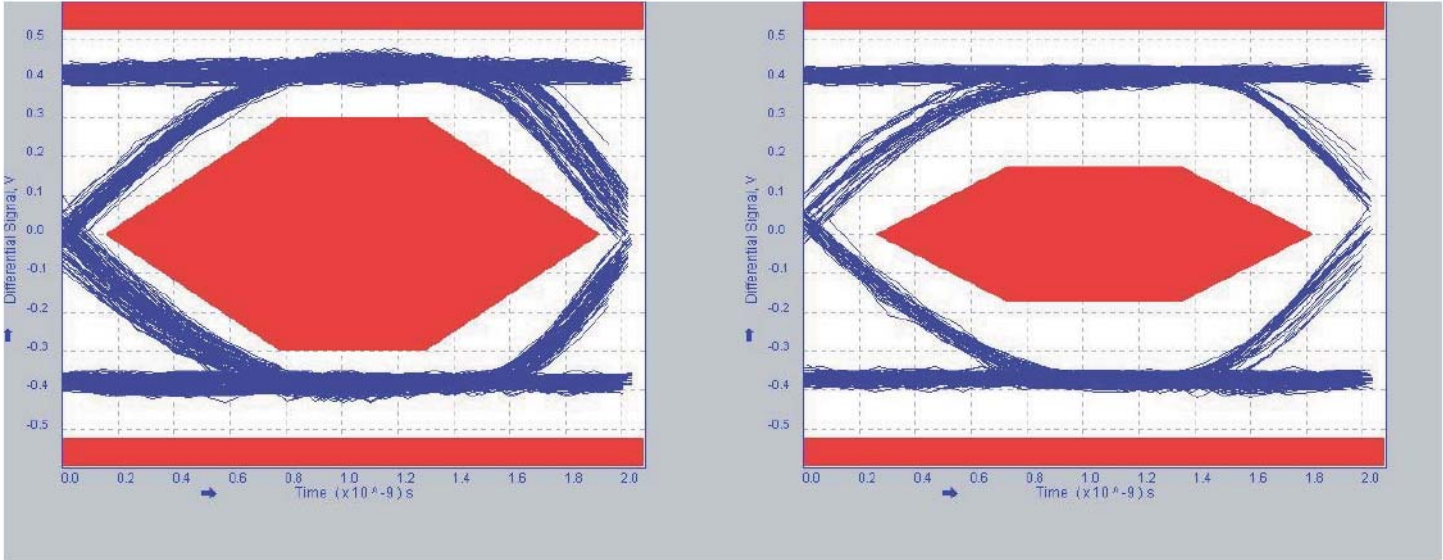
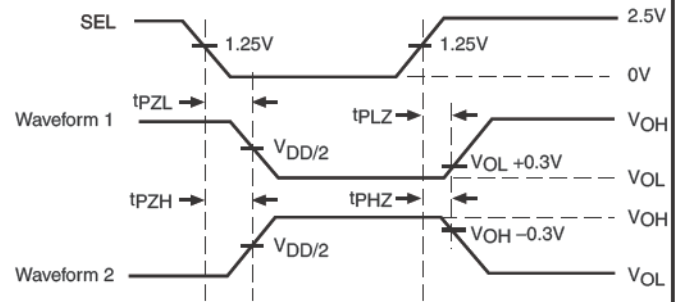
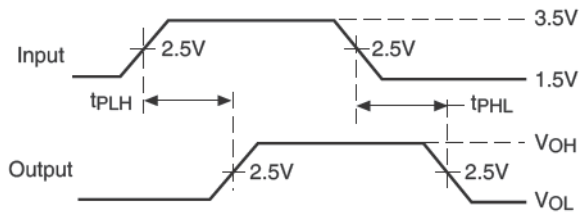
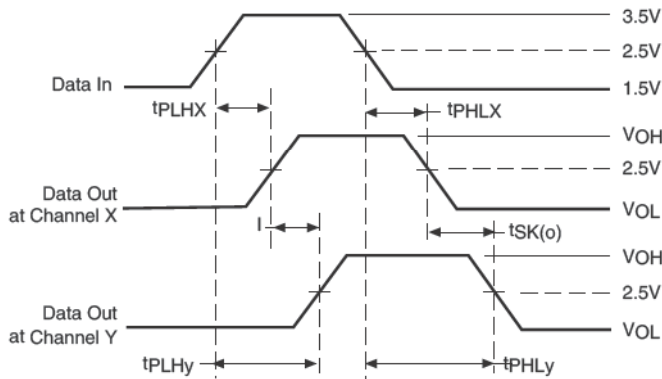

Figure 3: USB 2.0 High-Speed (480Mbps) TP1, left eye, and TP5, right eye, tested with PI3USB10M data signals connected

Switching Waveforms



Voltage Waveforms Propagation Delay Times



$$t_{SK(o)} = |t_{PLHy} - t_{PLHx}| \text{ or } |t_{PHLy} - t_{PHLx}|$$

Output Skew - $t_{SK(o)}$

Voltage Waveforms Enable and Disable Times

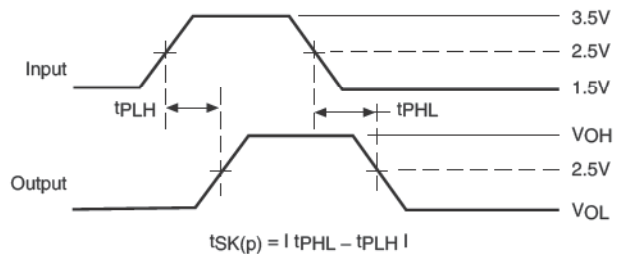

Pulse Skew - $t_{SK(p)}$

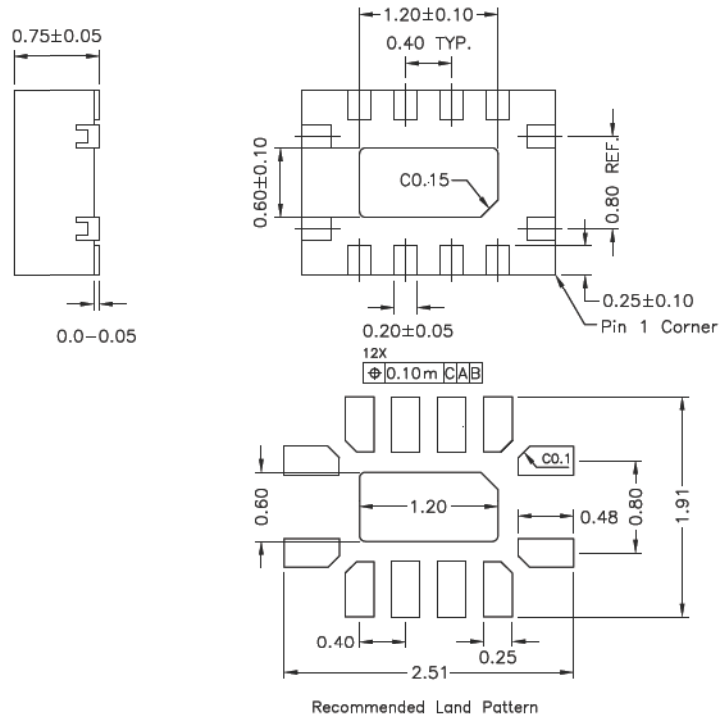
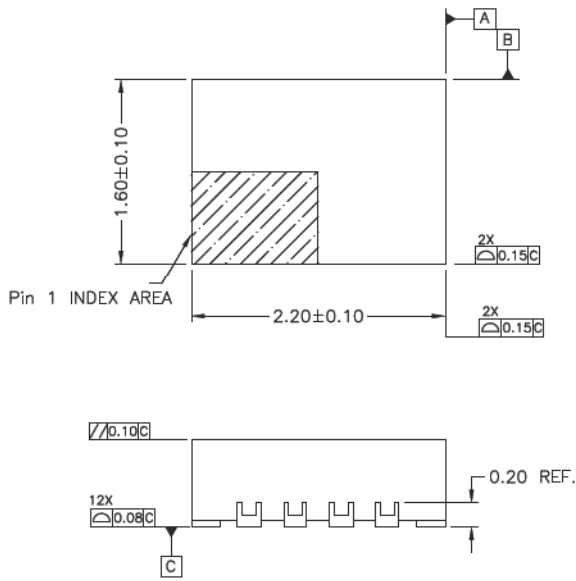

Notes:

- 1) All dimensions are in millimeters, angles in degrees
- 2) Coplanarity applies to the exposed pad as well as the terminals
- 3) Ref JEDEC: MO-241

	DATE: 04/19/06
DESCRIPTION: 12-contact, Thin Quad Flat No Lead (TQFN)	
PACKAGE CODE: ZK12	
DOCUMENT CONTROL #: PD-2059	REVISION: -

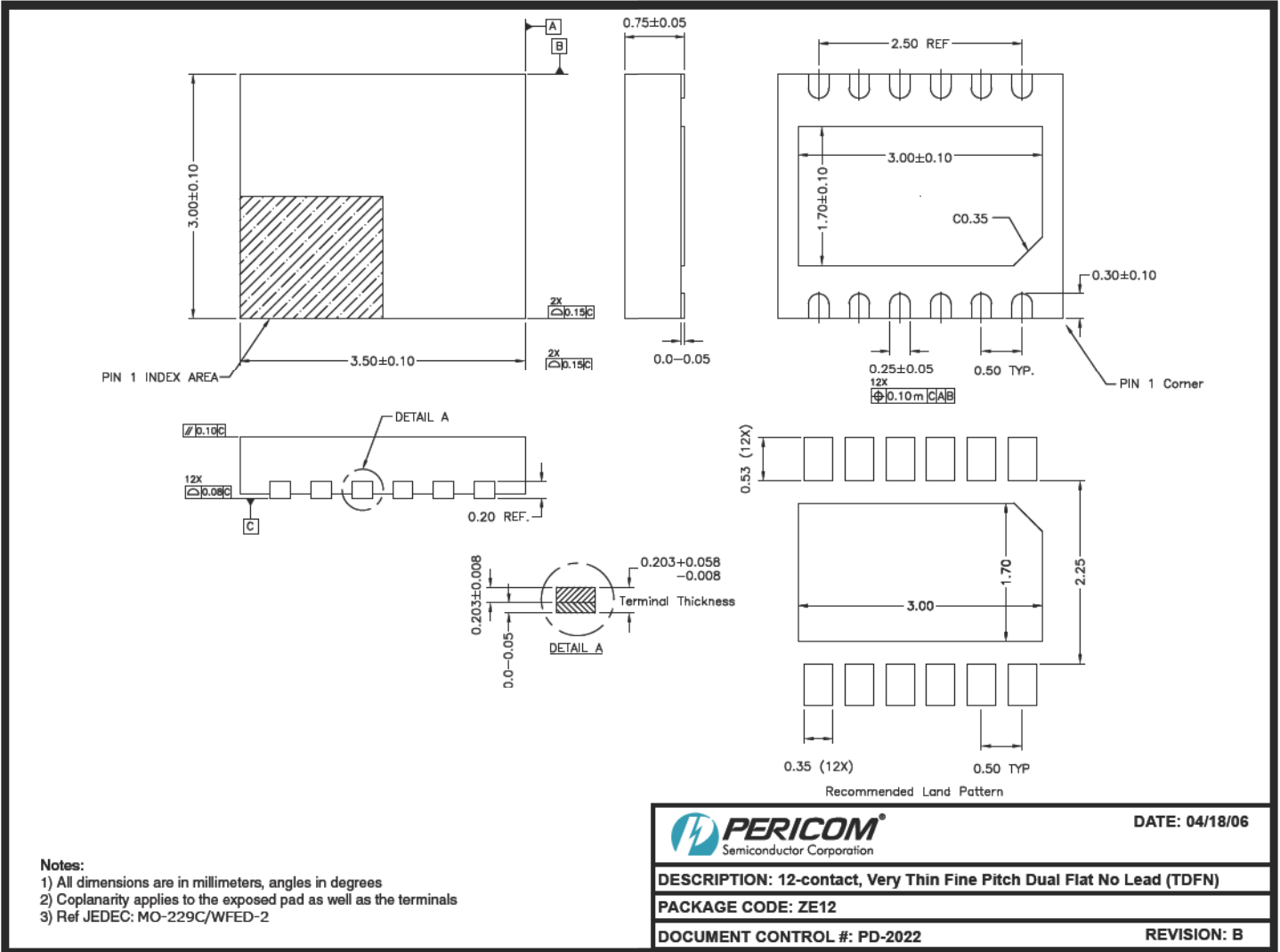

Ordering Information

Ordering Code	Package Code	Package Description	Top Marking
PI3USB10MZKE	ZK	Pb-free & Green, 12-contact TQFN	UM
PI3USB10MZEE	ZE	Pb-free & Green, 12-contact TDFN	YK

Notes:

- Thermal characteristics can be found on the company web site at www.pericom.com/packaging/
- E = Pb-free and Green
- Adding an X suffix = Tape/Reel

Looking for pricing, stock, or lifecycle information?

Click below to explore more details on WIN SOURCE:

 [View PI3USB10MZKE+DMX on WIN SOURCE](#)

 [Diodes Incorporated](#) Information

Optimize Your Supply Chain with WIN SOURCE Solutions

-  Global Sourcing Solution
-  Obsolete Management
-  Cost Control Management
-  Shortage Management
-  Alternative Solution
-  Excess Inventory Management