



**THE DATASHEET OF
PI3PCIE3212XUAEX**



PI3PCIE3212

3.3V, PCI Express® 3.0, 1-Lane, 2-Channel, 8Gbps, 2:1 Mux/DeMux Switch w/ Single Enable

Features

- 2-Differential Channel, 2:1 Mux/DeMux
- PCI Express® 3.0 performance, 8.0Gbps
- Bidirectional operation
- 3dB Bandwidth: 8.1GHz
- Low Bit-to-Bit Skew, 10ps max
- Low Channel-to-Channel skew: 20ps max
- Low Insertion Loss: -1.7dB @4GHz (8.0Gbps)
- Low Return Loss: -13.5dB @4GHz (8.0Gbps)
- Low Crosstalk: -32dB@4GHz (8.0Gbps)
- Low Off Isolation: -21dB@4GHz (8.0Gbps)
- Supply Voltage: 3.3V ± 10%
- Industrial Temperature Range: -40°C to 85°C
- Low Current: 0.2mA typ.
- Totally Lead-Free & Fully RoHS Compliant (Notes 1 & 2)
- Halogen- and Antimony-Free. "Green" Device (Note 3)
- For automotive applications requiring specific change control (i.e. parts qualified to AEC-Q100/101/200, PPAP capable, and manufactured in IATF 16949 certified facilities), please [contact us](https://www.diodes.com/contact-us) or your local Diodes representative. <https://www.diodes.com/quality/product-definitions/>
- Packaging (Pb-free & Green):
 - - 20-contact TQFN (2.5 × 4.5mm)
 - - 18 contact, X2QFN(XUA18), 2x2mm

Description

The PI3PCIE3212 is a PCIe Gen3.0, 8Gbps, 4-to-2 differential, bidirectional-channel multiplexer/demultiplexer switch. This product is ideal for PCI Express® 3.0 signal switching at 8.0Gbps due to its low bit-to-bit skew, high channel-to-channel noise isolation, and bandwidth.

Applications

The PI3PCIE3212 switches a PCI Express 3.0 lane output between two PCI Express lane inputs. Applications include NBs, PCs, servers, and other embedded devices. The PI3PCIE3212 can route PCI Express 3.0, DP1.2, USB3.0, SAS2.0, SATA3.0, XAUI, RXAUI signals with low signal attenuation.

Truth Table

Function	SEL	PD
A to B	L	L
A to C	H	L
All ports Hi-Z, IC Power Down	X	H

Block Diagram

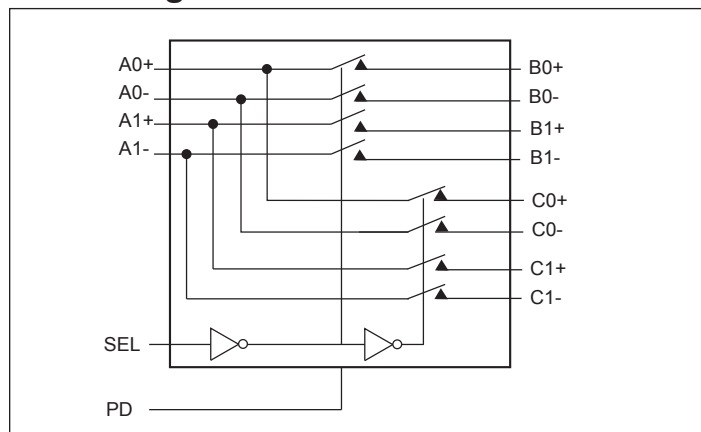

Notes:

1. No purposely added lead. Fully EU Directive 2002/95/EC (RoHS), 2011/65/EU (RoHS 2) & 2015/863/EU (RoHS 3) compliant.
2. See <https://www.diodes.com/quality/lead-free/> for more information about Diodes Incorporated's definitions of Halogen- and Antimony-free, "Green" and Lead-free.
3. Halogen- and Antimony-free "Green" products are defined as those which contain <900ppm bromine, <900ppm chlorine (<1500ppm total Br + Cl) and <1000ppm antimony compounds.

Pin Configuration (Top-side view)

20-contact TQFN

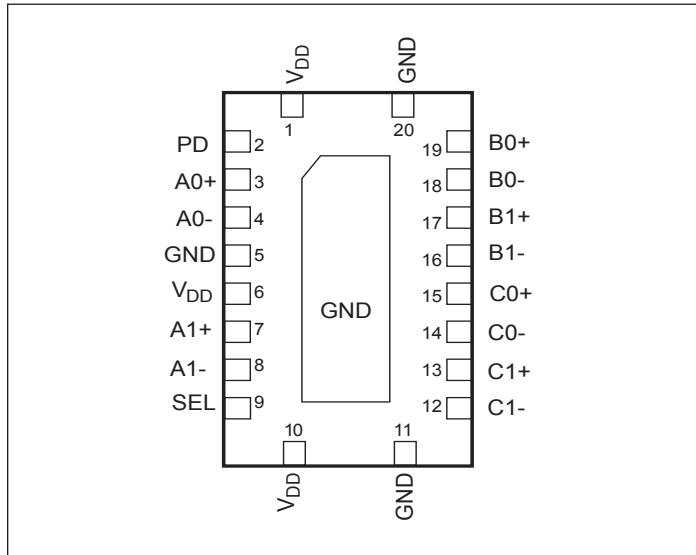

18-contact X2QFN

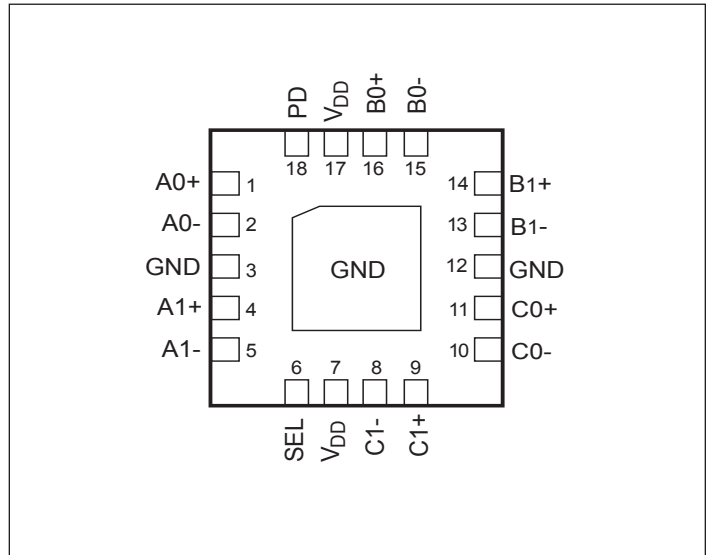

Pin Description

20-TQFN Pin #	18-X2QFN Pin #	Pin Name	I/O	Description
3	1	A0+	I/O	Signal I/O, Channel 0, Port A
4	2	A0-		
7	4	A1+	I/O	Signal I/O, Channel 1, Port A
8	5	A1-		
19	16	B0+	I/O	Signal I/O, Channel 0, Port B
18	15	B0-		
17	14	B1+	I/O	Signal I/O, Channel 1, Port B
16	13	B1-		
15	11	C0+	I/O	Signal I/O, Channel 0, Port C
14	10	C0-		
13	9	C1+	I/O	Signal I/O, Channel 1, Port C
12	8	C1-		
9	6	SEL	I	Operation mode Select (when SEL=0: A→B, when SEL=1: A→C)
2	18	PD	I	PD = 1, Power down is enabled. Please see Truth Table.
1, 6, 10	7, 17	V _{DD}	Pwr	3.3V ±10% Positive Supply Voltage
5, 11, 20	3, 12, Center Pad	GND	Pwr	Power ground

Maximum Ratings

(Above which useful life may be impaired. For user guidelines, not tested.)

Storage Temperature	-65°C to +150°C
Supply Voltage to Ground Potential	-0.5V to +4.6V
Channel DC Input Voltage	-0.5V to 1.5V
DC Output Current	120mA
Power Dissipation	0.5W
SEL/PD DC Input Voltage	-0.5V to 4.6V
Junction Temperature.....	125°C
ESD (HBM)	2kV

Note:

Stresses greater than those listed under MAXIMUM RATINGS may cause permanent damage to the device. This is a stress rating only and functional operation of the device at these or any other conditions above those indicated in the operational sections of this specification is not implied. Exposure to absolute maximum rating conditions for extended periods may affect reliability.

Electrical Characteristics

Recommended Operating Conditions

Symbol	Parameter	Conditions	Min.	Typ.	Max.	Units
V _{DD}	3.3V Power Supply		3.0	3.3	3.6	V
I _{DD}	Total current from V _{DD} 3.3V supply	SEL = OV or V _{DD}		0.2	1	mA
I _{DD_PD}	Power down current	PD = 1		20	40	μA
V _{I/O-DIF}	Differential Voltage (differential pins)				1.6	V _{ppd}
V _{I/O-CM}	Common Mode Voltage (differential pins)		0		0.8	v
T _A	Operating temperature range		-40		85	°C

DC Electrical Characteristics for Switching over Operating Range

Parameters	Description	Test Conditions ⁽¹⁾	Min.	Typ. ⁽¹⁾	Max.	Units
V _{IH} - SEL, PD	Input HIGH Voltage, SEL, PD Input		2		3.6	V
V _{IL} - SEL, PD	Input LOW Voltage, SEL, PD Input		0		0.8	
V _{IK}	Clamp Diode Voltage	V _{DD} = Max., I _{IN} = -18mA		-0.7	-1.2	μA
I _{IH}	Input HIGH Current, SEL, PD	V _{DD} = Max., V _{IN} = V _{DD}			±5	
I _{IL}	Input LOW Current, SEL, PD	V _{DD} = Max., V _{IN} = 0V			±5	μA
I _{IH}	Input HIGH Current, A _X , B _X , C _X	V _{DD} = Max., V _{IN} = 1.5V	-10		+10	
I _{IL}	Input LOW Current, A _X , B _X , C _X	V _{DD} = Max., V _{IN} = 0V	-10		+10	μA
I _{IOZH}	HighZ HIGH Current, B _X , C _X	V _{DD} = Max., V _{IN} = 1.5V	-10		+10	
I _{IOZL}	HighZ LOW Current, B _X , C _X	V _{DD} = Max., V _{IN} = 0V	-10		+10	μA

Note:

1. Typical values are at V_{DD} = 3.3V, T_A = 25°C ambient and maximum loading.

Switching Characteristics

Parameters	Description	Test Conditions	Min.	Typ.	Max.	Units
tPZH, tPZL	Line Enable Time - SEL to A _N , B _N , C _N			25	30	ns
tPHZ, tPLZ	Line Disable Time - SEL to A _N , B _N , C _N			5	25	
tPLH	Propagation Delay, LOW to HIGH		17		36	ps
tPLL	Propagation Delay, HIGH to LOW		21		39	ps
t _{b-b}	Bit-to-bit skew within the same differential pair			5	10	ps
t _{ch-ch}	Channel-to-channel skew				20	ps

Dynamic Electrical Characteristics

Parameter	Description	Test Conditions	Min.	Typ. ¹	Max.	Units
DDIL ^(2,3)	Differential Insertion Loss (V _{IN} = -10dBm, DC = 0V)	f = 100MHz f = 100MHz-1.25GHz f = 1.25GHz-2.5GHz f = 2.5GHz-4GHz f = 5GHz		-0.4 -0.6 -1.0 -1.7 -2.1		dB
DDIL _{OFF} ^(2,3)	Differential Off Isolation	f = 100MHz f = 100MHz-1.25GHz f = 1.25GHz-2.5GHz f = 2.5GHz-4GHz		-59 -37 -27 -21		dB
DDRL ⁽²⁾	Differential Return Loss	f = 100MHz f = 100MHz-1.25GHz f = 1.25GHz-2.5GHz f = 2.5GHz-4GHz		-27 -23.3 -23.3 -13.5		dB
DDNEXT ^(2,3)	Near End Crosstalk	f = 100MHz f = 100MHz-1.25GHz f = 1.25GHz-2.5GHz f = 2.5GHz-4GHz		-57 -38 -33 -32		dB
BW	-3dB Bandwidth			8.1		GHz

Notes:

- Guaranteed by design. Typical values are at V_{DD} = 3.3V, T_A = 25°C ambient and maximum loading.
- S parameters are measured with our evaluation board made with Rogers (R04350) material. Trace width is 30 mil, length 540 mil, trace impedance is 50 Ohm (+/5%) and total insertion loss of the trace is 0.5dB@4GHz.
- Measurement done with fixture deembedding.

PI3PCIE3212

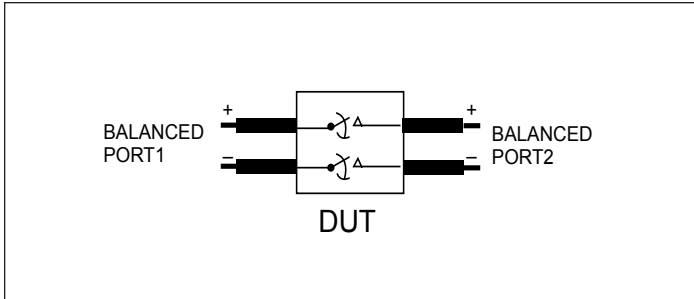

Diff. Insertion Loss and Return Test Circuit

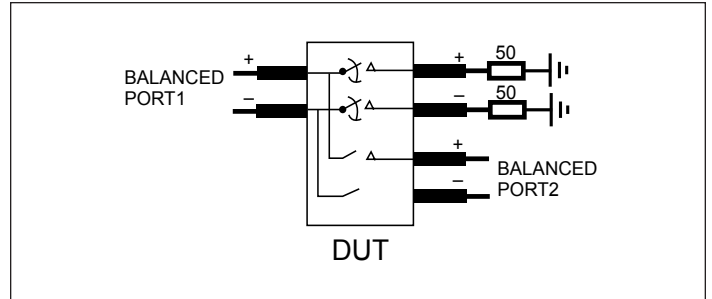

Diff. Off Isolation Test Circuit

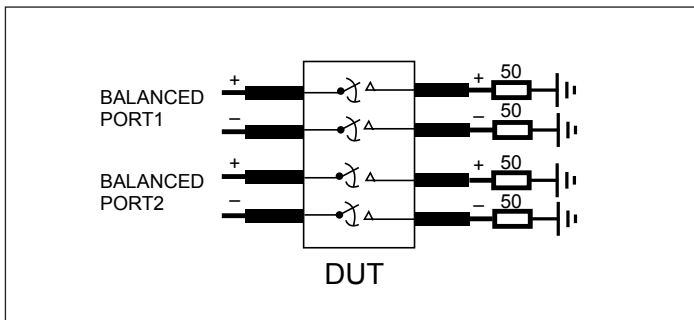

Diff. Near End Xtalk Test Circuit

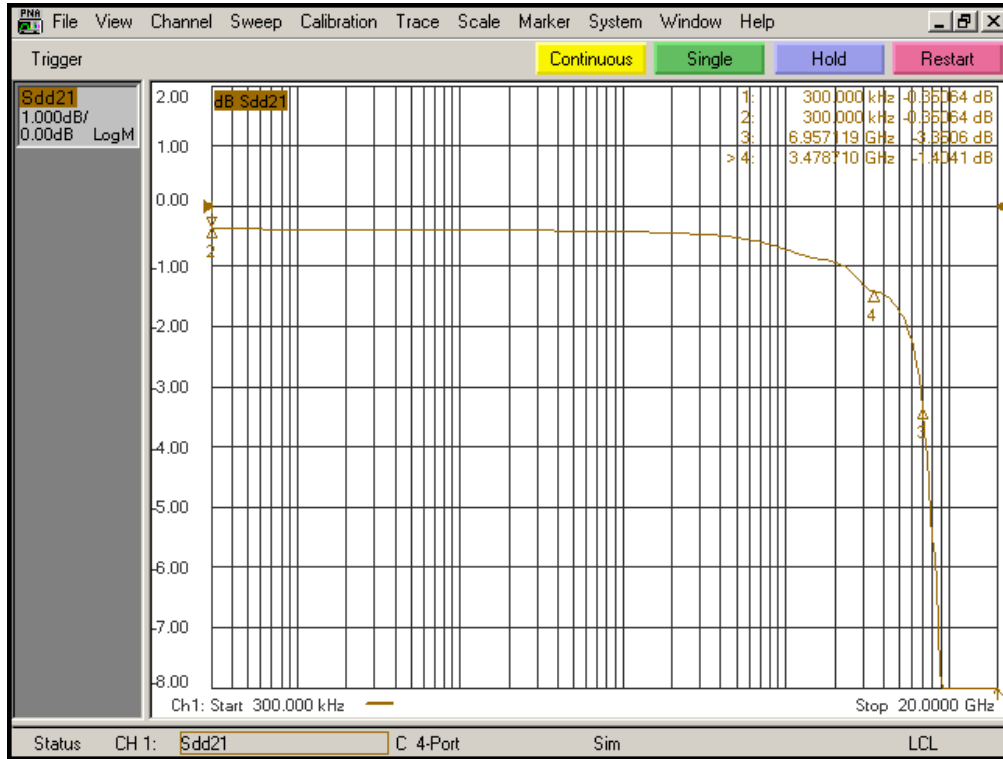

Differential Insertion Loss

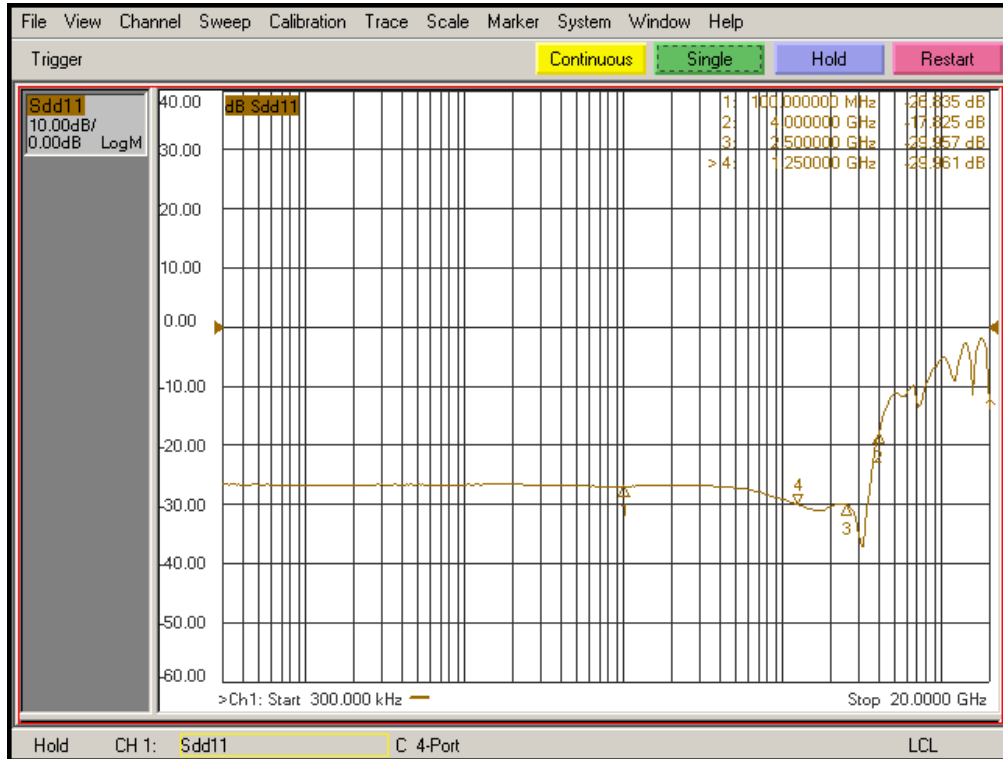

Differential Return Loss

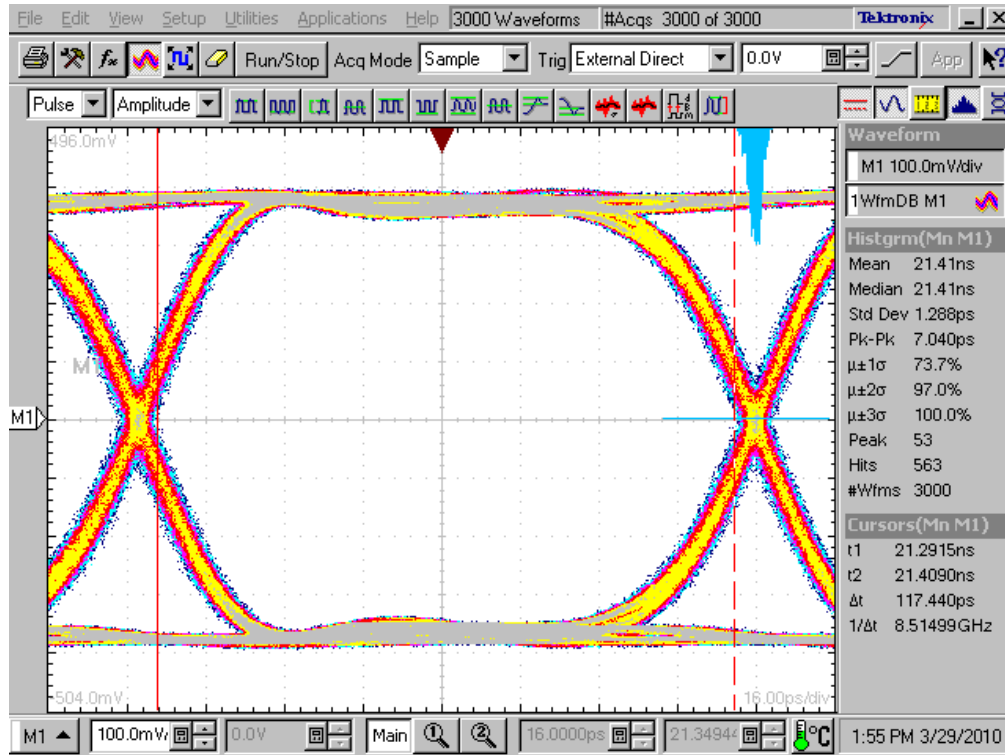

Differential Off Isolation

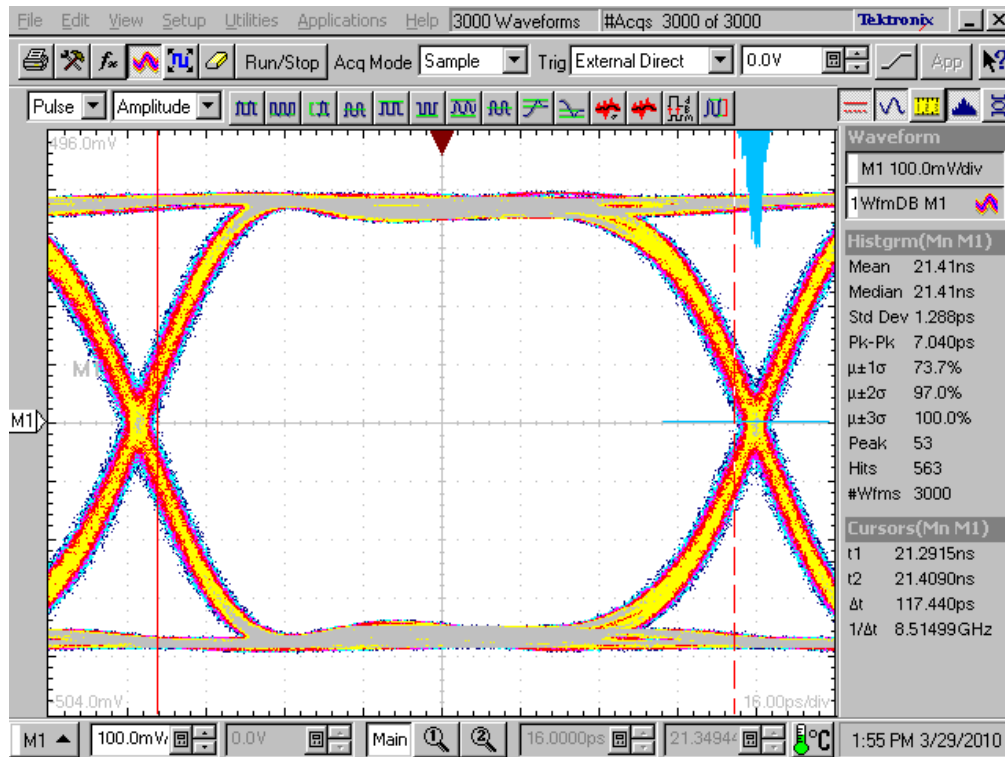

Differential Crosstalk

Test Circuit for Electrical Characteristics⁽¹⁻⁵⁾

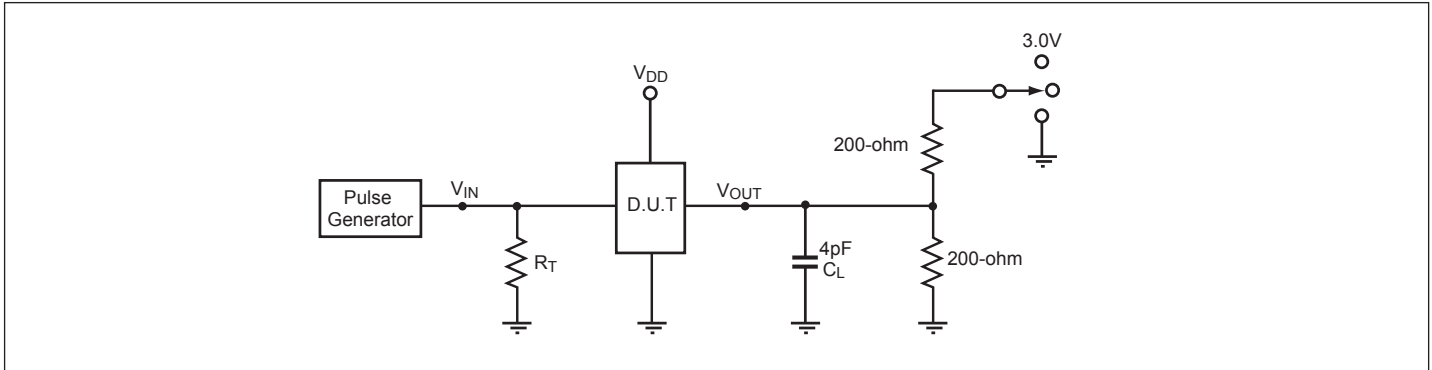

Notes:

1. C_L = Load capacitance: includes jig and probe capacitance.
2. R_T = Termination resistance: should be equal to Z_{OUT} of the Pulse Generator
3. Output 1 is for an output with internal conditions such that the output is low except when disabled by the output control.
Output 2 is for an output with internal conditions such that the output is high except when disabled by the output control.
4. All input impulses are supplied by generators having the following characteristics: $PRR \leq \text{MHz}$, $Z_O = 50\Omega$, $t_R \leq 2.5\text{ns}$, $t_F \leq 2.5\text{ns}$.
5. The outputs are measured one at a time with one transition per measurement.

Switch Positions

Test	Switch
t_{PLZ} , t_{PZL}	3.0V
t_{PHZ} , t_{PZH}	GND

Switching Waveforms

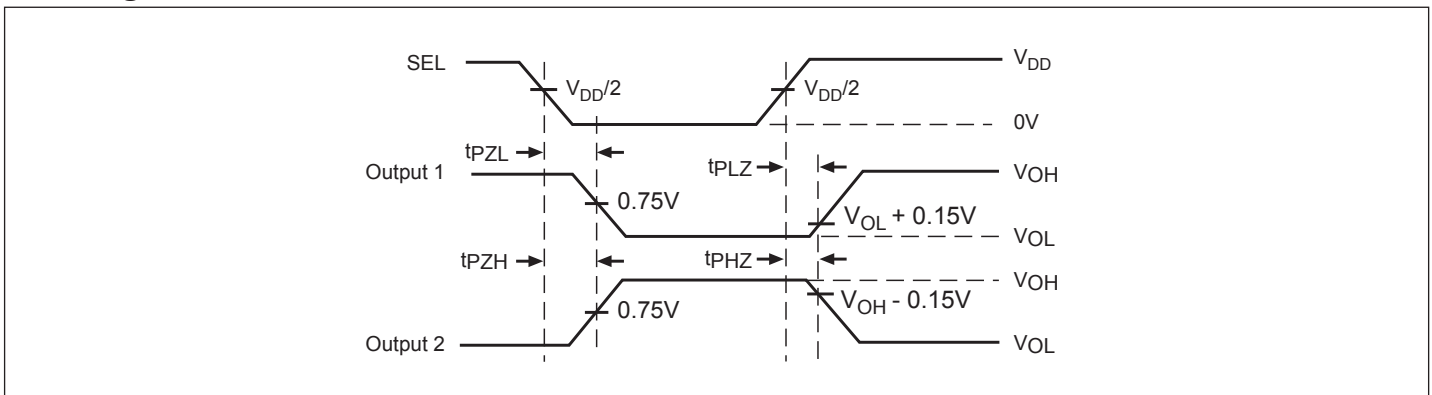

Voltage Waveforms Enable and Disable Times

Test Circuit for Propagation Delay

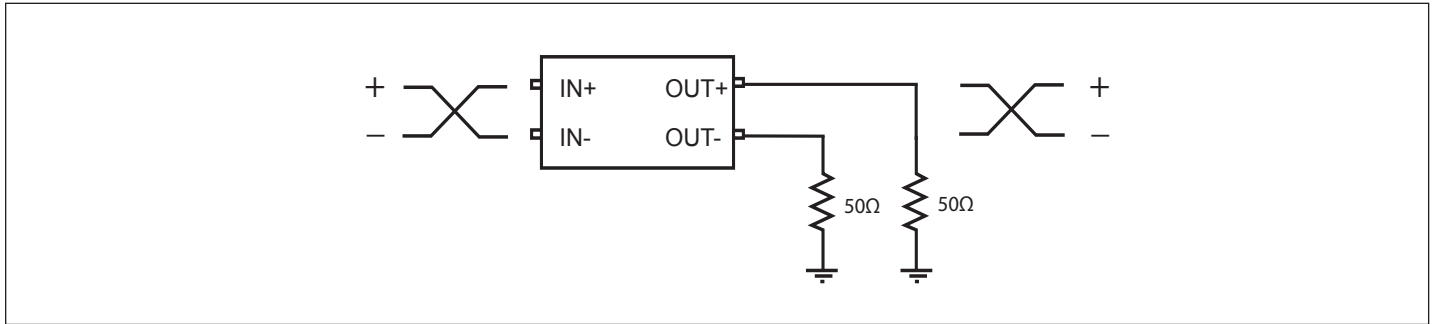

Differential Input/Output Signal Waveform

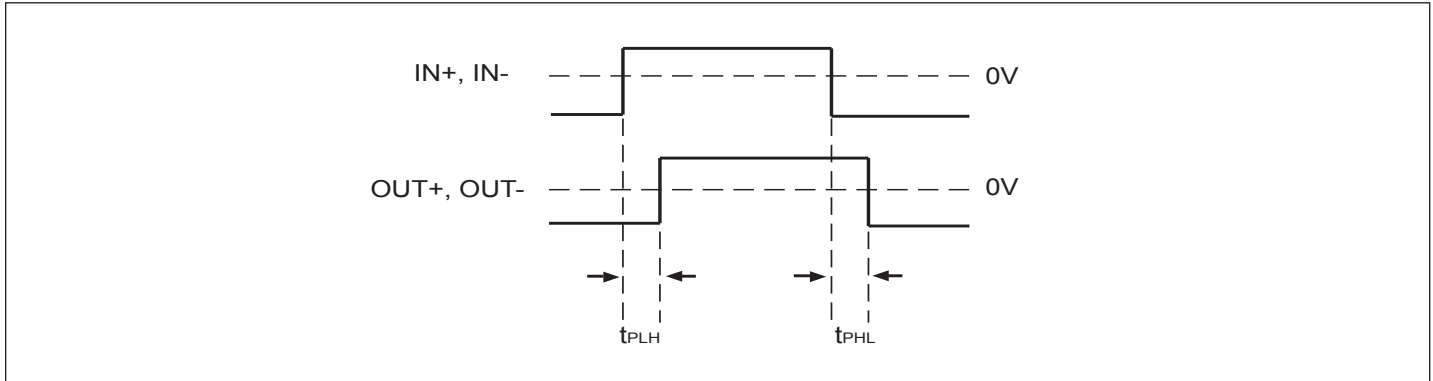

Part Marking

ZB Package

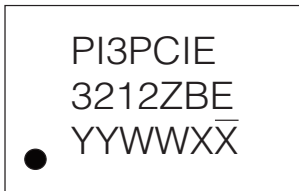

YY: Year
WW: Workweek
1st X: Assembly Code
2nd X: Fab Code

XUA Package

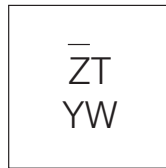

ZT: PI3PCIE3212
Y: Year
W: Workweek

Packaging Mechanical: 20-TQFN (ZB)

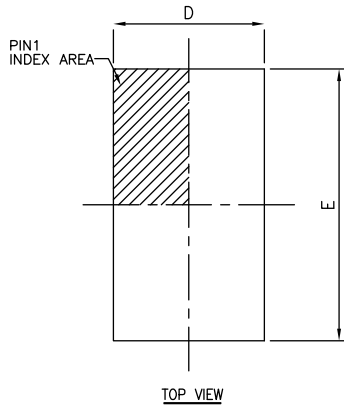

TOP VIEW

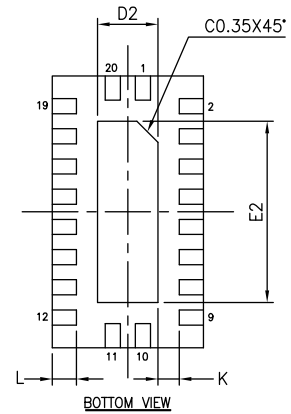
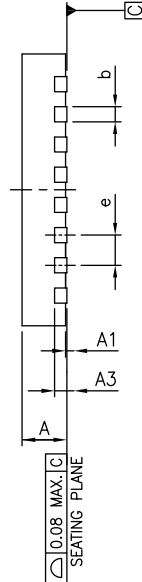

BOTTOM VIEW

SYMBOLS	MIN.	NOM.	MAX.
A	--	--	1.00
A1	0.00	0.02	0.05
A3	0.20 REF.		
b	0.18	0.25	0.30
D	2.40	2.50	2.60
E	4.40	4.50	4.60
e	0.50 BSC		
L	0.30	0.40	0.50
K	0.20	--	--
D2	0.90	1.00	1.10
E2	2.90	3.00	3.10

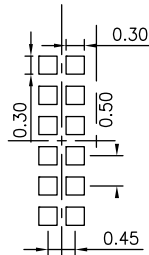

RECOMMENDED STENCIL DESIGN for EPAD
(0.125mm THICK STENCIL)

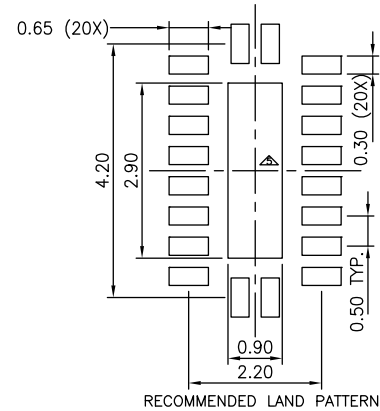

RECOMMENDED LAND PATTERN

NOTE :

1. ALL DIMENSIONS ARE IN mm. ANGLES IN DEGREES.
2. COPLANARITY APPLIES TO THE EXPOSED THERMAL PAD AS WELL AS THE TERMINALS.
3. REFER JEDEC MO-241
4. RECOMMENDED LAND PATTERN IS FOR REFERENCE ONLY.
5. THERMAL PAD SOLDERING AREA (MESH STENCIL DESIGN IS RECOMMENDED).

14-0265



DATE: 10/20/14

DESCRIPTION: 20-Contact, Very Thin Quad Flat No-Lead (TQFN)

PACKAGE CODE: ZB (ZB20)

DOCUMENT CONTROL #: PD-2104

REVISION: B

Packaging Mechanical: 18-XUA (X2QFN)

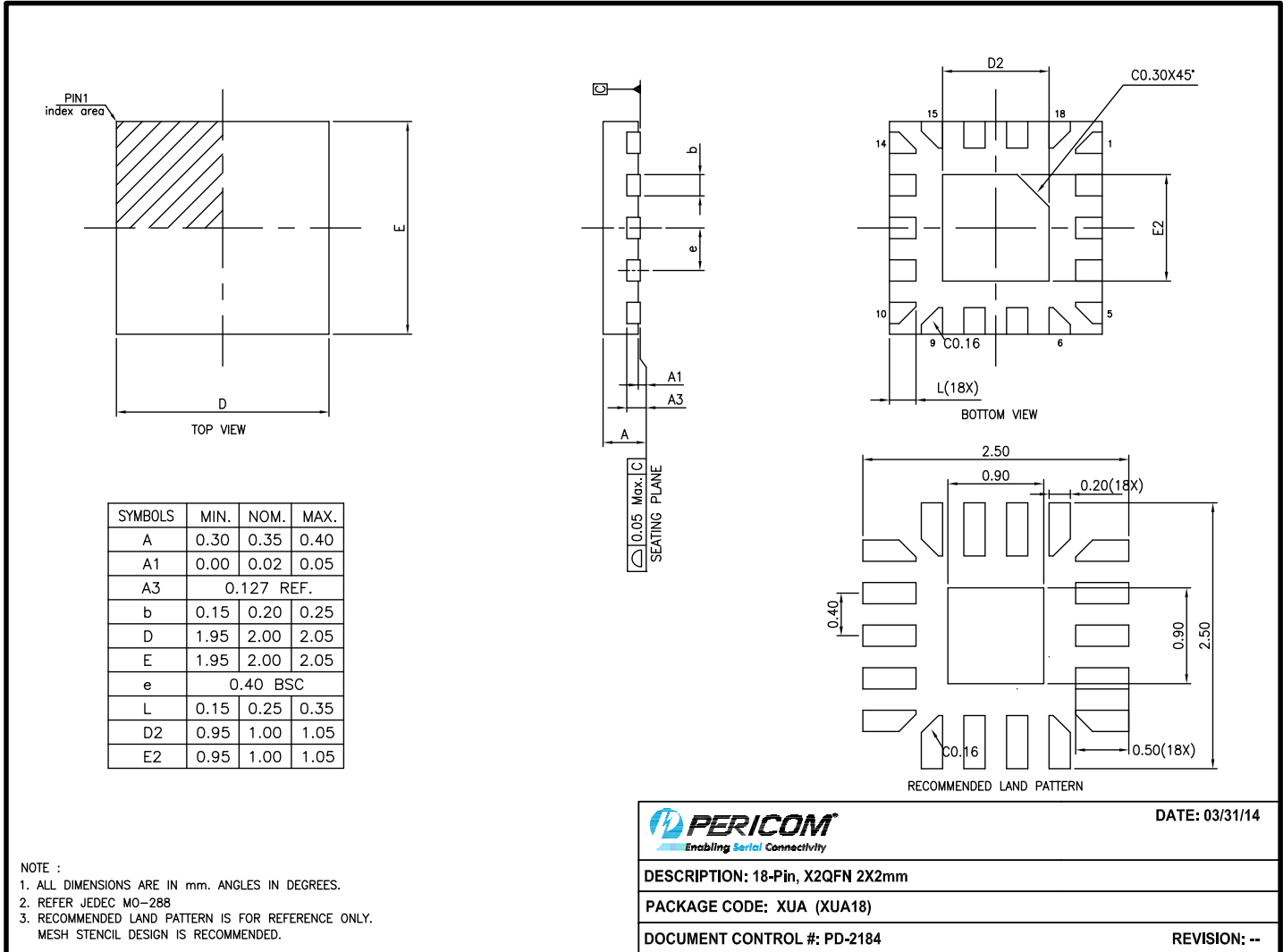

14-0039

For latest package info.

please check: <http://www.diodes.com/design/support/packaging/pericom-packaging/packaging-mechanicals-and-thermal-characteristics/>

Ordering Information

Ordering Code	Package Code	Package Type
PI3PCIE3212ZBEX	ZB	20-contact, Very Thin Quad Flat No-Lead (TQFN)
PI3PCIE3212XUAEX	XUA	18-Pin, 2x2mm (X2QFN)

Notes:

1. No purposely added lead. Fully EU Directive 2002/95/EC (RoHS), 2011/65/EU (RoHS 2) & 2015/863/EU (RoHS 3) compliant.
2. See <https://www.diodes.com/quality/lead-free/> for more information about Diodes Incorporated's definitions of Halogen- and Antimony-free, "Green" and Lead-free.
3. Halogen- and Antimony-free "Green" products are defined as those which contain <900ppm bromine, <900ppm chlorine (<1500ppm total Br + Cl) and <1000ppm antimony compounds.
4. E = Pb-free and Green
5. X suffix = Tape/Reel

IMPORTANT NOTICE

DIODES INCORPORATED MAKES NO WARRANTY OF ANY KIND, EXPRESS OR IMPLIED, WITH REGARDS TO THIS DOCUMENT, INCLUDING, BUT NOT LIMITED TO, THE IMPLIED WARRANTIES OF MERCHANTABILITY AND FITNESS FOR A PARTICULAR PURPOSE (AND THEIR EQUIVALENTS UNDER THE LAWS OF ANY JURISDICTION).

Diodes Incorporated and its subsidiaries reserve the right to make modifications, enhancements, improvements, corrections or other changes without further notice to this document and any product described herein. Diodes Incorporated does not assume any liability arising out of the application or use of this document or any product described herein; neither does Diodes Incorporated convey any license under its patent or trademark rights, nor the rights of others. Any Customer or user of this document or products described herein in such applications shall assume all risks of such use and will agree to hold Diodes Incorporated and all the companies whose products are represented on Diodes Incorporated website, harmless against all damages.

Diodes Incorporated does not warrant or accept any liability whatsoever in respect of any products purchased through unauthorized sales channel.

Should Customers purchase or use Diodes Incorporated products for any unintended or unauthorized application, Customers shall indemnify and hold Diodes Incorporated and its representatives harmless against all claims, damages, expenses, and attorney fees arising out of, directly or indirectly, any claim of personal injury or death associated with such unintended or unauthorized application.

Products described herein may be covered by one or more United States, international or foreign patents pending. Product names and markings noted herein may also be covered by one or more United States, international or foreign trademarks.

This document is written in English but may be translated into multiple languages for reference. Only the English version of this document is the final and definitive format released by Diodes Incorporated.

LIFE SUPPORT

Diodes Incorporated products are specifically not authorized for use as critical components in life support devices or systems without the express written approval of the Chief Executive Officer of Diodes Incorporated. As used herein:

A. Life support devices or systems are devices or systems which:

1. are intended to implant into the body, or

2. support or sustain life and whose failure to perform when properly used in accordance with instructions for use provided in the labeling can be reasonably expected to result in significant injury to the user.

B. A critical component is any component in a life support device or system whose failure to perform can be reasonably expected to cause the failure of the life support device or to affect its safety or effectiveness.

Customers represent that they have all necessary expertise in the safety and regulatory ramifications of their life support devices or systems, and acknowledge and agree that they are solely responsible for all legal, regulatory and safety-related requirements concerning their products and any use of Diodes Incorporated products in such safety-critical, life support devices or systems, notwithstanding any devices- or systems-related information or support that may be provided by Diodes Incorporated. Further, Customers must fully indemnify Diodes Incorporated and its representatives against any damages arising out of the use of Diodes Incorporated products in such safety-critical, life support devices or systems.

Copyright © 2020, Diodes Incorporated

www.diodes.com

Looking for pricing, stock, or lifecycle information?

Click below to explore more details on WIN SOURCE:

 [View PI3PCIE3212XUAEX on WIN SOURCE](#)

 [Diodes Incorporated](#) Information

Optimize Your Supply Chain with WIN SOURCE Solutions

-  Global Sourcing Solution
-  Obsolete Management
-  Cost Control Management
-  Shortage Management
-  Alternative Solution
-  Excess Inventory Management