

3.2Gbps, 1:2 Port Switch, SATA2/SAS ReDriver™

Features

- Two 3.2Gbps differential signal
- Adjustable Receiver Equalization
- 100-Ohm Differential CML I/O's
- Independent output level control
- Input signal level detect and squelch for each channel
- OOB support
- Low Power (100mW per Channel)
- Stand-by Mode – Power Down State
- V_{DD} Operating Range: 1.5V to 1.8V
- Industrial Operating Temperature Range: -40°C to 85°C
- Packaging: — 28-TQFN (3.5x 5.5mm)

Description

Pericom Semiconductor's PI2EQX3421 is a low power, signal ReDriver. The device provides programmable equalization, to optimize performance over a variety of physical mediums by reducing Inter-Symbol Interference. PI2EQX3421 supports two 100-Ohm Differential CML data I/O's between the Protocol ASIC to a switch fabric, across a backplane, or to extend the signals across other distant data pathways on the user's platform.

The integrated equalization circuitry provides flexibility with signal integrity of the signal input to ReDriver.

A low-level input signal detection and output squelch function is provided for each channel. Each channel operates fully independently. When the channels are enabled (CE=1) and operating, that channels input signal level (on XIN+/-) determines whether the output is enabled. If the input signal level of the channel falls below the active threshold level (V_{th}-) then the outputs are driven to the common mode voltage.

In addition to signal conditioning, Pericom's PI2EQX3421 also provides power management Stand-by mode operated by the Chip Enable (CE) pin.

Block Diagram

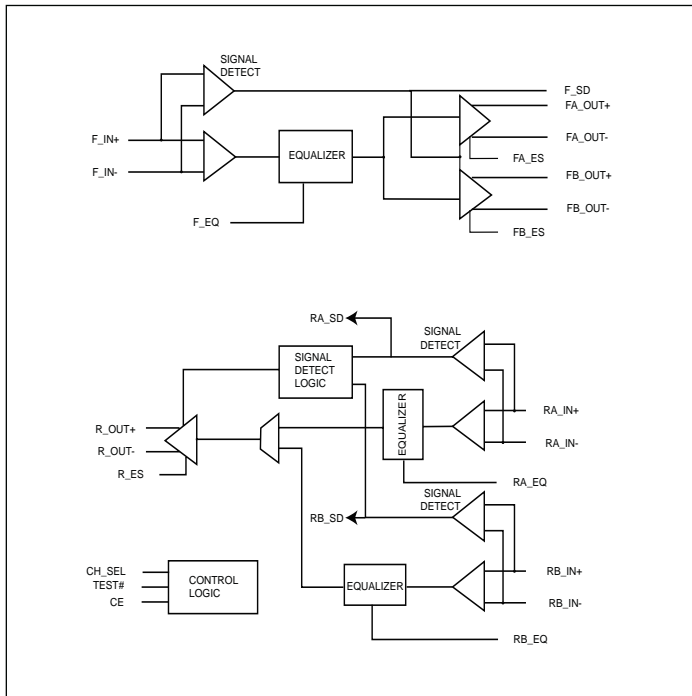

Pin Description (Top Side View)

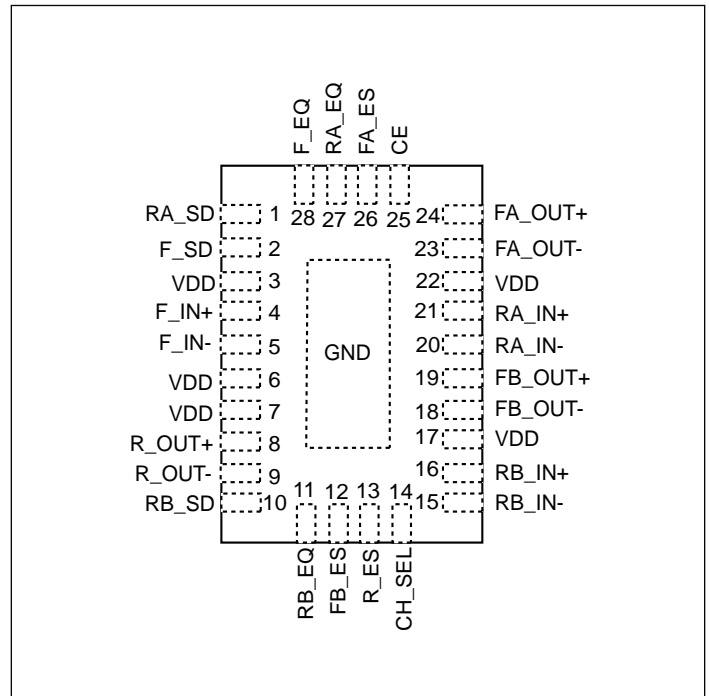

Pin Description

Pin #	Pin Name	Type	Description
25	CE	Input	Chip Enable "high" provides normal operation. "Low" for power down mode. With internal 50K-Ohm pull-up resistor.
14	CH_SEL	Input	Channel Select "high" selects path A. "Low" selects path B. With internal 50K-Ohm pull-up resistor.
28	F_EQ	Input	Selection pin for equalizer of Fin. "Low" means 2.5dB, "high" means 6.5dB. With internal 50K-Ohm pull-up resistor.
4 5	F_IN+ F_IN-	Input	CML input channel F with internal 50-Ohm pull down.
2	F_SD	Output	Channel Fin Signal detector output. Provides "high" when a signal is detected.
26	FA_ES	Input	"High" means FA_OUT operates to the SATA i/m standard. "Low" means FA_OUT support SATAx standard. With internal 50K-Ohm pull-up resistor.
24 23	FA_OUT+ FA_OUT-	Output	CML output channel FA with internal 50-Ohm pull up.
12	FB_ES	Input	"High" means FB_OUT operates to the SATA i/m standard. "Low" means FB_OUT support SATAx standard. With internal 50K-Ohm pull-up resistor.
19 18	FB_OUT+ FB_OUT-	Output	CML output channel FB with internal 50-Ohm pull up.
Center Pad	GND	GND	Supply ground.
13	R_ES	Input	"High" means Rout operates to the SATA i/m standard. "Low" means Rout support SATAx standard. With internal 50K-Ohm pull-up resistor.
27	RA_EQ	Input	Selection pin for equalizer of RA_IN. "Low" means 2.5dB, "high" means 6.5dB. With internal 50K-Ohm pull-up resistor.
21 20	RA_IN+ RA_IN-	Input	CML input channel RA with internal 50-Ohm pull down.
1	RA_SD	Output	Signal detector for Channel RA_IN. Provides "high" when signal is detected.
11	RB_EQ	Input	Selection pin for equalizer of RB_IN. "Low" means 2.5dB, "high" means 6.5dB. With internal 50K-Ohm pull-up resistor.
16 15	RB_IN+ RB_IN-	Input	CML input channel RB with internal 50-Ohm pull down.
10	RB_SD	Output	Signal detector for Channel RB_IN. Provides "high" when signal is detected.
8 9	R_OUT+ R_OUT-	Output	CML output channel R with internal 50-Ohm pull up.
3,6,7,17,22	VDD	Power	Positive Supply Voltage, 1.5V to 1.8V ($\pm 0.1V$)

Equalizer Selection

x_EQ	Compliance Channel @ 1.6 GHz
0	1.5dB ± 1.0dB
1	5.5dB ± 1.0dB

Output CML Buffer

CE	CH_SEL	X_ES	FA_OUT	FB_OUT	R_OUT
0	X	X	VDD	VDD	VDD
1	0	0	VDD	VDD-0.6V	VDD-0.6V
1	0	1	VDD	VDD-0.3V	VDD-0.3V
1	1	0	VDD-0.6V	VDD	VDD-0.6V
1	1	1	VDD-0.3V	VDD	VDD-0.3V

Maximum Ratings

(Above which useful life may be impaired. For user guidelines, not tested.)

Storage Temperature.....	-65°C to +150°C
Supply Voltage to Ground Potential.....	-0.5V to +2.5V
DC SIG Voltage	-0.5V to VDD +0.5V
Current Output	-25mA to +25mA
Power Dissipation Continuous	500mW
Operating Temperature	-40 to +85°C

Note:

Stresses greater than those listed under MAXIMUM RATINGS may cause permanent damage to the device. This is a stress rating only and functional operation of the device at these or any other conditions above those indicated in the operational sections of this specification is not implied. Exposure to absolute maximum rating conditions for extended periods may affect reliability.

AC/DC Electrical Characteristics (V_{DD} = 1.4V to 1.9V)

Symbol	Parameter	Conditions	Min.	Typ.	Max.	Units
P _{STANDBY}	Supply Power	CE = LVCMOS Low			1	mW
P _{ACTIVE}	Active Supply Power	CE = LVCMOS High			0.25	W
T _{pd}	Latency	Input to Output		1.0		ns
T _{SW}	Switch time, idle to active	CH_Sel toggles		50		ns
CML Receiver Input						
V _{RX-DIFFP-P}	Differential Input Peak-to-peak Voltage		0.200			V
V _{RX-CM-ACP}	AC Peak Common Mode Input Voltage				150	mV
Z _{RX-DC}	DC Input Impedance		40	50	60	Ohm
Z _{RX-DIFF-DC}	DC Differential Input Impedance		85	100	115	
Equalization						
J _{RS}	Residual Jitter ^(1,2)	Total Jitter			0.3	Ulp-p
J _{RM}	Random Jitter ^(1,2)			1.5		psrms
Signal Detector Performance						
V _{TH}	Threshold	CE = 1	65 ⁽³⁾		200 ⁽³⁾	mVppd
T _{EN}	Enable/disable time				16	ns

Notes

- K28.7 pattern is applied differentially at point A as shown in Figure 1.
- Total jitter does not include the signal source jitter. Total jitter (TJ) = (14.1 × RJ + DJ) where RJ is random RMS jitter and DJ is maximum deterministic jitter. Signal source is a K28.5 ± pattern (00 1111 1010 11 0000 0101) for the deterministic jitter test and K28.7 (0011111000) or equivalent for random jitter test. Residual jitter is that which remains after equalizing media-induced losses of the environment of Figure 1 or its equivalent. The deterministic jitter at point B must be from media-induced loss, and not from clock source modulation. Jitter is measured at 0V at point C of Figure 1.
- Using Compliance test at 1.5Gbps and 3Gbps. Also using OOB (OOB is formed by ALIGN_p primitive or D24.3) test patterns at 1.5Gbps. The ALIGN primitive (K28.5+D10.2+D27.3 = 0011111010+0101010101+0010011100). The D24.3 = 00110011001100110011

AC/DC Electrical Characteristics

Symbol	Parameter	Conditions	Min.	Typ.	Max.	Units
CML Transmitter Output (100-Ohm differential)						
$V_{TX-DIFFP-P}$	Differential Peak-to-peak Output Voltage ⁽¹⁾ $V_{TX-DIFFP-P} = 2 * V_{TX-D+} - V_{TX-D-} $	$x_{ES}=1$	400		750	mVppd
		$x_{ES}=0$	800		1300	
V_{TX-C}	Common-Mode Voltage ⁽¹⁾ $ V_{TX-D+} + V_{TX-D-} / 2$	$x_{ES}=1$		$V_{DD}-0.6$		mV
		$x_{ES}=0$		$V_{DD}-0.3$		
t_F, t_R	Transition Time	20% to 80%			150	ps
t_F-t_R / t_F+t_R	Transition Mismatch Time	20% to 80%			20	%
Z_{OUT}	Output resistance	Single ended		50		Ohm
$Z_{TX-DIFF-DC}$	DC Differential TX Impedance		80	100	120	Ohm
C_{TX}	AC Coupling Capacitor		0.3	4.7	12	nF
LVC MOS Control Pins						
V_{IH}	Input High Voltage		$0.65 \times V_{DD}$			V
V_{IL}	Input Low Voltage				$0.35 \times V_{DD}$	
I_{IH}	Input High Current				250	μA
I_{IL}	Input Low Current				500	
V_{OH}	DC Output Logic High	$I_{OH} = 4mA$	$V_{DD} - 0.45$			V
V_{OL}	DC Output Logic Low	$I_{OL} = 4mA$			0.4	

Note:

1. When $x_{ES}=0$, select SATAx standard. When $x_{ES}=1$, select SATAI/m standard.

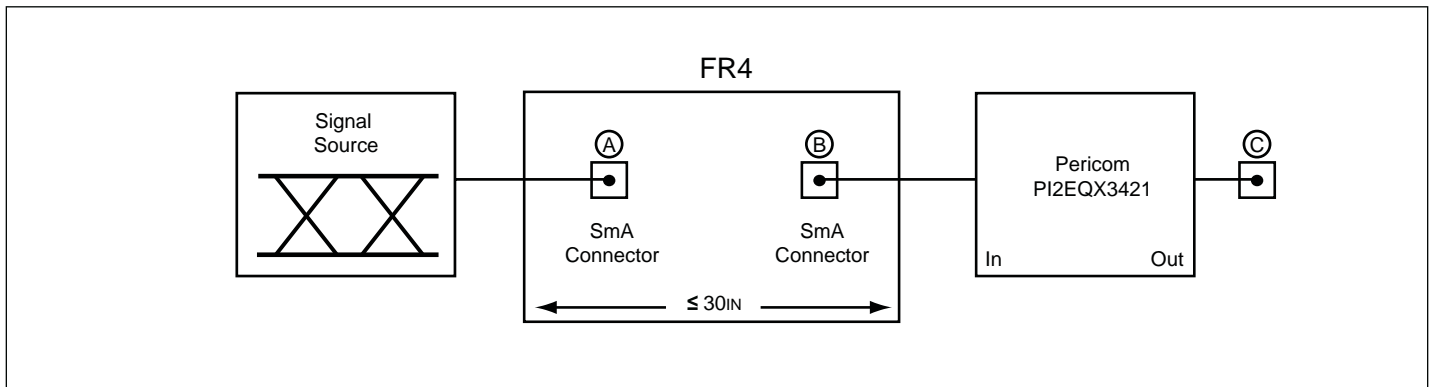
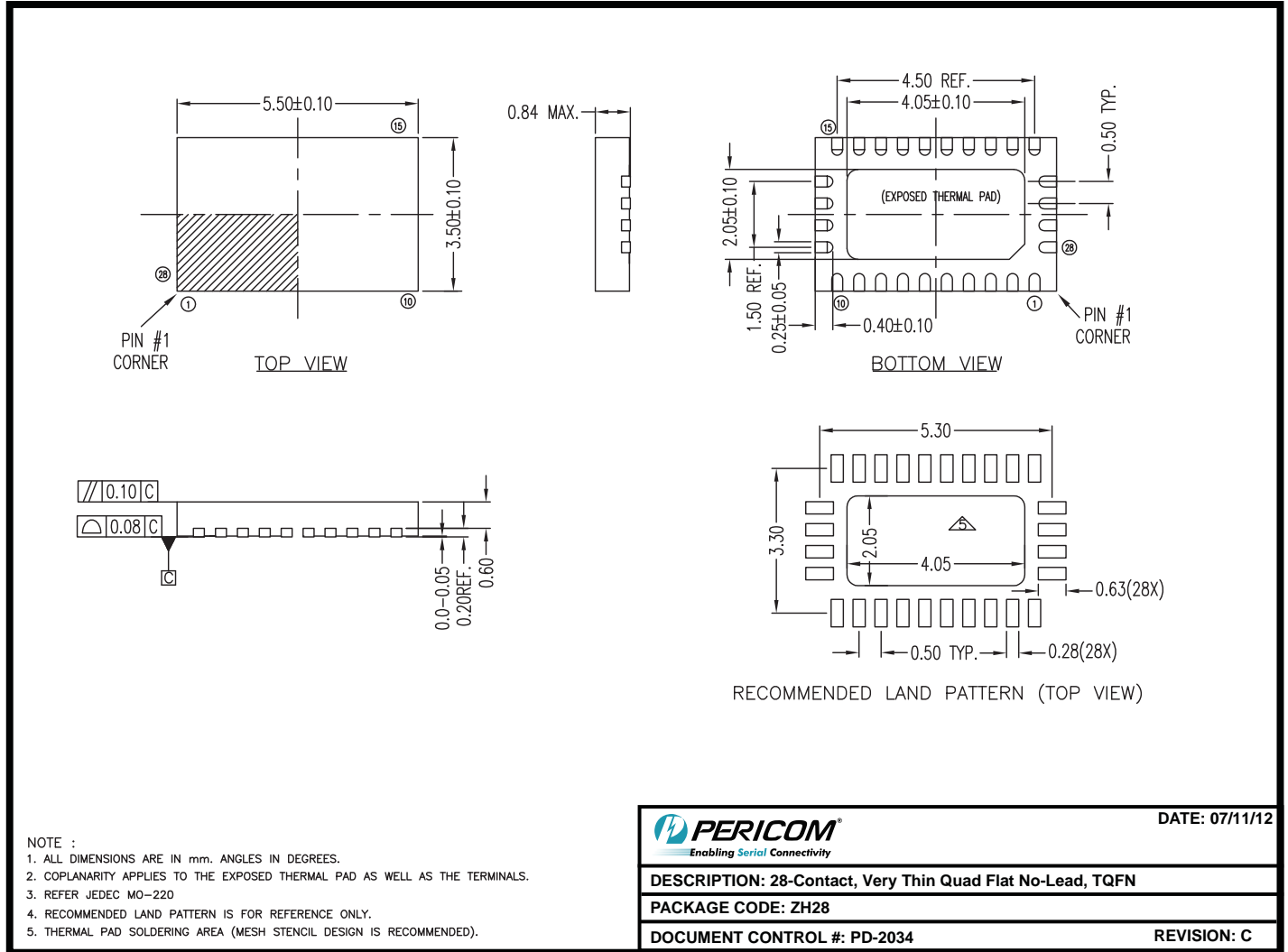

Figure 1. Test Condition Referenced in the Electrical Characteristic Table

Packaging Mechanical: 28-contact TQFN (ZH)



12-0419

Note: For latest package info, please check: <http://www.pericom.com/products/packaging/mechanicals.php>

Ordering Information

Ordering Number	Package Code	Package Description
PI2EQX3421ZHE	ZH	Pb-Free and Green 28-contact TQFN

Notes:

- Thermal characteristics can be found on the company web site at www.pericom.com/packaging/
- E = Pb-free and Green
- X suffix = Tape/Reel

Looking for pricing, stock, or lifecycle information?

Click below to explore more details on WIN SOURCE:

 [View PI2EQX3421ZHEX on WIN SOURCE](#)

 [Diodes Incorporated](#) Information

Optimize Your Supply Chain with WIN SOURCE Solutions

-  Global Sourcing Solution
-  Obsolete Management
-  Cost Control Management
-  Shortage Management
-  Alternative Solution
-  Excess Inventory Management