



**THE DATASHEET OF
PCA8530DUG/DAZ**





PCA8530

Automotive 102 x 4 Chip-On-Glass LCD segment driver

Rev. 2 — 25 September 2014

Product data sheet

1. General description

The PCA8530 is a fully featured Chip-On-Glass (COG)¹ Liquid Crystal Display (LCD) driver, designed for high-contrast Vertical Alignment (VA) LCD with multiplex rates up to 1:4. It generates the drive signals for a static or multiplexed LCD containing up to 4 backplane, 102 segment outputs, and up to 408 segments/elements. The PCA8530 features an internal charge pump with internal capacitors for on-chip generation of the LCD driving voltage. To ensure an optimal and stable contrast over the full temperature range, the PCA8530 offers a programmable temperature compensation of the LCD supply voltage. The PCA8530 can be easily controlled by a microcontroller through either the two-line I²C-bus or a four-line bidirectional SPI-bus.

For a selection of NXP LCD segment drivers, see [Table 58 on page 93](#).

2. Features and benefits

- AEC Q100 grade 2 compliant for automotive applications
- Low power consumption
- Extended operating temperature range from –40 °C to +105 °C
- 102 segments and 4 backplanes allowing to drive:
 - ◆ up to 51 7-segment numeric characters
 - ◆ up to 25 14-segment alphanumeric characters
 - ◆ any graphics of up to 408 segments/elements
- 408-bit RAM for display data storage
- Two sets of backplane outputs providing higher flexibility for optimal COG layout configurations
- Up to 4 chips can be cascaded to drive larger displays with an internally generated or externally supplied V_{LCD}
- Selectable backplane drive configuration: static, 2, or 4 backplane multiplexing
- LCD supply voltage
 - ◆ Programmable internal charge pump for on-chip LCD voltage generation up to $5 \times V_{DD2}$
 - ◆ External LCD voltage supply possible as well
- Selectable 400 kHz I²C-bus or 3 MHz SPI-bus interface
- Selectable linear temperature compensation of V_{LCD}
- Selectable display bias configuration
- Wide range for digital and analog power supply: from 2.5 V to 5.5 V

1. The definition of the abbreviations and acronyms used in this data sheet can be found in [Section 21 on page 95](#).



- Wide LCD voltage range from 4.0 V for low threshold LCDs up to 12.0 V for high threshold twisted nematic and Vertical Alignment (VA) displays
- Display memory bank switching in static and 1:2 multiplex drive modes
- Programmable frame frequency in the range of 45 Hz to 300 Hz; factory calibrated with a tolerance of ± 3 Hz (at 80 Hz)
- Selectable inversion scheme for LCD driving waveforms: frame or n-line inversion
- Diagnostic features for status monitoring
- Integrated temperature sensor with temperature readout
- On chip calibration of internal oscillator frequency and V_{LCD}
- Laser marking at the back-side of the die for traceability of the lot number, wafer number, and die position on the wafer

3. Applications

- Automotive
 - ◆ Instrument clusters
 - ◆ Climate control
 - ◆ Car entertainment
 - ◆ Car radio
- Industrial
 - ◆ Consumer
 - ◆ Medical and health care
 - ◆ Measuring equipment
 - ◆ Machine control systems
 - ◆ Information boards
 - ◆ White goods
 - ◆ General-purpose display modules

4. Ordering information

Table 1. Ordering information

Type number	Package		
	Name	Description	Version
PCA8530DUG	bare die	247 bumps	PCA8530DUG

4.1 Ordering options

Table 2. Ordering options

Product type number	Orderable part number	Sales item (12NC)	Delivery form	IC revision
PCA8530DUG/DA	PCA8530DUG/DAZ	935304675033	chips with bumps ^[1] in tray	1

[1] Bump hardness, see [Table 56 on page 90](#).

5. Marking

Table 3. Marking codes

Product type number	Marking code
PCA8530DUG/DA	on the active side of the die PC8530-1 on the rear side of the die ^[1] LLLLLL WW XXXXXX

[1] The rear side marking has the following meaning:
LLLLLL — wafer lot number
WW — wafer number
XXXXXX — die identification number

6. Block diagram

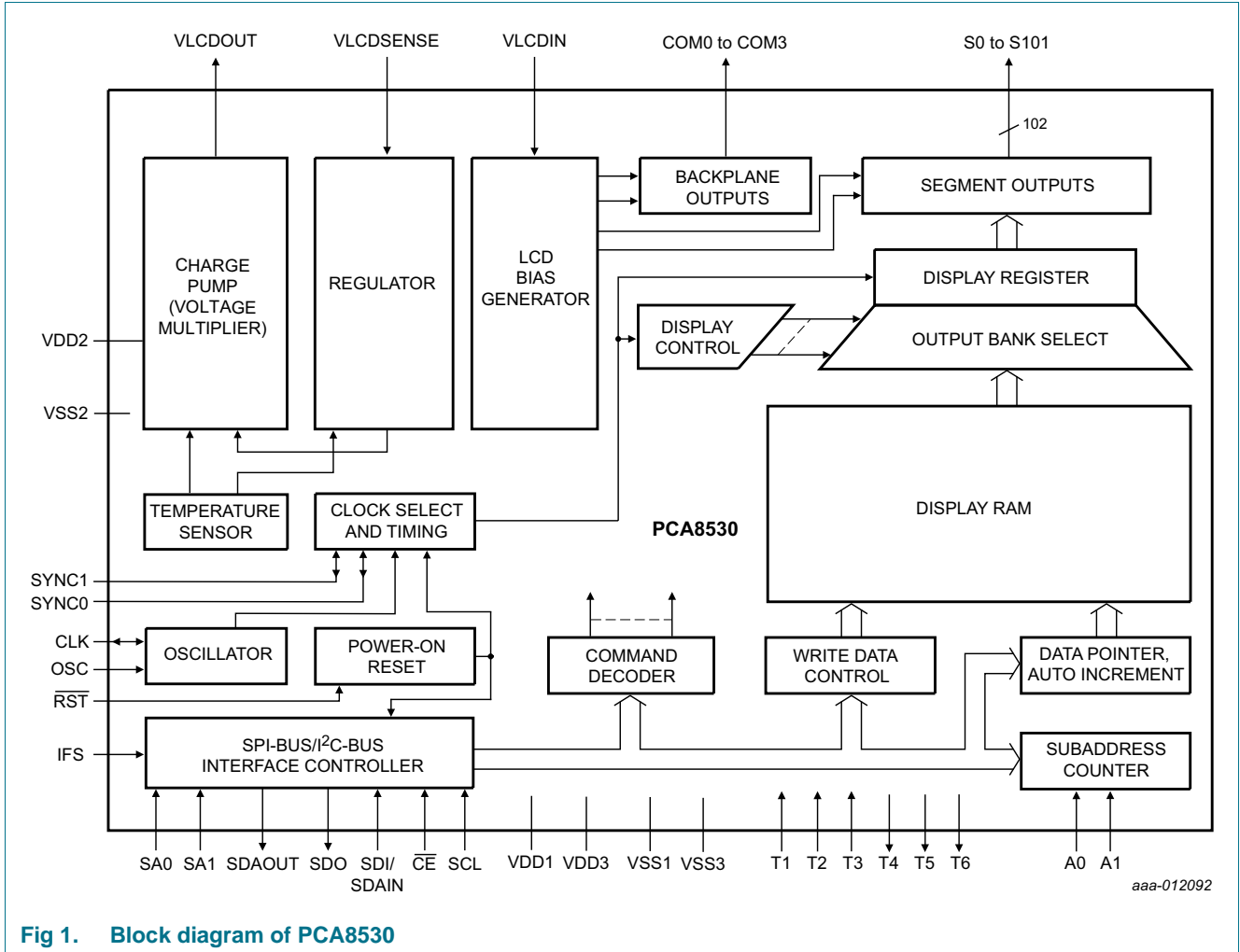
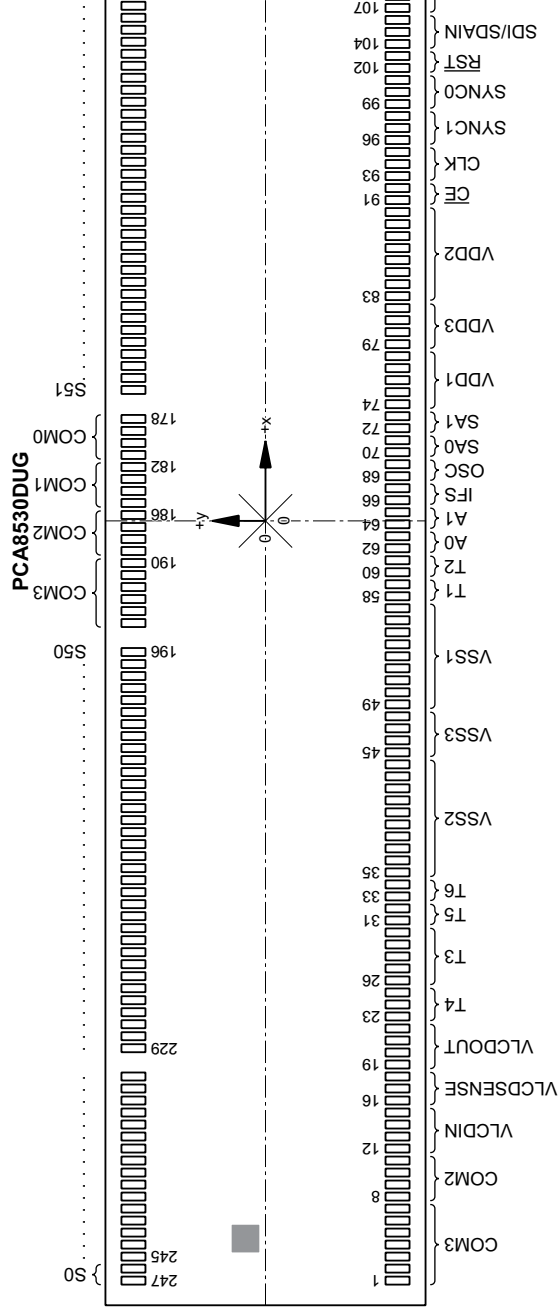

Fig 1. Block diagram of PCA8530

7. Pinning information

7.1 Pinning



Viewed from active side. For mechanical details, see [Figure 59 on page 85](#).

Fig 2. Pinning diagram of PCA8530DUG

7.2 Pin description

Table 4. Pin description

Input or input/output pins must always be at a defined level (V_{SS} or V_{DD}) unless otherwise specified.

Symbol	Pin	Type	Description
Backplane output pins			
COM3	1 to 7, 190 to 195	output	LCD backplane
COM2	8 to 11, 186 to 189		
COM1	117 to 120, 182 to 185		
COM0	121 to 125, 178 to 181		
Segment output pins			
S101	126, 127	output	LCD segment
S100 to S51	128 to 177		
S50 to S1	196 to 245		
S0	246, 247		
V_{LCD} pins			
VLCDIN	12 to 15	supply	V_{LCD} input
VLCDSENSE	16 to 18	input	V_{LCD} regulation input
VLCDOUT	19 to 22	output	V_{LCD} output
Test pins			
T4	23 to 25	output	not accessible; must be left open
T3	26 to 30	input	not accessible; must be connected to T5
T5	31, 32	output	not accessible; must be connected to T3
T6	33, 34	output	not accessible; must be left open
T1	58, 59	input	not accessible; must be connected to V_{SS1}
T2	60, 61		
Supply pins			
VSS2 ^[1]	35 to 44	supply	ground supply
VSS3 ^[1]	45 to 48		
VSS1 ^[1]	49 to 57		
VDD1	74 to 78	supply	supply voltage 1 (analog and digital)
VDD3	79 to 82	supply	supply voltage 3 (analog)
VDD2	83 to 90	supply	supply voltage 2 (charge pump)
Oscillator, synchronization, addressing, and reset pins			
CLK ^[2]	93 to 95	input/output	internal oscillator output, external oscillator input
OSC ^[2]	68, 69	input	clock (internal/external) selector
SYNC1 ^[3]	96 to 98	input/output	charge pump synchronization for cascaded devices; must not be connected if V_{LCD} is externally supplied
SYNC0 ^[3]	99 to 101	input/output	display synchronization for cascaded devices
\overline{RST}	102, 103	input	active LOW reset input
A0	62, 63	input	hardware device address selection for cascading; <ul style="list-style-type: none"> connect to V_{SS1} for logic 0 connect to V_{DD1} for logic 1
A1	64, 65	input	

Table 4. Pin description ...continued

Input or input/output pins must always be at a defined level (V_{SS} or V_{DD}) unless otherwise specified.

Symbol	Pin	Type	Description	
Bus-related pins				
			SPI-bus	I ² C-bus
IFS	66, 67	input	interface selector input	
			<ul style="list-style-type: none"> connect to V_{SS1} 	<ul style="list-style-type: none"> connect to V_{DD1}
SA0	70, 71	input	unused;	slave address selector;
SA1	72, 73	input	<ul style="list-style-type: none"> connect to V_{SS1} 	<ul style="list-style-type: none"> connect to V_{SS1} for logic 0 connect to V_{DD1} for logic 1
\overline{CE}	91, 92	input	chip enable input (active LOW)	unused;
				<ul style="list-style-type: none"> connect to V_{DD1}
SDI/SDAIN	104 to 106	input	SPI-bus data input	I ² C-bus serial data input
SDAOUT	107 to 111	output	unused;	serial data output
			<ul style="list-style-type: none"> must be connected to V_{SS1} 	
SDO	112, 113	output	SPI serial data output	unused;
				<ul style="list-style-type: none"> must be left open
SCL	114 to 116	input	serial clock input	serial clock input

- [1] The substrate (rear side of the die) is connected to V_{SS1} and should be electrically isolated.
- [2] If pin OSC is tied to V_{SS1} , CLK is the output pin of the internal oscillator. If pin OSC is tied to V_{DD1} , CLK is the input pin for the external oscillator.
- [3] If cascading is not used, pin must be left floating; for cascading see [Section 15.2 on page 80](#).

8. Functional description

8.1 Commands of PCA8530

The PCA8530 is controlled by the commands defined in [Table 5](#).

Remark: Any other combinations of operation code bits that are not mentioned in this document are operation modes of PCA8530.

Table 5. Commands of PCA8530

Command name	R/W[1]	Register selection RS[1:0][2]	Command bits							
			7	6	5	4	3	2	1	
General control commands										
Initialize	0	0	0	0	1	1	1	1	0	1
OTP-refresh	0	0	0	1	0	1	1	1	0	0
Device-address	0	0	0	0	0	1	1	1	0	A[1:0]
SYNC1_pin	0	0	0	1	0	1	1	1	0	0
Clock-out-ctrl	0	0	0	1	0	1	0	0	1	0
Read-select	0	0	0	0	0	1	1	1	1	0
Status-readout	1	0	0	TD[7:0]						
temperature device status				SR7	SR6	SR5	SR4	SR[3:0]		
Clear-reset-flag	0	0	0	0	0	0	1	1	1	1
Charge pump and LCD bias control commands										
Charge-pump-ctrl	0	0	0	1	1	0	0	CPE	CPC[2:0]	
Set-V _{LCD}	MSB	0	0	0	1	0	V[8:4]			
	LSB	0	0	0	1	1	0	V[3:0]		
Set-bias-mode	0	0	0	1	1	0	1	0	0	B[1:0]

Table 5. Commands of PCA8530 ... continued

Command name	R/W ^[1]	Register selection RS[1:0] ^[2]	Command bits							
			7	6	5	4	3	2	1	
Temperature compensation control commands										
Temperature-ctrl	0	1	0	0	0	0	0	0	TCE	TMF
TC-slope	A	1	0	0	0	0	0	1	TSA[2:0]	
	B	1	0	0	0	0	1	0	TSB[2:0]	
	C	1	0	0	0	0	1	1	TSC[2:0]	
	D	1	0	0	0	1	0	0	TSD[2:0]	
	E	1	0	0	0	1	0	1	TSE[2:0]	
	F	1	0	0	0	1	1	0	TSF[2:0]	
TC-set	1	1	0	0	1	1	1	1	T1T[2:0]	
	2	1	0	0	1	0	0	0	T2T[2:0]	
	3	1	0	0	1	0	0	1	T3T[2:0]	
	4	1	0	0	1	0	1	0	T4T[2:0]	
Display control commands										
Set-MUX-mode	0	0	0	0	0	0	0	0	M[2:0]	
Inversion-mode	0	0	0	1	0	0	1	0	INV[2:0]	
Display-ctrl	0	0	0	0	0	1	1	0	0	0
Clock and frame frequency command										
Frame-frequency	0	0	0	1	1	1	1	1	FF[4:0]	
Display RAM commands										
Write-display-data	0	0	1	DB[7:0]						
Input-bank-select	0	0	0	0	0	0	0	1	0	IB[1:0]
Output-bank-select	0	0	0	0	0	0	1	0	0	OB[1:0]
Data-pointer-init	0	0	0	1	0	1	0	0	0	0
Data-pointer	MSB	0	0	1	0	0	0	0	0	PX[6:4]
	LSB	0	0	1	0	0	1	0	1	PX[3:0]

[1] For further information about the R/W-bit, see [Table 42 on page 56](#).

[2] For further information about the register selection bits, see [Table 42 on page 56](#).

8.2 General control commands

8.2.1 Initialization

8.2.1.1 Command: Initialize

This command generates a chip-wide reset of the device without changing the content of the display RAM. For further information about start-up and shut-down, see [Section 8.8 on page 26](#).

Table 6. Initialize command bit description

Bit	Symbol	Value	Description
-	$\overline{R/W}$	0	fixed value
-	RS[1:0]	00	fixed value
7 to 0	-	00111010	fixed value

8.2.1.2 \overline{RST} pin

The \overline{RST} pin generates a chip-wide reset of the device without changing the content of the display RAM. For further information about start-up and shut-down, see [Section 8.8 on page 26](#).

8.2.2 Command: OTP-refresh

Each IC is calibrated during production and testing of the device in order to achieve the specified accuracy of the V_{LCD} , the frame frequency, and the temperature measurement. This calibration is performed on EPROM cells called One Time Programmable (OTP) cells. These cells are read by the device after a reset and every time when the Initialize command or the OTP-refresh command is sent. The OTP-refresh command takes approximately 10 ms to finish.

Table 7. OTP-refresh - OTP-refresh command bit description

Bit	Symbol	Value	Description
-	$\overline{R/W}$	0	fixed value
-	RS[1:0]	00	fixed value
7 to 0	-	11011000	fixed value

8.2.3 Command: Device-address

The Device-address command allows setting the address of the device in a cascaded configuration and corresponds with pins A0 and A1 (see [Section 15.2 on page 80](#)).

Table 8. Device-address - device address command bit description

Bit	Symbol	Value	Description
-	$\overline{R/W}$	0	fixed value
-	RS[1:0]	00	fixed value
7 to 2	-	000110	fixed value
1 to 0	A[1:0]		set address
		00	master
		01	slave 1
		10	slave 2
		11	slave 3

8.2.4 Command: SYNC1_pin

With the SYNC1_pin command, the SYNC1 pin can be configured for using the PCA8530 as a single chip or a master in a cascade. If the PCA8530 is a slave in a cascade, the command has no effect.

Table 9. SYNC1_pin - SYNC1 pin configuration command bit description

This command has no effect if the PCA8530 is a slave in a cascade.

Bit	Symbol	Value	Description
-	$\overline{R/W}$	0	fixed value
-	RS[1:0]	00	fixed value
7 to 1	-	1011100	fixed value
0	OE		SYNC1 pin configuration
		0	pin SYNC1 is an output; gated to 0 V; to be used when PCA8530 is a single chip
		1	pin SYNC1 is an output; providing the synchronization signal; to be used when PCA8530 is a master in a cascade

8.2.5 Command: Clock-out-ctrl

When pin CLK is configured as an output pin, the Clock-out-ctrl command enables or disables the clock output on pin CLK ([Section 8.6.1 on page 22](#)).

Table 10. Clock-out-ctrl - CLK pin input/output switch command bit description

Bit	Symbol	Value	Description
-	$\overline{R/W}$	0	fixed value
-	RS[1:0]	00	fixed value
7 to 1	-	1101010	fixed value
0	COE		control pin CLK
		0	clock signal not available on pin CLK; pin CLK is in 3-state
		1	clock signal available on pin CLK

8.2.6 Command: Read-select

The Read-select command allows choosing to readout the temperature or the device status.

Table 11. Read-select - status read select command bit description

Bit	Symbol	Value	Description
-	$\overline{R/W}$	0	fixed value
-	RS[1:0]	00	fixed value
7 to 1	-	0001110	fixed value
0	SO		readout
		0	temperature; the Status-readout command allows to readout the temperature TD[7:0], see Table 12
		1	device status: the Status-readout command allows to readout some information about the status of the device, see Table 12

8.2.7 Command: Status-readout

The Status-readout command offers to readout some status bits of the PCA8530. These bits indicate the status of the device at the moment of reading.

Table 12. Status-readout - status and temperature read command bit description

For this command, bit R/W has to be set logic 1.

Bit	Symbol	Value	Description
-	R/W	1	fixed value
-	RS[1:0]	00	fixed value
Temperature readout if SO = 0 (see Table 11)			
7 to 0	TD[7:0]	00000000 to 11111111	temperature readout (see Section 8.10.4.1 on page 40)
Device status readout if SO = 1 (see Table 11)			
7	SR7		display status (see Table 22 on page 21)
		0	display is disabled
		1	display is enabled
6	SR6		charge pump switching status (status of bit CPE, see Table 14 on page 15)
		0	charge pump disabled
		1	charge pump enabled
5	SR5		charge pump charge status
		0	charge pump has not reached programmed value
		1	charge pump has reached programmed value
4	SR4		reset status flag
		0	no reset has occurred since the reset status flag was cleared last time
		1	reset has occurred since the reset status flag was cleared last time ^[1]
3 to 0	SR[3:0]		EMC detection
		01SA1SA0	pre-defined code for EMC detection when I ² C interface is used
		0101	pre-defined code for EMC detection when SPI interface is used

[1] The flag is set whenever a reset occurs, induced by $\overline{\text{RST}}$ pin, Power-On Reset (POR), or Initialize command. After power-on, the flag is set and should be cleared for reset monitoring.

Some bits of the Status-readout command have a certain probability of being changed by an EMC/ESD event. For example, an EMC/ESD event can cause a change of the hard-wired settings of SA1 or SA0. Therefore SR[3:0] can help to detect if an EMC/ESD event has occurred which has caused the change of a bit. In environments where EMC/ESD events may occur, it could be helpful to compare the result of the Status-readout command with the initial bit settings periodically.

8.2.8 Command: Clear-reset-flag

The Clear-reset-flag command clears the reset flag SR4, see [Table 12](#).

Table 13. Clear-reset-flag - Clear-reset-flag command bit description

Bit	Symbol	Value	Description
-	$\overline{R/W}$	0	fixed value
-	RS[1:0]	00	fixed value
7 to 0	-	00011111	fixed value

8.3 Charge pump and LCD bias control commands

8.3.1 Command: Charge-pump-ctrl

The Charge-pump-ctrl command enables or disables the internal V_{LCD} generation and controls the charge pump voltage multiplier settings.

Table 14. Charge-pump-ctrl - charge pump control command bit description

Bit	Symbol	Value	Description
-	$\overline{R/W}$	0	fixed value
-	RS[1:0]	00	fixed value
7 to 4	-	1100	fixed value
3	CPE		charge pump status
		0	charge pump disabled; no internal V_{LCD} generation; external supply of V_{LCD}
		1	charge pump enabled; internal V_{LCD} generation; no external supply of V_{LCD}
2 to 0	CPC[2:0]		charge pump voltage multiplier setting
		000	$V_{LCD} = 2 \times V_{DD2}$
		001	$V_{LCD} = 3 \times V_{DD2}$
		010	$V_{LCD} = 4 \times V_{DD2}$
		011	$V_{LCD} = 5 \times V_{DD2}$
		100 to 111	$V_{LCD} = V_{DD2}$ (direct mode)

8.3.2 Command: Set- V_{LCD}

The Set- V_{LCD} command allows setting the LCD voltage.

Table 15. Set- V_{LCD} - Set- V_{LCD} command bit description

Bit	Symbol	Value	Description
Set-V_{LCD}-MSB			
-	$\overline{R/W}$	0	fixed value
-	RS[1:0]	00	fixed value
7 to 5	-	010	fixed value
4 to 0	V[8:4]		set V_{LCD} MSB
		00000 to 11111	the 5 most significant bits of V[8:0]
Set-V_{LCD}-LSB			
-	$\overline{R/W}$	0	fixed value
-	RS[1:0]	00	fixed value
7 to 4	-	0110	fixed value
3 to 0	V[3:0]		set V_{LCD} LSB
		0000 to 1111	the 4 least significant bits of V[8:0]

A value of 0h corresponds to $V_{LCD} = 4$ V and values equal or higher than 10Ch correspond to $V_{LCD} = 12$ V without temperature compensation. Every LSB change corresponds to a V_{LCD} programming step of 0.03 V. For further information, see

[Section 8.10.3 on page 34](#) and [Equation 2 on page 35](#).

8.3.3 Command: Set-bias-mode

Table 16. Set-bias-mode - set bias mode command bit description

This command is not applicable for the static drive mode.

Bit	Symbol	Value	Description
-	$\overline{R/W}$	0	fixed value
-	RS[1:0]	00	fixed value
7 to 2	-	110100	fixed value
1 to 0	B[1:0]		set bias mode
		00, 01	unused
		11	$\frac{1}{3}$ bias
		10	$\frac{1}{2}$ bias

8.4 Temperature compensation control commands

8.4.1 Command: Temperature-ctrl

The Temperature-ctrl command enables or disables the temperature measurement block and the temperature compensation of V_{LCD} (see [Section 8.10.4 on page 40](#)).

Table 17. Temperature-ctrl - temperature measurement control command bit description

For this command, the register selection bits have to be set $RS[1:0] = 10$.

Bit	Symbol	Value	Description
-	$\overline{R/W}$	0	fixed value
-	RS[1:0]	10	fixed value
7 to 3	-	00000	fixed value
2	TCE		temperature compensation control
		0	temperature compensation of V_{LCD} disabled
		1	temperature compensation of V_{LCD} enabled
1	TMF		temperature measurement filter
		0	digital temperature filter disabled ^[1]
		1	digital temperature filter enabled
0	TME		temperature measurement control
		0	temperature measurement disabled; no temperature readout possible
		1	temperature measurement enabled; temperature readout possible

[1] The unfiltered digital value of TD[7:0] is immediately available for the readout and V_{LCD} compensation.

8.4.2 Command: TC-set

The TC-set command allows defining six temperature intervals in the operating temperature range from $-40\text{ }^{\circ}\text{C}$ to $+105\text{ }^{\circ}\text{C}$. For each of the temperature intervals, the TC-slope command (see [Section 8.4.3](#)) allows setting the temperature coefficient of V_{LCD} .

Table 18. TC-set - V_{LCD} temperature compensation set command bit description

For this command, the register selection bits have to be set $RS[1:0] = 10$.

Bit	Symbol	Value	Description
TC-set-1			
-	R/\overline{W}	0	fixed value
-	RS[1:0]	10	fixed value
7 to 3	-	00111	fixed value
2 to 0	T1T[2:0]	000 to 111	see Table 32 on page 42
TC-set-2			
-	R/\overline{W}	0	fixed value
-	RS[1:0]	10	fixed value
7 to 3	-	01000	fixed value
2 to 0	T2T[2:0]	000 to 111	see Table 32 on page 42
TC-set-3			
-	R/\overline{W}	0	fixed value
-	RS[1:0]	10	fixed value
7 to 3	-	01001	fixed value
2 to 0	T3T[2:0]	000 to 111	see Table 32 on page 42
TC-set-4			
-	R/\overline{W}	0	fixed value
-	RS[1:0]	10	fixed value
7 to 3	-	01010	fixed value
2 to 0	T4T[2:0]	000 to 111	see Table 32 on page 42

8.4.3 Command: TC-slope

The TC-slope command allows setting the temperature coefficients of V_{LCD} corresponding to six temperature intervals defined by the TC-set command.

Table 19. TC-slope - V_{LCD} temperature compensation slope command bit description

For this command, the register selection bits have to be set $RS[1:0] = 10$.

Bit	Symbol	Value	Description
TC-slope-A			
-	R/\overline{W}	0	fixed value
-	RS[1:0]	10	fixed value
7 to 3	-	00001	fixed value
2 to 0	TSA[2:0]	000 to 111	see Table 33 on page 43
TC-slope-B			
-	R/\overline{W}	0	fixed value
-	RS[1:0]	10	fixed value
7 to 3	-	00010	fixed value
2 to 0	TSB[2:0]	000 to 111	see Table 33 on page 43
TC-slope-C			
-	R/\overline{W}	0	fixed value
-	RS[1:0]	10	fixed value
7 to 3	-	00011	fixed value
2 to 0	TSC[2:0]	000 to 111	see Table 33 on page 43
TC-slope-D			
-	R/\overline{W}	0	fixed value
-	RS[1:0]	10	fixed value
7 to 3	-	00100	fixed value
2 to 0	TSD[2:0]	000 to 111	see Table 33 on page 43
TC-slope-E			
-	R/\overline{W}	0	fixed value
-	RS[1:0]	10	fixed value
7 to 3	-	00101	fixed value
2 to 0	TSE[2:0]	000 to 111	see Table 33 on page 43
TC-slope-F			
-	R/\overline{W}	0	fixed value
-	RS[1:0]	10	fixed value
7 to 3	-	00110	fixed value
2 to 0	TSF[2:0]	000 to 111	see Table 33 on page 43

8.5 Display control commands

8.5.1 Command: Set-MUX-mode

The Set-MUX-mode command allows setting the multiplex drive mode.

Table 20. Set-MUX-mode - set multiplex drive mode command bit description

Bit	Symbol	Value	Description
-	R/W	0	fixed value
-	RS[1:0]	00	fixed value
7 to 3	-	00000	fixed value
2 to 0	M[2:0]		set multiplex drive mode
		000 to 100	unused
		101	1:4 multiplex drive mode
		110	1:2 multiplex drive mode
		111	static

8.5.2 Command: Inversion-mode

The Inversion-mode command allows changing the drive scheme inversion mode.

The waveforms used to drive LCD displays (see [Figure 25 on page 46](#) to [Figure 28 on page 49](#)) inherently produce a DC voltage across the display cell. The PCA8530 compensates for the DC voltage by inverting the waveforms on alternate frames or alternate lines. The choice of the compensation method is determined with INV[2:0] in [Table 21](#).

Table 21. Inversion-mode - inversion mode command bit description

Bit	Symbol	Value	Description
-	R/W	0	fixed value
-	RS[1:0]	00	fixed value
7 to 3	-	10110	fixed value
2 to 0	INV[2:0]		set inversion mode
		000	frame inversion mode
		001	1-line inversion mode
		010	2-line inversion mode
		011	3-line inversion mode
		100 to 111	unused

8.5.2.1 Line inversion mode (driving scheme A)

In line inversion mode, the DC value is compensated every n^{th} line. Changing the inversion mode to line inversion mode reduces the possibility for flickering but increases the power consumption (see example waveforms in [Figure 25 on page 46](#) to [Figure 28 on page 49](#))

8.5.2.2 Frame inversion mode (driving scheme B)

In frame inversion mode, the DC value is compensated across two frames and not within one frame. Changing the inversion mode to frame inversion reduces the power consumption, therefore it is useful when power consumption is a key point in the application.

Frame inversion may not be suitable for all applications. The RMS voltage across a segment is better defined, however since the switching frequency is reduced there is possibility for flicker to occur.

8.5.3 Command: Display-ctrl

The Display-ctrl command enables or disables the display.

Table 22. Display-ctrl - display on and off switch command bit description

Bit	Symbol	Value	Description
-	R/\overline{W}	0	fixed value
-	RS[1:0]	00	fixed value
7 to 1	-	0011100	fixed value
0	DE		display control
		0	display disabled
		1	display enabled

8.6 Clock and frame frequency command

8.6.1 Oscillator

The internal logic and LCD drive signals of the PCA8530 are timed by the clock frequency f_{clk} , which is either internally generated by an on-chip oscillator circuit or externally supplied.

The clock frequency f_{clk} determines the internal data flow of the device that includes the transfer of display data from the display RAM to the display segment outputs and the generation of the LCD frame frequency.

8.6.2 External clock

When an external clock is used, the input pin OSC must be connected to V_{DD1} . The clock must be supplied to the CLK pin and must have an amplitude equal to the V_{DD1} voltage supplied to the chip and be referenced to V_{SS1} .

Remark: If an external clock is used, then this clock signal must always be supplied to the device. Removing the clock may freeze the LCD in a DC state, which is not suitable for the liquid crystal. Removal of the clock is possible when following the correct procedures as described in [Section 8.8.3 on page 29](#).

8.6.3 Internal clock

In applications where the internal clock is used, the input pin OSC must be connected to V_{SS1} . It is possible to make the clock frequency available on pin CLK by setting bit COE logic 1 (see [Table 10 on page 12](#)). If pin CLK is not used, it should be left open. At power-on the signal at pin CLK is disabled and pin CLK is in 3-state.

8.6.4 Command: Frame-frequency

With this command, the clock and frame frequency can be programmed when using the internal clock.

Table 23. Frame-frequency - frame frequency select command bit description

Bit	Symbol	Value	Description
-	$\overline{R/W}$	0	fixed value
-	RS[1:0]	00	fixed value
7 to 5	-	111	fixed value
4 to 0	FF[4:0]	see Table 24	clock and frame frequency (Hz)

The duty ratio of the clock output may change when choosing different values for the frame frequency (see [Table 24](#)).

The LCD frame frequency is derived from the clock frequency by a fixed division (see [Equation 1](#)).

$$f_{fr} = \frac{f_{clk}}{144} \tag{1}$$

The Frame-frequency command allows configuring the frame frequency in the range of 45 Hz to 300 Hz with steps of

- 5 Hz from 45 Hz to 100 Hz
- 10 Hz from 100 Hz to 300 Hz

The frame frequency of 80 Hz is factory calibrated with a tolerance of ± 3 Hz at 25 °C.

Table 24. Clock and frame frequency values

Duty cycle definition: % HIGH-level time : % LOW-level time.

FF[4:0]	Frame frequency (Hz)	Clock frequency (Hz)	Typical duty cycle (%)
00000	45	6472	29 : 71
00001	50	7200	20 : 80
00010	55	7945	12 : 88
00011	60	8662	4 : 96
00100	65	9366	48 : 52
00101	70	10105	44 : 56
00110	75	10766	41 : 59
00111	80	11520	36 : 64
01000	85	12255	32 : 68
01001	90	12944	29 : 71
01010	95	13714	24 : 76
01011	100	14400	20 : 80
01100	110	15781	13 : 87
01101	120	17194	5 : 95
01110	130	18581	49 : 51
01111	140	20211	44 : 56
10000	150	21736	40 : 60
10001	160	23040	36 : 64
10010	170	24511	32 : 68
10011	180	26182	28 : 72
10100	190	27429	24 : 76
10101	200	28800	20 : 80
10110	210	30316	16 : 84
10111	220	32000	12 : 88
11000	230	32914	9 : 91
11001	240	34909	4 : 96
11010	250	36000	50 : 50
11011	260	37161	49 : 51
11100	270	38400	47 : 53
11101	280	39724	45 : 55
11110	290	41143	43 : 57
11111	300	42667	41 : 59

8.7 Display RAM commands

8.7.1 Command: Write-display-data

The Write-display-data command writes data byte-wise to the RAM. After Power-On Reset (POR), the RAM content is random and should be brought to a defined status by clearing it (setting it logic 0).

Table 25. Write-display-data - write display data command bit description

For this command, the register selection bits have to be set $RS[1:0] = 01$.

Bit	Symbol	Value	Description
-	R/\overline{W}	0	fixed value
-	RS[1:0]	01	fixed value
7 to 0	DB[7:0]	00000000 to 11111111	writing data byte-wise to RAM

More information about the display RAM can be found in [Section 8.14 on page 51](#).

8.7.2 Bank select commands

For multiplex drive modes 1:2, and static drive mode, it is possible to write data to one area of the RAM while displaying from another. These areas are named as RAM banks. Input and output banks can be set independently from one another with the Input-bank-select and the Output-bank-select command. More information about RAM bank switching can be found in [Section 8.14.3 on page 53](#).

8.7.2.1 Command: Input-bank-select

Table 26. Input-bank-select - input bank select command bit description

This command is not applicable for multiplex drive mode 1:4.

Bit	Symbol	Value	Description	
-	R/\overline{W}	0	fixed value	
-	RS[1:0]	00	fixed value	
7 to 2	-	000010	fixed value	
1 to 0	IB[1:0]	selects RAM bank to write to		
		static drive mode		
		1:2 drive mode		
		00	bank 0: RAM-row 0	bank 0: RAM-rows 0 and 1
		01	bank 1: RAM-row 1	
		10	bank 2: RAM-row 2	bank 2: RAM-rows 2 and 3
		11	bank 3: RAM-row 3	

8.7.2.2 Command: Output-bank-select

Table 27. Output-bank-select - output bank select command bit description

This command is not applicable for multiplex drive mode 1:4.

Bit	Symbol	Value	Description	
-	$\overline{R/W}$	0	fixed value	
-	RS[1:0]	00	fixed value	
7 to 2	-	000100	fixed value	
1 to 0	OB[1:0]	selects RAM bank to read from to the LCD		
			static drive mode	1:2 drive mode
		00	bank 0: RAM-row 0	bank 0: RAM-rows 0 and 1
		01	bank 1: RAM-row 1	
		10	bank 2: RAM-row 2	bank 2: RAM-rows 2 and 3
		11	bank 3: RAM-row 3	

8.7.3 Command: Data-pointer

The Data-pointer command defines the display RAM address where the following display data are sent to. For setting the data pointer always the three commands Data-pointer-init, Data-pointer-MSB and Data-pointer-LSB have to be sent.

Table 28. Data-pointer - set data pointer command bit description

For further information about the RAM, see [Section 8.14 on page 51](#).

Bit	Symbol	Value	Description
Data-pointer-init			
-	$\overline{R/W}$	0	fixed value
-	RS[1:0]	00	fixed value
7 to 0	-	10100000	fixed value
Data-pointer-MSB: PX[6:4]			
-	$\overline{R/W}$	0	fixed value
-	RS[1:0]	00	fixed value
7 to 3	-	10000	fixed value
2 to 0	PX[6:4]	000 to 111	3-bit binary value
Data-pointer-LSB: PX[3:0]			
-	$\overline{R/W}$	0	fixed value
-	RS[1:0]	00	fixed value
7 to 4	-	1001	fixed value
3 to 0	PX[3:0]	0000 to 1111	4-bit binary value

8.8 Start-up and shut-down

8.8.1 Power-On

At power-on, the PCA8530 resets to the following starting conditions:

1. All backplane and segment outputs are set to V_{SS1} .
2. Input and output bank selectors are reset.
3. The interface is initialized.
4. The data pointer is cleared (set logic 0).
5. The internal oscillator is disabled.
6. Temperature measurement is disabled.
7. Temperature filter is disabled.
8. The internal V_{LCD} voltage generation is disabled. The charge pump is switched off.
9. The V_{LCD} temperature compensation is disabled.
10. The display is disabled.

8.8.2 Recommended start-up sequences

General remarks:

1. Do not transfer data for at least 1 ms after a power-on to allow the reset action to complete.
2. The first command sent to the device after the power-on event must be the Initialize command (see [Section 8.2.1.1 on page 10](#)).
3. After the initialization, the desired values have to be set by the commands listed in [Table 5 on page 8](#).
4. Before enabling the display, the RAM content should be brought to a defined status
 - by clearing it (setting it all logic 0) or
 - by writing meaningful content (for example, a graphic)otherwise unwanted display artifacts may appear on the display.

The following sequences describe how to proceed with the initialization of the chip in different application modes.

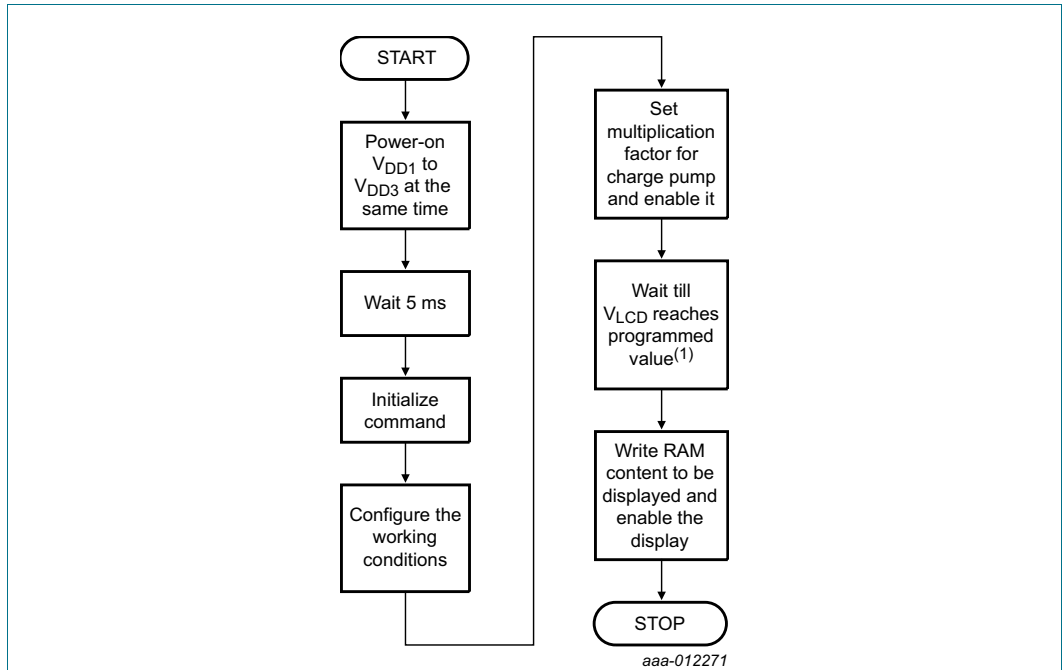

(1) This time depends on the external capacitor on the V_{LCD} pins. For a capacitor of 100 nF a delay of about 55 ms to 65 ms is expected.

Fig 3. Recommended start-up sequence when using the internal charge pump and the internal clock signal

When using the internal V_{LCD} generation, the display must not be enabled before the generation of V_{LCD} with the internal charge pump is completed. Otherwise unwanted display artifacts may appear on the display.

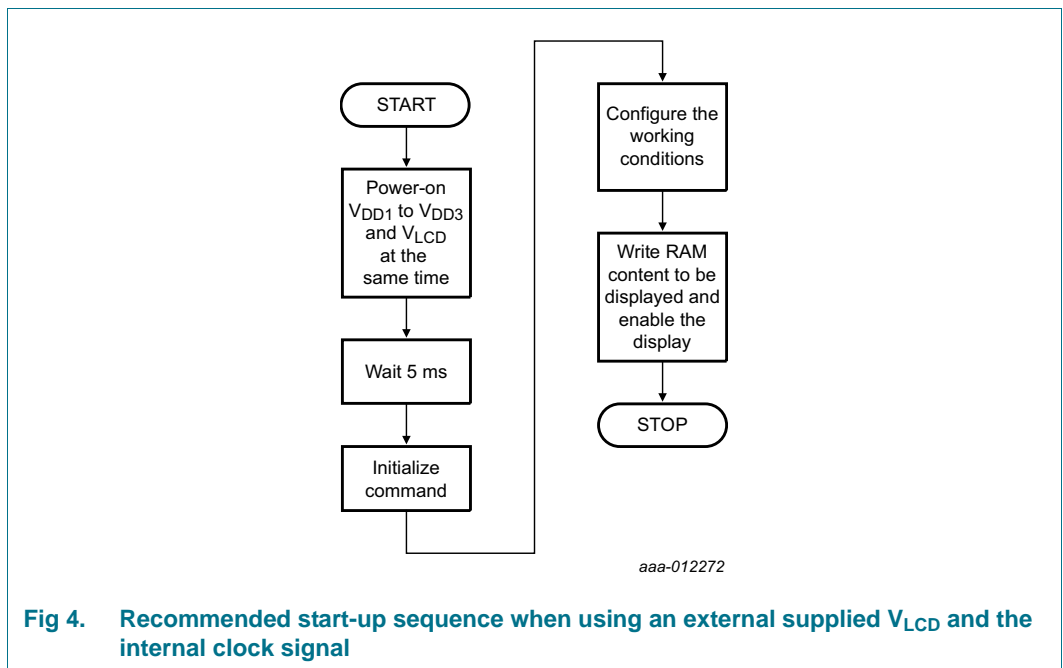
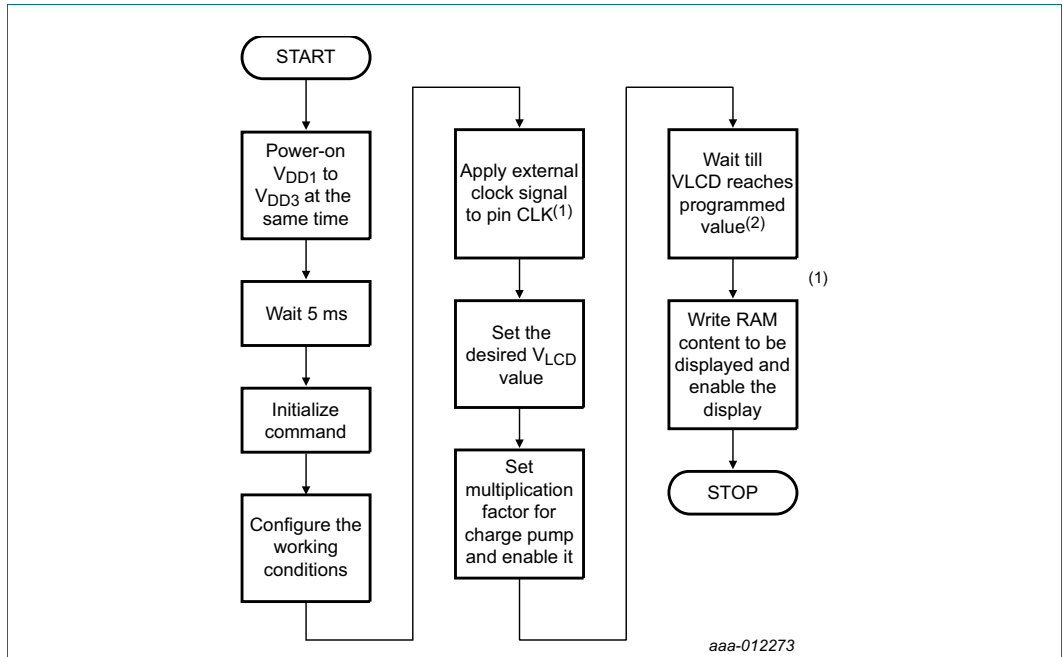

Fig 4. Recommended start-up sequence when using an external supplied V_{LCD} and the internal clock signal



- (1) Alternatively, the external clock signal can be applied after the generation of the V_{LCD} voltage.
- (2) This time depends on the external capacitor on the V_{LCD} pins. For a capacitor of 100 nF a delay of about 55 ms to 65 ms is expected.

Fig 5. Recommended start-up sequence when using the internal charge pump and an external clock signal

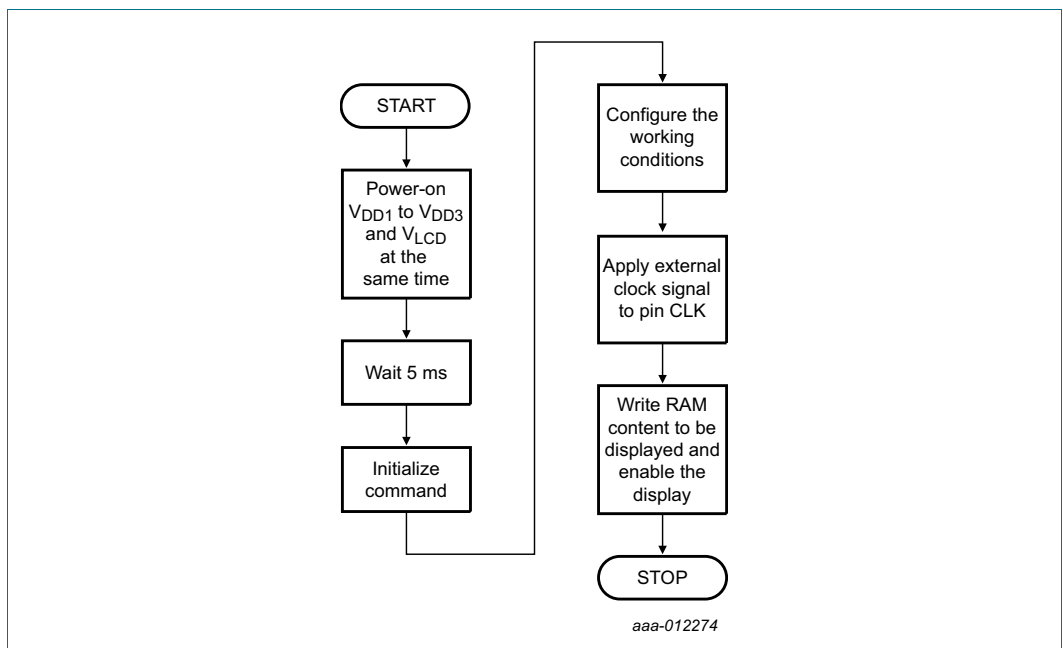

Fig 6. Recommended start-up sequence when using an external supplied V_{LCD} and an external clock signal

8.8.3 Recommended power-down sequences

General remarks:

1. It is necessary to run the power-down sequence before removing the supplies. Depending on the application, care must be taken that no other signals are present at the chip input or output pins when removing the supplies (refer to [Section 10 on page 63](#)). Otherwise this may cause unwanted display artifacts. Uncontrolled removal of supply voltages does not damage the PCA8530.
2. Static voltages across the liquid crystal display can build up when the external LCD supply voltage (V_{LCD}) is on while the IC supply voltage (V_{DD1} to V_{DD3}) is off, or the other way round. This may cause unwanted display artifacts. To avoid such artifacts, external V_{LCD} , V_{DD1} to V_{DD3} must be applied or removed together.
3. A clock signal must always be supplied to the device when the device is active. Removing the clock may freeze the LCD in a DC state, which is not suitable for the liquid crystal. It is recommended to disable the display first and to remove the clock signal afterwards.

With the following sequences, the PCA8530 can be set to a state of minimum power consumption, called power-down mode.

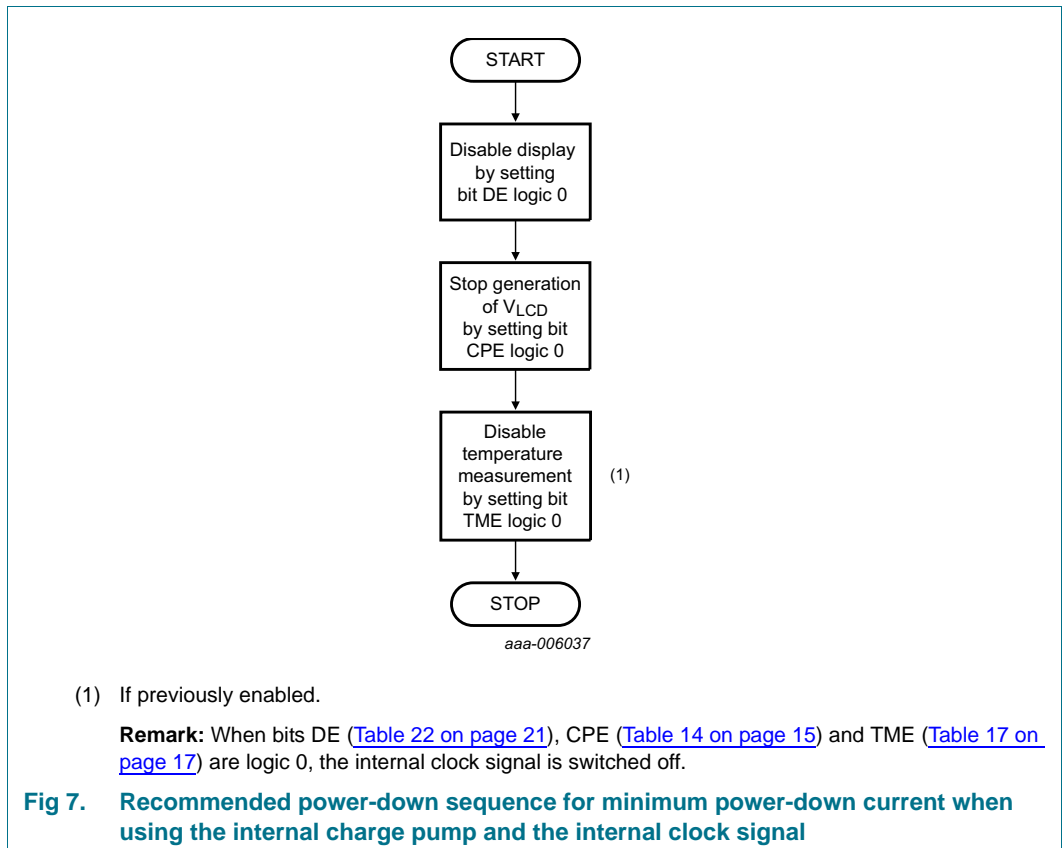

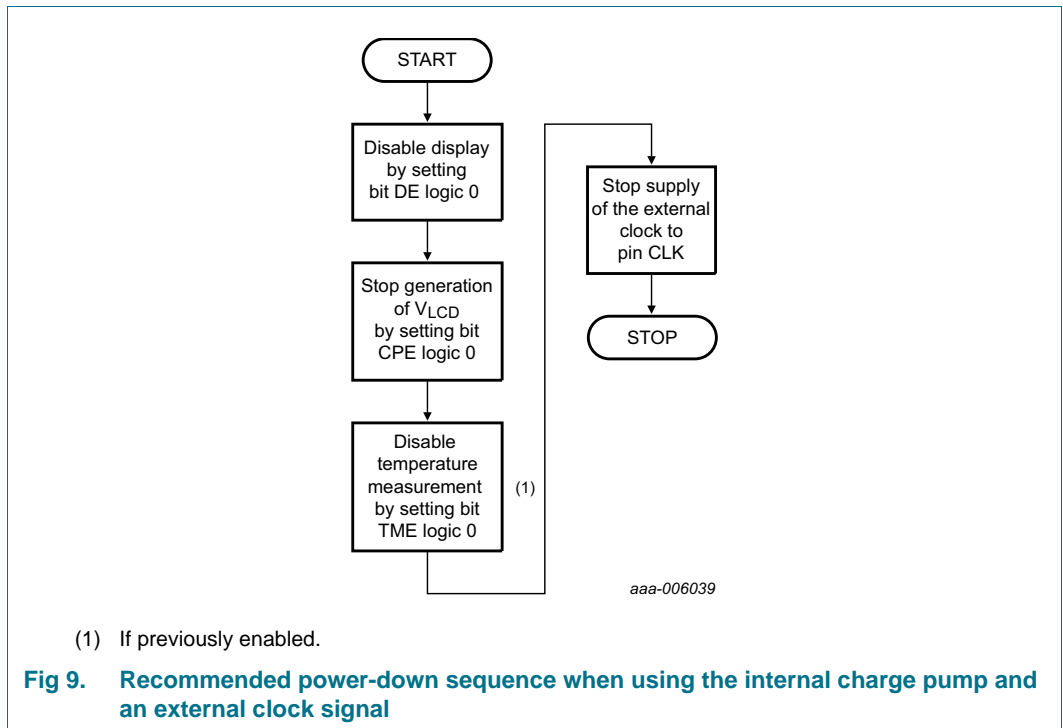
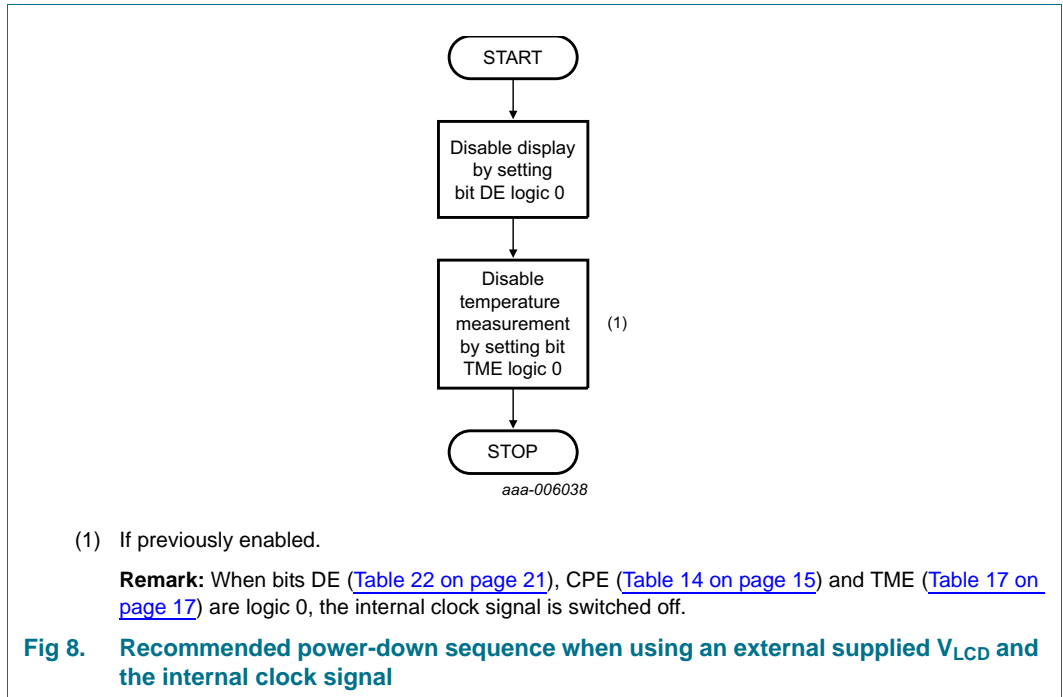

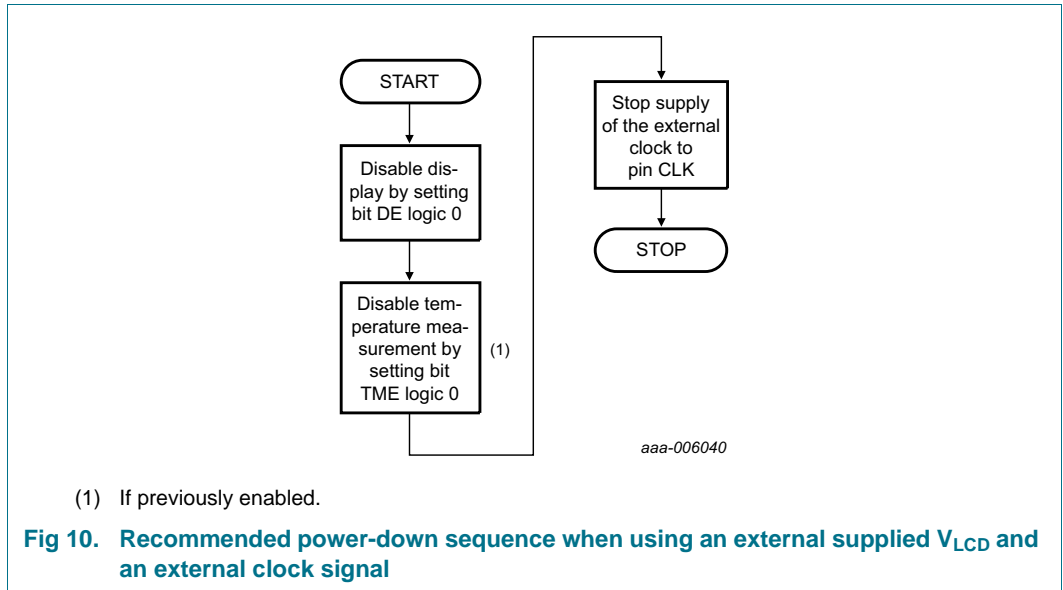

8.9 Possible display configurations

The display configurations possible with the PCA8530 depend on the number of active backplanes outputs required. A selection of possible display configurations is given in [Table 29](#).

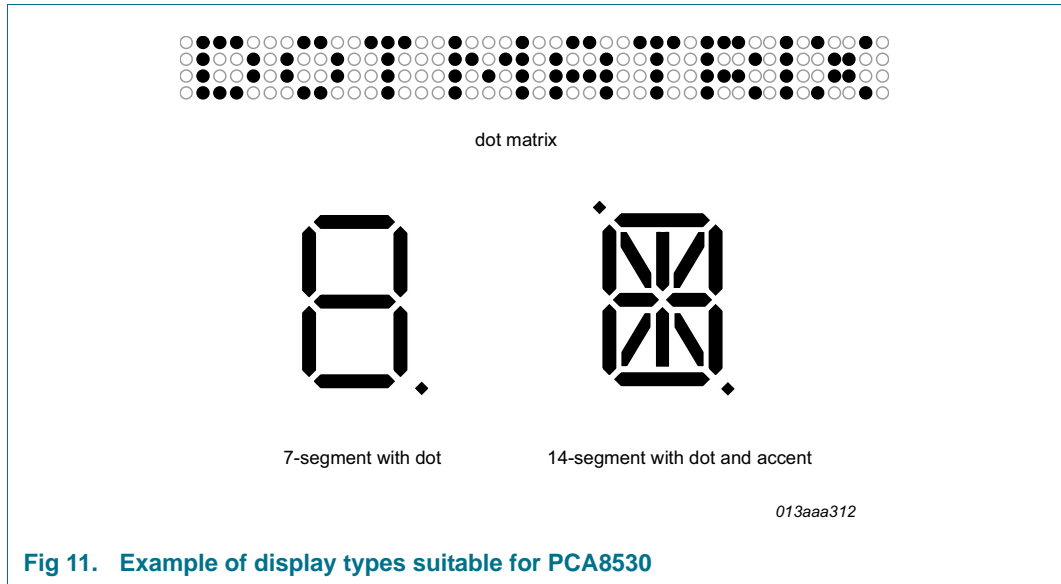

Fig 11. Example of display types suitable for PCA8530

Table 29. Selection of possible display configurations

Number of				
Backplanes	Icons	Digits/Characters		Dot matrix: Segments/ Elements
		7-segment ^[1]	14-segment ^[2]	
4	408	51	25	408 dots (4 × 102)
2	204	25	12	204 dots (2 × 102)
1	102	12	6	102 dots (1 × 102)

[1] 7 segment display has 8 segments/elements including the decimal point.

[2] 14 segment display has 16 segments/elements including decimal point and accent dot.

All the display configurations in [Table 29](#) can be implemented in the typical systems shown in [Figure 12](#) and [Figure 13](#).

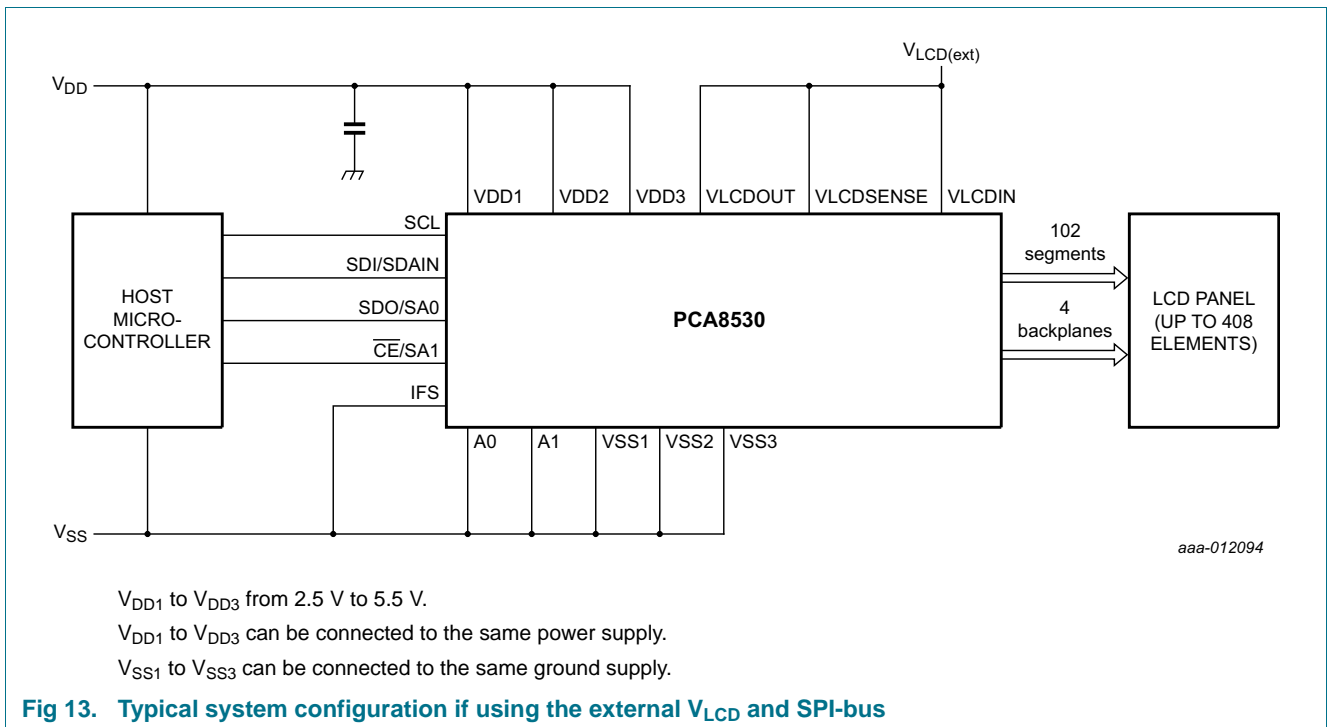
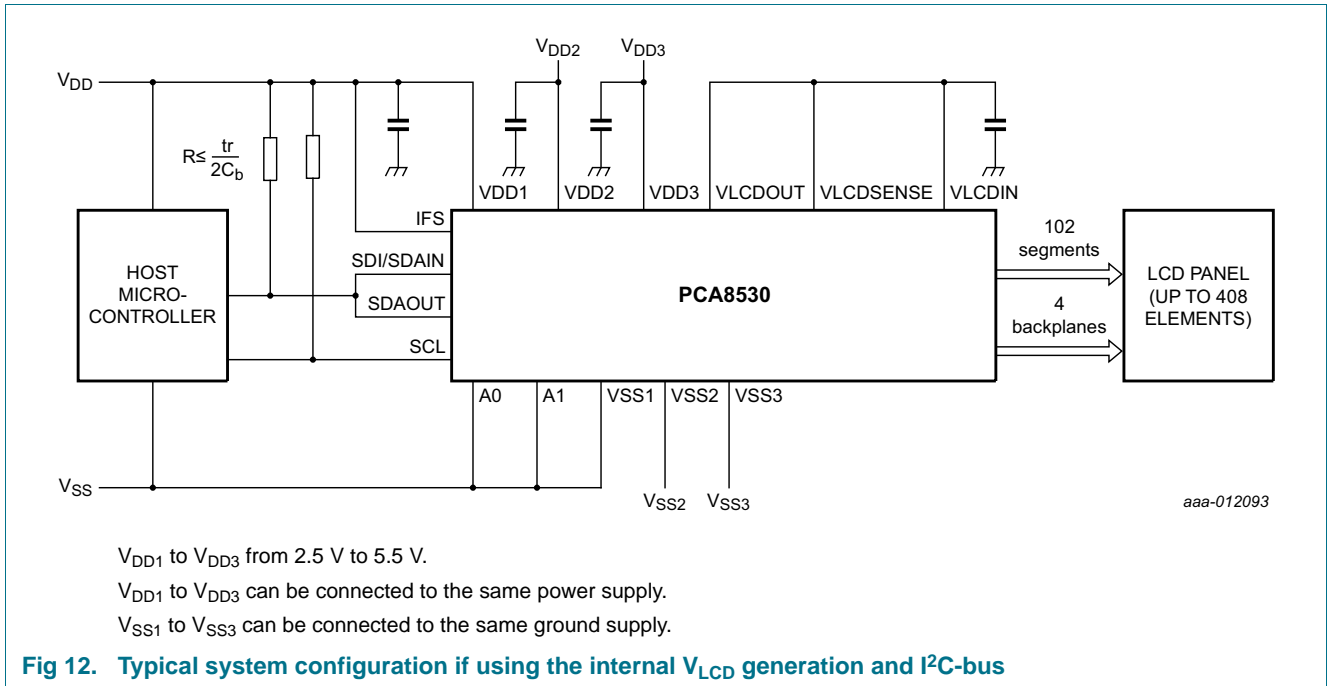

The host microcontroller maintains the communication channel with the PCA8530. The only other connections required to complete the system are the power supplies, the V_{LCD} pins, the external capacitors, and the LCD panel selected for the application. The appropriate biasing voltages for the multiplexed LCD waveforms are generated internally.

External capacitors of 100 nF minimum are required on each of the pins VDD1 to VDD3. VDD1 to VDD3 can be connected to the same power supply. In this case, a capacitor of 300 nF minimum is required.

VSS1 to VSS3 can be connected to the same ground supply.

The VLCD pins (VLCDOUT, VLCDSENSE, VLCDIN) can be connected, whether V_{LCD} is generated internally or supplied from external. An external capacitor of 300 nF minimum is recommended for VLCD. For high display loads, 1 μ F is suggested.

8.10 LCD voltage

8.10.1 V_{LCD} pins

The PCA8530 has 3 V_{LCD} pins:

VLCDIN — V_{LCD} supply input

VLCDOUT — V_{LCD} voltage output

VLCDSENSE — V_{LCD} regulation circuitry input

The V_{LCD} voltage can be generated on-chip or externally supplied.

8.10.2 External V_{LCD} supply

When the external V_{LCD} supply is selected (CPE = 0), the V_{LCD} voltage must be supplied to the pin VLCDIN. The pins VLCDOUT and VLCDSENSE can be left unconnected or alternatively connected to VLCDIN.

The internal charge pump must not be enabled, otherwise an extra current may occur on pin VDD2 and pin VLCD. When V_{LCD} is supplied externally, no internal temperature compensation occurs on this voltage even if bit TCE is set logic 1 (see [Section 8.10.4](#)). The V_{LCD} voltage which is supplied externally will be available at the segments and backplanes of the device through the chosen bias system. Also programming the V[8:0] bit field has no effect on the externally supplied V_{LCD} .

8.10.3 Internal V_{LCD} generation

When the internal V_{LCD} generation is selected (CPE = 1), the V_{LCD} voltage is available on pin VLCDOUT. The pins VLCDIN and VLCDSENSE must be connected to the pin VLCDOUT.

V_{LCD} can be generated by an on-chip charge pump and controlled by command ([Table 15 on page 15](#)). The V_{LCD} voltage is available on pin VLCDOUT.

The charge pump is controlled by the Charge-pump-ctrl command (see [Table 14 on page 15](#)). It can be enabled with the CPE bit. The multiplier setting can be configured with the CPC[2:0] bits. The charge pump can generate a V_{LCD} up to $5 \times V_{DD2}$.

8.10.3.1 V_{LCD} programming

V_{LCD} can be programmed by using the V[8:0] (see [Table 15 on page 15](#)).

The final value of V_{LCD} is a combination of the programmed V[8:0] value and the output of the temperature compensation block, VT[8:0] (see [Equation 2](#)). The system is exemplified in [Figure 14](#).

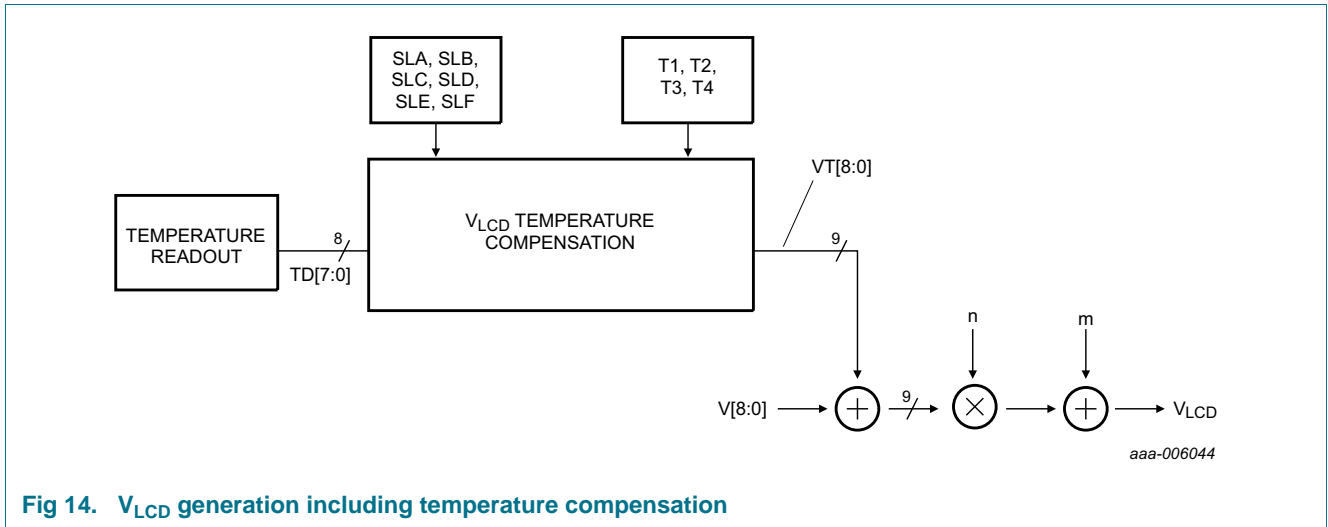

Fig 14. V_{LCD} generation including temperature compensation

In [Equation 2](#) the main parameters are the programmed digital value term and the compensated temperature term.

$$V_{LCD} = [V[8:0] + VT[8:0]] \times n + m \tag{2}$$

1. V[8:0] is the binary value of the programmed voltage.
2. VT[8:0] is the binary value of the temperature compensated voltage. Its value comes from the temperature compensation block and is a two's complement which has the value 0h at 20 °C.
3. m and n are fixed values (see [Table 30](#) and [Figure 15](#)).

Table 30. Parameters of V_{LCD} generation

Symbol	Value	Unit
m	3.99	V
n	0.03	V

[Figure 15](#) shows how V_{LCD} changes with the programmed value of V[8:0].

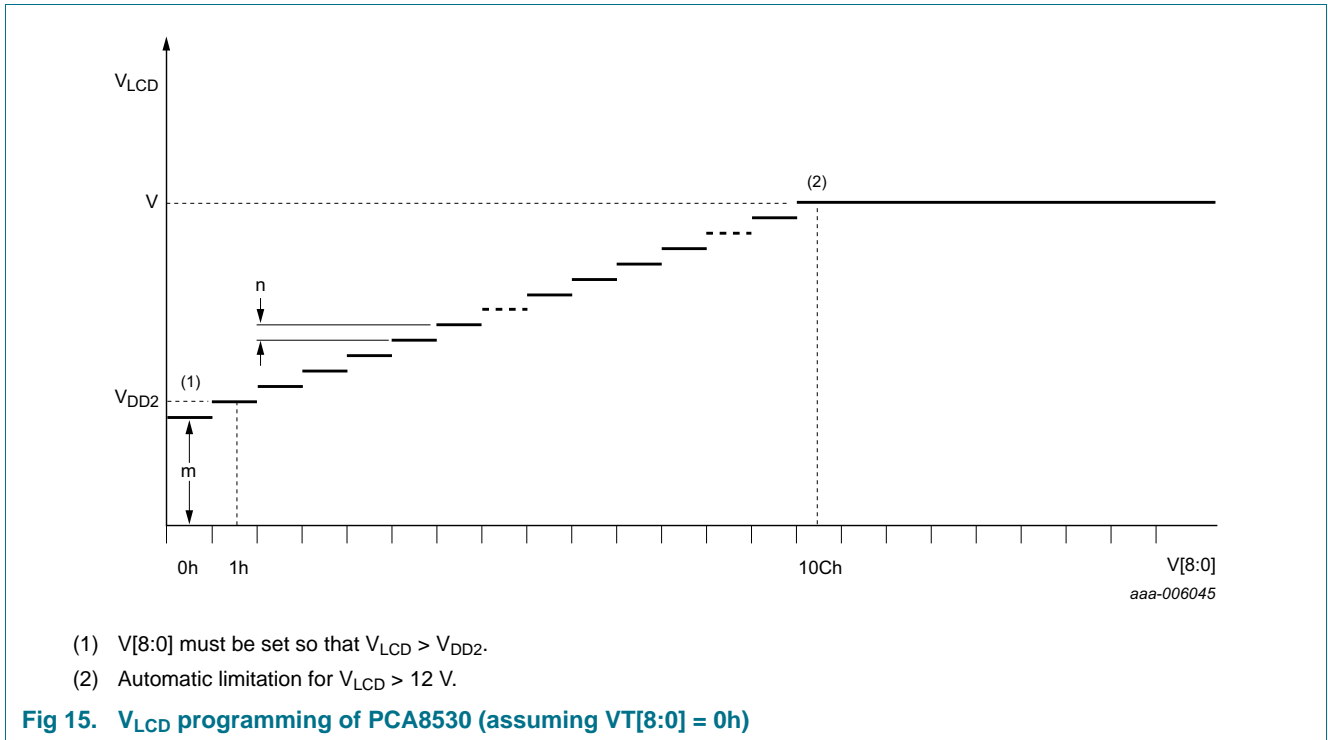

Remarks:

1. It is important that $V[8:0]$ is set to such a value that the resultant V_{LCD} , including the temperature compensation $V_T[8:0]$, is higher than V_{DD2} .
2. Programmable range of $V[8:0]$ is from $0h$ to $1FFh$. This would allow achieving a V_{LCD} above 12 V but 12 V is the built-in automatic limit.

8.10.3.2 V_{LCD} driving capability

Figure 16 illustrates the main factor determining how much current the charge pump can deliver.

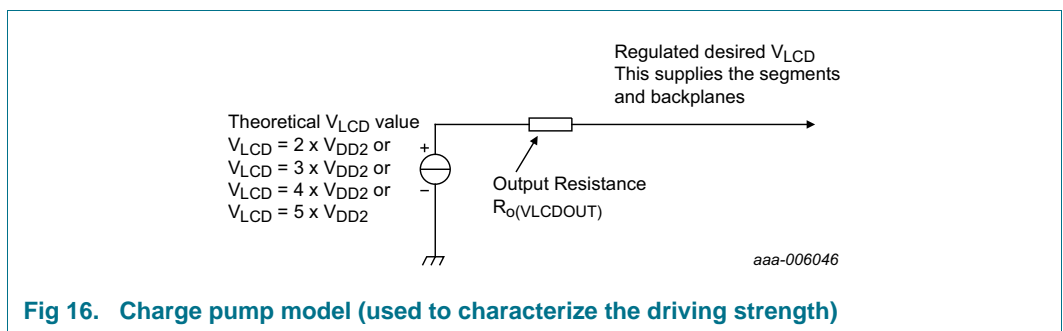

The output resistance of the charge pump is specified in Table 31.

Table 31. Output resistance of the charge pump

$R_{ITO(VSS2)}, R_{ITO(VDD2)}, R_{ITO(VLCDOUT)} = 50 \Omega$.

Charge pump configuration	$R_{o(VLCDOUT)}$ (typical)	Unit
$V_{LCD} = 2 \times V_{DD2}$	2.5	k Ω
$V_{LCD} = 3 \times V_{DD2}$	6	k Ω
$V_{LCD} = 4 \times V_{DD2}$	10.5	k Ω
$V_{LCD} = 5 \times V_{DD2}$	18	k Ω

Remark: The PCA8530 has a built-in automatic limitation of V_{LCD} , set to 12 V. The maximum V_{LCD} that can be programmed is expressed by the following equation:

$V_{LCD(max)} = \min(12 \text{ V}, n \times V_{DD2} - R_{o(VLCDOUT)} \times I_{load})$, where n is the multiplication factor of the charge pump. I_{load} is the overall current sink by the segments and backplanes outputs depending on the display, plus the on-chip V_{LCD} current consumption.

With these values, it can be calculated how much current the charge pump can drive under certain conditions, as shown in [Figure 17](#) and [Figure 18](#).

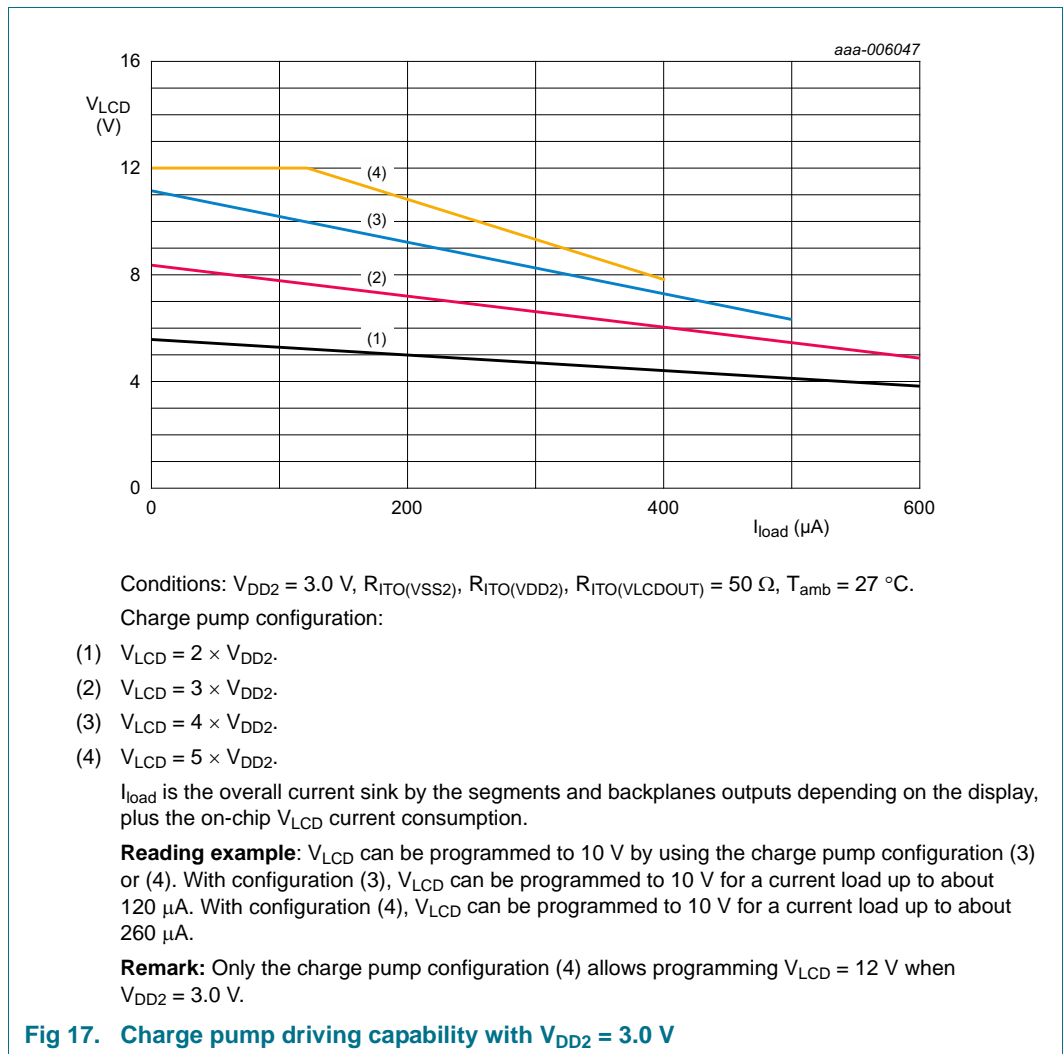

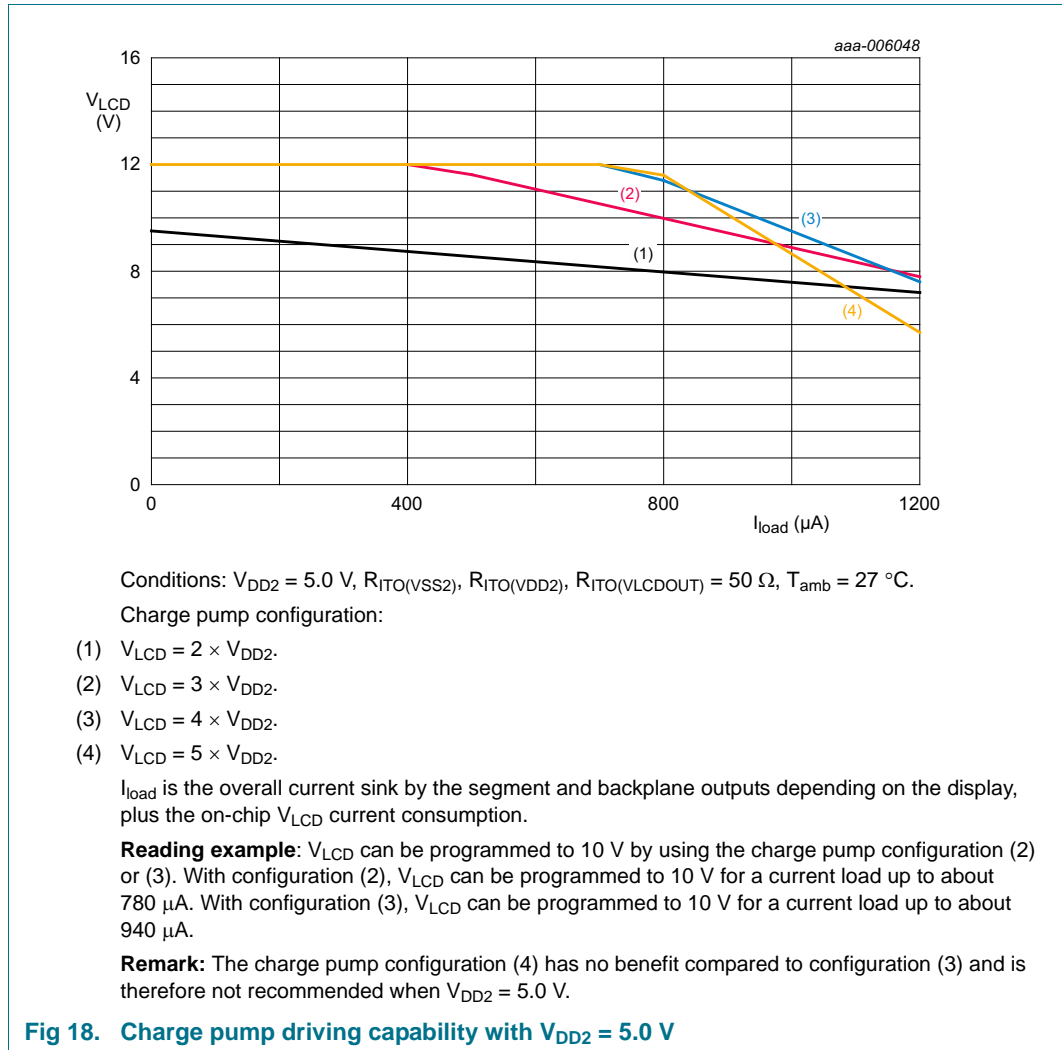

It has to be considered that the driving capability of the charge pump is depending on the resistance of the Indium Tin Oxide (ITO) tracks, see [Figure 20](#) and [Figure 19](#).

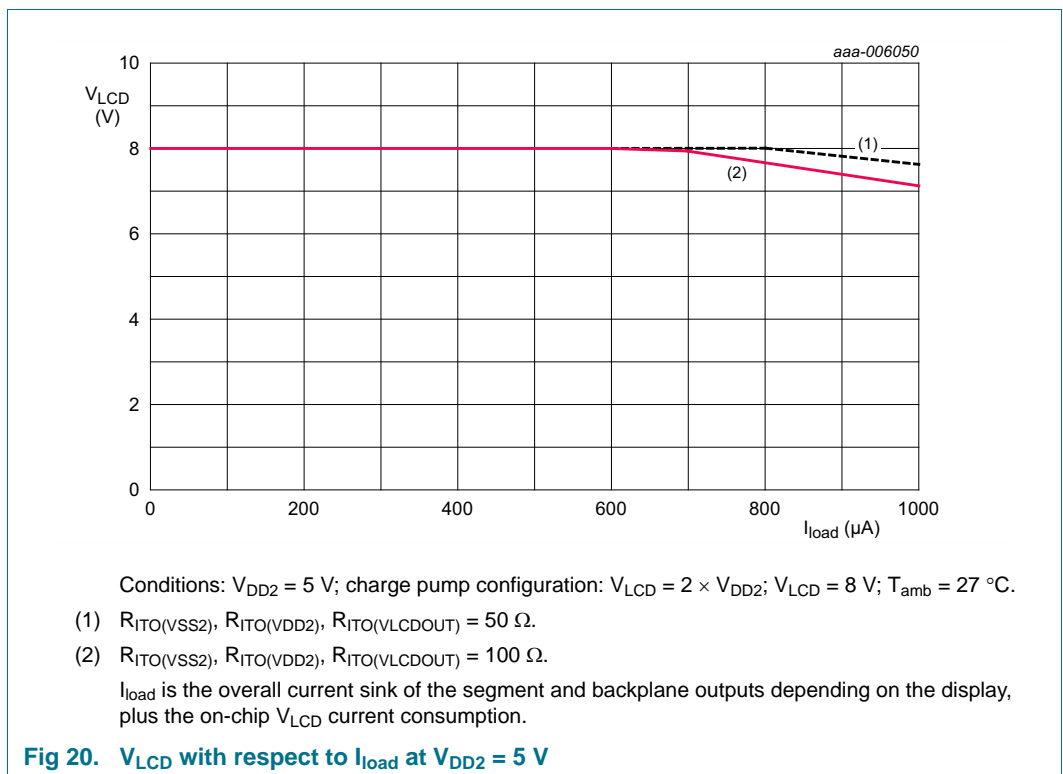
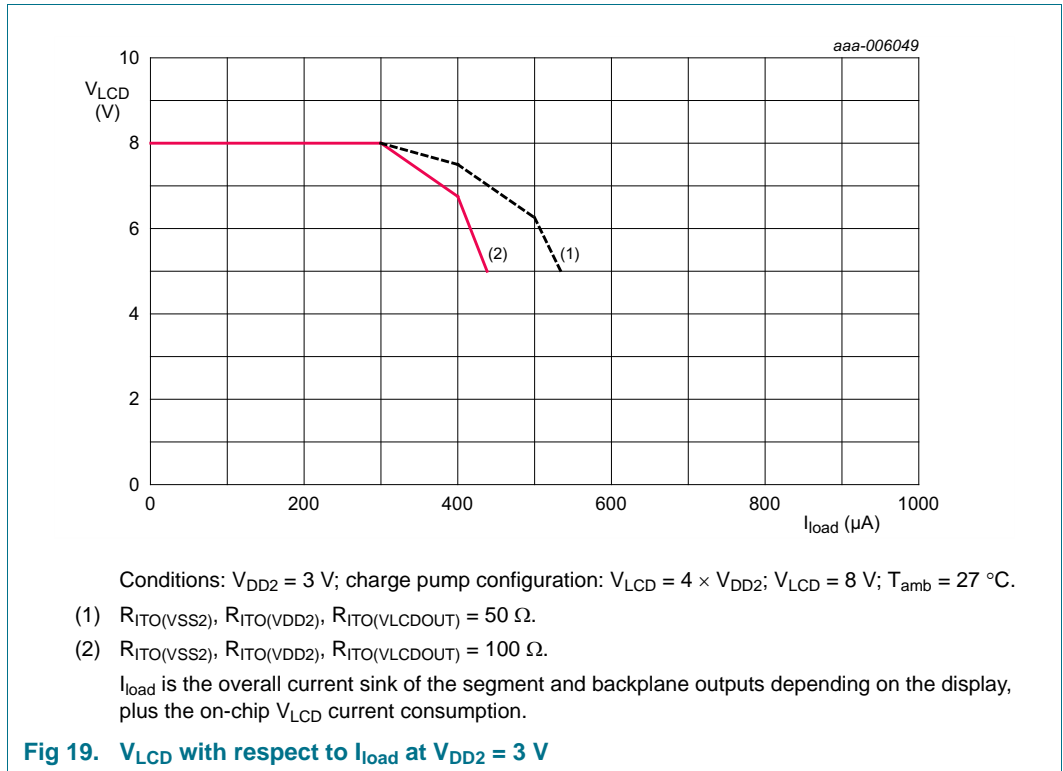

8.10.4 Temperature measurement and temperature compensation of V_{LCD}

8.10.4.1 Temperature readout

The PCA8530 has a built-in temperature sensor which provides an 8-bit digital value (TD[7:0]) of the ambient temperature. This value can be read by command (see [Section 8.2.6 on page 12](#) and [Section 8.2.7 on page 13](#)). The actual temperature is determined from TD[7:0] using [Equation 3](#).

$$T(^{\circ}C) = 0.6275 \times TD[7:0] - 40 \tag{3}$$

TD[7:0] = FFh means that no temperature readout is available or was performed. The measurement needs about 8 ms to complete. It is repeated periodically every second as long as bit TME is set logic 1 (see [Table 17 on page 17](#)).

Due to the nature of a temperature sensor, oscillations may occur. To avoid this, a filter has been implemented in PCA8530. A control bit, TMF, is implemented to enable or disable the digital temperature filter (see [Table 17 on page 17](#)). The system is exemplified in [Figure 21](#).

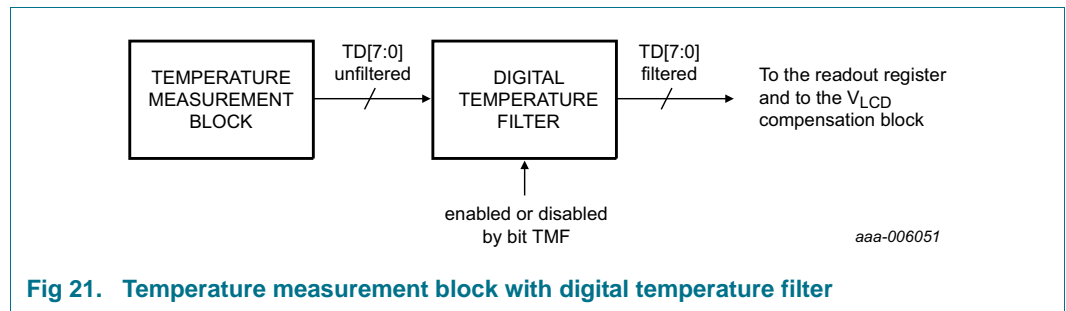
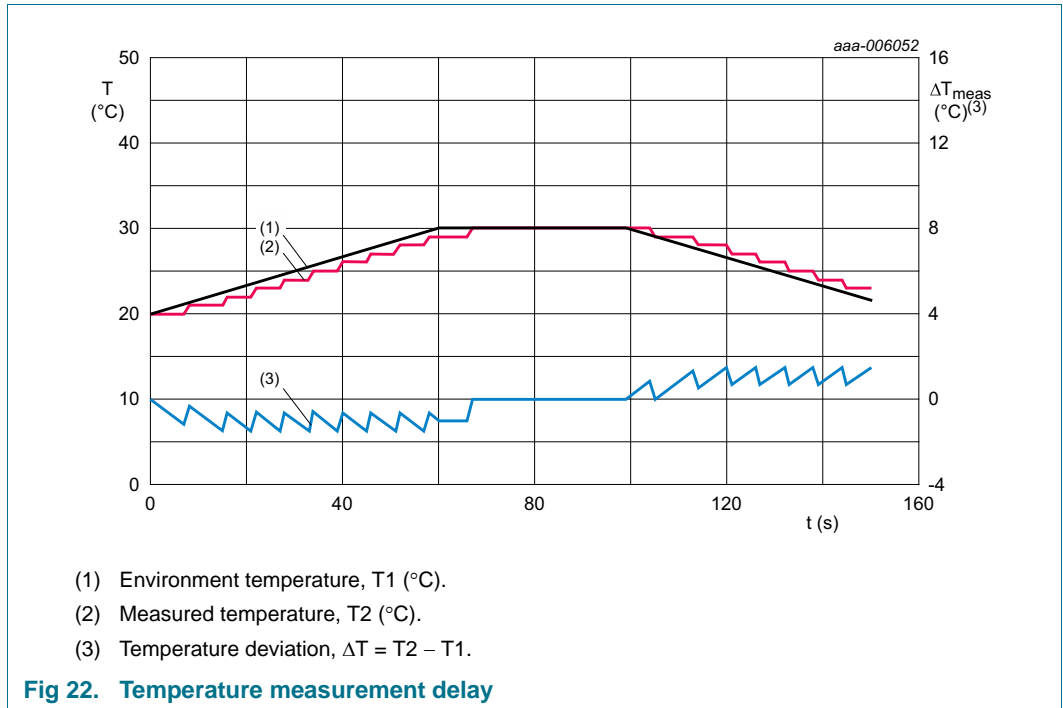

Fig 21. Temperature measurement block with digital temperature filter

The digital temperature filter introduces a certain delay in the measurement of the temperature. This behavior is illustrated in [Figure 22](#).



8.10.4.2 Temperature adjustment of the V_{LCD}

Due to the temperature dependency of the liquid crystal viscosity, the LCD supply voltage may have to be adjusted at different temperatures to maintain optimal contrast. The temperature characteristics of the liquid is provided by the LCD manufacturer. The slope has to be set to compensate for the liquid behavior. Internal temperature compensation can be enabled via bit TCE (see [Table 17 on page 17](#)).

The ambient temperature range is split up to six programmable regions and to each a different temperature coefficient can be applied (see [Figure 23](#)).

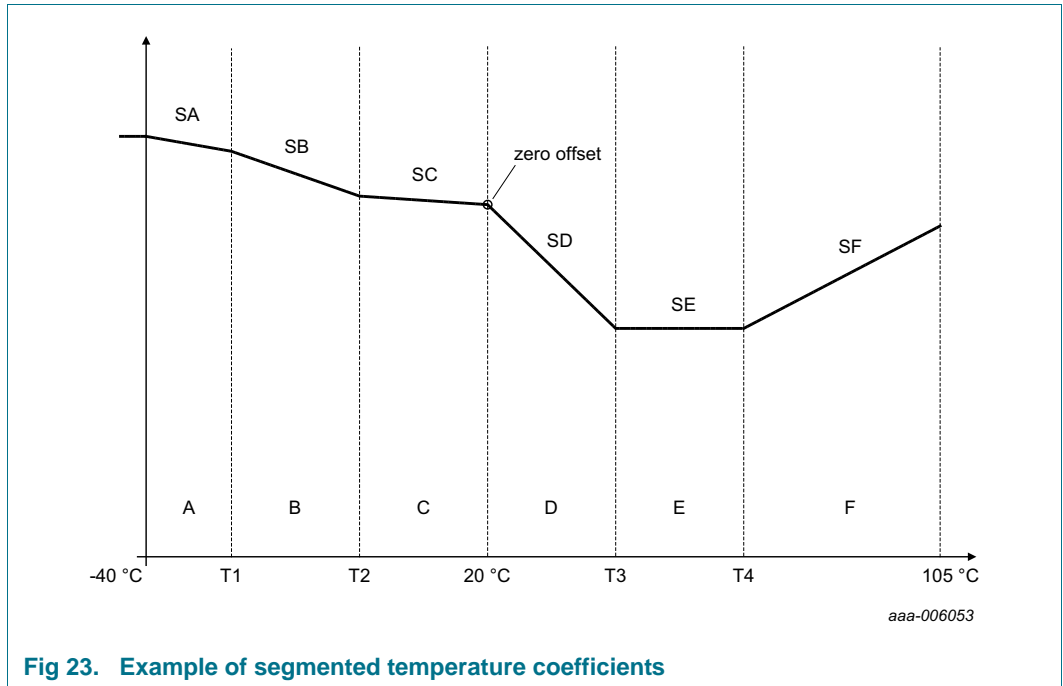

Fig 23. Example of segmented temperature coefficients

The temperature regions are determined by programming the temperature limits T1 to T4 via the TC-set-1 to TC-set-4 commands (see [Section 8.4.2 on page 18](#)). The temperature coefficients can be selected from a choice of eight different slopes. Each one of these coefficients is independently selected via the TC-slope command (see [Section 8.4.3 on page 19](#)).

Table 32. Temperature regions

T1T[2:0] to T4T[2:0]	Temperature region 1 and 2		Temperature region 3 and 4	
	T1, T2 (°C)	Corresponding TD value ^[1]	T3, T4 (°C)	Corresponding TD value ^[1]
000	-34	10	+29	110
001	-27	20	+38	124
010	-21	30	+47	138
011	-15	40	+55	152
100	-9	50	+64	166
101	-2	60	+73	180
110	+4	70	+82	194
111	+10	80	+91	208

[1] The relation between the actual temperature and TD[7:0] is derived from [Equation 3 on page 40](#).

Remark: The programming has to be made such that T1 < T2 and T3 < T4 otherwise the V_{LCD} temperature compensation will not be executed.

Table 33. Temperature coefficients

TSA[2:0] to TSF[2:0] value	Slope factor (mV/°C)	Temperature coefficients SA to SF ^[1]
000	0	0.000
001	-6	-0.125
010	-12	-0.250
011	-24	-0.500
100	-60	-1.250
101	+6	+0.125
110	+12	+0.250
111	+24	+0.500

[1] The relationship between the temperature coefficients SA to SF and the slope factor is derived from the following equation: $S_n = \frac{0.6275(°C)}{LSB\ of\ V[8:0](mV)} \times slope\ factor\ (mV/°C)$, where $LSB\ of\ V[8:0] \cong 30\ mV$.

The binary value of the temperature compensated voltage VT[8:0] is calculated according to [Table 34](#).

Table 34. Calculation of the temperature compensated value VT

Temperature (°C)	Digital temperature: TD[7:0]	Binary value of the temperature compensated voltage: VT[8:0]
$T \leq -40\ °C$	$TD[7:0] = 0$	$-(96 - T2) \times SC - (T2 - T1) \times SB - T1 \times SA$
$-40\ °C < T \leq T1$	$0 < TD[7:0] \leq T1$	$-(96 - T2) \times SC - (T2 - T1) \times SB - (T1 - TD[7:0]) \times SA$
$T1 < T \leq T2$	$T1 < TD[7:0] \leq T2$	$-(96 - T2) \times SC - (T2 - TD[7:0]) \times SB$
$T2 < T \leq 20\ °C$	$T2 < TD[7:0] \leq 96$	$-(96 - TD[7:0]) \times SC$
$20\ °C < T \leq T3$	$96 < TD[7:0] \leq T3$	$(TD[7:0] - 96) \times SD$
$T3 < T \leq T4$	$T3 < TD[7:0] \leq T4$	$(T3 - 96) \times SD + (TD[7:0] - T3) \times SE$
$T4 < T \leq 105\ °C$	$T4 < TD[7:0] \leq 231$	$(T3 - 96) \times SD + (T4 - T3) \times SE + (TD[7:0] - T4) \times SF$

8.10.5 LCD voltage selector

The LCD voltage selector co-ordinates the multiplexing of the LCD in accordance with the selected LCD drive configuration. The operation of the voltage selector is controlled by the Set-bias-mode command (see [Table 16 on page 16](#)) and the Set-MUX-mode command (see [Table 20 on page 20](#)).

Table 35. LCD drive modes: summary of characteristics

LCD drive mode	Number of:		LCD bias configuration	$\frac{V_{off(RMS)}}{V_{LCD}}$	$\frac{V_{on(RMS)}}{V_{LCD}}$	$D = \frac{V_{on(RMS)}}{V_{off(RMS)}} [1]$	$V_{LCD} [2]$
	Backplanes	Levels					
static	1	2	static	0	1	∞	$V_{on(RMS)}$
1:2 multiplex	2	3	$\frac{1}{2}$	0.354	0.791	2.236	$2.828 \times V_{off(RMS)}$
1:2 multiplex	2	4	$\frac{1}{3}$	0.333	0.745	2.236	$3.0 \times V_{off(RMS)}$
1:4 multiplex ^[3]	4	3	$\frac{1}{2}$	0.433	0.661	1.527	$2.309 \times V_{off(RMS)}$
1:4 multiplex	4	4	$\frac{1}{3}$	0.333	0.577	1.732	$3.0 \times V_{off(RMS)}$

[1] Determined from [Equation 6](#).

[2] Determined from [Equation 5](#).

[3] In this example, the discrimination factor and hence the contrast ratio is smaller. The advantage of this LCD drive mode is a power saving from a reduction of V_{LCD} .

Intermediate LCD biasing voltages are obtained from an internal voltage divider. The biasing configurations that apply to the preferred modes of operation, together with the biasing characteristics as functions of V_{LCD} and the resulting discrimination ratios (D), are given in [Table 35](#). Discrimination is a term which is defined as the ratio of the on and off RMS voltage across a segment. It can be thought of as a measurement of contrast.

A practical value for V_{LCD} is determined by equating $V_{off(RMS)}$ with a defined LCD threshold voltage ($V_{th(off)}$), typically when the LCD exhibits approximately 10 % contrast. In the static drive mode, a suitable choice is $V_{LCD} > 3V_{th(off)}$.

Bias is calculated by $\frac{1}{1+a}$, where the values for a are

a = 1 for $\frac{1}{2}$ bias

a = 2 for $\frac{1}{3}$ bias

The RMS on-state voltage ($V_{on(RMS)}$) for the LCD is calculated with [Equation 4](#):

$$V_{on(RMS)} = V_{LCD} \sqrt{\frac{a^2 + 2a + n}{n \times (1 + a)^2}} \tag{4}$$

where V_{LCD} is the resultant voltage at the LCD segment and where the values for n are

n = 1 for static mode

n = 2 for 1:2 multiplex

n = 4 for 1:4 multiplex

The RMS off-state voltage ($V_{off(RMS)}$) for the LCD is calculated with [Equation 5](#):

$$V_{off(RMS)} = V_{LCD} \sqrt{\frac{a^2 - 2a + n}{n \times (1 + a)^2}} \tag{5}$$

Discrimination is the ratio of $V_{on(RMS)}$ to $V_{off(RMS)}$ and is determined from [Equation 6](#):

$$D = \frac{V_{on(RMS)}}{V_{off(RMS)}} = \sqrt{\frac{a^2 + 2a + n}{a^2 - 2a + n}} \tag{6}$$

V_{LCD} is sometimes referred as the LCD operating voltage.

8.10.5.1 Electro-optical performance

Suitable values for $V_{on(RMS)}$ and $V_{off(RMS)}$ are dependent on the LCD liquid used. The RMS voltage, at which a pixel is switched on or off, determine the transmissibility of the pixel.

For any given liquid, there are two threshold values defined. One point is at 10 % relative transmission (at $V_{th(off)}$) and the other at 90 % relative transmission (at $V_{th(on)}$), see [Figure 24](#).

For a good contrast performance, the following rules should be followed:

$$V_{on(RMS)} \geq V_{th(on)} \tag{7}$$

$$V_{off(RMS)} \leq V_{th(off)} \tag{8}$$

$V_{on(RMS)}$ and $V_{off(RMS)}$ are properties of the display driver and are affected by the selection of a , n (see [Equation 4](#) to [Equation 6](#)) and the V_{LCD} voltage.

$V_{th(off)}$ and $V_{th(on)}$ are properties of the LCD liquid and can be provided by the module manufacturer. $V_{th(off)}$ is sometimes named V_{th} . $V_{th(on)}$ is sometimes named saturation voltage V_{sat} .

It is important to match the module properties to those of the driver in order to achieve optimum performance.

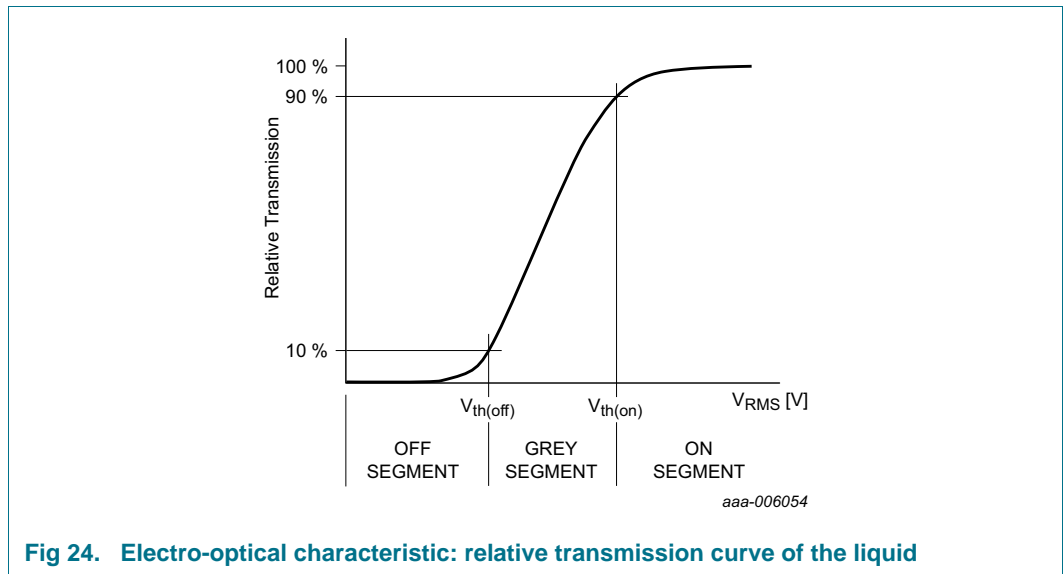
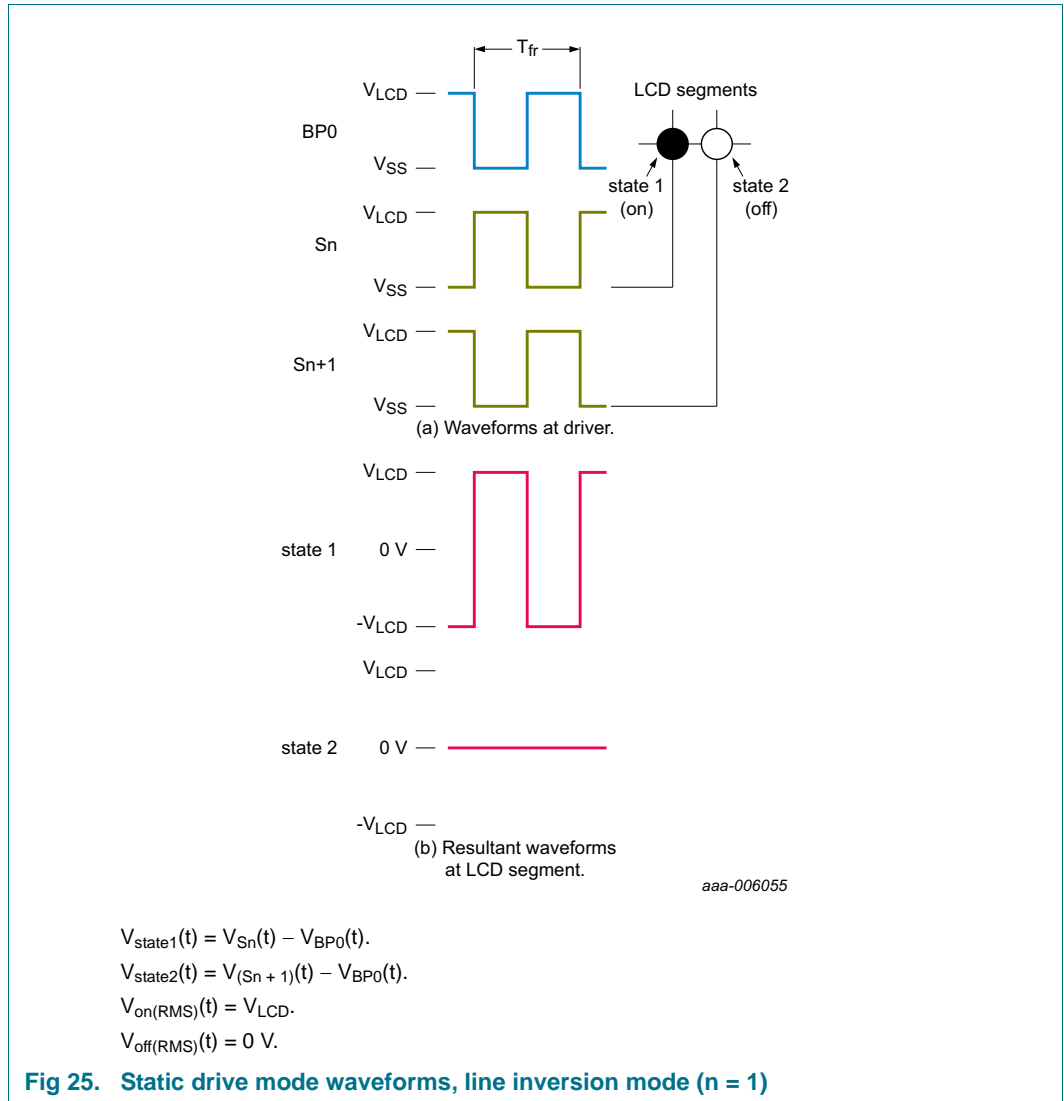

Fig 24. Electro-optical characteristic: relative transmission curve of the liquid

8.10.6 LCD drive mode waveforms

8.10.6.1 Static drive mode

The static LCD drive mode is used when a single backplane is provided in the LCD.



8.10.6.2 1:2 Multiplex drive mode

When two backplanes are provided in the LCD, the 1:2 multiplex mode applies. The PCA8530 allows the use of 1/2 bias or 1/3 bias in this mode as shown in Figure 26 and Figure 27.

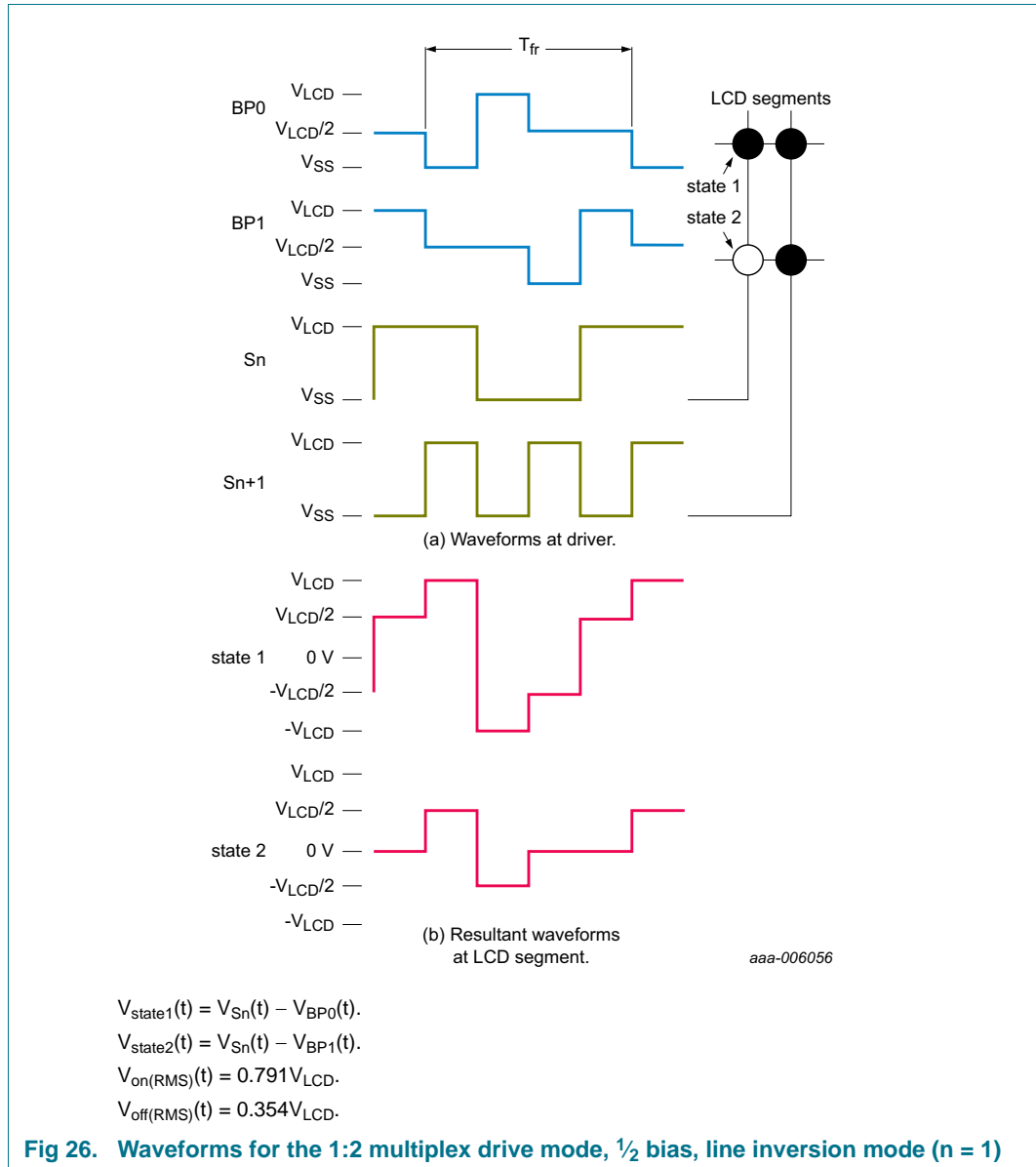
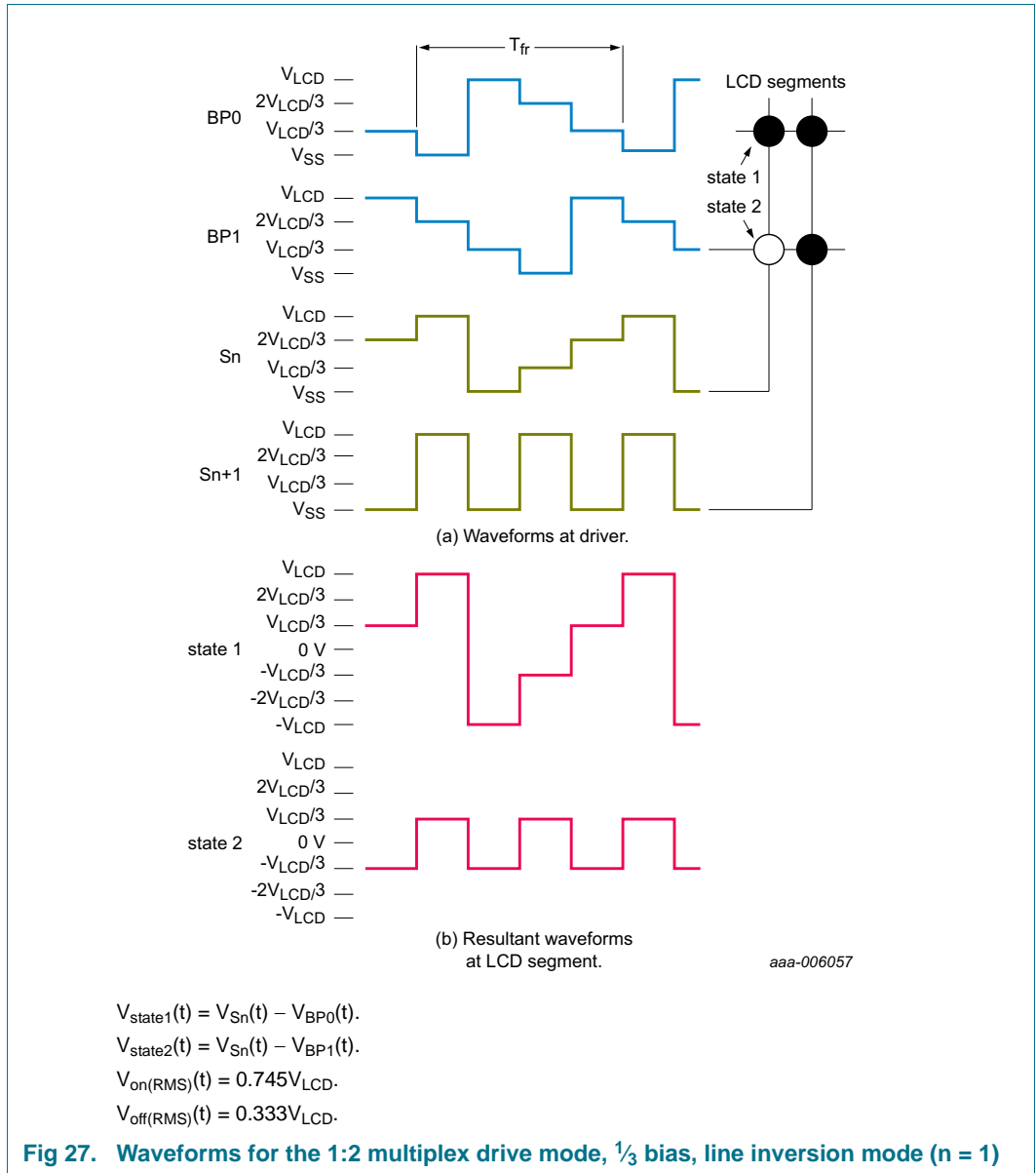
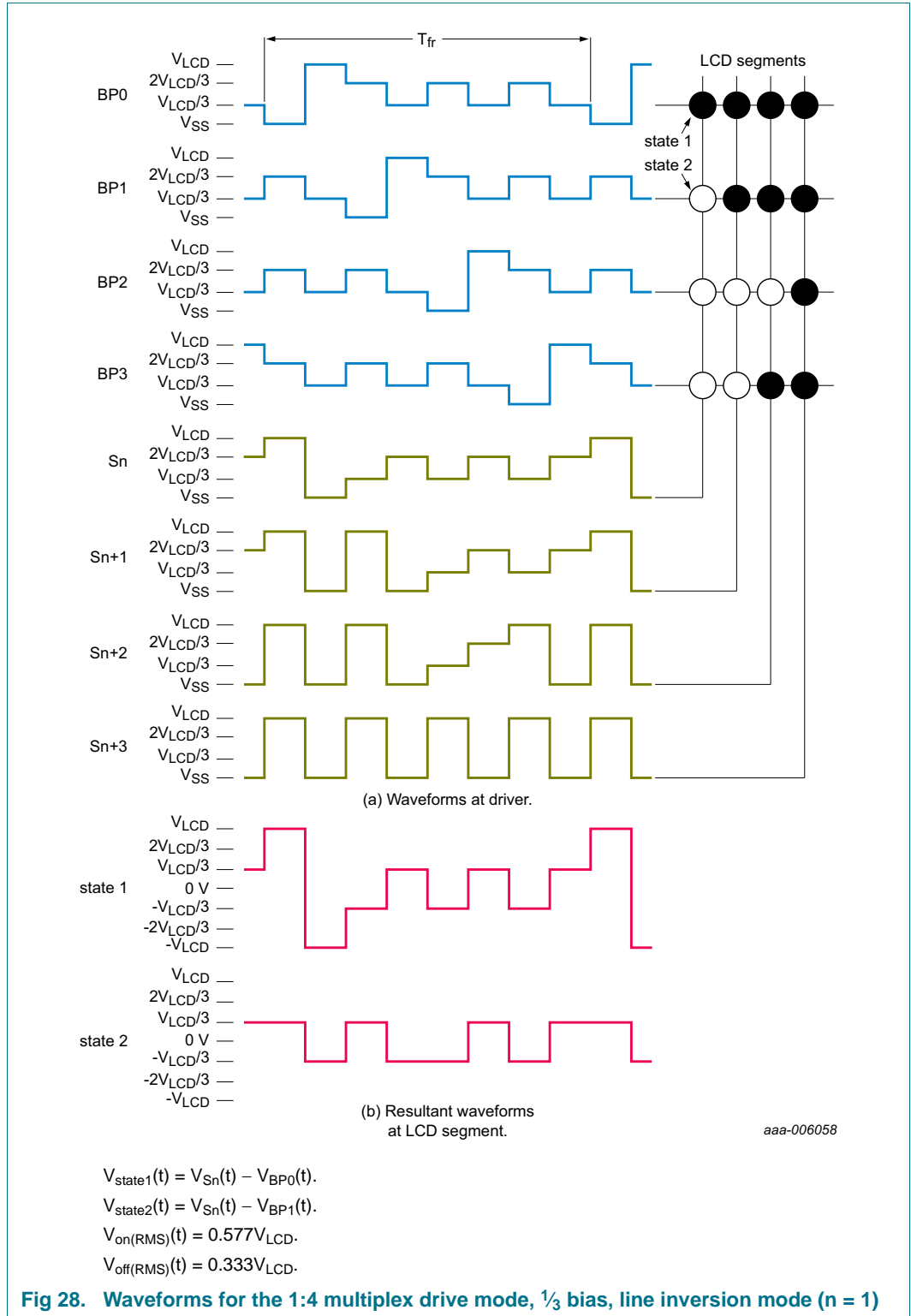

Fig 26. Waveforms for the 1:2 multiplex drive mode, 1/2 bias, line inversion mode (n = 1)



8.10.6.3 1:4 Multiplex drive mode

When four backplanes are provided in the LCD, the 1:4 multiplex drive mode applies, as shown in Figure 28.



8.11 Backplane outputs

The LCD drive section includes 4 backplane outputs: COM0 to COM3. The backplanes are double implemented to offer a higher flexibility for the glass layout.

The backplane output signals are generated based on the selected LCD multiplex drive mode. [Table 36](#) describes which outputs are active for each of the multiplex drive modes and what signal is generated.

Table 36. Mapping of output pins and corresponding output signals with respect to the multiplex driving mode

Multiplex drive mode	Output pin			
	COM0	COM1	COM2	COM3
	Signal			
static	BP0	BP0	BP0	BP0
1:2	BP0	BP1	BP0	BP1
1:4	BP0	BP1	BP2	BP3

[Table 37](#) describes the corresponding layout topology.

Table 37. Layout topology of output pins and corresponding output signals with respect to the multiplex driving mode

Multiplex drive mode					
Static		1:2		1:4	
Signal	On pin	Signal	On pin	Signal	On pin
BP0	COM0	BP0	COM0	BP0	COM0
	COM1		COM2	BP1	COM1
	COM2	BP1	COM1	BP2	COM2
	COM3		COM3	BP3	COM3

8.11.1 Driving strength on the backplanes

Corresponding output pins (COMx), which are carrying the same signal (BPx), may optionally be connected to the display. This allows gaining a higher driving strength. If not required, the unused pins can be left open-circuit.

8.12 Segment outputs

The LCD drive section includes 102 segment outputs (S0 to S101) which must be connected directly to the LCD. The segment output signals are generated based on the multiplexed backplane signals and with data resident in the display register. When less than 102 segment outputs are required, the unused segment outputs must be left open-circuit.

8.13 Display register

The display register holds the display data while the corresponding multiplex signals are generated.

8.14 Display RAM

The display RAM is a static 102 × 4-bit RAM which stores LCD data. Logic 1 in the RAM bit map indicates the on-state, logic 0 the off-state of the corresponding LCD element.

There is a one-to-one correspondence between

- the bits in the RAM bitmap and the LCD segments/elements
- the RAM columns and the segment outputs
- the RAM rows and the backplane outputs.

The display RAM bit map, [Figure 29 on page 53](#), shows row 0 to row 3 which correspond with the backplane outputs COM0 to COM3, and column 0 to column 101 which correspond with the segment outputs S0 to S101. In multiplexed LCD applications, the data of each row of the display RAM is time-multiplexed with the corresponding backplane (row 0 with COM0, row 1 with COM1, and so on).

When display data is transmitted to the PCA8530, the display bytes received are stored in the display RAM in accordance with the selected LCD multiplex drive mode. The data is stored as it arrives and does not wait for the acknowledge cycle as with the commands. Depending on the current multiplex drive mode, data is stored singularly, in pairs, or quadruples.

8.14.1 Data pointer

The addressing mechanism for the display RAM is realized using a data pointer. This allows the loading of an individual display data byte, or a series of display data bytes into any location of the display RAM. The sequence commences with the initialization of the data pointer by the Data-pointer-init command followed by setting the data pointer with the Data-pointer-MSB and Data-pointer-LSB commands. Then the display RAM content can be written. An arriving data byte is stored starting at the display RAM address indicated by the data pointer.

The data pointer is automatically incremented in accordance with the chosen LCD multiplex drive mode configuration. After each byte is stored, the content of the data pointer is incremented

- by eight (static drive mode)
- by four (1:2 multiplex drive mode)
- by two (1:4 multiplex drive mode)

When the address counter reaches the end of the RAM, it stops incrementing after the last byte is transmitted. Redundant bits of the last byte and subsequent bytes transmitted are discarded. To send new RAM data, the data pointer must be reset.

If a data access with the I²C- or SPI-bus is terminated early, then the state of the data pointer is unknown. The data pointer must then be rewritten before further RAM accesses.

8.14.1.1 Data pointer in cascade configuration

In cascaded applications each PCA8530 in the cascade must be addressed separately. Initially, the first PCA8530 is selected by sending the Device-address command matching the first hardware address. Then the data pointer is set to the preferred display RAM address with the Data-pointer commands.

Storage is allowed only when the content of the device address register matches with the hardware device address applied to A0 and A1 (see [Section 8.2.3](#)). If the content of the device address register and the hardware device address do not match, then data storage is inhibited but the data pointer is incremented as if data storage had taken place.

8.14.2 RAM filling

For the following examples showing the RAM filling patterns, it is assumed that the bits shown in [Table 38](#) are transferred to the RAM.

Table 38. Bit scheme used to illustrate the RAM filling patterns

Bit	7	6	5	4	3	2	1	0
Byte	MSB							LSB
1	aa7	aa6	aa5	aa4	aa3	aa2	aa1	aa0
2	ab7	ab6	ab5	ab4	ab3	ab2	ab1	ab0
:	:	:	:	:	:	:	:	:
51	by7	by6	by5	by4	by3	by2	by1	by0

8.14.2.1 RAM filling in static drive mode

In the static drive mode, the eight transmitted data bits are placed in eight successive display RAM columns in row 0 (see [Table 39](#)).

Table 39. RAM filling in static drive mode

RAM row/ backplane output (COM)	RAM column/Segment output (S)																			
	0	1	2	3	4	5	6	7	8	9	10	11	12	13	14	15	:	99	100	101
0	aa7	aa6	aa5	aa4	aa3	aa2	aa1	aa0	ab7	ab6	ab5	ab4	ab3	ab2	ab1	ab0	:	am4	am3	am2
1	-	-	-	-	-	-	-	-	-	-	-	-	-	-	-	-	:	-	-	-
2	-	-	-	-	-	-	-	-	-	-	-	-	-	-	-	-	:	-	-	-
3	-	-	-	-	-	-	-	-	-	-	-	-	-	-	-	-	:	-	-	-

In order to fill the whole RAM row, 13 bytes must be sent to the PCA8530. Any data bits that spill over the RAM and additional data bytes sent are discarded.

8.14.2.2 RAM filling in 1:2 multiplex drive mode

In the 1:2 multiplex drive mode the eight transmitted data bits are placed in four successive display RAM columns of two rows (see [Table 40](#)).

Table 40. RAM filling in 1:2 multiplex drive mode

RAM row/ backplane output (COM)	RAM column/Segment output (S)											
	0	1	2	3	4	5	6	7	:	99	100	101
0	aa7	aa5	aa3	aa1	ab7	ab5	ab3	ab1	:	ay1	az7	az5
1	aa6	aa4	aa2	aa0	ab6	ab4	ab2	ab0	:	ay0	az6	az4
2	-	-	-	-	-	-	-	-	:	-	-	-
3	-	-	-	-	-	-	-	-	:	-	-	-

In order to fill the whole two RAM rows 26 bytes need to be sent to the PCA8530. Any data bits that spill over the RAM and additional data bytes sent are discarded.

8.14.2.3 RAM filling in 1:4 multiplex drive mode

In the 1:4 multiplex drive mode the eight transmitted data bits are placed in two successive display RAM columns of four rows (see [Table 41](#)).

Table 41. RAM filling in 1:4 multiplex drive mode

RAM row/ backplane output (COM)	RAM column/Segment output (S)							
	0	1	2	3	:	99	100	101
0	aa7	aa3	ab7	ab3	:	bx3	by7	by3
1	aa6	aa2	ab6	ab2	:	bx2	by6	by2
2	aa5	aa1	ab5	ab1	:	bx1	by5	by1
3	aa4	aa0	ab4	ab0		bx0	by4	by0

In order to fill the whole four RAM rows 51 bytes need to be sent to the PCA8530. Depending on the start address of the data pointer, there is the possibility for a boundary condition. This occurs when more data bits are sent than fit into the remaining RAM. The additional data bits are discarded.

8.14.3 Bank selection

The PCA8530 includes a RAM bank switching feature in the static and 1:2 multiplex drive modes. A bank can be thought of as a RAM row or a collection of RAM rows. The RAM bank switching gives the provision for preparing display information in an alternative bank and to be able to switch to it once it is complete. [Figure 29](#) shows the location of the banks relative to the RAM map.

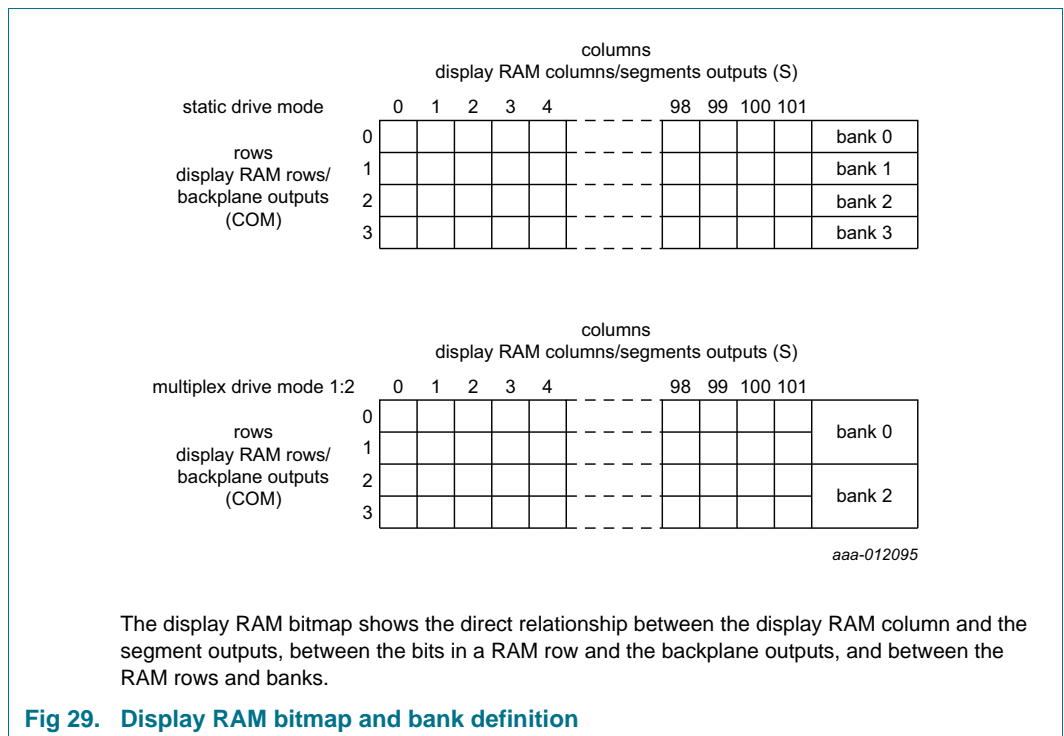
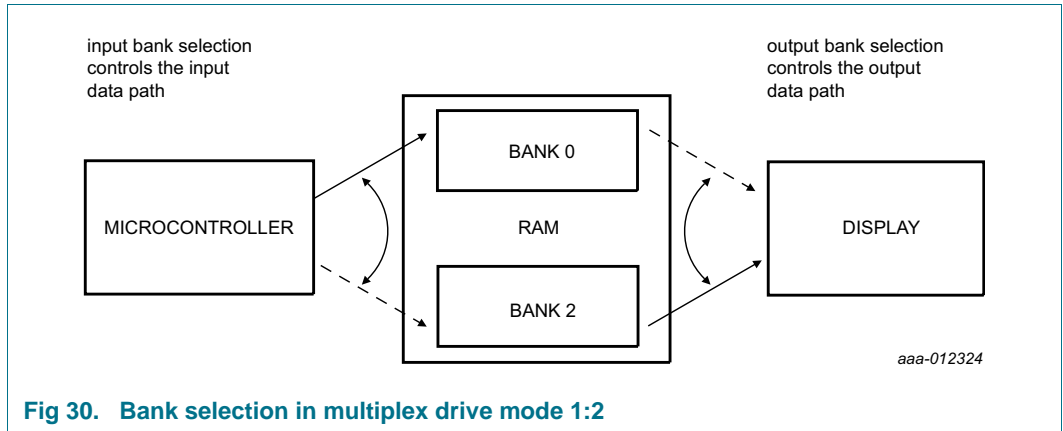

Fig 29. Display RAM bitmap and bank definition

Input and output banks can be set independently from one another with the bank-select commands (see [Section 8.7.2 on page 24](#)). [Figure 31](#) shows the concept.



In the 1:2 multiplex mode, the bank-select command may request the contents of bank 2 to be selected for display instead of the contents of bank 0. This gives the provision for preparing display information in an alternative bank and to be able to switch to it once it is assembled.

In [Figure 31](#) an example is shown for 1:2 multiplex drive mode where the displayed data is read from the first two rows of the memory (bank 0), while the transmitted data is stored in the second two rows of the memory (bank 1).

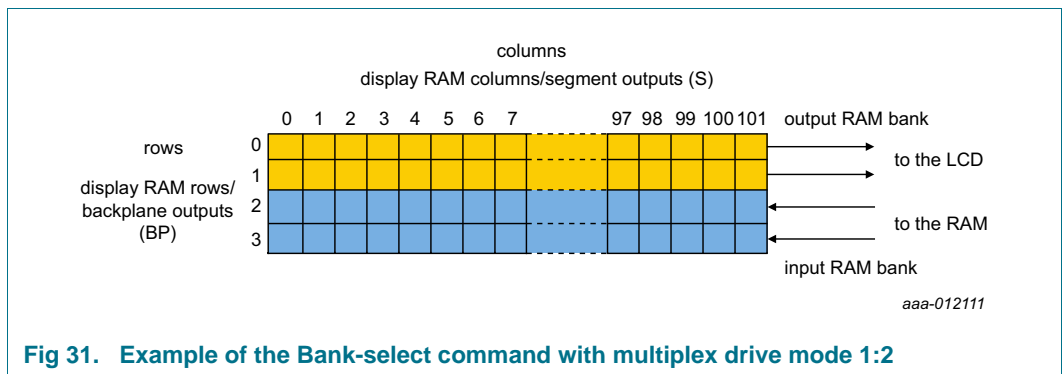

8.14.3.1 Input-bank-select

The Input-bank-select command (see [Table 26 on page 24](#)) loads display data into the display RAM in accordance with the selected LCD drive configuration (see [Figure 29 on page 53](#)).

- In static drive mode, an individual content can be stored in each RAM bank (bank 0 to bank 3 which corresponds to row 0 and row 3).
- In 1:2 multiplex drive mode, individual content for RAM bank 0 (row 0 and row 1), RAM bank 2 (row 2 and row 3) can be stored.

The Input-bank-select command works independently to the Output-bank-select command.

8.14.3.2 Output-bank-select

The Output-bank-select command (see [Table 27 on page 25](#)) selects the display RAM transferring it to the display register in accordance with the selected LCD drive configuration (see [Figure 29 on page 53](#)).

- In the static drive mode, it is possible to request the content of RAM bank 1 for display instead of the default RAM bank 0.
- In 1:2 multiplex drive mode, the content of RAM bank 2 may be selected instead of the default RAM bank 0.

The Output-bank-select command works independently to the Input-bank-select command.

9. Bus interfaces

9.1 Control byte and register selection

After initiating the communication over the bus and sending the slave address (I²C-bus, see [Section 9.2](#)) or subaddress (SPI-bus, see [Section 9.3 on page 61](#)), a control byte follows. The purpose of this byte is to indicate both, the content for the following data bytes (RAM or command) and to indicate that more control bytes will follow.

Typical sequences could be:

- Slave address/subaddress - control byte - command byte - command byte - command byte - end
- Slave address/subaddress - control byte - RAM byte - RAM byte - RAM byte - end
- Slave address/subaddress - control byte - command byte - control byte - RAM byte - end

This allows sending a mixture of RAM and command data in one access or alternatively, to send just one type of data in one access. In this way, it is possible to configure the device and then fill the display RAM with little overhead. The display bytes are stored in the display RAM at the address specified by the data pointer.

Table 42. Control byte description

Bit	Symbol	Value	Description
7	CO		continue bit
		0	last control byte
		1	control bytes continue
6 to 5	RS[1:0]		register selection
		00, 10	command register
		01	RAM data
		11	unused
4 to 0	-	-	unused

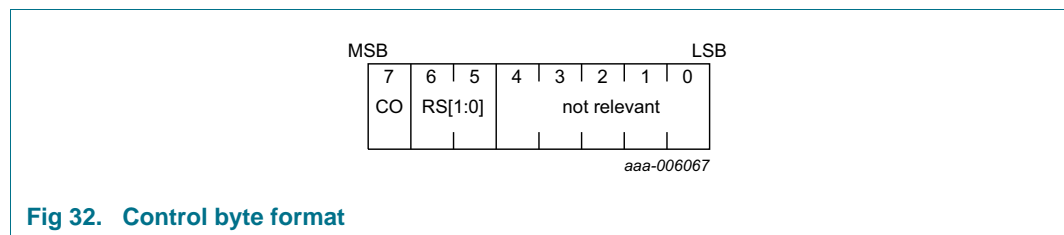

Fig 32. Control byte format

9.2 I²C interface

The I²C-bus is selected by connecting pin IFS to V_{DD1}.

The I²C-bus is for bidirectional, two-line communication between different ICs or modules. The two lines are a Serial DATA line (SDA) and a Serial CLOCK line (SCL). Both lines must be connected to a positive supply via a pull-up resistor when connected to the output stages of a device. Data transfer may be initiated only when the bus is not busy.

In Chip-On-Glass (COG) applications, where the track resistance between the SDA output pin to the system SDA input line can be significant, the bus pull-up resistor and the Indium Tin Oxide (ITO) track resistance may generate a voltage divider. As a consequence it may be possible that the acknowledge cycle, generated by the LCD driver, cannot be interpreted as logic 0 by the master. Therefore it is an advantage for COG applications to have the acknowledge output separated from the data line. For that reason, the SDA line of the PCA8530 is split into SDI/SDAIN and SDAOUT.

In COG applications where the acknowledge cycle is required, it is necessary to minimize the track resistance from the SDAOUT pin to the system SDI/SDAIN line to guarantee a valid LOW level.

By splitting the SDA line into SDI/SDAIN and SDAOUT (having the SDAOUT open circuit), the device could be used in a mode that ignores the acknowledge cycle. Separating the acknowledge output from the serial data line can avoid design efforts to generate a valid acknowledge level. However, in that case the I²C-bus master has to be set up in such a way that it ignores the acknowledge cycle.²

By connecting pin SDAOUT to pin SDI/SDAIN, the SDI/SDAIN line becomes fully I²C-bus compatible. The following definition assumes SDI/SDAIN and SDAOUT are connected and refers to the pair as SDA.

9.2.1 Bit transfer

One data bit is transferred during each clock pulse. The data on the SDA line must remain stable during the HIGH period of the clock pulse as changes in the data line at this time are interpreted as a control signal (see [Figure 33](#)).

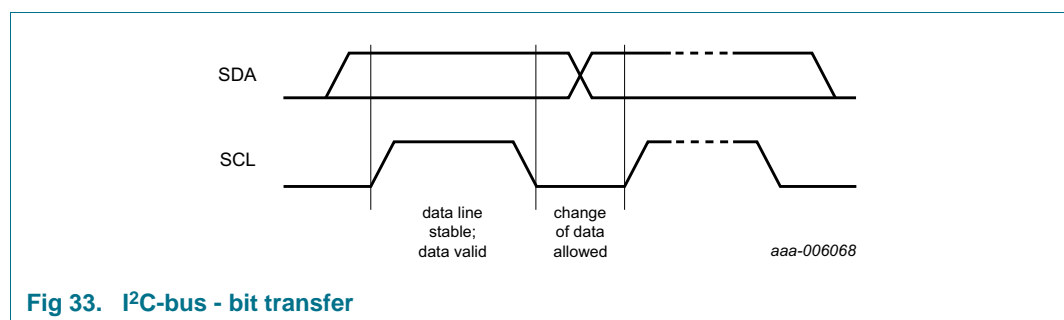

Fig 33. I²C-bus - bit transfer

9.2.2 START and STOP conditions

Both data and clock lines remain HIGH when the bus is not busy.

A HIGH-to-LOW change of the data line, while the clock is HIGH is defined as the START condition (S).

2. For further information, consider the NXP application note: [Ref. 1 "AN10170"](#).

A LOW-to-HIGH change of the data line while the clock is HIGH is defined as the STOP condition (P).

The START and STOP conditions are shown in [Figure 34](#).

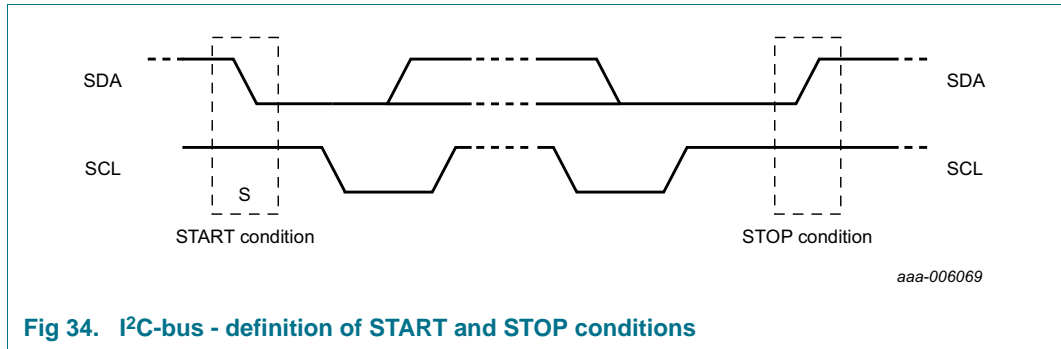

Fig 34. I²C-bus - definition of START and STOP conditions

9.2.3 System configuration

A device generating a message is a transmitter; a device receiving a message is the receiver. The device that controls the message is the master; and the devices which are controlled by the master are the slaves. The system configuration is shown in [Figure 35](#).

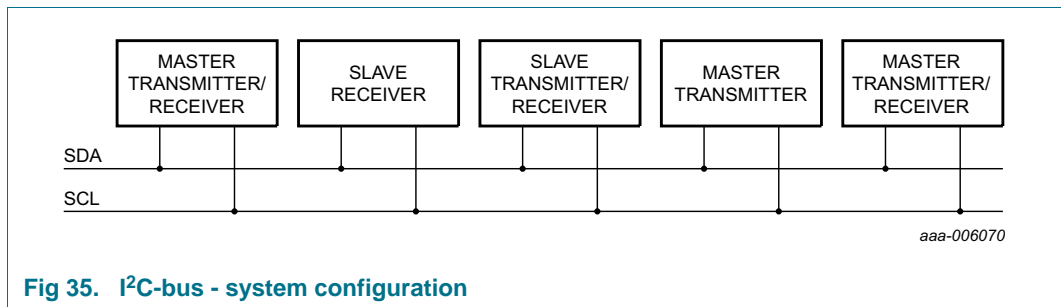

Fig 35. I²C-bus - system configuration

9.2.4 Acknowledge

The number of data bytes transferred between the START and STOP conditions from transmitter to receiver is unlimited. Each byte of 8 bits is followed by an acknowledge cycle.

- A slave receiver which is addressed must generate an acknowledge after the reception of each byte.
- Also a master receiver must generate an acknowledge after the reception of each byte that has been clocked out of the slave transmitter.
- The device that acknowledges must pull-down the SDA line during the acknowledge clock pulse, so that the SDA line is stable LOW during the HIGH period of the acknowledge related clock pulse (set-up and hold times must be considered).
- A master receiver must signal an end of data to the transmitter by not generating an acknowledge on the last byte that has been clocked out of the slave. In this event, the transmitter must leave the data line HIGH to enable the master to generate a STOP condition.

Acknowledgement on the I²C-bus is shown in [Figure 36](#).

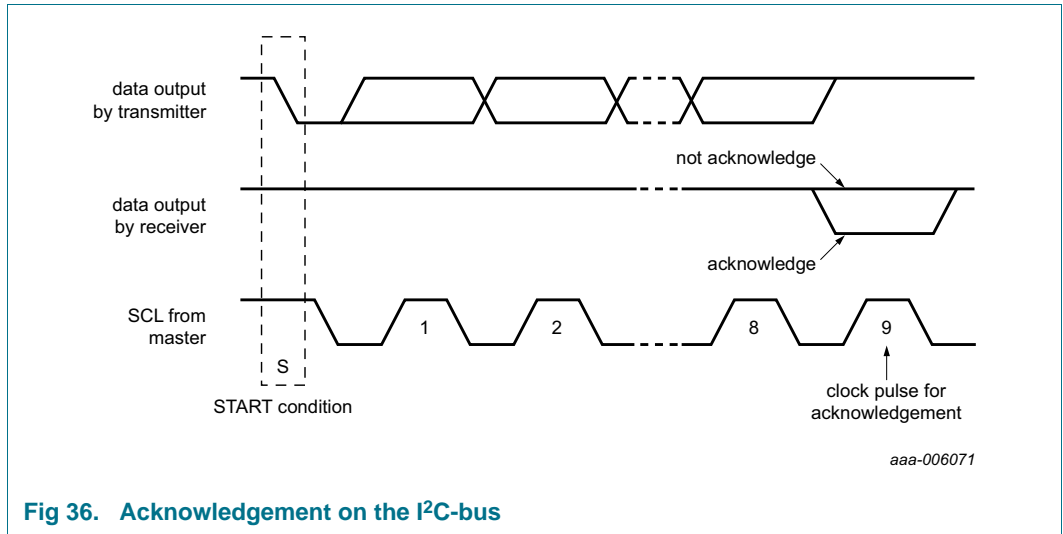

Fig 36. Acknowledgement on the I²C-bus

9.2.5 I²C-bus controller

The PCA8530 acts as an I²C-bus slave receiver. It does not initiate I²C-bus transfers. The only data output from PCA8530 is the acknowledge signals and the temperature readout byte of the selected device.

9.2.6 Input filters

To enhance noise immunity in electrically adverse environments, RC low-pass filters are provided on the SDA and SCL lines.

9.2.7 I²C-bus slave address

Device selection depends on the I²C-bus slave address.

Table 43. I²C slave address byte

Bit	Slave address							0 LSB
	7 MSB	6	5	4	3	2	1	
slave address	0	1	1	1	0	SA1	SA0	R/W

The least significant bit of the slave address byte is bit R/W (see Table 44).

Table 44. R/W-bit description

R/W	Description
0	write data
1	read data

Bit 1 and bit 2 of the slave address are defined by connecting the inputs SA0 and SA1 to either V_{SS1} (logic 0) or V_{DD1} (logic 1). Therefore, four instances of PCA8530 can be distinguished on the same I²C-bus.

9.2.8 I²C-bus protocol

The I²C-bus protocol is shown in Figure 37. The sequence is initiated with a START condition (S) from the I²C-bus master which is followed by one of the four PCA8530 slave addresses available. All PCA8530 with the corresponding SA1 and SA0 level acknowledge in parallel to the slave address, but all PCA8530 with the alternative SA1 and SA0 levels ignore the whole I²C-bus transfer.

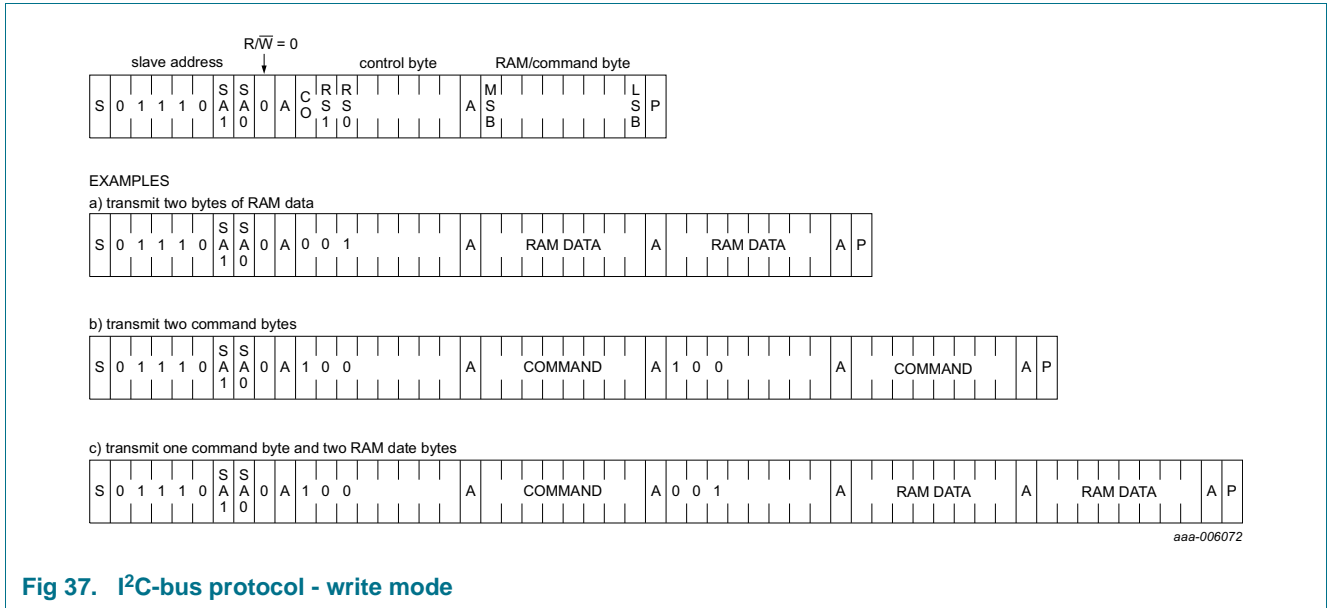
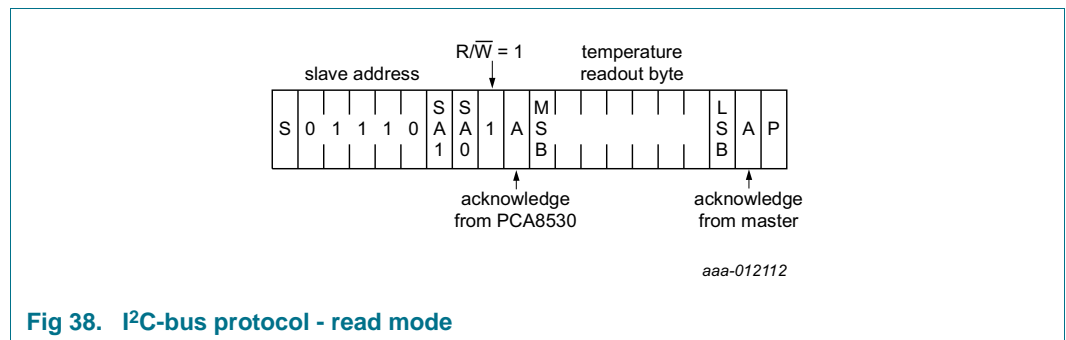

Fig 37. I²C-bus protocol - write mode

After acknowledgement, a control byte follows which defines if the next byte is RAM or command information. The control byte (see Table 42 on page 56) also defines whether the next byte is a control byte or further RAM or command data.

For a temperature readout (see Section 8.10.4.1 on page 40), the R/W bit must be logic 1. The next data byte following is provided by the PCA8530 as shown in Figure 38.



9.3 SPI interface

The SPI interface is selected by connecting pin IFS to V_{SS1} .

Data transfer to the device is made via a four-line SPI-bus (see [Table 45](#)). The SPI-bus is initialized whenever the chip enable line pin \overline{CE} is LOW.

Table 45. Serial interface

Symbol	Function	Description
\overline{CE}	chip enable input; active LOW ^[1]	when HIGH, the interface is reset
SCL	serial clock input	input may be higher than V_{DD1}
SDI/SDAIN	serial data input	input may be higher than V_{DD1} ; input data is sampled on the rising edge of SCL
SDO	serial data output	-

[1] The chip enable must not be wired permanently LOW.

9.3.1 Data transmission

The chip enable signal (\overline{CE}) is used to initialize data transmission. Each data transfer is a byte, with the MSB sent first. The first byte transmitted is the subaddress byte.

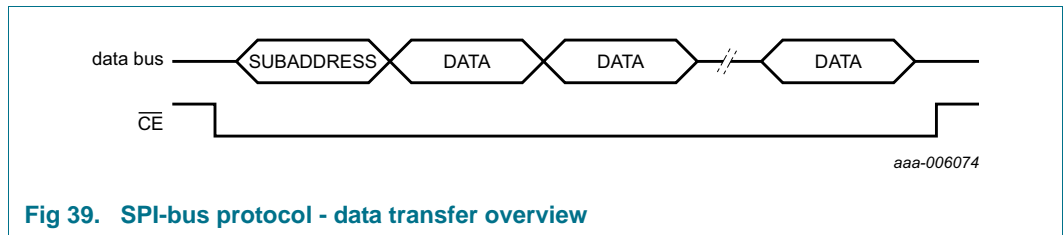

Fig 39. SPI-bus protocol - data transfer overview

The subaddress byte opens the communication with a read/write bit and a subaddress. The subaddress is used to identify multiple devices on one SPI bus.

Table 46. Subaddress byte definition

Bit	Symbol	Value	Description
7	R/\overline{W}		data read or write selection
		0	write data
		1	read data
6 to 5	SA	01	subaddress ; other codes cause the device to ignore data transfer
4 to 0	-		unused

[Figure 40](#) shows an example of an SPI data transfer.

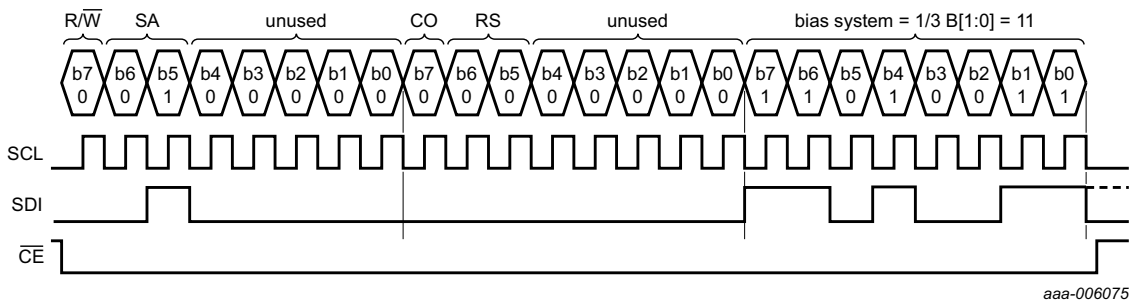

In this example, the bias system is set to 1/3. The transfer is terminated by \overline{CE} returning to logic 1. After the last bit is transmitted, the state of the SDI/SDAIN line is not important.

Fig 40. SPI-bus example

For a temperature readout (see [Section 8.10.4.1 on page 40](#)), the R/\overline{W} bit must be logic 1. The next data byte following is provided by the PCA8530 as shown in [Figure 41](#).

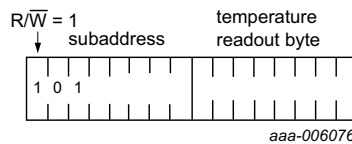
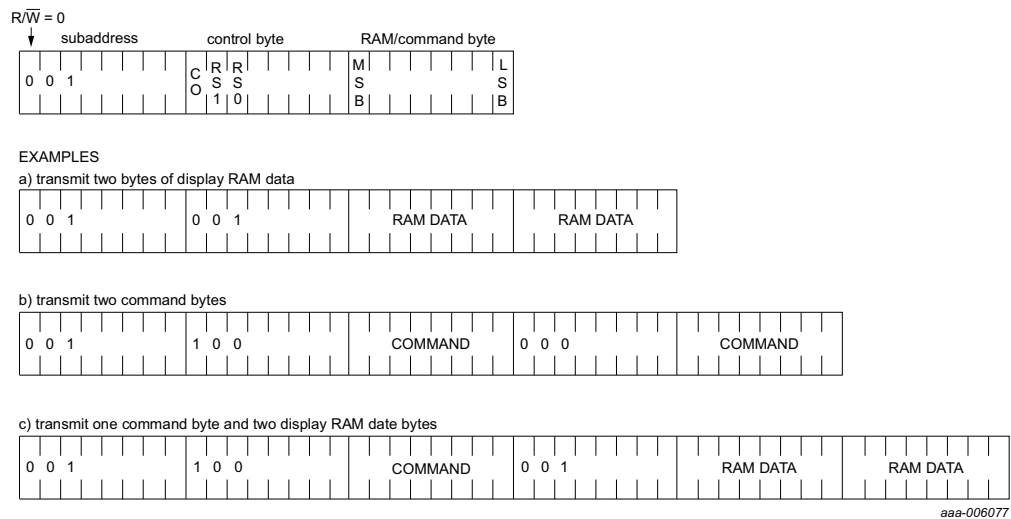

Fig 41. SPI-bus protocol - read example



Data transfers are terminated by de-asserting \overline{CE} (set \overline{CE} to logic 1).

Fig 42. SPI-bus protocol - write example

10. Internal circuitry

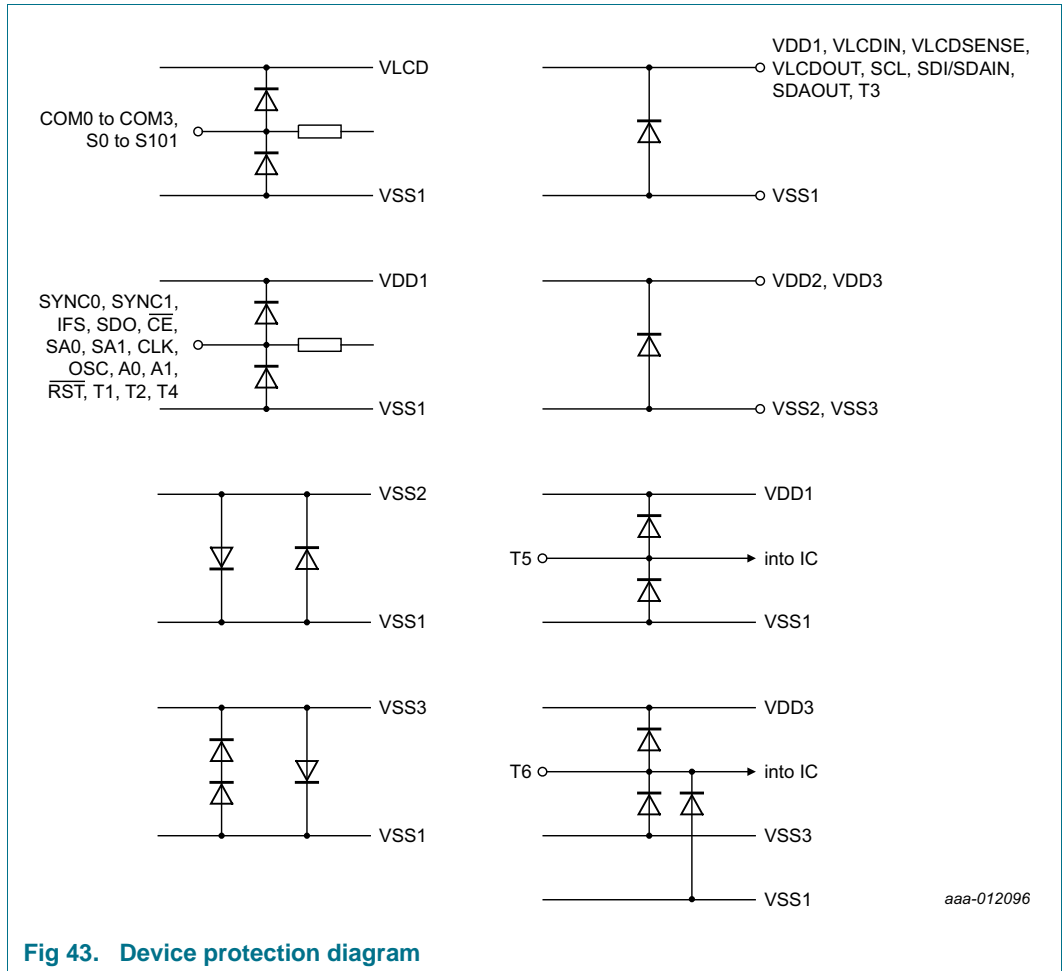

Fig 43. Device protection diagram

11. Safety notes

CAUTION



This device is sensitive to ElectroStatic Discharge (ESD). Observe precautions for handling electrostatic sensitive devices.

Such precautions are described in the *ANSI/ESD S20.20*, *IEC/ST 61340-5*, *JESD625-A* or equivalent standards.

CAUTION



Static voltages across the liquid crystal display can build up when the LCD supply voltage (V_{LCD}) is on while the IC supply voltage (V_{DD}) is off, or vice versa. This may cause unwanted display artifacts. To avoid such artifacts, V_{LCD} and V_{DD} must be applied or removed together.

CAUTION



Semiconductors are light sensitive. Exposure to light sources can cause the IC to malfunction. The IC must be protected against light. The protection must be applied to all sides of the IC.

12. Limiting values

Table 47. Limiting values
In accordance with the Absolute Maximum Rating System (IEC 60134).

Symbol	Parameter	Conditions	Min	Max	Unit	
V _{DD1}	supply voltage 1	analog and digital	-0.5	+6.5	V	
V _{DD2}	supply voltage 2	charge pump	-0.5	+6.5	V	
V _{DD3}	supply voltage 3	analog	-0.5	+6.5	V	
I _{DD1}	supply current 1	analog and digital	-50	+50	mA	
I _{DD2}	supply current 2	charge pump	-50	+50	mA	
I _{DD3}	supply current 3	analog	-50	+50	mA	
V _{LCD}	LCD supply voltage	external supply, input on pin VLCDIN	-0.5	+20	V	
I _{DD(LCD)}	LCD supply current		-50	+50	mA	
V _i	input voltage	on pins CLK, OSC, A0, A1, RST, IFS, SCL, SDI/SDAIN, SA0, CE, SA1, SYNC0, SYNC1	-0.5	+6.5	V	
		on pin VLCDSENSE	-0.5	+20	V	
I _I	input current		-10	+10	mA	
V _O	output voltage	on pins S0 to S101, COM0 to COM3, VLCDOUT	-0.5	+20	V	
		on pins SDO, SA0, SDAOUT, CLK, SYNC0, SYNC1	-0.5	+6.5	V	
I _O	output current		-10	+10	mA	
I _{SS}	ground supply current		-50	+50	mA	
P _{tot}	total power dissipation		-	400	mW	
P/out	power dissipation per output		-	100	mW	
V _{ESD}	electrostatic discharge voltage	HBM	[1]	±2000	V	
I _{lu}	latch-up current		[2]	150	mA	
T _{stg}	storage temperature		[3]	-65	+150	°C
T _{amb}	ambient temperature	operating device	-40	+105	°C	

[1] Pass level; Human Body Model (HBM), according to [Ref. 8 "JESD22-A114"](#).

[2] Pass level; latch-up testing according to [Ref. 9 "JESD78"](#) at maximum ambient temperature (T_{amb(max)}).

[3] According to the store and transport requirements (see [Ref. 14 "UM10569"](#)) the devices have to be stored at a temperature of +8 °C to +45 °C and a humidity of 25 % to 75 %.

13. Static characteristics

Table 48. Static characteristics
 $V_{DD1}, V_{DD2}, V_{DD3} = 2.5 \text{ V to } 5.5 \text{ V}; V_{SS1} = 0 \text{ V}; V_{LCD} = 4.0 \text{ V to } 12.0 \text{ V}; T_{amb} = -40 \text{ }^\circ\text{C to } +105 \text{ }^\circ\text{C};$ unless otherwise specified.

Symbol	Parameter	Conditions	Min	Typ	Max	Unit
Supplies						
V_{DD1}	supply voltage 1		2.5	-	5.5	V
V_{DD2}	supply voltage 2		2.5	-	5.5	V
V_{DD3}	supply voltage 3		2.5	-	5.5	V
V_{LCD}	LCD supply voltage	$V_{LCD} \geq V_{DD2}$				
		external supply, input on pin VLCDIN	4.0	-	12.0	V
		internal supply, output on pin VLCDOUT	4.0	-	12.0	V
I_{DD1}	supply current 1	on pin VDD1				
		default condition after power-on and Initialize command, see Figure 44	-	40 ^[1]	58 ^[2]	μA
		display enabled; internal clock	-	45 ^[1]	-	μA
I_{DD2}	supply current 2	on pin VDD2				
		default condition after power-on and Initialize command	-	0	-	μA
		$V_{DD2} = 5 \text{ V};$ charge pump at $V_{LCD} = 2 \times V_{DD2};$ $V_{LCD} = 8 \text{ V};$ $C_{VLCD} = 100 \text{ nF};$ display disabled; see Figure 45	-	25	-	μA
I_{DD3}	supply current 3	on pin VDD3				
		default condition after power-on and Initialize command, see Figure 46	-	40 ^[3]	58 ^[4]	μA
		display enabled; internal clock	-	90 ^[3]	-	μA
$I_{DD(LCD)}$	LCD supply current	on pin VLCDIN; external $V_{LCD} = 8 \text{ V}$				
		display disabled, see Figure 47	-	6.5	10	μA
		MUX 1:4; $\frac{1}{3}$ bias; $f_{fr} = 80 \text{ Hz};$ RAM entirely filled with 1; frame inversion mode; display enabled; no display attached	-	85	-	μA

Table 48. Static characteristics ...continued

$V_{DD1}, V_{DD2}, V_{DD3} = 2.5\text{ V to }5.5\text{ V}; V_{SS1} = 0\text{ V}; V_{LCD} = 4.0\text{ V to }12.0\text{ V}; T_{amb} = -40\text{ }^{\circ}\text{C to }+105\text{ }^{\circ}\text{C};$ unless otherwise specified.

Symbol	Parameter	Conditions	Min	Typ	Max	Unit
Accuracy						
ΔV_{LCD}	LCD voltage variation	on pin VLCDOUT; internal V_{LCD} ; $V[8:0] = 86h$; $T_{amb} = 25\text{ }^{\circ}\text{C}$; see Figure 48	7950	8010	8070	mV
Δf_{fr}	frame frequency variation	internal clock; $FF[4:0] = 00111$; $T_{amb} = 25\text{ }^{\circ}\text{C}$; see Figure 49	77	80	83	Hz
ΔT_{meas}	measurement temperature variation	see Figure 50	-	± 0	-	$^{\circ}\text{C}$
Output resistance						
$R_{o(COM[0:8])}$	output resistance on pin COM0 to COM3	external $V_{LCD} = 8\text{ V}$	-	1	-	k Ω
$R_{o(S[0:101])}$	output resistance on pin S0 to S101	external $V_{LCD} = 8\text{ V}$	-	2.5	-	k Ω
Logic						
On pins CLK, OSC, A0, A1, SYNC0, SYNC1, \overline{RST} , IFS						
V_I	input voltage		$V_{SS1} - 0.5$	-	$V_{DD1} + 0.5$	V
V_{IL}	LOW-level input voltage		-	-	$0.3V_{DD1}$	V
V_{IH}	HIGH-level input voltage		$0.7V_{DD1}$	-	-	V
I_{LI}	input leakage current	$V_I = V_{DD1}$ or V_{SS1}	-	0	-	μA
On pins CLK, SYNC0, SYNC1						
V_O	output voltage		-0.5	-	$V_{DD1} + 0.5$	V
V_{OH}	HIGH-level output voltage		$0.8V_{DD1}$	-	-	V
V_{OL}	LOW-level output voltage		-	-	$0.2V_{DD1}$	V
I_{OH}	HIGH-level output current	output source current; $V_{OH} = 4.6\text{ V}$; $V_{DD1} = 5\text{ V}$	1	-	-	mA
I_{OL}	LOW-level output current	output sink current; $V_{OL} = 0.4\text{ V}$; $V_{DD1} = 5\text{ V}$	1	-	-	mA
I_{LO}	output leakage current	$V_O = V_{DD1}$ or V_{SS1}	-	0	-	μA
I²C-bus						
On pins SCL, SDI/SDAIN						
V_I	input voltage		$V_{SS1} - 0.5$	-	5.5	V
V_{IL}	LOW-level input voltage		-	-	$0.3V_{DD1}$	V
V_{IH}	HIGH-level input voltage		$0.7V_{DD1}$	-	-	V
I_{LI}	input leakage current	$V_I = V_{DD1}$ or V_{SS1}	-	0	-	μA
On pin SDAOUT						
V_O	output voltage		-0.5	-	+5.5	V
I_{OL}	LOW-level output current	output sink current; $V_{OL} = 0.4\text{ V}$	6	-	-	mA

Table 48. Static characteristics ...continued

V_{DD1} , V_{DD2} , V_{DD3} = 2.5 V to 5.5 V; V_{SS1} = 0 V; V_{LCD} = 4.0 V to 12.0 V; T_{amb} = -40 °C to +105 °C; unless otherwise specified.

Symbol	Parameter	Conditions	Min	Typ	Max	Unit
I_{LI}	input leakage current	$V_I = V_{DD1}$ or V_{SS1}	-	0	-	μA
I_{LO}	output leakage current	$V_O = V_{SS1}$	-	0	-	μA
SPI-bus						
On pins SCL, SDI/SDAIN, $\overline{\text{CE}}$						
V_I	input voltage	on pins SCL, SDI/SDAIN	$V_{SS1} - 0.5$	-	5.5	V
		on pin $\overline{\text{CE}}$	$V_{SS1} - 0.5$	-	$V_{DD1} + 0.5$	V
V_{IL}	LOW-level input voltage		-	-	$0.3V_{DD1}$	V
V_{IH}	HIGH-level input voltage		$0.7V_{DD1}$	-	-	V
I_{LI}	input leakage current	$V_I = V_{DD1}$ or V_{SS1}	-	0	-	μA
On pin SDO						
V_O	output voltage		-0.5	-	$V_{DD1} + 0.5$	V
V_{OH}	HIGH-level output voltage		$0.8V_{DD1}$	-	-	V
V_{OL}	LOW-level output voltage		-	-	$0.2V_{DD1}$	V
I_{OH}	HIGH-level output current	output source current; $V_{OH} = 4.6$ V; $V_{DD1} = 5$ V	1	-	-	mA
I_{OL}	LOW-level output current	output sink current; $V_{OL} = 0.4$ V; $V_{DD1} = 5$ V	1	-	-	mA
I_{LO}	output leakage current	$V_O = V_{DD1}$ or V_{SS1}	-	0	-	μA

[1] $V_{DD1} = 5$ V; $T_{amb} = 25$ °C.

[2] $V_{DD1} = 5.5$ V; $T_{amb} = 105$ °C.

[3] $V_{DD3} = 5$ V; $T_{amb} = 25$ °C.

[4] $V_{DD3} = 5.5$ V; $T_{amb} = 105$ °C.

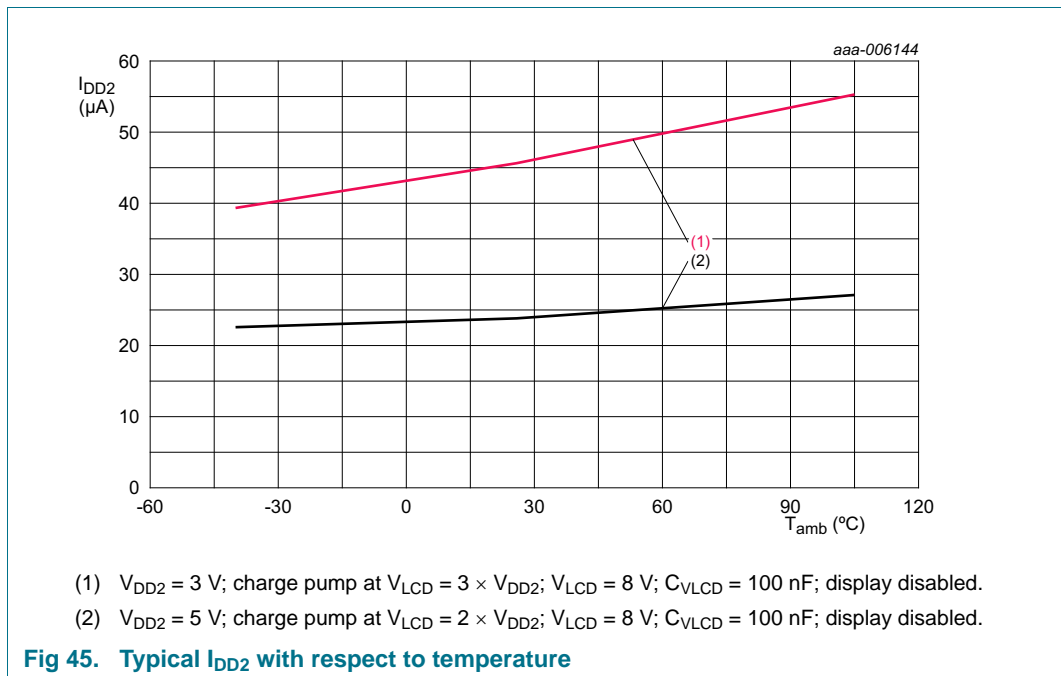
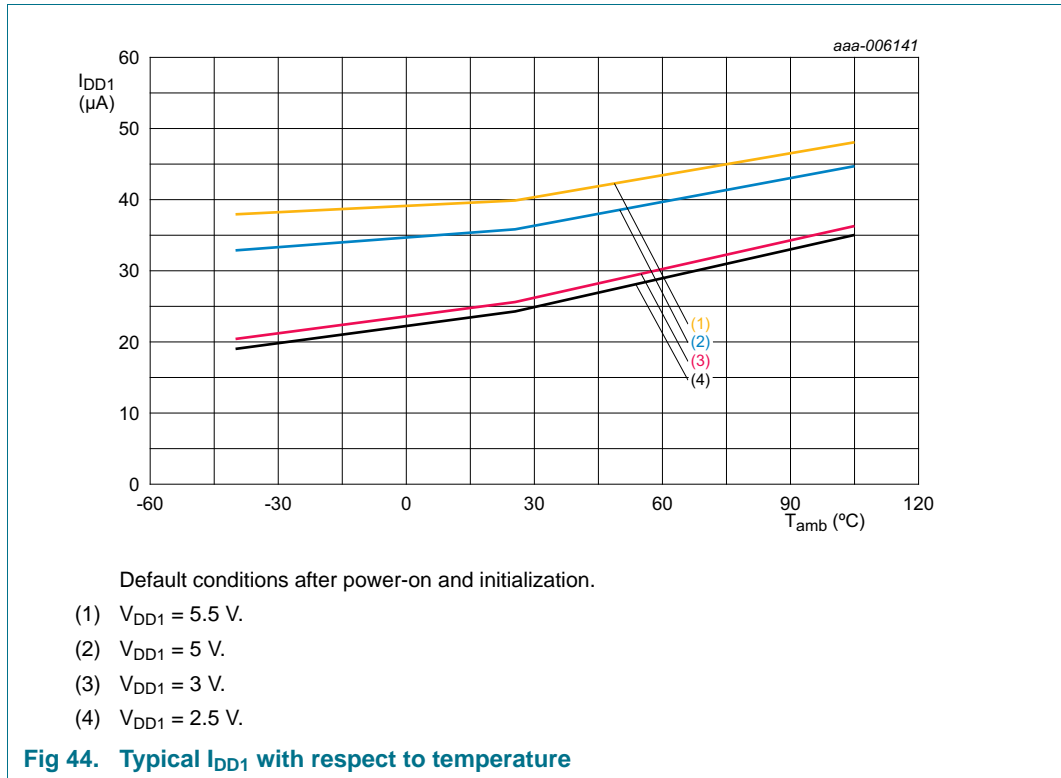

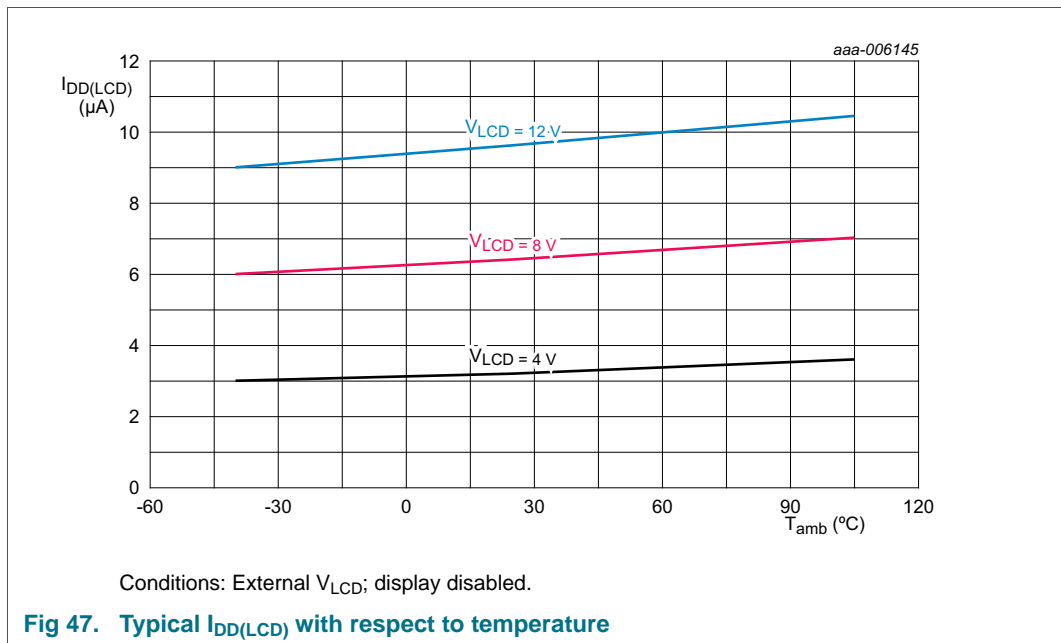
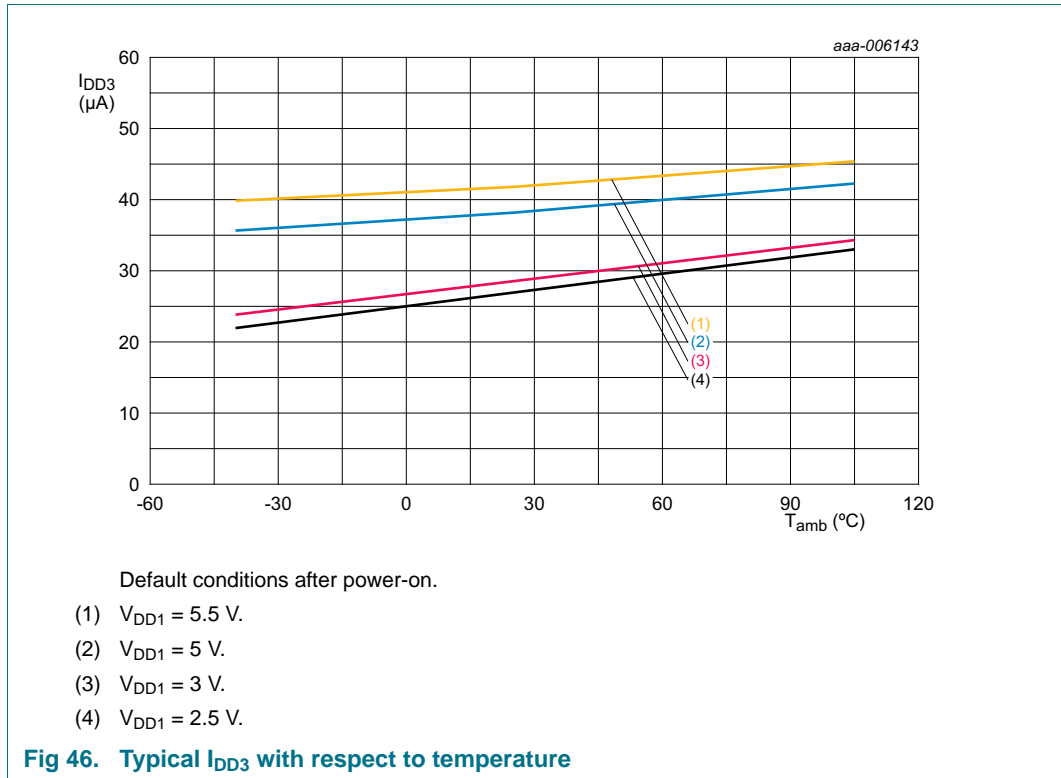

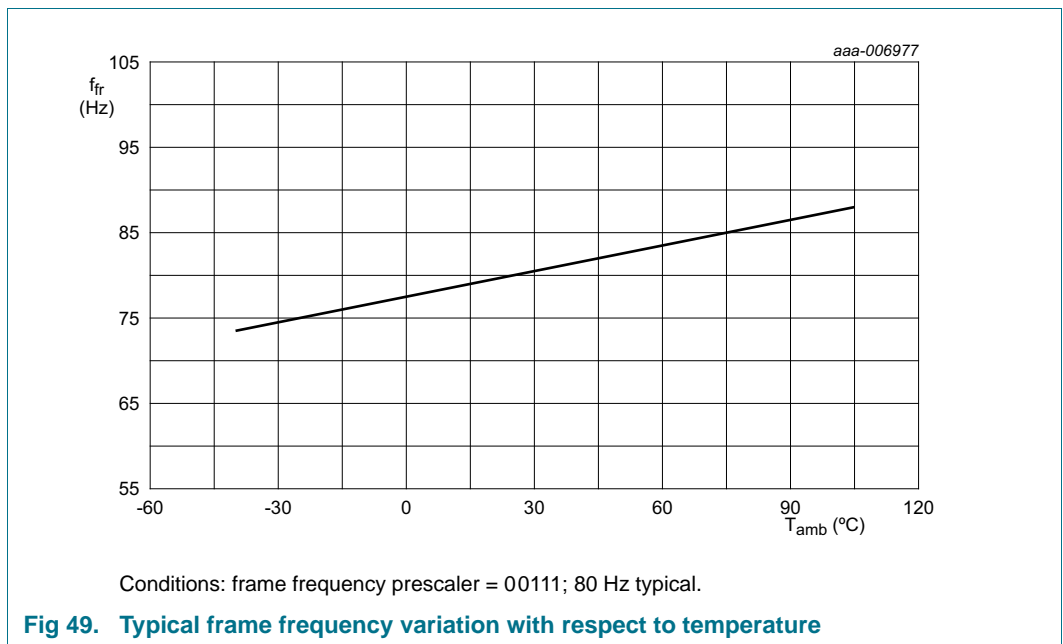
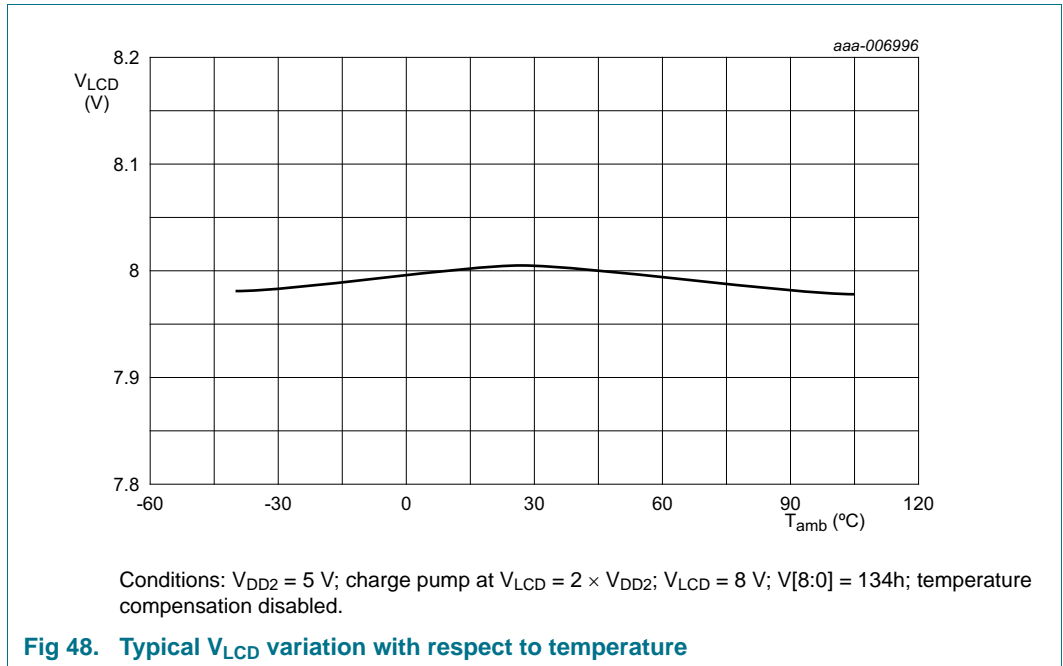

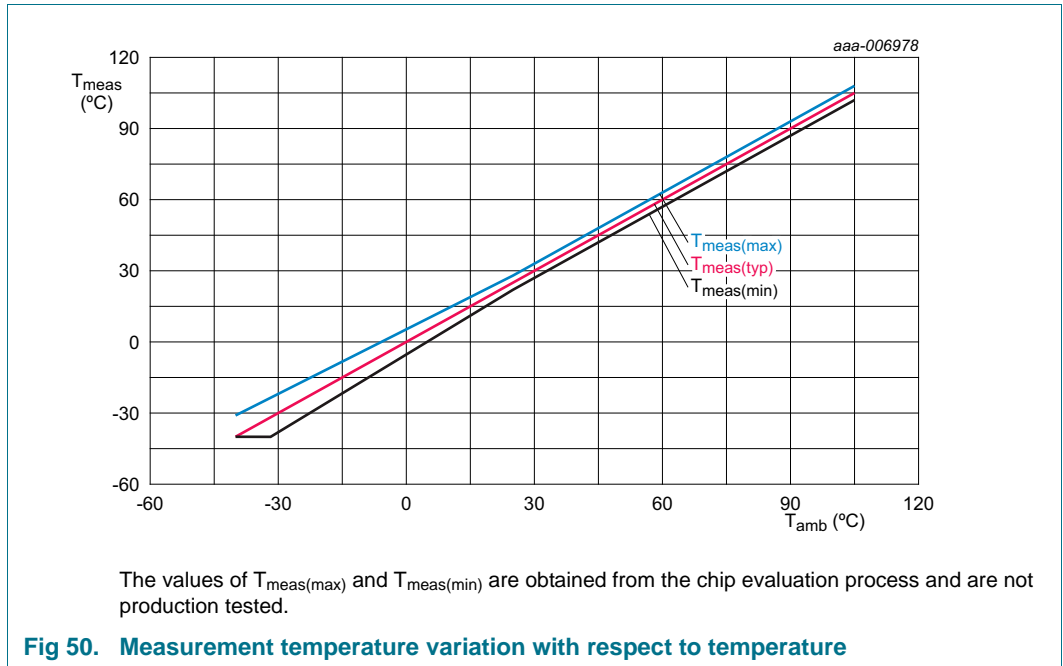

14. Dynamic characteristics

14.1 General dynamic characteristics

Table 49. General dynamic characteristics

V_{DD1} , V_{DD2} , $V_{DD3} = 2.5\text{ V to }5.5\text{ V}$; $V_{SS1} = 0\text{ V}$; $V_{LCD} = 4.0\text{ V to }12.0\text{ V}$; $T_{amb} = -40\text{ °C to }+105\text{ °C}$; unless otherwise specified. All timing values are valid within the operating supply voltage and ambient temperature range and are referenced to V_{IL} and V_{IH} with an input voltage swing of V_{SS1} to V_{DD1} .

Symbol	Parameter	Conditions	Min	Typ	Max	Unit
$f_{clk(int)}$	internal clock frequency	on pin CLK; FF[4:0] = 00111; $T_{amb} = 25\text{ °C}$	11 088	11 520	11 952	Hz
$f_{clk(ext)}$	external clock frequency	on pin CLK	6400	-	42 700	Hz
$t_{clk(H)}$	HIGH-level clock time	external clock source used	5	-	-	μs
$t_{clk(L)}$	LOW-level clock time		5	-	-	μs
$t_{wL(RST_N)}$	RST_N LOW pulse width		3	-	-	μs
C_b	capacitive load for each bus line	I ² C-bus	-	-	400	pF

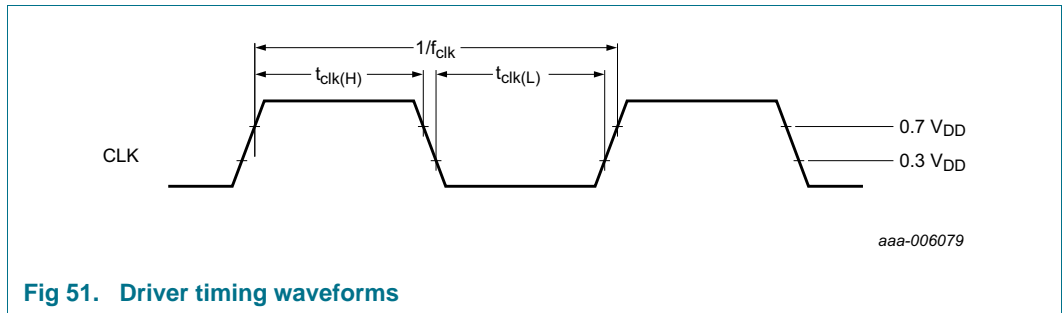

14.2 I²C-bus timing characteristics

Table 50. I²C-bus timing characteristic

V_{DD1} , V_{DD2} , $V_{DD3} = 2.5\text{ V to }5.5\text{ V}$; $V_{SS1} = 0\text{ V}$; $V_{LCD} = 4.0\text{ V to }12.0\text{ V}$; $T_{amb} = -40\text{ °C to }+105\text{ °C}$; unless otherwise specified. All timing values are valid within the operating supply voltage and ambient temperature range and are referenced to V_{IL} and V_{IH} with an input voltage swing of V_{SS1} to V_{DD1} .

Symbol	Parameter	Conditions	Min	Typ	Max	Unit
f _{SCL}	SCL frequency		-	-	400	kHz
t _{BUF}	bus free time between a STOP and START condition		1.3	-	-	μs
t _{HD;STA}	hold time (repeated) START condition		0.6	-	-	μs
t _{SU;STA}	set-up time for a repeated START condition		0.6	-	-	μs
t _{VD;DAT}	data valid time		[1]	-	0.9	μs
t _{VD;ACK}	data valid acknowledge time		[2]	-	0.9	μs
t _{LOW}	LOW period of the SCL clock		1.3	-	-	μs
t _{HIGH}	HIGH period of the SCL clock		0.6	-	-	μs
t _f	fall time	of both SDA and SCL signals	-	-	0.3	μs
t _r	rise time	of both SDA and SCL signals	-	-	0.3	μs
t _{SU;DAT}	data set-up time		100	-	-	ns
t _{HD;DAT}	data hold time		0	-	-	ns
t _{SU;STO}	set-up time for STOP condition		0.6	-	-	μs
t _{w(spike)}	spike pulse width		-	-	50	ns

[1] t_{VD;DAT} = minimum time for valid SDA output following SCL LOW.

[2] t_{VD;ACK} = time for acknowledgement signal from SCL LOW to SDA output LOW.

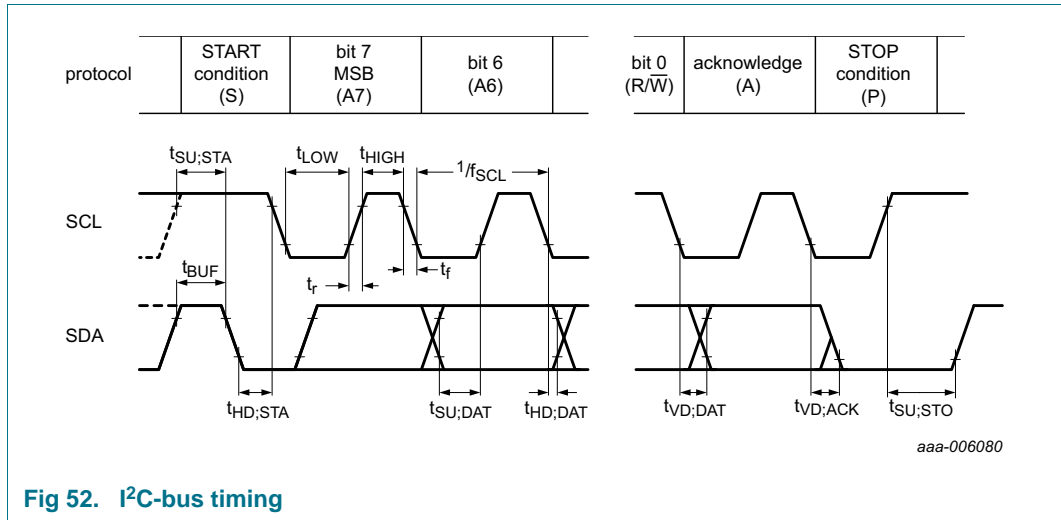

Fig 52. I²C-bus timing

14.3 SPI-bus timing characteristics

Table 51. SPI-bus timing characteristics

$V_{DD1}, V_{DD2}, V_{DD3} = 2.5\text{ V to }5.5\text{ V}; V_{SS1} = 0\text{ V}; V_{LCD} = 4.0\text{ V to }12.0\text{ V}; T_{amb} = -40\text{ }^{\circ}\text{C to }+105\text{ }^{\circ}\text{C};$ unless otherwise specified. All timing values are valid within the operating supply voltage and ambient temperature range and are referenced to V_{IL} and V_{IH} with an input voltage swing of V_{SS1} to V_{DD1} .

Symbol	Parameter	Conditions	Min	Max	Unit
Pin SCL					
$f_{clk(SCL)}$	SCL clock frequency		-	3.0	MHz
t_{SCL}	SCL time		333	-	ns
$t_{clk(H)}$	clock HIGH time		100	-	ns
$t_{clk(L)}$	clock LOW time		150	-	ns
t_r	rise time	for SCL signal	-	100	ns
t_f	fall time	for SCL signal	-	100	ns
Pin CE					
$t_{su(CE_N)}$	CE_N set-up time		30	-	ns
$t_{h(CE_N)}$	CE_N hold time		30	-	ns
$t_{rec(CE_N)}$	CE_N recovery time		30	-	ns
Pin SDI/SDAIN					
t_{su}	set-up time	set-up time for SDI data	30	-	ns
t_h	hold time	hold time for SDI data	30	-	ns
Pin SDO					
$t_{d(R)SDO}$	SDO read delay time	$C_L = 100\text{ pF}$	-	150	ns
$t_{dis(SDO)}$	SDO disable time		[1]	50	ns
$t_t(SDI\text{-}SDO)$	transition time from SDI to SDO	to avoid bus conflict	0	-	ns

[1] No load value; bus will be held up by bus capacitance; use RC time constant with application values.

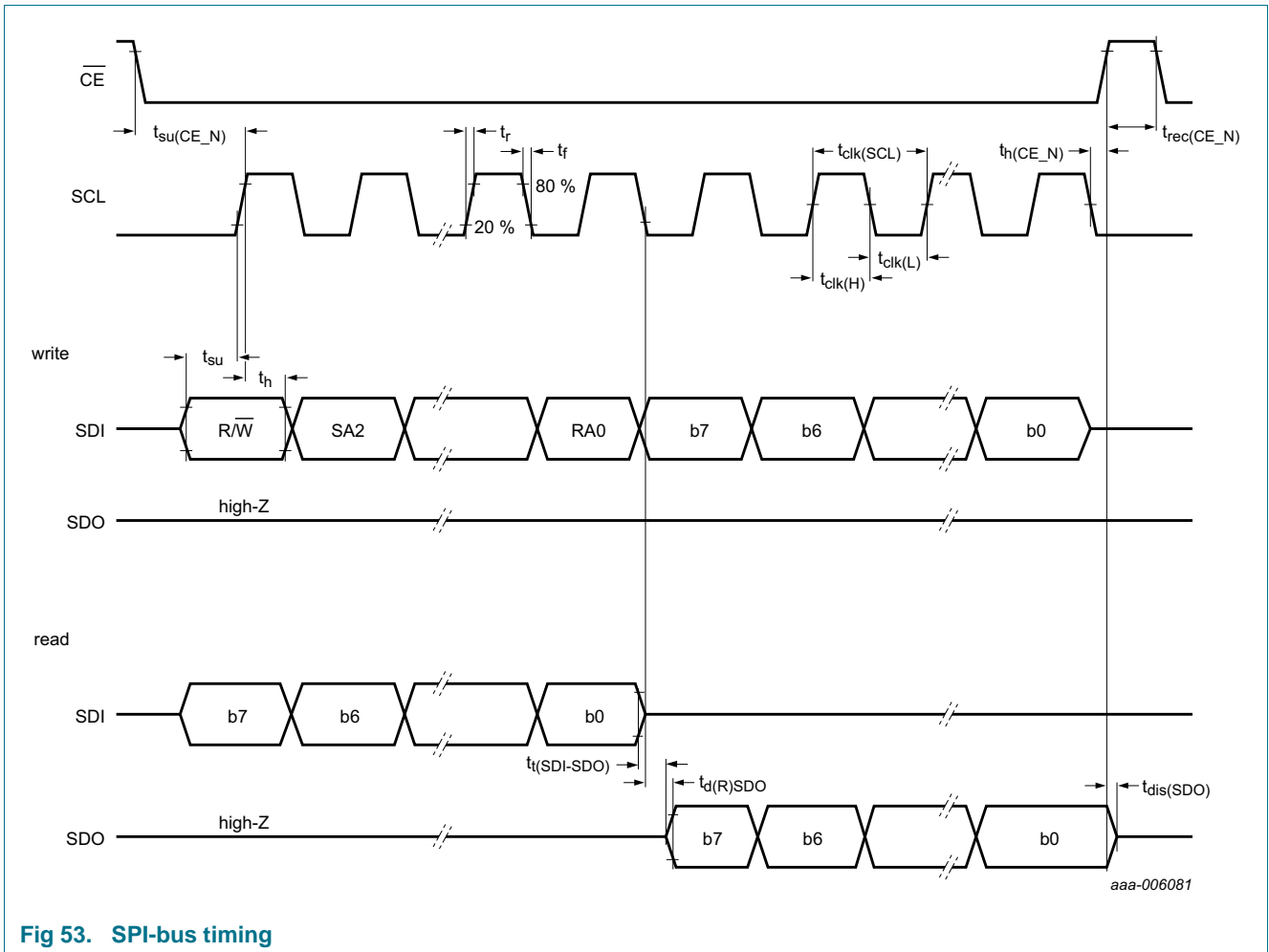

Fig 53. SPI-bus timing

15. Application information

15.1 ITO layout recommendations for ESD/EMC robustness in COG applications

The crucial factor for gaining an EMC and ESD robust application is the quality of the VSS1 line.

- To get an EMC/ESD robust ITO/glass layout, the $R_{ITO(VSS1)}$ has to be kept as low as possible.
- In the most common applications VSS1 is connected to the pins T1, T2, A0, A1, OSC, SA0, SA1 and IFS (in the case of using the SPI interface) by using a very wide ITO connection
- If possible, the ITO connection of VSS1 should be made wide, for example by fanning out the other connections
- When the display is enabled, the charge and discharge caused by display activity affects the VSS1 line. This causes a dynamic current in the VSS1 line which means that dynamic voltage peaks in the VSS1 line may interfere with the low voltage part of the PCA8530. Therefore a low $R_{ITO(VSS1)}$ is also important for an improved noise immunity of the PCA8530 especially at high V_{LCD} values ($V_{LCD} > 10$ V).
- A low $R_{ITO(VSS1)}$ also improves the communication stability with the microcontroller by reducing the effects of local ground (VSS1) bounce caused by high SDAACK currents.
- It should be considered that VSS1 is internally connected to the IC substrate, therefore noise on the VSS1 line causes noise inside the IC.

[Figure 54](#) and [Figure 55](#) are showing the recommended ITO connections for a COG layout according to the interface type use.

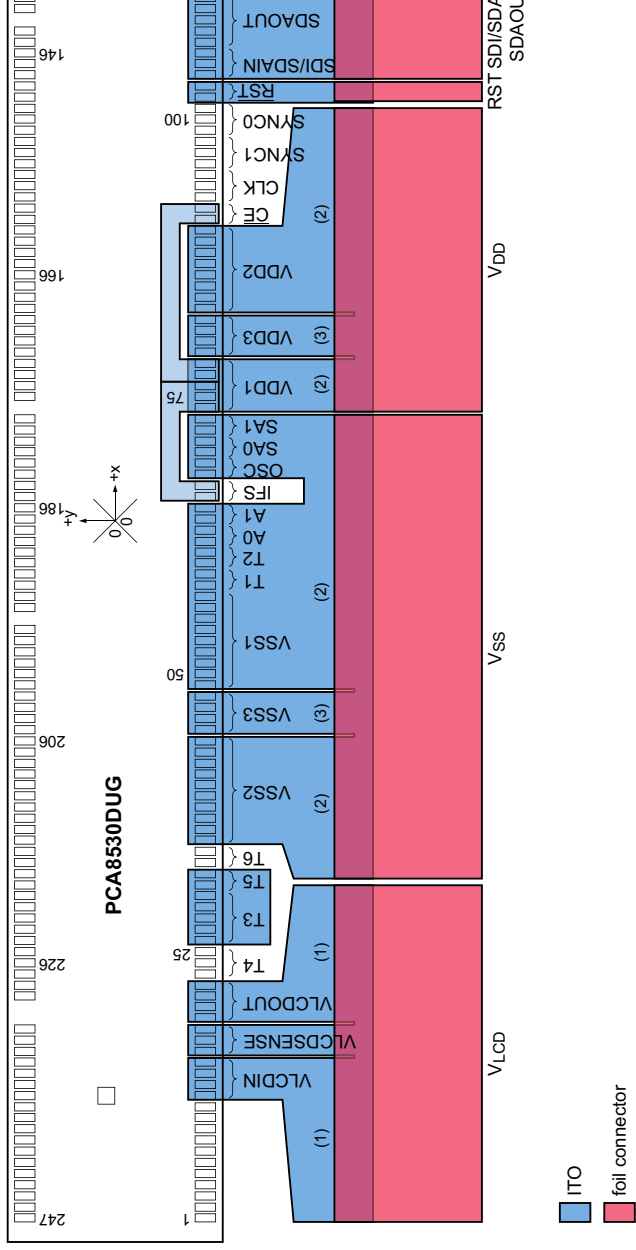

- (1) $R_{ITO} \leq 100 \Omega$.
- (2) $R_{ITO} \leq 50 \Omega$.
- (3) $R_{ITO} \leq 200 \Omega$.

Fig 54. Recommended ITO connections for the I²C interface

15.2 Cascaded operation

In large display configurations, up to four PCA8530 can be distinguished on the same bus by using the 2-bit hardware device addresses (A0 and A1).

Table 52. Addressing cascaded PCA8530

Pin A1	Pin A0	Device
0	0	0 (master)
0	1	1 (slave)
1	0	2 (slave)
1	1	3 (slave)

15.2.1 Wiring backplane and segment outputs

When the cascaded PCA8530 are synchronized, they can share the backplane signals from one of the devices in the cascade. Such an arrangement is cost-effective in large LCD applications since the backplane outputs of only one device need to be through-plated to the backplane electrodes of the display. The other PCA8530 of the cascade contribute additional segment outputs. The backplanes can either be connected together to enhance the drive capability or some can be left open-circuit (such as the ones from the slave in [Figure 56](#) and [Figure 57](#)) or just some of the master and some of the slave will be taken to facilitate the layout of the display.

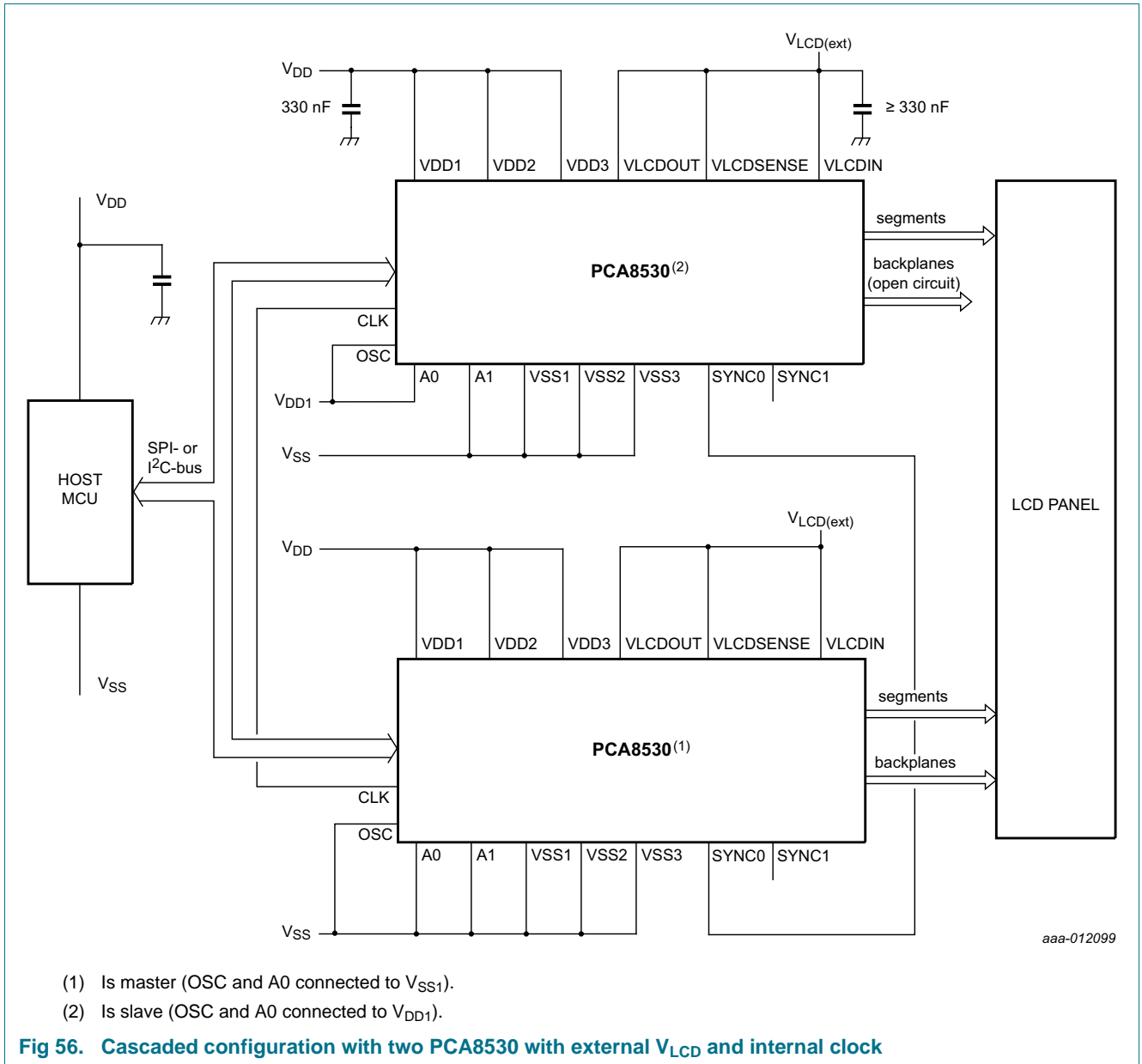

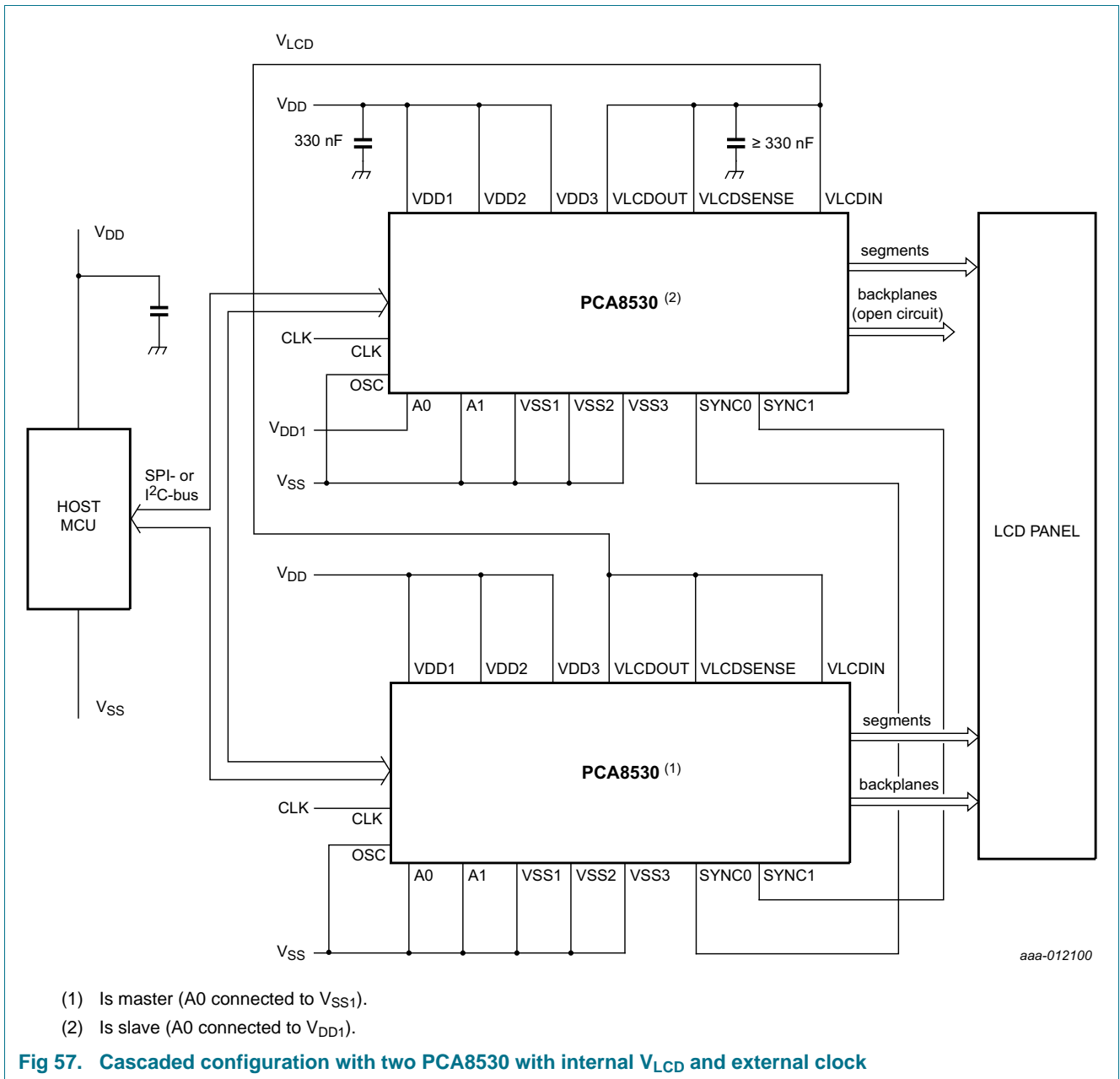

15.2.2 Device synchronization

The SYNC0 and SYNC1 lines are provided to maintain the correct synchronization between all cascaded PCA8530. (SYNC1 must not be connected when using an externally supplied V_{LCD}.) This synchronization is guaranteed after the Power-On Reset (POR). SYNC0 and SYNC1 are organized as input/output pins.

Both, the internally generated clock frequency or, alternatively, an externally supplied clock signal can be used in cascaded applications.

In cascaded applications that use the internal clock, the master PCA8530 with device address A[1:0] = 00 must have the OSC pin connected to V_{SS1} and the COE bit is set logic 1, so that this device uses its internal clock to generate a clock signal at the CLK pin.

The other PCA8530 devices are having the OSC pin connected to V_{DD1} , meaning that these devices are ready to receive an external clock signal which is provided by the master device with subaddress $A[1:0] = 00$.

If the master is providing the clock signal to the slave devices, care must be taken that the sending of display enable or disable will be received by both, the master and the slaves at the same time. When the display is disabled, the output from pin CLK is disabled too. The disconnection of the clock may result in a DC component for the display.

In cascaded applications that use an external clock, all devices have the OSC pin connected to V_{DD1} and thus an external CLK being provided for the system (all devices connected to the same external CLK).

15.2.3 Display data

The storage of display data is determined by the contents of the device address register (see [Section 8.2.3 on page 11](#)). Storage is allowed only when the content of the device address register matches with the hardware device address applied to the pins A0 and A1. If the content of the device address register and the hardware device address do not match, data storage is inhibited but the data pointer is incremented as if data storage had taken place. The hardware device address must not be changed while the device is being accessed on the interface.

15.2.4 Data read

Only when the content of the device address register (see [Section 8.2.3 on page 11](#)) matches with the hardware device address applied to the pins A0 and A1, the temperature or device status readout (see [Section 8.2.7 on page 13](#)) is activated. If the content of the device address register and the hardware device address do not match, the data output pin (SDA or SDO) of the device is in 3-state. With this, bus conflicts and incorrect reading is prevented.

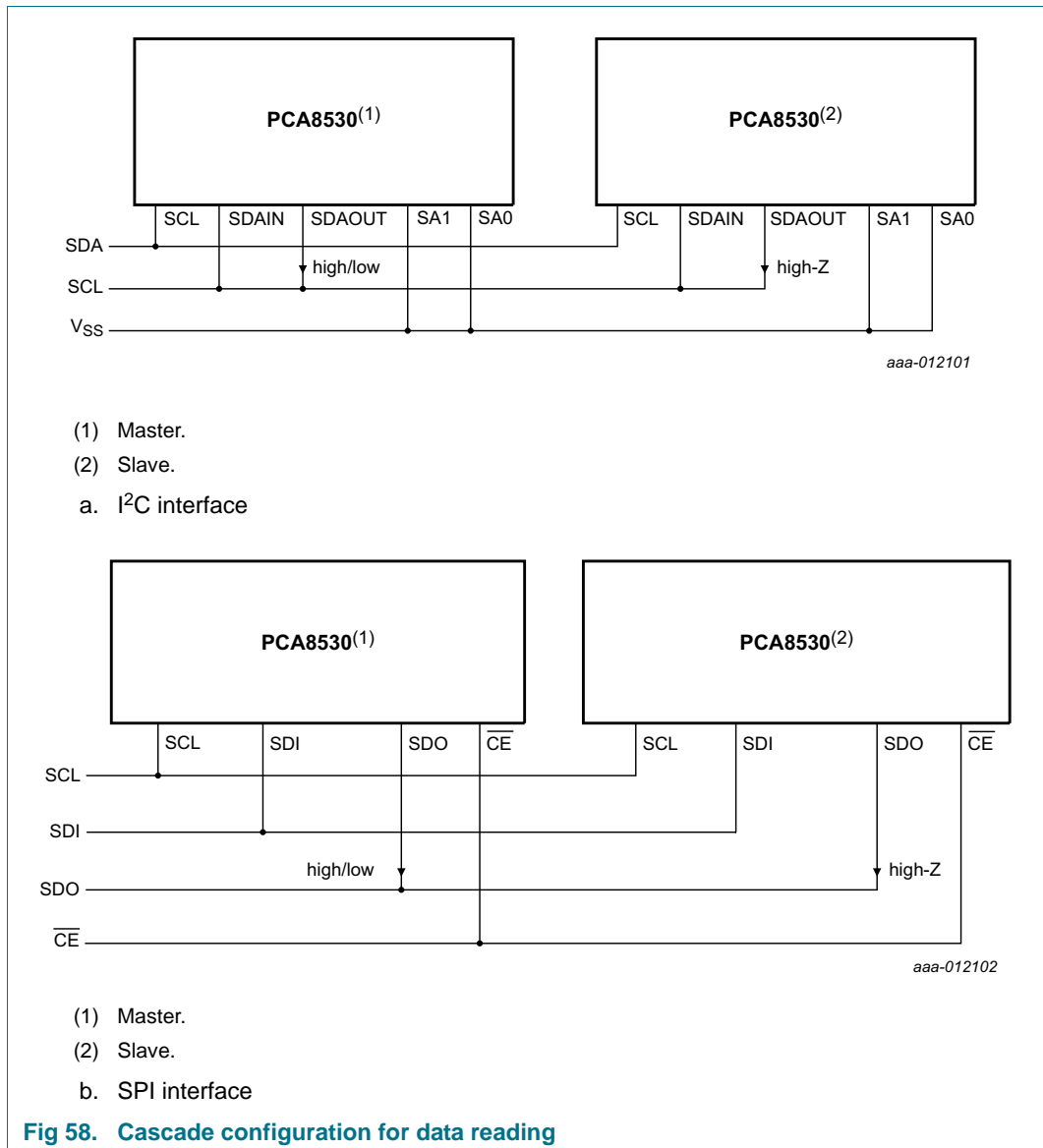

16. Test information

16.1 Quality information

This product has been qualified in accordance with the Automotive Electronics Council (AEC) standard Q100 - *Failure mechanism based stress test qualification for integrated circuits*, and is suitable for use in automotive applications.

17. Bare die outline

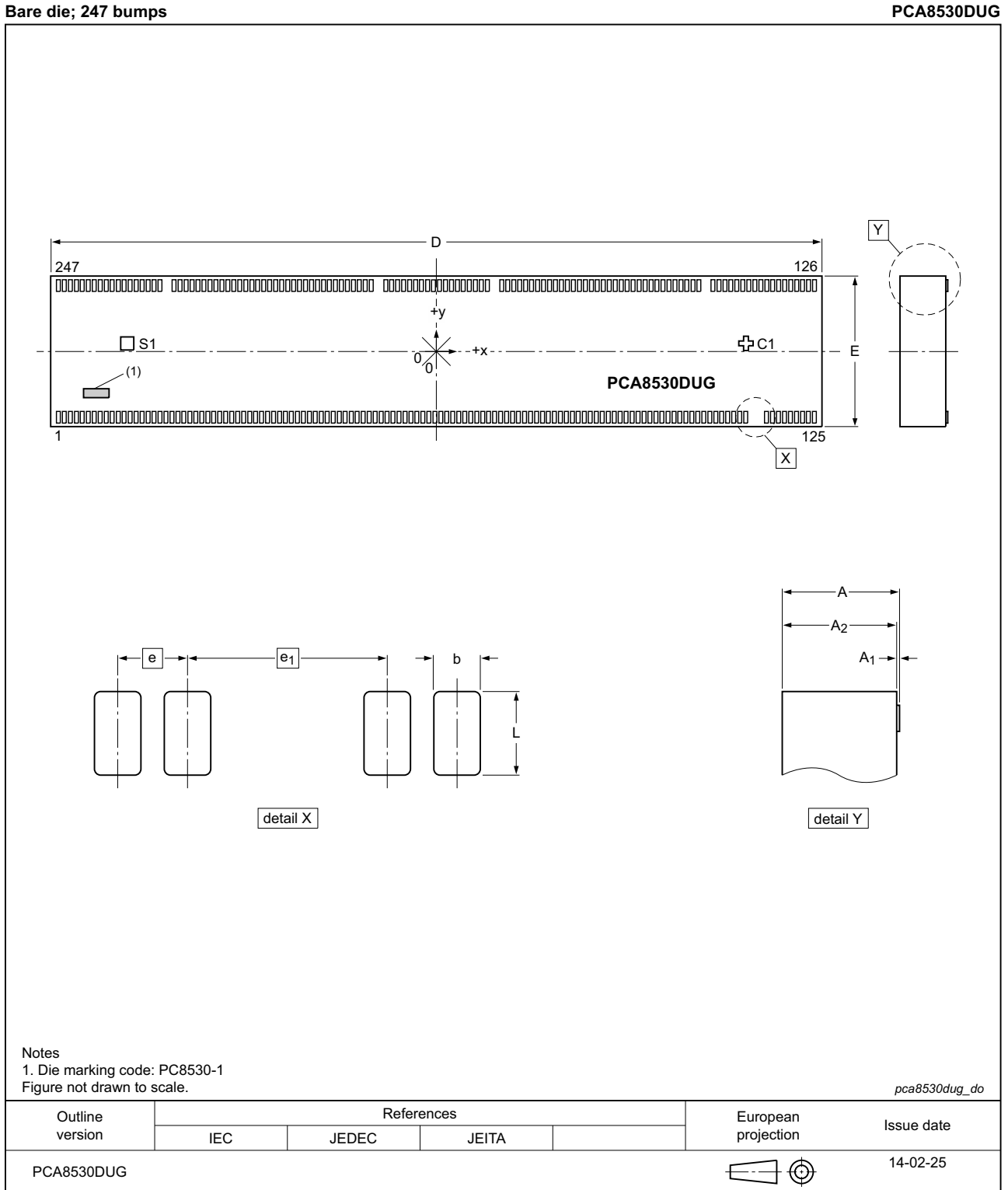

Fig 59. Bare die outline of PCA8530DUG

Table 53. Bump locations of PCA8530DUG

All x/y coordinates represent the position of the center of each bump with respect to the center (x/y = 0) of the chip; see [Figure 59](#).

Symbol	Pin	Coordinates		Pitch	Symbol	Pin	Coordinates		Pitch
		X (μm)	Y (μm)	X (μm)			X (μm)	Y (μm)	X (μm)
COM3	1	-2847.5	-495	-	S101	126	2846.7	495	-
	2	-2802.5	-495	45		127	2801.7	495	45
	3	-2757.5	-495	45	S100	128	2756.7	495	45
	4	-2712.5	-495	45	S99	129	2711.7	495	45
	5	-2667.5	-495	45	S98	130	2666.7	495	45
	6	-2622.5	-495	45	S97	131	2621.7	495	45
	7	-2577.5	-495	45	S96	132	2576.7	495	45
COM2	8	-2532.5	-495	45	S95	133	2531.7	495	45
	9	-2487.5	-495	45	S94	134	2486.7	495	45
	10	-2442.5	-495	45	S93	135	2441.7	495	45
	11	-2397.5	-495	45	S92	136	2396.7	495	45
VLCDIN	12	-2352.5	-495	45	S91	137	2351.7	495	45
	13	-2307.5	-495	45	S90	138	2306.7	495	45
	14	-2262.5	-495	45	S89	139	2261.7	495	45
	15	-2217.5	-495	45	S88	140	2216.7	495	45
VLCDSENSE	16	-2172.5	-495	45	S87	141	2171.7	495	45
	17	-2127.5	-495	45	S86	142	2126.7	495	45
	18	-2082.5	-495	45	S85	143	2081.7	495	45
VLCDOUT	19	-2037.5	-495	45	S84	144	1975.7	495	106
	20	-1992.5	-495	45	S83	145	1930.7	495	45
	21	-1947.5	-495	45	S82	146	1885.7	495	45
	22	-1902.5	-495	45	S81	147	1840.7	495	45
T4	23	-1857.5	-495	45	S80	148	1795.7	495	45
	24	-1812.5	-495	45	S79	149	1750.7	495	45
	25	-1767.5	-495	45	S78	150	1705.7	495	45
T3	26	-1722.5	-495	45	S77	151	1660.7	495	45
	27	-1677.5	-495	45	S76	152	1615.7	495	45
	28	-1632.5	-495	45	S75	153	1570.7	495	45
	29	-1587.5	-495	45	S74	154	1525.7	495	45
	30	-1542.5	-495	45	S73	155	1480.7	495	45
T5	31	-1497.5	-495	45	S72	156	1435.7	495	45
	32	-1452.5	-495	45	S71	157	1390.7	495	45
T6	33	-1407.5	-495	45	S70	158	1345.7	495	45
	34	-1362.5	-495	45	S69	159	1300.7	495	45

Table 53. Bump locations of PCA8530DUG ...continued

All x/y coordinates represent the position of the center of each bump with respect to the center (x/y = 0) of the chip; see [Figure 59](#).

Symbol	Pin	Coordinates		Pitch	Symbol	Pin	Coordinates		Pitch	
		X (μm)	Y (μm)				X (μm)	Y (μm)		X (μm)
VSS2	35	-1317.5	-495	45	S68	160	1255.7	495	45	
	36	-1272.5	-495	45	S67	161	1210.7	495	45	
	37	-1227.5	-495	45	S66	162	1165.7	495	45	
	38	-1182.5	-495	45	S65	163	1120.7	495	45	
	39	-1137.5	-495	45	S64	164	1075.7	495	45	
	40	-1092.5	-495	45	S63	165	1030.7	495	45	
	41	-1047.5	-495	45	S62	166	985.7	495	45	
	42	-1002.5	-495	45	S61	167	940.7	495	45	
	43	-957.5	-495	45	S60	168	895.7	495	45	
	44	-912.5	-495	45	S59	169	850.7	495	45	
VSS3	45	-867.5	-495	45	S58	170	805.7	495	45	
	46	-822.5	-495	45	S57	171	760.7	495	45	
	47	-777.5	-495	45	S56	172	715.7	495	45	
	48	-732.5	-495	45	S55	173	670.7	495	45	
VSS1	49	-687.5	-495	45	S54	174	625.7	495	45	
	50	-642.5	-495	45	S53	175	580.7	495	45	
	51	-597.5	-495	45	S52	176	535.7	495	45	
	52	-552.5	-495	45	S51	177	490.7	495	45	
	53	-507.5	-495	45	COM0	178	382.1	495	108.6	
	54	-462.5	-495	45		179	337.1	495	45	
	55	-417.5	-495	45		180	292.1	495	45	
	56	-372.5	-495	45		181	247.1	495	45	
	T1	57	-327.5	-495	45	COM1	182	202.1	495	45
58		-282.5	-495	45	183		157.1	495	45	
59		-237.5	-495	45	184		112.1	495	45	
T2	60	-192.5	-495	45	COM2	185	67.1	495	45	
	61	-147.5	-495	45		186	22.1	495	45	
A0	62	-102.5	-495	45		187	-22.9	495	45	
	63	-57.5	-495	45		188	-67.9	495	45	
A1	64	-12.5	-495	45		189	-112.9	495	45	
	65	32.5	-495	45		COM3	190	-157.9	495	45
IFS	66	77.5	-495	45			191	-202.9	495	45
	67	122.5	-495	45			192	-247.9	495	45
OSC	68	167.5	-495	45			193	-292.9	495	45
	69	212.5	-495	45	194		-337.9	495	45	
SA0	70	257.5	-495	45	195		-382.9	495	45	
	71	302.5	-495	45	S50		196	-491.5	495	108.6

Table 53. Bump locations of PCA8530DUG ...continued

All x/y coordinates represent the position of the center of each bump with respect to the center (x/y = 0) of the chip; see [Figure 59](#).

Symbol	Pin	Coordinates		Pitch	Symbol	Pin	Coordinates		Pitch
		X (μm)	Y (μm)				X (μm)	Y (μm)	
SA1	72	347.5	-495	45	S49	197	-536.5	495	45
	73	392.5	-495	45	S48	198	-581.5	495	45
VDD1	74	437.5	-495	45	S47	199	-626.5	495	45
	75	482.5	-495	45	S46	200	-671.5	495	45
	76	527.5	-495	45	S45	201	-716.5	495	45
	77	572.5	-495	45	S44	202	-761.5	495	45
	78	617.5	-495	45	S43	203	-806.5	495	45
VDD3	79	662.5	-495	45	S42	204	-851.5	495	45
	80	707.5	-495	45	S41	205	-896.5	495	45
	81	752.5	-495	45	S40	206	-941.5	495	45
	82	797.5	-495	45	S39	207	-986.5	495	45
VDD2	83	842.5	-495	45	S38	208	-1031.5	495	45
	84	887.5	-495	45	S37	209	-1076.5	495	45
	85	932.5	-495	45	S36	210	-1121.5	495	45
	86	977.5	-495	45	S35	211	-1166.5	495	45
	87	1022.5	-495	45	S34	212	-1211.5	495	45
	88	1067.5	-495	45	S33	213	-1256.5	495	45
	89	1112.5	-495	45	S32	214	-1301.5	495	45
	90	1157.5	-495	45	S31	215	-1346.5	495	45
CE	91	1202.5	-495	45	S30	216	-1391.5	495	45
	92	1247.5	-495	45	S29	217	-1436.5	495	45
CLK	93	1292.5	-495	45	S28	218	-1481.5	495	45
	94	1337.5	-495	45	S27	219	-1526.5	495	45
	95	1382.5	-495	45	S26	220	-1571.5	495	45
SYNC1	96	1427.5	-495	45	S25	221	-1616.5	495	45
	97	1472.5	-495	45	S24	222	-1661.5	495	45
	98	1517.5	-495	45	S23	223	-1706.5	495	45
SYNC0	99	1562.5	-495	45	S22	224	-1751.5	495	45
	100	1607.5	-495	45	S21	225	-1796.5	495	45
	101	1652.5	-495	45	S20	226	-1841.5	495	45
RST	102	1697.5	-495	45	S19	227	-1886.5	495	45
	103	1742.5	-495	45	S18	228	-1931.5	495	45
SDI/SDAIN	104	1787.5	-495	45	S17	229	-1976.5	495	45
	105	1832.5	-495	45	S16	230	-2022.5	495	106
	106	1877.5	-495	45	S15	231	-2127.5	495	45

Table 53. Bump locations of PCA8530DUG ...continued

All x/y coordinates represent the position of the center of each bump with respect to the center (x/y = 0) of the chip; see [Figure 59](#).

Symbol	Pin	Coordinates		Pitch	Symbol	Pin	Coordinates		Pitch
		X (μm)	Y (μm)	X (μm)			X (μm)	Y (μm)	X (μm)
SDAOUT	107	1922.5	-495	45	S14	232	-2172.5	495	45
	108	1967.5	-495	45	S13	233	-2217.5	495	45
	109	2012.5	-495	45	S12	234	-2262.5	495	45
	110	2057.5	-495	45	S11	235	-2307.5	495	45
	111	2102.5	-495	45	S10	236	-2352.5	495	45
SDO	112	2147.5	-495	45	S9	237	-2397.5	495	45
	113	2192.5	-495	45	S8	238	-2442.5	495	45
SCL	114	2237.5	-495	45	S7	239	-2487.5	495	45
	115	2282.5	-495	45	S6	240	-2532.5	495	45
	116	2327.5	-495	45	S5	241	-2577.5	495	45
COM1	117	2485.2	-495	157.7	S4	242	-2622.5	495	45
	118	2530.2	-495	45	S3	243	-2667.5	495	45
	119	2575.2	-495	45	S2	244	-2712.5	495	45
	120	2620.2	-495	45	S1	245	-2757.5	495	45
COM0	121	2665.2	-495	45	S0	246	-2802.5	495	45
	122	2710.2	-495	45		247	-2847.5	495	45
	123	2755.2	-495	45	-	-	-	-	-
	124	2800.2	-495	45	-	-	-	-	-
	125	2845.2	-495	45	-	-	-	-	-

Table 54. Dimensions of PCA8530DUG

Original dimensions are in mm.

Unit (mm)	A	A ₁	A ₂	b	D	E	e	e ₁	L
max	-	0.018	-	-	-	-	-	-	-
nom	0.40	0.015	0.38	0.03	5.88	1.20	0.045	0.158	0.09
min	-	0.012	-	-	-	-	-	-	-

The alignment marks are shown in [Table 55](#).

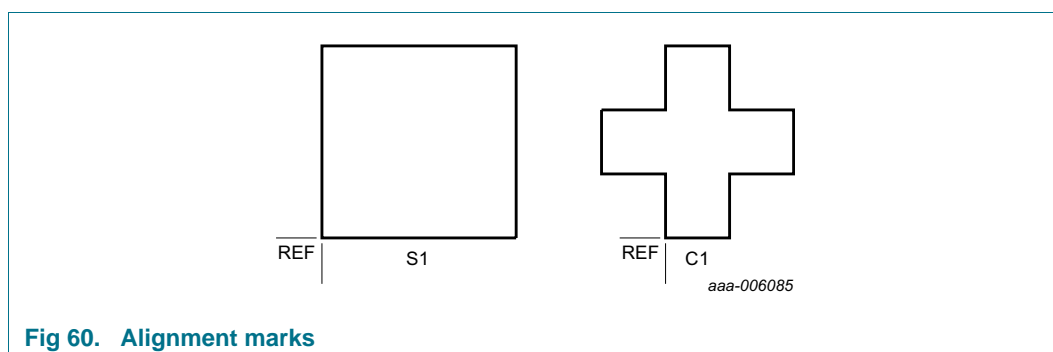

Fig 60. Alignment marks

Table 55. Alignment marking

All x/y coordinates represent the position of the REF point (see [Figure 60](#)) with respect to the center ($x/y = 0$) of the chip; see [Figure 59](#).

Symbol	Size (μm)	X (μm)	Y (μm)
S1	90 × 90	-2375	15
C1	90 × 90	2312	15

Table 56. Gold bump hardness

Type number	Min	Max	Unit ^[1]
PCA8530DUG/DA	60	120	HV

[1] Pressure of diamond head: 10 g to 50 g.

18. Handling information

All input and output pins are protected against ElectroStatic Discharge (ESD) under normal handling. When handling Metal-Oxide Semiconductor (MOS) devices ensure that all normal precautions are taken as described in *JESD625-A*, *IEC 61340-5* or equivalent standards.

19. Packing information

19.1 Tray information

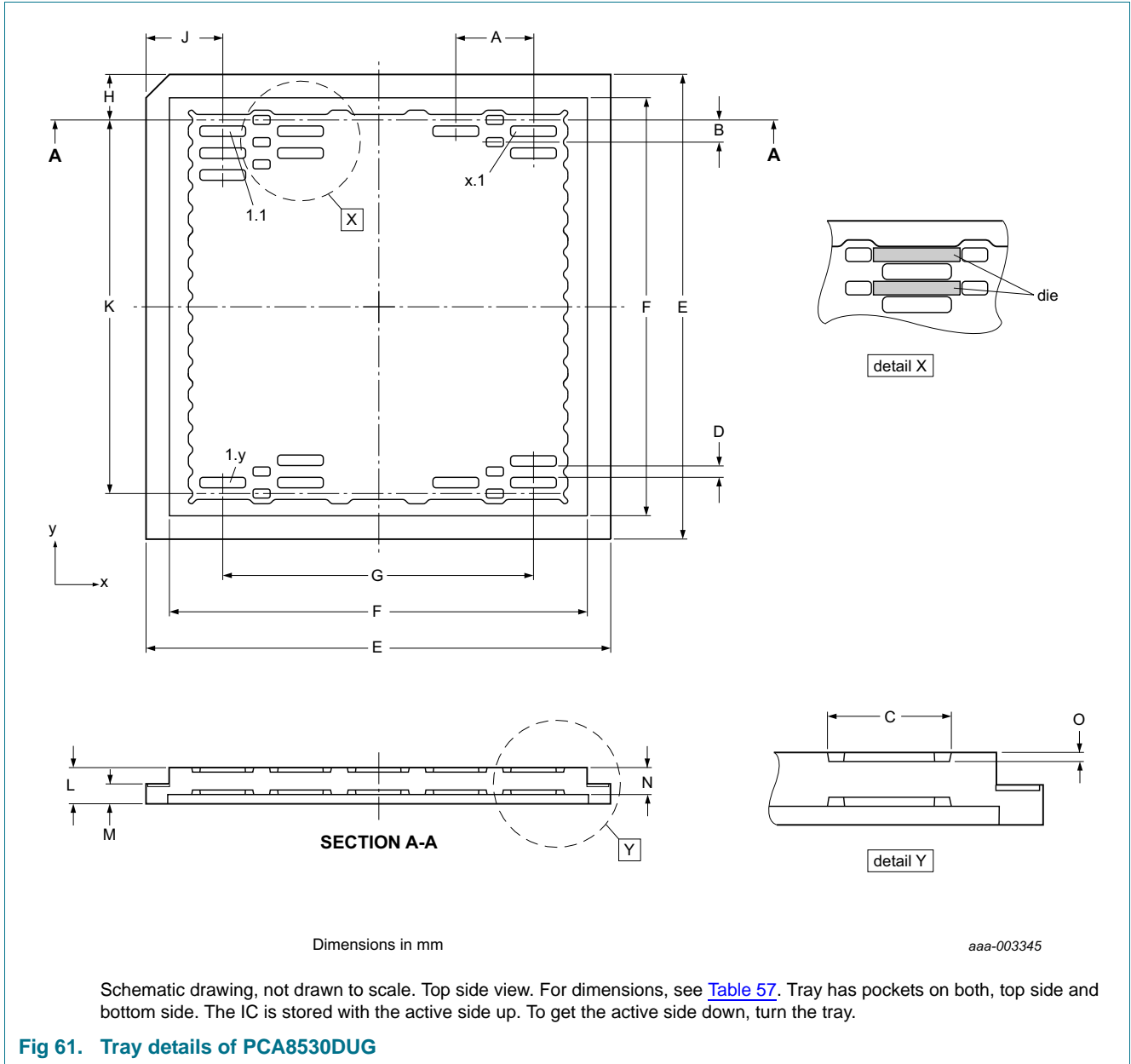
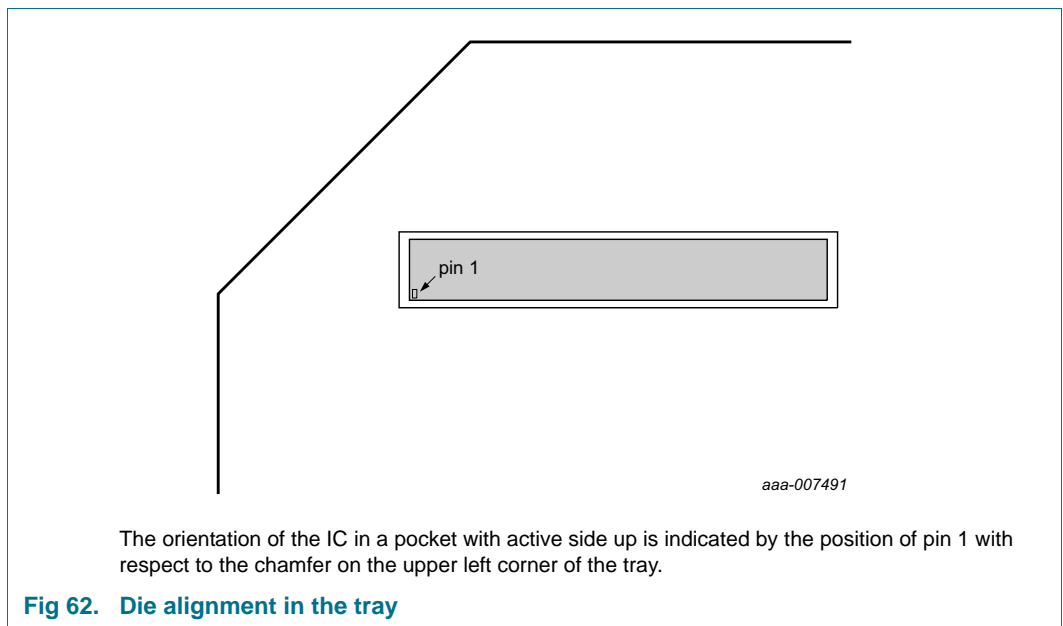

Fig 61. Tray details of PCA8530DUG

Table 57. Description of tray details

Tray details are shown in [Figure 61](#).

Tray details														
Dimensions														
A	B	C	D	E	F	G	H	J	K	L	M	N	O	Unit
8	2.5	5.978	1.298	76	68	56	6.75	10	62.5	4.2	2.6	3.2	0.6	mm
Number of pockets														
x direction							y direction							
8							26							



20. Appendix

20.1 LCD segment driver selection

Table 58. Selection of LCD segment drivers

Type name	Number of elements at MUX							V _{DD} (V)	V _{LCD} (V)	f _{fr} (Hz)	V _{LCD} (V) charge pump	V _{LCD} (V) temperature compensat.	T _{amb} (°C)
	1:1	1:2	1:3	1:4	1:6	1:8	1:9						
PCA8553DTT	40	80	120	160	-	-	-	1.8 to 5.5	1.8 to 5.5	32 to 256 ^[1]	N	N	-40 to 105
PCA8546ATT	-	-	-	176	-	-	-	1.8 to 5.5	2.5 to 9	60 to 300 ^[1]	N	N	-40 to 95
PCA8546BTT	-	-	-	176	-	-	-	1.8 to 5.5	2.5 to 9	60 to 300 ^[1]	N	N	-40 to 95
PCA8547AHT	44	88	-	176	-	-	-	1.8 to 5.5	2.5 to 9	60 to 300 ^[1]	Y	Y	-40 to 95
PCA8547BHT	44	88	-	176	-	-	-	1.8 to 5.5	2.5 to 9	60 to 300 ^[1]	Y	Y	-40 to 95
PCF85134HL	60	120	180	240	-	-	-	1.8 to 5.5	2.5 to 6.5	82	N	N	-40 to 85
PCA85134H	60	120	180	240	-	-	-	1.8 to 5.5	2.5 to 8	82	N	N	-40 to 95
PCA8543AHL	60	120	-	240	-	-	-	2.5 to 5.5	2.5 to 9	60 to 300 ^[1]	Y	Y	-40 to 105
PCF8545ATT	-	-	-	176	252	320	-	1.8 to 5.5	2.5 to 5.5	60 to 300 ^[1]	N	N	-40 to 85
PCF8545BTT	-	-	-	176	252	320	-	1.8 to 5.5	2.5 to 5.5	60 to 300 ^[1]	N	N	-40 to 85
PCF8536AT	-	-	-	176	252	320	-	1.8 to 5.5	2.5 to 9	60 to 300 ^[1]	N	N	-40 to 85
PCF8536BT	-	-	-	176	252	320	-	1.8 to 5.5	2.5 to 9	60 to 300 ^[1]	N	N	-40 to 85
PCA8536AT	-	-	-	176	252	320	-	1.8 to 5.5	2.5 to 9	60 to 300 ^[1]	N	N	-40 to 95
PCA8536BT	-	-	-	176	252	320	-	1.8 to 5.5	2.5 to 9	60 to 300 ^[1]	N	N	-40 to 95
PCF8537AH	44	88	-	176	276	352	-	1.8 to 5.5	2.5 to 9	60 to 300 ^[1]	Y	Y	-40 to 85
PCF8537BH	44	88	-	176	276	352	-	1.8 to 5.5	2.5 to 9	60 to 300 ^[1]	Y	Y	-40 to 85
PCA8537AH	44	88	-	176	276	352	-	1.8 to 5.5	2.5 to 9	60 to 300 ^[1]	Y	Y	-40 to 95
PCA8537BH	44	88	-	176	276	352	-	1.8 to 5.5	2.5 to 9	60 to 300 ^[1]	Y	Y	-40 to 95
PCA9620H	60	120	-	240	320	480	-	2.5 to 5.5	2.5 to 9	60 to 300 ^[1]	Y	Y	-40 to 105
PCA9620U	60	120	-	240	320	480	-	2.5 to 5.5	2.5 to 9	60 to 300 ^[1]	Y	Y	-40 to 105
PCF8576DU	40	80	120	160	-	-	-	1.8 to 5.5	2.5 to 6.5	77	N	N	-40 to 85
PCF8576EUG	40	80	120	160	-	-	-	1.8 to 5.5	2.5 to 6.5	77	N	N	-40 to 85
PCA8576FUG	40	80	120	160	-	-	-	1.8 to 5.5	2.5 to 8	200	N	N	-40 to 105
PCF85133U	80	160	240	320	-	-	-	1.8 to 5.5	2.5 to 6.5	82, 110 ^[2]	N	N	-40 to 85
PCA85133U	80	160	240	320	-	-	-	1.8 to 5.5	2.5 to 8	82, 110 ^[2]	N	N	-40 to 95

Table 58. Selection of LCD segment drivers ... continued

Type name	Number of elements at MUX						V _{DD} (V)	V _{LCD} (V)	f _{fr} (Hz)	V _{LCD} (V) charge pump	V _{LCD} (V) temperature compensat.	T _{amb} (°C)
	1:1	1:2	1:3	1:4	1:6	1:8						
PCA85233UG	80	160	240	320	-	-	-	1.8 to 5.5	2.5 to 8	150, 220 ^[2]	N	-40 to 105
PCF85132U	160	320	480	640	-	-	-	1.8 to 5.5	1.8 to 8	60 to 90 ^[1]	N	-40 to 85
PCA8530DUG	102	204	-	408	-	-	-	2.5 to 5.5	4 to 12	45 to 300 ^[1]	Y	-40 to 105
PCA85132U	160	320	480	640	-	-	-	1.8 to 5.5	1.8 to 8	60 to 90 ^[1]	N	-40 to 95
PCA85232U	160	320	480	640	-	-	-	1.8 to 5.5	1.8 to 8	117 to 176 ^[1]	N	-40 to 95
PCF8538UG	102	204	-	408	612	816	918	2.5 to 5.5	4 to 12	45 to 300 ^[1]	Y	-40 to 85
PCA8538UG	102	204	-	408	612	816	918	2.5 to 5.5	4 to 12	45 to 300 ^[1]	Y	-40 to 105

[1] Software programmable.

[2] Hardware selectable.

21. Abbreviations

Table 59. Abbreviations

Acronym	Description
AEC	Automotive Electronics Council
COG	Chip-On-Glass
DC	Direct Current
EPROM	Erasable Programmable Read-Only Memory
ESD	ElectroStatic Discharge
HBM	Human Body Model
I ² C	Inter-Integrated Circuit bus
IC	Integrated Circuit
ITO	Indium Tin Oxide
LCD	Liquid Crystal Display
LSB	Least Significant Bit
MCU	Microcontroller Unit
MM	Machine Model
MSB	Most Significant Bit
MSL	Moisture Sensitivity Level
MUX	Multiplexer
OTP	One Time Programmable
POR	Power-On Reset
RC	Resistance-Capacitance
RAM	Random Access Memory
RMS	Root Mean Square
SCL	Serial CLock line
SDA	Serial DAta line
SMD	Surface Mount Device
SPI	Serial Peripheral Interface
VA	Vertical Alignment

22. References

- [1] **AN10170** — Design guidelines for COG modules with NXP monochrome LCD drivers
- [2] **AN10439** — Wafer Level Chip Size Package
- [3] **AN10853** — ESD and EMC sensitivity of IC
- [4] **AN10706** — Handling bare die
- [5] **AN11267** — EMC and system level ESD design guidelines for LCD drivers
- [6] **IEC 60134** — Rating systems for electronic tubes and valves and analogous semiconductor devices
- [7] **IEC 61340-5** — Protection of electronic devices from electrostatic phenomena
- [8] **JESD22-A114** — Electrostatic Discharge (ESD) Sensitivity Testing Human Body Model (HBM)
- [9] **JESD78** — IC Latch-Up Test
- [10] **JESD625-A** — Requirements for Handling Electrostatic-Discharge-Sensitive (ESDS) Devices
- [11] **R_10015** — Chip-On-Glass (COG) – a cost-effective and reliable technology for LCD displays, White Paper
- [12] **SNV-FA-01-02** — Marking Formats Integrated Circuits
- [13] **UM10204** — I²C-bus specification and user manual
- [14] **UM10569** — Store and transport requirements

23. Revision history

Table 60. Revision history

Document ID	Release date	Data sheet status	Change notice	Supersedes
PCA8530 v.2	20140925	Product data sheet	-	PCA8530 v.1
Modifications:	• Adjusted Figure 13 , Figure 56 , Section 8.9 and Section 8.10			
PCA8530 v.1	20140815	Product data sheet	-	-

24. Legal information

24.1 Data sheet status

Document status ^{[1][2]}	Product status ^[3]	Definition
Objective [short] data sheet	Development	This document contains data from the objective specification for product development.
Preliminary [short] data sheet	Qualification	This document contains data from the preliminary specification.
Product [short] data sheet	Production	This document contains the product specification.

[1] Please consult the most recently issued document before initiating or completing a design.

[2] The term 'short data sheet' is explained in section "Definitions".

[3] The product status of device(s) described in this document may have changed since this document was published and may differ in case of multiple devices. The latest product status information is available on the Internet at URL <http://www.nxp.com>.

24.2 Definitions

Draft — The document is a draft version only. The content is still under internal review and subject to formal approval, which may result in modifications or additions. NXP Semiconductors does not give any representations or warranties as to the accuracy or completeness of information included herein and shall have no liability for the consequences of use of such information.

Short data sheet — A short data sheet is an extract from a full data sheet with the same product type number(s) and title. A short data sheet is intended for quick reference only and should not be relied upon to contain detailed and full information. For detailed and full information see the relevant full data sheet, which is available on request via the local NXP Semiconductors sales office. In case of any inconsistency or conflict with the short data sheet, the full data sheet shall prevail.

Product specification — The information and data provided in a Product data sheet shall define the specification of the product as agreed between NXP Semiconductors and its customer, unless NXP Semiconductors and customer have explicitly agreed otherwise in writing. In no event however, shall an agreement be valid in which the NXP Semiconductors product is deemed to offer functions and qualities beyond those described in the Product data sheet.

24.3 Disclaimers

Limited warranty and liability — Information in this document is believed to be accurate and reliable. However, NXP Semiconductors does not give any representations or warranties, expressed or implied, as to the accuracy or completeness of such information and shall have no liability for the consequences of use of such information. NXP Semiconductors takes no responsibility for the content in this document if provided by an information source outside of NXP Semiconductors.

In no event shall NXP Semiconductors be liable for any indirect, incidental, punitive, special or consequential damages (including - without limitation - lost profits, lost savings, business interruption, costs related to the removal or replacement of any products or rework charges) whether or not such damages are based on tort (including negligence), warranty, breach of contract or any other legal theory.

Notwithstanding any damages that customer might incur for any reason whatsoever, NXP Semiconductors' aggregate and cumulative liability towards customer for the products described herein shall be limited in accordance with the *Terms and conditions of commercial sale* of NXP Semiconductors.

Right to make changes — NXP Semiconductors reserves the right to make changes to information published in this document, including without limitation specifications and product descriptions, at any time and without notice. This document supersedes and replaces all information supplied prior to the publication hereof.

Suitability for use in automotive applications — This NXP Semiconductors product has been qualified for use in automotive applications. Unless otherwise agreed in writing, the product is not designed, authorized or warranted to be suitable for use in life support, life-critical or safety-critical systems or equipment, nor in applications where failure or malfunction of an NXP Semiconductors product can reasonably be expected to result in personal injury, death or severe property or environmental damage. NXP Semiconductors and its suppliers accept no liability for inclusion and/or use of NXP Semiconductors products in such equipment or applications and therefore such inclusion and/or use is at the customer's own risk.

Applications — Applications that are described herein for any of these products are for illustrative purposes only. NXP Semiconductors makes no representation or warranty that such applications will be suitable for the specified use without further testing or modification.

Customers are responsible for the design and operation of their applications and products using NXP Semiconductors products, and NXP Semiconductors accepts no liability for any assistance with applications or customer product design. It is customer's sole responsibility to determine whether the NXP Semiconductors product is suitable and fit for the customer's applications and products planned, as well as for the planned application and use of customer's third party customer(s). Customers should provide appropriate design and operating safeguards to minimize the risks associated with their applications and products.

NXP Semiconductors does not accept any liability related to any default, damage, costs or problem which is based on any weakness or default in the customer's applications or products, or the application or use by customer's third party customer(s). Customer is responsible for doing all necessary testing for the customer's applications and products using NXP Semiconductors products in order to avoid a default of the applications and the products or of the application or use by customer's third party customer(s). NXP does not accept any liability in this respect.

Limiting values — Stress above one or more limiting values (as defined in the Absolute Maximum Ratings System of IEC 60134) will cause permanent damage to the device. Limiting values are stress ratings only and (proper) operation of the device at these or any other conditions above those given in the Recommended operating conditions section (if present) or the Characteristics sections of this document is not warranted. Constant or repeated exposure to limiting values will permanently and irreversibly affect the quality and reliability of the device.

Terms and conditions of commercial sale — NXP Semiconductors products are sold subject to the general terms and conditions of commercial sale, as published at <http://www.nxp.com/profile/terms>, unless otherwise agreed in a valid written individual agreement. In case an individual agreement is concluded only the terms and conditions of the respective agreement shall apply. NXP Semiconductors hereby expressly objects to applying the customer's general terms and conditions with regard to the purchase of NXP Semiconductors products by customer.

No offer to sell or license — Nothing in this document may be interpreted or construed as an offer to sell products that is open for acceptance or the grant, conveyance or implication of any license under any copyrights, patents or other industrial or intellectual property rights.

Export control — This document as well as the item(s) described herein may be subject to export control regulations. Export might require a prior authorization from competent authorities.

Translations — A non-English (translated) version of a document is for reference only. The English version shall prevail in case of any discrepancy between the translated and English versions.

Bare die — All die are tested on compliance with their related technical specifications as stated in this data sheet up to the point of wafer sawing and are handled in accordance with the NXP Semiconductors storage and transportation conditions. If there are data sheet limits not guaranteed, these will be separately indicated in the data sheet. There are no post-packing tests performed on individual die or wafers.

NXP Semiconductors has no control of third party procedures in the sawing, handling, packing or assembly of the die. Accordingly, NXP Semiconductors assumes no liability for device functionality or performance of the die or systems after third party sawing, handling, packing or assembly of the die. It is the responsibility of the customer to test and qualify their application in which the die is used.

All die sales are conditioned upon and subject to the customer entering into a written die sale agreement with NXP Semiconductors through its legal department.

24.4 Trademarks

Notice: All referenced brands, product names, service names and trademarks are the property of their respective owners.

I²C-bus — logo is a trademark of NXP Semiconductors N.V.

25. Contact information

For more information, please visit: <http://www.nxp.com>

For sales office addresses, please send an email to: salesaddresses@nxp.com

26. Tables

Table 1.	Ordering information	3	Table 36.	Mapping of output pins and corresponding output signals with respect to the multiplex driving mode	50
Table 2.	Ordering options	3	Table 37.	Layout topology of output pins and corresponding output signals with respect to the multiplex driving mode	50
Table 3.	Marking codes	3	Table 38.	Bit scheme used to illustrate the RAM filling patterns	52
Table 4.	Pin description	6	Table 39.	RAM filling in static drive mode	52
Table 5.	Commands of PCA8530	8	Table 40.	RAM filling in 1:2 multiplex drive mode	52
Table 6.	Initialize command bit description	10	Table 41.	RAM filling in 1:4 multiplex drive mode	53
Table 7.	OTP-refresh - OTP-refresh command bit description	10	Table 42.	Control byte description	56
Table 8.	Device-address - device address command bit description	11	Table 43.	I ² C slave address byte	59
Table 9.	SYNC1_pin - SYNC1 pin configuration command bit description	11	Table 44.	R/W-bit description	59
Table 10.	Clock-out-ctrl - CLK pin input/output switch command bit description	12	Table 45.	Serial interface	61
Table 11.	Read-select - status read select command bit description	12	Table 46.	Subaddress byte definition	61
Table 12.	Status-readout - status and temperature read command bit description	13	Table 47.	Limiting values	65
Table 13.	Clear-reset-flag - Clear-reset-flag command bit description	14	Table 48.	Static characteristics	66
Table 14.	Charge-pump-ctrl - charge pump control command bit description	15	Table 49.	General dynamic characteristics	73
Table 15.	Set-V _{LCD} - Set-V _{LCD} command bit description	15	Table 50.	I ² C-bus timing characteristic	74
Table 16.	Set-bias-mode - set bias mode command bit description	16	Table 51.	SPI-bus timing characteristics	75
Table 17.	Temperature-ctrl - temperature measurement control command bit description	17	Table 52.	Addressing cascaded PCA8530	80
Table 18.	TC-set - V _{LCD} temperature compensation set command bit description	18	Table 53.	Bump locations of PCA8530DUG	86
Table 19.	TC-slope - V _{LCD} temperature compensation slope command bit description	19	Table 54.	Dimensions of PCA8530DUG	89
Table 20.	Set-MUX-mode - set multiplex drive mode command bit description	20	Table 55.	Alignment marking	90
Table 21.	Inversion-mode - inversion mode command bit description	20	Table 56.	Gold bump hardness	90
Table 22.	Display-ctrl - display on and off switch command bit description	21	Table 57.	Description of tray details	92
Table 23.	Frame-frequency - frame frequency select command bit description	22	Table 58.	Selection of LCD segment drivers	93
Table 24.	Clock and frame frequency values	23	Table 59.	Abbreviations	95
Table 25.	Write-display-data - write display data command bit description	24	Table 60.	Revision history	97
Table 26.	Input-bank-select - input bank select command bit description	24			
Table 27.	Output-bank-select - output bank select command bit description	25			
Table 28.	Data-pointer - set data pointer command bit description	25			
Table 29.	Selection of possible display configurations	32			
Table 30.	Parameters of V _{LCD} generation	35			
Table 31.	Output resistance of the charge pump	37			
Table 32.	Temperature regions	42			
Table 33.	Temperature coefficients	43			
Table 34.	Calculation of the temperature compensated value VT	43			
Table 35.	LCD drive modes: summary of characteristics	44			

27. Figures

Fig 1. Block diagram of PCA8530	4	Fig 29. Display RAM bitmap and bank definition	53
Fig 2. Pinning diagram of PCA8530DUG.	5	Fig 30. Bank selection in multiplex drive mode 1:2.	54
Fig 3. Recommended start-up sequence when using the internal charge pump and the internal clock signal	27	Fig 31. Example of the Bank-select command with multiplex drive mode 1:2	54
Fig 4. Recommended start-up sequence when using an external supplied V _{LCD} and the internal clock signal	27	Fig 32. Control byte format	56
Fig 5. Recommended start-up sequence when using the internal charge pump and an external clock signal	28	Fig 33. I ² C-bus - bit transfer	57
Fig 6. Recommended start-up sequence when using an external supplied V _{LCD} and an external clock signal	28	Fig 34. I ² C-bus - definition of START and STOP conditions	58
Fig 7. Recommended power-down sequence for minimum power-down current when using the internal charge pump and the internal clock signal.	29	Fig 35. I ² C-bus - system configuration	58
Fig 8. Recommended power-down sequence when using an external supplied V _{LCD} and the internal clock signal	30	Fig 36. Acknowledgement on the I ² C-bus.	59
Fig 9. Recommended power-down sequence when using the internal charge pump and an external clock signal	30	Fig 37. I ² C-bus protocol - write mode	60
Fig 10. Recommended power-down sequence when using an external supplied V _{LCD} and an external clock signal	31	Fig 38. I ² C-bus protocol - read mode	60
Fig 11. Example of display types suitable for PCA8530	32	Fig 39. SPI-bus protocol - data transfer overview	61
Fig 12. Typical system configuration if using the internal V _{LCD} generation and I ² C-bus	33	Fig 40. SPI-bus example.	62
Fig 13. Typical system configuration if using the external V _{LCD} and SPI-bus	33	Fig 41. SPI-bus protocol - read example.	62
Fig 14. V _{LCD} generation including temperature compensation	35	Fig 42. SPI-bus protocol - write example	62
Fig 15. V _{LCD} programming of PCA8530 (assuming VT[8:0] = 0h)	36	Fig 43. Device protection diagram	63
Fig 16. Charge pump model (used to characterize the driving strength)	36	Fig 44. Typical I _{DD1} with respect to temperature	69
Fig 17. Charge pump driving capability with V _{DD2} = 3.0 V.	37	Fig 45. Typical I _{DD2} with respect to temperature	69
Fig 18. Charge pump driving capability with V _{DD2} = 5.0 V.	38	Fig 46. Typical I _{DD3} with respect to temperature	70
Fig 19. V _{LCD} with respect to I _{load} at V _{DD2} = 3 V	39	Fig 47. Typical I _{DD(LCD)} with respect to temperature	70
Fig 20. V _{LCD} with respect to I _{load} at V _{DD2} = 5 V	39	Fig 48. Typical V _{LCD} variation with respect to temperature.	71
Fig 21. Temperature measurement block with digital temperature filter	40	Fig 49. Typical frame frequency variation with respect to temperature.	71
Fig 22. Temperature measurement delay	41	Fig 50. Measurement temperature variation with respect to temperature	72
Fig 23. Example of segmented temperature coefficients.	42	Fig 51. Driver timing waveforms	73
Fig 24. Electro-optical characteristic: relative transmission curve of the liquid.	45	Fig 52. I ² C-bus timing	75
Fig 25. Static drive mode waveforms, line inversion mode (n = 1)	46	Fig 53. SPI-bus timing.	76
Fig 26. Waveforms for the 1:2 multiplex drive mode, 1/2 bias, line inversion mode (n = 1)	47	Fig 54. Recommended ITO connections for the I ² C interface	78
Fig 27. Waveforms for the 1:2 multiplex drive mode, 1/3 bias, line inversion mode (n = 1)	48	Fig 55. Recommended ITO connections for the SPI interface	79
Fig 28. Waveforms for the 1:4 multiplex drive mode, 1/3 bias, line inversion mode (n = 1).	49	Fig 56. Cascaded configuration with two PCA8530 with external V _{LCD} and internal clock	81
		Fig 57. Cascaded configuration with two PCA8530 with internal V _{LCD} and external clock	82
		Fig 58. Cascade configuration for data reading	84
		Fig 59. Bare die outline of PCA8530DUG	85
		Fig 60. Alignment marks	89
		Fig 61. Tray details of PCA8530DUG	91
		Fig 62. Die alignment in the tray	92

28. Contents

1	General description	1	8.7.2	Bank select commands	24
2	Features and benefits	1	8.7.2.1	Command: Input-bank-select	24
3	Applications	2	8.7.2.2	Command: Output-bank-select	25
4	Ordering information	3	8.7.3	Command: Data-pointer	25
4.1	Ordering options	3	8.8	Start-up and shut-down	26
5	Marking	3	8.8.1	Power-On	26
6	Block diagram	4	8.8.2	Recommended start-up sequences	26
7	Pinning information	5	8.8.3	Recommended power-down sequences	29
7.1	Pinning	5	8.9	Possible display configurations	32
7.2	Pin description	6	8.10	LCD voltage	34
8	Functional description	8	8.10.1	V _{LCD} pins	34
8.1	Commands of PCA8530	8	8.10.2	External V _{LCD} supply	34
8.2	General control commands	10	8.10.3	Internal V _{LCD} generation	34
8.2.1	Initialization	10	8.10.3.1	V _{LCD} programming	34
8.2.1.1	Command: Initialize	10	8.10.3.2	V _{LCD} driving capability	36
8.2.1.2	RST pin	10	8.10.4	Temperature measurement and temperature compensation of V _{LCD}	40
8.2.2	Command: OTP-refresh	10	8.10.4.1	Temperature readout	40
8.2.3	Command: Device-address	11	8.10.4.2	Temperature adjustment of the V _{LCD}	41
8.2.4	Command: SYNC1_pin	11	8.10.5	LCD voltage selector	44
8.2.5	Command: Clock-out-ctrl	12	8.10.5.1	Electro-optical performance	45
8.2.6	Command: Read-select	12	8.10.6	LCD drive mode waveforms	46
8.2.7	Command: Status-readout	13	8.10.6.1	Static drive mode	46
8.2.8	Command: Clear-reset-flag	14	8.10.6.2	1:2 Multiplex drive mode	47
8.3	Charge pump and LCD bias control commands	15	8.10.6.3	1:4 Multiplex drive mode	49
8.3.1	Command: Charge-pump-ctrl	15	8.11	Backplane outputs	50
8.3.2	Command: Set-V _{LCD}	15	8.11.1	Driving strength on the backplanes	50
8.3.3	Command: Set-bias-mode	16	8.12	Segment outputs	50
8.4	Temperature compensation control commands	17	8.13	Display register	50
8.4.1	Command: Temperature-ctrl	17	8.14	Display RAM	51
8.4.2	Command: TC-set	18	8.14.1	Data pointer	51
8.4.3	Command: TC-slope	19	8.14.1.1	Data pointer in cascade configuration	51
8.5	Display control commands	20	8.14.2	RAM filling	52
8.5.1	Command: Set-MUX-mode	20	8.14.2.1	RAM filling in static drive mode	52
8.5.2	Command: Inversion-mode	20	8.14.2.2	RAM filling in 1:2 multiplex drive mode	52
8.5.2.1	Line inversion mode (driving scheme A)	20	8.14.2.3	RAM filling in 1:4 multiplex drive mode	53
8.5.2.2	Frame inversion mode (driving scheme B)	21	8.14.3	Bank selection	53
8.5.3	Command: Display-ctrl	21	8.14.3.1	Input-bank-select	54
8.6	Clock and frame frequency command	22	8.14.3.2	Output-bank-select	54
8.6.1	Oscillator	22	9	Bus interfaces	56
8.6.2	External clock	22	9.1	Control byte and register selection	56
8.6.3	Internal clock	22	9.2	I ² C interface	57
8.6.4	Command: Frame-frequency	22	9.2.1	Bit transfer	57
8.7	Display RAM commands	24	9.2.2	START and STOP conditions	57
8.7.1	Command: Write-display-data	24	9.2.3	System configuration	58
			9.2.4	Acknowledge	58
			9.2.5	I ² C-bus controller	59
			9.2.6	Input filters	59

continued >>

9.2.7	I ² C-bus slave address	59
9.2.8	I ² C-bus protocol	60
9.3	SPI interface	61
9.3.1	Data transmission	61
10	Internal circuitry	63
11	Safety notes	64
12	Limiting values	65
13	Static characteristics	66
14	Dynamic characteristics	73
14.1	General dynamic characteristics	73
14.2	I ² C-bus timing characteristics	74
14.3	SPI-bus timing characteristics	75
15	Application information	77
15.1	ITO layout recommendations for ESD/EMC robustness in COG applications	77
15.2	Cascaded operation	80
15.2.1	Wiring backplane and segment outputs	80
15.2.2	Device synchronization	82
15.2.3	Display data	83
15.2.4	Data read	83
16	Test information	84
16.1	Quality information	84
17	Bare die outline	85
18	Handling information	90
19	Packing information	91
19.1	Tray information	91
20	Appendix	93
20.1	LCD segment driver selection	93
21	Abbreviations	95
22	References	96
23	Revision history	97
24	Legal information	98
24.1	Data sheet status	98
24.2	Definitions	98
24.3	Disclaimers	98
24.4	Trademarks	99
25	Contact information	99
26	Tables	100
27	Figures	101
28	Contents	102

Please be aware that important notices concerning this document and the product(s) described herein, have been included in section 'Legal information'.

© NXP Semiconductors N.V. 2014.

All rights reserved.

For more information, please visit: <http://www.nxp.com>

For sales office addresses, please send an email to: salesaddresses@nxp.com

Date of release: 25 September 2014

Document identifier: PCA8530

Looking for pricing, stock, or lifecycle information?

Click below to explore more details on WIN SOURCE:

- ⊖ [View PCA8530DUG/DAZ on WIN SOURCE](#)
- ⊖ [NXP / Nexperia Information](#)

Optimize Your Supply Chain with WIN SOURCE Solutions

- ✓ Global Sourcing Solution
- ✓ Obsolete Management
- ✓ Cost Control Management
- ✓ Shortage Management
- ✓ Alternative Solution
- ✓ Excess Inventory Management