



**THE DATASHEET OF  
PCA85063ATT/AJ**





# PCA85063A

## Automotive tiny Real-Time Clock/calendar with alarm function and I<sup>2</sup>C-bus

Rev. 4 — 30 March 2018

Product data sheet

### 1. General description

---

The PCA85063A is a CMOS<sup>1</sup> Real-Time Clock (RTC) and calendar optimized for low power consumption. An offset register allows fine-tuning of the clock. All addresses and data are transferred serially via the two-line bidirectional I<sup>2</sup>C-bus. Maximum data rate is 400 kbit/s. The register address is incremented automatically after each written or read data byte.

For a selection of NXP Real-Time Clocks, see [Table 45 on page 50](#)

### 2. Features and benefits

---

- AEC-Q100 grade 2 compliant for automotive applications
- Provides year, month, day, weekday, hours, minutes, and seconds based on a 32.768 kHz quartz crystal
- Low current; typical 0.25  $\mu$ A at  $V_{DD} = 3.0$  V and  $T_{amb} = 25$  °C
- Programmable clock output for peripheral devices (32.768 kHz, 16.384 kHz, 8.192 kHz, 4.096 kHz, 2.048 kHz, 1.024 kHz, and 1 Hz)
- Alarm function
- Minute and half minute interrupt
- Internal Power-On Reset (POR)
- High temperature operation range:  $-40$  °C to  $+105$  °C
- Clock operating voltage: 0.9 V to 5.5 V
- 400 kHz two-line I<sup>2</sup>C-bus interface (at  $V_{DD} = 1.8$  V to 5.5 V)
- Selectable integrated oscillator load capacitors for  $C_L = 7$  pF or  $C_L = 12.5$  pF
- Countdown timer
- Oscillator stop detection function
- Programmable offset register for frequency adjustment

### 3. Applications

---

- Tracking time of the day
- Dashboard
- Air condition
- Telematics
- Accurate timing
- Infotainment unit
- Center stack
- Body control and battery management

---

1. The definition of the abbreviations and acronyms used in this data sheet can be found in [Section 22](#).



## 4. Ordering information

Table 1. Ordering information

Type number	Package		
	Name	Description	Version
PCA85063ATT	TSSOP8	plastic thin shrink small outline package; 8 leads; body width 3 mm	SOT505-1

### 4.1 Ordering options

Table 2. Ordering options

Product type number	Orderable part number	Sales item (12NC)	Delivery form	IC revision
PCA85063ATT/A	PCA85063ATT/AJ	935305541118	tape and reel, 13 inch	1

## 5. Marking

Table 3. Marking codes

Product type number	Marking code
PCA85063ATT/A	063Q

## 6. Block diagram

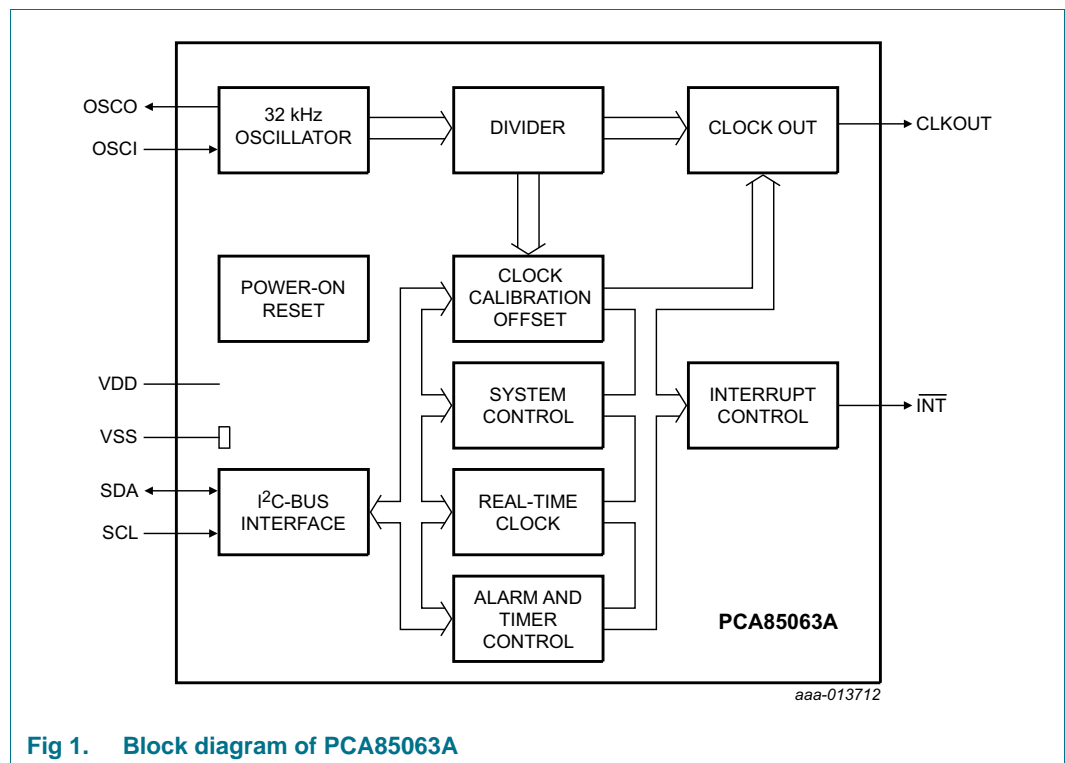
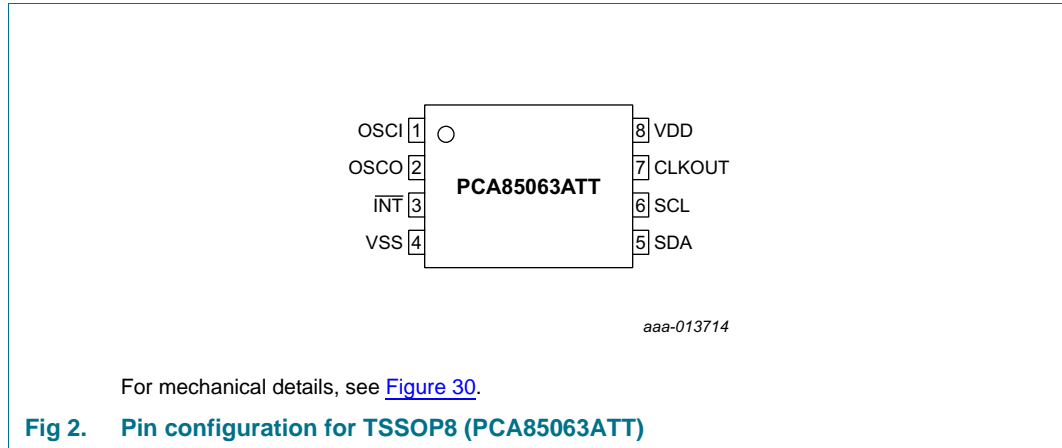

Fig 1. Block diagram of PCA85063A

## 7. Pinning information

### 7.1 Pinning



### 7.2 Pin description

**Table 4. Pin description**

*Input or input/output pins must always be at a defined level ( $V_{SS}$  or  $V_{DD}$ ) unless otherwise specified.*

Symbol	Pin	Type	Description
	PCA85063ATT		
OSCI	1	input	oscillator input
OSCO	2	output	oscillator output
$\overline{\text{INT}}$ <sup>[1]</sup>	3	output	interrupt output (open-drain)
VSS	4	supply	ground supply voltage
SDA <sup>[1]</sup>	5	input/output	serial data line
SCL <sup>[1]</sup>	6	input	serial clock input
CLKOUT	7	output	clock output (push-pull)
VDD	8	supply	supply voltage

[1] NXP recommends tying VDD of the device and VDD of all the external pull-up resistors to the same Power Supply.

## 8. Functional description

The PCA85063A contains 18 8-bit registers with an auto-incrementing register address, an on-chip 32.768 kHz oscillator with integrated capacitors, a frequency divider which provides the source clock for the Real-Time Clock (RTC) and calendar, and an I<sup>2</sup>C-bus interface with a maximum data rate of 400 kbit/s.

The built-in address register will increment automatically after each read or write of a data byte up to the register 11h. After register 11h, the auto-incrementing will wrap around to address 00h (see [Figure 3](#)).

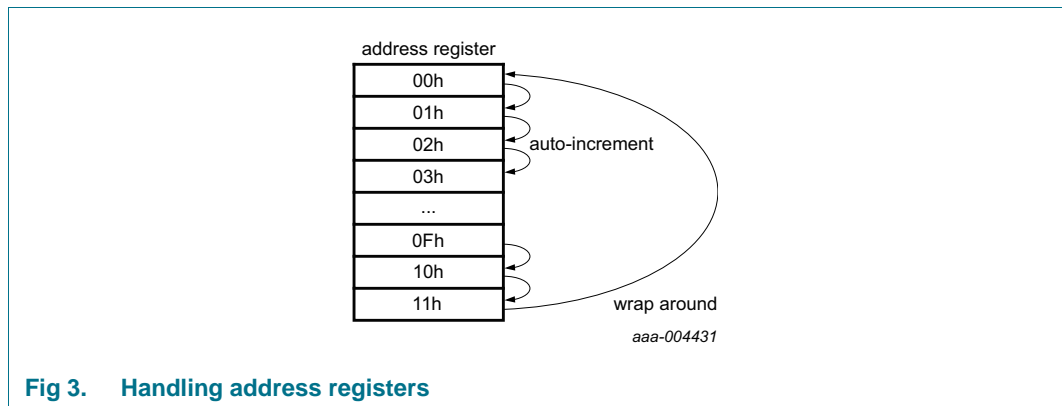

**Fig 3. Handling address registers**

All registers (see [Table 5](#)) are designed as addressable 8-bit parallel registers although not all bits are implemented. The first two registers (memory address 00h and 01h) are used as control and status register. The register at address 02h is an offset register allowing the fine-tuning of the clock; and at 03h is a free RAM byte. The addresses 04h through 0Ah are used as counters for the clock function (seconds up to years counters). Address locations 0Bh through 0Fh contain alarm registers which define the conditions for an alarm. The registers at 10h and 11h are for the timer function.

The Seconds, Minutes, Hours, Days, Months, and Years as well as the corresponding alarm registers are all coded in Binary Coded Decimal (BCD) format. When one of the RTC registers is written or read, the contents of all time counters are frozen. Therefore, faulty writing or reading of the clock and calendar during a carry condition is prevented. For details on maximum access time, see [Section 8.4 on page 23](#).

## 8.1 Registers organization

**Table 5. Registers overview**  
*Bit positions labeled as - are not implemented. After reset, all registers are set according to [Table 8 on page 10](#).*

Address	Register name	Bit	7	6	5	4	3	2	1	0
<b>Control and status registers</b>										
00h	Control_1	EXT_TEST	-	-	STOP	SR	-	CIE	12_24	CAP_SE
01h	Control_2	AIE	AF	MI		HMI	TF	COF[2:0]		
02h	Offset	MODE	OFFSET[6:0]							
03h	RAM_byte	RAM_byte	B[7:0]							
<b>Time and date registers</b>										
04h	Seconds	OS	SECONDS (0 to 59)							
05h	Minutes	-	MINUTES (0 to 59)							
06h	Hours	-	-	AMPM	HOURS (1 to 12) in 12-hour mode					
07h	Days	-	HOURS (0 to 23) in 24-hour mode							
08h	Weekdays	-	DAYS (1 to 31)							
09h	Months	-	-	-	-	WEEKDAYS (0 to 6)				
0Ah	Years	-	MONTHS (1 to 12)							
0Ah	Years	YEARS	(0 to 99)							
<b>Alarm registers</b>										
0Bh	Second_alarm	AEN_S	SECOND_ALARM (0 to 59)							
0Ch	Minute_alarm	AEN_M	MINUTE_ALARM (0 to 59)							
0Dh	Hour_alarm	AEN_H	-	AMPM	HOUR_ALARM (1 to 12) in 12-hour mode					
0Eh	Day_alarm	AEN_D	-	HOUR_ALARM (0 to 23) in 24-hour mode						
0Fh	Weekday_alarm	AEN_W	-	-	-	DAY_ALARM (1 to 31)				
0Fh	Weekday_alarm	AEN_W	-	-	-	WEEKDAY_ALARM (0 to 6)				
<b>Timer registers</b>										
10h	Timer_value	T[7:0]								
11h	Timer_mode	-	-	-	-	TCF[1:0]	TE	TIE	TI_TP	

## 8.2 Control registers

To ensure that all control registers will be set to their default values, the V<sub>DD</sub> level must be at zero volts at initial power-up. If this is not possible, a reset must be initiated with the software reset command when power is stable. Refer to [Section 8.2.1.3](#) for details.

### 8.2.1 Register Control\_1

Table 6. Control\_1 - control and status register 1 (address 00h) bit description

Bit	Symbol	Value	Description	Reference
7	EXT_TEST		<b>external clock test mode</b>	<a href="#">Section 8.2.1.1</a>
		0 <sup>[1]</sup>	normal mode	
		1	external clock test mode	
6	-	0	unused	-
5	STOP		<b>STOP bit</b>	<a href="#">Section 8.2.1.2</a>
		0 <sup>[1]</sup>	RTC clock runs	
		1	RTC clock is stopped; all RTC divider chain flip-flops are asynchronously set logic 0	
4	SR		<b>software reset</b>	<a href="#">Section 8.2.1.3</a>
		0 <sup>[1]</sup>	no software reset	
		1	initiate software reset <sup>[2]</sup> ; this bit always returns a 0 when read	
3	-	0	unused	-
2	CIE		<b>correction interrupt enable</b>	<a href="#">Section 8.2.3</a>
		0 <sup>[1]</sup>	no correction interrupt generated	
		1	interrupt pulses are generated at every correction cycle	
1	12_24		<b>12 or 24-hour mode</b>	<a href="#">Section 8.3.3</a> <a href="#">Section 8.5.3</a>
		0 <sup>[1]</sup>	24-hour mode is selected	
		1	12-hour mode is selected	
0	CAP_SEL		<b>internal oscillator capacitor selection</b> for quartz crystals with a corresponding load capacitance	-
		0 <sup>[1]</sup>	7 pF	
		1	12.5 pF	

[1] Default value.

[2] For a software reset, 01011000 (58h) must be sent to register Control\_1 (see [Section 8.2.1.3](#)).

### 8.2.1.1 EXT\_TEST: external clock test mode

A test mode is available which allows for on-board testing. In this mode, it is possible to set up test conditions and control the operation of the RTC.

The test mode is entered by setting bit EXT\_TEST in register Control\_1. Then pin CLKOUT becomes an input. The test mode replaces the internal clock signal with the signal applied to pin CLKOUT.

The signal applied to pin CLKOUT should have a minimum pulse width of 300 ns and a maximum period of 1 000 ns. The internal clock, now sourced from CLKOUT, is divided down to 1 Hz by a 2<sup>6</sup> divide chain called a prescaler. The prescaler can be set into a known state by using bit STOP. When bit STOP is set, the prescaler is reset to 0. (STOP must be cleared before the prescaler can operate again.)

From a stop condition, the first 1 second increment will take place after 32 positive edges on pin CLKOUT. Thereafter, every 64 positive edges cause a 1 second increment.

**Remark:** Entry into test mode is not synchronized to the internal 64 Hz clock. When entering the test mode, no assumption as to the state of the prescaler can be made.

Operation example:

1. Set EXT\_TEST test mode (register Control\_1, bit EXT\_TEST = 1).
2. Set STOP (register Control\_1, bit STOP = 1).
3. Clear STOP (register Control\_1, bit STOP = 0).
4. Set time registers to desired value.
5. Apply 32 clock pulses to pin CLKOUT.
6. Read time registers to see the first change.
7. Apply 64 clock pulses to pin CLKOUT.
8. Read time registers to see the second change.

Repeat 7 and 8 for additional increments.

8.2.1.2 STOP: STOP bit function

The function of the STOP bit (see [Figure 4](#)) is to allow for accurate starting of the time circuits. The STOP bit function causes the upper part of the prescaler (F<sub>2</sub> to F<sub>14</sub>) to be held in reset and thus no 1 Hz ticks are generated. It also stops the output of clock frequencies below 8 kHz on pin CLKOUT.

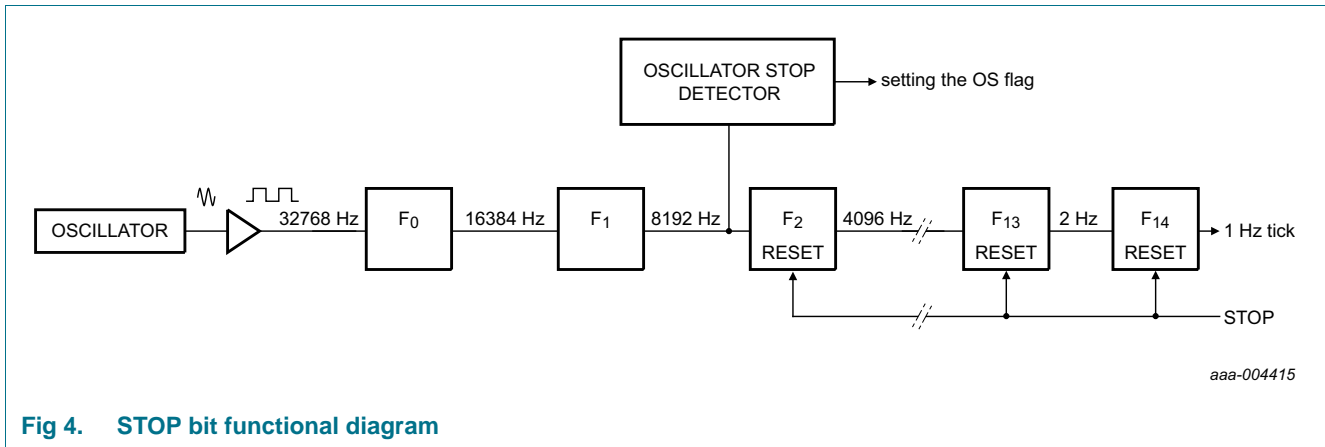

Fig 4. STOP bit functional diagram

The time circuits can then be set and do not increment until the STOP bit is released (see [Figure 5](#) and [Table 7](#)).

Table 7. First increment of time circuits after STOP bit release

Bit	Prescaler bits	[1] 1 Hz tick	Time	Comment
STOP	F <sub>0</sub> F <sub>1</sub> -F <sub>2</sub> to F <sub>14</sub>		hh:mm:ss	
<b>Clock is running normally</b>				
0	01-0 0001 1101 0100		12:45:12	prescaler counting normally
<b>STOP bit is activated by user. F<sub>0</sub>F<sub>1</sub> are not reset and values cannot be predicted externally</b>				
1	XX-0 0000 0000 0000		12:45:12	prescaler is reset; time circuits are frozen
<b>New time is set by user</b>				
1	XX-0 0000 0000 0000		08:00:00	prescaler is reset; time circuits are frozen
<b>STOP bit is released by user</b>				
0	XX-0 0000 0000 0000		08:00:00	prescaler is now running
	XX-1 0000 0000 0000		08:00:00	-
	XX-0 1000 0000 0000		08:00:00	-
	XX-1 1000 0000 0000		08:00:00	-
	:		:	-
	11-1 1111 1111 1110		08:00:00	-
	00-0 0000 0000 0001		08:00:01	0 to 1 transition of F <sub>14</sub> increments the time circuits
	10-0 0000 0000 0001		08:00:01	-
	:		:	-
	11-1 1111 1111 1111		08:00:01	-
	00-0 0000 0000 0000		08:00:01	-
	10-0 0000 0000 0000		08:00:01	-
	:		:	-
	11-1 1111 1111 1110		08:00:01	-
	00-0 0000 0000 0001		08:00:02	0 to 1 transition of F <sub>14</sub> increments the time circuits

[1] F<sub>0</sub> is clocked at 32.768 kHz.

The lower two stages of the prescaler (F<sub>0</sub> and F<sub>1</sub>) are not reset. And because the I<sup>2</sup>C-bus is asynchronous to the crystal oscillator, the accuracy of restarting the time circuits is between zero and one 8.192 kHz cycle (see [Figure 5](#)).

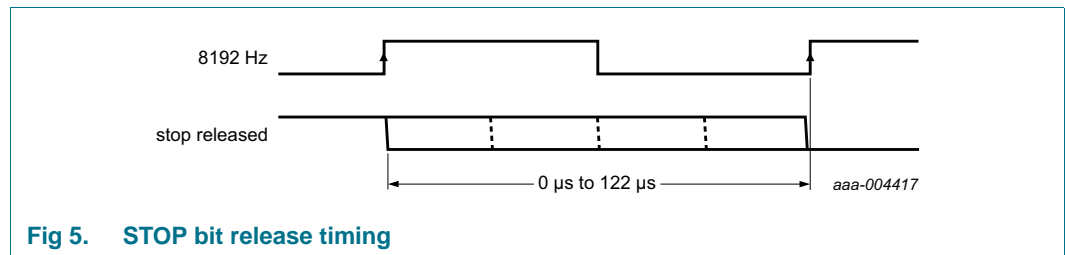
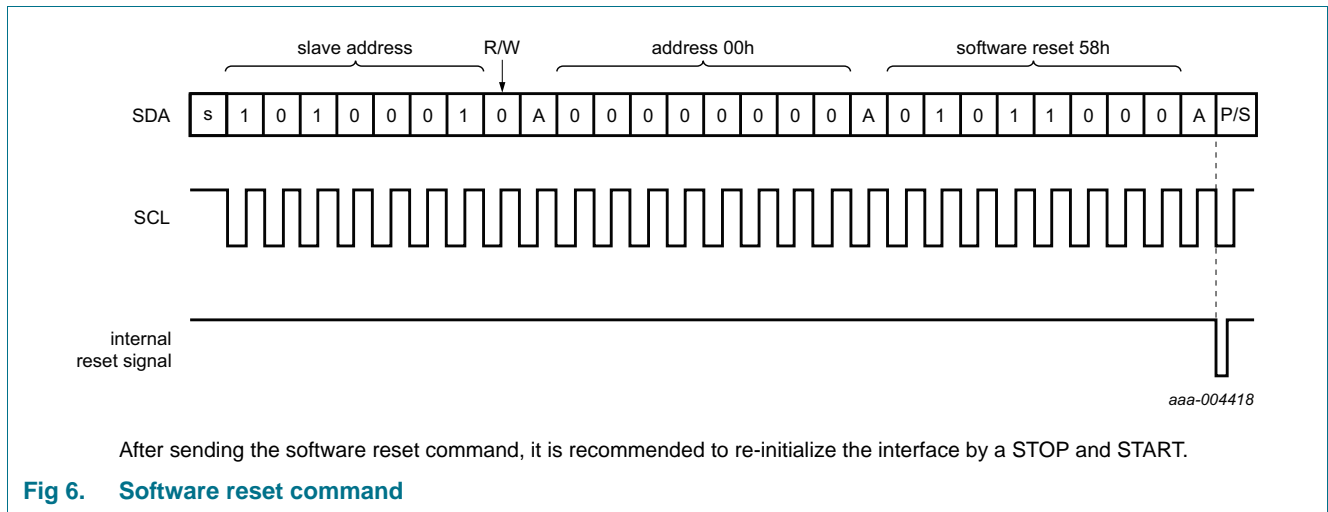

Fig 5. STOP bit release timing

The first increment of the time circuits is between 0.507813 s and 0.507935 s after STOP bit is released. The uncertainty is caused by the prescaler bits F<sub>0</sub> and F<sub>1</sub> not being reset (see [Table 7](#)) and the unknown state of the 32 kHz clock.

8.2.1.3 Software reset

A reset is automatically generated at power-on. There is a low probability that some devices will have corruption of the registers after the automatic power-on reset if the device is powered up with a residual V<sub>DD</sub> level. It is required that the V<sub>DD</sub> starts at zero volts at power up or upon power cycling to ensure that there is no corruption of the registers. If this is not possible, a reset must be initiated after power-up (i.e. when power is stable) with the software reset command. Software reset command means setting bits 6, 4, and 3 in register Control\_1 (00h) logic 1 and all other bits logic 0 by sending the bit sequence 01011000 (58h), see [Figure 6](#).



In reset state, all registers are set according to [Table 8](#) and the address pointer returns to address 00h.

**Table 8. Registers reset values**

Address	Register name	Bit							
		7	6	5	4	3	2	1	0
00h	Control_1	0	0	0	0	0	0	0	0
01h	Control_2	0	0	0	0	0	0	0	0
02h	Offset	0	0	0	0	0	0	0	0
03h	RAM_byte	0	0	0	0	0	0	0	0
04h	Seconds	1	0	0	0	0	0	0	0
05h	Minutes	0	0	0	0	0	0	0	0
06h	Hours	0	0	0	0	0	0	0	0
07h	Days	0	0	0	0	0	0	0	1
08h	Weekdays	0	0	0	0	0	1	1	0
09h	Months	0	0	0	0	0	0	0	1
0Ah	Years	0	0	0	0	0	0	0	0
0Bh	Second_alarm	1	0	0	0	0	0	0	0
0Ch	Minute_alarm	1	0	0	0	0	0	0	0
0Dh	Hour_alarm	1	0	0	0	0	0	0	0
0Eh	Day_alarm	1	0	0	0	0	0	0	0

**Table 8. Registers reset values ...continued**

Address	Register name	Bit							
		7	6	5	4	3	2	1	0
0Fh	Weekday_alarm	1	0	0	0	0	0	0	0
10h	Timer_value	0	0	0	0	0	0	0	0
11h	Timer_mode	0	0	0	1	1	0	0	0

The PCA85063A resets to:

**Time** — 00:00:00

**Date** — 20000101

**Weekday** — Saturday

### 8.2.2 Register Control\_2

**Table 9. Control\_2 - control and status register 2 (address 01h) bit description**

Bit	Symbol	Value	Description	Reference
7	AIE		<b>alarm interrupt</b>	<a href="#">Section 8.2.2.1</a> <a href="#">Section 8.5.6</a>
		0 <sup>[1]</sup>	disabled	
		1	enabled	
6	AF		<b>alarm flag</b>	<a href="#">Section 8.2.2.1</a> <a href="#">Section 8.5.6</a>
		0 <sup>[1]</sup>	read: alarm flag inactive write: alarm flag is cleared	
		1	read: alarm flag active	
			write: alarm flag remains unchanged	
5	MI		<b>minute interrupt</b>	<a href="#">Section 8.2.2.2</a> <a href="#">Section 8.2.2.3</a>
		0 <sup>[1]</sup>	disabled	
		1	enabled	
4	HMI		<b>half minute interrupt</b>	<a href="#">Section 8.2.2.2</a> <a href="#">Section 8.2.2.3</a>
		0 <sup>[1]</sup>	disabled	
		1	enabled	
3	TF		<b>timer flag</b>	<a href="#">Section 8.2.2.1</a> <a href="#">Section 8.2.2.3</a> <a href="#">Section 8.6.3</a>
		0 <sup>[1]</sup>	no timer interrupt generated	
		1	flag set when timer interrupt generated	
2 to 0	COF[2:0]	see <a href="#">Table 11</a>	<b>CLKOUT control</b>	<a href="#">Section 8.2.2.4</a>

[1] Default value.

8.2.2.1 Alarm interrupt

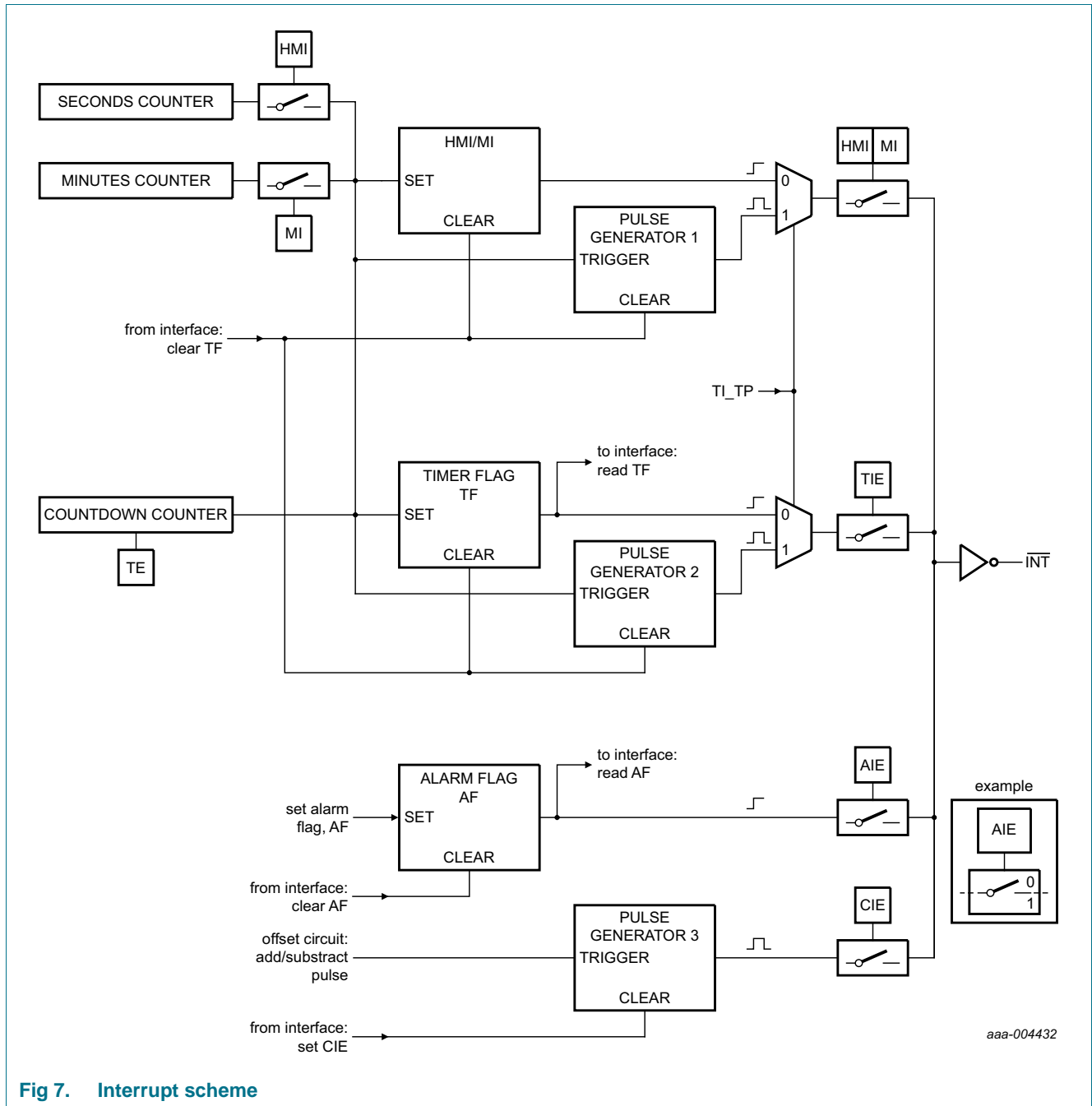

Fig 7. Interrupt scheme

**AIE:** This bit activates or deactivates the generation of an interrupt when AF is asserted, respectively.

**AF:** When an alarm occurs, AF is set logic 1. This bit maintains its value until overwritten by command. To prevent one flag being overwritten while clearing another, a logic AND is performed during a write access.

8.2.2.2 MI and HMI: minute and half minute interrupt

The minute interrupt (bit MI) and half minute interrupt (bit HMI) are pre-defined timers for generating interrupt pulses on pin  $\overline{\text{INT}}$ ; see Figure 8. The timers are running in sync with the seconds counter (see Table 19 on page 19).

The minute and half minute interrupts must only be used when the frequency offset is set to normal mode (MODE = 0), see Section 8.2.3. In normal mode, the interrupt pulses on pin  $\overline{\text{INT}}$  are  $\frac{1}{64}$  s wide.

When starting MI, the first interrupt will be generated after 1 second to 59 seconds. When starting HMI, the first interrupt will be generated after 1 second to 29 seconds. Subsequent periods do not have such a delay. The timers can be enabled independently from one another. However, a minute interrupt enabled on top of a half minute interrupt is not distinguishable.

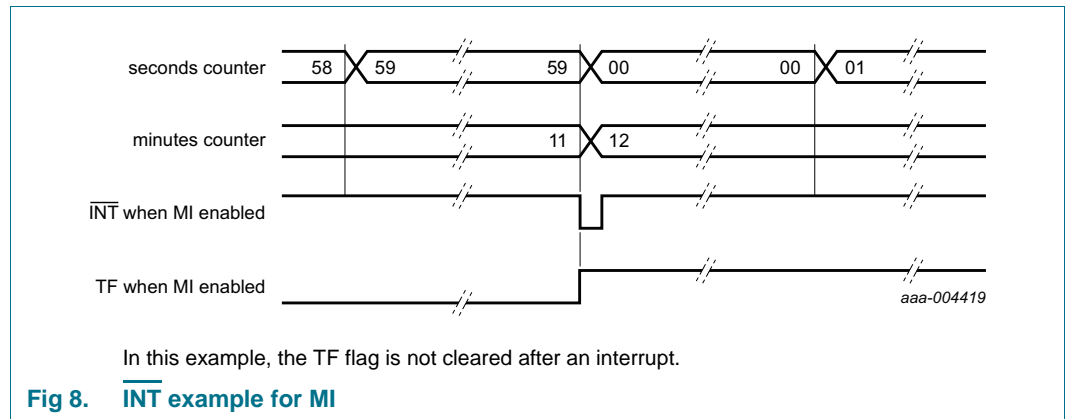

Table 10. Effect of bits MI and HMI on  $\overline{\text{INT}}$  generation

Minute interrupt (bit MI)	Half minute interrupt (bit HMI)	Result
0	0	no interrupt generated
1	0	an interrupt every minute
0	1	an interrupt every 30 s
1	1	an interrupt every 30 s

The duration of the timer is affected by the register Offset (see Section 8.2.3). Only when OFFSET[6:0] has the value 00h the periods are consistent.

8.2.2.3 TF: timer flag

The timer flag (bit TF) is set logic 1 on the first trigger of MI, HMI, or the countdown timer. The purpose of the flag is to allow the controlling system to interrogate what caused the interrupt: timer or alarm. The flag can be read and cleared by command.

The status of the timer flag TF can affect the  $\overline{\text{INT}}$  pulse generation depending on the setting of TI\_TP (see Section 8.6.2 “Register Timer\_mode” on page 28):

- When TI\_TP is set logic 1
  - an  $\overline{\text{INT}}$  pulse is generated independent of the status of the timer flag TF
  - TF stays set until it is cleared
  - TF does not affect  $\overline{\text{INT}}$

- the countdown timer runs in a repetitive loop and keeps generating timed periods
- When TI\_TP is set logic 0
  - the  $\overline{\text{INT}}$  generation follows the TF flag
  - TF stays set until it is cleared
  - If TF is not cleared before the next coming interrupt, no  $\overline{\text{INT}}$  is generated
  - the countdown timer stops after the first countdown

**8.2.2.4 COF[2:0]: Clock output frequency**

A programmable square wave is available at pin CLKOUT. Operation is controlled by the COF[2:0] bits in the register Control\_2. Frequencies of 32.768 kHz (default) down to 1 Hz can be generated for use as a system clock, microcontroller clock, input to a charge pump, or for calibration of the oscillator.

Pin CLKOUT is a push-pull output and enabled at power-on. CLKOUT can be disabled by setting COF[2:0] to 111. When disabled, the CLKOUT is LOW.

The duty cycle of the selected clock is not controlled. However, due to the nature of the clock generation, all clock frequencies except 32.768 kHz have a duty cycle of 50 : 50.

The STOP bit function can also affect the CLKOUT signal, depending on the selected frequency. When the STOP bit is set logic 1, the CLKOUT pin generates a continuous LOW for those frequencies that can be stopped. For more details of the STOP bit function, see [Section 8.2.1.2](#).

**Table 11. CLKOUT frequency selection**

COF[2:0]	CLKOUT frequency (Hz)	Typical duty cycle <sup>[1]</sup>	Effect of STOP bit
000 <sup>[2]</sup>	32768	60 : 40 to 40 : 60	no effect
001	16384	50 : 50	no effect
010	8192	50 : 50	no effect
011	4096	50 : 50	CLKOUT = LOW
100	2048	50 : 50	CLKOUT = LOW
101	1024	50 : 50	CLKOUT = LOW
110	1 <sup>[3]</sup>	50 : 50	CLKOUT = LOW
111	CLKOUT = LOW	-	-

[1] Duty cycle definition: % HIGH-level time : % LOW-level time.

[2] Default value.

[3] 1 Hz clock pulses are affected by offset correction pulses.

### 8.2.3 Register Offset

The PCA85063A incorporates an offset register (address 02h) which can be used to implement several functions, such as:

- Accuracy tuning
- Aging adjustment
- Temperature compensation

**Table 12. Offset - offset register (address 02h) bit description**

Bit	Symbol	Value	Description
7	MODE		<b>offset mode</b>
		0 <sup>[1]</sup>	normal mode: offset is made once every two hours
		1	course mode: offset is made every 4 minutes
6 to 0	OFFSET[6:0]	see <a href="#">Table 13</a>	<b>offset value</b>

[1] Default value.

For MODE = 0, each LSB introduces an offset of 4.34 ppm. For MODE = 1, each LSB introduces an offset of 4.069 ppm. The offset value is coded in two's complement giving a range of +63 LSB to -64 LSB.

**Table 13. Offset values**

OFFSET[6:0]	Offset value in decimal	Offset value in ppm	
		Normal mode MODE = 0	Fast mode MODE = 1
0111111	+63	+273.420	+256.347
0111110	+62	+269.080	+252.278
:	:	:	:
0000010	+2	+8.680	+8.138
0000001	+1	+4.340	+4.069
0000000 <sup>[1]</sup>	0	0 <sup>[1]</sup>	0 <sup>[1]</sup>
1111111	-1	-4.340	-4.069
1111110	-2	-8.680	-8.138
:	:	:	:
1000001	-63	-273.420	-256.347
1000000	-64	-277.760	-260.416

[1] Default value.

The correction is made by adding or subtracting clock correction pulses, thereby changing the period of a single second but not by changing the oscillator frequency.

It is possible to monitor when correction pulses are applied. To enable correction interrupt generation, bit CIE (register Control\_1) has to be set logic 1. At every correction cycle, a pulse is generated on pin INT. The pulse width depends on the correction mode. If multiple correction pulses are applied, an interrupt pulse is generated for each correction pulse applied.

### 8.2.3.1 Correction when MODE = 0

The correction is triggered once every two hours and then correction pulses are applied once per minute until the programmed correction values have been implemented.

**Table 14. Correction pulses for MODE = 0**

Correction value	Update every n <sup>th</sup> hour	Minute	Correction pulses on $\overline{\text{INT}}$ per minute <sup>[1]</sup>
+1 or -1	2	00	1
+2 or -2	2	00 and 01	1
+3 or -3	2	00, 01, and 02	1
:	:	:	:
+59 or -59	2	00 to 58	1
+60 or -60	2	00 to 59	1
+61 or -61	2	00 to 59	1
	2nd and next hour	00	1
+62 or -62	2	00 to 59	1
	2nd and next hour	00 and 01	1
+63 or -63	02	00 to 59	1
	2nd and next hour	00, 01, and 02	1
-64	02	00 to 59	1
	2nd and next hour	00, 01, 02, and 03	1

[1] The correction pulses on pin  $\overline{\text{INT}}$  are  $\frac{1}{64}$  s wide.

In MODE = 0, any timer or clock output using a frequency below 64 Hz is affected by the clock correction (see [Table 15](#)).

**Table 15. Effect of correction pulses on frequencies for MODE = 0**

Frequency (Hz)	Effect of correction
<b>CLKOUT</b>	
32768	no effect
16384	no effect
8192	no effect
4096	no effect
2048	no effect
1024	no effect
1	affected
<b>Timer source clock</b>	
4096	no effect
64	no effect
1	affected
$\frac{1}{60}$	affected

8.2.3.2 Correction when MODE = 1

The correction is triggered once every four minutes and then correction pulses are applied once per second up to a maximum of 60 pulses. When correction values greater than 60 pulses are used, additional correction pulses are made in the 59<sup>th</sup> second.

Clock correction is made more frequently in MODE = 1; however, this can result in higher power consumption.

Table 16. Correction pulses for MODE = 1

Correction value	Update every n <sup>th</sup> minute	Second	Correction pulses on INT per second <sup>[1]</sup>
+1 or -1	2	00	1
+2 or -2	2	00 and 01	1
+3 or -3	2	00, 01, and 02	1
:	:	:	:
+59 or -59	2	00 to 58	1
+60 or -60	2	00 to 59	1
+61 or -61	2	00 to 58	1
	2	59	2
+62 or -62	2	00 to 58	1
	2	59	3
+63 or -63	2	00 to 58	1
	2	59	4
-64	2	00 to 58	1
	2	59	5

[1] The correction pulses on pin INT are 1/1024 s wide. For multiple pulses, they are repeated at an interval of 1/512 s.

In MODE = 1, any timer source clock using a frequency below 1.024 kHz is also affected by the clock correction (see Table 17).

Table 17. Effect of correction pulses on frequencies for MODE = 1

Frequency (Hz)	Effect of correction
<b>CLKOUT</b>	
32768	no effect
16384	no effect
8192	no effect
4096	no effect
2048	no effect
1024	no effect
1	affected
<b>Timer source clock</b>	
4096	no effect
64	affected
1	affected
1/60	affected

8.2.3.3 Offset calibration workflow

The calibration offset has to be calculated based on the time. [Figure 9](#) shows the workflow how the offset register values can be calculated:

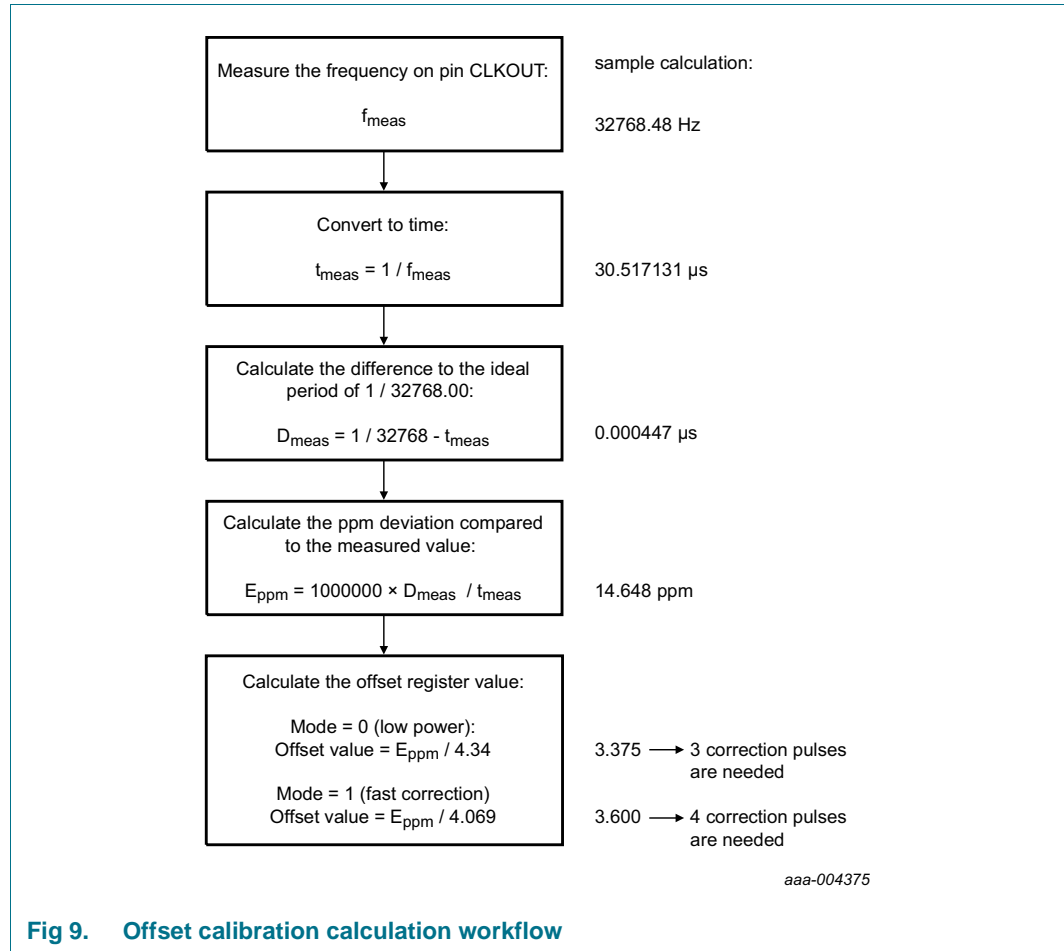
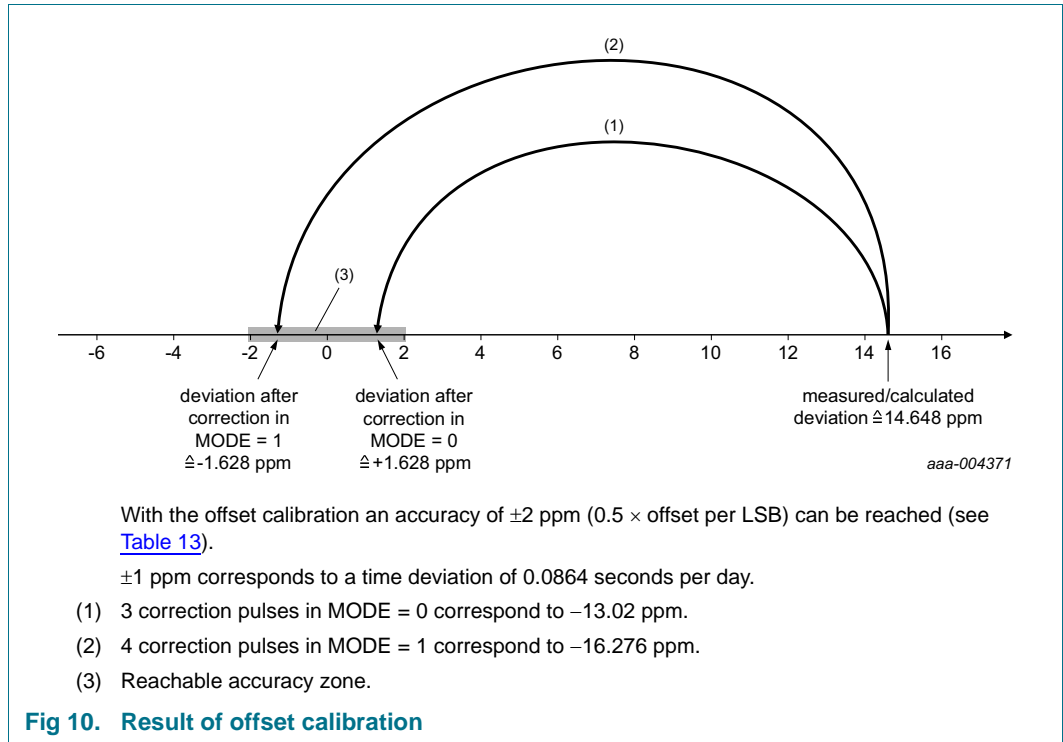

Fig 9. Offset calibration calculation workflow



### 8.2.4 Register RAM\_byte

The PCA85063A provides a free RAM byte, which can be used for any purpose, for example, status byte of the system.

**Table 18. RAM\_byte - 8-bit RAM register (address 03h) bit description**

Bit	Symbol	Value	Description
7 to 0	B[7:0]	00000000 <sup>[1]</sup> to 11111111	RAM content

[1] Default value.

## 8.3 Time and date registers

Most of the registers are coded in the BCD format to simplify application use.

### 8.3.1 Register Seconds

**Table 19. Seconds - seconds register (address 04h) bit description**

Bit	Symbol	Value	Place value	Description
7	OS			<b>oscillator stop</b>
		0	-	clock integrity is guaranteed
		1 <sup>[1]</sup>	-	clock integrity is not guaranteed; oscillator has stopped or has been interrupted
6 to 4	SECONDS	0 <sup>[1]</sup> to 5	ten's place	<b>actual seconds</b> coded in BCD format, see <a href="#">Table 20</a>
3 to 0		0 <sup>[1]</sup> to 9	unit place	

[1] Default value.

Table 20. Seconds coded in BCD format

Seconds value in decimal	Upper-digit (ten's place)			Digit (unit place)			
	Bit 6	Bit 5	Bit 4	Bit 3	Bit 2	Bit 1	Bit 0
00 <sup>[1]</sup>	0	0	0	0	0	0	0
01	0	0	0	0	0	0	1
02	0	0	0	0	0	1	0
:	:	:	:	:	:	:	:
09	0	0	0	1	0	0	1
10	0	0	1	0	0	0	0
:	:	:	:	:	:	:	:
58	1	0	1	1	0	0	0
59	1	0	1	1	0	0	1

[1] Default value.

### 8.3.1.1 OS: Oscillator stop

When the oscillator of the PCA85063A is stopped, the OS flag is set. The oscillator can be stopped, for example, by connecting one of the oscillator pins OSC1 or OSC0 to ground. The oscillator is considered to be stopped during the time between power-on and stable crystal resonance. This time can be in the range of 200 ms to 2 s depending on crystal type, temperature, and supply voltage.

The flag remains set until cleared by command (see [Figure 11](#)). If the flag cannot be cleared, then the oscillator is not running. This method can be used to monitor the oscillator and to determine if the supply voltage has reduced to the point where oscillation fails.

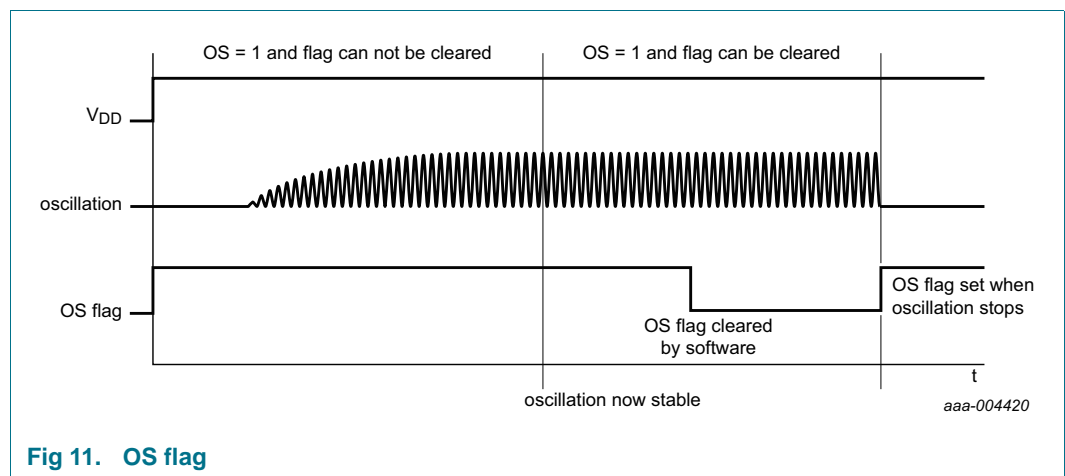

Fig 11. OS flag

### 8.3.2 Register Minutes

Table 21. Minutes - minutes register (address 05h) bit description

Bit	Symbol	Value	Place value	Description
7	-	0	-	unused
6 to 4	MINUTES	0 <sup>[1]</sup> to 5	ten's place	<b>actual minutes</b> coded in BCD format
3 to 0		0 <sup>[1]</sup> to 9	unit place	

[1] Default value.

### 8.3.3 Register Hours

Table 22. Hours - hours register (address 06h) bit description

Bit	Symbol	Value	Place value	Description
7 to 6	-	00	-	unused
<b>12-hour mode<sup>[1]</sup></b>				
5	AMPM			<b>AM/PM indicator</b>
		0 <sup>[2]</sup>	-	AM
		1	-	PM
4	HOURS	0 <sup>[2]</sup> to 1	ten's place	<b>actual hours in 12-hour mode</b> coded in BCD format
3 to 0		0 <sup>[2]</sup> to 9	unit place	
<b>24-hour mode<sup>[1]</sup></b>				
5 to 4	HOURS	0 <sup>[2]</sup> to 2	ten's place	<b>actual hours in 24-hour mode</b> coded in BCD format
3 to 0		0 <sup>[2]</sup> to 9	unit place	

[1] Hour mode is set by the 12\_24 bit in register Control\_1.

[2] Default value.

### 8.3.4 Register Days

Table 23. Days - days register (address 07h) bit description

Bit	Symbol	Value	Place value	Description
7 to 6	-	00	-	unused
5 to 4	DAYS <sup>[1]</sup>	0 <sup>[2]</sup> to 3	ten's place	<b>actual day</b> coded in BCD format
3 to 0		0 <sup>[3]</sup> to 9	unit place	

[1] If the year counter contains a value, which is exactly divisible by 4 (including the year 00), the PCA85063A compensates for leap years by adding a 29th day to February.

[2] Default value.

[3] Default value is 1.

### 8.3.5 Register Weekdays

Table 24. Weekdays - weekdays register (address 08h) bit description

Bit	Symbol	Value	Description
7 to 3	-	00000	unused
2 to 0	WEEKDAYS	0 to 6	<b>actual weekday</b> values, see <a href="#">Table 25</a>

Table 25. Weekday assignments

Day <sup>[1]</sup>	Bit		
	2	1	0
Sunday	0	0	0
Monday	0	0	1
Tuesday	0	1	0
Wednesday	0	1	1
Thursday	1	0	0
Friday	1	0	1
Saturday <sup>[2]</sup>	1	1	0

[1] Definition may be reassigned by the user.

[2] Default value.

### 8.3.6 Register Months

Table 26. Months - months register (address 09h) bit description

Bit	Symbol	Value	Place value	Description
7 to 5	-	000	-	unused
4	MONTHS	0 to 1	ten's place	<b>actual month</b> coded in BCD format, see <a href="#">Table 27</a>
3 to 0		0 to 9	unit place	

Table 27. Month assignments in BCD format

Month	Upper-digit (ten's place)	Digit (unit place)			
	Bit 4	Bit 3	Bit 2	Bit 1	Bit 0
January <sup>[1]</sup>	0	0	0	0	1
February	0	0	0	1	0
March	0	0	0	1	1
April	0	0	1	0	0
May	0	0	1	0	1
June	0	0	1	1	0
July	0	0	1	1	1
August	0	1	0	0	0
September	0	1	0	0	1
October	1	0	0	0	0
November	1	0	0	0	1
December	1	0	0	1	0

[1] Default value.

### 8.3.7 Register Years

Table 28. Years - years register (0Ah) bit description

Bit	Symbol	Value	Place value	Description
7 to 4	YEARS	0[1] to 9	ten's place	actual year coded in BCD format
3 to 0		0[1] to 9	unit place	

[1] Default value.

### 8.4 Setting and reading the time

Figure 12 shows the data flow and data dependencies starting from the 1 Hz clock tick.

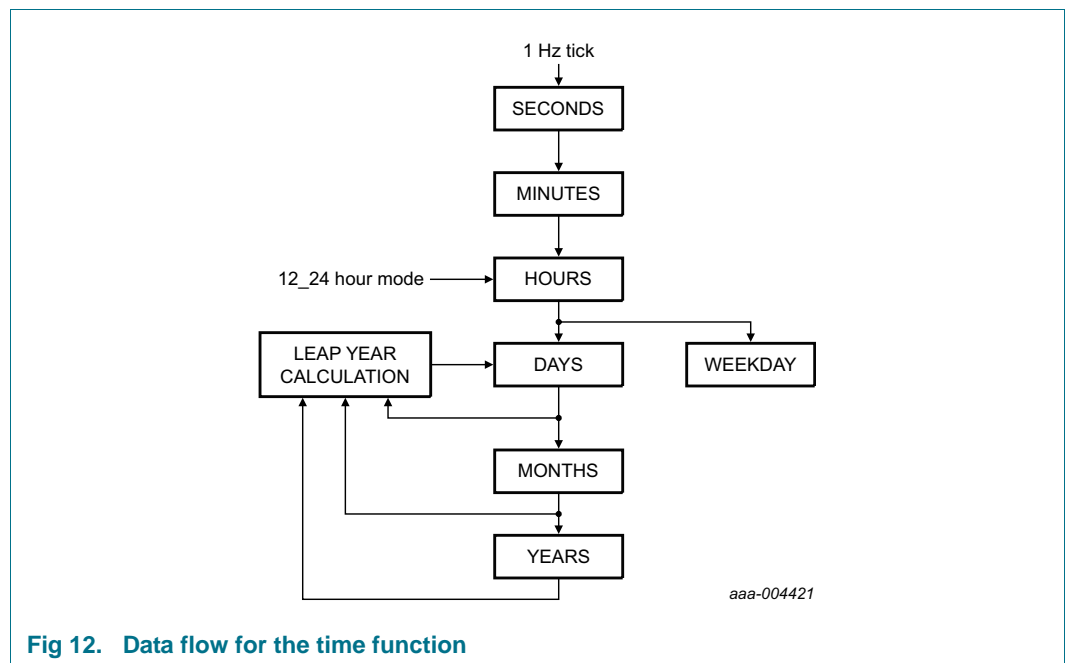

Fig 12. Data flow for the time function

During read/write operations, the time counting circuits (memory locations 04h through 0Ah) are blocked.

The blocking prevents

- Faulty reading of the clock and calendar during a carry condition
- Incrementing the time registers during the read cycle

After this read/write access is completed, the time circuit is released again and any pending request to increment the time counters that occurred during the read/write access is serviced. A maximum of 1 request can be stored; therefore, all accesses must be completed within 1 second (see Figure 13).

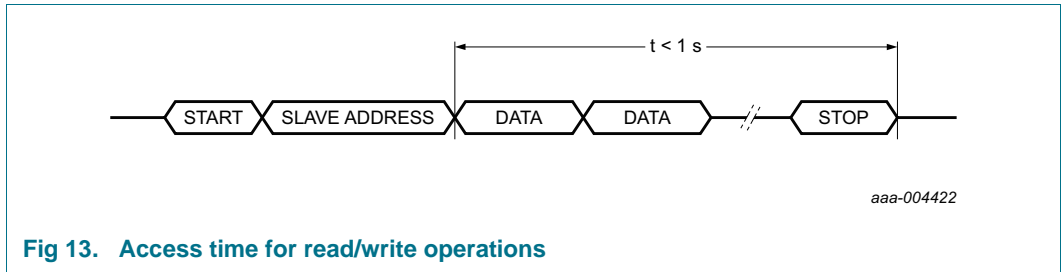

Because of this method, it is very important to make a read or write access in one go, that is, setting or reading seconds through to years should be made in one single access. Failing to comply with this method could result in the time becoming corrupted.

As an example, if the time (seconds through to hours) is set in one access and then in a second access the date is set, it is possible that the time will increment between the two accesses. A similar problem exists when reading. A roll-over may occur between reads thus giving the minutes from one moment and the hours from the next.

Recommended method for reading the time:

1. Send a START condition and the slave address (see [Table 39 on page 33](#)) for write (A2h)
2. Set the address pointer to 4 (Seconds) by sending 04h
3. Send a RESTART condition or STOP followed by START
4. Send the slave address for read (A3h)
5. Read Seconds
6. Read Minutes
7. Read Hours
8. Read Days
9. Read Weekdays
10. Read Months
11. Read Years
12. Send a STOP condition

## 8.5 Alarm registers

### 8.5.1 Register Second\_alarm

Table 29. Second\_alarm - second alarm register (address 0Bh) bit description

Bit	Symbol	Value	Place value	Description
7	AEN_S			<b>second alarm</b>
		0	-	enabled
		1 <sup>[1]</sup>	-	disabled
6 to 4	SECOND_ALARM	0 <sup>[1]</sup> to 5	ten's place	<b>second alarm information</b> coded in BCD format
3 to 0		0 <sup>[1]</sup> to 9	unit place	

[1] Default value.

### 8.5.2 Register Minute\_alarm

Table 30. Minute\_alarm - minute alarm register (address 0Ch) bit description

Bit	Symbol	Value	Place value	Description
7	AEN_M			<b>minute alarm</b>
		0	-	enabled
		1 <sup>[1]</sup>	-	disabled
6 to 4	MINUTE_ALARM	0 <sup>[1]</sup> to 5	ten's place	<b>minute alarm information</b> coded in BCD format
3 to 0		0 <sup>[1]</sup> to 9	unit place	

[1] Default value.

### 8.5.3 Register Hour\_alarm

Table 31. Hour\_alarm - hour alarm register (address 0Dh) bit description

Bit	Symbol	Value	Place value	Description
7	AEN_H			<b>hour alarm</b>
		0	-	enabled
		1 <sup>[1]</sup>	-	disabled
6	-	0	-	unused
<b>12-hour mode<sup>[2]</sup></b>				
5	AMPM			<b>AM/PM indicator</b>
		0 <sup>[1]</sup>	-	AM
		1	-	PM
4	HOUR_ALARM	0 <sup>[1]</sup> to 1	ten's place	<b>hour alarm information in 12-hour mode</b> coded in BCD format
3 to 0		0 <sup>[1]</sup> to 9	unit place	
<b>24-hour mode<sup>[2]</sup></b>				
5 to 4	HOUR_ALARM	0 <sup>[1]</sup> to 2	ten's place	<b>hour alarm information in 24-hour mode</b> coded in BCD format
3 to 0		0 <sup>[1]</sup> to 9	unit place	

[1] Default value.

[2] Hour mode is set by the 12\_24 bit in register Control\_1.

### 8.5.4 Register Day\_alarm

Table 32. Day\_alarm - day alarm register (address 0Eh) bit description

Bit	Symbol	Value	Place value	Description
7	AEN_D			<b>day alarm</b>
		0	-	enabled
		1 <sup>[1]</sup>	-	disabled
6	-	0	-	unused
5 to 4	DAY_ALARM	0 <sup>[1]</sup> to 3	ten's place	<b>day alarm information</b> coded in BCD format
3 to 0		0 <sup>[1]</sup> to 9	unit place	

[1] Default value.

### 8.5.5 Register Weekday\_alarm

Table 33. Weekday\_alarm - weekday alarm register (address 0Fh) bit description

Bit	Symbol	Value	Description
7	AEN_W		<b>weekday alarm</b>
		0	enabled
		1 <sup>[1]</sup>	disabled
6 to 3	-	0	unused
2 to 0	WEEKDAY_ALARM	0 <sup>[1]</sup> to 6	<b>weekday alarm information</b> coded in BCD format

[1] Default value.

### 8.5.6 Alarm function

By clearing the alarm enable bit (AEN\_x) of one or more of the alarm registers, the corresponding alarm condition(s) are active. When an alarm occurs, AF is set logic 1. The asserted AF can be used to generate an interrupt ( $\overline{\text{INT}}$ ). The AF is cleared by command.

The registers at addresses 0Bh through 0Fh contain alarm information. When one or more of these registers is loaded with second, minute, hour, day or weekday, and its corresponding AEN\_x is logic 0, then that information is compared with the current second, minute, hour, day, and weekday. When all enabled comparisons first match, the alarm flag (AF in register Control\_2) is set logic 1.

The generation of interrupts from the alarm function is controlled via bit AIE. If bit AIE is enabled, the  $\overline{\text{INT}}$  pin follows the condition of bit AF. AF remains set until cleared by command. Once AF has been cleared, it will only be set again when the time increments to match the alarm condition once more. Alarm registers which have their AEN\_x bit at logic 1 are ignored.

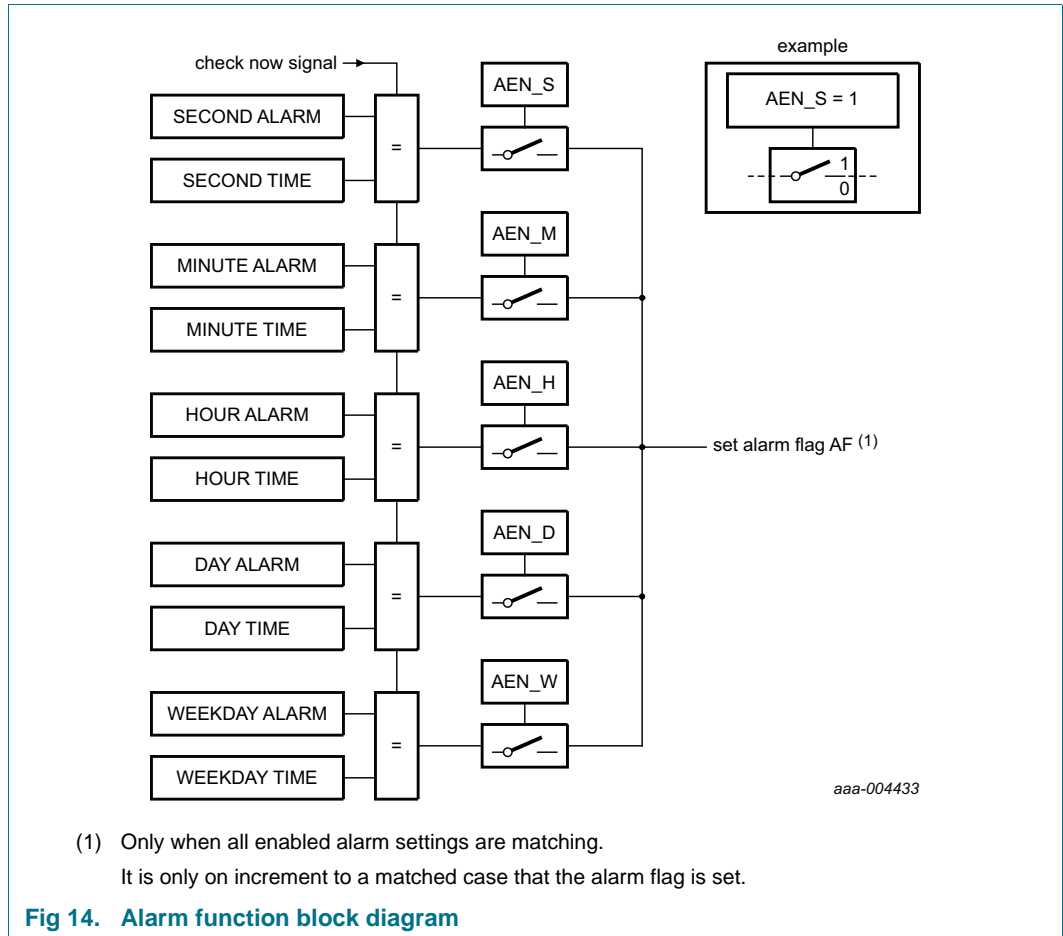

## 8.6 Timer registers

The 8-bit countdown timer at address 10h is controlled by the register Timer\_mode at address 11h.

### 8.6.1 Register Timer\_value

**Table 34. Timer\_value - timer value register (address 10h) bit description**

Bit	Symbol	Value	Description
7 to 0	T[7:0]	0h <sup>[1]</sup> to FFh	countdown timer value <sup>[2]</sup>

[1] Default value.

[2] Countdown period in seconds:  $CountdownPeriod = \frac{T}{SourceClockFrequency}$  where T is the countdown value.

## 8.6.2 Register Timer\_mode

Table 35. Timer\_mode - timer control register (address 11h) bit description

Bit	Symbol	Value	Description
7 to 5	-	000	unused
4 to 3	TCF[1:0]		<b>timer clock frequency</b>
		00	4.096 kHz timer source clock
		01	64 Hz timer source clock
		10	1 Hz timer source clock
		11 <sup>[1]</sup>	$\frac{1}{60}$ Hz timer source clock
2	TE		<b>timer enable</b>
		0 <sup>[1]</sup>	timer is disabled
		1	timer is enabled
1	TIE		<b>timer interrupt enable</b>
		0 <sup>[1]</sup>	no interrupt generated from timer
		1	interrupt generated from timer
0	TI_TP <sup>[2]</sup>		<b>timer interrupt mode</b>
		0 <sup>[1]</sup>	interrupt follows timer flag
		1	interrupt generates a pulse

[1] Default value.

[2] How the setting of TI\_TP and the timer flag TF can affect the  $\overline{\text{INT}}$  pulse generation is explained in [Section 8.2.2.3 on page 13](#).

## 8.6.3 Timer functions

The timer has four selectable source clocks allowing for countdown periods in the range from 244  $\mu\text{s}$  to 4 hours 15 min. For periods longer than 4 hours, the alarm function can be used.

Table 36. Timer clock frequency and timer durations

TCF[1:0]	Timer source clock frequency <sup>[1]</sup>	Delay	
		Minimum timer duration T = 1	Maximum timer duration T = 255
00	4.096 kHz	244 $\mu\text{s}$	62.256 ms
01	64 Hz	15.625 ms	3.984 s
10	1 Hz <sup>[2]</sup>	1 s	255 s
11	$\frac{1}{60}$ Hz <sup>[2]</sup>	60 s	4 hours 15 min

[1] When not in use, TCF[1:0] must be set to  $\frac{1}{60}$  Hz for power saving.

[2] Time periods can be affected by correction pulses.

**Remark:** Note that all timings which are generated from the 32.768 kHz oscillator are based on the assumption that there is 0 ppm deviation. Deviation in oscillator frequency results in deviation in timings. This is not applicable to interface timing.

The timer counts down from a software-loaded 8-bit binary value, T[7:0], in register Timer\_value. Loading the counter with 0 stops the timer. Values from 1 to 255 are valid.

When the counter decrements from 1, the timer flag (bit TF in register Control\_2) is set and the counter automatically re-loads and starts the next timer period.

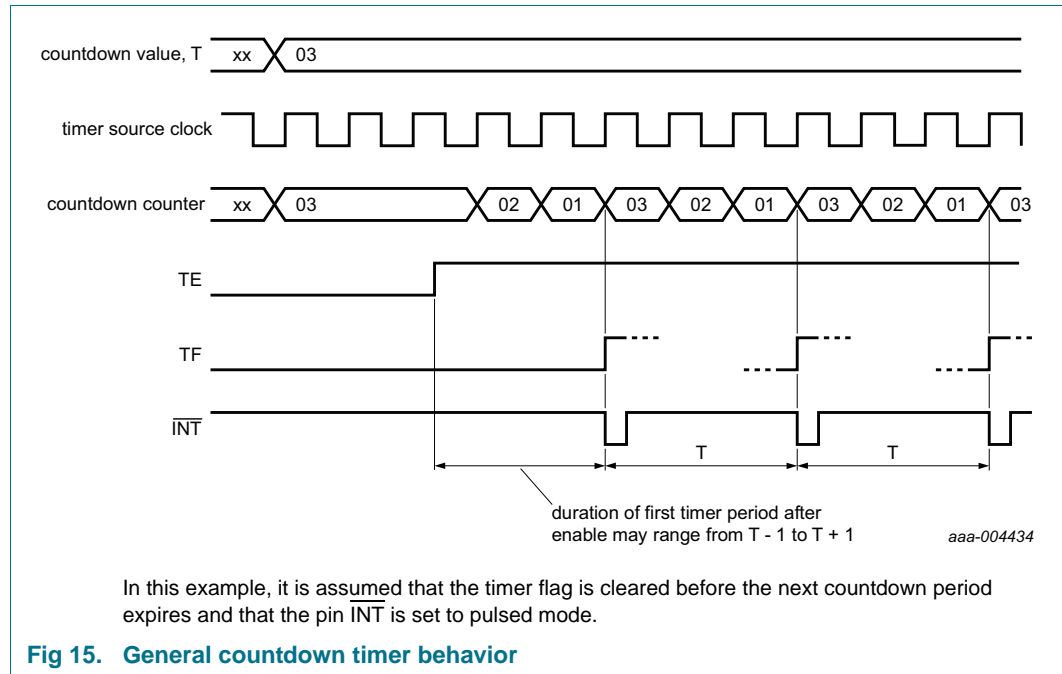

If a new value of T is written before the end of the current timer period, then this value takes immediate effect. NXP does not recommend changing T without first disabling the counter by setting bit TE logic 0. The update of T is asynchronous to the timer clock. Therefore changing it without setting bit TE logic 0 may result in a corrupted value loaded into the countdown counter. This results in an undetermined countdown period for the first period. The countdown value T will, however, be correctly stored and correctly loaded on subsequent timer periods.

When the TIE flag is set, an interrupt signal on INT is generated if this mode is enabled. See [Section 8.2.2](#) for details on how the interrupt can be controlled.

When starting the timer for the first time, the first period has an uncertainty. The uncertainty is a result of the enable instruction being generated from the interface clock which is asynchronous from the timer source clock. Subsequent timer periods do not have such delay. The amount of delay for the first timer period depends on the chosen source clock, see [Table 37](#).

**Table 37. First period delay for timer counter value T**

Timer source clock	Minimum timer period	Maximum timer period
4.096 kHz	T	T + 1
64 Hz	T	T + 1
1 Hz	$(T - 1) + \frac{1}{64 \text{ Hz}}$	$T + \frac{1}{64 \text{ Hz}}$
1/60 Hz	$(T - 1) + \frac{1}{64 \text{ Hz}}$	$T + \frac{1}{64 \text{ Hz}}$

At the end of every countdown, the timer sets the countdown timer flag (bit TF in register Control\_2). Bit TF can only be cleared by command. The asserted bit TF can be used to generate an interrupt at pin INT. The interrupt may be generated as a pulsed signal every countdown period or as a permanently active signal which follows the condition of bit TF. Bit TI\_TP is used to control this mode selection and the interrupt output may be disabled with bit TIE, see Table 35 and Figure 15.

When reading the timer, the current countdown value is returned and **not** the initial value T. Since it is not possible to freeze the countdown timer counter during read back, it is recommended to read the register twice and check for consistent results.

Timer source clock frequency selection of 1 Hz and 1/60 Hz is affected by the Offset register. The duration of a program period varies according to when the offset is initiated. For example, if a 100 s timer is set using the 1 Hz clock as source, then some 100 s periods will contain correction pulses and therefore be longer or shorter depending on the setting of the Offset register. See Section 8.2.3 to understand the operation of the Offset register.

### 8.6.3.1 Countdown timer interrupts

The pulse generator for the countdown timer interrupt uses an internal clock and is dependent on the selected source clock for the countdown timer and on the countdown value T. As a consequence, the width of the interrupt pulse varies (see Table 38).

**Table 38.** INT operation

TF and INT become active simultaneously.

Source clock (Hz)	INT period (s)	
	T = 1 <sup>[1]</sup>	T > 1 <sup>[1]</sup>
4096	1/8192	1/4096
64	1/128	1/64
1	1/64	1/64
1/60	1/64	1/64

[1] T = loaded countdown value. Timer stops when T = 0.

## 9. Characteristics of the I<sup>2</sup>C-bus interface

The I<sup>2</sup>C-bus is for bidirectional, two-line communication between different ICs or modules. The two lines are a Serial DATA line (SDA) and a Serial CLOCK line (SCL). Both lines must be connected to a positive supply via a pull-up resistor. Data transfer may be initiated only when the bus is not busy.

### 9.1 Bit transfer

One data bit is transferred during each clock pulse. The data on the SDA line must remain stable during the HIGH period of the clock pulse, as changes in the data line at this time are interpreted as a control signal (see [Figure 16](#)).

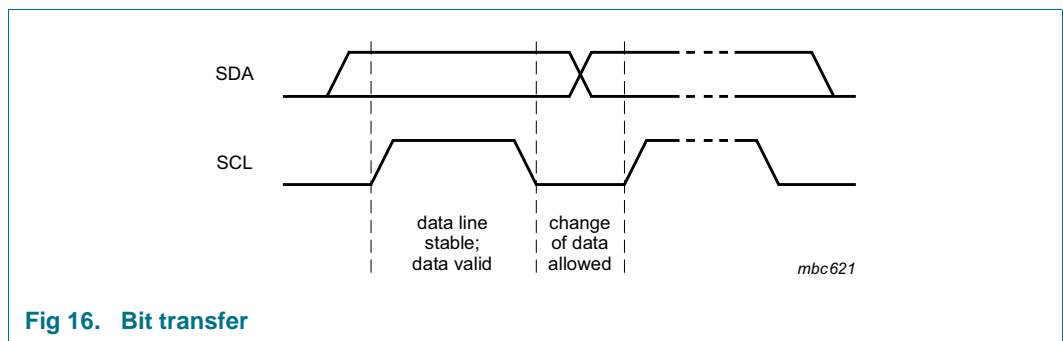

Fig 16. Bit transfer

### 9.2 START and STOP conditions

Both data and clock lines remain HIGH when the bus is not busy.

A HIGH-to-LOW transition of the data line while the clock is HIGH is defined as the START condition - S.

A LOW-to-HIGH transition of the data line while the clock is HIGH is defined as the STOP condition - P (see [Figure 17](#)).

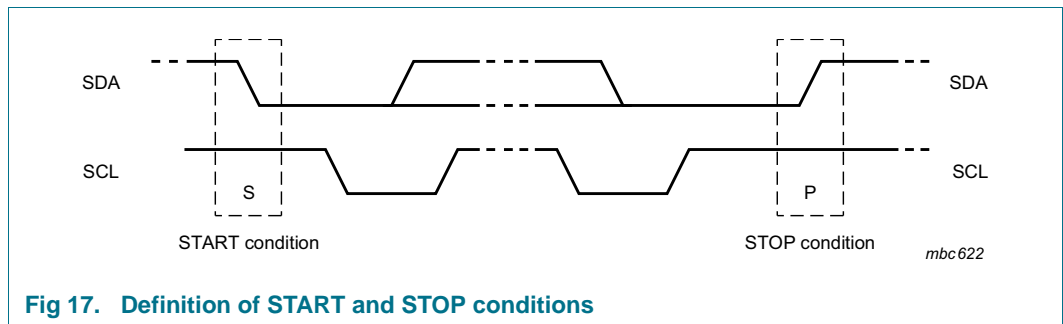

Fig 17. Definition of START and STOP conditions

### 9.3 System configuration

A device generating a message is a transmitter; a device receiving a message is a receiver. The device that controls the message is the master; and the devices which are controlled by the master are the slaves (see [Figure 18](#)).

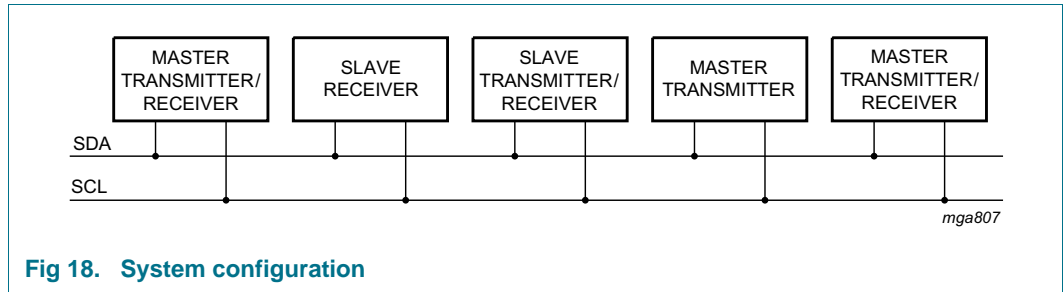

Fig 18. System configuration

### 9.4 Acknowledge

The number of data bytes transferred between the START and STOP conditions from transmitter to receiver is unlimited. Each byte of 8 bits is followed by an acknowledge cycle.

- A slave receiver, which is addressed, must generate an acknowledge after the reception of each byte
- Also a master receiver must generate an acknowledge after the reception of each byte that has been clocked out of the slave transmitter
- The device that acknowledges must pull-down the SDA line during the acknowledge clock pulse, so that the SDA line is stable LOW during the HIGH period of the acknowledge related clock pulse (set-up and hold times must be considered)
- A master receiver must signal an end of data to the transmitter by not generating an acknowledge on the last byte that has been clocked out of the slave. In this event, the transmitter must leave the data line HIGH to enable the master to generate a STOP condition

Acknowledgement on the I<sup>2</sup>C-bus is shown in [Figure 19](#).

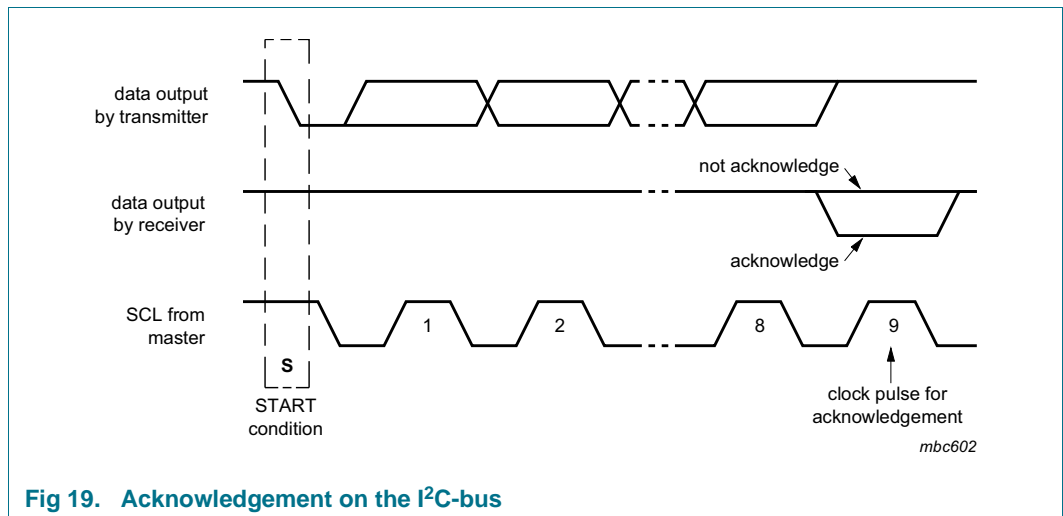

Fig 19. Acknowledgement on the I<sup>2</sup>C-bus

## 9.5 I<sup>2</sup>C-bus protocol

### 9.5.1 Addressing

One I<sup>2</sup>C-bus slave address (1010001) is reserved for the PCA85063A. The entire I<sup>2</sup>C-bus slave address byte is shown in [Table 39](#).

**Table 39. I<sup>2</sup>C slave address byte**

Bit	Slave address							0
	7	6	5	4	3	2	1	
	1	0	1	0	0	0	1	R/ $\overline{W}$

After a START condition, the I<sup>2</sup>C slave address has to be sent to the PCA85063A device.

The  $\overline{R/W}$  bit defines the direction of the following single or multiple byte data transfer ( $\overline{R/W} = 0$  for writing,  $\overline{R/W} = 1$  for reading). For the format and the timing of the START condition (S), the STOP condition (P) and the acknowledge bit (A) refer to the I<sup>2</sup>C-bus characteristics (see [Ref. 12 "UM10204"](#)). In the write mode, a data transfer is terminated by sending either the STOP condition or the START condition of the next data transfer.

### 9.5.2 Clock and calendar READ or WRITE cycles

The I<sup>2</sup>C-bus configuration for the different PCA85063A READ and WRITE cycles is shown in [Figure 20](#) and [Figure 21](#). The register address is a 5-bit value that defines which register is to be accessed next. The upper 3 bits of the register address are not used.

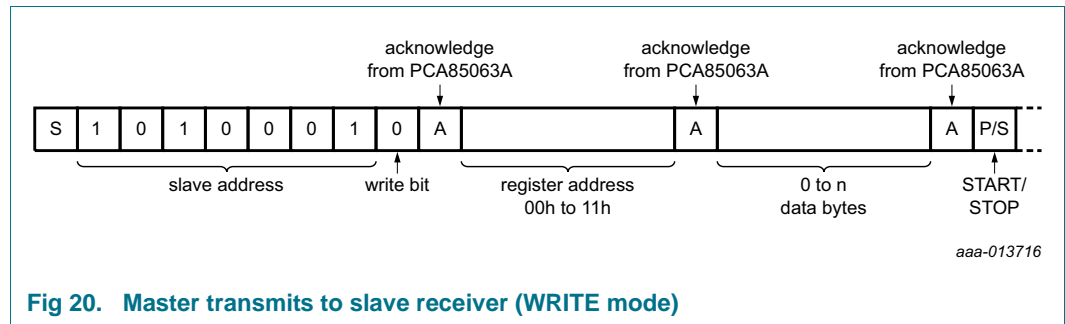

**Fig 20. Master transmits to slave receiver (WRITE mode)**

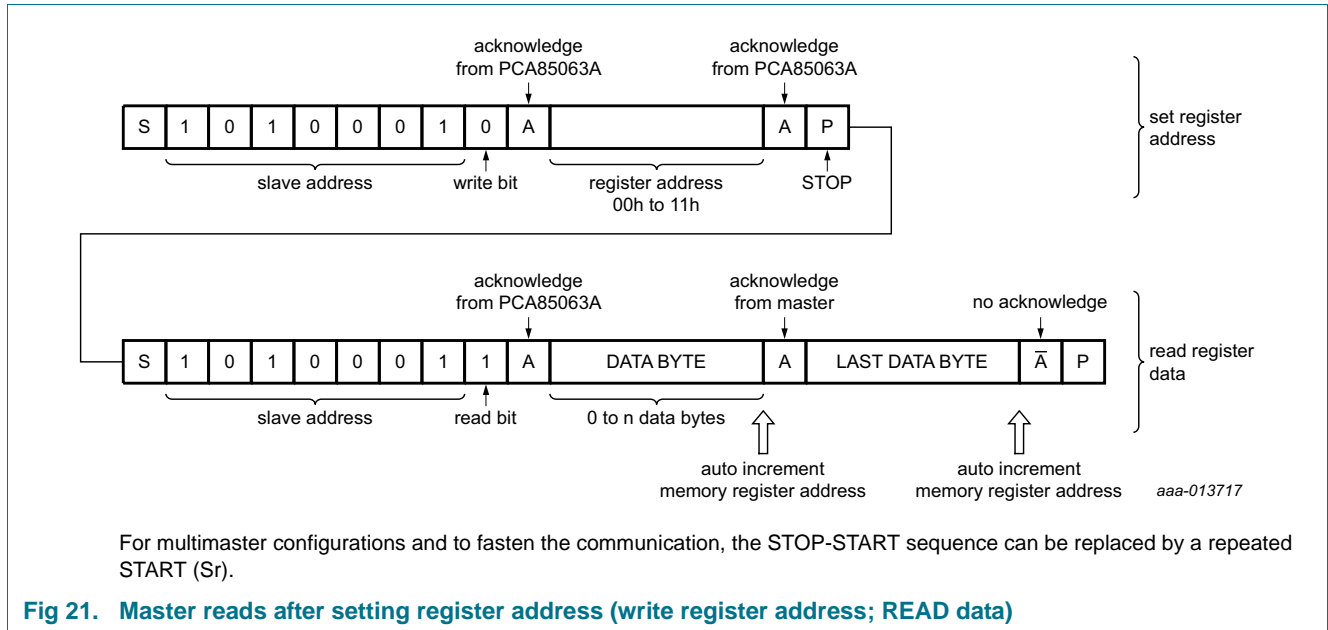

**Fig 21. Master reads after setting register address (write register address; READ data)**

### 9.5.3 I<sup>2</sup>C-bus error recovery technique

Slave devices like the PCA85063A use a state machine to implement the I<sup>2</sup>C protocol and expect a certain sequence of events to occur to function properly. Unexpected events at the I<sup>2</sup>C master can wreak havoc with the slaves connected on the bus. However, it is usually possible to recover deterministically to a known bus state with careful protocol manipulation.

A deterministic method to clear this situation if SDA is stuck LOW (it effectively blocks any other I<sup>2</sup>C-bus transaction, once the master recognizes a 'stuck bus' state), is for the master to blindly transmit nine clocks on SCL. If the slave was transmitting data or acknowledging, nine or more clocks ensures the slave state machine returns to a known, idle state since the protocol calls for eight data bits and one ACK bit. It does not matter when the slave state machine finishes its transmission; extra clocks are recognized as STOP conditions.

With careful design of the bus master error recovery firmware, many I<sup>2</sup>C-bus protocol problems can be avoided.

S/W considerations: NXP recommends customers allow for S/W reset capability to enable the bus error recovery technique. The 9-clock pulse method as described above involves a bus-master capable of providing such a signal.

Further comments/additional information are available in [Ref. 13 "UM10301"](#) and [Ref. 12 "UM10204"](#).

## 10. Internal circuitry

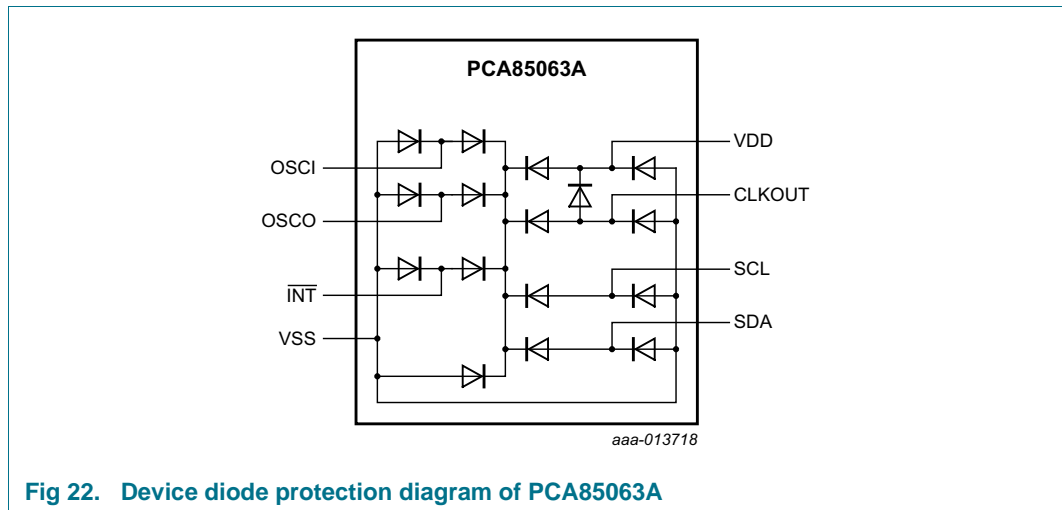

## 11. Safety notes

### CAUTION



This device is sensitive to ElectroStatic Discharge (ESD). Observe precautions for handling electrostatic sensitive devices.

Such precautions are described in the *ANSI/ESD S20.20*, *IEC/ST 61340-5*, *JESD625-A* or equivalent standards.

## 12. Limiting values

**Table 40. Limiting values<sup>[1]</sup>**

In accordance with the Absolute Maximum Rating System (IEC 60134).

Symbol	Parameter	Conditions	Min	Max	Unit
V <sub>DD</sub>	supply voltage		-0.5	+6.5	V
I <sub>DD</sub>	supply current		-50	+50	mA
V <sub>I</sub>	input voltage	on pins SCL, SDA, OSCI	-0.5	+6.5	V
V <sub>O</sub>	output voltage		-0.5	+6.5	V
I <sub>I</sub>	input current	at any input	-10	+10	mA
I <sub>O</sub>	output current	at any output	-10	+10	mA
P <sub>tot</sub>	total power dissipation		-	300	mW
V <sub>ESD</sub>	electrostatic discharge voltage	HBM <sup>[2]</sup>	-	±5000	V
		CDM <sup>[3]</sup>	-	±2000	V
I <sub>Iu</sub>	latch-up current		<sup>[4]</sup>	200	mA
T <sub>stg</sub>	storage temperature		<sup>[5]</sup> -65	+150	°C
T <sub>amb</sub>	ambient temperature	operating device	-40	+105	°C

- [1] Remark: The PCA85063A part is not guaranteed (nor characterized) above the operating range as denoted in the datasheet. NXP recommends not to bias the PCA85063A device during reflow (e.g. if utilizing a 'coin' type battery in the assembly). If customer so chooses to continue to use this assembly method, there must be the allowance for a full '0 V' level Power supply 'reset' to re-enable the device. Without a proper POR, the device may remain in an indeterminate state.
- [2] Pass level; Human Body Model (HBM) according to [Ref. 7 "JESD22-A114"](#).
- [3] Pass level; Charged-Device Model (CDM), according to [Ref. 8 "JESD22-C101"](#).
- [4] Pass level; latch-up testing, according to [Ref. 9 "JESD78"](#) at maximum ambient temperature (T<sub>amb(max)</sub>).
- [5] According to the store and transport requirements (see [Ref. 14 "UM10569"](#)) the devices have to be stored at a temperature of +8 °C to +45 °C and a humidity of 25 % to 75 %.

### 13. Characteristics

**Table 41. Static characteristics**

$V_{DD} = 0.9\text{ V to }5.5\text{ V}$ ;  $V_{SS} = 0\text{ V}$ ;  $T_{amb} = -40\text{ °C to }+105\text{ °C}$ ;  $f_{osc} = 32.768\text{ kHz}$ ; quartz  $R_s = 60\text{ k}\Omega$ ;  $C_L = 7\text{ pF}$ ; unless otherwise specified.

Symbol	Parameter	Conditions	Min	Typ	Max	Unit
<b>Supplies</b>						
$V_{DD}$	supply voltage	interface inactive; $f_{SCL} = 0\text{ Hz}$ [1]	0.9	-	5.5	V
		interface active; $f_{SCL} = 400\text{ kHz}$ [1]	1.8	-	5.5	V
$I_{DD}$	supply current	CLKOUT disabled; $V_{DD} = 5\text{ V}$ [2]				
		interface inactive; $f_{SCL} = 0\text{ Hz}$				
		$T_{amb} = 25\text{ °C}$	-	250	450	nA
		$T_{amb} = 85\text{ °C}$	-	550	750	nA
		$T_{amb} = 105\text{ °C}$	-	900	1800	nA
		interface active; $f_{SCL} = 400\text{ kHz}$	-	35	50	$\mu\text{A}$
<b>Inputs</b> [3]						
$V_I$	input voltage		$V_{SS}$	-	5.5	V
$V_{IL}$	LOW-level input voltage		$V_{SS}$	-	$0.3V_{DD}$	V
$V_{IH}$	HIGH-level input voltage		$0.7V_{DD}$	-	$V_{DD}$	V
$I_{LI}$	input leakage current	$V_I = V_{SS}$ or $V_{DD}$	-	0	-	$\mu\text{A}$
		post ESD event	-0.15	-	+0.15	$\mu\text{A}$
$C_i$	input capacitance	[4]	-	-	7	pF
<b>Outputs</b>						
$V_{OH}$	HIGH-level output voltage	on pin CLKOUT	$0.8V_{DD}$	-	$V_{DD}$	V
$V_{OL}$	LOW-level output voltage	on pins SDA, $\overline{\text{INT}}$ , CLKOUT	$V_{SS}$	-	$0.2V_{DD}$	V
$I_{OH}$	HIGH-level output current	output source current; $V_{OH} = 4.6\text{ V}$ ; $V_{DD} = 5\text{ V}$ ; on pin CLKOUT	1	3	-	mA
$I_{OL}$	LOW-level output current	output sink current; $V_{OL} = 0.4\text{ V}$ ; $V_{DD} = 5\text{ V}$				
		on pin SDA	3	8.5	-	mA
		on pin $\overline{\text{INT}}$	2	6	-	mA
		on pin CLKOUT	1	3	-	mA

**Table 41. Static characteristics ...continued**

$V_{DD} = 0.9\text{ V to }5.5\text{ V}$ ;  $V_{SS} = 0\text{ V}$ ;  $T_{amb} = -40\text{ °C to }+105\text{ °C}$ ;  $f_{osc} = 32.768\text{ kHz}$ ; quartz  $R_s = 60\text{ k}\Omega$ ;  $C_L = 7\text{ pF}$ ; unless otherwise specified.

Symbol	Parameter	Conditions	Min	Typ	Max	Unit
<b>Oscillator</b>						
$\Delta f_{osc}/f_{osc}$	relative oscillator frequency variation	$\Delta V_{DD} = 200\text{ mV}$ ; $T_{amb} = 25\text{ °C}$	-	0.075	-	ppm
$C_{L(itg)}$	integrated load capacitance	on pins OSC0, OSC1 [5]				
		$C_L = 7\text{ pF}$	4.2	7	9.8	pF
		$C_L = 12.5\text{ pF}$	7.5	12.5	17.5	pF
$R_s$	series resistance		-	-	100	k $\Omega$

- [1] For reliable oscillator start-up at power-on use  $V_{DD}$  greater than 1.2 V. If powered up at 0.9 V the oscillator will start but it might be a bit slow, especially if at high temperature. Normally the power supply is not 0.9 V at start-up and only comes at the end of battery discharge.  $V_{DD}$  min of 0.9 V is specified so that the customer can calculate how large a battery or capacitor they need for their application.  $V_{DD}$  min of 1.2 V or greater is needed to ensure speedy oscillator start-up time. For a restart condition, NXP recommends a full '0 V'  $V_{DD}$  value upon re-biasing.
- [2] Timer source clock =  $1/60$  Hz, level of pins SCL and SDA is  $V_{DD}$  or  $V_{SS}$ .
- [3] The I<sup>2</sup>C-bus interface of PCA85063A is 5 V tolerant.
- [4] Implicit by design.
- [5] Integrated load capacitance,  $C_{L(itg)}$ , is a calculation of  $C_{OSCI}$  and  $C_{OSCO}$  in series:  $C_{L(itg)} = \frac{(C_{OSCI} \cdot C_{OSCO})}{(C_{OSCI} + C_{OSCO})}$ .

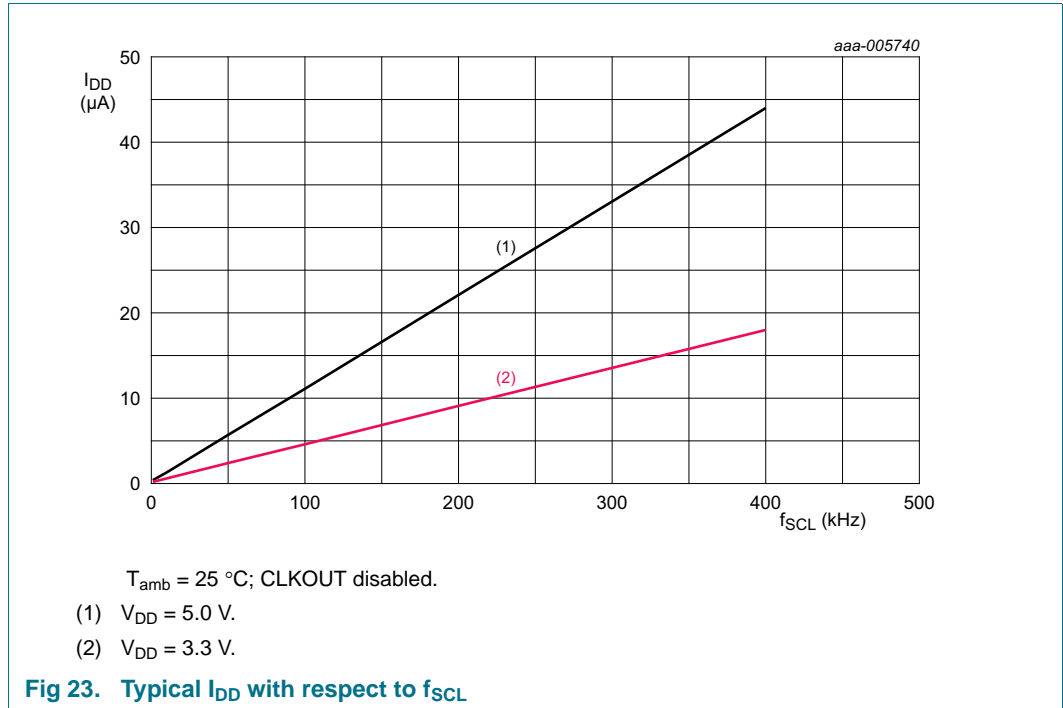

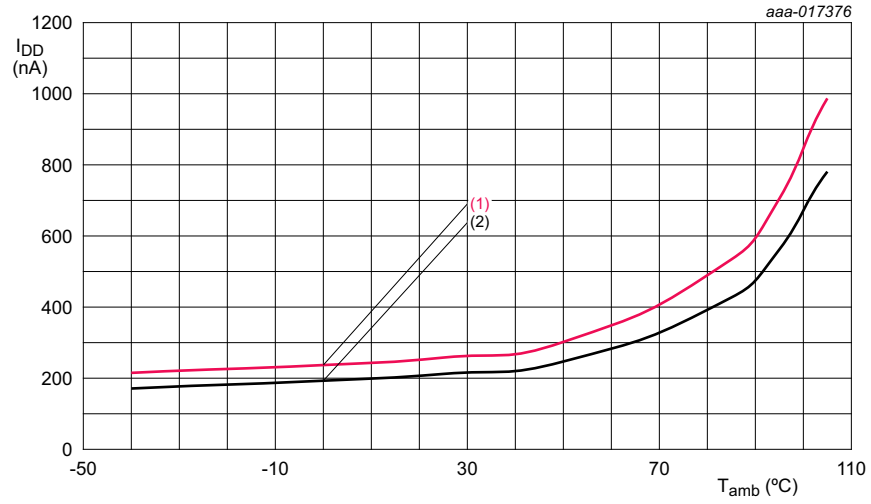

$C_{L(itg)} = 7 \text{ pF}$ ; CLKOUT disabled.

- (1)  $V_{DD} = 5.5 \text{ V}$ .
- (2)  $V_{DD} = 3.3 \text{ V}$ .

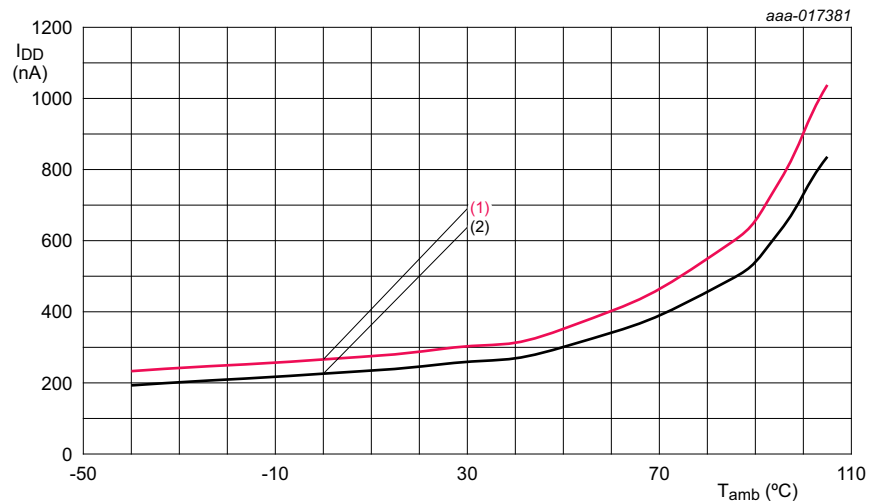

$C_{L(itg)} = 12.5 \text{ pF}$ ; CLKOUT disabled.

- (1)  $V_{DD} = 5.5 \text{ V}$ .
- (2)  $V_{DD} = 3.3 \text{ V}$ .

**Fig 24. Typical  $I_{DD}$  as a function of temperature**

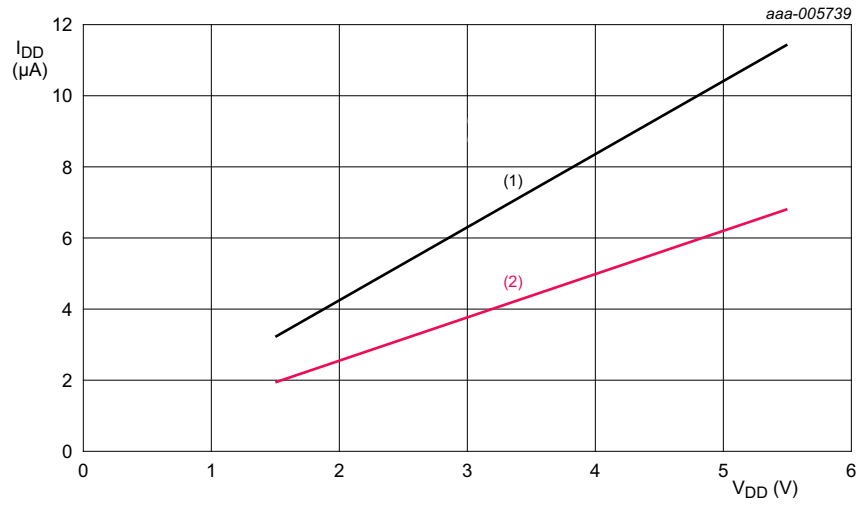

T<sub>amb</sub> = 25 °C; f<sub>CLKOUT</sub> = 32768 Hz.

- (1) 47 pF CLKOUT load.
- (2) 22 pF CLKOUT load.

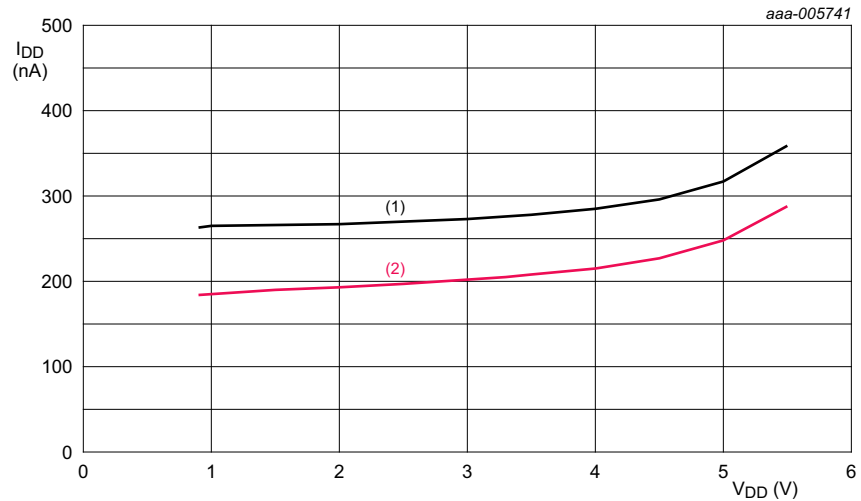

T<sub>amb</sub> = 25 °C; CLKOUT disabled.

- (1) C<sub>L(fitg)</sub> = 12.5 pF.
- (2) C<sub>L(fitg)</sub> = 7 pF.

**Fig 25. Typical I<sub>DD</sub> with respect to V<sub>DD</sub>**

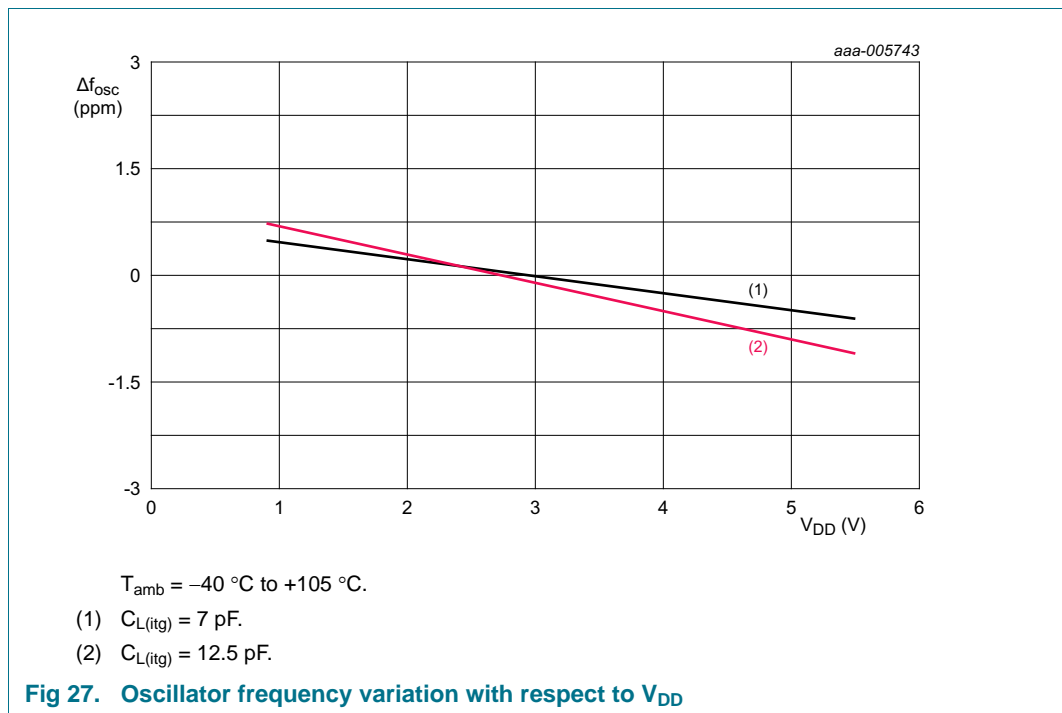
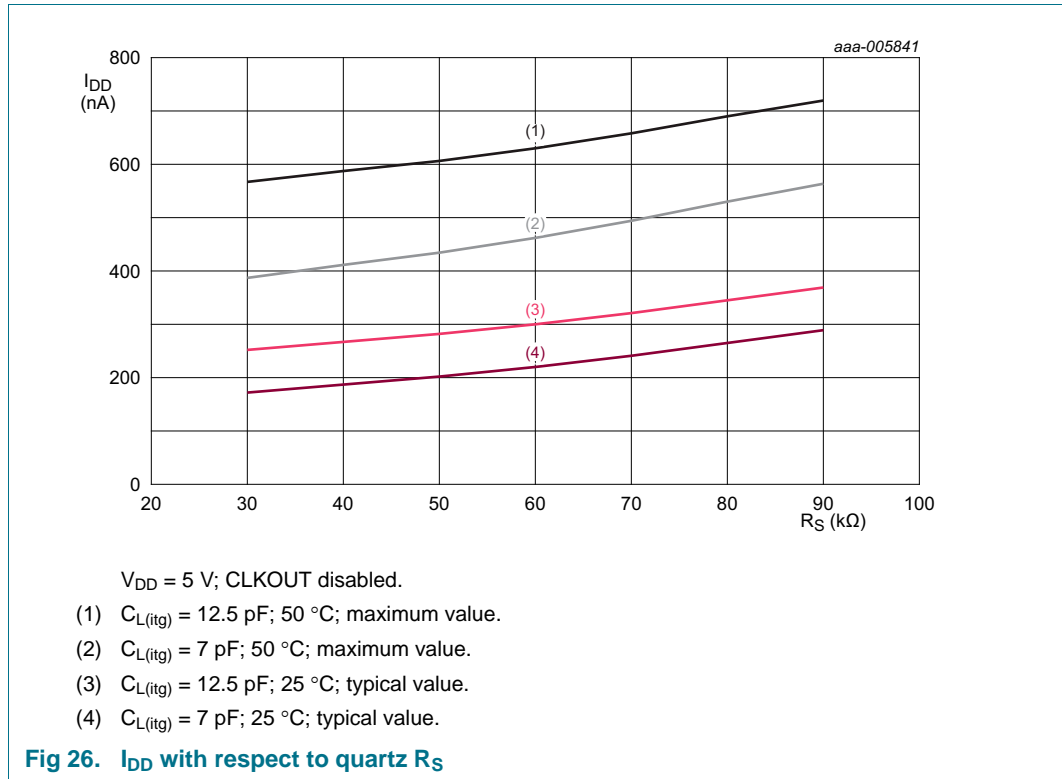

**Table 42. I<sup>2</sup>C-bus characteristics**

$V_{DD} = 1.8\text{ V to }5.5\text{ V}$ ;  $V_{SS} = 0\text{ V}$ ;  $T_{amb} = -40\text{ °C to }+105\text{ °C}$ ;  $f_{osc} = 32.768\text{ kHz}$ ; quartz  $R_s = 60\text{ k}\Omega$ ;  $C_L = 7\text{ pF}$ ; unless otherwise specified. All timing values are valid within the operating supply voltage and temperature range and referenced to  $V_{IL}$  and  $V_{IH}$  with an input voltage swing of  $V_{SS}$  to  $V_{DD}$ <sup>[1]</sup>.

Symbol	Parameter	Conditions	Min	Max	Unit
$C_b$	capacitive load for each bus line		-	400	pF
$f_{SCL}$	SCL clock frequency	[2]	0	400	kHz
$t_{HD;STA}$	hold time (repeated) START condition		0.6	-	$\mu\text{s}$
$t_{SU;STA}$	set-up time for a repeated START condition		0.6	-	$\mu\text{s}$
$t_{LOW}$	LOW period of the SCL clock		1.3	-	$\mu\text{s}$
$t_{HIGH}$	HIGH period of the SCL clock		0.6	-	$\mu\text{s}$
$t_r$	rise time of both SDA and SCL signals		20	300	ns
$t_f$	fall time of both SDA and SCL signals	[3][4]	$20 \times (V_{DD} / 5.5\text{ V})$	300	ns
$t_{BUF}$	bus free time between a STOP and START condition		1.3	-	$\mu\text{s}$
$t_{SU;DAT}$	data set-up time		100	-	ns
$t_{HD;DAT}$	data hold time		0	-	ns
$t_{SU;STO}$	set-up time for STOP condition		0.6	-	$\mu\text{s}$
$t_{VD;DAT}$	data valid time		0	0.9	$\mu\text{s}$
$t_{VD;ACK}$	data valid acknowledge time		0	0.9	$\mu\text{s}$
$t_{SP}$	pulse width of spikes that must be suppressed by the input filter		0	50	ns

[1] A detailed description of the I<sup>2</sup>C-bus specification is given in [Ref. 12 "UM10204"](#).

[2] I<sup>2</sup>C-bus access time between two STARTs or between a START and a STOP condition to this device must be less than one second.

[3] A device must internally provide a hold time of at least 300 ns for the SDA signal (with respect to the  $V_{IH(min)}$  of the SCL signal) to bridge the undefined region of the falling edge of SCL.

[4] The maximum  $t_f$  for the SDA and SCL bus lines is specified at 300 ns. The maximum fall time for the SDA output stage  $t_f$  is specified at 250 ns. This allows series protection resistors to be connected in between the SDA and the SCL pins and the SDA/SCL bus lines without exceeding the maximum specified  $t_f$ .

Automotive Real-Time Clock/calendar with alarm function and I<sup>2</sup>C-bus

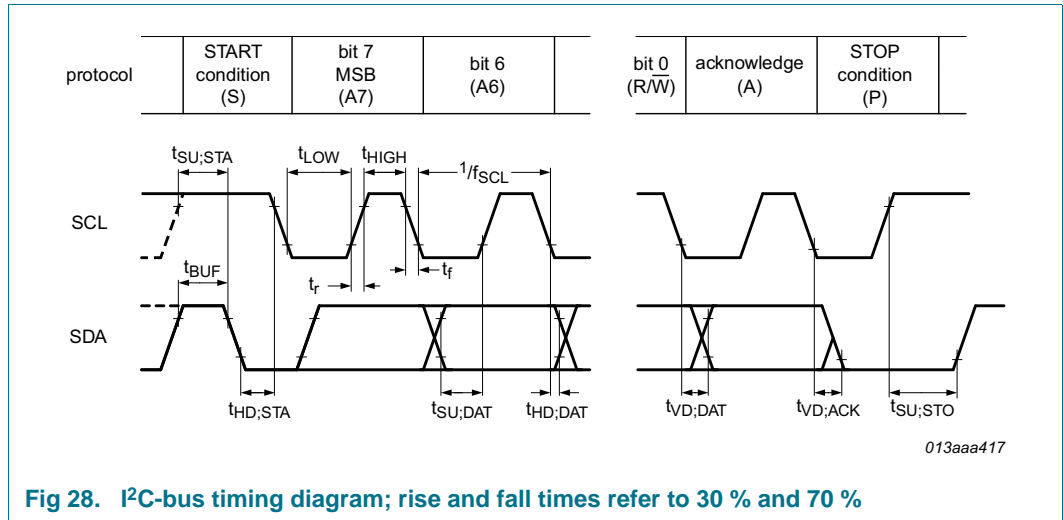

## 14. Application information

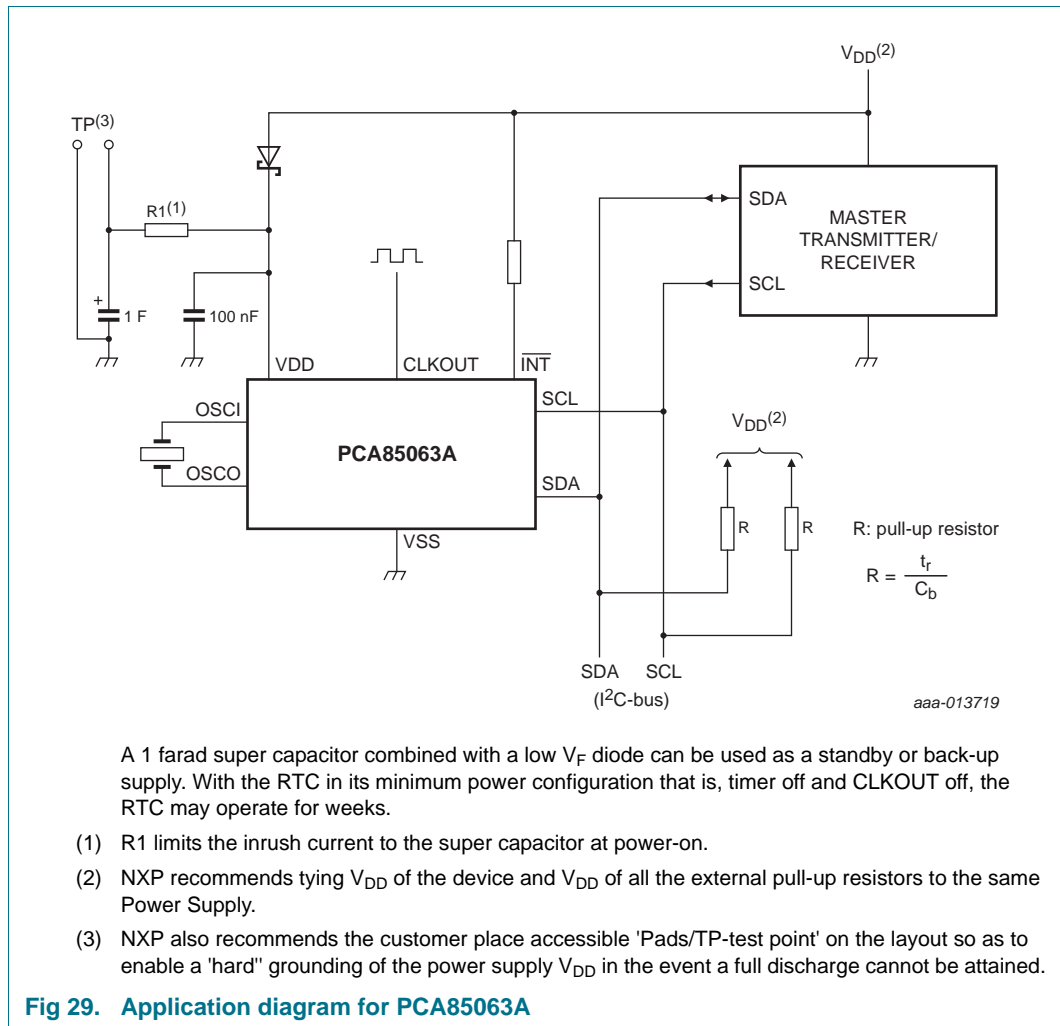

Fig 29. Application diagram for PCA85063A

## 15. Test information

### 15.1 Quality information

This product has been qualified in accordance with the Automotive Electronics Council (AEC) standard Q100 - *Failure mechanism based stress test qualification for integrated circuits*, and is suitable for use in automotive applications.

16. Package outline

TSSOP8: plastic thin shrink small outline package; 8 leads; body width 3 mm

SOT505-1

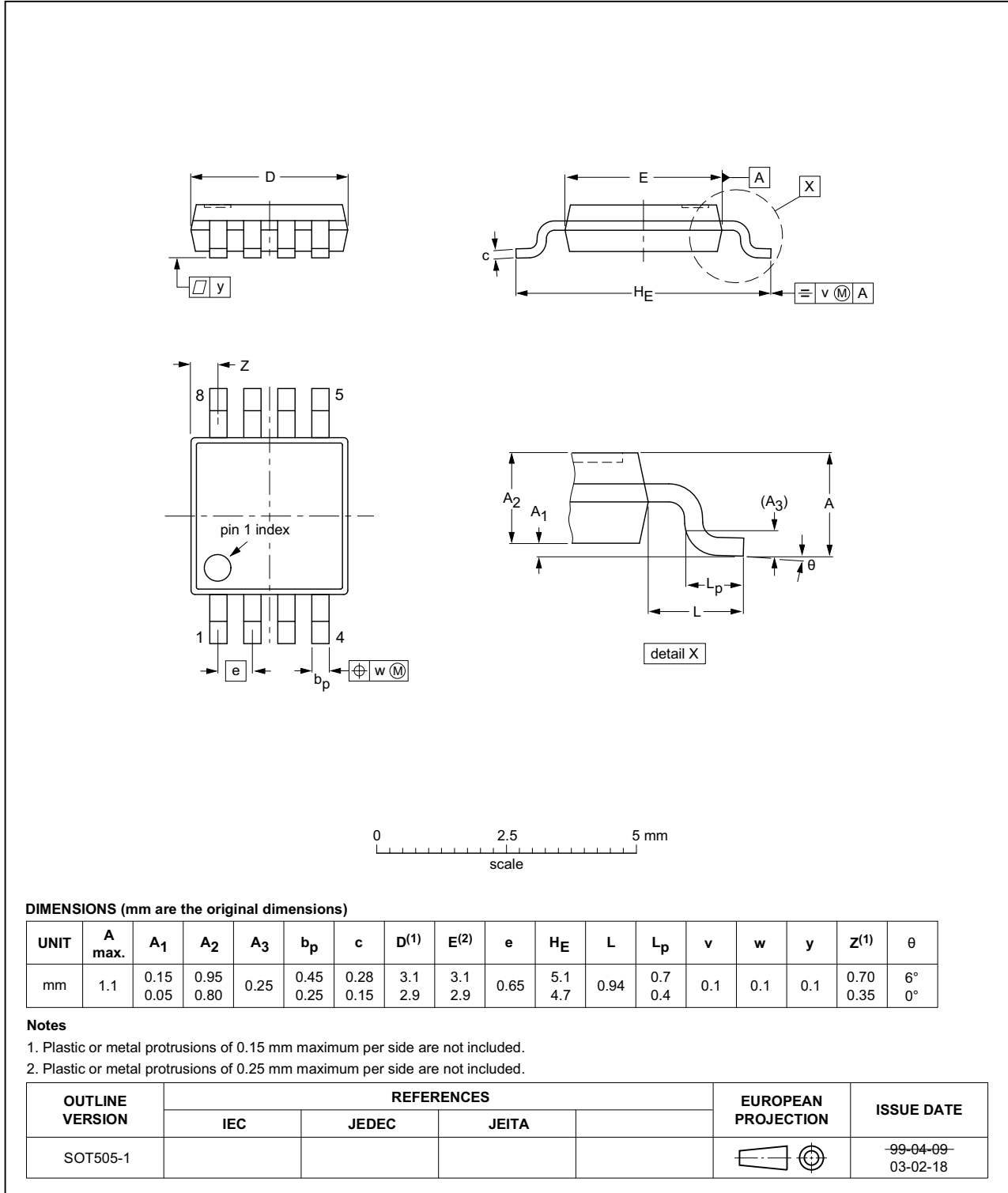

Fig 30. Package outline SOT505-1 (TSSOP8) of PCA85063ATT

## 17. Handling information

---

All input and output pins are protected against ElectroStatic Discharge (ESD) under normal handling. When handling Metal-Oxide Semiconductor (MOS) devices ensure that all normal precautions are taken as described in *JESD625-A*, *IEC 61340-5* or equivalent standards.

## 18. Packing information

---

### 18.1 Tape and reel information

For tape and reel packing information, please see [Ref. 11 "SOT505-1\\_118"](#).

## 19. Soldering of SMD packages

This text provides a very brief insight into a complex technology. A more in-depth account of soldering ICs can be found in Application Note *AN10365 "Surface mount reflow soldering description"*.

### 19.1 Introduction to soldering

Soldering is one of the most common methods through which packages are attached to Printed Circuit Boards (PCBs), to form electrical circuits. The soldered joint provides both the mechanical and the electrical connection. There is no single soldering method that is ideal for all IC packages. Wave soldering is often preferred when through-hole and Surface Mount Devices (SMDs) are mixed on one printed wiring board; however, it is not suitable for fine pitch SMDs. Reflow soldering is ideal for the small pitches and high densities that come with increased miniaturization.

### 19.2 Wave and reflow soldering

Wave soldering is a joining technology in which the joints are made by solder coming from a standing wave of liquid solder. The wave soldering process is suitable for the following:

- Through-hole components
- Leaded or leadless SMDs, which are glued to the surface of the printed circuit board

Not all SMDs can be wave soldered. Packages with solder balls, and some leadless packages which have solder lands underneath the body, cannot be wave soldered. Also, leaded SMDs with leads having a pitch smaller than ~0.6 mm cannot be wave soldered, due to an increased probability of bridging.

The reflow soldering process involves applying solder paste to a board, followed by component placement and exposure to a temperature profile. Leaded packages, packages with solder balls, and leadless packages are all reflow solderable.

Key characteristics in both wave and reflow soldering are:

- Board specifications, including the board finish, solder masks and vias
- Package footprints, including solder thieves and orientation
- The moisture sensitivity level of the packages
- Package placement
- Inspection and repair
- Lead-free soldering versus SnPb soldering

### 19.3 Wave soldering

Key characteristics in wave soldering are:

- Process issues, such as application of adhesive and flux, clinching of leads, board transport, the solder wave parameters, and the time during which components are exposed to the wave
- Solder bath specifications, including temperature and impurities

### 19.4 Reflow soldering

Key characteristics in reflow soldering are:

- Lead-free versus SnPb soldering; note that a lead-free reflow process usually leads to higher minimum peak temperatures (see [Figure 31](#)) than a SnPb process, thus reducing the process window
- Solder paste printing issues including smearing, release, and adjusting the process window for a mix of large and small components on one board
- Reflow temperature profile; this profile includes preheat, reflow (in which the board is heated to the peak temperature) and cooling down. It is imperative that the peak temperature is high enough for the solder to make reliable solder joints (a solder paste characteristic). In addition, the peak temperature must be low enough that the packages and/or boards are not damaged. The peak temperature of the package depends on package thickness and volume and is classified in accordance with [Table 43](#) and [44](#)

**Table 43. SnPb eutectic process (from J-STD-020D)**

Package thickness (mm)	Package reflow temperature (°C)	
	Volume (mm <sup>3</sup> )	
	< 350	≥ 350
< 2.5	235	220
≥ 2.5	220	220

**Table 44. Lead-free process (from J-STD-020D)**

Package thickness (mm)	Package reflow temperature (°C)		
	Volume (mm <sup>3</sup> )		
	< 350	350 to 2000	> 2000
< 1.6	260	260	260
1.6 to 2.5	260	250	245
> 2.5	250	245	245

Moisture sensitivity precautions, as indicated on the packing, must be respected at all times.

Studies have shown that small packages reach higher temperatures during reflow soldering, see [Figure 31](#).

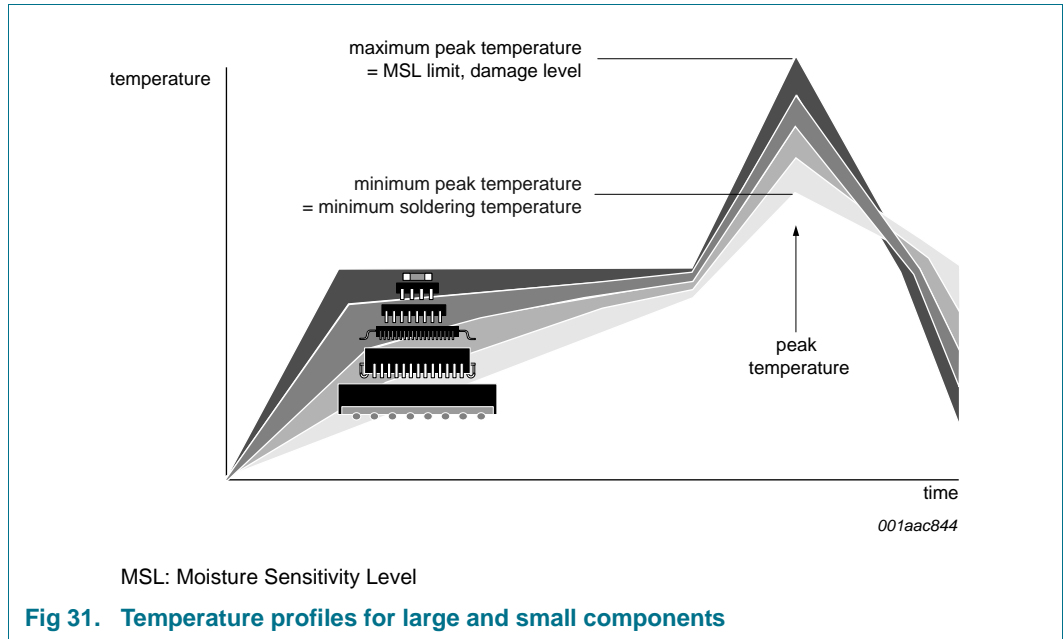

For further information on temperature profiles, refer to Application Note AN10365 “Surface mount reflow soldering description”.

## 20. Footprint information

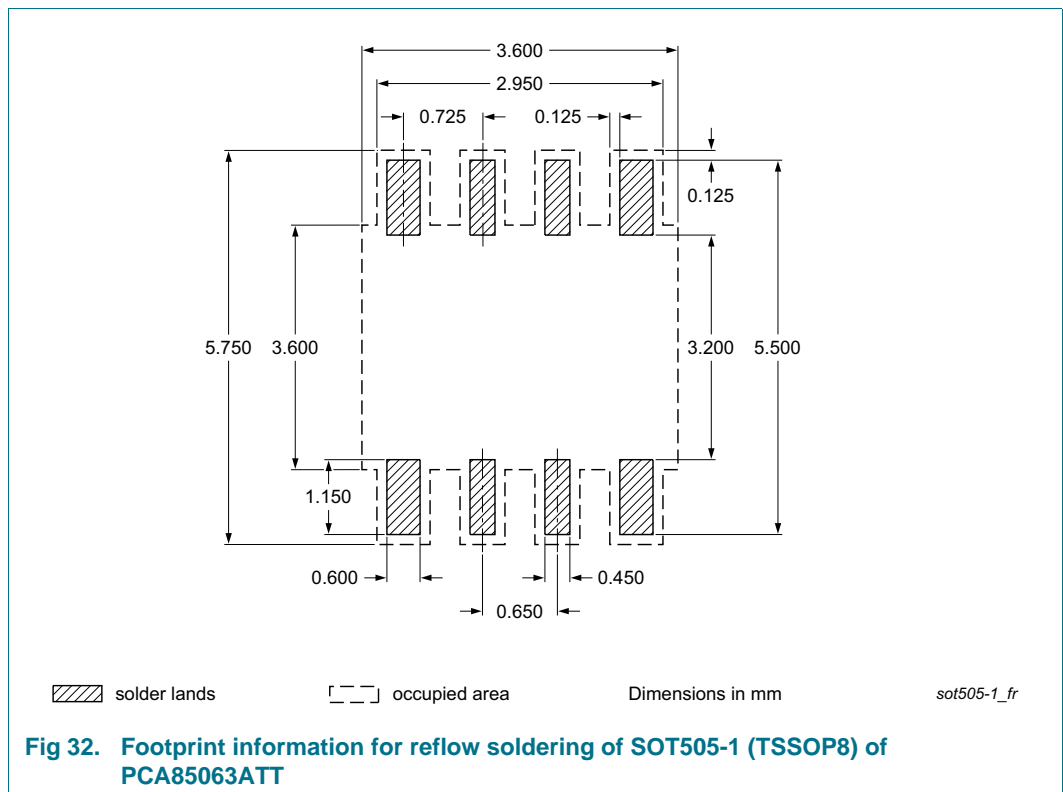

## 21.1 Real-Time Clock selection

Table 45. Selection of Real-Time Clocks

Type name	Alarm, Timer, Watchdog	Interrupt output	Interface	I <sub>DD</sub> , typical (nA)	Battery backup	Timestamp, tamper input	AEC-Q100 compliant	Special features	Package
PCF85063TP	-	1	I <sup>2</sup> C	220	-	-	-	basic functions only, no alarm	HX
PCF85063A	X	1	I <sup>2</sup> C	220	-	-	-	tiny package	SC TS
PCF85063B	X	1	SPI	220	-	-	-	tiny package	DF
PCF85263A	X	2	I <sup>2</sup> C	230	X	X	-	time stamp, battery backup, stopwatch 1/100 s	SC TS DF
PCF85263B	X	2	SPI	230	X	X	-	time stamp, battery backup, stopwatch 1/100s	TS DF
PCF85363A	X	2	I <sup>2</sup> C	230	X	X	-	time stamp, battery backup, stopwatch 1/100s, 64 Byte RAM	TS DF
PCF85363B	X	2	SPI	230	X	X	-	time stamp, battery backup, stopwatch 1/100s, 64 Byte RAM	TS DF
PCF2123	X	1	SPI	100	-	-	-	lowest power 100 nA in operation	TS
PCF8523	X	2	I <sup>2</sup> C	150	X	-	-	lowest power 150 nA in operation, FM+ 1 MHz	SC TS
PCF8563	X	1	I <sup>2</sup> C	250	-	-	-	-	SC HV
PCA8565	X	1	I <sup>2</sup> C	600	-	-	grade 1	high robustness, T <sub>amb</sub> = -40 °C to 125 °C	TS
PCA8565A	X	1	I <sup>2</sup> C	600	-	-	-	integrated oscillator caps, T <sub>amb</sub> = -40 °C to 125 °C	W
PCF8564A	X	1	I <sup>2</sup> C	250	-	-	-	integrated oscillator caps	W

**Table 45. Selection of Real-Time Clocks ...continued**

Type name	Alarm, Timer, Watchdog	Interrupt output	Interface	I <sub>DD</sub> , typical (nA)	Battery backup	Timestamp, tamper input	AEC-Q100 compliant	Special features	Package
PCF2127	X	1	I <sup>2</sup> C and SPI	500	X	X	-	temperature compensated, quartz built in, calibrated, 512 Byte RAM	SC
PCF2127A	X	1	I <sup>2</sup> C and SPI	500	X	X	-	temperature compensated, quartz built in, calibrated, 512 Byte RAM	SC
PCF2129	X	1	I <sup>2</sup> C and SPI	500	X	X	-	temperature compensated, quartz built in, calibrated	SC
PCF2129A	X	1	I <sup>2</sup> C and SPI	500	X	X	-	temperature compensated, quartz built in, calibrated	SC
PCA2129	X	1	I <sup>2</sup> C and SPI	500	X	X	grade 3	temperature compensated, quartz built in, calibrated	SC
PCA21125	X	1	SPI	820	-	-	grade 1	high robustness, T <sub>amb</sub> = -40 °C to 125 °C	TS

## 22. Abbreviations

**Table 46. Abbreviations**

Acronym	Description
BCD	Binary Coded Decimal
CMOS	Complementary Metal Oxide Semiconductor
ESD	ElectroStatic Discharge
HBM	Human Body Model
I <sup>2</sup> C	Inter-Integrated Circuit
IC	Integrated Circuit
LSB	Least Significant Bit
MSB	Most Significant Bit
MSL	Moisture Sensitivity Level
PCB	Printed-Circuit Board
POR	Power-On Reset
RTC	Real-Time Clock
SCL	Serial CLock line
SDA	Serial DAta line
SMD	Surface Mount Device

## 23. References

---

- [1] **AN10365** — Surface mount reflow soldering description
- [2] **AN10366** — HVQFN application information
- [3] **AN11247** — Improved timekeeping accuracy with PCF85063, PCF8523 and PCF2123 using an external temperature sensor
- [4] **IEC 60134** — Rating systems for electronic tubes and valves and analogous semiconductor devices
- [5] **IEC 61340-5** — Protection of electronic devices from electrostatic phenomena
- [6] **IPC/JEDEC J-STD-020** — Moisture/Reflow Sensitivity Classification for Nonhermetic Solid State Surface Mount Devices
- [7] **JESD22-A114** — Electrostatic Discharge (ESD) Sensitivity Testing Human Body Model (HBM)
- [8] **JESD22-C101** — Field-Induced Charged-Device Model Test Method for Electrostatic-Discharge-Withstand Thresholds of Microelectronic Components
- [9] **JESD78** — IC Latch-Up Test
- [10] **JESD625-A** — Requirements for Handling Electrostatic-Discharge-Sensitive (ESDS) Devices
- [11] **SOT505-1\_118** — TSSOP8; Reel pack; SMD, 13", packing information
- [12] **UM10204** — I<sup>2</sup>C-bus specification and user manual
- [13] **UM10301** — User Manual for NXP Real Time Clocks PCF85x3, PCA8565 and PCF2123, PCA2125
- [14] **UM10569** — Store and transport requirements
- [15] **UM10788** — User manual for I<sup>2</sup>C-bus RTC demo board OM13515

## 24. Revision history

Table 47. Revision history

Document ID	Release date	Data sheet status	Change notice	Supersedes
PCA85063A v.4	20180330	Product data sheet	201801008I	PCA85063A v.3
Modifications:	<ul style="list-style-type: none"> <li>• <a href="#">Table 4 "Pin description"</a>: Added <a href="#">Table note 1</a> to INT, SDA, and SCL</li> <li>• Added <a href="#">Section 9.5.3 "I<sup>2</sup>C-bus error recovery technique"</a></li> <li>• <a href="#">Table 41 "Static characteristics"</a>: Updated <a href="#">Table note 1</a></li> <li>• Updated <a href="#">Figure 29 "Application diagram for PCA85063A"</a>; added <a href="#">Figure note 2</a> and <a href="#">Figure note 3</a></li> <li>• <a href="#">Table 40 "Limiting values[1]"</a>: Added <a href="#">Table note 1</a></li> </ul>			
PCA85063A v.3	20160420	Product data sheet	-	PCA85063A v.2
Modifications:	<ul style="list-style-type: none"> <li>• Clarified reset information in <a href="#">Section 8.2</a> and <a href="#">Section 8.2.1.3</a>.</li> </ul>			
PCA85063A v.2	20150601	Product data sheet	-	PCA85063A v.1
PCA85063A v.1	20150407	Objective data sheet	-	-

## 25. Legal information

### 25.1 Data sheet status

Document status <sup>[1][2]</sup>	Product status <sup>[3]</sup>	Definition
Objective [short] data sheet	Development	This document contains data from the objective specification for product development.
Preliminary [short] data sheet	Qualification	This document contains data from the preliminary specification.
Product [short] data sheet	Production	This document contains the product specification.

[1] Please consult the most recently issued document before initiating or completing a design.

[2] The term 'short data sheet' is explained in section "Definitions".

[3] The product status of device(s) described in this document may have changed since this document was published and may differ in case of multiple devices. The latest product status information is available on the Internet at URL <http://www.nxp.com>.

### 25.2 Definitions

**Draft** — The document is a draft version only. The content is still under internal review and subject to formal approval, which may result in modifications or additions. NXP Semiconductors does not give any representations or warranties as to the accuracy or completeness of information included herein and shall have no liability for the consequences of use of such information.

**Short data sheet** — A short data sheet is an extract from a full data sheet with the same product type number(s) and title. A short data sheet is intended for quick reference only and should not be relied upon to contain detailed and full information. For detailed and full information see the relevant full data sheet, which is available on request via the local NXP Semiconductors sales office. In case of any inconsistency or conflict with the short data sheet, the full data sheet shall prevail.

**Product specification** — The information and data provided in a Product data sheet shall define the specification of the product as agreed between NXP Semiconductors and its customer, unless NXP Semiconductors and customer have explicitly agreed otherwise in writing. In no event however, shall an agreement be valid in which the NXP Semiconductors product is deemed to offer functions and qualities beyond those described in the Product data sheet.

### 25.3 Disclaimers

**Limited warranty and liability** — Information in this document is believed to be accurate and reliable. However, NXP Semiconductors does not give any representations or warranties, expressed or implied, as to the accuracy or completeness of such information and shall have no liability for the consequences of use of such information. NXP Semiconductors takes no responsibility for the content in this document if provided by an information source outside of NXP Semiconductors.

In no event shall NXP Semiconductors be liable for any indirect, incidental, punitive, special or consequential damages (including - without limitation - lost profits, lost savings, business interruption, costs related to the removal or replacement of any products or rework charges) whether or not such damages are based on tort (including negligence), warranty, breach of contract or any other legal theory.

Notwithstanding any damages that customer might incur for any reason whatsoever, NXP Semiconductors' aggregate and cumulative liability towards customer for the products described herein shall be limited in accordance with the *Terms and conditions of commercial sale* of NXP Semiconductors.

**Right to make changes** — NXP Semiconductors reserves the right to make changes to information published in this document, including without limitation specifications and product descriptions, at any time and without notice. This document supersedes and replaces all information supplied prior to the publication hereof.

**Suitability for use in automotive applications** — This NXP Semiconductors product has been qualified for use in automotive applications. Unless otherwise agreed in writing, the product is not designed, authorized or warranted to be suitable for use in life support, life-critical or safety-critical systems or equipment, nor in applications where failure or malfunction of an NXP Semiconductors product can reasonably be expected to result in personal injury, death or severe property or environmental damage. NXP Semiconductors and its suppliers accept no liability for inclusion and/or use of NXP Semiconductors products in such equipment or applications and therefore such inclusion and/or use is at the customer's own risk.

**Applications** — Applications that are described herein for any of these products are for illustrative purposes only. NXP Semiconductors makes no representation or warranty that such applications will be suitable for the specified use without further testing or modification.

Customers are responsible for the design and operation of their applications and products using NXP Semiconductors products, and NXP Semiconductors accepts no liability for any assistance with applications or customer product design. It is customer's sole responsibility to determine whether the NXP Semiconductors product is suitable and fit for the customer's applications and products planned, as well as for the planned application and use of customer's third party customer(s). Customers should provide appropriate design and operating safeguards to minimize the risks associated with their applications and products.

NXP Semiconductors does not accept any liability related to any default, damage, costs or problem which is based on any weakness or default in the customer's applications or products, or the application or use by customer's third party customer(s). Customer is responsible for doing all necessary testing for the customer's applications and products using NXP Semiconductors products in order to avoid a default of the applications and the products or of the application or use by customer's third party customer(s). NXP does not accept any liability in this respect.

**Limiting values** — Stress above one or more limiting values (as defined in the Absolute Maximum Ratings System of IEC 60134) will cause permanent damage to the device. Limiting values are stress ratings only and (proper) operation of the device at these or any other conditions above those given in the Recommended operating conditions section (if present) or the Characteristics sections of this document is not warranted. Constant or repeated exposure to limiting values will permanently and irreversibly affect the quality and reliability of the device.

**Terms and conditions of commercial sale** — NXP Semiconductors products are sold subject to the general terms and conditions of commercial sale, as published at <http://www.nxp.com/profile/terms>, unless otherwise agreed in a valid written individual agreement. In case an individual agreement is concluded only the terms and conditions of the respective agreement shall apply. NXP Semiconductors hereby expressly objects to applying the customer's general terms and conditions with regard to the purchase of NXP Semiconductors products by customer.

**No offer to sell or license** — Nothing in this document may be interpreted or construed as an offer to sell products that is open for acceptance or the grant, conveyance or implication of any license under any copyrights, patents or other industrial or intellectual property rights.

**Export control** — This document as well as the item(s) described herein may be subject to export control regulations. Export might require a prior authorization from competent authorities.

**Translations** — A non-English (translated) version of a document is for reference only. The English version shall prevail in case of any discrepancy between the translated and English versions.

## 25.4 Trademarks

Notice: All referenced brands, product names, service names and trademarks are the property of their respective owners.

**I<sup>2</sup>C-bus** — logo is a trademark of NXP B.V.

## 26. Contact information

---

For more information, please visit: <http://www.nxp.com>

For sales office addresses, please send an email to: [salesaddresses@nxp.com](mailto:salesaddresses@nxp.com)

## 27. Tables

Table 1.	Ordering information	2	Table 37.	First period delay for timer counter value T	29
Table 2.	Ordering options	2	Table 38.	$\overline{\text{INT}}$ operation	30
Table 3.	Marking codes	2	Table 39.	I <sup>2</sup> C slave address byte	33
Table 4.	Pin description	3	Table 40.	Limiting values	36
Table 5.	Registers overview	5	Table 41.	Static characteristics	37
Table 6.	Control_1 - control and status register 1 (address 00h) bit description	6	Table 42.	I <sup>2</sup> C-bus characteristics	42
Table 7.	First increment of time circuits after STOP bit release	9	Table 43.	SnPb eutectic process (from J-STD-020D)	48
Table 8.	Registers reset values	10	Table 44.	Lead-free process (from J-STD-020D)	48
Table 9.	Control_2 - control and status register 2 (address 01h) bit description	11	Table 45.	Selection of Real-Time Clocks	50
Table 10.	Effect of bits MI and HMI on $\overline{\text{INT}}$ generation	13	Table 46.	Abbreviations	52
Table 11.	CLKOUT frequency selection	14	Table 47.	Revision history	54
Table 12.	Offset - offset register (address 02h) bit description	15			
Table 13.	Offset values	15			
Table 14.	Correction pulses for MODE = 0	16			
Table 15.	Effect of correction pulses on frequencies for MODE = 0	16			
Table 16.	Correction pulses for MODE = 1	17			
Table 17.	Effect of correction pulses on frequencies for MODE = 1	17			
Table 18.	RAM_byte - 8-bit RAM register (address 03h) bit description	19			
Table 19.	Seconds - seconds register (address 04h) bit description	19			
Table 20.	Seconds coded in BCD format	20			
Table 21.	Minutes - minutes register (address 05h) bit description	21			
Table 22.	Hours - hours register (address 06h) bit description	21			
Table 23.	Days - days register (address 07h) bit description	21			
Table 24.	Weekdays - weekdays register (address 08h) bit description	21			
Table 25.	Weekday assignments	22			
Table 26.	Months - months register (address 09h) bit description	22			
Table 27.	Month assignments in BCD format	22			
Table 28.	Years - years register (0Ah) bit description	23			
Table 29.	Second_alarm - second alarm register (address 0Bh) bit description	24			
Table 30.	Minute_alarm - minute alarm register (address 0Ch) bit description	25			
Table 31.	Hour_alarm - hour alarm register (address 0Dh) bit description	25			
Table 32.	Day_alarm - day alarm register (address 0Eh) bit description	25			
Table 33.	Weekday_alarm - weekday alarm register (address 0Fh) bit description	26			
Table 34.	Timer_value - timer value register (address 10h) bit description	27			
Table 35.	Timer_mode - timer control register (address 11h) bit description	28			
Table 36.	Timer clock frequency and timer durations	28			

## 28. Figures

Fig 1.	Block diagram of PCA85063A	2
Fig 2.	Pin configuration for TSSOP8 (PCA85063ATT)	3
Fig 3.	Handling address registers	4
Fig 4.	STOP bit functional diagram	8
Fig 5.	STOP bit release timing	9
Fig 6.	Software reset command	10
Fig 7.	Interrupt scheme	12
Fig 8.	INT example for MI	13
Fig 9.	Offset calibration calculation workflow	18
Fig 10.	Result of offset calibration	19
Fig 11.	OS flag	20
Fig 12.	Data flow for the time function	23
Fig 13.	Access time for read/write operations	24
Fig 14.	Alarm function block diagram	27
Fig 15.	General countdown timer behavior	29
Fig 16.	Bit transfer	31
Fig 17.	Definition of START and STOP conditions	31
Fig 18.	System configuration	32
Fig 19.	Acknowledgement on the I <sup>2</sup> C-bus	32
Fig 20.	Master transmits to slave receiver (WRITE mode)	33
Fig 21.	Master reads after setting register address (write register address; READ data)	34
Fig 22.	Device diode protection diagram of PCA85063A	35
Fig 23.	Typical I <sub>DD</sub> with respect to f <sub>SCL</sub>	38
Fig 24.	Typical I <sub>DD</sub> as a function of temperature	39
Fig 25.	Typical I <sub>DD</sub> with respect to V <sub>DD</sub>	40
Fig 26.	I <sub>DD</sub> with respect to quartz R <sub>S</sub>	41
Fig 27.	Oscillator frequency variation with respect to V <sub>DD</sub>	41
Fig 28.	I <sup>2</sup> C-bus timing diagram; rise and fall times refer to 30 % and 70 %	43
Fig 29.	Application diagram for PCA85063A	44
Fig 30.	Package outline SOT505-1 (TSSOP8) of PCA85063ATT	45
Fig 31.	Temperature profiles for large and small components	49
Fig 32.	Footprint information for reflow soldering of SOT505-1 (TSSOP8) of PCA85063ATT	49

## 29. Contents

<b>1</b>	<b>General description</b> . . . . .	<b>1</b>	8.6.2	Register Timer_mode . . . . .	28
<b>2</b>	<b>Features and benefits</b> . . . . .	<b>1</b>	8.6.3	Timer functions . . . . .	28
<b>3</b>	<b>Applications</b> . . . . .	<b>1</b>	8.6.3.1	Countdown timer interrupts . . . . .	30
<b>4</b>	<b>Ordering information</b> . . . . .	<b>2</b>	<b>9</b>	<b>Characteristics of the I<sup>2</sup>C-bus interface</b> . . . . .	<b>31</b>
4.1	Ordering options . . . . .	2	9.1	Bit transfer . . . . .	31
<b>5</b>	<b>Marking</b> . . . . .	<b>2</b>	9.2	START and STOP conditions . . . . .	31
<b>6</b>	<b>Block diagram</b> . . . . .	<b>2</b>	9.3	System configuration . . . . .	31
<b>7</b>	<b>Pinning information</b> . . . . .	<b>3</b>	9.4	Acknowledge . . . . .	32
7.1	Pinning . . . . .	3	9.5	I <sup>2</sup> C-bus protocol . . . . .	33
7.2	Pin description . . . . .	3	9.5.1	Addressing . . . . .	33
<b>8</b>	<b>Functional description</b> . . . . .	<b>4</b>	9.5.2	Clock and calendar READ or WRITE cycles . . . . .	33
8.1	Registers organization . . . . .	5	<b>10</b>	<b>Internal circuitry</b> . . . . .	<b>35</b>
8.2	Control registers . . . . .	6	<b>11</b>	<b>Safety notes</b> . . . . .	<b>35</b>
8.2.1	Register Control_1 . . . . .	6	<b>12</b>	<b>Limiting values</b> . . . . .	<b>36</b>
8.2.1.1	EXT_TEST: external clock test mode . . . . .	7	<b>13</b>	<b>Characteristics</b> . . . . .	<b>37</b>
8.2.1.2	STOP: STOP bit function . . . . .	8	<b>14</b>	<b>Application information</b> . . . . .	<b>44</b>
8.2.1.3	Software reset . . . . .	10	<b>15</b>	<b>Test information</b> . . . . .	<b>44</b>
8.2.2	Register Control_2 . . . . .	11	15.1	Quality information . . . . .	44
8.2.2.1	Alarm interrupt . . . . .	12	<b>16</b>	<b>Package outline</b> . . . . .	<b>45</b>
8.2.2.2	MI and HMI: minute and half minute interrupt . . . . .	13	<b>17</b>	<b>Handling information</b> . . . . .	<b>46</b>
8.2.2.3	TF: timer flag . . . . .	13	<b>18</b>	<b>Packing information</b> . . . . .	<b>46</b>
8.2.2.4	COF[2:0]: Clock output frequency . . . . .	14	18.1	Tape and reel information . . . . .	46
8.2.3	Register Offset . . . . .	15	<b>19</b>	<b>Soldering of SMD packages</b> . . . . .	<b>47</b>
8.2.3.1	Correction when MODE = 0 . . . . .	16	19.1	Introduction to soldering . . . . .	47
8.2.3.2	Correction when MODE = 1 . . . . .	17	19.2	Wave and reflow soldering . . . . .	47
8.2.3.3	Offset calibration workflow . . . . .	18	19.3	Wave soldering . . . . .	47
8.2.4	Register RAM_byte . . . . .	19	19.4	Reflow soldering . . . . .	48
8.3	Time and date registers . . . . .	19	<b>20</b>	<b>Footprint information</b> . . . . .	<b>49</b>
8.3.1	Register Seconds . . . . .	19	<b>21</b>	<b>Appendix</b> . . . . .	<b>50</b>
8.3.1.1	OS: Oscillator stop . . . . .	20	21.1	Real-Time Clock selection . . . . .	50
8.3.2	Register Minutes . . . . .	21	<b>22</b>	<b>Abbreviations</b> . . . . .	<b>52</b>
8.3.3	Register Hours . . . . .	21	<b>23</b>	<b>References</b> . . . . .	<b>53</b>
8.3.4	Register Days . . . . .	21	<b>24</b>	<b>Revision history</b> . . . . .	<b>54</b>
8.3.5	Register Weekdays . . . . .	21	<b>25</b>	<b>Legal information</b> . . . . .	<b>55</b>
8.3.6	Register Months . . . . .	22	25.1	Data sheet status . . . . .	55
8.3.7	Register Years . . . . .	23	25.2	Definitions . . . . .	55
8.4	Setting and reading the time . . . . .	23	25.3	Disclaimers . . . . .	55
8.5	Alarm registers . . . . .	24	25.4	Trademarks . . . . .	56
8.5.1	Register Second_alarm . . . . .	24	<b>26</b>	<b>Contact information</b> . . . . .	<b>56</b>
8.5.2	Register Minute_alarm . . . . .	25	<b>27</b>	<b>Tables</b> . . . . .	<b>57</b>
8.5.3	Register Hour_alarm . . . . .	25	<b>28</b>	<b>Figures</b> . . . . .	<b>58</b>
8.5.4	Register Day_alarm . . . . .	25	<b>29</b>	<b>Contents</b> . . . . .	<b>59</b>
8.5.5	Register Weekday_alarm . . . . .	26			
8.5.6	Alarm function . . . . .	26			
8.6	Timer registers . . . . .	27			
8.6.1	Register Timer_value . . . . .	27			

Please be aware that important notices concerning this document and the product(s) described herein, have been included in section 'Legal information'.

## Looking for pricing, stock, or lifecycle information?

Click below to explore more details on WIN SOURCE:

- ⊖ [View PCA85063ATT/AJ on WIN SOURCE](#)
- ⊖ [NXP / Nexperia Information](#)

## Optimize Your Supply Chain with WIN SOURCE Solutions

- ✓ Global Sourcing Solution
- ✓ Obsolete Management
- ✓ Cost Control Management
- ✓ Shortage Management
- ✓ Alternative Solution
- ✓ Excess Inventory Management