



**THE DATASHEET OF
PA03A**



Power Operational Amplifiers

FEATURES

- MO-127 Copper Power DIP Package
- High Internal Power Dissipation — 500W
- High Voltage Operation — $\pm 75V$
- Very High Current — $\pm 30A$
- Internal SOA Protection
- Output Swings Close to Supply Rails
- External Shutdown Control



APPLICATIONS

- Linear and Rotary Motor Drives
- Yoke/Magnetic Field Deflection
- Programmable Power Supplies to $\pm 68V$
- Transducer/Audio to 100W

DESCRIPTION

The super power PA03 advances the state of the art in both brute force power and self-protection against abnormal operating conditions. Its features start with a copper DIP package developed by Apex Microtechnology to extend power capabilities well beyond those attainable with the familiar TO-3 package. The increased pin count of the new package provides additional control features, while the superior thermal conductivity of copper allows substantially higher power ratings.

The PA03 incorporates innovative current limiting circuits, limiting internal power dissipation to a curve approximating the safe operating area of the power transistors. The internal current limit of 35A is supplemented with thermal sensing which reduces the current limit as the substrate temperature rises. Furthermore, a subcircuit monitors actual junction temperatures and with a response time of less than ten milliseconds reduces the current limit further to keep the junction temperature at 175°C.

The PA03 also features a laser trimmed high performance FET input stage providing superior DC accuracies both initially and over the full temperature range.

Figure 1: Equivalent Schematic

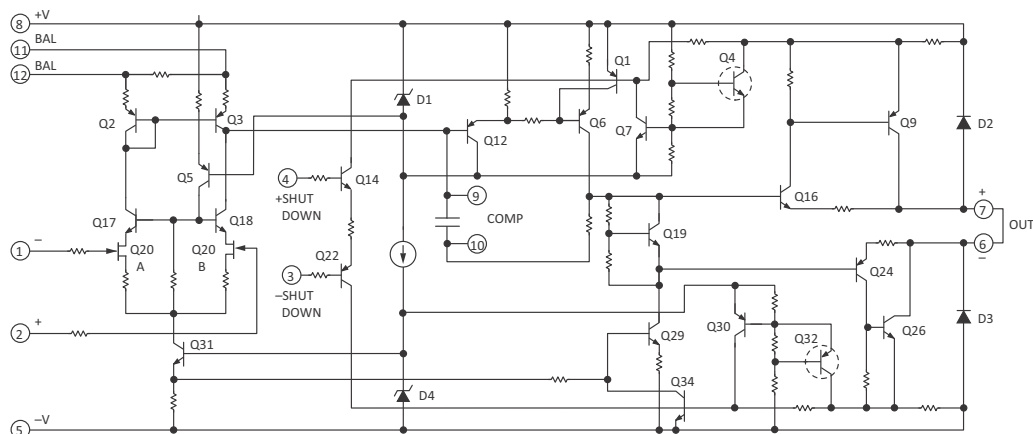

TYPICAL CONNECTION

Figure 2: Typical Connection

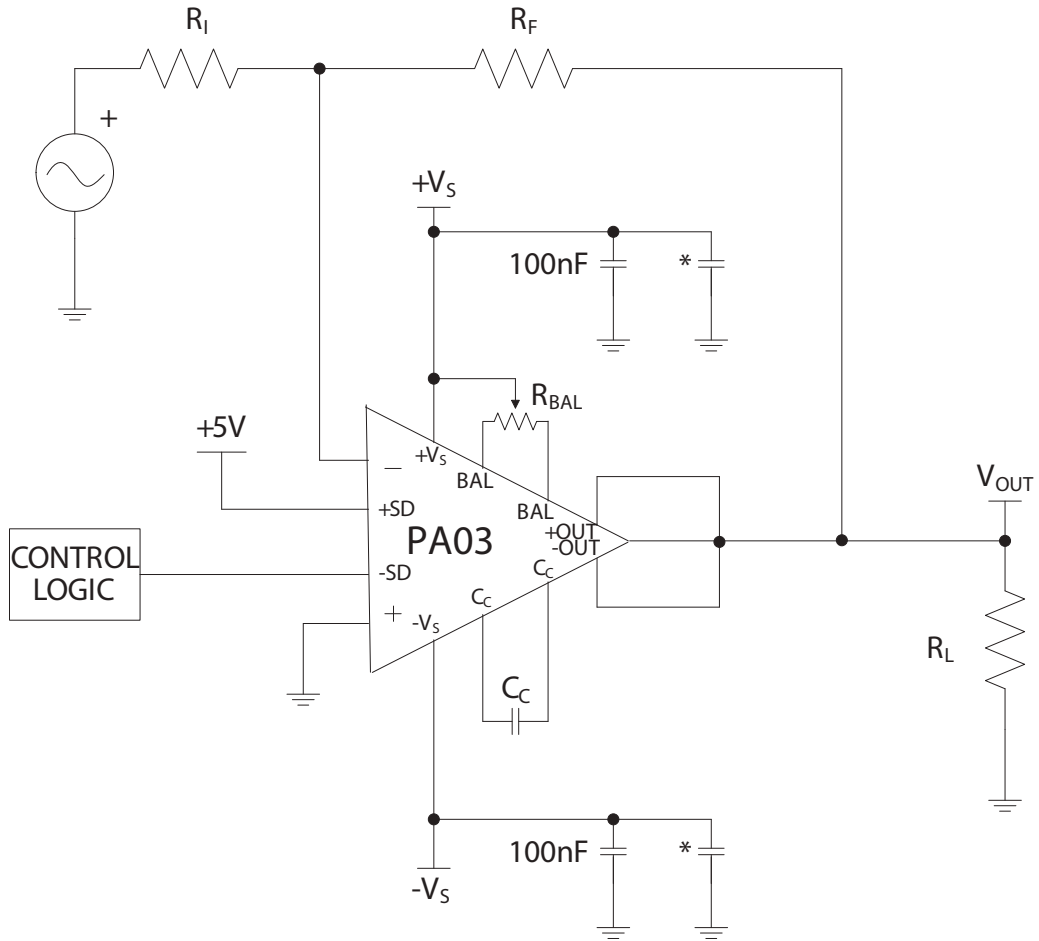

* Use 10 μ F per Amp of output current

PINOUT AND DESCRIPTION TABLE

Figure 3: External Connections

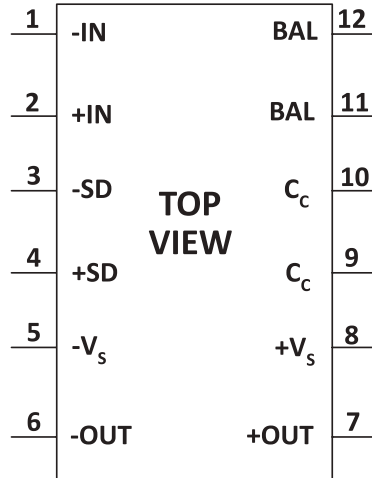

- Notes:**
- a) Pins 6 & 7 must be connected together.
 - b) If unused, tie Pins 11 & 12 to +Vs
 - c) **IMPORTANT:** Observe Mounting precautions. Reverse insertion will destroy unit.

Pin Number	Name	Description
1	-IN	The inverting input.
2	+IN	The non-inverting input.
3	-SD	The negative shut down pin. See applicable section.
4	+SD	The positive shut down pin. See applicable section.
5	-Vs	The negative supply rail.
6	-OUT	The negative output. Connect this pin to load and to the feedback resistors. Short to pin 7.
7	+OUT	The positive output. Connect this pin to load and to the feedback resistors. Short to pin 6.
8	+Vs	The positive supply rail.
9, 10	Cc	Compensation capacitor connection. Select value based on Phase Compensation. See applicable section.
11, 12	BAL	Balance Control pins. Adjusts voltage offset. Short to +Vs if unused. See applicable section.

SPECIFICATIONS

The power supply voltage for all specifications is the TYP rating unless noted as a test condition.

ABSOLUTE MAXIMUM RATINGS

Parameter	Symbol	Min	Max	Units
Supply Voltage, total	$+V_S$ to $-V_S$		150	V
Output Current, within SOA	I_{OUT}		Internally Limited	
Power Dissipation, internal	P_D		500	W
Input Voltage, differential	$V_{IN(Diff)}$		± 25	V
Input Voltage, common mode	V_{CM}		$\pm V_S$	V
Temperature, pin solder, 10s max.			350	$^{\circ}C$
Temperature, junction ¹	T_J		175	$^{\circ}C$
Temperature Range, storage		-65	+150	$^{\circ}C$
Operating Temperature Range, case	T_C	-55	+125	$^{\circ}C$
Shutdown Voltage, differential			± 5	V
Shutdown Voltage, common mode			$\pm V_S$	V

1. Long term operation at the maximum junction temperature will result in reduced product life. Derate power dissipation to achieve high MTTF.

CAUTION

The internal substrate contains beryllia (BeO). Do not break the seal. If accidentally broken, do not crush, machine, or subject to temperatures in excess of 850 $^{\circ}C$ to avoid generating toxic fumes.

INPUT

Parameter	Test Conditions	PA03			PA03A			Units
		Min	Typ	Max	Min	Typ	Max	
Offset Voltage, initial	T _C = 25°C		± 0.5	±2		± 0.25	± 0.5	mV
Offset Voltage vs. temperature	Full temp range		10	30		5	10	μV/°C
Offset Voltage vs. supply	T _C = 25°C		8			*		μV/V
Offset Voltage vs. power	Full temp range		20			10		μV/W
Bias Current, initial	T _C = 25°C		5	50		3	10	pA
Bias Current vs. supply	T _C = 25°C		0.01			*		pA/V
Offset Current, initial	T _C = 25°C		2.5	50		1.5	10	pA
Input Impedance, DC	T _C = 25°C		10 ¹¹			*		Ω
Input Capacitance	T _C = 25°C		6			*		pF
Common Mode Voltage Range ¹	Full temp range	±V _S - 10V			*			V
Common Mode Rejection, DC	Full temp range, V _{CM} = ±20V	86	108		*	*		dB
Shutdown Current ²	Full temp range		100			*		μA
Shutdown Voltage	Full temp range, amp enabled			0.85			*	V
Shutdown Voltage	Full temp range, amp disabled	3.5			*			V

1. +V_S and -V_S denote the positive and negative supply rail respectively. Total V_S is measured from +V_S to -V_S.
2. Rating applies if both shutdown inputs are least 1V inside supply rails. If one of the shutdown inputs is tied to a supply rail, the current in that pin may increase to 2.4mA.

GAIN

Parameter	Test Conditions	PA03			PA03A			Units
		Min	Typ	Max	Min	Typ	Max	
Open Loop Gain @10 Hz	Full temp range, full load	92	102		*	*		dB
Gain Bandwidth Product @ 1 MHz	T _C = 25°C, full load		1			*		MHz
Power Bandwidth	T _C = 25°C, I _{OUT} = 15A, V _{OUT} = 88V _{PP}		30			*		kHz
Phase Margin	Full temp range, C _C = 1.8nF		65			*		°

OUTPUT

Parameter	Test Conditions	PA03			PA03A			Units
		Min	Typ	Max	Min	Typ	Max	
Voltage Swing ¹	T _C =25°C, I _{OUT} =30A	± V _S - 7	6.2		*	*		V
Voltage Swing ¹	Full temp range, I _{OUT} = 12A	± V _S - 5	4.2		*	*		V
Voltage Swing ¹	Full temp range, I _{OUT} = 146mA	± V _S - 4	3.5		*	*		V
Current, peak	T _C = 25°C	30			*			A
Settling Time to 0.1%	T _C = 25°C, 10V step		8			*		μs
Slew Rate	T _C = 25°C, C _C - open		8			*		V/μs
Capacitive Load	Full temp range, A _V = 1	2			*			nF
Shutdown Delay	T _C = -25°C, disable		10			*		μs
	T _C = -25°C, operate		20			*		μs

1. +V_S and -V_S denote the positive and negative supply rail respectively. Total V_S is measured from +V_S to -V_S.

POWER SUPPLY

Parameter	Test Conditions	PA03			PA03A			Units
		Min	Typ	Max	Min	Typ	Max	
Voltage	Full temp range	± 15	± 50	± 75	*	*	*	V
Current, quiescent ¹	T _C = 25°C		125	300		*	*	mA
Current, disable mode	Full temp range		25	40		*	*	mA

1. The PA03 must be used with a heatsink or the quiescent power may drive the unit into thermal shutdown.

THERMAL

Parameter	Test Conditions	PA03			PA03A			Units
		Min	Typ	Max	Min	Typ	Max	
Resistance, AC junction to case ¹	Full temp range, F>60 Hz		0.22	0.28		*	*	°C/W
Resistance, DC junction to case	Full temp range, F<60 Hz		0.25	0.3		*	*	°C/W
Resistance, junction to ambient	Full temp range		14			*		°C/W
Temperature, junction	Sustained operation			150			*	°C
Temperature Range, case	Meets full range specs	-25		+85	*		*	°C

1. Rating applies if the output current alternates between both output transistors at a rate faster than 60 Hz.

Note: *The specification of PA03A is identical to the specification for PA03 in applicable column to the left.

TYPICAL PERFORMANCE GRAPHS

Figure 4: Power Derating

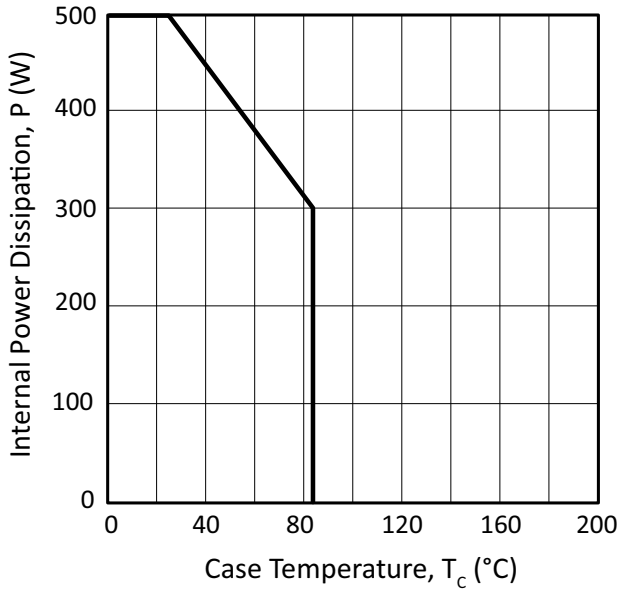

Figure 5: Bias Current

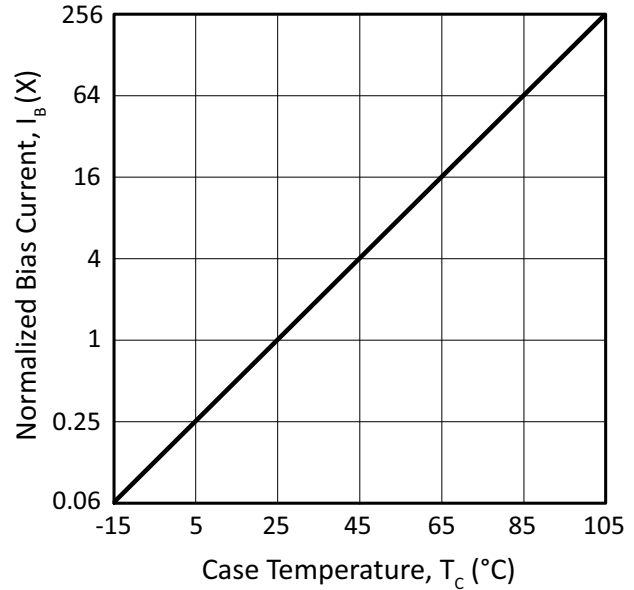

Figure 6: Small Signal Response

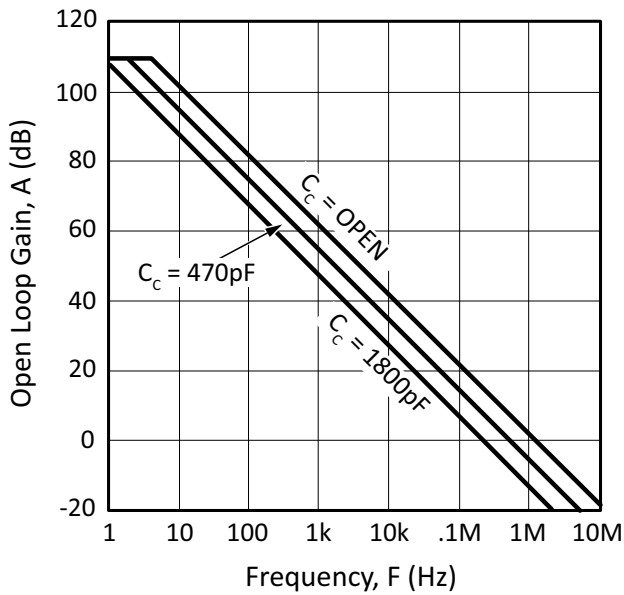

Figure 7: Phase Response

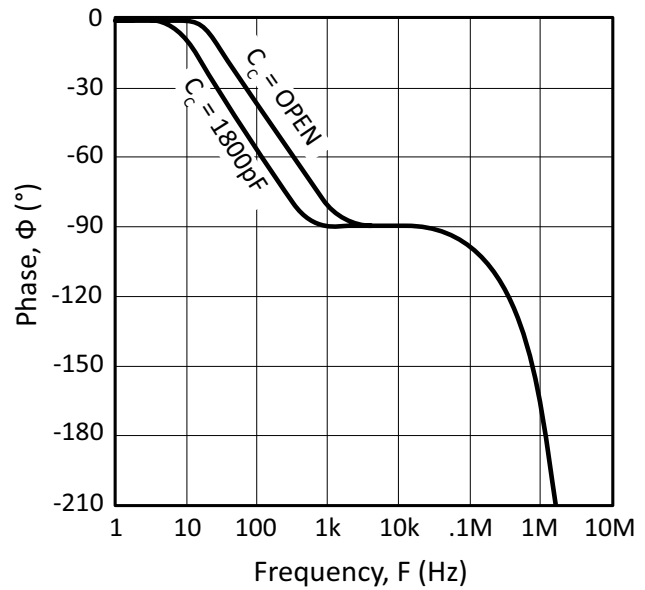

Figure 8: Current Limit

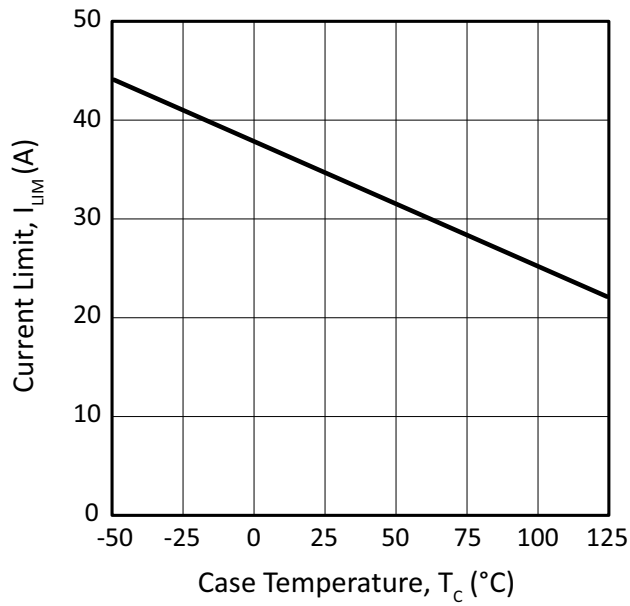

Figure 10: Output Voltage Swing

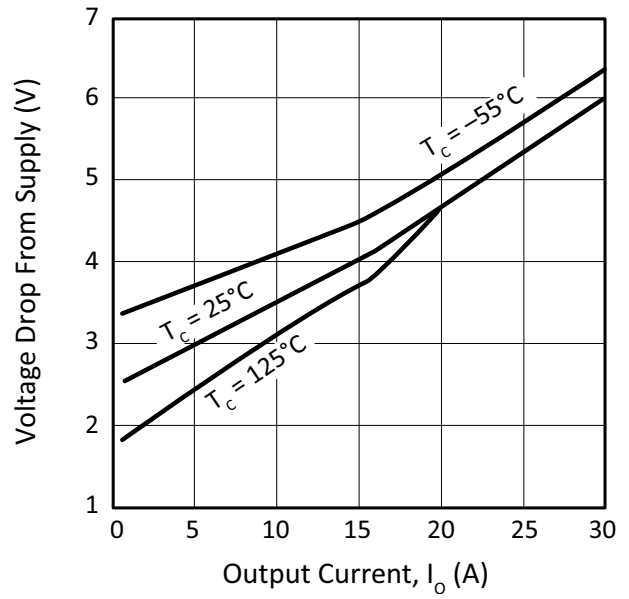

Figure 9:

Figure 11: Common Mode Rejection

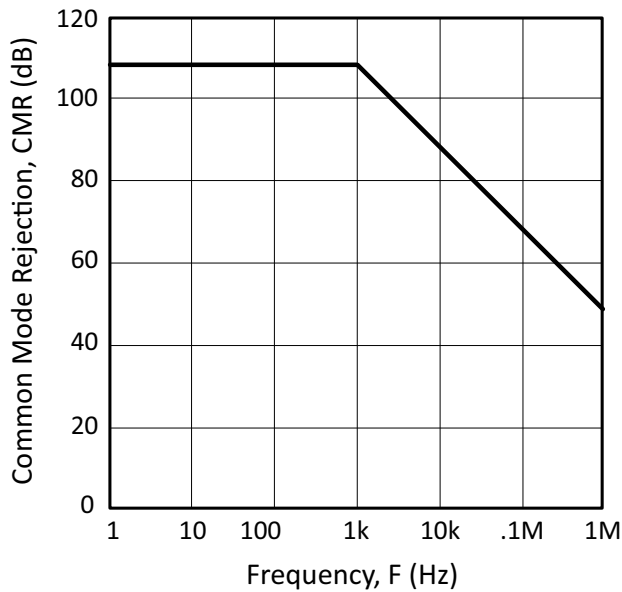

Figure 12: Pulse Response

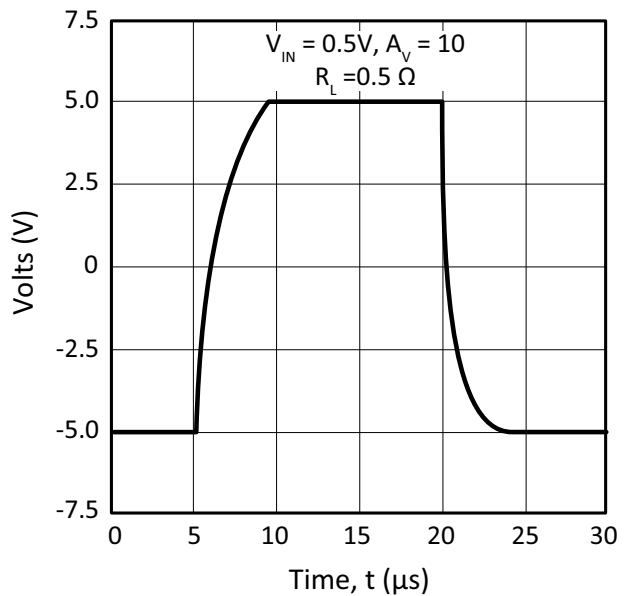

Figure 13: Input Noise

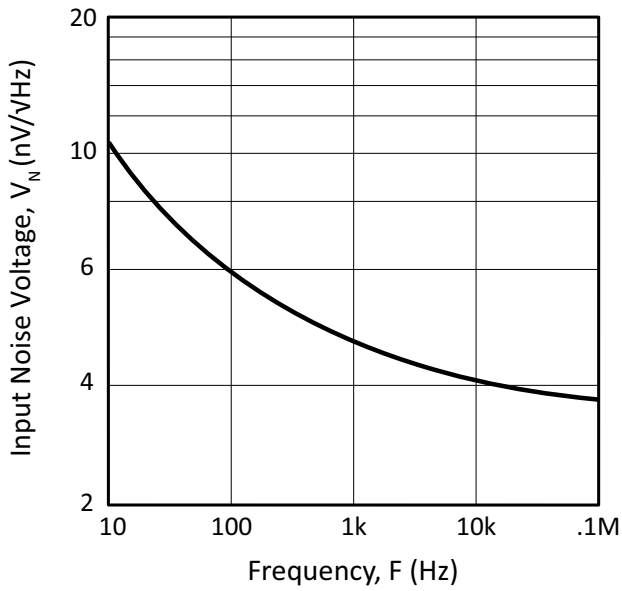

Figure 14: Harmonic Distortion

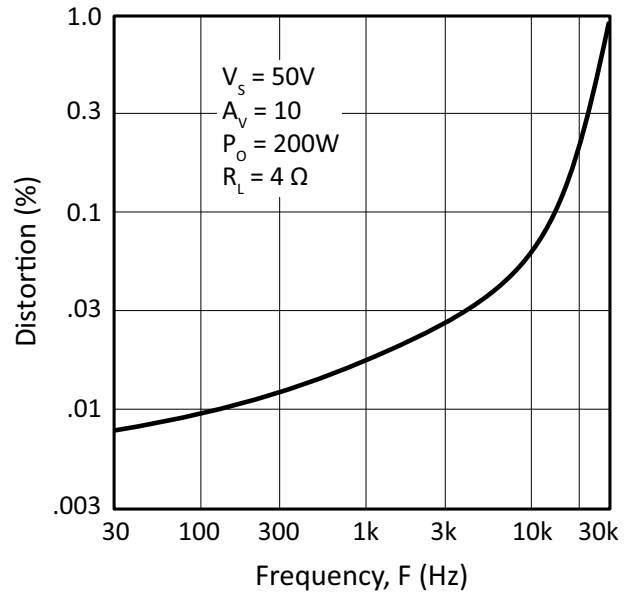

Figure 15: Quiescent Current

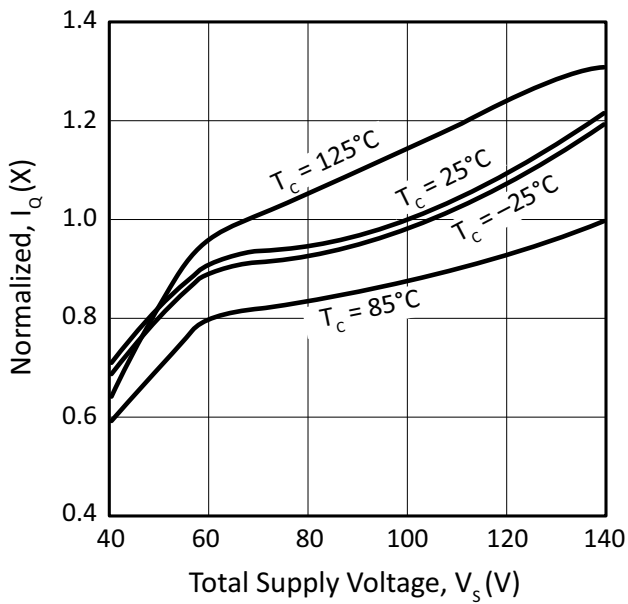
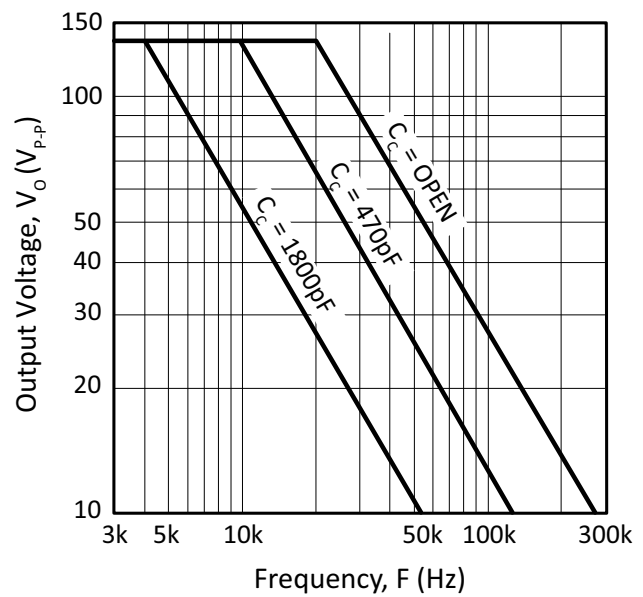

Figure 16: Power Response



SAFE OPERATING AREA (SOA)

Due to the internal (non-adjustable) current limit of the PA03, worst case power dissipation calculations must assume current capability of 46A. Application specific circuits should be checked against the SOA curve when relying upon current limit for fault protection.

Second breakdown limitations do apply to the PA03 but are less severe, since junction temperature limiting responds within 10ms. Stress levels shown as being unsafe for more than 10ms duration will merely cause thermal shutdown.

Under normal operating conditions, activation of the thermal shutdown is a sign that the internal junction temperatures have reached approximately 175°C. Thermal shutdown is a short term safety feature. If the conditions remain that cause thermal shutdown, the amplifier will oscillate in and out of shutdown, creating peak high power stresses, destroying useful signals, and reducing the reliability of the device.

Figure 17: SOA

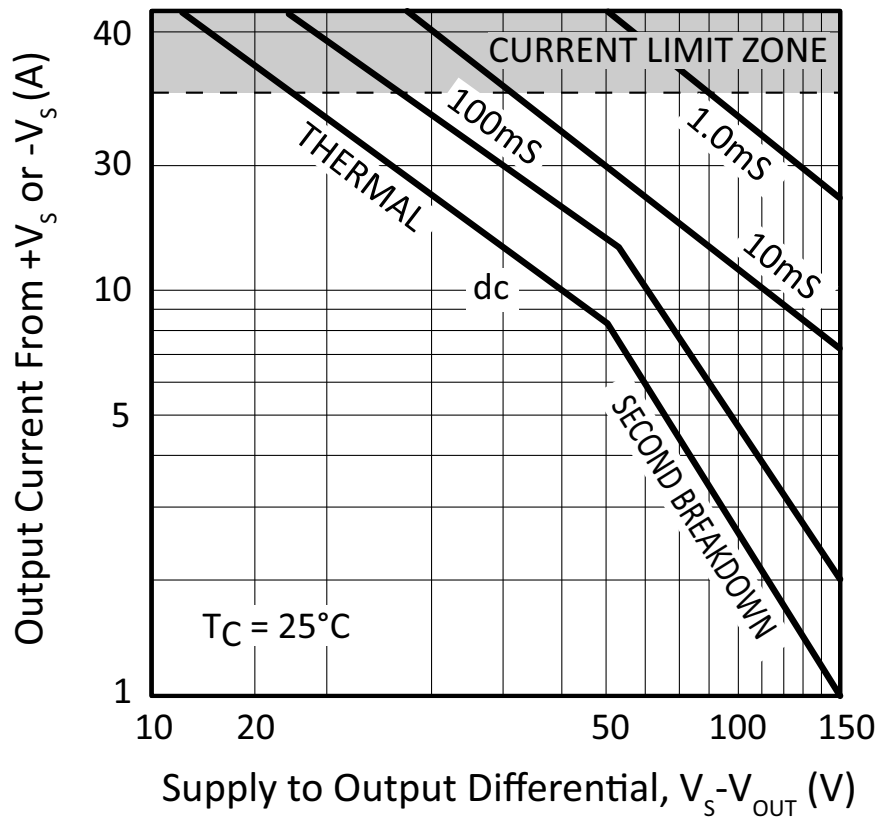

GENERAL

Please read Application Note 1 “General Operating Considerations” which covers stability, supplies, heat sinking, mounting, current limit, SOA interpretation, and specification interpretation. Visit www.apexanalog.com for Apex Microtechnology’s complete Application Notes library, Technical Seminar Workbook, and Evaluation Kits.

TYPICAL APPLICATION

The PA03 output power stages contain fast reverse recovery diodes for sustained high energy flyback protection. This hybrid integrated circuit utilizes thick film resistors, ceramic capacitors and silicon semiconductors to maximize reliability, minimize size and give top performance. Ultrasonically bonded aluminum wires provide reliable interconnections at all operating temperatures. The MO-127 Copper, 12-pin Power Dip package (see Package Outlines), is hermetically sealed and isolated from the internal circuits. Insulating washers are not recommended.

IMPORTANT: Observe mounting precautions.

Figure 18: Typical Application

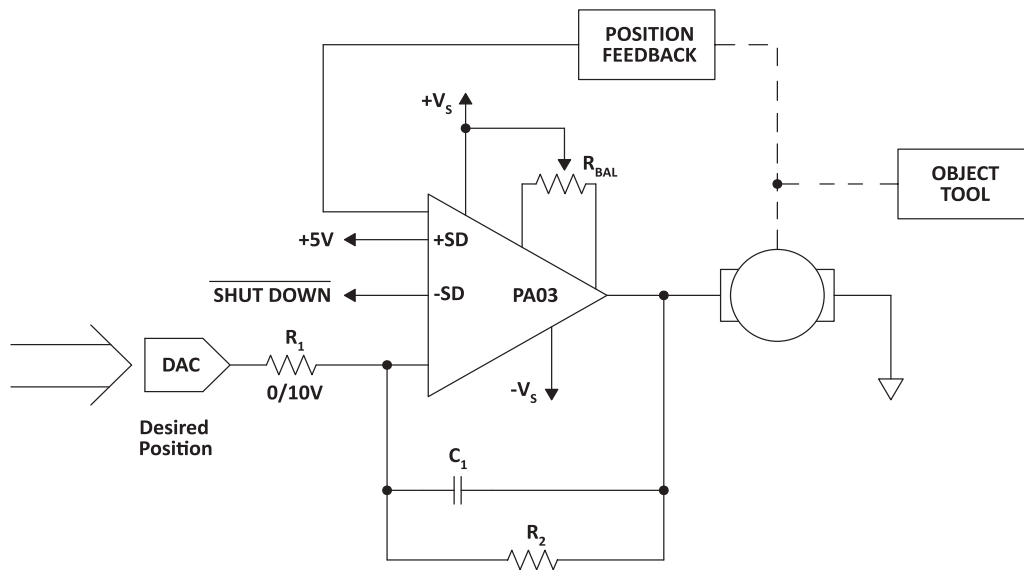

MOUNTING PRECAUTIONS

The PA03 copper base is very soft and easily bent. Do not put any stress on the mounting ears of this package. This calls for caution when pushing the amplifier into certain types of packaging foam and particularly when inserting the device into a socket. Insert the amplifier into the socket only by pushing on the perimeter of the package lid. Pushing the unit into the socket by applying pressure to the mounting tabs will bend the base due to the high insertion force required. The base will then not contact the heatsink evenly resulting in very poor heat transfer. To remove a unit from a socket, pry the socket away from the heatsink so that the heatsink will support the amplifier base evenly. Recommended mounting torque is 8–10 in. lbs. (0.9 – 1.13 N•m).

BALANCE CONTROL

The voltage offset of the PA03 may be externally adjusted to zero. To implement this adjustment install a 100 to 200 Ω potentiometer between pins 11 and 12 and connect the wiper arm to the positive supply. Bypass pins 11 and 12 each with at least a 0.01 μ F ceramic capacitor.

If the optional adjust provision is not used, connect both pins 11 and 12 to the positive supply.

OUTPUT STAGE SHUTDOWN

The entire power stage of the PA03 may be disabled using one of the circuits shown in Figure 19. There are many applications for this function. One is a load protection based on power delivered to the load or thermal rise. Another one is conservation of power when using batteries. The control voltage requirements accommodate a wide variety of logic drivers.

1. CMOS operating at +5V can drive the control pins directly.
2. CMOS operating at greater than 5V supplies need a voltage divider.
3. TTL logic needs a pull up resistor to +5V to provide a swing to the fully disabled voltage (3.5V). When not using the shutdown feature, connect both pins 3 and 4 to common.

Figure 19: Shut Down Techniques

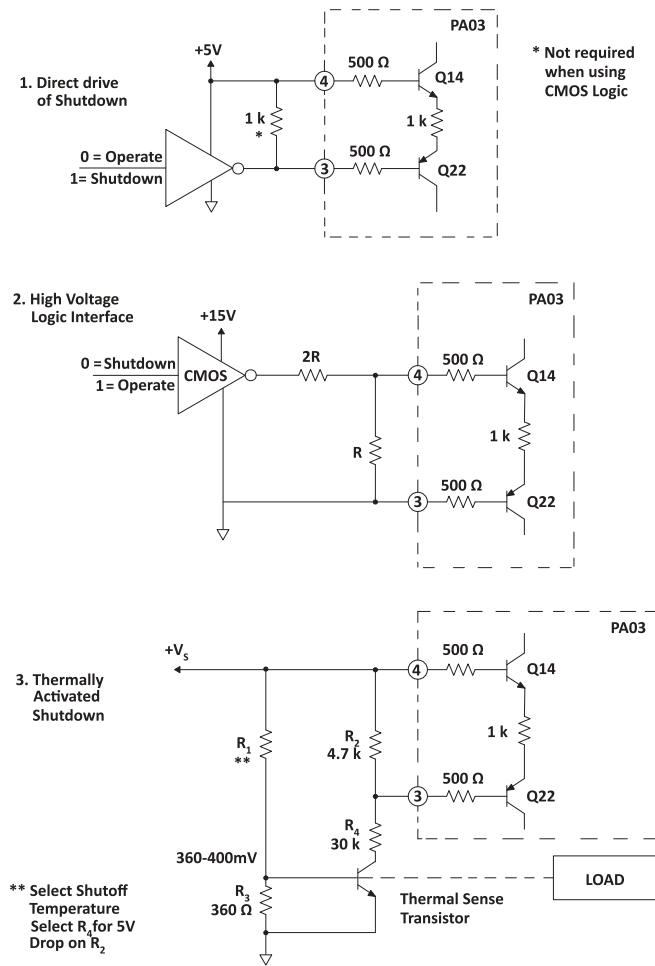

PHASE COMPENSATION

At low gain settings an external compensation capacitor is required to insure stability. In addition to the resistive feedback network, roll off or integrating capacitors must also be considered. A frequency of 1 MHz is most appropriate to calculate gain. Operation at gains below 10, without the external compensation capacitor opens the possibility of oscillations near output saturation regions when under load, the improper operation of the thermal shutdown circuit. This can result in amplifier destruction.

At gains of 10 or more:

1. No external components are required.
2. Typical slew rate will be $8\text{V}/\mu\text{s}$.
3. Typical phase margin will be 70° .

At a gain of 3:

1. Connect a 470pF compensation capacitor between pins 9 and 10.
2. Typical slew rate will be $5\text{V}/\mu\text{s}$.
3. Typical phase margin will be 45° .

At unity gain:

1. Connect a 1.8nF compensation capacitor between pins 9 and 10.
2. Typical slew rate will be $1.8\text{V}/\mu\text{s}$.
3. Typical phase margin will be 65° .

PACKAGE OPTIONS

Part Number	Apex Package Style	Description
PA03	CU	12-pin MO-127
PA03A	CU	12-pin MO-127

PACKAGE STYLE CU

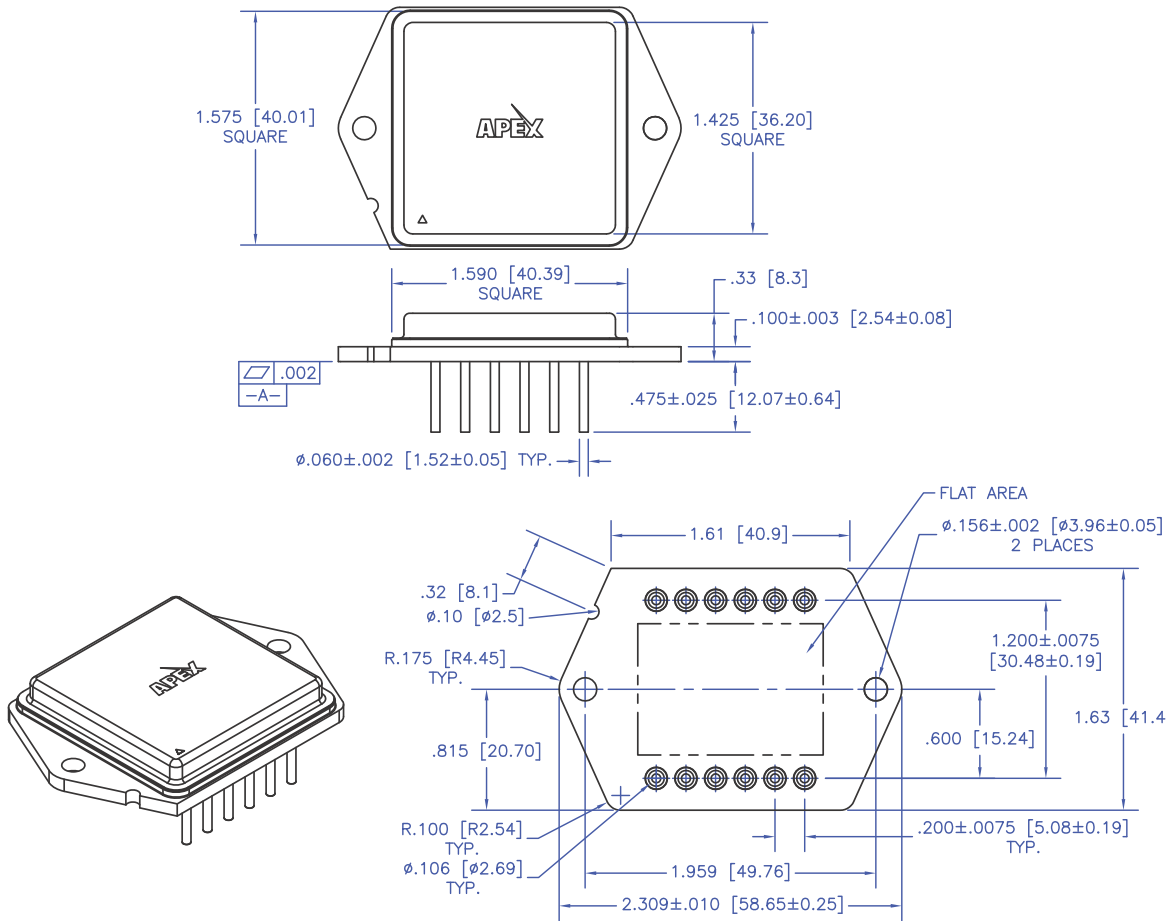

NOTES:

1. Dimensions are in inches & [mm].
2. Triangle on lid and notch in header denote pin 1.
3. Header material: Copper, with brazed-on CRS weld ring and overall nickel plating
4. Header flatness tolerance applies over rectangular area shown in bottom view.
5. Lid material: Solid nickel
6. Pin material: Solderable nickel-plated Alloy 52
7. Welded hermetic package seal
8. Isolation: 500 VDC any pin to case
9. Package weight: 2.05 oz [58 g]

NEED TECHNICAL HELP? CONTACT APEX SUPPORT!

For all Apex Microtechnology product questions and inquiries, call toll free 800-546-2739 in North America. For inquiries via email, please contact apex.support@apexanalog.com. International customers can also request support by contacting their local Apex Microtechnology Sales Representative. To find the one nearest to you, go to www.apexanalog.com

IMPORTANT NOTICE



Apex Microtechnology, Inc. has made every effort to insure the accuracy of the content contained in this document. However, the information is subject to change without notice and is provided "AS IS" without warranty of any kind (expressed or implied). Apex Microtechnology reserves the right to make changes without further notice to any specifications or products mentioned herein to improve reliability. This document is the property of Apex Microtechnology and by furnishing this information, Apex Microtechnology grants no license, expressed or implied under any patents, mask work rights, copyrights, trademarks, trade secrets or other intellectual property rights. Apex Microtechnology owns the copyrights associated with the information contained herein and gives consent for copies to be made of the information only for use within your organization with respect to Apex Microtechnology integrated circuits or other products of Apex Microtechnology. This consent does not extend to other copying such as copying for general distribution, advertising or promotional purposes, or for creating any work for resale.

APEX MICROTECHNOLOGY PRODUCTS ARE NOT DESIGNED, AUTHORIZED OR WARRANTED TO BE SUITABLE FOR USE IN PRODUCTS USED FOR LIFE SUPPORT, AUTOMOTIVE SAFETY, SECURITY DEVICES, OR OTHER CRITICAL APPLICATIONS. PRODUCTS IN SUCH APPLICATIONS ARE UNDERSTOOD TO BE FULLY AT THE CUSTOMER OR THE CUSTOMER'S RISK.

Apex Microtechnology, Apex and Apex Precision Power are trademarks of Apex Microtechnology, Inc. All other corporate names noted herein may be trademarks of their respective holders.

Looking for pricing, stock, or lifecycle information?

Click below to explore more details on WIN SOURCE:

-  [View PA03A on WIN SOURCE](#)
-  [Apex Microtechnology Information](#)

Optimize Your Supply Chain with WIN SOURCE Solutions

-  Global Sourcing Solution
-  Obsolete Management
-  Cost Control Management
-  Shortage Management
-  Alternative Solution
-  Excess Inventory Management