

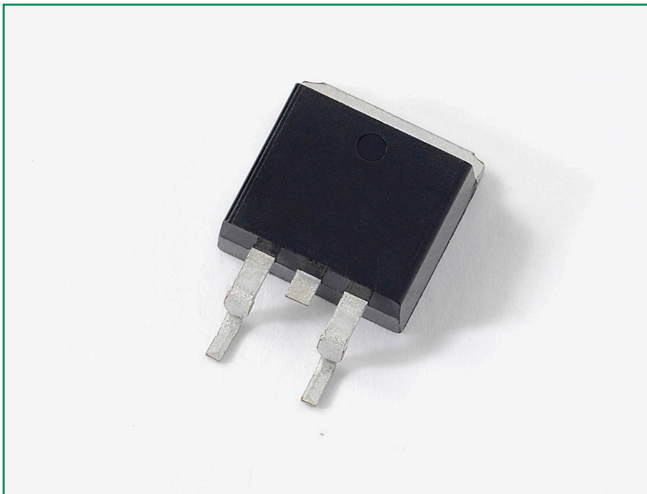

**THE DATASHEET OF
NGD18N45CLBT4G**



NGD18N45CLB - 18 A, 450 V, N-Channel Ignition IGBT, DPAK



18 Amps, 450 Volts
 $V_{CE(on)} \leq 2.1 V @$
 $I_C = 10 A, V_{GE} \geq 4.5 V$

Maximum Ratings ($T_J = 25^\circ C$ unless otherwise noted)

Rating	Symbol	Value	Unit
Collector–Emitter Voltage	V_{CES}	500	V_{DC}
Gate–Gate Voltage	V_{CER}	500	V_{DC}
Gate–Emitter Voltage	V_{GE}	18	V_{DC}
Collector Current–Continuous @ $T_C = 25^\circ C$ – Pulsed	I_C	18 50	A_{DC} A_{AC}
ESD (Human Body Model) $R = 1500 \Omega, C = 100 pF$	ESD	8.0	kV
ESD (Machine Model) $R = 0 \Omega, C = 200 pF$	ESD	400	V
Total Power Dissipation @ $T_C = 25^\circ C$ Derate above $25^\circ C$	P_D	115 0.77	W W/ $^\circ C$
Operating and Storage Temperature Range	T_J, T_{stg}	-55 to +175	$^\circ C$

Description

This Logic Level Insulated Gate Bipolar Transistor (IGBT) features monolithic circuitry integrating ESD and Over-Voltage clamped protection for use in inductive coil drivers applications. Primary uses include Ignition, Direct Fuel Injection, or wherever high voltage and high current switching is required.

Features

- Ideal for Coil-on-Plug Applications
- DPAK Package Offers Smaller Footprint for Increased Board Space
- Gate–Emitter ESD Protection
- Temperature Compensated Gate–Collector Voltage Clamp Limits Stress Applied to Load
- Low Threshold Voltage Interfaces Power Loads to Logic or Microprocessor Devices
- Low Saturation Voltage
- High Pulsed Current Capability
- Emitter Ballasting for Short–Circuit Capability
- This is a Pb–Free Device

Functional Diagram

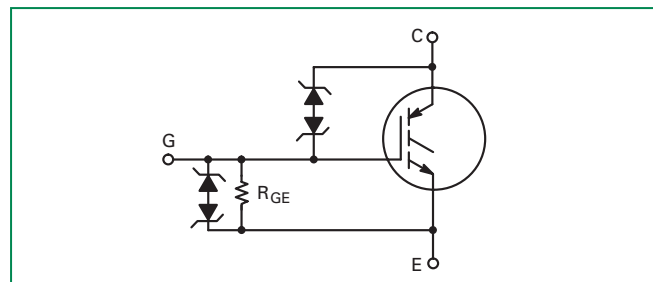

Additional Information



Datasheet



Resources



Samples

Stresses exceeding Maximum Ratings may damage the device. Maximum Ratings are stress ratings only. Functional operation above the Recommended Operating Conditions is not implied. Extended exposure to stresses above the Recommended Operating Conditions may affect device reliability.

Unclamped Collector–To–Emitter Avalanche Characteristics (Note 2)

	Symbol	Value	Unit
Single Pulse Collector–to–Emitter Avalanche Energy			
$V_{CC} = 50\text{ V}, V_{GE} = 5.0\text{ V}, P_k I_L = 26.0\text{ A}, R_G = 1000\ \Omega, L = 1.0\text{ mH}, \text{Starting } T_J = 25^\circ\text{C}$	E_{AS}	338	mJ
$V_{CC} = 50\text{ V}, V_{GE} = 5.0\text{ V}, P_k I_L = 10.0\text{ A}, R_G = 1000\ \Omega, L = 8.4\text{ mH}, \text{Starting } T_J = 25^\circ\text{C}$		420	
$V_{CC} = 50\text{ V}, V_{GE} = 5.0\text{ V}, P_k I_L = 15.4\text{ A}, R_G = 1000\ \Omega, L = 2.0\text{ mH}, \text{Starting } T_J = 150^\circ\text{C}$		237	
$V_{CC} = 50\text{ V}, V_{GE} = 5.0\text{ V}, P_k I_L = 5.7\text{ A}, R_G = 1000\ \Omega, L = 15.2\text{ mH}, \text{Starting } T_J = 150^\circ\text{C}$		247	

Thermal Characteristics

	Symbol	Value	Unit
Thermal Resistance, Junction to Case	$R_{\theta JC}$	1.3	°C/W
Thermal Resistance, Junction to Ambient DPAK (Note 1)	$R_{\theta JA}$	95	
Maximum Lead Temperature for Soldering Purposes, 1/8" from case for 5 seconds	T_L	275	°C

Maximum Short-Circuit Times

Rating	Symbol	Value	Unit
Short Circuit Withstand Time – Test 1 (See Figure 17, 3 Pulses with 10 ms Period, $T_a = 105^\circ\text{C}$)	t_{sc1-1}	1000	μS
Short Circuit Withstand Time – Test 1 (See Figure 17, 3 Pulses with 10 ms Period, $T_a = 150^\circ\text{C}$)	t_{sc1-2}	800	μS
Short Circuit Withstand Time – Test 2 (See Figure 18, 3 Pulses with 10 ms Period, $T_a = 105^\circ\text{C}$)	t_{sc2-1}	5	ms
Short Circuit Withstand Time – Test 2 (See Figure 18, 3 Pulses with 10 ms Period, $T_a = 150^\circ\text{C}$)	t_{sc2-2}	1	ms

Electrical Characteristics - OFF (Note 2)

Characteristic	Symbol	Test Conditions	Temperature	Min	Typ	Max	Unit
Collector–Emitter Clamp Voltage	BV_{CES}	$I_C = 2.0 \text{ mA}$	$T_J = -40^\circ\text{C to } 150^\circ\text{C}$	430	455	470	V_{DC}
		$I_C = 10 \text{ mA}$	$T_J = -40^\circ\text{C to } 150^\circ\text{C}$	440	475	500	
Zero Gate Voltage Collector Current	$iECS$	$V_{CE} = 350 \text{ V}$ $V_{GE} = 0 \text{ V}$	$T_J = 25^\circ\text{C}$	–	0.5	20	μA_{DC}
			$T_J = 150^\circ\text{C}$	–	75	250	
			$T_J = -40^\circ\text{C}$	–	0.2	10	
		$V_{CE} = 15 \text{ V}$ $V_{GE} = 0 \text{ V}$	$T_J = 25^\circ\text{C}$	–	–	2.0	
Reverse Collector–Emitter Leakage Current	I_{CES}	$V_{CE} = -24 \text{ V}$	$T_J = 25^\circ\text{C}$	–	0.7	1.0	mA
			$T_J = 150^\circ\text{C}$	–	12	25	
			$T_J = -40^\circ\text{C}$	–	0.1	1.0	
Reverse Collector–Emitter Clamp Voltage	$BV_{CES(R)}$	$I_C = -75 \text{ mA}$	$T_J = 25^\circ\text{C}$	24	27	30	V_{DC}
			$T_J = 150^\circ\text{C}$	26	29	33	
			$T_J = -40^\circ\text{C}$	23	26	29	
Gate–Emitter Clamp Voltage	BV_{GES}	$I_G = 5.0 \text{ mA}$	$T_J = -40^\circ\text{C to } 150^\circ\text{C}$	11	13	15	V_{DC}
Gate–Emitter Leakage Current	I_{GES}	$V_{GE} = \pm 10 \text{ V}$	$T_J = -40^\circ\text{C to } 150^\circ\text{C}$	384	590	700	μA_{DC}
Gate-Emitter Resistor	R_{GE}	–	$T_J = -40^\circ\text{C to } 150^\circ\text{C}$	10	16	26	k Ω

1. When surface mounted to an FR4 board using the minimum recommended pad size.

Electrical Characteristics - ON (Note 2)

Characteristic	Symbol	Test Conditions	Temperature	Min	Typ	Max	Unit
Gate Threshold Voltage	$V_{GE(th)}$	$I_C = 1.0\text{ mA}$, $V_{GE} = V_{CE}$	$T_J = 25^\circ\text{C}$	1.1	1.56	1.9	V_{DC}
			$T_J = 150^\circ\text{C}$	0.75	1.08	1.4	
			$T_J = -40^\circ\text{C}$	1.2	1.75	2.1	
Threshold Temperature Coefficient (Negative)	-	-	-	-	3.5	-	mV/°C
Collector-to-Emitter On-Voltage	$V_{CE(on)}$	$V_{CE} = 4.5\text{ V}$, $I_C = 7\text{ A}$	$T_J = -40^\circ\text{C to } 150^\circ\text{C}$	1.10	1.84	2.30	V_{DC}
			$T_J = -40^\circ\text{C to } 150^\circ\text{C}$	1.15	1.89	2.35	
			$T_J = -40^\circ\text{C to } 150^\circ\text{C}$	1.20	1.93	2.50	
			$T_J = -40^\circ\text{C to } 150^\circ\text{C}$	1.45	2.07	2.65	
			$T_J = -40^\circ\text{C to } 150^\circ\text{C}$	1.50	2.13	2.80	
			$T_J = -40^\circ\text{C to } 150^\circ\text{C}$	1.55	2.19	2.85	
			$T_J = -40^\circ\text{C to } 150^\circ\text{C}$	-	0.65	1.00	
Forward Transconductance	gfs	$V_{CE} = 5.0\text{ V}$, $I_C = 6.0\text{ A}$	$T_J = -40^\circ\text{C to } 150^\circ\text{C}$	6.0	14	25	Mhos

Dynamic Characteristics

Characteristic	Symbol	Test Conditions	Temperature	Min	Typ	Max	Unit
Input Capacitance	C_{ISS}	$V_{CC} = 25\text{ V}$ $V_{GE} = 0\text{ V}$ $f = 1.0\text{ MHz}$	$T_J = -40^\circ\text{C}$ to 150°C	400	780	1000	pF
Output Capacitance	C_{OSS}			50	72	100	
Transfer Capacitance	C_{RSS}			4.0	6	10	

Switching Characteristics (Note 2)

Characteristic	Symbol	Test Conditions	Temperature	Min	Typ	Max	Unit
Turn-Off Delay Time	$t_{d(off)}$	$V_{CC} = 300\text{ V}$ $V_{GE} = 0\text{ V}$ $R_G = 1.0\text{ k}\Omega$ $R_L = 46\ \Omega$	$T_J = 25^\circ\text{C}$	1.0	2.9	12	μSec
Fall Time	t_f	$V_{CC} = 300\text{ V}$ $V_{GE} = 5\text{ V}$ $R_G = 1.0\text{ k}\Omega$ $R_L = 46\ \Omega$	$T_J = 25^\circ\text{C}$	1.0	2.5	7.0	
Turn-On Delay Time	$t_{d(on)}$	$V_{CC} = 14\text{ V}$ $V_{GE} = 5\text{ V}$ $R_G = 1.0\text{ k}\Omega$ $R_L = 1\ \Omega$	$T_J = 25^\circ\text{C}$	0.1	0.42	1.4	
Rise Time	t_r	$V_{CC} = 14\text{ V}$ $V_{GE} = 5\text{ V}$ $R_G = 1.0\text{ k}\Omega$ $R_L = 1\ \Omega$	$T_J = 25^\circ\text{C}$	1.0	2.5	9.0	

2. Electrical Characteristics at temperature other than 25°C, Dynamic and Switching characteristics are not subject to production testing. Product parametric performance is indicated in the Electrical Characteristics for the listed test conditions, unless otherwise noted. Product performance may not be indicated by the Electrical Characteristics if operated under different conditions.

Typical Electrical Characteristics (unless otherwise noted)

Figure 1. Output Characteristics

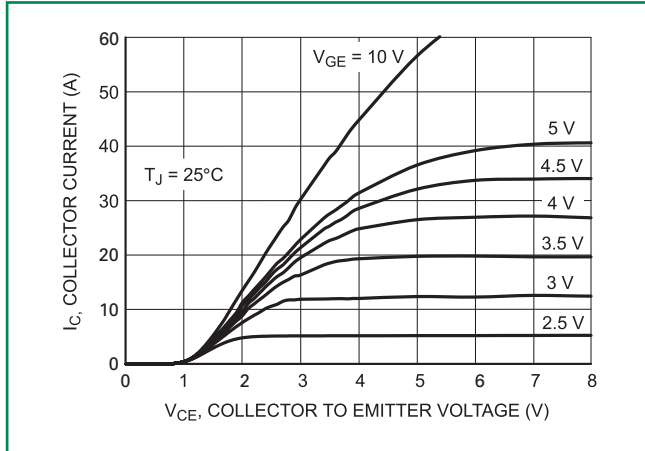

Figure 2. Output Characteristics

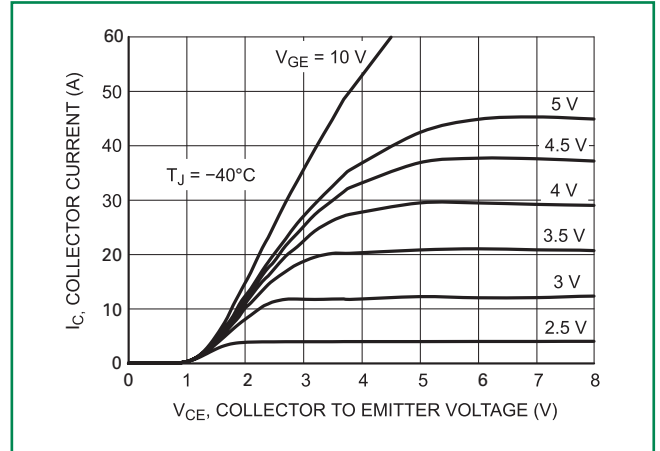

Figure 3. Output Characteristics

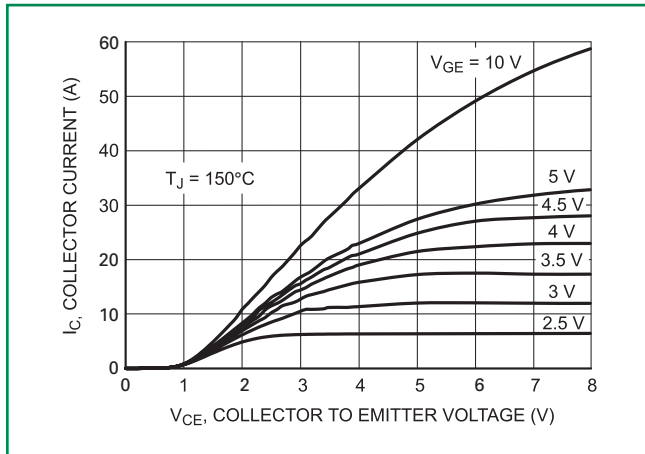

Figure 4. Transfer Characteristics

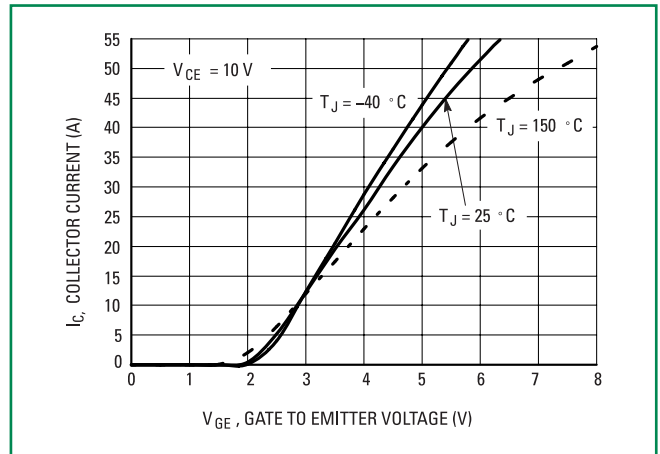

Figure 5. Collector-to-Emitter Saturation Voltage vs. Junction Temp

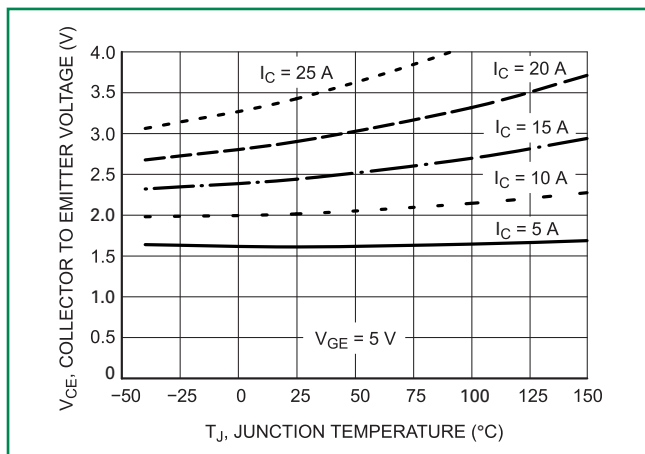

Figure 6. Collector-to-Emitter Voltage versus Gate-to-Emitter

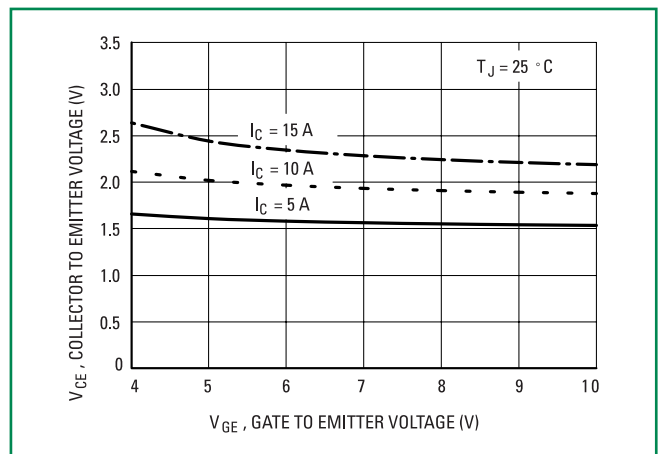

Figure 7. Collector-to-Emitter Voltage vs Gate-to-Emitter Voltage

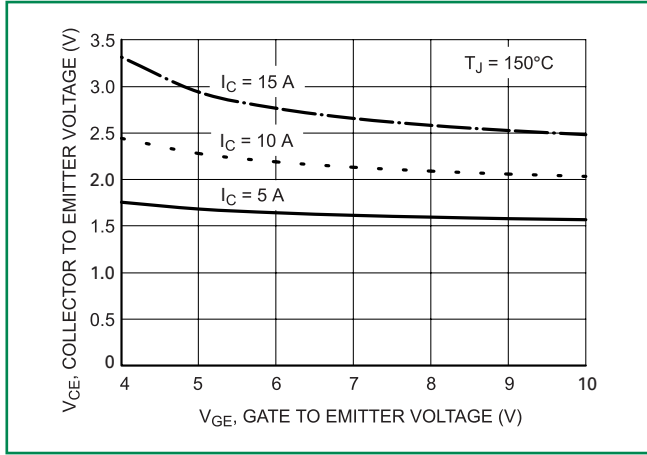

Figure 8. Capacitance Variation

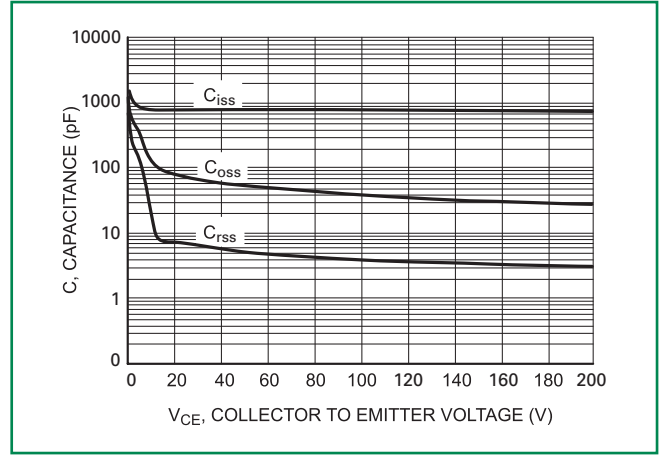

Figure 9. Gate Threshold Voltage vs. Junction Temperature

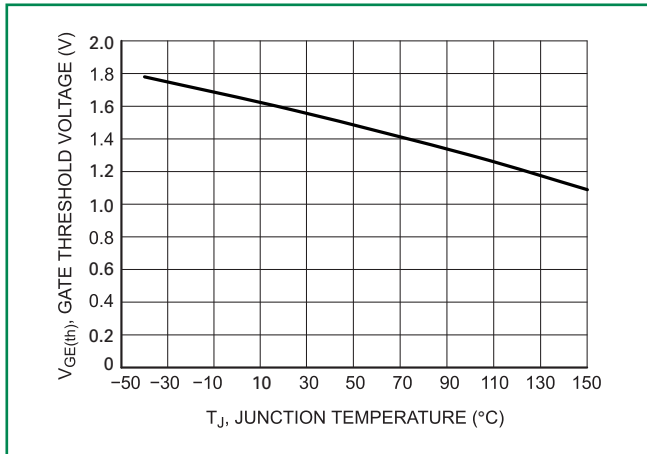

Figure 10. Minimum Open Secondary Latch Current vs. Inductance

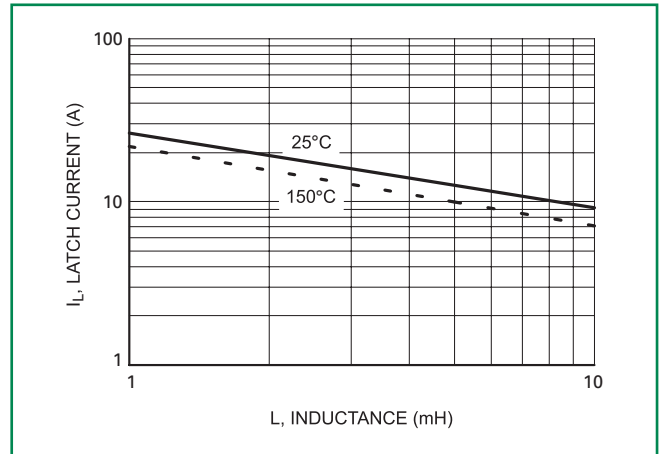

Figure 11. Typical Open Secondary Latch Current vs. Inductance

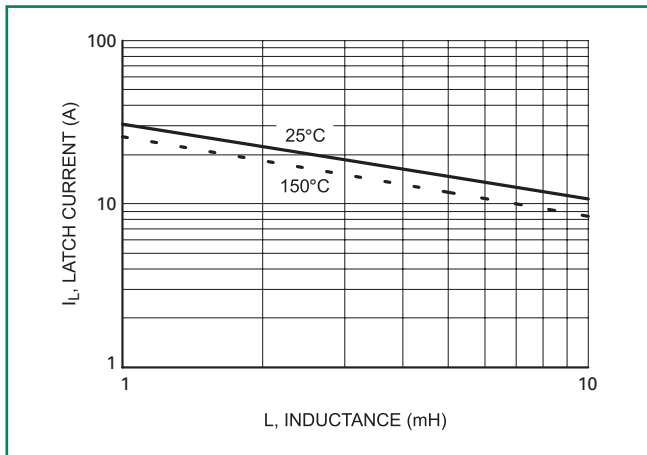

Figure 12. Inductive Switching Fall Time vs. Temperature

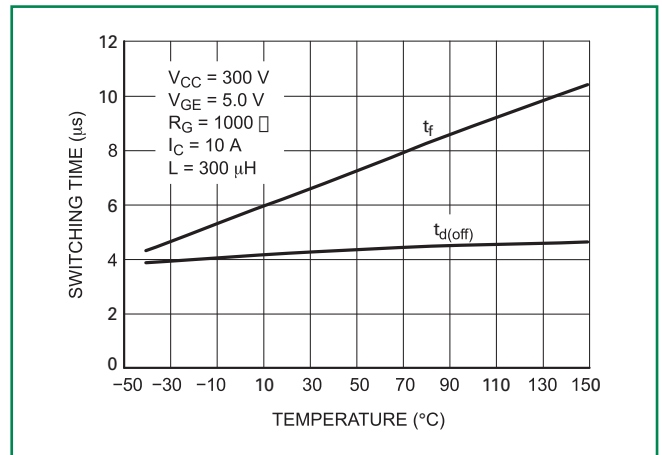

Figure 13. Single Pulse Safe Operating Area
(Mounted on an Infinite Heatsink at $T_A = 25^\circ\text{C}$)

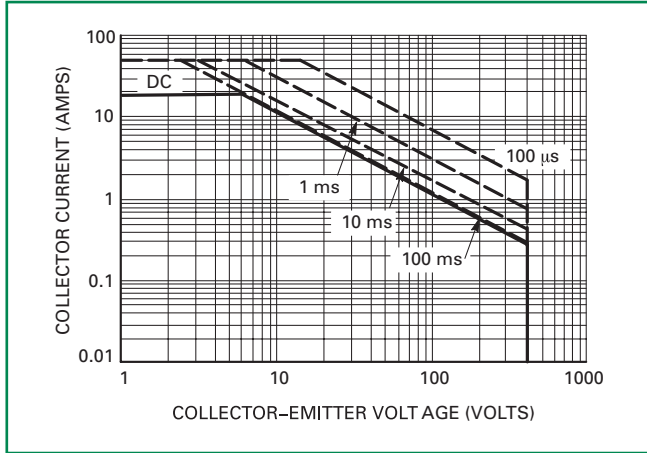

Figure 14. Single Pulse Safe Operating Area
(Mounted on an Infinite Heatsink at $T_A = 125^\circ\text{C}$)

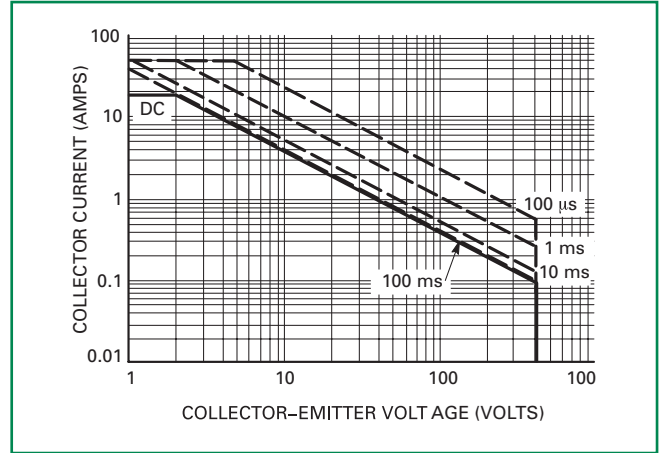

Figure 15. Pulse Train Safe Operating Area
(Mounted on an Infinite Heatsink at $T_C = 25^\circ\text{C}$)

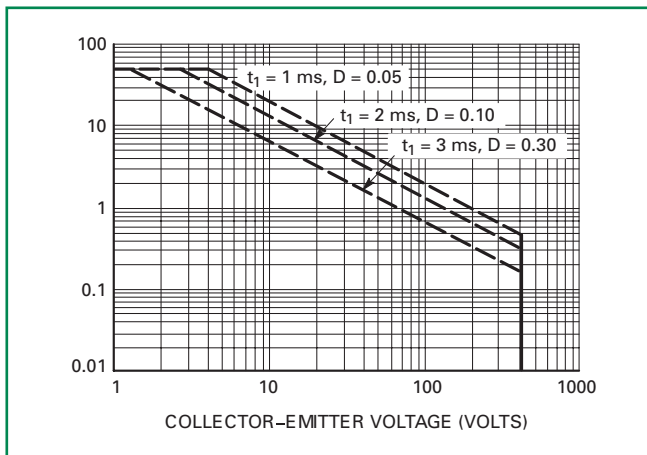

Figure 16. Pulse Train Safe Operating Area
(Mounted on an Infinite Heatsink at $T_C = 25^\circ\text{C}$)

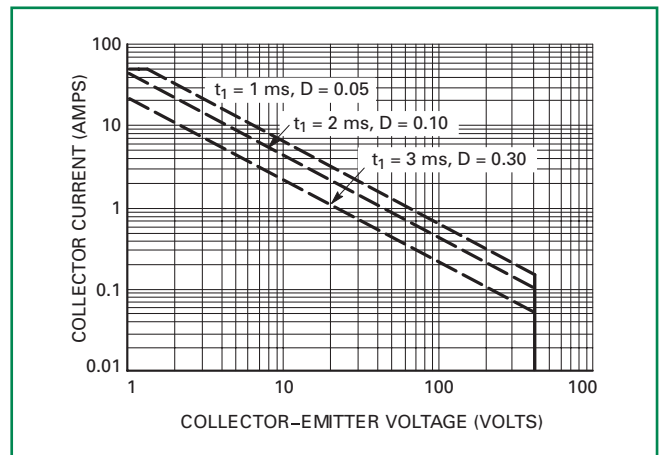

Figure 17. Circuit Configuration for Short Circuit Test #1

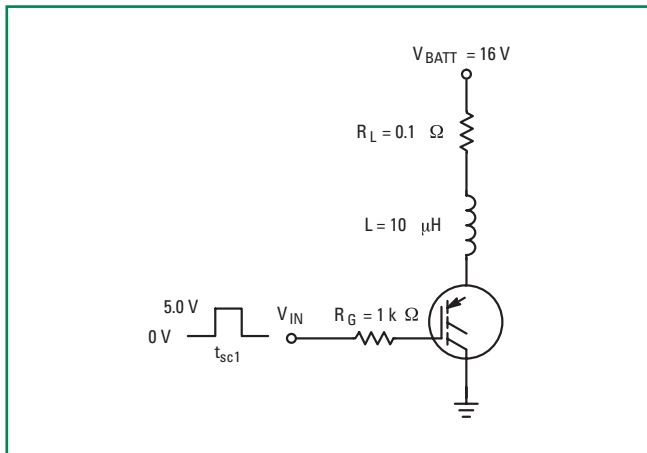

Figure 18. Circuit Configuration for Short Circuit Test #2

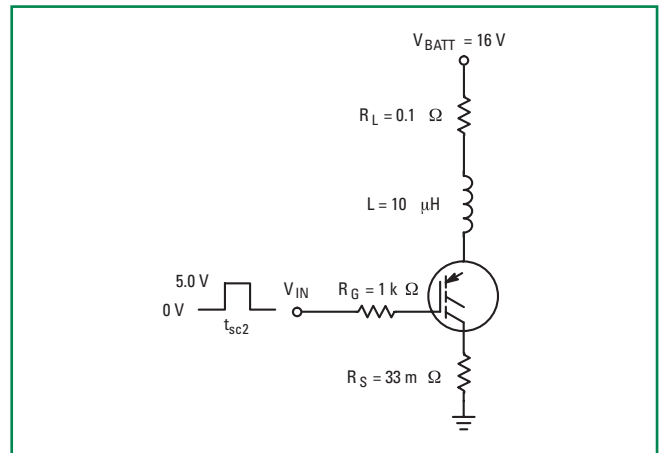
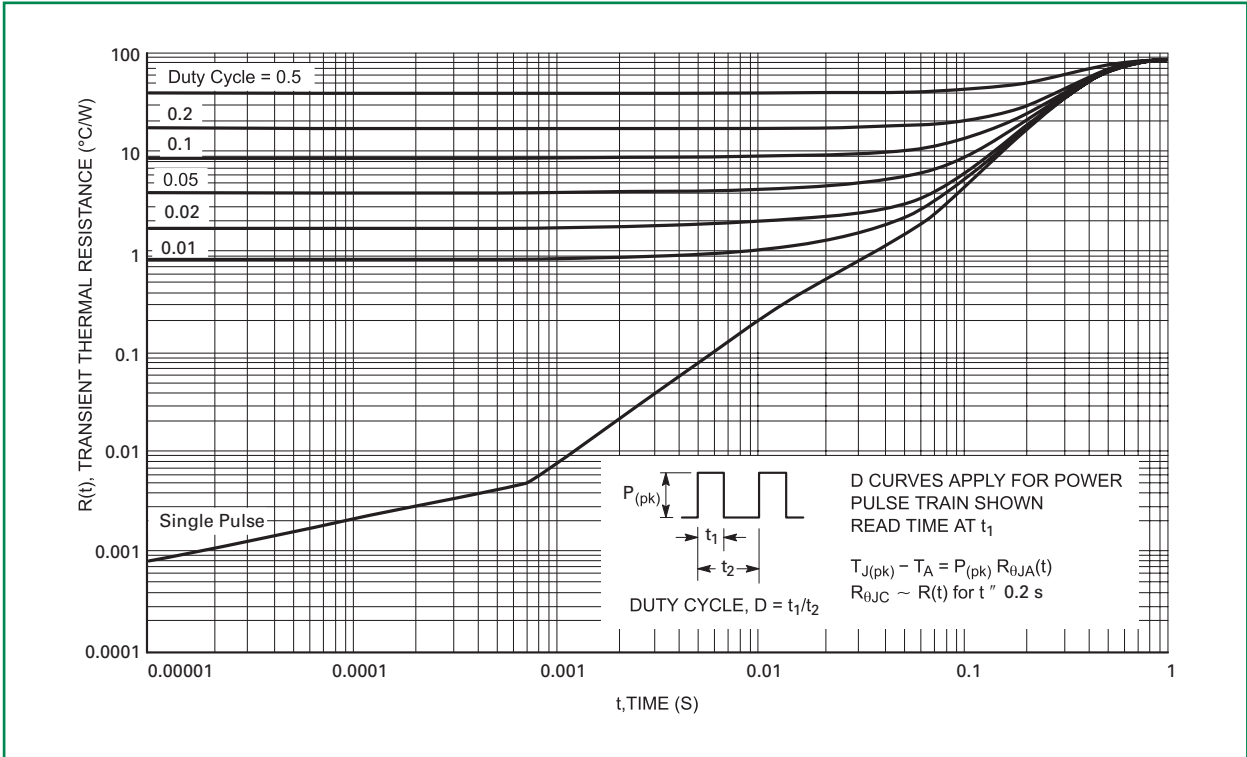
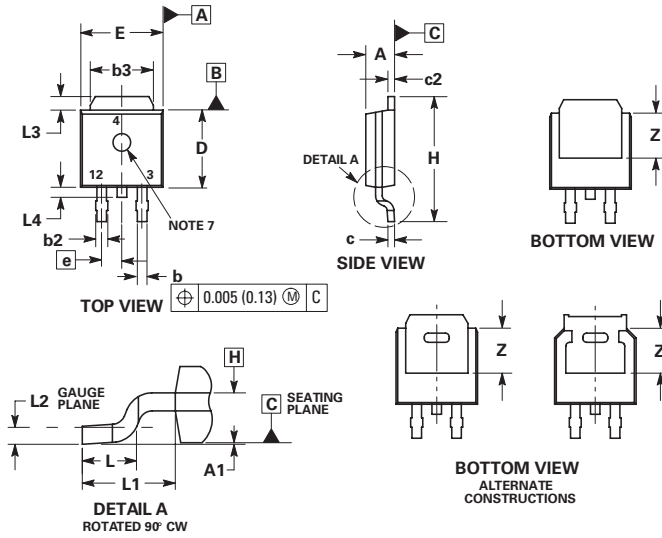

Figure 19. Transient Thermal Resistance (Non-normalized Junction-to-Ambient mounted on minimum pad area)



Dimensions



Dim	Inches		Millimeters	
	Min	Max	Min	Max
A	0.086	0.094	2.18	2.38
A1	0.000	0.005	0.00	0.13
b	0.025	0.035	0.63	0.89
b2	0.028	0.045	0.72	1.14
b3	0.180	0.215	4.57	5.46
c	0.018	0.024	0.46	0.61
c2	0.018	0.024	0.46	0.61
D	0.235	0.245	5.97	6.22
E	0.250	0.265	6.35	6.73
e	0.090 BSC		2.29 BSC	
H	0.370	0.410	9.40	10.41
L	0.055	0.070	1.40	1.78
L1	0.114 REF		2.90 REF	
L2	0.020 BSC		0.51 BSC	
L3	0.035	0.050	0.89	1.27
L4	---	0.040	---	1.01
Z	0.155	---	3.93	---

NOTES:

1. DIMENSIONING AND TOLERANCING PER ASME Y14.5M, 1994.
2. CONTROLLING DIMENSION: INCH.
3. THERMAL PAD CONTOUR OPTIONAL WITHIN DIMENSIONS b3, L3 and Z.
4. DIMENSIONS D AND E DO NOT INCLUDE MOLD FLASH, PROTRUSIONS, OR BURRS. MOLD FLASH, PROTRUSIONS, OR GATE BURRS SHALL NOT EXCEED 0.006 INCHES PER SIDE.
5. DIMENSIONS D AND E ARE DETERMINED AT THE OUTERMOST EXTREMES OF THE PLASTIC BODY.
6. DATUMS A AND B ARE DETERMINED AT DATUM PLANE H.
7. OPTIONAL MOLD FEATURE

Soldering Footprint

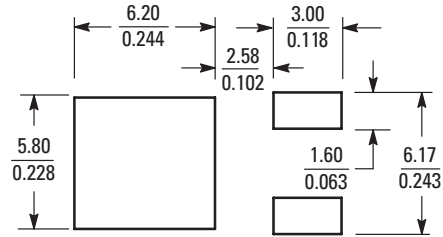

SCALE 3:1 (mm/inches)

Part Marking System

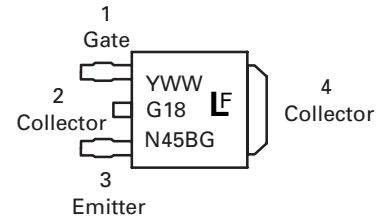

G18N45BG = Device Code

Y= Year
WW = Work Week
G = Pb-Free Device

ORDERING INFORMATION

Device	Package	Shipping†
NGD18N45CLBT4G	DPAK (Pb-Free)	2,500 / Tape & Reel

Disclaimer Notice - Information furnished is believed to be accurate and reliable. However, users should independently evaluate the suitability of and test each product selected for their own applications. Littelfuse products are not designed for, and may not be used in, all applications. Read complete Disclaimer Notice at: www.littelfuse.com/disclaimer-electronics.

Looking for pricing, stock, or lifecycle information?

Click below to explore more details on WIN SOURCE:

 [View NGD18N45CLBT4G on WIN SOURCE](#)

 [Littelfuse Inc. Information](#)

Optimize Your Supply Chain with WIN SOURCE Solutions

-  Global Sourcing Solution
-  Obsolete Management
-  Cost Control Management
-  Shortage Management
-  Alternative Solution
-  Excess Inventory Management