



# THE DATASHEET OF NB6L72MMNG



# 2.5 V / 3.3 V Differential 2 X 2 Crosspoint Switch with CML Outputs

Multi-Level Inputs w/ Internal Termination

## NB6L72M

### Description

The NB6L72M is a clock or data high-bandwidth fully differential 2 x 2 Crosspoint Switch with internal source termination and CML output structure, optimized for low skew and minimal jitter. The differential inputs incorporate internal 50 Ω termination resistors and will accept LVPECL, CML, LVDS, LVCMOS, or LVTTTL logic levels. The SELECT inputs are single-ended and can be driven with LVCMOS/LVTTTL.

The 16 mA differential CML outputs provide matching internal 50 Ω terminations and 400 mV output swings when externally terminated with a 50 Ω resistor to V<sub>CC</sub>.

The device is offered in a small 3 mm x 3 mm 16-pin QFN package.

The NB6L72M is a member of the ECLinPS MAX™ family of high performance clock and data management products.

### Features

- Input Clock Frequency > 3.0 GHz
- Input Data Rate > 3 Gb/s
- 360 ps Typical Propagation Delay
- 65 ps Typical Rise and Fall Times
- Differential CML Outputs, 380 mV peak-to-peak, typical
- Operating Range: V<sub>CC</sub> = 2.375 V to 3.63 V with GND = 0 V
- Internal Input and Output Termination Resistors, 50 Ω
- Functionally Compatible with Existing 2.5 V / 3.3 V LVEL, LVEP, EP, and SG Devices
- -40°C to +85°C Ambient Operating Temperature
- These are Pb-Free Devices

### MARKING DIAGRAM\*

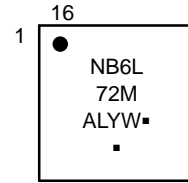

- A = Assembly Location
  - L = Wafer Lot
  - Y = Year
  - W = Work Week
  - = Pb-Free Package
- (Note: Microdot may be in either location)

\*For additional marking information, refer to Application Note AND8002/D.

### ORDERING INFORMATION

See detailed ordering and shipping information in the package dimensions section on page 9 of this data sheet.

# NB6L72M

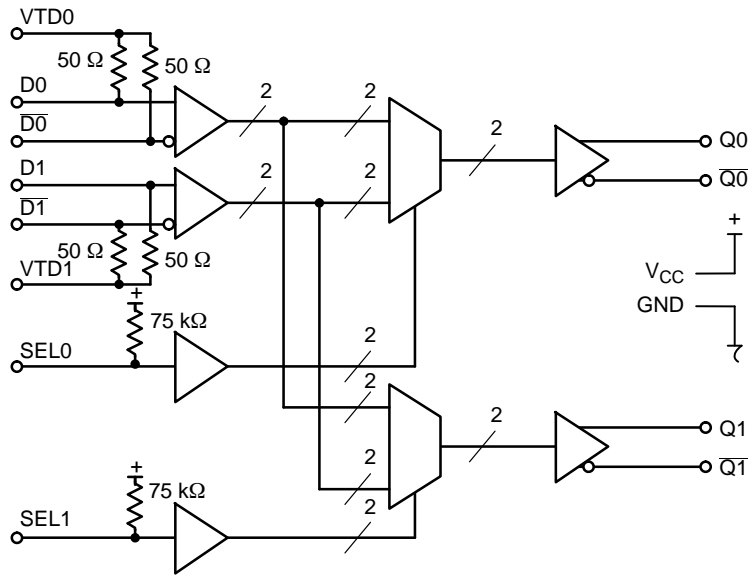

Figure 1. Logic/Block Diagram

# NB6L72M

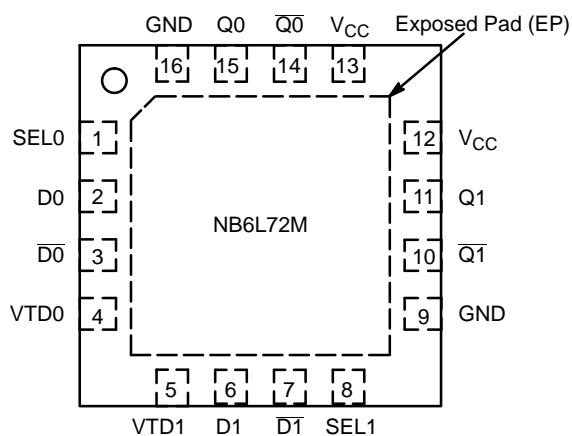

Figure 2. Pin Configuration (Top View)

Table 1. INPUT/OUTPUT SELECT TRUTH TABLE

SEL0*	SEL1*	Q0	Q1
L	L	D0	D0
H	L	D1	D0
L	H	D0	D1
H	H	D1	D1

\*Defaults HIGH when left open

Table 2. PIN DESCRIPTION

Pin	Name	I/O	Description
1	SEL0	LVTTTL,LVCMOS Input	Select Logic Input control that selects D0 or D1 to output Q0. See Table 1, Select Input Function Table. Pin defaults HIGH when left open
2	D0	LVPECL, CML, LVDS, LVTTTL, LVCMOS, Input	Noninverted Differential Input. Note 1
3	D0	LVPECL, CML, LVDS, LVTTTL, LVCMOS, Input	Inverted Differential Input. Note 1
4	VTD0	-	Internal 50 Ω Termination Pin. Note 1.
5	VTD1	-	Internal 50 Ω termination pin. Note 1.
6	D1	LVPECL, CML, LVDS, LVTTTL, LVCMOS, Input	Noninverted Differential Input. Note 1.
7	D1	LVPECL, CML, LVDS, LVTTTL, LVCMOS, Input	Inverted Differential Input. Note 1
8	SEL1	LVTTTL,LVCMOS Input	Select Logic Input control that selects D0 or D1 to output Q1. See Table 1, Select Input Function Table. Pin defaults HIGH when left open
9	GND	-	Negative Supply Voltage
10	Q1	CML Output	Inverted Differential Output. Typically Terminated with 50 Ω Resistor to V <sub>CC</sub> .
11	Q1	CML Output	Noninverted Differential Output. Typically Terminated with 50 Ω Resistor to V <sub>CC</sub> .
12	V <sub>CC</sub>	-	Positive Supply Voltage
13	V <sub>CC</sub>	-	Positive Supply Voltage
14	Q0	CML Output	Inverted Differential Reset Input. Typically Terminated with 50 Ω Resistor to V <sub>CC</sub> .
15	Q0	CML Output	Noninverted Differential Reset Input. Typically Terminated with 50 Ω Resistor to V <sub>CC</sub> .
16	GND	-	Negative Supply Voltage
-	EP	-	The Exposed Pad (EP) on the QFN-16 package bottom is thermally connected to the die for improved heat transfer out of package. The exposed pad must be attached to a heat-sinking conduit. The pad is not electrically connected to the die, but is recommended to be electrically and thermally connected to GND on the PC board.

1. In the differential configuration when the input termination pin (VTDn) are connected to a common termination voltage or left open, and if no signal is applied on Dn/Dn input, then the device will be susceptible to self-oscillation.
2. All V<sub>CC</sub> and GND pins must be externally connected to a power supply for proper operation.

# NB6L72M

**Table 3. ATTRIBUTES**

Characteristics		Value
Interval Input Pulldown Resistor		75 kΩ
ESD Protection	Human Body Model Machine Model	> 2 kV > 200V
Moisture Sensitivity	16-QFN	Level 1
Flammability Rating	Oxygen Index: 28 to 34	UL 94 V-0 @ 0.125 in
Transistor Count		
Meets or exceeds JEDEC Spec EIA/JESD78 IC Latchup Test		

For additional information, see Application Note AND8003/D.

**Table 4. MAXIMUM RATINGS**

Symbol	Parameter	Condition 1	Condition 2	Rating	Unit
V <sub>CC</sub>	Positive Power Supply	GND = 0 V		4.0	V
V <sub>IO</sub>	Positive Input/Output Voltage	GND = 0 V	-0.5 ≤ V <sub>IO</sub> ≤ V <sub>CC</sub> + 0.5	4.5	V
V <sub>INPP</sub>	Differential Input Voltage  D - $\bar{D}$			V <sub>CC</sub> - GND	V
I <sub>IN</sub>	Input Current Through R <sub>T</sub> (50 Ω Resistor)	Static Surge		45 80	mA mA
T <sub>A</sub>	Operating Temperature Range	QFN-16		-40 to +85	°C
T <sub>stg</sub>	Storage Temperature Range			-65 to +150	°C
θ <sub>JA</sub>	Thermal Resistance (Junction-to-Ambient) (Note 3)	0 lfpm 500 lfpm	QFN-16 QFN-16	42 35	°C/W °C/W
θ <sub>JC</sub>	Thermal Resistance (Junction-to-Case)	(Note 3)	QFN-16	4	°C/W
T <sub>sol</sub>	Wave Solder Pb-Free			265	°C

Stresses exceeding those listed in the Maximum Ratings table may damage the device. If any of these limits are exceeded, device functionality should not be assumed, damage may occur and reliability may be affected.

3. JEDEC standard multilayer board – 2S2P (2 signal, 2 power) with 8 filled thermal vias under exposed pad.

# NB6L72M

**Table 5. DC CHARACTERISTICS, Multi-Level Inputs**  $V_{CC} = 2.375\text{ V to }3.63\text{ V}$ ,  $GND = 0\text{ V}$ ,  $T_A = -40^\circ\text{C to }+85^\circ\text{C}$

Symbol	Characteristic	Min	Typ	Max	Unit
<b>POWER SUPPLY CURRENT</b>					
$I_{CC}$	Power Supply Current (Inputs and Outputs Open)	60	80	105	mA
<b>CML OUTPUTS (Notes 5 and 6)</b>					
$V_{OH}$	Output HIGH Voltage $V_{CC} = 3.3\text{ V}$ $V_{CC} = 2.5\text{ V}$	$V_{CC} - 40$ 3260 2460	$V_{CC} - 10$ 3290 2490	$V_{CC}$ 3300 2500	mV
$V_{OL}$	Output LOW Voltage $V_{CC} = 3.3\text{ V}$ $V_{CC} = 2.5\text{ V}$	$V_{CC} - 500$ 2800 2000	$V_{CC} - 400$ 2900 2100	$V_{CC} - 300$ 3000 2200	mV
<b>DIFFERENTIAL INPUT DRIVEN SINGLE-ENDED (see Figures 6 and 8)</b>					
$V_{th}$	Input Threshold Reference Voltage Range (Note 7)	1050		$V_{CC} - 150$	mV
$V_{IH}$	Single-Ended Input HIGH Voltage	$V_{th} + 150$		$V_{CC}$	mV
$V_{IL}$	Single-Ended Input LOW Voltage	GND		$V_{th} - 150$	mV
$V_{ISE}$	Single-Ended Input Voltage Amplitude ( $V_{IH} - V_{IL}$ )	300		$V_{CC} - V_{EE}$	mV
<b>DIFFERENTIAL INPUTS DRIVEN DIFFERENTIALLY (see Figures 7 and 9) (Note 8)</b>					
$V_{IHD}$	Differential Input HIGH Voltage	1200		$V_{CC}$	mV
$V_{ILD}$	Differential Input LOW Voltage	GND		$V_{CC} - 150$	mV
$V_{ID}$	Differential Input Voltage Swing ( $D_n, \overline{D}_n$ ) ( $V_{IHD} - V_{ILD}$ ) (Note 15)	150		$V_{CC} - V_{EE}$	mV
$V_{CMR}$	Input Common Mode Range (Differential Configuration) (Note 9)	950		$V_{CC} - 75$	mV
$I_{IH}$	Input HIGH Current $D_n/\overline{D}_n$ , ( $V_{TDn}/\overline{V_{TDn}}$ Open)	-150		+150	$\mu\text{A}$
$I_{IL}$	Input LOW Current $D_n/\overline{D}_n$ , ( $V_{TDn}/\overline{V_{TDn}}$ Open)	-150		+150	$\mu\text{A}$
<b>SINGLE-ENDED LVCMOS/LVTTL CONTROL INPUTS</b>					
$V_{IH}$	Single-Ended Input HIGH Voltage	2000		$V_{CC}$	mV
$V_{IL}$	Single-Ended Input LOW Voltage	GND		800	mV
$I_{IH}$	Input HIGH Current	-150		+150	$\mu\text{A}$
$I_{IL}$	Input LOW Current	-150		+150	$\mu\text{A}$
<b>TERMINATION RESISTORS</b>					
$R_{TIN}$	Internal Input Termination Resistor	40	50	60	$\Omega$
$R_{TOUT}$	Internal Output Termination Resistor	40	50	60	$\Omega$

NOTE: Device will meet the specifications after thermal equilibrium has been established when mounted in a test socket or printed circuit board with maintained transverse airflow greater than 500 lfm.

- CML outputs loaded with  $50\ \Omega$  to  $V_{CC}$  for proper operation.
- Input and output parameters vary 1:1 with  $V_{CC}$ .
- $V_{th}$ ,  $V_{IH}$ ,  $V_{IL}$ , and  $V_{ISE}$  parameters must be complied with simultaneously.
- $V_{th}$  is applied to the complementary input when operating in single-ended mode.
- $V_{IHD}$ ,  $V_{ILD}$ ,  $V_{ID}$  and  $V_{CMR}$  parameters must be complied with simultaneously.
- $V_{CMR}$  minimum varies 1:1 with GND,  $V_{CMR}$  max varies 1:1 with  $V_{CC}$ . The  $V_{CMR}$  range is referenced to the most positive side of the differential input signal.

## NB6L72M

**Table 6. AC CHARACTERISTICS**  $V_{CC} = 2.375\text{ V to }3.63\text{ V}$ ,  $GND = 0\text{ V}$ , or  $V_{CC} = 0\text{ V}$ ,  $GND = -2.375\text{ V to }-3.63\text{ V}$ ,  
 $T_A = -40^\circ\text{C to }+85^\circ\text{C}$ ; (Note 10)

Symbol	Characteristic	Min	Typ	Max	Unit	
$V_{OUTPP}$	Output Voltage Amplitude (@ $V_{INPPmin}$ ) (Note 15) (See Figure 15)	$f_{in} \leq 3\text{ GHz}$	250	380		mV
$f_{DATA}$	Maximum Operating Data Rate	3				Gb/s
$t_{PLH}$ , $t_{PHL}$	Propagation Delay (@0.5GHz)	Dn to Qn SELn to Qn	230	360	480	ps
$t_{SKEW}$	Duty Cycle Skew (Note 11) Within Device Skew Device to Device Skew (Note 12)		6.0	20 25 85		ps
$t_{DC}$	Output Clock Duty Cycle (Reference Duty Cycle = 50%)	$f_{in} \leq 3.0\text{ GHz}$	40	50	60	%
$t_{JITTER}$	RMS Random Clock Jitter (Note 13) Peak-to-Peak Data Dependent Jitter (Note 14)	$f_{in} \leq 3.0\text{ GHz}$ $f_{DATA} = 2.5\text{ Gb/s}$ $f_{DATA} = 3.0\text{ Gb/s}$		0.2 5.0 8.0	0.5 15 25	ps
$V_{INPP}$	Input Voltage Swing/Sensitivity (Differential Configuration) (Note 15)		150		2800	mV
$t_r$ , $t_f$	Output Rise/Fall Times @ 0.5 GHz, (20% – 80%),	Q, $\bar{Q}$		65	120	ps

NOTE: Device will meet the specifications after thermal equilibrium has been established when mounted in a test socket or printed circuit board with maintained transverse airflow greater than 500 lpm.

10. Measured by forcing  $V_{INPP}$  (minimum) from a 50% duty cycle clock source. All loading with an external  $R_L = 50\ \Omega$  to  $V_{CC}$ . Input edge rates 40 ps (20% – 80%).
11. Duty cycle skew is measured between differential outputs using the deviations of the sum of  $T_{pw-}$  and  $T_{pw+}$  @ 0.5GHz.
12. Device to device skew is measured between outputs under identical transition @ 0.5 GHz.
13. Additive RMS jitter with 50% duty cycle clock signal.
14. Additive peak-to-peak data dependent jitter with input NRZ data at PRBS23.
15. Input and output voltage swing is a single-ended measurement operating in differential mode.

# NB6L72M

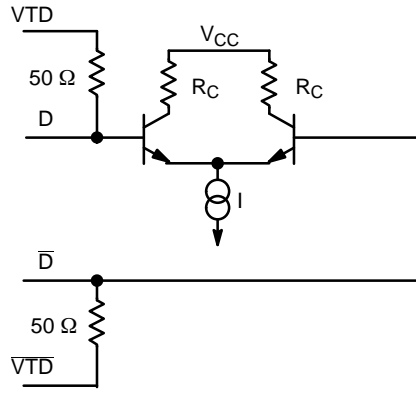

Figure 3. Input Structure

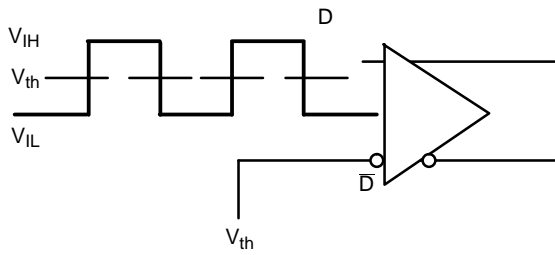

Figure 4. Differential Input Driven Single-Ended

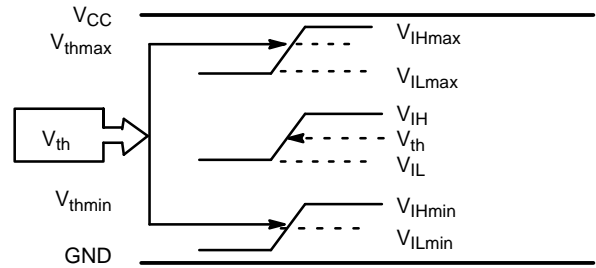

Figure 5.  $V_{th}$  Diagram

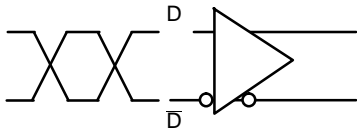

Figure 6. Differential Inputs Driven Differentially

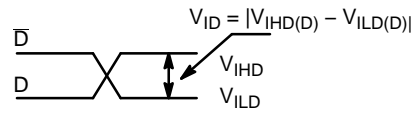

Figure 7. Differential Inputs Driven Differentially

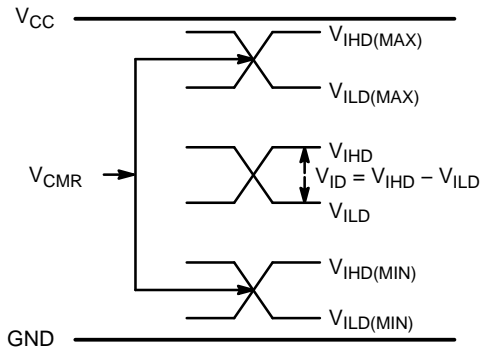

Figure 8.  $V_{CM}$  Diagram

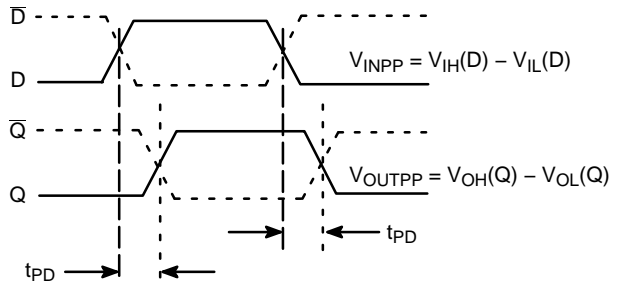

Figure 9. AC Reference Measurement

# NB6L72M

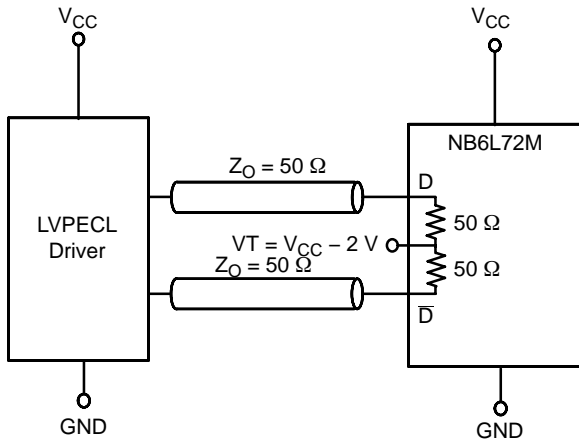

Figure 10. LVPECL Interface

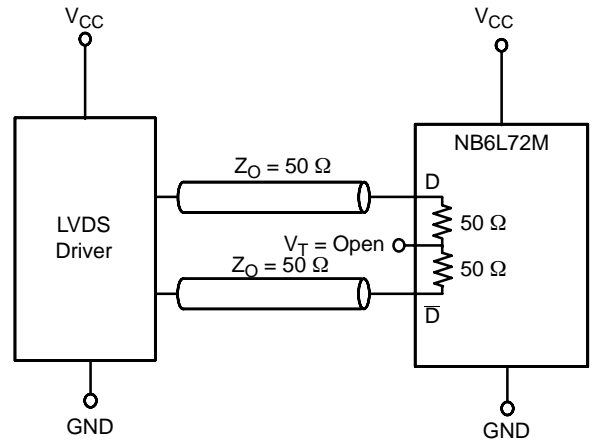

Figure 11. LVDS Interface

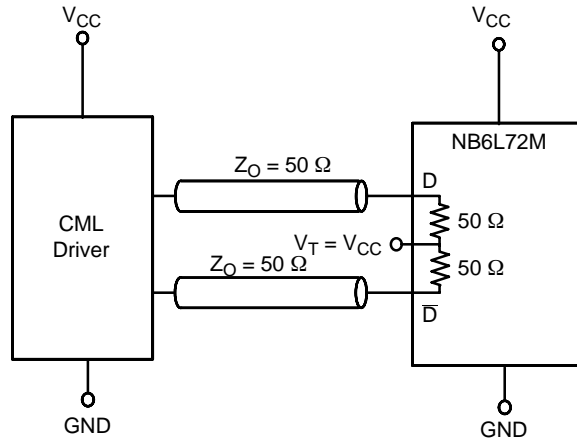

Figure 12. Standard 50 Ω Load CML Interface

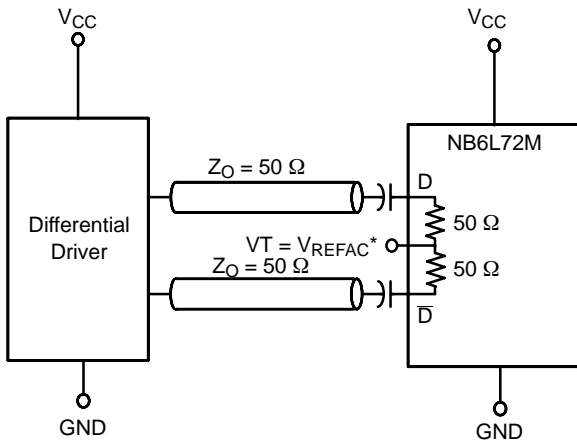

Figure 13. Capacitor-Coupled Differential Interface (V<sub>T</sub> Connected to V<sub>REFAC</sub>)

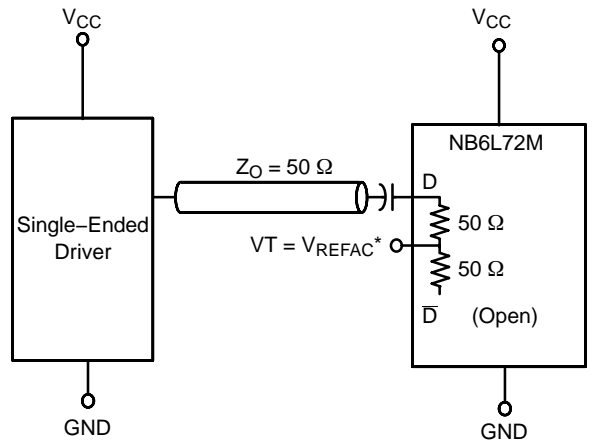

Figure 14. Capacitor-Coupled Single-Ended Interface (V<sub>T</sub> Connected to V<sub>REFAC</sub>)

\*V<sub>REFAC</sub> bypassed to ground with a 0.01 μF capacitor

# NB6L72M

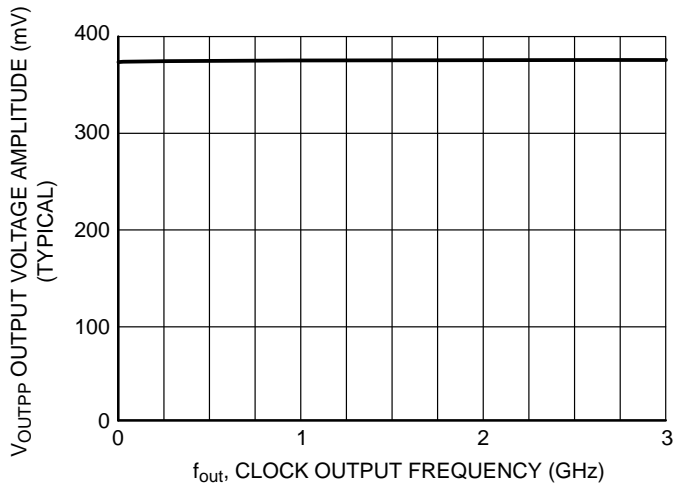

Figure 15. Output Voltage Amplitude ( $V_{OUTPP}$ ) versus Output Frequency at Ambient Temperature (Typical)

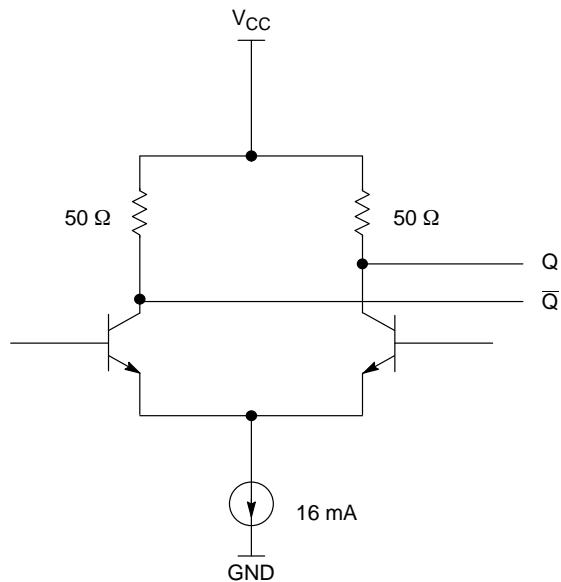

Figure 16. CML Output Structure

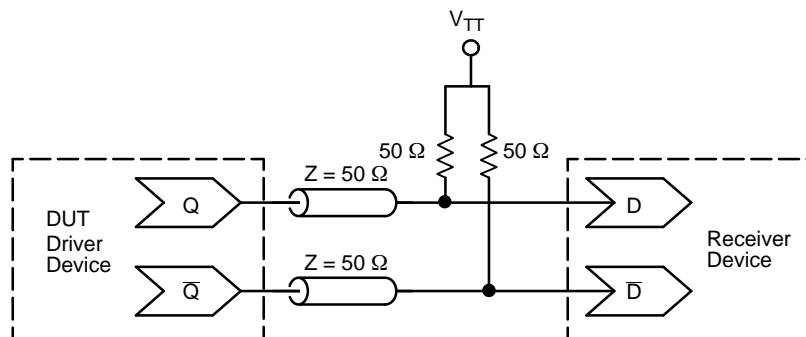

Figure 17. Typical CML Termination for Output Driver and Device Evaluation

## ORDERING INFORMATION

Device	Package	Shipping†
NB6L72MMNG	QFN-16 (Pb-free)	123 Units / Rail
NB6L72MMNR2G	QFN-16 (Pb-free)	3000 / Tape & Reel

†For information on tape and reel specifications, including part orientation and tape sizes, please refer to our Tape and Reel Packaging Specifications Brochure, BRD8011/D.

# MECHANICAL CASE OUTLINE PACKAGE DIMENSIONS



SCALE 2:1

**QFN16 3x3, 0.5P**  
CASE 485G  
ISSUE G

DATE 08 OCT 2021

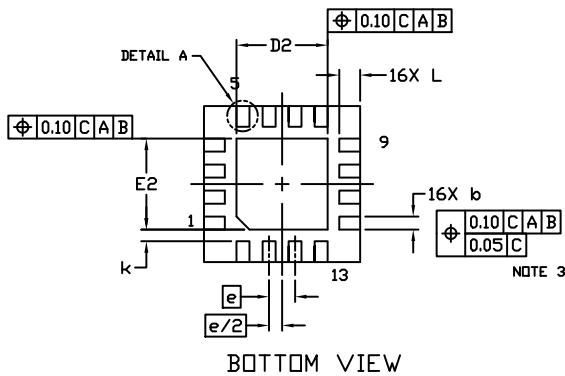
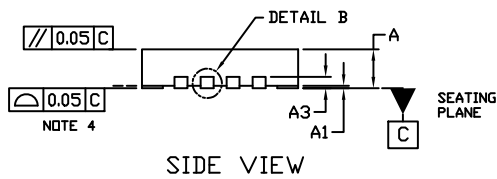
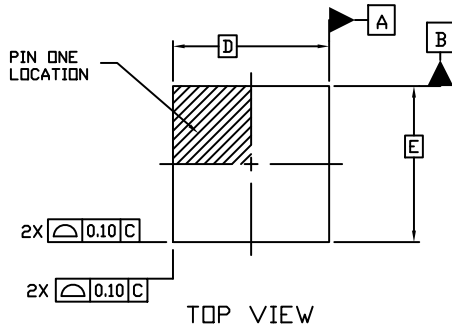

**NOTES:**

1. DIMENSIONING AND TOLERANCING PER ASME Y14.5M, 1994.
2. CONTROLLING DIMENSION: MILLIMETERS
3. DIMENSION b APPLIES TO PLATED TERMINAL AND IS MEASURED BETWEEN 0.15 AND 0.30 MM FROM THE TERMINAL TIP.
4. COPLANARITY APPLIES TO THE EXPOSED PAD AS WELL AS THE TERMINALS.

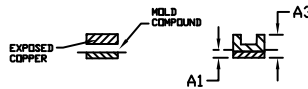

DETAIL B  
ALTERNATE  
CONSTRUCTIONS

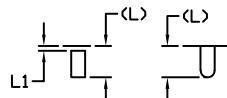

DETAIL A  
ALTERNATE TERMINAL  
CONSTRUCTIONS

DIM	MILLIMETERS		
	MIN.	NDM.	MAX.
A	0.80	0.90	1.00
A1	0.00	0.03	0.05
A3	0.20 REF		
b	0.18	0.24	0.30
D	3.00 BSC		
D2	1.65	1.75	1.85
E	3.00 BSC		
E2	1.65	1.75	1.85
e	0.50 BSC		
k	0.18 TYP		
L	0.30	0.40	0.50
L1	0.00	0.08	0.15

**MOUNTING FOOTPRINT**

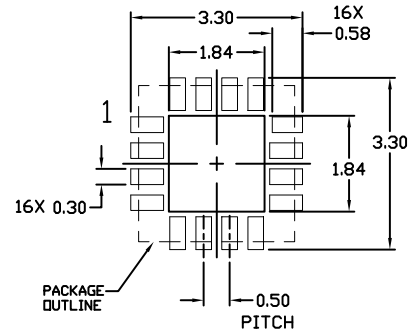

**GENERIC MARKING DIAGRAM\***

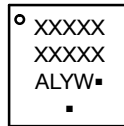

- XXXXX = Specific Device Code
- A = Assembly Location
- L = Wafer Lot
- Y = Year
- W = Work Week
- = Pb-Free Package

(Note: Microdot may be in either location)

\*This information is generic. Please refer to device data sheet for actual part marking. Pb-Free indicator, "G" or microdot "▪", may or may not be present. Some products may not follow the Generic Marking.

<b>DOCUMENT NUMBER:</b>	<b>98AON04795D</b>	Electronic versions are uncontrolled except when accessed directly from the Document Repository. Printed versions are uncontrolled except when stamped "CONTROLLED COPY" in red.
<b>DESCRIPTION:</b>	<b>QFN16 3X3, 0.5P</b>	<b>PAGE 1 OF 1</b>

onsemi and ONSEMI are trademarks of Semiconductor Components Industries, LLC dba onsemi or its subsidiaries in the United States and/or other countries. onsemi reserves the right to make changes without further notice to any products herein. onsemi makes no warranty, representation or guarantee regarding the suitability of its products for any particular purpose, nor does onsemi assume any liability arising out of the application or use of any product or circuit, and specifically disclaims any and all liability, including without limitation special, consequential or incidental damages. onsemi does not convey any license under its patent rights nor the rights of others.

**onsemi**, **Onsemi**, and other names, marks, and brands are registered and/or common law trademarks of Semiconductor Components Industries, LLC dba "**onsemi**" or its affiliates and/or subsidiaries in the United States and/or other countries. **onsemi** owns the rights to a number of patents, trademarks, copyrights, trade secrets, and other intellectual property. A listing of **onsemi**'s product/patent coverage may be accessed at [www.onsemi.com/site/pdf/Patent-Marking.pdf](http://www.onsemi.com/site/pdf/Patent-Marking.pdf). **onsemi** reserves the right to make changes at any time to any products or information herein, without notice. The information herein is provided "as-is" and **onsemi** makes no warranty, representation or guarantee regarding the accuracy of the information, product features, availability, functionality, or suitability of its products for any particular purpose, nor does **onsemi** assume any liability arising out of the application or use of any product or circuit, and specifically disclaims any and all liability, including without limitation special, consequential or incidental damages. Buyer is responsible for its products and applications using **onsemi** products, including compliance with all laws, regulations and safety requirements or standards, regardless of any support or applications information provided by **onsemi**. "Typical" parameters which may be provided in **onsemi** data sheets and/or specifications can and do vary in different applications and actual performance may vary over time. All operating parameters, including "Typicals" must be validated for each customer application by customer's technical experts. **onsemi** does not convey any license under any of its intellectual property rights nor the rights of others. **onsemi** products are not designed, intended, or authorized for use as a critical component in life support systems or any FDA Class 3 medical devices or medical devices with a same or similar classification in a foreign jurisdiction or any devices intended for implantation in the human body. Should Buyer purchase or use **onsemi** products for any such unintended or unauthorized application, Buyer shall indemnify and hold **onsemi** and its officers, employees, subsidiaries, affiliates, and distributors harmless against all claims, costs, damages, and expenses, and reasonable attorney fees arising out of, directly or indirectly, any claim of personal injury or death associated with such unintended or unauthorized use, even if such claim alleges that **onsemi** was negligent regarding the design or manufacture of the part. **onsemi** is an Equal Opportunity/Affirmative Action Employer. This literature is subject to all applicable copyright laws and is not for resale in any manner.

## ADDITIONAL INFORMATION

### TECHNICAL PUBLICATIONS:

Technical Library: [www.onsemi.com/design/resources/technical-documentation](http://www.onsemi.com/design/resources/technical-documentation)  
onsemi Website: [www.onsemi.com](http://www.onsemi.com)

### ONLINE SUPPORT: [www.onsemi.com/support](http://www.onsemi.com/support)

For additional information, please contact your local Sales Representative at [www.onsemi.com/support/sales](http://www.onsemi.com/support/sales)

## Looking for pricing, stock, or lifecycle information?

Click below to explore more details on WIN SOURCE:

 [View NB6L72MMNG on WIN SOURCE](#)

 [ON Semiconductor](#) Information

## Optimize Your Supply Chain with WIN SOURCE Solutions

-  Global Sourcing Solution
-  Obsolete Management
-  Cost Control Management
-  Shortage Management
-  Alternative Solution
-  Excess Inventory Management