



**THE DATASHEET OF
NB3L204KMNTXG**



2.5V, 3.3V Differential 1:4 HCSL Fanout Buffer

NB3L204K

MARKING DIAGRAM

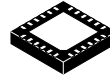

QFN24
4x4
CASE 485DJ

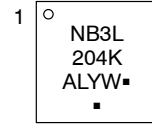

Description

The NB3L204K is a differential 1:4 Clock fanout buffer with High-speed Current Steering Logic (HCSL) outputs. Inputs can directly accept differential LVPECL, LVDS, and HCSL signals. Single-ended LVPECL, HCSL, LVCMOS, or LVTTTL levels are accepted with a proper external V_{th} reference supply per Figures 4 and 6. The input signal will be translated to HCSL and provides four identical copies operating up to 350 MHz.

The NB3L204K is optimized for ultra-low phase noise, propagation delay variation and low output-to-output skew, and is DB400H compliant. As such, system designers can take advantage of the NB3L204K's performance to distribute low skew clocks across the backplane or the motherboard making it ideal for Clock and Data distribution applications such as PCI Express, FBDIMM, Networking, Mobile Computing, Gigabit Ethernet, etc.

Output drive current is set by connecting a 475 Ω resistor from IREF (Pin 14) to GND per Figure 11. Outputs can also interface to LVDS receivers when terminated per Figure 12.

Features

- Maximum Input Clock Frequency > 350 MHz
- 2.5 V $\pm 5\%$ / 3.3 V $\pm 10\%$ Supply Voltage Operation
- 4 HCSL Outputs
- DB400H Compliant
- PCIe Gen 3, Gen 4 Compliant
- Individual OE Control Pin for Each Output
- 100 ps Max Output-to-Output Skew Performance
- 1 ns Typical Propagation Delay
- 500 ps Typical Rise and Fall Times
- 80 fs Maximum Additive RMS Phase Jitter
- -40°C to $+85^{\circ}\text{C}$ Ambient Operating Temperature
- QFN 24-pin Package, 4 mm x 4 mm
- These Devices are Pb-Free and are RoHS Compliant

Typical Applications

- PCI Express
- FBDIMM
- Mobile Computing
- Networking
- Gigabit Ethernet

NB3L204K = Specific Device Code
A = Assembly Location
L = Wafer Lot
Y = Year
W = Work Week
▪ = Pb-Free Package

(Note: Microdot may be in either location)

ORDERING INFORMATION

See detailed ordering and shipping information page 13 of this data sheet.

NB3L204K

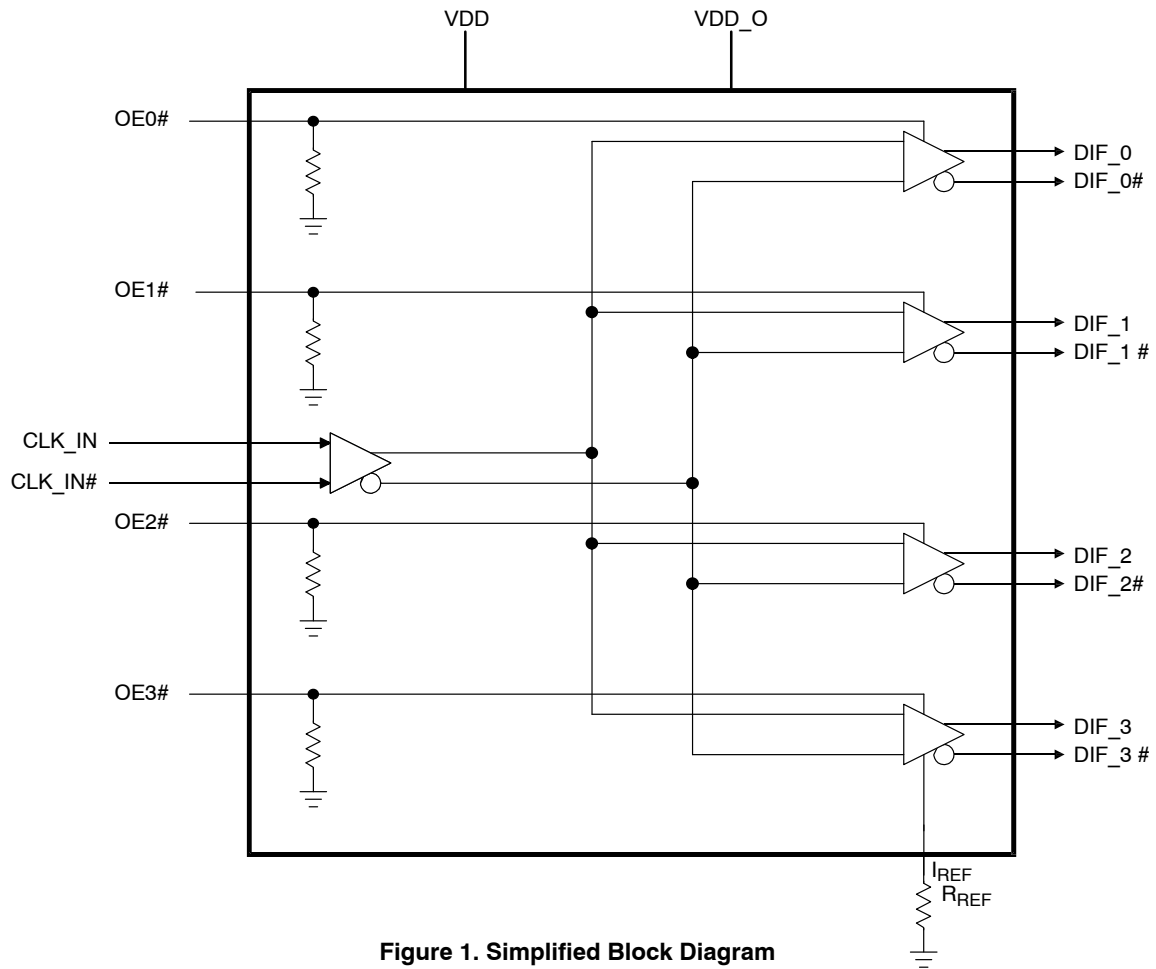

Figure 1. Simplified Block Diagram

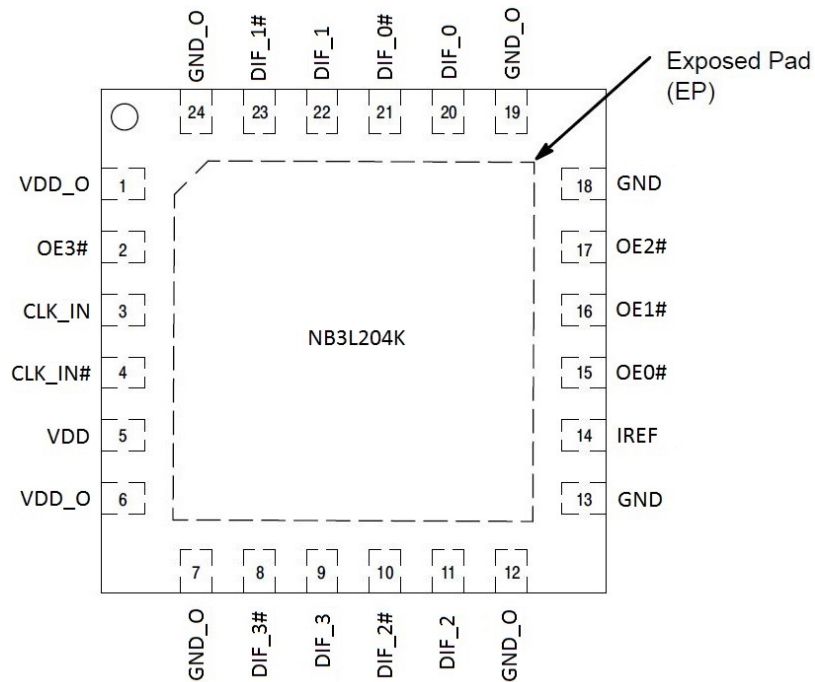

Figure 2. 24-Pin QFN Pinout
(Top View)

NB3L204K

Table 1. PIN DESCRIPTION

Pin Number	Pin Name	I/O	Description
1	VDD_O	Power	Power supply for outputs
2	OE3#	I, SE	LVTTL / LVCMOS active low input for enabling output DIF_3/3#. 0 enables outputs, 1 disables outputs. Internal pull down.
3	CLK_IN	I, DIF	Differential True input
4	CLK_IN#	I, DIF	Differential Complementary input
5	VDD	Power	Core power supply
6	VDD_O	Power	Power supply for outputs
7	GND_O	Power	Ground for outputs
8	DIF_3#	O, DIF	0.7 V Differential Complementary Output
9	DIF_3	O, DIF	0.7 V Differential True Output
10	DIF_2#	O, DIF	0.7 V Differential Complementary Output
11	DIF_2	O, DIF	0.7 V Differential True Output
12	GND_O	Power	Ground for outputs
13	GND	Power	Ground
14	IREF	I	A precision resistor is attached to this pin to set the differential output current. Use $R_{REF} = 475 \Omega$, 1% for 100 Ω trace, with 50 Ω termination. Use $R_{REF} = 412 \Omega$, 1% for 85 Ω trace, with 43 Ω termination.
15	OE0#	I, SE	LVTTL / LVCMOS active low input for enabling output DIF_0/0#. 0 enables outputs, 1 disables outputs. Internal pull down.
16	OE1#	I, SE	LVTTL / LVCMOS active low input for enabling output DIF_1/1#. 0 enables outputs, 1 disables outputs. Internal pull down.
17	OE2#	I, SE	LVTTL / LVCMOS active low input for enabling output DIF_2/2#. 0 enables outputs, 1 disables outputs. Internal pull down.
18	GND	Power	Ground
19	GND_O	Power	Ground for outputs
20	DIF_0	O, DIF	0.7 V Differential True Output
21	DIF_0#	O, DIF	0.7 V Differential Complementary Output
22	DIF_1	O, DIF	0.7 V Differential True Output
23	DIF_1#	O, DIF	0.7 V Differential Complementary Output
24	GND_O	Power	Ground for outputs
EP	Exposed Pad	Thermal	The Exposed Pad (EP) on the QFN24 package bottom is thermally connected to the die for improved heat transfer out of package. The exposed pad must be attached to a heat-sinking conduit. The pad is electrically connected to the die, and must be electrically and thermally connected to GND on the PC board.

NB3L204K

Table 2. ATTRIBUTES

Characteristics		Value
ESD Protection	Human Body Model	> 2000 V
RPD – Pull-down Resistor		50 kΩ
Moisture Sensitivity (Note 1)		Level 1
Flammability Rating	Oxygen Index: 28 to 34	UL 94 V-0 @ 0.125 in
Transistor Count		1344
Meets or exceeds JEDEC Spec EIA/JESD78 IC Latchup Test		

1. For additional information, see Application Note AND8003/D.

Table 3. ABSOLUTE MAXIMUM RATINGS

Symbol	Parameter		Min	Max	Unit
V _{DD}	Core Supply Voltage		–	4.6	V
V _{DD_O}	I/O Supply Voltage		–	4.6	V
V _{IH}	Input High Voltage (Note 2)		–	4.6	V
V _{IL}	Input Low Voltage		–0.5	–	V
I _{OUT}	Maximum Output Current		–	24	mA
T _A	Operating Temperature Range			–40 to +85	°C
T _{stg}	Storage Temperature Range			–65 to +150	°C
θ _{JA}	Thermal Resistance (Junction-to-Ambient) (Note 3)	0 lfpm 500 lfpm		37 32	°C/W
θ _{JC}	Thermal Resistance (Junction-to-Case) (Note 3)			11	°C/W
T _{sol}	Wave Solder			265	°C

Stresses exceeding those listed in the Maximum Ratings table may damage the device. If any of these limits are exceeded, device functionality should not be assumed, damage may occur and reliability may be affected.

2. Maximum V_{IH} is not to exceed maximum V_{DD}.

3. JEDEC standard multilayer board – 2S2P (2 signal, 2 power) with 8 filled thermal vias under exposed pad.

NB3L204K

Table 4. DC CHARACTERISTICS $V_{DD} = V_{DD_O} = 3.3\text{ V} \pm 10\%$ or $2.5\text{ V} \pm 5\%$, $T_A = -40^\circ\text{C}$ to 85°C

Symbol	Characteristics	Min	Typ	Max	Unit
--------	-----------------	-----	-----	-----	------

POWER SUPPLY CURRENT

V_{DD}	Core Power Supply Voltage $V_{DD} = 3.3\text{ V} \pm 10\%$ $V_{DD} = 2.5\text{ V} \pm 5\%$	2.970 2.375	3.3 2.5	3.630 2.625	V
V_{DD_O}	Output Power Supply Voltage $V_{DD_O} = 3.3\text{ V} \pm 10\%$ $V_{DD_O} = 2.5\text{ V} \pm 5\%$	2.970 2.375	3.3 2.5	3.630 2.625	V
$I_{DD} + I_{DD_O}$	Total Power Supply Current (all outputs active @ 350 MHz, $R_{REF} = 412\ \Omega$, $R_L = 43\ \Omega$)		110	150	mA
I_{stdby}	Standby Current, all OE pins de-asserted with inputs @ 350 MHz		50	65	mA
I_{incr}	Incremental output current for additional output; One OE Enabled		15	23	mA
$I_{stdby} + I_{incr}$	Standby Current plus incremental current for one additional differential output; One OE Enabled @ 350 MHz		65	88	mA

HCSL OUTPUTS (Notes 4, 5)

V_{OH}	Output HIGH Voltage	660		850	mV
V_{OL}	Output LOW Voltage	-150			mV
V_{OUT}	Output Swing (Single-Ended) Output Swing (Differential)	400 800	750 1500		mV

DIFFERENTIAL INPUT DRIVEN SINGLE-ENDED (Note 6) (Figures 4 and 6)

V_{IH}	CLK_IN/CLK_IN# Single-ended Input HIGH Voltage	0.5		V_{DD}	V
V_{IL}	CLK_IN/CLK_IN# Single-ended Input LOW Voltage	GND		$V_{IH} - 0.3$	V
V_{th}	Input Threshold Reference Voltage Range (Note 7)	0.25		$V_{DD} - 1.0$	V
V_{ISE}	Single-ended Input Voltage ($V_{IH} - V_{IL}$)	0.5		V_{DD}	V

DIFFERENTIAL INPUTS DRIVEN DIFFERENTIALLY (Note 8) (Figures 5 and 7)

V_{IHD}	Differential Input HIGH Voltage	0.5		$V_{DD} - 0.85$	V
V_{ILD}	Differential Input LOW Voltage	0		$V_{IHD} - 0.25$	V
V_{ID}	Differential Input Voltage ($V_{IHD} - V_{ILD}$)	0.25		1.3	V
V_{IHCMR}	Input Common Mode Range (Differential Configuration) (Note 9) (Figure 8)	0.5		$V_{DD} - 0.85$	V
I_{IL}	Input Leakage Current $0 < V_{IN} < V_{DD}$ (Note 10)	-5		5	μA

LVTTTL / LVCMOS INPUTS (OEx#)

V_{IH}	Input HIGH Voltage	2.0		$V_{DD} + 0.3$	V
V_{IL}	Input LOW Voltage	-0.3		0.8	V
I_{IL}	Input LOW Current ($V_{IN} = \text{GND}$)	-10		+10	μA
I_{IH}	Input HIGH Current ($V_{IN} = V_{DD}$)			100	μA

Product parametric performance is indicated in the Electrical Characteristics for the listed test conditions, unless otherwise noted. Product performance may not be indicated by the Electrical Characteristics if operated under different conditions.

- Test configuration is $R_S = 33.2\ \Omega$, $R_L = 49.9$, $C_L = 2\ \text{pF}$, $R_{REF} = 475\ \Omega$.
- Measurement taken from Single-Ended waveform unless specified otherwise.
- V_{IH} , V_{IL} , V_{th} and V_{ISE} parameters must be complied with simultaneously.
- V_{th} is applied to the complementary input when operating in single-ended mode.
- V_{IHD} , V_{ILD} , V_{ID} and V_{CMR} parameters must be complied with simultaneously.
- The common mode voltage is defined as V_{IH} .
- Does not include inputs with pulldown resistors.

NB3L204K

Table 5. AC TIMING CHARACTERISTICS $V_{DD} = V_{DD_O} = 3.3\text{ V} \pm 10\%$ or $2.5\text{ V} \pm 5\%$, $T_A = -40^\circ\text{C}$ to 85°C (Note 15)

Symbol	Characteristics	Min	Typ	Max	Unit
F_{\max}	Maximum Input Frequency	350			MHz
$T_{\text{rise}}/T_{\text{fall}}$	Rise Time / Fall Time (Notes 13, 17 and 33) (Figure 13)	175	500	700	ps
Output Slew Rate	Output Slew Rate (Notes 13 and 17)	0.5		2.0	V/ns
$\Delta T_{\text{rise}}/\Delta T_{\text{fall}}$	Rise/Fall Time Variation (Notes 17 and 26)			125	ps
Slew Rate Matching	(Notes 18, 27 and 28)			20%	
V_{high}	Voltage High (Notes 17, and 20) (Figure 14)	660	700	850	mV
V_{low}	Voltage Low (Notes 17, and 21) (Figure 14)	-150	0	+150	mV
Input Slew Rate	(Note 29 and 32)	0.35			V/ns
V_{cross} absolute	Absolute Crossing Point Voltages (Notes 12, 17 and 24) Relative Crossing Point Voltages can be calculated (Notes 16, 17 and 24) (Figure 16)	250		550	mV
Total ΔV_{cross}	Total Variation of Vcross Over All Edges (Notes 17 and 25)			140	mV
Duty Cycle	(Note 18) (Figure 15)	45		55	%
V_{ovs}	Maximum Voltage (Overshoot) (Notes 17 and 22) (Figure 14)			$V_{\text{high}} + 0.3$	V
V_{uds}	Maximum Voltage (Undershoot) (Notes 17 and 23) (Figure 14)			$V_{\text{low}} - 0.3$	V
V_{rb}	Ringback Voltage (Note 17) (Figure 14)	0.2		N/A	V
$T_{\text{oe_lat}}$	OE Latency (Note 11)	4	6	12	Cycles
t_{pd}	Input-to-Output Delay CLK_IN, DIF_[3:0] (Note 31)	0.6	1.0	1.4	ns
t_{SKEW}	Output-to-Output Skew across all 4 outputs DIF_[3:0] (Notes 30 and 31)	0	30	100	ps
$T_{\text{SKEW}(0-0)}$	Output-to-Output Skew between 2 output pairs controlled by the same OE DIF_[3:0] (Notes 30 and 31)	0	5	20	ps
$t_{\text{JITTER}\phi}$	Additive RMS Phase Jitter $f_{\text{carrier}} = 156.25\text{ MHz}$, 12 kHz – 20 MHz Integrated Range		46	80	fs

Product parametric performance is indicated in the Electrical Characteristics for the listed test conditions, unless otherwise noted. Product performance may not be indicated by the Electrical Characteristics if operated under different conditions.

11. Time from deassertion until outputs are >200 mV.

12. Measured at crossing point where the instantaneous voltage value of the rising edge of CLK equals the falling edge of CLK#.

13. Measured from $V_{\text{OL}} = 0.175\text{ V}$ to $V_{\text{OH}} = 0.525\text{ V}$. Only valid for Rising Clock and Falling Clock#.

14. This measurement refers to the total variation from the lowest crossing point to the highest, regardless of which edge is crossing

15. Test configuration is $R_S = 33.2\ \Omega$, $R_P = 49.9$, $C_L = 2\text{ pF}$, $R_{\text{REF}} = 475\ \Omega$.

16. Vcross(rel) Min and Max are derived using the following, $V_{\text{cross}(rel)}\text{ Min} = 0.250 + 0.5 (V_{\text{high avg}} - 0.700)$. $V_{\text{cross}(rel)}\text{ Max} = 0.550 - 0.5 (0.700 - V_{\text{high avg}})$. (see Figure 16 for further clarification).

17. Measurement taken from Single Ended waveform.

18. Measurement taken from differential waveform.

19. Unless otherwise noted, all specifications in this table apply to all frequencies.

20. V_{high} is defined as the statistical average High value as obtained by using the Oscilloscope V_{high} Math function.

21. V_{low} is defined as the statistical average Low value as obtained by using the Oscilloscope V_{low} Math function.

22. Overshoot is defined as the absolute value of the maximum voltage.

23. Undershoot is defined as the absolute value of the minimum voltage.

24. The crossing point must meet the absolute and relative crossing point specifications simultaneously.

25. ΔV_{cross} is defined as the total variation of all crossing voltages of Rising CLOCK and Falling CLOCK#. This is the maximum allowed variation in Vcross for any particular system.

26. Measured with oscilloscope, averaging off, using min max statistics. Variation is the delta between min and max.

27. Matching applies to rising edge rate for clock and falling edge rate for Clock#. It is measured using a $\pm 75\text{ mV}$ window centered on the average crosspoint where clock rising meets Clock# falling. The median crosspoint is used to calculate the voltage threshold the oscilloscope is to use for the edge rate calculations.

28. Slew Rate matching is derived using the following, $2 * (T_{\text{rise}} - T_{\text{fall}}) / (T_{\text{rise}} + T_{\text{fall}})$.

29. Input slew rate is based on single ended measurement. This is the minimum input slew rate at which the NB3L204K devices are guaranteed to meet all performance specifications.

30. Measured into fixed 2 pF load cap. Input to output skew is measured at the first output edge following the corresponding input.

31. Measured from differential cross-point to differential cross-point with scope averaging on to find mean value.

32. The differential input clock is expected to be sourced from a high performance clock oscillator.

33. Measured at $3.3\text{ V} \pm 10\%$ with typical HCSL input levels.

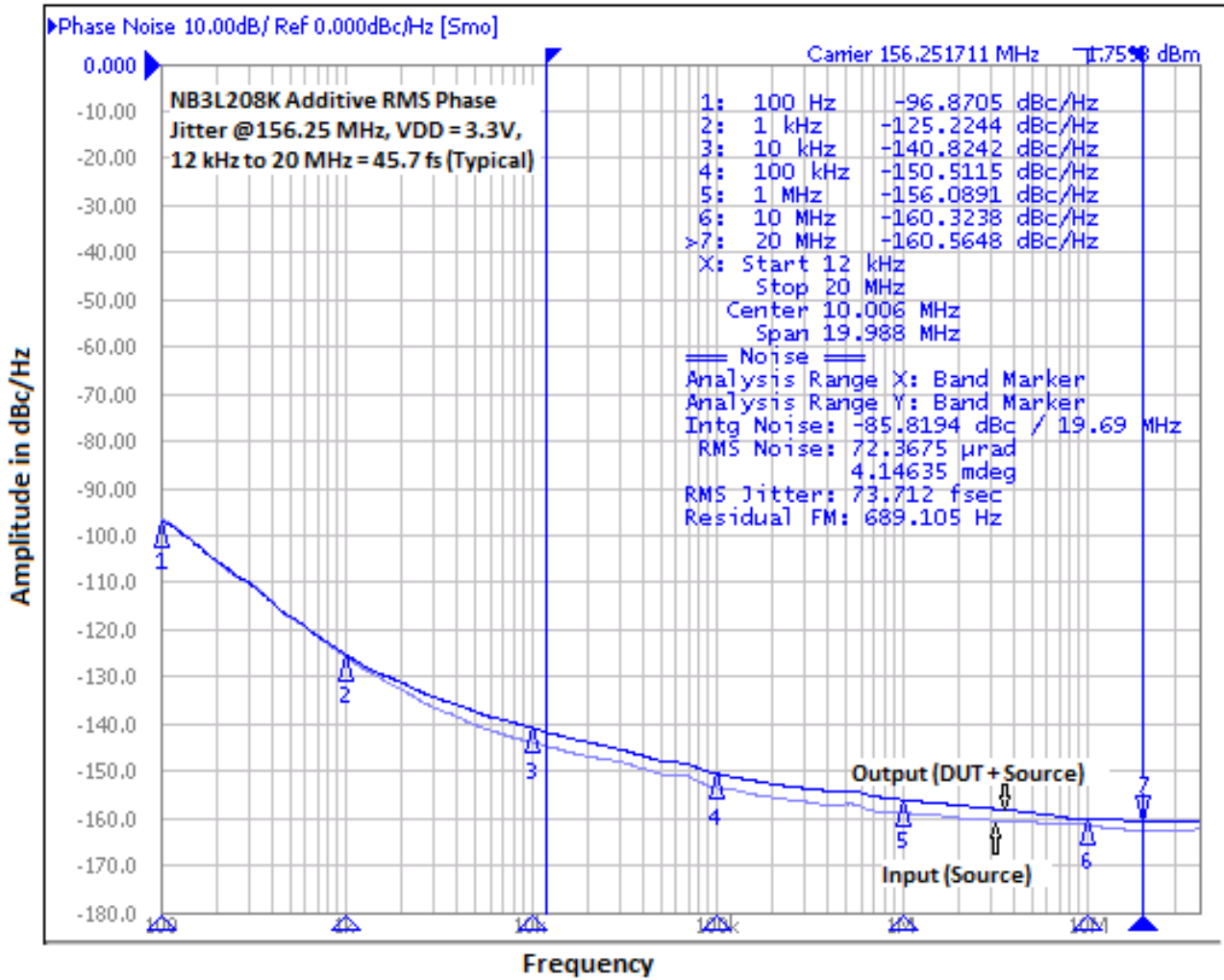

Figure 3. Typical Phase Noise Plot at $f_{\text{carrier}} = 156.25 \text{ MHz}$ at an Operating Voltage of 3.3 V, Room Temperature

The above phase noise data was captured using Agilent E5052A/B. The data displays the input phase noise and output phase noise used to calculate the additive phase jitter at a specified integration range. The additive RMS phase jitter contributed by the device (integrated between 12 kHz and 20 MHz) is 45.7 fs.

The additive RMS phase jitter performance of the fanout buffer is highly dependent on the phase noise of the input source.

To obtain the most accurate additive phase noise measurement, it is vital that the source phase noise be notably lower than that of the DUT. If the phase noise of the source is similar or greater than the device under test output, the source noise will dominate the additive phase jitter calculation and lead to an artificially low result for the additive phase noise measurement within the integration range.

$$\text{Additive RMS phase jitter} = \sqrt{\text{RMS phase jitter of output}^2 - \text{RMS phase jitter of input}^2}$$

$$45.7 \text{ fs} = \sqrt{73.7 \text{ fs}^2 - 57.8 \text{ fs}^2}$$

NB3L204K

Table 6. ELECTRICAL CHARACTERISTICS – PHASE JITTER PARAMETERS

($V_{DD} = V_{DD_O} = 3.3\text{ V} \pm 10\%$ or $2.5\text{ V} \pm 5\%$, $T_A = -40^\circ\text{C}$ to 85°C)

Symbol	Parameter	Conditions (Notes 34 and 39)	Min	Typ	Max	Unit
$t_{jphPCIeG1}$	Additive Phase Jitter	PCIe Gen 1 (Notes 35 and 36)			10	ps (p-p)
$t_{jphPCIeG2}$		PCIe Gen 2 Lo Band 10 kHz < f < 1.5 MHz (Notes 35 and 38)			0.3	ps (rms)
		PCIe Gen 2 High Band 1.5 MHz < f < Nyquist (50 MHz) (Notes 35 and 38)			0.7	ps (rms)
$t_{jphPCIeG3}$		PCIe Gen 3 (PLL BW of 2–4 MHz, CDR = 10 MHz) (Notes 35 and 38)			0.3	ps (rms)
$t_{jPCIeG3}$		PCIe Gen 3 (PLL BW= 2–4 MHz or 2–5 MHz, CDR = 10 MHz) (Notes 35 and 38)		0.07	0.4	ps
$t_{jPCIeG4}$		PCIe Gen 4 (PLL BW= 2–4 MHz or 2–5 MHz, CDR = 10 MHz) (Notes 35 and 38)		0.07	0.4	ps
t_{jphQPI_SMI}		QPI & SMI (100.00 MHz or 133.33 MHz, 4.8 Gb/s, 6.4 Gb/s 12UI) (Notes 37 and 38)			0.3	ps (rms)
		QPI & SMI (100.00 MHz, 8.0 Gb/s, 12UI) (Notes 37 and 38)			0.1	ps (rms)
		QPI & SMI (100.00 MHz, 9.6 Gb/s, 12UI) (Notes 37 and 38)			0.1	ps (rms)

Product parametric performance is indicated in the Electrical Characteristics for the listed test conditions, unless otherwise noted. Product performance may not be indicated by the Electrical Characteristics if operated under different conditions.

34. Applies to all outputs.

35. See <http://www.pcisig.com> for complete specs

36. Sample size of at least 100K cycles. This figures extrapolates to 108 ps pk-pk @ 1M cycles for a BER of 1-12.

37. Calculated from Intel-supplied Clock Jitter Tool v 1.6.3.

38. For RMS figures, additive jitter is calculated by solving the following equation: $(\text{Additive jitter})^2 = (\text{total jitter})^2 - (\text{input jitter})^2$

39. Guaranteed by design and characterization, not tested in production

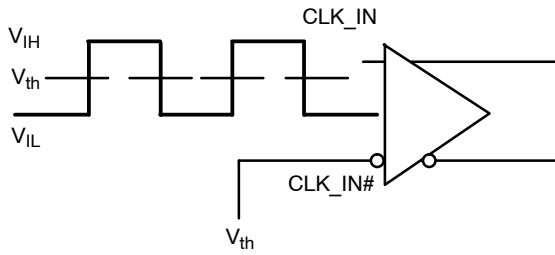

Figure 4. Differential Input Driven Single-Ended

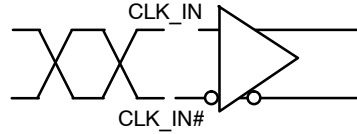

Figure 5. Differential Inputs Driven Differentially

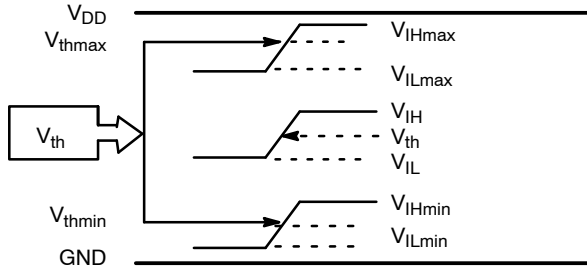

Figure 6. V_{th} Diagram

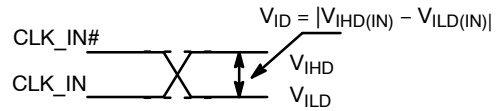

Figure 7. Differential Inputs Driven Differentially

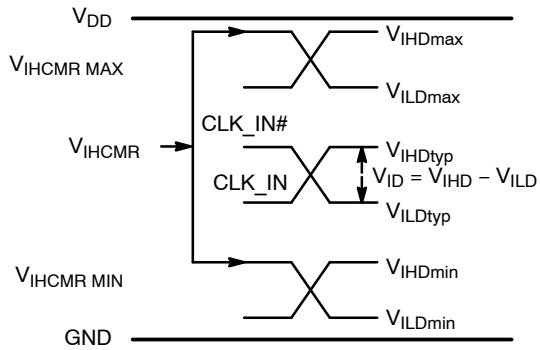

Figure 8. V_{IHCMR} Diagram

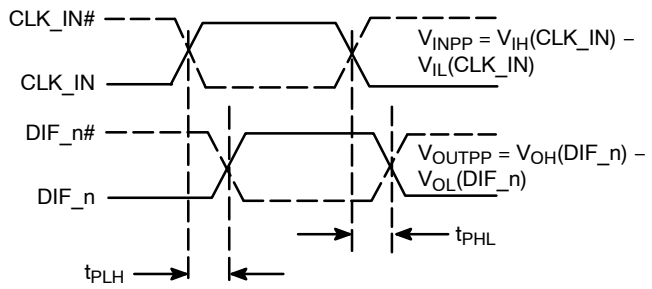
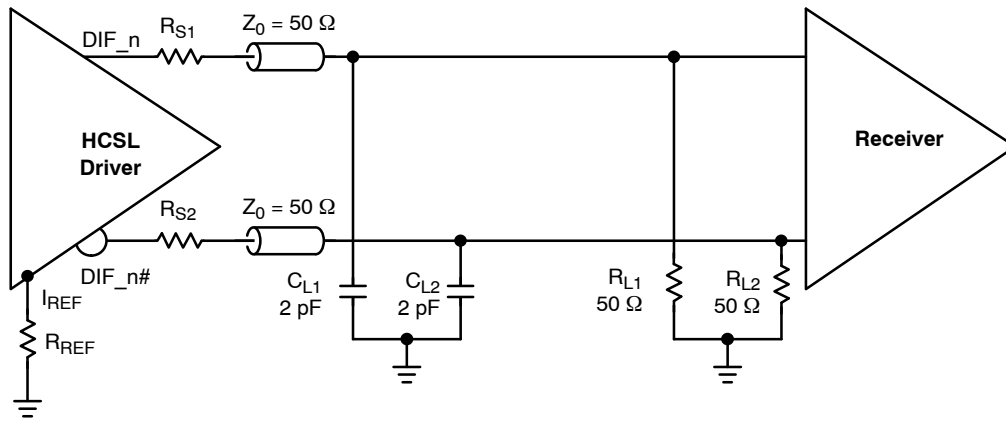

Figure 9. AC Reference Measurement

NB3L204K



- A. Connect 475 Ω resistor R_{REF} from I_{REF} pin to GND.
- B. R_{S1} , R_{S2} : 33 Ω for Test and Evaluation. Select to Minimizing Ringing.
- C. C_{L1} , C_{L2} : Receiver Input Simulation (for test only not added to application circuit).
- D. R_{L1} , R_{L2} Termination and Load Resistors Located at Received Inputs.

Figure 10. Typical Termination Configuration for Output Driver and Device Evaluation

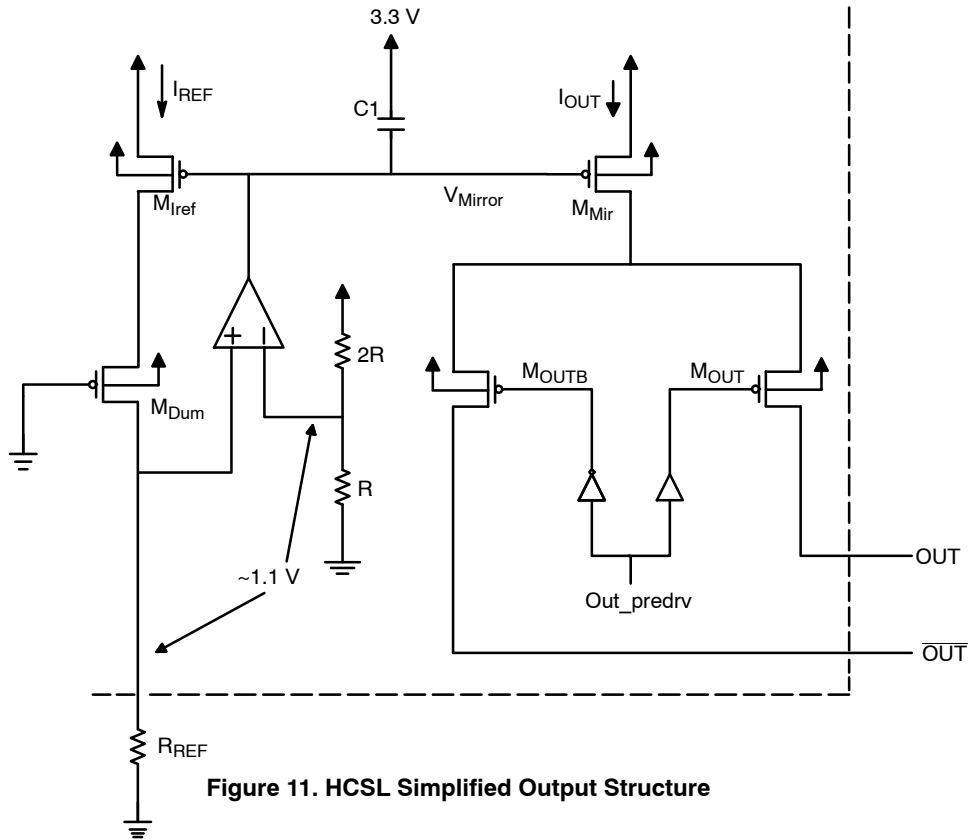

Figure 11. HCSL Simplified Output Structure

NB3L204K

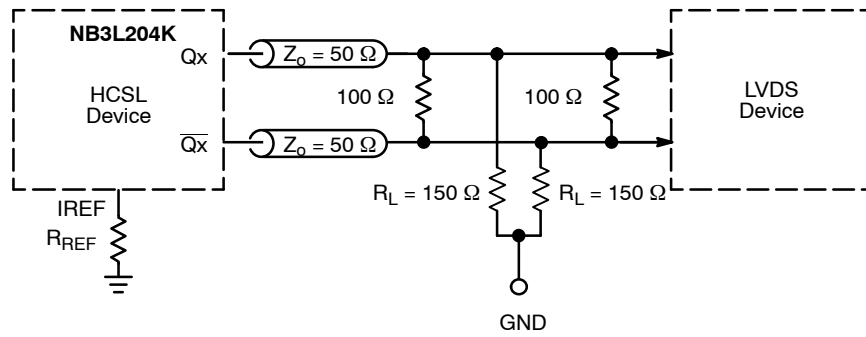

Figure 12. HCSL Interface Termination to LVDS

MEASUREMENT POINTS FOR DIFFERENTIAL

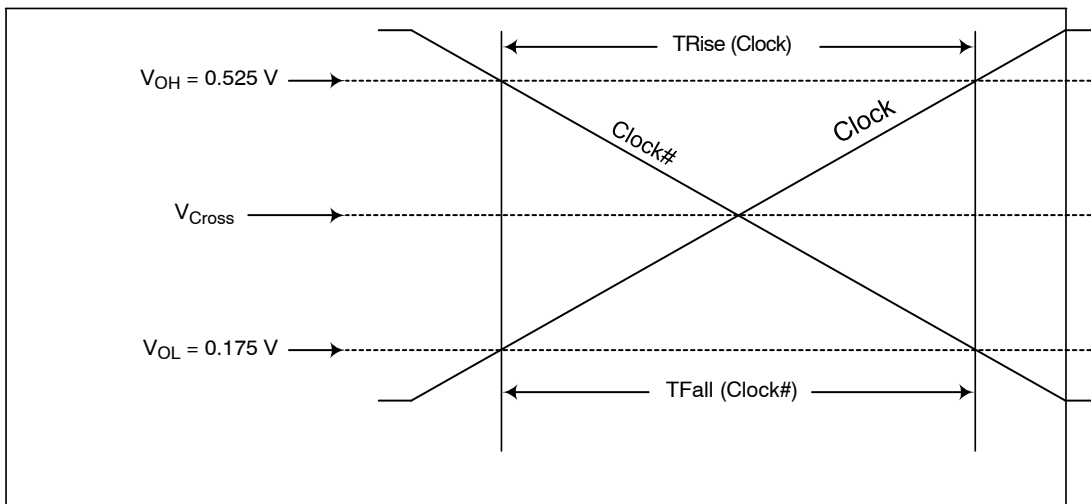

Figure 13. Single-Ended Measurement Points for Trise, Tfall

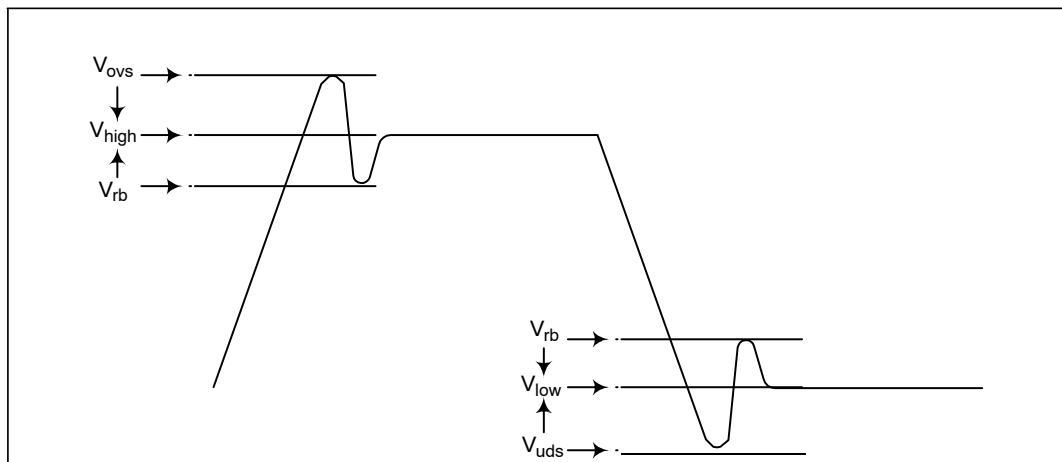

Figure 14. Single-Ended Measurement Points for V_{OVS} , V_{UDS} , V_{RB}

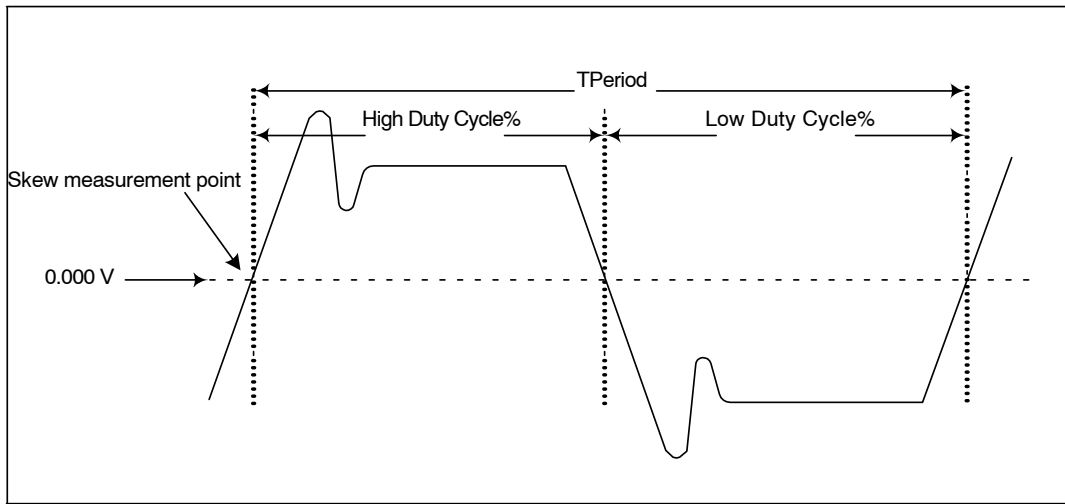

Figure 15. Differential (CLOCK – CLOCK#) Measurement Points (Tperiod, Duty Cycle)

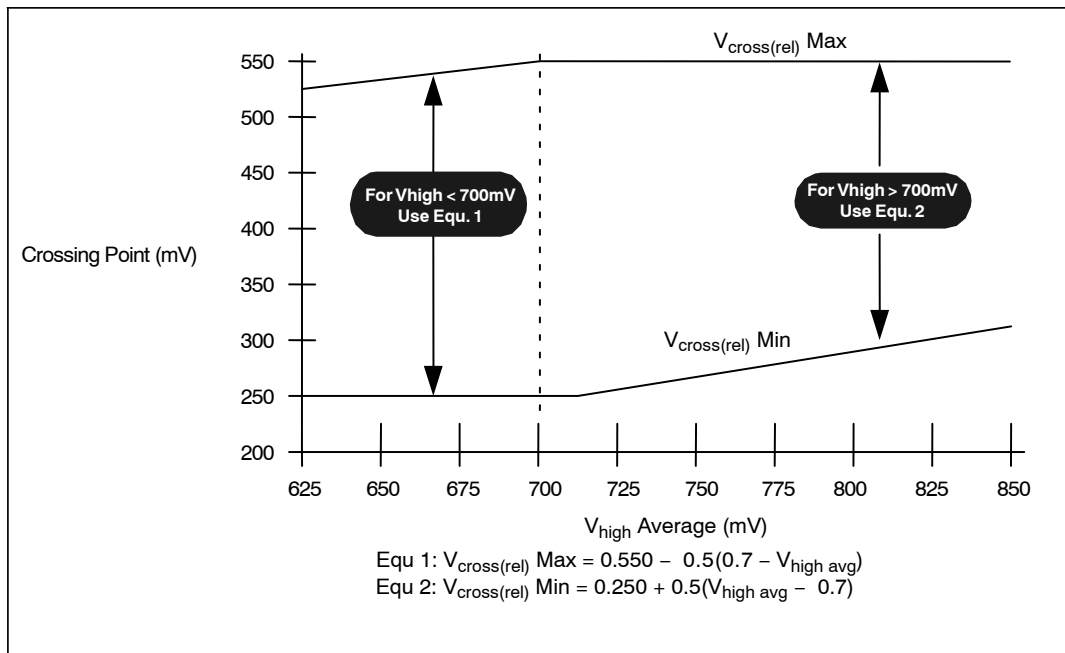

Figure 16. V_{cross} Range Clarification (Note 40)

40. The picture above illustrates the effect of V_{high} above and below 700 mV on the V_{cross} range. The purpose of this is to prevent a 250 mV V_{cross} with an 850 mV V_{high} . In addition, this prevents the case of a 550 mV V_{cross} with a 660 mV V_{high} . The actual specification for V_{cross} is dependent upon the measured amplitude of V_{high} .

NB3L204K

Signal and Feature Operation

Table 7. OE# FUNCTIONALITY (Notes 41, 42 and 43)

CLK_IN / CLK_IN#	OE# (Pin)	DIF	DIF #	Notes
Running	1	Low	Low	41
Running	0	Running	Running	
Not Running	x	x	x	

41. The outputs are tri-stated, but the termination networks pull them low

42. OE# pins are asynchronous asserted-low signals.

43. Each OE# pin controls two pair of DIF outputs.

OE# Assertion (Transition from '1' to '0')

All differential outputs that were tri-stated (low due to termination pull down) will resume normal operation in a glitch free manner. The latency from the assertion to active outputs is 4 – 12 DIF clock periods.

Note: Input clock must remain running for a minimum of 12 clock cycles.

OE# De-Assertion (Transition from '0' to '1')

The maximum latency from the de-assertion to tristated (low due to termination pull down) outputs is 12 DIF clock periods.

Table 8. NB3L204K RESISTIVE LUMPED TEST LOADS FOR DIFFERENTIAL CLOCKS

Board Target Trace/Term Z	Reference R, I _{ref} = VDD/(3*R _{REF})	Output Current	V _{OH} @ Z	R _s	R _p
100 Ω Differential 50 Ω Single-Ended	R _{REF} = 475 Ω 1%, I _{REF} = 2.32 mA	I _{OH} = 6 * I _{REF}	0.7 V @ 50	33 Ω 5%	50 Ω 5%
85 Ω Differential 43 Ω Single-Ended	R _{REF} = 412 Ω, 1%, I _{REF} = 2.67 mA	I _{OH} = 6 * I _{REF}	0.7V @ 43.2	27 Ω 5%	43 Ω 5%

ORDERING INFORMATION

Device	Package	Shipping [†]
NB3L204KMNG	QFN24 (Pb-Free)	92 Units / Rail
NB3L204KMNTXG	QFN24 (Pb-Free)	3000 / Tape & Reel

[†]For information on tape and reel specifications, including part orientation and tape sizes, please refer to our Tape and Reel Packaging Specifications Brochure, BRD8011/D.

MECHANICAL CASE OUTLINE

PACKAGE DIMENSIONS

ON Semiconductor®

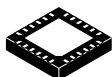

SCALE 2:1

QFN24, 4x4, 0.5P
CASE 485DJ
ISSUE O

DATE 28 OCT 2013

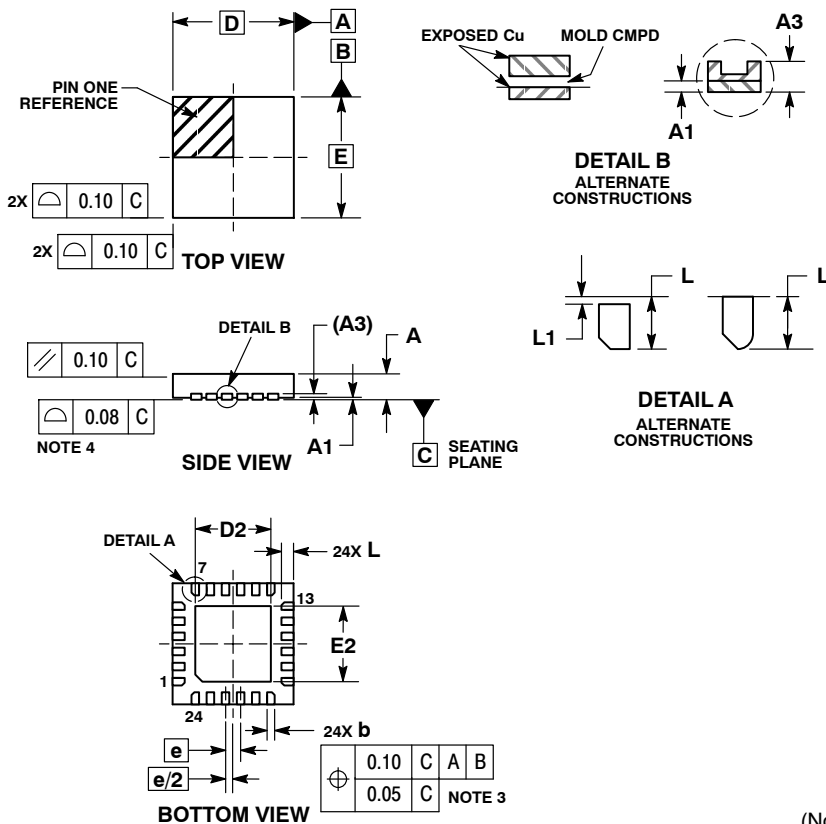

- NOTES:
1. DIMENSIONING AND TOLERANCING PER ASME Y14.5M, 1994.
 2. CONTROLLING DIMENSION: MILLIMETERS.
 3. DIMENSION b APPLIES TO PLATED TERMINAL AND IS MEASURED BETWEEN 0.25 AND 0.30 MM FROM THE TERMINAL TIP.
 4. COPLANARITY APPLIES TO THE EXPOSED PAD AS WELL AS THE TERMINALS.

MILLIMETERS		
DIM	MIN	MAX
A	0.80	0.90
A1	0.00	0.05
A3	0.20 REF	
b	0.20	0.30
D	4.00 BSC	
E2	2.40	2.60
E	4.00 BSC	
e	0.50 BSC	
L	0.30	0.50
L1	---	0.15

GENERIC MARKING DIAGRAM*

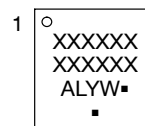

- XXXXXX= Specific Device Code
 A = Assembly Location
 L = Wafer Lot
 Y = Year
 W = Work Week
 ■ = Pb-Free Package

(Note: Microdot may be in either location)

*This information is generic. Please refer to device data sheet for actual part marking. Pb-Free indicator, "G" or microdot "■", may or may not be present.

RECOMMENDED SOLDERING FOOTPRINT*

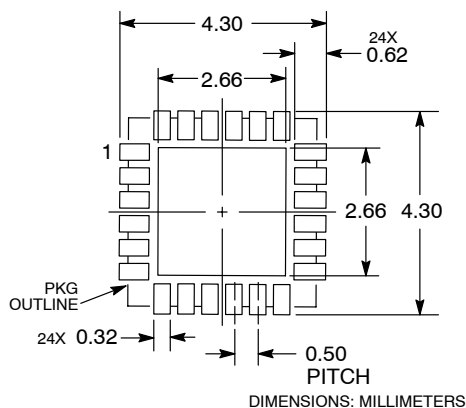

*For additional information on our Pb-Free strategy and soldering details, please download the ON Semiconductor Soldering and Mounting Techniques Reference Manual, SOLDERRM/D.

DOCUMENT NUMBER:	98AON79518F	Electronic versions are uncontrolled except when accessed directly from the Document Repository. Printed versions are uncontrolled except when stamped "CONTROLLED COPY" in red.
DESCRIPTION:	QFN24, 4X4, 0.5P	PAGE 1 OF 1

ON Semiconductor and ON are trademarks of Semiconductor Components Industries, LLC dba ON Semiconductor or its subsidiaries in the United States and/or other countries. ON Semiconductor reserves the right to make changes without further notice to any products herein. ON Semiconductor makes no warranty, representation or guarantee regarding the suitability of its products for any particular purpose, nor does ON Semiconductor assume any liability arising out of the application or use of any product or circuit, and specifically disclaims any and all liability, including without limitation special, consequential or incidental damages. ON Semiconductor does not convey any license under its patent rights nor the rights of others.

onsemi, **Onsemi**, and other names, marks, and brands are registered and/or common law trademarks of Semiconductor Components Industries, LLC dba "**onsemi**" or its affiliates and/or subsidiaries in the United States and/or other countries. **onsemi** owns the rights to a number of patents, trademarks, copyrights, trade secrets, and other intellectual property. A listing of **onsemi**'s product/patent coverage may be accessed at www.onsemi.com/site/pdf/Patent-Marking.pdf. **onsemi** reserves the right to make changes at any time to any products or information herein, without notice. The information herein is provided "as-is" and **onsemi** makes no warranty, representation or guarantee regarding the accuracy of the information, product features, availability, functionality, or suitability of its products for any particular purpose, nor does **onsemi** assume any liability arising out of the application or use of any product or circuit, and specifically disclaims any and all liability, including without limitation special, consequential or incidental damages. Buyer is responsible for its products and applications using **onsemi** products, including compliance with all laws, regulations and safety requirements or standards, regardless of any support or applications information provided by **onsemi**. "Typical" parameters which may be provided in **onsemi** data sheets and/or specifications can and do vary in different applications and actual performance may vary over time. All operating parameters, including "Typicals" must be validated for each customer application by customer's technical experts. **onsemi** does not convey any license under any of its intellectual property rights nor the rights of others. **onsemi** products are not designed, intended, or authorized for use as a critical component in life support systems or any FDA Class 3 medical devices or medical devices with a same or similar classification in a foreign jurisdiction or any devices intended for implantation in the human body. Should Buyer purchase or use **onsemi** products for any such unintended or unauthorized application, Buyer shall indemnify and hold **onsemi** and its officers, employees, subsidiaries, affiliates, and distributors harmless against all claims, costs, damages, and expenses, and reasonable attorney fees arising out of, directly or indirectly, any claim of personal injury or death associated with such unintended or unauthorized use, even if such claim alleges that **onsemi** was negligent regarding the design or manufacture of the part. **onsemi** is an Equal Opportunity/Affirmative Action Employer. This literature is subject to all applicable copyright laws and is not for resale in any manner.

ADDITIONAL INFORMATION

TECHNICAL PUBLICATIONS:

Technical Library: www.onsemi.com/design/resources/technical-documentation
onsemi Website: www.onsemi.com

ONLINE SUPPORT: www.onsemi.com/support

For additional information, please contact your local Sales Representative at www.onsemi.com/support/sales

Looking for pricing, stock, or lifecycle information?

Click below to explore more details on WIN SOURCE:

 [View NB3L204KMNTXG on WIN SOURCE](#)

 [ON Semiconductor](#) Information

Optimize Your Supply Chain with WIN SOURCE Solutions

-  Global Sourcing Solution
-  Obsolete Management
-  Cost Control Management
-  Shortage Management
-  Alternative Solution
-  Excess Inventory Management