



numonyx™

N25Q128

128-Mbit, 1.8 V, multiple I/O, 4-Kbyte subsector erase on boot sectors, XiP enabled, serial flash memory with 108 MHz SPI bus interface

Features

- SPI-compatible serial bus interface
- 108 MHz (maximum) clock frequency
- 1.7 V to 2 V single supply voltage
- Supports legacy SPI protocol and new Quad I/O or Dual I/O SPI protocol
- Quad/Dual I/O instructions resulting in an equivalent clock frequency up to 432 MHz:
- XiP mode for all three protocols
 - Configurable via volatile or non-volatile registers (enabling the memory to work in XiP mode directly after power on)
- Program/Erase suspend instructions
- Continuous read of entire memory via single instruction:
 - Fast Read
 - Quad or Dual Output Fast Read
 - Quad or Dual I/O Fast Read
- Flexible to fit application:
 - Configurable number of dummy cycles
 - Output buffer configurable
 - Fast POR instruction: to speed up power on phase
 - Reset function available upon customer request
- 64-byte user-lockable, one-time programmable (OTP) area
- Erase capability
 - Subsector (4-Kbyte) granularity in the 8 boot sectors (bottom or top parts).
 - Sector (64-Kbyte) granularity
- Write protections
 - Software write protection applicable to every 64-Kbyte sector (volatile lock bit)
 - Hardware write protection: protected area size defined by five non-volatile bits (BP0, BP1, BP2, BP3 and TB bit)

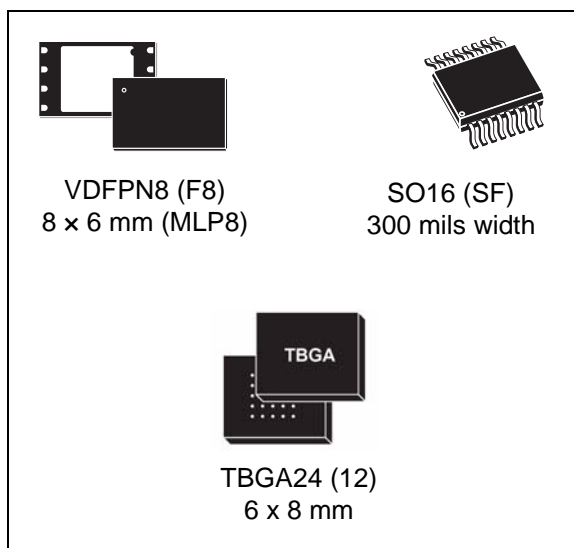

- Additional smart protections available upon customer request
- Deep Power-down mode: 5 μ A (typical)
- Electronic signature
 - JEDEC standard two-byte signature (BB18h)
 - Additional 2 Extended Device ID (EDID) bytes to identify device factory options
 - Unique ID code (UID) with 14 bytes read-only, available upon customer request
- 100,000 + program/erase cycles per sector
- More than 20 years data retention
- Packages
 - RoHS compliant

Contents

1	Description	12
2	Signal descriptions	16
2.1	Serial data output (DQ1)	16
2.2	Serial data input (DQ0)	16
2.3	Serial Clock (C)	16
2.4	Chip Select (S)	16
2.5	Hold (HOLD) or Reset (Reset)	17
2.6	Write protect/enhanced program supply voltage (\overline{W}/VPP), DQ2	18
2.7	V_{CC} supply voltage	18
2.8	V_{SS} ground	18
3	SPI Modes	19
4	SPI Protocols	21
4.1	Extended SPI protocol	21
4.2	Dual I/O SPI (DIO-SPI) protocol	21
4.3	Quad SPI (QIO-SPI) protocol	22
5	Operating features	23
5.1	Extended SPI Protocol Operating features	23
5.1.1	Read Operations	23
5.1.2	Page programming	23
5.1.3	Dual input fast program	23
5.1.4	Dual Input Extended Fast Program	23
5.1.5	Quad Input Fast Program	24
5.1.6	Quad Input Extended Fast Program	24
5.1.7	Subsector erase, sector erase and bulk erase	24
5.1.8	Polling during a write, program or erase cycle	24
5.1.9	Active power and standby power modes	24
5.1.10	Hold (or Reset) condition	25
5.2	Dual SPI (DIO-SPI) Protocol	27
5.2.1	Multiple Read Identification	27

5.2.2	Dual Command Fast reading	27
5.2.3	Page programming	27
5.2.4	Subsector Erase, Sector Erase and Bulk Erase	28
5.2.5	Polling during a Write, Program or Erase cycle	28
5.2.6	Read and Modify registers	28
5.2.7	Active Power and Standby Power modes	28
5.2.8	HOLD (or Reset) condition	28
5.3	Quad SPI (QIO-SPI) Protocol	29
5.3.1	Multiple Read Identification	29
5.3.2	Quad Command Fast reading	29
5.3.3	QUAD Command Page programming	29
5.3.4	Subsector Erase, Sector Erase and Bulk Erase	30
5.3.5	Polling during a Write, Program or Erase cycle	30
5.3.6	Read and Modify registers	31
5.3.7	Active Power and Standby Power modes	31
5.3.8	HOLD (or Reset) condition	31
5.3.9	VPP pin Enhanced Supply Voltage feature	31
6	Volatile and Non Volatile Registers	32
6.1	Legacy SPI Status Register	34
6.1.1	WIP bit	34
6.1.2	WEL bit	34
6.1.3	BP3, BP2, BP1, BP0 bits	34
6.1.4	TB bit	34
6.1.5	SRWD bit	35
6.2	Non Volatile Configuration Register	35
6.2.1	Dummy clock cycle NV configuration bits (NVCR bits from 15 to 12)	37
6.2.2	XIP NV configuration bits (NVCR bits from 11 to 9)	38
6.2.3	Output Driver Strength NV configuration bits (NVCR bits from 8 to 6)	38
6.2.4	Fast POR NV configuration bit (NVCR bit 5)	38
6.2.5	Hold (Reset) disable NV configuration bit (NVCR bit 4)	38
6.2.6	Quad Input NV configuration bit (NVCR bit 3)	38
6.2.7	Dual Input NV configuration bit (NVCR bit 2)	39
6.3	Volatile Configuration Register	39
6.3.1	Dummy clock cycle Volatile Configurations bits (VCR bits from 7 to 4)	40
6.3.2	XIP Volatile Configuration bits (VCR bit 3)	41
6.4	Volatile Enhanced Configuration Register	41

6.4.1	Quad Input Command VECR<7>	42
6.4.2	Dual Input Command VECR<6>	42
6.4.3	Reset/Hold disable VECR<4>	43
6.4.4	Accelerator pin enable: QIO-SPI protocol / QIFP/QIEFP VECR<3>	43
6.4.5	Output Driver Strength VECR<2:0>	43
6.5	Flag Status Register	44
6.5.1	P/E Controller Status bit	45
6.5.2	Erase Suspend Status bit	45
6.5.3	Erase Status bit	45
6.5.4	Program Status bit	46
6.5.5	VPP Status bit	46
6.5.6	Program Suspend Status bit	46
6.5.7	Protection Status bit	47
7	Protection modes	48
7.1	SPI Protocol-related protections	48
7.2	Specific hardware and software protection	48
8	Memory organization	52
9	Instructions	76
9.1	Extended SPI Instructions	76
9.1.1	Read Identification (RDID)	79
9.1.2	Read Data Bytes (READ)	80
9.1.3	Read Data Bytes at Higher Speed (FAST_READ)	81
9.1.4	Dual Output Fast Read (DOFR)	82
9.1.5	Dual I/O Fast Read	83
9.1.6	Quad Output Fast Read	84
9.1.7	Quad I/O Fast Read	85
9.1.8	Read OTP (ROTP)	86
9.1.9	Write Enable (WREN)	87
9.1.10	Write Disable (WRDI)	88
9.1.11	Page Program (PP)	89
9.1.12	Dual Input Fast Program (DIFP)	91
9.1.13	Dual Input Extended Fast Program	93
9.1.14	Quad Input Fast Program	93
9.1.15	Quad Input Extended Fast Program	94

9.1.16	Program OTP instruction (POTP)	95
9.1.17	Subsector Erase (SSE)	97
9.1.18	Sector Erase (SE)	98
9.1.19	Bulk Erase (BE)	99
9.1.20	Program/Erase Suspend	100
9.1.21	Program/Erase Resume	101
9.1.22	Read Status Register (RDSR)	102
9.1.23	Write status register (WRSR)	102
9.1.24	Read Lock Register (RDLR)	104
9.1.25	Write to Lock Register (WRLR)	105
9.1.26	Read Flag Status Register	106
9.1.27	Clear Flag Status Register	106
9.1.28	Read NV Configuration Register	107
9.1.29	Write NV Configuration Register	107
9.1.30	Read Volatile Configuration Register	108
9.1.31	Write Volatile Configuration Register	109
9.1.32	Read Volatile Enhanced Configuration Register	110
9.1.33	Write Volatile Enhanced Configuration Register	110
9.1.34	Deep Power-down (DP)	111
9.1.35	Release from Deep Power-down (RDP)	112
9.2	DIO-SPI Instructions	113
9.2.1	Multiple I/O Read Identification protocol	115
9.2.2	Dual Command Fast Read (DCFR)	116
9.2.3	Read OTP (ROTP)	116
9.2.4	Write Enable (WREN)	117
9.2.5	Write Disable (WRDI)	117
9.2.6	Dual Command Page Program (DCPP)	118
9.2.7	Program OTP instruction (POTP)	119
9.2.8	Subsector Erase (SSE)	120
9.2.9	Sector Erase (SE)	121
9.2.10	Bulk Erase (BE)	121
9.2.11	Program/Erase Suspend	122
9.2.12	Program/Erase Resume	122
9.2.13	Read Status Register (RDSR)	124
9.2.14	Write status register (WRSR)	124
9.2.15	Read Lock Register (RDLR)	125
9.2.16	Write to Lock Register (WRLR)	125

9.2.17	Read Flag Status Register	126
9.2.18	Clear Flag Status Register	127
9.2.19	Read NV Configuration Register	127
9.2.20	Write NV Configuration Register	128
9.2.21	Read Volatile Configuration Register	128
9.2.22	Write Volatile Configuration Register	129
9.2.23	Read Volatile Enhanced Configuration Register	130
9.2.24	Write Volatile Enhanced Configuration Register	130
9.2.25	Deep Power-down (DP)	131
9.2.26	Release from Deep Power-down (RDP)	132
9.3	QIO-SPI Instructions	132
9.3.1	Multiple I/O Read Identification (MIORDID)	134
9.3.2	Quad Command Fast Read (QCFR)	135
9.3.3	Read OTP (ROTP)	137
9.3.4	Write Enable (WREN)	138
9.3.5	Write Disable (WRDI)	139
9.3.6	Quad Command Page Program (QCPP)	139
9.3.7	Program OTP instruction (POTP)	141
9.3.8	Subsector Erase (SSE)	142
9.3.9	Sector Erase (SE)	143
9.3.10	Bulk Erase (BE)	144
9.3.11	Program/Erase Suspend	144
9.3.12	Program/Erase Resume	145
9.3.13	Read Status Register (RDSR)	146
9.3.14	Write status register (WRSR)	147
9.3.15	Read Lock Register (RDLR)	148
9.3.16	Write to Lock Register (WRLR)	149
9.3.17	Read Flag Status Register	150
9.3.18	Clear Flag Status Register	151
9.3.19	Read NV Configuration Register	152
9.3.20	Write NV Configuration Register	153
9.3.21	Read Volatile Configuration Register	154
9.3.22	Write Volatile Configuration Register	155
9.3.23	Read Volatile Enhanced Configuration Register	156
9.3.24	Write Volatile Enhanced Configuration Register	157
9.3.25	Deep Power-down (DP)	159
9.3.26	Release from Deep Power-down (RDP)	160

10	XIP Operations	161
10.1	Enter XIP mode by setting the Non Volatile Configuration Register	162
10.2	Enter XIP mode by setting the Volatile Configuration Register	164
10.3	XIP mode hold and exit	165
10.4	XIP Memory reset after a controller reset	166
11	Power-up and power-down	167
11.1	Fast POR	169
11.2	Rescue sequence in case of power loss during WRNVCR	169
12	Initial delivery state	170
13	Maximum rating	170
14	DC and AC parameters	171
15	Package mechanical	178
16	Ordering information	182
17	Revision history	184

List of tables

Table 1.	Signal names	13
Table 2.	Device Status after Reset Low Pulse	26
Table 3.	Status register format	34
Table 4.	Non-Volatile Configuration Register	36
Table 5.	Maximum allowed frequency (MHz).	37
Table 6.	Volatile Configuration Register	40
Table 7.	Volatile Enhanced Configuration Register	42
Table 8.	Flag Status Register	45
Table 9.	Software protection truth table (Sectors 0 to 255, 64 Kbyte)	49
Table 10.	Protected area sizes (TB bit = 0)	50
Table 11.	Protected area sizes (TB bit = 1)	51
Table 12.	Memory organization (uniform).	53
Table 13.	Memory organization (bottom)	60
Table 14.	Memory organization (top)	68
Table 15.	Instruction set: extended SPI protocol	78
Table 16.	Read Identification data-out sequence	80
Table 17.	Extended Device ID table (first byte)	80
Table 18.	Suspend Parameters	100
Table 19.	Operations Allowed / Disallowed During Device States	101
Table 20.	Protection modes	104
Table 21.	Lock Register out	105
Table 22.	Lock Register in	106
Table 23.	Instruction set: DIO-SPI protocol	114
Table 24.	Instruction set: QIO-SPI protocol	133
Table 25.	NVCR XIP bits setting example	163
Table 26.	VCR XIP bits setting example.	164
Table 27.	Power-up timing and VWI threshold	168
Table 28.	Absolute maximum ratings	170
Table 29.	Operating conditions.	171
Table 30.	AC measurement conditions.	171
Table 31.	Capacitance	171
Table 32.	DC Characteristics	172
Table 33.	AC Characteristics	173
Table 34.	Reset Conditions	175
Table 35.	VDFPN8 (MLP8) 8-lead very thin dual flat package no lead, 8 × 6 mm, package mechanical data	178
Table 36.	SO16 wide - 16-lead plastic small outline, 300 mils body width, mechanical data	179
Table 37.	TBGA 6x8 mm 24-ball package dimensions.	181
Table 38.	Ordering information scheme	182
Table 39.	Valid Order Information Line Items	183
Table 40.	Document revision history	184

List of figures

Figure 1.	Logic diagram	13
Figure 2.	VDFPN8 connections	14
Figure 3.	SO16 connections	14
Figure 4.	BGA connections	15
Figure 5.	Bus master and memory devices on the SPI bus	19
Figure 6.	Extended SPI protocol example	20
Figure 7.	Hold condition activation	25
Figure 8.	Non Volatile and Volatile configuration Register Scheme	33
Figure 9.	Block diagram	52
Figure 10.	Read identification instruction and data-out sequence	80
Figure 11.	Read Data Bytes instruction and data-out sequence	81
Figure 12.	Read Data Bytes at Higher Speed instruction and data-out sequence	82
Figure 13.	Dual Output Fast Read instruction sequence	83
Figure 14.	Dual I/O Fast Read instruction sequence	84
Figure 15.	Quad Input/Output Fast Read instruction sequence	85
Figure 16.	Quad Input/ Output Fast Read instruction sequence	86
Figure 17.	Read OTP instruction and data-out sequence	87
Figure 18.	Write Enable instruction sequence	88
Figure 19.	Write Disable instruction sequence	89
Figure 20.	Page Program instruction sequence	91
Figure 21.	Dual Input Fast Program instruction sequence	92
Figure 22.	Dual Input Extended Fast Program instruction sequence	93
Figure 23.	Quad Input Fast Program instruction sequence	94
Figure 24.	Quad Input Extended Fast Program instruction sequence	95
Figure 25.	Program OTP instruction sequence	96
Figure 26.	How to permanently lock the OTP bytes	97
Figure 27.	Subsector Erase instruction sequence	98
Figure 28.	Sector Erase instruction sequence	99
Figure 29.	Bulk Erase instruction sequence	99
Figure 30.	Read Status Register instruction sequence	102
Figure 31.	Write Status Register instruction sequence	103
Figure 32.	Read Lock Register instruction and data-out sequence	104
Figure 33.	Write to Lock Register instruction sequence	105
Figure 34.	Read Flag Status Register instruction sequence	106
Figure 35.	Clear Flag Status Register instruction sequence	107
Figure 36.	Read NV Configuration Register instruction sequence	107
Figure 37.	Write NV Configuration Register instruction sequence	108
Figure 38.	Read Volatile Configuration Register instruction sequence	109
Figure 39.	Write Volatile Configuration Register instruction sequence	110
Figure 40.	Read Volatile Enhanced Configuration Register instruction sequence	110
Figure 41.	Write Volatile Enhanced Configuration Register instruction sequence	111
Figure 42.	Deep Power-down instruction sequence	112
Figure 43.	Release from Deep Power-down instruction sequence	113
Figure 44.	Multiple I/O Read Identification instruction and data-out sequence DIO-SPI	115
Figure 45.	Dual Command Fast Read instruction and data-out sequence DIO-SPI	116
Figure 46.	Read OTP instruction and data-out sequence DIO-SPI	117
Figure 47.	Write Enable instruction sequence DIO-SPI	117
Figure 48.	Write Disable instruction sequence DIO-SPI	118

Figure 49.	Dual Command Page Program instruction sequence DSP, 02h	118
Figure 50.	Dual Command Page Program instruction sequence DSP, A2h	119
Figure 51.	Dual Command Page Program instruction sequence DSP, D2h	119
Figure 52.	Program OTP instruction sequence DIO-SPI	120
Figure 53.	Subsector Erase instruction sequence DIO-SPI	120
Figure 54.	Sector Erase instruction sequence DIO-SPI	121
Figure 55.	Bulk Erase instruction sequence DIO-SPI	122
Figure 56.	Program/Erase Suspend instruction sequence DIO-SPI	122
Figure 57.	Program/Erase Resume instruction sequence DIO-SPI	123
Figure 58.	Read Status Register instruction sequence DIO-SPI	124
Figure 59.	Write Status Register instruction sequence DIO-SPI	124
Figure 60.	Read Lock Register instruction and data-out sequence DIO-SPI	125
Figure 61.	Write to Lock Register instruction sequence DIO-SPI	126
Figure 62.	Read Flag Status Register instruction sequence DIO-SPI	126
Figure 63.	Clear Flag Status Register instruction sequence DIO-SPI	127
Figure 64.	Read NV Configuration Register instruction sequence DIO-SPI	127
Figure 65.	Write NV Configuration Register instruction sequence DIO-SPI	128
Figure 66.	Read Volatile Configuration Register instruction sequence DIO-SPI	129
Figure 67.	Write Volatile Configuration Register instruction sequence DIO-SPI	129
Figure 68.	Read Volatile Enhanced Configuration Register instruction sequence DIO-SPI	130
Figure 69.	Write Volatile Enhanced Configuration Register instruction sequence DIO-SPI	131
Figure 70.	Deep Power-down instruction sequence	131
Figure 71.	Release from Deep Power-down instruction sequence	132
Figure 72.	Multiple I/O Read Identification instruction and data-out sequence QIO-SPI	135
Figure 73.	Quad Command Fast Read instruction and data-out sequence QSP, 0Bh	136
Figure 74.	Quad Command Fast Read instruction and data-out sequence QSP, 6Bh	136
Figure 75.	Quad Command Fast Read instruction and data-out sequence QSP, EBh	137
Figure 76.	Read OTP instruction and data-out sequence QIO-SPI	138
Figure 77.	Write Enable instruction sequence QIO-SPI	138
Figure 78.	Write Disable instruction sequence QIO-SPI	139
Figure 79.	Quad Command Page Program instruction sequence QIO-SPI, 02h	140
Figure 80.	Quad Command Page Program instruction sequence QIO-SPI, 12h	140
Figure 81.	Quad Command Page Program instruction sequence QIO-SPI, 32h	141
Figure 82.	Program OTP instruction sequence QIO-SPI	142
Figure 83.	Subsector Erase instruction sequence QIO-SPI	143
Figure 84.	Sector Erase instruction sequence QIO-SPI	143
Figure 85.	Bulk Erase instruction sequence QIO-SPI	144
Figure 86.	Program/Erase Suspend instruction sequence QIO-SPI	145
Figure 87.	Program/Erase Resume instruction sequence QIO-SPI	146
Figure 88.	Read Status Register instruction sequence QIO-SPI	147
Figure 89.	Write Status Register instruction sequence QIO-SPI	148
Figure 90.	Read Lock Register instruction and data-out sequence QIO-SPI	149
Figure 91.	Write to Lock Register instruction sequence QIO-SPI	150
Figure 92.	Read Flag Status Register instruction sequence QIO-SPI	151
Figure 93.	Clear Flag Status Register instruction sequence QIO-SPI	152
Figure 94.	Read NV Configuration Register instruction sequence QIO-SPI	153
Figure 95.	Write NV Configuration Register instruction sequence QIO-SPI	154
Figure 96.	Read Volatile Configuration Register instruction sequence QIO-SPI	155
Figure 97.	Write Volatile Configuration Register instruction sequence QIO-SPI	156
Figure 98.	Read Volatile Enhanced Configuration Register instruction sequence QIO-SPI	157
Figure 99.	Write Volatile Enhanced Configuration Register instruction sequence QIO-SPI	158
Figure 100.	Deep Power-down instruction sequence	159

Figure 101. Deep Power-down instruction sequence	160
Figure 102. N25Q128 Read functionality Flow Chart	162
Figure 103. XIP mode directly after power on	163
Figure 104. XiP: enter by VCR 2/2 (QIOFR in normal SPI protocol example).	165
Figure 105. Power-up timing, Fast POR selected	168
Figure 106. Power-up timing, Fast POR not selected	168
Figure 107. AC measurement I/O waveform	171
Figure 108. Reset AC waveforms: program or erase cycle is in progress.	174
Figure 109. Serial input timing	175
Figure 110. Write protect setup and hold timing during WRSR when SRWD=1	176
Figure 111. Hold timing	176
Figure 112. Output timing	177
Figure 113. VPP _H timing	177
Figure 114. VDFPN8 (MLP8) 8-lead very thin dual flat package no lead, 8 x 6 mm, package outline	178
Figure 115. SO16 wide - 16-lead plastic small outline, 300 mils body width, package outline	179
Figure 116. TBGA - 6 x 8 mm, 24-ball, mechanical package outline	180

1 Description

The N25Q128 is a 128 Mbit (16Mb x 8) serial Flash memory, with advanced write protection mechanisms. It is accessed by a high speed SPI-compatible bus and features the possibility to work in XIP (“eXecute in Place”) mode.

The N25Q128 supports innovative, high-performance quad/dual I/O instructions, these new instructions allow to double or quadruple the transfer bandwidth for read and program operations.

Furthermore the memory can be operated with 3 different protocols:

- Standard SPI (Extended SPI protocol)
- Dual I/O SPI
- Quad I/O SPI

The Standard SPI protocol is enriched by the new quad and dual instructions (Extended SPI protocol). For Dual I/O SPI (DIO-SPI) all the instructions codes, the addresses and the data are always transmitted across two data lines. For Quad I/O SPI (QIO-SPI) the instructions codes, the addresses and the data are always transmitted across four data lines thus enabling a tremendous improvement in both random access time and data throughput.

The memory can work in “XIP mode”, that means the device only requires the addresses and not the instructions to output the data. This mode dramatically reduces random access time thus enabling many applications requiring fast code execution without shadowing the memory content on a RAM.

The XIP mode can be used with QIO-SPI, DIO-SPI, or Extended SPI protocol, and can be entered and exited using different dedicated instructions to allow maximum flexibility: for applications required to enter in XIP mode right after power up of the device, this can be set as default mode by using dedicated Non Volatile Register (NVR) bits.

It is also possible to reduce the power on sequence time with the Fast POR (Power on Reset) feature, enabling a reduction of the latency time before the first read instruction can be performed. Another feature is the ability to pause and resume program and erase cycles by using dedicated Program/Erase Suspend and Resume instructions.

The N25Q128 memory offers the following additional Features to be configured by using the Non Volatile Configuration Register (NVCR) for default /Non-Volatile settings or by using the Volatile and Volatile Enhanced Configuration Registers for Volatile settings:

- the number of dummy cycles for fast read instructions (single, dual and, quad I/O) according to the operating frequency
- the output buffer impedance
- the type of SPI protocol (extended SPI, DIO-SPI or QIO-SPI)
- the required XIP mode
- Fast or standard POR sequence
- the Hold (Reset) functionality enabling/disabling

The memory is organized as 248 (64-Kbyte) main sectors, in products with Bottom or Top architecture there are 8 64-Kbyte boot sectors, and each boot sector is further divided into 16 4-Kbyte subsectors (128 subsectors in total). The boot sectors can be erased a 4-Kbyte subsector at a time or as a 64-Kbyte sector at a time. The entire memory can be also erased at a time or by sector.

The memory can be write protected by software using a mix of volatile and non-volatile protection features, depending on the application needs. The protection granularity is of 64-Kbyte (sector granularity) for volatile protections.

The N25Q128 has 64 one-time-programmable bytes (OTP bytes) that can be read and programmed using two dedicated instructions, Read OTP (ROTP) and Program OTP (POTP), respectively. These 64 bytes can be permanently locked by a particular Program OTP (POTP) sequence. Once they have been locked, they become read-only and this state cannot be reversed.

Many different N25Q128 configurations are available, please refer to the ordering scheme page for the possibilities. Additional features are available as security options (The Security features are described in a dedicated Application Note). Please contact your nearest Numonyx Sales office for more information.

Figure 1. Logic diagram

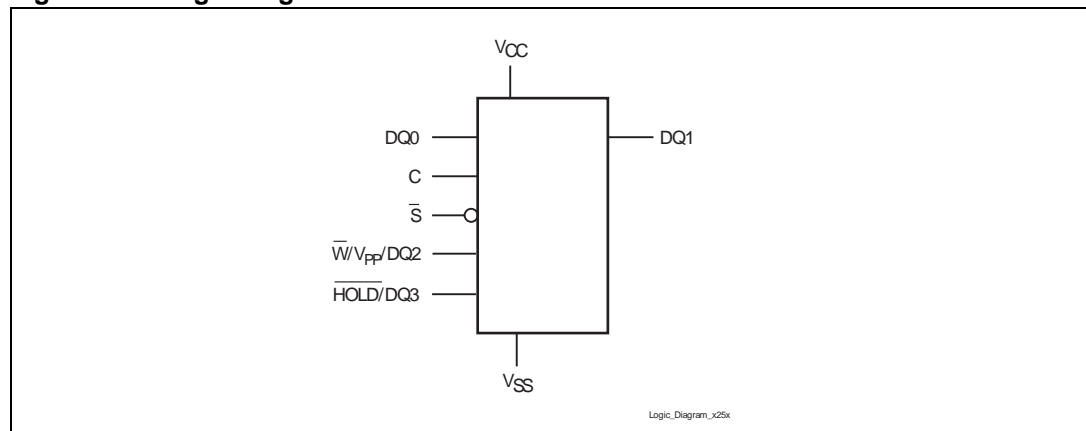

Note: Reset functionality is available in devices with a dedicated part number. See [Section 16: Ordering information](#).

Table 1. Signal names

Signal	Description	I/O
C	Serial Clock	Input
DQ0	Serial Data input	I/O ⁽¹⁾
DQ1	Serial Data output	I/O ⁽²⁾
\bar{S}	Chip Select	Input
$\bar{W}/VPP/DQ2$	Write Protect/Enhanced Program supply voltage/additional data I/O	I/O ⁽³⁾
$\bar{HOLD}/DQ3^{(4)}$	Hold (Reset function available upon customer request)/additional data I/O	I/O ⁽³⁾
V _{CC}	Supply voltage	–
V _{SS}	Ground	–

1. Provides dual and quad I/O for Extended SPI protocol instructions, dual I/O for Dual I/O SPI protocol instructions, and quad I/O for Quad I/O SPI protocol instructions.
2. Provides dual and quad instruction input for Extended SPI protocol, dual instruction input for Dual I/O SPI protocol, and quad instruction input for Quad I/O SPI protocol.
3. Provides quad I/O for Extended SPI protocol instructions, and quad I/O for Quad I/O SPI protocol instructions.
4. Reset functionality available with a dedicated part number. See [Section 16: Ordering information](#).

Note: There is an exposed central pad on the underside of the VDFPN8 package. This is pulled, internally, to VSS, and must not be connected to any other voltage or signal line on the PCB.

Figure 2. VDFPN8 connections

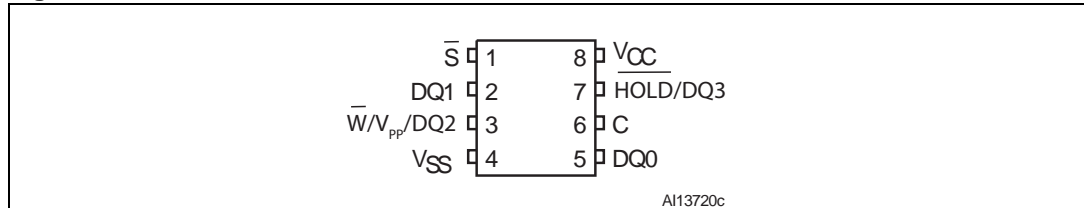

1. Reset functionality available in devices with a dedicated part number. See [Section 16: Ordering information](#).

Figure 3. SO16 connections

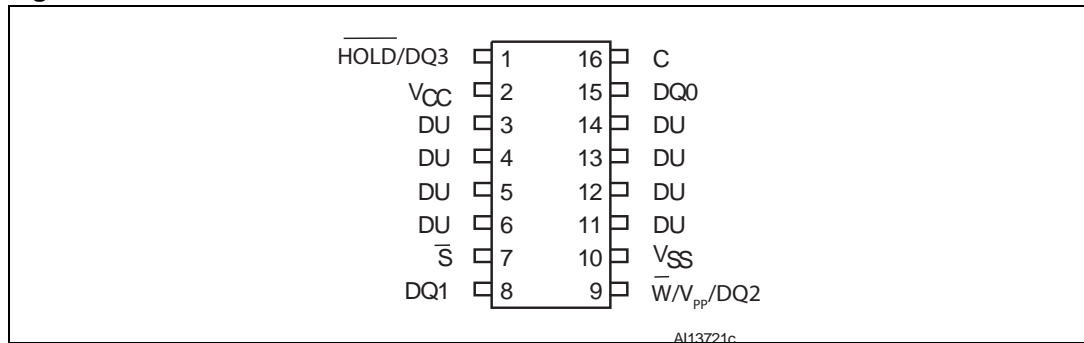

1. DU = don't use.
2. See [Package mechanical](#) section for package dimensions, and how to identify pin-1.
3. Reset functionality available in devices with a dedicated part number. See [Section 16: Ordering information](#).

Figure 4. BGA connections

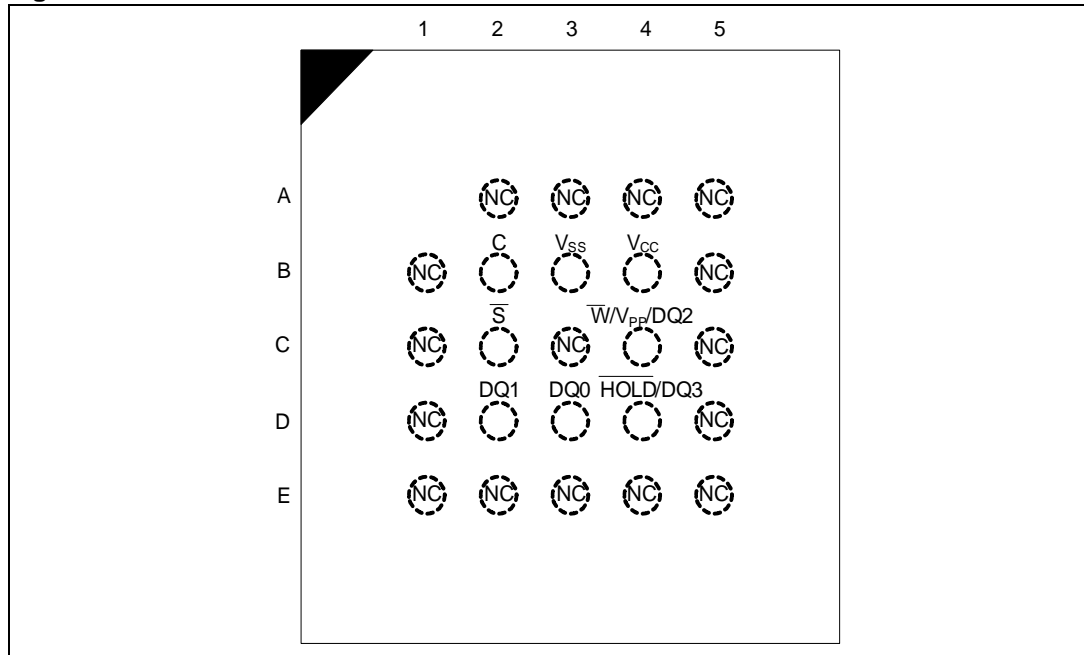

1. NC = No Connect.
2. See [Figure 116.: TBGA - 6 x 8 mm, 24-ball, mechanical package outline.](#)

2 Signal descriptions

2.1 Serial data output (DQ1)

This output signal is used to transfer data serially out of the device. Data are shifted out on the falling edge of Serial Clock (C). When used as an Input, It is latched on the rising edge of the Serial Clock (C).

In the Extended SPI protocol, during the Quad and Dual Input Fast Program (QIFP, DIFP) instructions and during the Quad and Dual Input Extended Fast Program (QIEFP, DIEFP) instructions, pin DQ1 is used also as an input.

In the Dual I/O SPI protocol (DIO-SPI) the DQ1 pin always acts as an input/output.

In the Quad I/O SPI protocol (QIO-SPI) the DQ1 pin always acts as an input/output, with the exception of the Program or Erase cycle performed with the Enhanced Program Supply Voltage (VPP). In this case the device temporarily goes in Extended SPI protocol. The protocol then becomes QIO-SPI as soon as the VPP pin voltage goes low.

2.2 Serial data input (DQ0)

This input signal is used to transfer data serially into the device. It receives instructions, addresses, and the data to be programmed. Values are latched on the rising edge of Serial Clock (C). Data are shifted out on the falling edge of the Serial Clock (C).

In the Extended SPI protocol, during the Quad and Dual Output Fast Read (QOFR, DOFR) and the Quad and Dual Input/Output Fast Read (QIOFR, DIOFR) instructions, pin DQ0 is also used as an input/output.

In the DIO-SPI protocol the DQ0 pin always acts as an input/output.

In the QIO-SPI protocol, the DQ0 pin always acts as an input/output, with the exception of the Program or Erase cycle performed with the VPP. In this case the device temporarily goes in Extended SPI protocol. Then, the protocol returns to QIO-SPI as soon as the VPP pin voltage goes low.

2.3 Serial Clock (C)

This input signal provides the timing for the serial interface. Instructions, addresses, or data present at serial data input (DQ0) are latched on the rising edge of Serial Clock (C). Data are shifted out on the falling edge of the Serial Clock (C).

2.4 Chip Select (\bar{S})

When this input signal is high, the device is deselected and serial data output (DQ1) is at high impedance. Unless an internal program, erase or write status register cycle is in progress, the device will be in the standby power mode (this is not the deep power-down mode). Driving Chip Select (\bar{S}) low enables the device, placing it in the active power mode.

After power-up, a falling edge on Chip Select (\bar{S}) is required prior to the start of any instruction.

2.5 Hold ($\overline{\text{HOLD}}$) or Reset ($\overline{\text{Reset}}$)

The Hold ($\overline{\text{HOLD}}$) signal is used to pause any serial communications with the device without deselecting the device.

Reset functionality is present instead of Hold in devices with a dedicated part number. See [Section 16: Ordering information](#).

During Hold condition, the Serial Data output (DQ1) is in high impedance, and Serial Data input (DQ0) and Serial Clock (C) are Don't Care.

To start the Hold condition, the device must be selected, with Chip Select ($\overline{\text{S}}$) driven Low.

For devices featuring Reset instead of Hold functionality, the Reset ($\overline{\text{Reset}}$) input provides a hardware reset for the memory.

When $\overline{\text{Reset}}$ ($\overline{\text{Reset}}$) is driven High, the memory is in the normal operating mode. When $\overline{\text{Reset}}$ ($\overline{\text{Reset}}$) is driven Low, the memory will enter the Reset mode. In this mode, the output is high impedance.

Driving $\overline{\text{Reset}}$ ($\overline{\text{Reset}}$) Low while an internal operation is in progress will affect this operation (write, program or erase cycle) and data may be lost.

In the Extended SPI protocol, during the $\overline{\text{QOFR}}$, $\overline{\text{QIOFR}}$, $\overline{\text{QIFP}}$ and the Quad Extended Fast Program ($\overline{\text{QIEFP}}$) instructions, the Hold ($\overline{\text{Reset}}$) / DQ3 is used as an input/output (DQ3 functionality).

In QIO-SPI, the $\overline{\text{Hold}}$ ($\overline{\text{Reset}}$) / DQ3 pin acts as an I/O (DQ3 functionality), and the $\overline{\text{HOLD}}$ ($\overline{\text{Reset}}$) functionality disabled when the device is selected. When the device is deselected ($\overline{\text{S}}$ signal is high), in parts with Reset functionality, it is possible to reset the device unless this functionality is not disabled by mean of dedicated registers bits.

The $\overline{\text{HOLD}}$ ($\overline{\text{Reset}}$) functionality can be disabled using bit 3 of the NVCR or bit 4 of the VECR.

2.6 Write protect/enhanced program supply voltage (\overline{W}/VPP), DQ2

$\overline{W}/VPP/DQ2$ can be used as:

- A protection control input.
- A power supply pin.
- I/O in Extended SPI protocol quad instructions and in QIO-SPI protocol instructions.

When the device is operated in Extended SPI protocol with single or dual instructions, the two functions \overline{W} or VPP are selected by the voltage range applied to the pin. If the \overline{W}/VPP input is kept in a low voltage range (0 V to VCC) the pin is seen as a control input. This input signal is used to freeze the size of the area of memory that is protected against program or erase instructions (as specified by the values in the BP[0:3] bits of the Status Register. (See [Table 3.: Status register format](#)).

If VPP is in the range of VPPH, it acts as an additional power supply during the Program or Erase cycles (See [Table 29.: Operating conditions](#)). In this case VPP must be stable until the Program or Erase algorithm is completed.

During the Extended SPI protocol, the QOFR and QIOFR instructions, and the QIO-SPI protocol instructions, the pin $\overline{W}/VPP/DQ2$ is used as an input/output (DQ2 functionality).

Using the Extended SPI protocol the QIFP, QIEFP and the QIO-SPI Program/Erase instructions, it is still possible to use the VPP additional power supply to speed up internal operations. However, to enable this possibility it is necessary to set bit 3 of the Volatile Enhanced Configuration Register to 0.

In this case the $\overline{W}/VPP/DQ2$ pin is used as an I/O pin until the end of the instruction sequence. After the last input data is shifted in, the application should apply VPP voltage to $\overline{W}/VPP/DQ2$ within 200 ms to speed up the internal operations. If the VPP voltage is not applied within 200 ms the Program/Erase operations start with standard speed.

The default value of the VECR bit 3 is 1, and the VPP functionality for Quad I/O modify instruction is disabled.

2.7 V_{CC} supply voltage

V_{CC} is the supply voltage.

2.8 V_{SS} ground

V_{SS} is the reference for the V_{CC} supply voltage.

3 SPI Modes

These devices can be driven by a micro controller with its SPI peripheral running in either of the two following modes:

CPOL=0, CPHA=0

CPOL=1, CPHA=1

For these two modes, input data is latched in on the rising edge of Serial Clock (C), and output data is available from the falling edge of Serial Clock (C).

The difference between the two modes, as shown in [Figure 5](#), is the clock polarity when the bus master is in standby mode and not transferring data:

C remains at 0 for (CPOL=0, CPHA=0)

C remains at 1 for (CPOL=1, CPHA=1)

Figure 5. Bus master and memory devices on the SPI bus

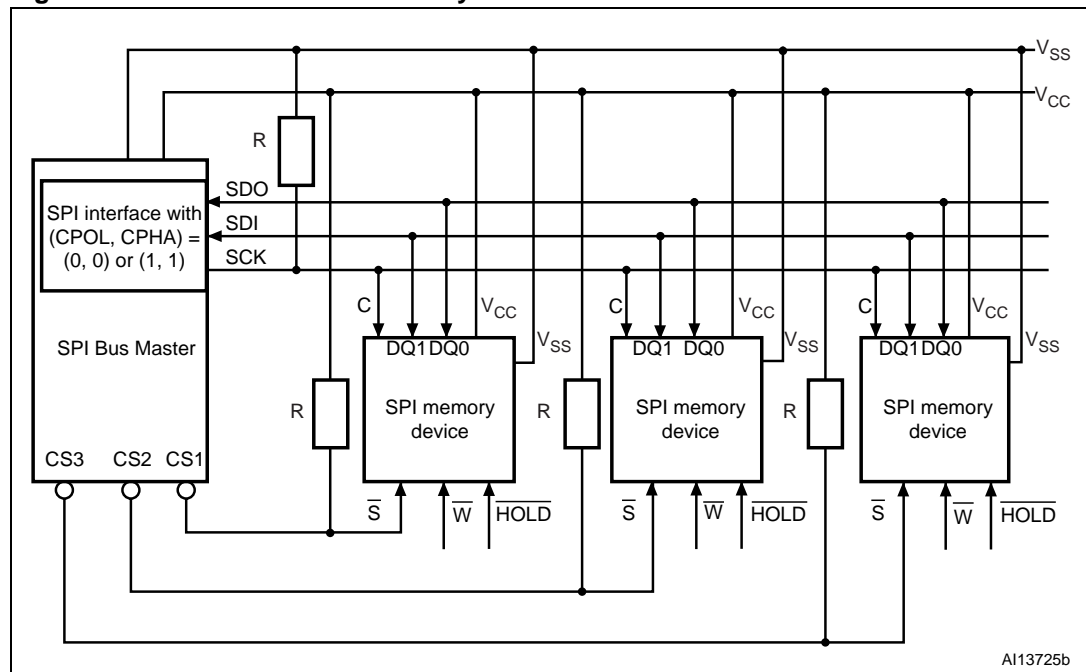

Shown here is an example of three devices working in Extended SPI protocol for simplicity connected to an MCU, on an SPI bus. Only one device is selected at a time, so only one device drives the serial data output (DQ1) line at a time; the other devices are high impedance. Resistors R ensures that the N25Q128 is not selected if the bus master leaves the \bar{S} line in the high impedance state. As the bus master may enter a state where all inputs/outputs are in high impedance at the same time (for example, when the bus master is reset), the clock line (C) must be connected to an external pull-down resistor so that, when all inputs/outputs become high impedance, the \bar{S} line is pulled High while the C line is pulled Low. This ensures that \bar{S} and C do not become High at the same time, and so that the t_{SHCH} requirement is met. The typical value of R is 100 kΩ, assuming that the time constant $R \cdot C_p$

(C_p = parasitic capacitance of the bus line) is shorter than the time during which the bus master leaves the SPI bus in high impedance.

Example: $C_p = 50$ pF, that is $R \cdot C_p = 5 \mu s \iff$ the application must ensure that the bus master never leaves the SPI bus in the high impedance state for a time period shorter than $5 \mu s$. The Write Protect (\overline{W}) and Hold (\overline{HOLD}) signals should be driven, High or Low as appropriate.

Figure 6. Extended SPI protocol example

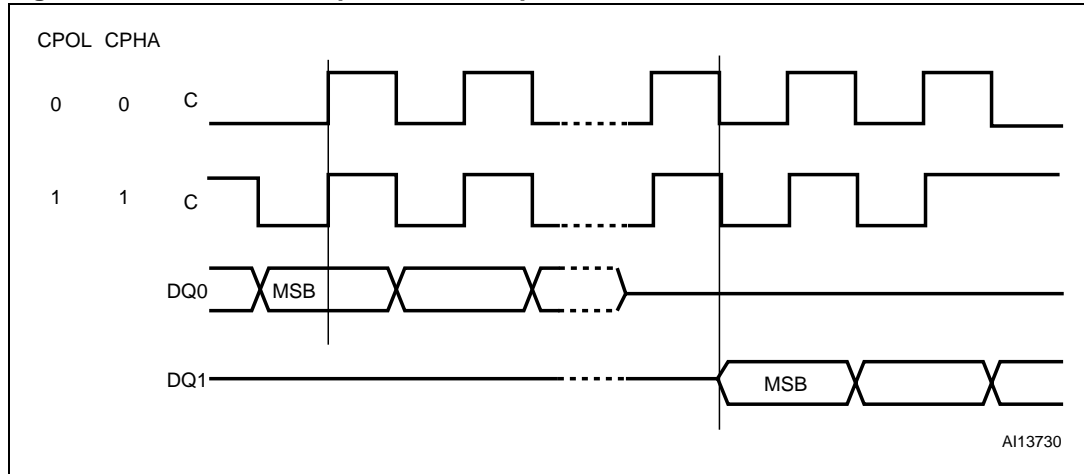

4 SPI Protocols

The N25Q128 memory can work with 3 different Serial protocols:

- Extended SPI protocol.
- Dual I/O SPI (DIO-SPI) protocol.
- Quad I/O SPI (QIO-SPI) protocol.

It is possible to choose among the three protocols by means of user volatile or non-volatile configuration bits. It's not possible to mix Extended SPI, DIO-SPI, and QIO-SPI protocols. The device can operate in XIP mode in all 3 protocols.

4.1 Extended SPI protocol

This is an extension of the standard (legacy) SPI protocol. Instructions are transmitted on a single data line (DQ0), while addresses and data are transmitted by one, two or four data lines (DQ0, DQ1, \bar{W}/VPP (DQ2) and HOLD / (DQ3) according to the instruction.

When used in the Extended SPI protocol, these devices can be driven by a micro controller in either of the two following modes:

- CPOL=0, CPHA=0
- CPOL=1, CPHA=1

Please refer to the SPI modes for a detailed description of these two modes

4.2 Dual I/O SPI (DIO-SPI) protocol

Dual I/O SPI (DIO-SPI) protocol: instructions, addresses and I/O data are always transmitted on two data lines (DQ0 and DQ1).

Also when in DIO-SPI mode, the device can be driven by a micro controller in either of the two following modes:

- CPOL= 0, CPHA= 0
- CPOL= 1, CPHA= 1

Please refer to the SPI modes for a detailed description of these two modes.

Note: Extended SPI protocol Dual I/O instructions allow only address and data to be transmitted over two data lines. However, DIO-SPI allows instructions, addresses, and data to be transmitted on two data lines.

This mode can be set using two ways

- **Volatile:** by setting bit 6 of the VECR to 0. The device enters DIO-SPI protocol immediately after the Write Enhanced Volatile Configuration Register sequence completes. The device returns to the default working mode (defined by NVCR) on power on.
- **Default/ Non-Volatile:** This is default mode on power-up. By setting bit 2 of the NVCR to 0. The device enters DIO-SPI protocol on the subsequent power-on. After all subsequent power-on sequences, the device still starts in DIO-SPI protocol unless bit 2 of NVCR is set to 1 (default value, corresponding to Extended SPI protocol) or bit 3 of NVCR is set to 0 (corresponding to QIO-SPI protocol).

4.3 Quad SPI (QIO-SPI) protocol

Quad SPI (QIO-SPI) protocol: instructions, addresses, and I/O data are always transmitted on four data lines DQ0, DQ1, \overline{W}/VPP (DQ2), and HOLD / (DQ3).

The exception is the Program/Erase cycle performed with the VPP, in which case the device temporarily goes to Extended SPI protocol. Going temporarily into Extended SPI protocol allows the application either to:

- check the polling bits: WIP bit in the Status Register or Program/Erase Controller bit in the Flag Status Register
- perform Program/Erase suspend functions.

Note: As soon as the VPP pin voltage goes low, the protocol returns to the QIO-SPI protocol.

In QIO-SPI protocol the \overline{W} and HOLD/ (RESET) functionality is disabled when the device is selected (\overline{S} signal low).

When used in the QIO-SPI mode, these devices can be driven by a micro controller in either of the two following modes:

- CPOL=0, CPHA=0
- CPOL=1, CPHA=1

Please refer to the SPI modes for a detailed description of the 2 modes.

Note: In the Extended SPI protocol only Address and data are allowed to be transmitted on 4 data lines, However in QIO-SPI protocol, the address, data and instructions are transmitted across 4 data lines.

This working mode is set in either bit 7 of the Volatile Enhanced Configuration Register (VECR) or in bit 3 of the Non Volatile Configuration Register (NVCR).

This mode can be set using two ways

- **Volatile:** by setting bit 7 of the VECR to 0, the device enters QIO-SPI protocol immediately after the Write Enhanced Volatile Configuration Register sequence completes. The device returns to the default working protocol (defined by the NVCR) on the next power on.
- **Default/ Non- Volatile:** This is default protocol on power up. By setting bit 3 of the NVCR to 0, the device enters QIO-SPI protocol on the subsequent power-on. After all subsequent power-on sequences, the device still starts in QIO-SPI protocol unless bit 3 of the NVCR is set to 1 (default value, corresponding to Extended SPI mode).

5 Operating features

5.1 Extended SPI Protocol Operating features

5.1.1 Read Operations

To read the memory content in Extended SPI protocol different instructions are available: READ, Fast Read, Dual Output Fast Read, Dual Input Output Fast Read, Quad Output Fast Read and Quad Input Output Fast read, allowing the application to choose an instruction to send addresses and receive data by one, two or four data lines.

Note: In the Extended SPI protocol the instruction code is always sent on one data line (DQ0): to use two or four data lines the user must use either the DIO-SPI or the QIO-SPI protocol respectively.

For fast read instructions the number of dummy clock cycles is configurable by using VCR bits [7:4] or NVCR bits [15:12].

After a successful reading instruction a reduced tSHSL equal to 20 ns is allowed to further improve random access time (in all the other cases tSHSL should be at least 50 ns). See [Table 33.: AC Characteristics](#).

5.1.2 Page programming

To program one data byte, two instructions are required: write enable (WREN), which is one byte, and a page program (PP) sequence, which consists of four bytes plus data. This is followed by the internal program cycle (of duration t_{pp}).

To spread this overhead, the page program (PP) instruction allows up to 256 bytes to be programmed at a time (changing bits from '1' to '0'), provided that they lie in consecutive addresses on the same page of memory.

For optimized timings, it is recommended to use the page program (PP) instruction to program all consecutive targeted bytes in a single sequence versus using several page program (PP) sequences with each containing only a few bytes (see [Section 5.2.3: Page programming](#) and [Table 33: AC Characteristics](#)).

5.1.3 Dual input fast program

The dual input fast program (DIFP) instruction makes it possible to program up to 256 bytes using two input pins at the same time (by changing bits from '1' to '0').

For optimized timings, it is recommended to use the DIFP instruction to program all consecutive targeted bytes in a single sequence rather than using several DIFP sequences each containing only a few bytes (see [Section 9.1.12: Dual Input Fast Program \(DIFP\)](#)).

5.1.4 Dual Input Extended Fast Program

The Dual Input Extended Fast Program (DIEFP) instruction is an enhanced version of the Dual Input Fast Program instruction, allowing to transmit address across two data lines.

For optimized timings, it is recommended to use the DIEFP instruction to program all consecutive targeted bytes in a single sequence rather than using several DIEFP sequences, each containing only a few bytes.

5.1.5 Quad Input Fast Program

The Quad Input Fast Program (QIFP) instruction makes it possible to program up to 256 bytes using 4 input pins at the same time (by changing bits from 1 to 0).

For optimized timings, it is recommended to use the QIFP instruction to program all consecutive targeted bytes in a single sequence rather than using several QIFP sequences each containing only a few bytes.

5.1.6 Quad Input Extended Fast Program

The Quad Input Extended Fast Program (QIEFP) instruction is an enhanced version of the Quad Input Fast Program instruction, allowing parallel input on the 4 input pins, including the address being sent to the device.

For optimized timings, it is recommended to use the QIEFP instruction to program all consecutive targeted bytes in a single sequence rather than using several QIEFP sequences each containing only a few bytes.

5.1.7 Subsector erase, sector erase and bulk erase

The page program (PP) instruction allows bits to be reset from '1' to '0'. In order to do this the bytes of memory need to be erased to all 1s (FFh).

This can be achieved as follows:

- a subsector at a time, using the subsector erase (SSE) instruction (only available on the 8 boot sectors at the bottom or top addressable area of a device with a dedicated part number); See [Section 16: Ordering information](#);
- a sector at a time, using the sector erase (SE) instruction;
- throughout the entire memory, using the bulk erase (BE) instruction.

This starts an internal erase cycle (of duration t_{SSE} , t_{SE} or t_{BE}). The erase instruction must be preceded by a write enable (WREN) instruction.

5.1.8 Polling during a write, program or erase cycle

A further improvement in the time to Write Status Register (WRSR), POTP, PP, DIFP, DIEFP, QIFP, QIEFP or Erase (SSE, SE or BE) can be achieved by not waiting for the worst case delay (t_W , t_{PP} , t_{SSE} , t_{SE} , or t_{BE}). The application program can monitor if the required internal operation is completed, by polling the dedicated register bits to establish when the previous Write, Program or Erase cycle is complete.

The information on the memory being in progress for a Program, Erase, or Write instruction can be checked either on the Write In Progress (WIP) bit of the Status Register or in the Program/Erase Controller bit of the Flag Status Register.

Note: The Program/Erase Controller bit is the opposite state of the WIP bit in the Status Register.

In the Flag Status Register additional information can be checked, as eventual Program/Erase failures by mean of the Program or erase Error bits.

5.1.9 Active power and standby power modes

When Chip Select (\bar{S}) is Low, the device is selected, and in the active power mode.

When Chip Select (\overline{S}) is High, the device is deselected, but could remain in the active power mode until all internal cycles have completed (program, erase, write status register). The device then goes in to the standby power mode. The device consumption drops to I_{CC1} .

5.1.10 Hold (or Reset) condition

The Hold (\overline{HOLD}) signal is used to pause serial communications with the device without resetting the clocking sequence. However, taking this signal Low does not terminate any write status register, program or erase cycle that is currently in progress.

To enter the hold condition, the device must be selected, with Chip Select (\overline{S}) Low.

The hold condition starts on the falling edge of the Hold (\overline{HOLD}) signal, provided that the Serial Clock (C) is Low (as shown in [Figure 7](#)).

The hold condition ends on the rising edge of the Hold (\overline{HOLD}) signal, provided that the Serial Clock (C) is Low.

If the falling edge does not coincide with Serial Clock (C) being Low, the hold condition starts after Serial Clock (C) next goes Low. Similarly, if the rising edge does not coincide with Serial Clock (C) being Low, the hold condition ends after Serial Clock (C) next goes Low (this is shown in [Figure 7](#)).

During the hold condition, the serial data output (DQ1) is high impedance, and serial data input (DQ0) and Serial Clock (C) are don't care.

Normally, the device is kept selected, with Chip Select (\overline{S}) driven Low for the whole duration of the hold condition. This is to ensure that the state of the internal logic remains unchanged from the moment of entering the hold condition.

If Chip Select (\overline{S}) goes High while the device is in the Hold condition, this has the effect of resetting the internal logic of the device. To restart communication with the device, it is necessary to drive Hold (\overline{HOLD}) High, and then to drive Chip Select (\overline{S}) Low. This prevents the device from going back to the hold condition.

Figure 7. Hold condition activation

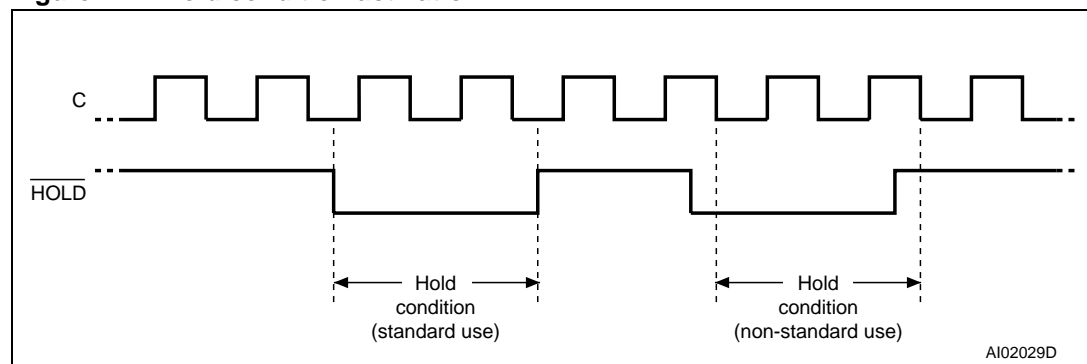

Reset functionality is available instead of Hold in parts with a dedicated part number. See [Section 16: Ordering information](#).

Driving Reset (\overline{Reset}) Low while an internal operation is in progress will affect this operation (write, program or erase cycle) and data may be lost. On Reset going Low, the device enters the reset mode and a time of t_{RHSL} is then required before the device can be reselected by driving Chip Select (\overline{S}) Low. For the value of t_{RHSL} , see [Table 33.: AC Characteristics](#). All the lock bits are reset to 0 after a Reset Low pulse.

Table 2. Device Status after $\overline{\text{Reset}}$ Low Pulse

Conditions: reset pulse occurred	Lock bits status	Internal logic status	Addressed data
While decoding an instruction ⁽¹⁾ : WREN, WRDI, RDID, RDSR, READ, RDLR, Fast_Read, DOFR, DIOFR, QOFR, QIOFR, WRLR, PW, PP, PE, SE, BE, SSE, DP, RDP	Reset to 0	Same as POR ⁽²⁾	Not significant
Under completion of an Erase or Program cycle of a PW, PP, DIFP, DIEFP, SSE, SE, BE operation	Reset to 0	Equivalent to POR ⁽²⁾	Addressed data could be modified
Under completion of a WRSR operation	Reset to 0	Equivalent to POR (after tW)	Write is correctly completed
Device deselected (S High) and in standby mode	Reset to 0	Same as POR ⁽²⁾	Not significant

Note: 1 $\overline{\text{S}}$ remains Low while Reset is Low.

2 See [11: Power-up and power-down](#)

The $\overline{\text{Hold/Reset}}$ feature is not available when the $\overline{\text{Hold (Reset)}}$ / DQ3 pin is used as I/O (DQ3 functionality) during Quad Instructions: QOFR, QIOFR, QIFP and QIEFP.

The $\overline{\text{Hold/Reset}}$ feature can be disabled by using of the bit 4 of the VECR.

5.2 Dual SPI (DIO-SPI) Protocol

In the Dual SPI (DIO-SPI) protocol all the instructions, addresses and I/O data are transmitted on two data lines. All the functionality available in the Extended SPI protocol is also available in the DIO-SPI protocol. The DIO-SPI instructions are comparable with the Extended SPI instructions; however, in DIO-SPI, the instructions are multiplexed on the two data lines, DQ0 and DQ1.

The only exceptions are the READ, Quad Read, and Program instructions, which are not available in DIO-SPI protocol, and the RDID instruction, which is replaced in the DIO-SPI protocol by the Multiple I/O Read Identification (MIORDID) instruction.

The Multiple I/O Read Identification Instruction reads just the standard SPI electronic ID (3 bytes), while the Extended SPI protocol RDID instruction allows access to the UID bytes.

To help the application code port from Extended SPI to DIO-SPI protocol, the instructions available in the DIO-SPI protocol have the same operation code as the Extended SPI protocol, the only exception being the MIORDID instruction.

5.2.1 Multiple Read Identification

The Multiple I/O Read Identification (MIORDID) instruction is available to read the device electronic ID. With respect to the RDID instruction of the Extended SPI protocol, the output data, shifted out on the 2 data lines DQ0 and DQ1.

Since the read ID instruction in the DIO-SPI protocol is limited to 3 bytes of the standard electronic ID, the UID bytes are not read with the MIORDID instruction

5.2.2 Dual Command Fast reading

Reading the memory data multiplexing the instruction, the addresses and the output data on 2 data lines can be achieved in DIO-SPI protocol by mean of the Dual Command Fast Read instruction, that has 3 instruction codes (BBh, 3Bh and 0Bh) to help the application code porting from Extended SPI protocol to DIO-SPI protocol. Of course quad and single I/O Read instructions are not available in DIO-SPI mode.

For Dual Command fast read instructions the number of dummy clock cycles is configurable by using VCR bits [7:4] or NVCR bits [15:12].

After a successful reading instruction, a reduced tSHSL equal to 20ns is allowed to further improve random access time (in all the other cases tSHSL should be at least 50 ns). See [Table 33.: AC Characteristics](#).

5.2.3 Page programming

Programming the memory by transmitting the instruction, addresses and the output data on 2 data lines can be achieved in DIO-SPI protocol by using the Dual Command Page Program instruction, that has 3 instruction codes (D2h, A2h and 02h) to help port from Extended SPI protocol to DIO-SPI protocol

Quad and single input Program instructions are not available in DIO-SPI mode.

The DIO-SPI protocol is similar to the Extended SPI protocol i.e., to program one data byte two instructions are required:

- Write Enable (WREN), which is one byte, and a
- Dual Command Page Program (DCPP) sequence, which consists of four bytes plus data.

This is followed by the internal Program cycle (of duration tPP).

To spread this overhead, the Dual Command Page Program (DCPP) instruction allows up to 256 bytes to be programmed at a time (changing bits from 1 to 0), provided that they are consecutive addresses on the same page of memory.

For optimized timings, it is recommended to use the DCPP instruction to program all consecutive targeted bytes in a single sequence versus using several DCPP sequences with each containing only a few bytes. See [Table 33.: AC Characteristics](#).

5.2.4 Subsector Erase, Sector Erase and Bulk Erase

Similar to the Extended SPI protocol, in the DIO-SPI protocol to erase the memory bytes to all 1s (FFh) the Subsector Erase (SSE), the Sector Erase (SE) and the Bulk Erase (BE) instructions are available. These instructions start an internal Erase cycle (of duration tSSE, tSE or tBE).

The Erase instruction must be preceded by a Write Enable (WREN) instruction.

Subsector Erase is only available on the 8 Bottom (Top) boot sectors, and is not available in uniform architecture parts

5.2.5 Polling during a Write, Program or Erase cycle

Similar to the Extended SPI protocol, in the DIO-SPI protocol it is possible to monitor if the internal write, program or erase operation is completed, by polling the dedicated register bits by using the Read Status Register (RDSR) or Read Flag Status Register (RFSR) instructions, the only obvious difference is that instruction codes, addresses and output data are transmitted across two data lines.

5.2.6 Read and Modify registers

Similar to the Extended SPI protocol, the only obvious difference is that instruction codes, addresses and output data are transmitted across two data lines

5.2.7 Active Power and Standby Power modes

Similar to the Extended SPI protocol, when Chip Select (\overline{S}) is Low, the device is selected, and in the Active Power mode. When Chip Select (\overline{S}) is High, the device is deselected, but could remain in the Active Power mode until all internal cycles have completed (Program, Erase, Write Cycles). The device then goes in to the Standby Power mode. The device consumption drops to ICC1.

5.2.8 HOLD (or Reset) condition

The \overline{HOLD} (or \overline{Reset} i.e. for parts having the reset functionality instead of \overline{hold} pin) signal has exactly the same behavior in DIO-SPI protocol as do in Extended SPI protocol, so please refer to section 5.1.10, "Hold (or Reset) condition" in the Extend SPI protocol section for further details.

5.3 Quad SPI (QIO-SPI) Protocol

In the Quad SPI (QIO-SPI) protocol all the Instructions, addresses and I/O data are transmitted on four data lines, with the exception of the polling instructions performed during a Program or Erase cycle performed with VPP, in this case the device temporarily goes in Extended SPI protocol. The protocol again becomes QIO-SPI as soon as the VPP voltage goes low.

All the functionality available in the Extended SPI protocol are also available in the QIO-SPI mode, with equivalent instruction transmitted on the 4 data lines DQ0, DQ1, DQ2 and DQ3. The exceptions are the READ, Dual Read and Dual Program instructions, that are not available in QIO-SPI protocol, and the RDID instruction, that is replaced in the QIO-SPI protocol by the Multiple I/O Read Identification (MIORDID) instruction. The Multiple I/O Read Instruction reads just the standard SPI electronic ID (3 bytes), while with the Extended SPI protocol RDID instruction is possible to access also the UID bytes.

To help the application code port from Extended SPI to QIO-SPI protocol, the instructions available in the QIO-SPI protocol have the same operation code as in the Extended SPI protocol, the only exception is the MIORDID instruction.

5.3.1 Multiple Read Identification

The Multiple I/O Read Identification (MIORDID) instruction is available to read the device electronic ID. With respect to the RDID instruction of the Extended SPI protocol, the output data, shifted out on the 4 data lines DQ0, DQ1, DQ2 and DQ3.

Since in the QIO-SPI protocol the Read ID instruction is limited to 3 bytes of the standard electronic ID, the UID bytes are not read with the MIORDID instruction.

5.3.2 Quad Command Fast reading

The Array Data can be read by the Quad Command Fast Read instruction using 3 instructions (EBh, 6Bh and 0Bh) to help the application code port from Extended SPI protocol to QIO-SPI protocol. The instruction, address and output data are transmitted across 4 data lines.

The Dual and Single I/O Read instructions are not available in QIO-SPI protocol.

5.3.3 QUAD Command Page programming

The memory can be programmed in QIO-SPI protocol by the Quad Command Page Program instruction using (02h, 12h and 32h). The instruction, address and input data are transmitted across 4 data lines

The Dual and Single I/O Program instructions are not available in QIO-SPI protocol

Programming the memory by multiplexing the instruction, the addresses and the output data on 4 wires can be achieved in QIO-SPI protocol by mean of the Quad Command Page Program instruction, that has 3 instruction codes (02h, 12h and 32h) to help the application code porting from Extended SPI protocol to QIO-SPI protocol.

Similar to the Extended SPI protocol in the QIO-SPI protocol, to program one data byte two instructions are required:

- Write Enable (WREN), which is one byte, and
- Quad Command Page Program (QCPP) sequence, which consists of instruction (one byte), address (3 bytes) and input data.

This is followed by the internal Program cycle (of duration tPP).

To spread this overhead, the Quad Command Page Program (QCPP) instruction allows up to 256 bytes to be programmed at a time (changing bits from 1 to 0), provided that they are in consecutive addresses on the same page of memory.

For optimized timings, it is recommended to use the QCPP instruction to program all consecutive targeted bytes in a single sequence versus using several QCPP sequences with each containing only a few bytes. See [Table 33.: AC Characteristics](#).

The QCPP instruction is transmitted across 4 data lines except when VPP is raised to VPPH.

The VPP can be raised to VPPH to decrease programming time (provided that the bit 3 of the VECR has been set to 0 in advance). When bit 3 of VECR is set to 0 after the Quad Command Page Program instruction sequence has been received, the memory temporarily goes in Extended SPI protocol, and is possible to perform polling instructions (checking the WIP bit of the Status Register or the Program/Erase Controller bit of the Flag Status Register) or Program/Erase Suspend instruction even if DQ2 is temporarily used in this VPP functionality. The memory automatically comes back in QIO-SPI protocol as soon as the VPP pin goes Low.

5.3.4 Subsector Erase, Sector Erase and Bulk Erase

Similar to the Extended SPI protocol, Subsector Erase (SSE)(1), the Sector Erase (SE) and the Bulk Erase (BE) instructions are used to erase the memory in the QIO-SPI protocol. These instructions start an internal Erase cycle (of duration tSSE, tSE or tBE).

The Erase instruction must be preceded by a Write Enable (WREN) instruction.

The erase instructions are transmitted across 4 data lines unless the VPP is raised to VPPH.

The VPP can be raised to VPPH to decrease erasing time, provided that the bit 3 of the VECR has been set to 0 in advance. In this case, after the erase instruction sequence has been received, the memory temporarily goes in extended SPI protocol, and it is possible to perform polling instructions (checking the WIP bit of the Status Register or the Program/Erase Controller bit of the Flag Status Register) or Program/Erase Suspend instruction even if DQ2 is temporarily used in this VPP functionality. The memory automatically comes back in QIO-SPI protocol as soon as the VPP pin goes Low.

Note: Subsector Erase is only available on the 8 Bottom (Top) boot sectors, and is not available in uniform architecture parts

5.3.5 Polling during a Write, Program or Erase cycle

It is possible to check if the internal write, program or erase operation is completed, by polling the dedicated register bits of the Read Status Register (RDSR) or Read Flag Status Register (FSR).

When the Program or Erase cycle is performed with the VPP, the device temporarily goes in single I/O SPI mode. The protocol became again QIO-SPI as soon as the VPP pin voltage goes low.

5.3.6 Read and Modify registers

The read and modify register instructions are available and behave in QIO-SPI protocol exactly as they do in Extended SPI protocol, the only difference is that instruction codes, addresses and output data are transmitted across 4 data lines.

5.3.7 Active Power and Standby Power modes

Exactly as in Extended SPI protocol, when Chip Select (\overline{S}) is Low, the device is selected, and in the Active Power mode. When Chip Select (\overline{S}) is High, the device is deselected, but could remain in the Active Power mode until all internal (Program, Erase, Write) Cycles have completed. The device then goes in to the Standby Power mode. The device consumption drops to ICC1.

5.3.8 HOLD (or Reset) condition

The HOLD (\overline{Hold}) feature (or Reset feature, for parts having the reset functionality instead of hold) is disabled in QIO-SPI protocol when the device is selected: the Hold (or Reset)/ DQ3 pin always behaves as an I/O pin (DQ3 function) when the device is deselected. For parts with reset functionality, it is still possible to reset the memory when it is deselected (C signal high).

5.3.9 VPP pin Enhanced Supply Voltage feature

It is possible in the QIO-SPI protocol to use the VPP pin as an enhanced supply voltage, but the intention to use VPP as accelerated supply voltage must be declared by setting bit 3 of the VECR to 0.

In this case, to accelerate the Program cycle the VPP pin must be raised to VPPH after the device has received the last data to be programmed within 200ms. If the VPP is not raised within 200ms, the program operation starts with the standard internal cycle speed as if the Vpp high voltage were not used, and a flag error appears on Flag Status Register bit 3".

6 Volatile and Non Volatile Registers

The device features many different registers to store, in volatile or non volatile mode, many parameters and operating configurations:

- Legacy SPI Status Register
- 3 configuration registers:
 - Non Volatile Configuration Register (NVCR), 16 bits
 - Volatile Configuration Register (VCR), 8 bits
 - Volatile Enhanced Configuration Register (VECR), 8 bits

The Non Volatile Configuration Register (NVCR) affects the memory configuration starting from the successive power-on. It can be used to make the memory start in a determined condition.

The VCR and VECR affect the memory configuration after every execution of the related Write Volatile configuration Register (WRVCR) and Write Enhanced Volatile Configuration register (WRVECR) instructions. These instructions overwrite the memory configuration set at POR by NVCR.

As described in [Figure 8.: Non Volatile and Volatile configuration Register Scheme](#), the working condition of the memory is set by an internal configuration register, which is not accessible by the user. The working parameters of the internal configuration register are loaded from the NVCR during the boot phase of the device. In this sense the NVCR can be seen as having the default settings of the memory.

During the normal life of the application, every time a write volatile or enhanced volatile configuration register instruction is performed, the new configuration parameters set in the volatile registers are also copied in the internal configuration register, thus instantly affecting the memory behavior. Please note that on the next power on the memory will start again in the working protocol set by the Non Volatile Register parameters.

Figure 8. Non Volatile and Volatile configuration Register Scheme

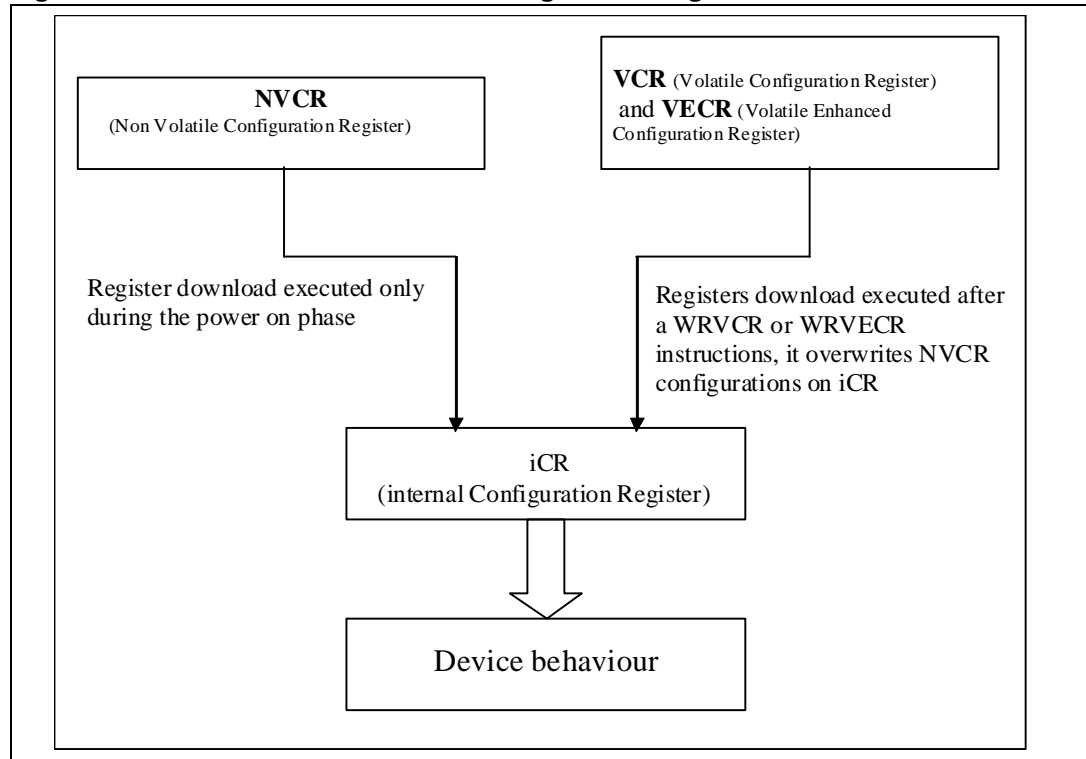

A Flag Status Register (FSR), 8 bits, is also available to check the status of the device, detecting possible errors or a Program/Erase internal cycle in progress.

Each register can be read and modified by means of dedicated instructions in all the 3 protocols (Extended SPI, DIO-SPI, and QIO-SPI).

Reading time for all registers is comparable; writing time instead is very different: NVCR bits are set as Flash Cell memory content requiring a longer time to perform internal writing cycles. See [Table 33.: AC Characteristics](#).

6.1 Legacy SPI Status Register

The Status Register contains a number of status and control bits that can be read or set by specific instructions: Read Status Register (RDSR) and Write Status Register (WRSR). This is available in all the 3 protocols (Extended SPI, DIO-SPI, and QIO-SPI).

Table 3. Status register format

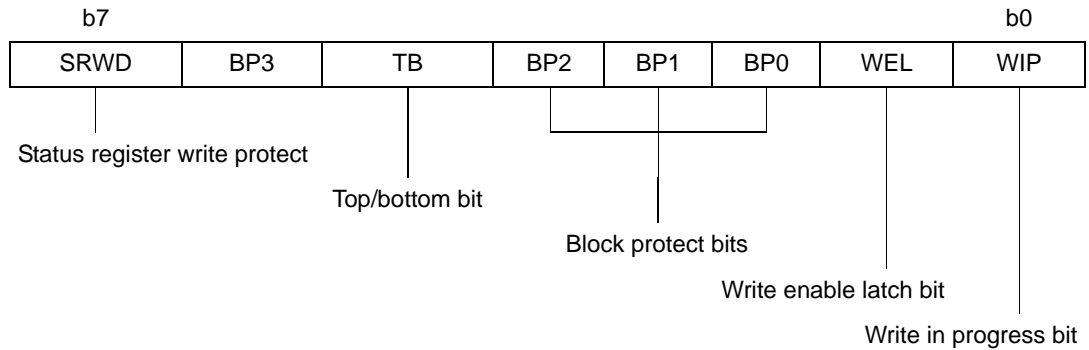

6.1.1 WIP bit

The Write In Progress (WIP) bit set to 1 indicates that the memory is busy with a Write Status Register, Program or Erase cycle. 0 indicates no cycle is in progress.

6.1.2 WEL bit

The Write Enable Latch (WEL) bit set to 1 indicates that the internal Write Enable Latch is set. When set to 0 the internal Write Enable Latch is reset and no Write Status Register, Program or Erase instruction is accepted.

6.1.3 BP3, BP2, BP1, BP0 bits

The Block Protect (BP3, BP2, BP1, BP0) bits are non-volatile. They define the size of the area to be software protected against Program and Erase instructions. These bits are written with the Write Status Register (WRSR) instruction. When one or more of the Block Protect (BP3, BP2, BP1, BP0) bits is set to 1, the relevant memory area, as defined in [Table 10.: Protected area sizes \(TB bit = 0\)](#) and [Table 11.: Protected area sizes \(TB bit = 1\)](#), becomes protected against all program and erase instructions. The Block Protect (BP3, BP2, BP1, BP0) bits can be written provided that the Hardware Protected mode has not been set. The Bulk Erase (BE) instruction is executed if, and only if, all Block Protect (BP3, BP2, BP1, BP0) bits are 0.

6.1.4 TB bit

The Top/Bottom (TB) bit is non-volatile. It can be set and reset with the Write Status Register (WRSR) instruction provided that the Write Enable (WREN) instruction has been issued.

The Top/Bottom (TB) bit is used in conjunction with the Block Protect (BP3, BP2, BP1, BP0) bits to determine if the protected area defined by the Block Protect bits starts from the top or the bottom of the memory array:

- When TB is reset to '0' (default value), the area protected by the Block Protect bits starts from the top of the memory array.
- When TB is set to '1', the area protected by the Block Protect bits starts from the bottom of the memory array.

The TB bit cannot be written when the SRWD bit is set to '1' and the \overline{W} pin is driven Low.

6.1.5 SRWD bit

The Status Register Write Disable (SRWD) bit is operated in conjunction with the Write Protect (\overline{W}/VPP) signal. The Status Register Write Disable (SRWD) bit and the Write Protect (\overline{W}/VPP) signal allow the device to be put in the hardware protected mode (when the Status Register Write Disable (SRWD) bit is set to '1', and Write Protect (\overline{W}/VPP) is driven Low). In this mode, the non-volatile bits of the Status Register (TB, BP3, BP2, BP1, BP0) become read-only bits and the Write Status Register (WRSR) instruction is no longer accepted for execution.

6.2 Non Volatile Configuration Register

The Non Volatile Configuration Register (NVCR) bits affects the default memory configuration after power-on. It can be used to make the memory start in the configuration to fit the application requirements.

The device is delivered with Non Volatile Configuration Register (NVCR) bits all erased to 1 (FFFFh).

The purpose of the NVCR is to define the default memory settings after the power-on sequence related to many features:

- The number of dummy clock cycle for fast read instructions,
- XIP mode configurations,
- output driver strengths,
- fast POR sequence,
- Reset (or Hold) disabling
- Multiple I/O protocol enabling.

The NVCR can be read by the Read Non Volatile Configuration Register (RDNVCR) instruction and written by the Write Non Volatile Configuration Register (WRNVCR) in all the 3 available SPI protocols. See the sections that follow as well as [Table 4.: Non-Volatile Configuration Register](#).

Table 4. Non-Volatile Configuration Register

Bit	Parameter	Value	Description	Note
NVCR<15:12>	Dummy clock cycle	0000	As '1111'	To optimize instruction execution (FASTREAD, DOFR,DIOFR,QOFR, QIOFR, ROTP) according to the frequency
		0001	1	
		0010	2	
		0011	3	
		0100	4	
		0101	5	
		0110	6	
		0111	7	
		1000	8	
		1001	9	
		1010	10	
		1011	11	
		1100	12	
		1101	13	
1110	14			
		1111	Target on maximum allowed frequency f_c (108MHz) and to guarantee backward compatibility (default)	
NVCR<11:9>	XIP enabling at POR	000	XIP for SIO Read	
		001	XIP for DOFR	
		010	XIP for DIOFR	
		011	XIP for QOFR	
		100	XIP for QIOFR	
		101	reserved	
		110	reserved	
		111	XIP disabled (default)	
NVCR<8:6>	Output Driver Strength	000	reserved	Impedance at $V_{cc}/2$
		001	90	
		010	60	
		011	45	
		100	reserved	
		101	20	
		110	15	

Table 4. Non-Volatile Configuration Register

Bit	Parameter	Value	Description	Note
		111	30 (default)	
NVCR<5>	Fast POR x READ	0	Enabled	POR phase < 100us only read available
		1	Disabled (default)	POR phase ~ 700us all instructions available
NVCR<4>	Reset/Hold disable	0	disabled	Disable Pad Hold/Reset functionality
		1	enabled (default)	
NVCR<3>	Quad Input Command	0	enabled	Enable command on four input line
		1	disabled (default)	
NVCR<2>	Dual Input Command	0	enabled	Enable command on two input line
		1	disabled (default)	
NVCR<1:0>	Reserved	xx	Don't care	Default value = "11"

6.2.1 Dummy clock cycle NV configuration bits (NVCR bits from 15 to 12)

The bits from 15 to 12 of the Non Volatile Configuration register store the default settings for the dummy clock cycles number after the fast read instructions (in all the 3 available protocols). The dummy clock cycles number can be set from 1 up to 15 as described here, according to operating frequency (the higher is the operating frequency, the bigger must be the dummy clock cycle number) to optimize the fast read instructions performance.

The default values of these bits allow the memory to be safely used with fast read instructions at the maximum frequency (108 MHz). Please note that if the dummy clock number is not sufficient for the operating frequency, the memory reads wrong data.

Table 5. Maximum allowed frequency (MHz)

Maximum allowed frequency (MHz) ⁽¹⁾					
Dummy Clock	FASTREAD	DOFR	DIOFR	QOFR	QIOFR
1	50	50	39	43	20
2	95	85	59	56	39
3	105	95	75	70	49
4	108	105	88	83	59
5	108	108	94	94	69
6	108	108	105	105	78
7	108	108	108	108	86
8	108	108	108	108	95
9	108	108	108	108	105
10	108	108	108	108	108

1. All values are guaranteed by characterization and not 100% tested in production.

6.2.2 XIP NV configuration bits (NVCR bits from 11 to 9)

The bits from 11 to 9 of the Non Volatile Configuration register store the default settings for the XIP operation, allowing the memory to start working directly on the required XIP mode after successive POR sequence: the device then accepts only address on one, two, or four wires (skipping the instruction) depending on the NVCR XIP bits settings.

The default settings for the XIP bits of the NVCR enable the memory to start working in Extended SPI mode after the POR sequence (XIP directly after POR is disabled).

6.2.3 Output Driver Strength NV configuration bits (NVCR bits from 8 to 6)

The bits from 8 to 6 of the Non Volatile Configuration register store the default settings for the output driver strength, enabling to optimize the impedance at $V_{cc}/2$ output voltage for the specific application.

The default values of Output Driver Strength bits of the NVCR set the output impedance at $V_{cc}/2$ equal to 30 Ohms.

6.2.4 Fast POR NV configuration bit (NVCR bit 5)

The bit 5 of the NVCR enables the FAST POR sequence to speed up the application boot phase before the first READ instruction: if enabled, the FAST POR allows to perform the first read operation after less than 100us. Please note that this timing is valid only for the reading operations: if a modify instruction is then required, after the first WREN instruction the complete POR phase will be performed, resulting in latency time between the WREN and the receiving of the modify instruction (~500us). During this latency time, when the power on second phase is running, no instruction will be accepted except the standard polling instructions either on the Flag Status register or in the Status Register.

The default values of Fast POR bit of the NVCR is set to disable the Fast POR feature, in this case the POR sequence requires the standard value of ~500us and after the first WREN instruction no relevant latency time is needed.

6.2.5 Hold (Reset) disable NV configuration bit (NVCR bit 4)

The Hold (RESET) disable bit can be used to disable the Hold (Reset) functionality of the Hold (Reset) / DQ3 pin as described in [Table 4.: Non-Volatile Configuration Register](#). This feature can be useful to avoid accidental Hold or Reset condition entries in applications that never require the Hold (Reset) functionality.

The default values of Hold (Reset) bit of the NVCR is set to enable the Hold (Reset) functionality.

Note: [Reset functionality is available instead of Hold](#) in devices with a dedicated part number. See [Section 16: Ordering information](#).

6.2.6 Quad Input NV configuration bit (NVCR bit 3)

The Quad Input NV configuration bit can be used to make the memory start working in QIO-SPI protocol directly after the power on sequence. The products are delivered with this set to 1, making the memory default in Extended SPI protocol, if the application sets this bit to 0 the device will enter in QIO-SPI protocol right after the next power on.

Please note that in case both QIO-SPI and DIO-SPI are enabled (both bit 3 and bit 2 of the Non Volatile Configuration Register set to 0), the memory will work in QIO-SPI.

6.2.7 Dual Input NV configuration bit (NVCR bit 2)

The Dual Input NV configuration bit can be used to make the memory start working in DIO-SPI protocol directly after the power on sequence. The products are delivered with this set to 1, making the memory default in Extended SPI protocol, if the application sets this bit to 0 the device will enter in QIO-SPI protocol right after the next power on.

Please note that in case both QIO-SPI and DIO-SPI are enabled (both bit 3 and bit 2 of the Non Volatile Configuration Register set to 0), the memory will work in QIO-SPI.

6.3 Volatile Configuration Register

The Volatile Configuration Register (VCR) affects the memory configuration after every execution of Write Volatile Configuration Register (WRVCR) instruction: this instruction overwrite the memory configuration set at POR by the Non Volatile Configuration Register (NVCR). Its purpose is to define the dummy clock cycles number and to make the device ready to enter in the required XIP mode.

Table 6. Volatile Configuration Register

Bit	Parameter	Value	Description	Note
VCR<7:4>	Dummy clock cycle	0000	As '1111'	To optimize instruction execution (FASTREAD, DOFR,DIOFR,QOFR, QIOFR, ROTP) according to the frequency
		0001	1	
		0010	2	
		0011	3	
		0100	4	
		0101	5	
		0110	6	
		0111	7	
		1000	8	
		1001	9	
		1010	10	
		1011	11	
		1100	12	
		1101	13	
	1110	14		
	1111	Target on maximum allowed frequency fc (108MHz) and to guarantee backward compatibility (default)		
VCR<3>	XIP	0	Ready to enter XIP mode	To make the data on DQ0 during the first dummy clock NOT "Don't Care." For devices with feature set digit equal to 2 or 4 in the part number (Basic XiP), this bit is always Don't Care"
		1	XIP disabled (default)	
VCR<2:0>	Reserved	xxx	reserved	Fixed value = 000b

6.3.1 Dummy clock cycle Volatile Configurations bits (VCR bits from 7 to 4)

The bits from 7 to 4 of the Volatile Configuration Register, as the bits from 15 to 12 of the Volatile Configuration register, set the dummy clock cycles number after the fast read instructions (in all the 3 available protocols). The dummy clock cycles number can be set from 1 up to 15 as described in [Table 6.: Volatile Configuration Register](#), according to operating frequency (the higher is the operating frequency, the bigger must be the dummy clock cycle number, according to [Table 5.: Maximum allowed frequency \(MHz\)](#)) to optimize the fast read instructions performance.

Note: If the dummy clock number is not sufficient for the operating frequency, the memory reads wrong data.

6.3.2 XIP Volatile Configuration bits (VCR bit 3)

The bit 3 of the Volatile Configuration Register is the XIP enabling bit, this bit must be set to 0 to enable the memory working on XIP mode. For devices with a feature set digit equal to 2 or 4 in the part number (Basic XiP), this bit is always Don't Care, and it is possible to operate the memory in XIP mode without setting it to 0. See [Section 16: Ordering information](#).

6.4 Volatile Enhanced Configuration Register

The Volatile Enhanced Configuration Register (VECR) affects the memory configuration after every execution of Write Volatile Enhanced Configuration Register (WRVECR) instruction: this instruction overwrite the memory configuration set during the POR sequence by the Non Volatile Configuration Register (NVCR). Its purpose is:

- enabling of QIO-SPI protocol and DIO-SPI protocol

Warning: WARNING: in case of both QIO-SPI and DIO-SPI enabled, the memory works in QIO-SPI

- HOLD (Reset) functionality disabling
- To enable the VPP functionality in Quad I/O modify operations
- To define output driver strength (3 bit)

Table 7. Volatile Enhanced Configuration Register

Bit	Parameter	Value	Description	Note
VECR<7>	Quad Input Command	0	Enabled	Enable command on four input lines
		1	Disabled (default)	
VECR<6>	Dual Input Command	0	Enabled	Enable command on two input lines
		1	Disabled (default)	
VECR<5>	Reserved	x	Reserved	Fixed value = 0b
VECR<4>	Reset/Hold disable	0	Disabled	Disable Pad Hold/Reset functionality
		1	Enabled (default)	
VECR<3>	Accelerator pin enable in QIO-SPI protocol or in QIFP/QIEFP	0	Enabled	The bit must be considered in case of QIFP, QIEFP, or QIO-SPI protocol. It is "Don't Care" otherwise.
		1	Disabled (default)	
VECR<2:0>	Output Driver Strength	000	reserved	Impedance at $V_{CC}/2$
		001	90	
		010	60	
		011	45	
		100	reserved	
		101	20	
		110	15	
		111	30 (default)	

6.4.1 Quad Input Command VECR<7>

The Quad Input Command configuration bit can be used to make the memory start working in QIO-SPI protocol directly after the Write Volatile Enhanced Configuration Register (WRVECR) instruction. The default value of this bit is 1, corresponding to Extended SPI protocol. If this bit is set to 0 the memory works in QIO-SPI protocol. If VECR bit 7 is set back to 1 the memory start working again in Extended SPI protocol, unless the bit 6 is set to 0 (in this case the memory start working in DIO-SPI mode).

Please note that in case both QIO-SPI and DIO-SPI are enabled (both bit 7 and bit 6 of the VECR set to 0), the memory will work in QIO-SPI.

6.4.2 Dual Input Command VECR<6>

The Dual Input Command configuration bit can be used to make the memory start working in DIO-SPI protocol directly after the Write Volatile Enhanced Configuration Register (WVECR) instruction. The default value of this bit is 1, corresponding to Extended SPI protocol, if this bit is set to 0 the memory works in DIO-SPI protocol (unless the Volatile Enhanced Configuration Register bit 7 is also set to 0). If the Volatile Enhanced Configuration Register bit 6 is set back to 1 the memory start working again in Extended SPI protocol.

Please note that in case both QIO-SPI and DIO-SPI are enabled (both bit 7 and bit 6 of the VECR are set to 0), the memory will work in QIO-SPI.

6.4.3 Reset/Hold disable VECR<4>

The Hold (RESET) disable bit can be used to disable the Hold (Reset) functionality of the Hold (Reset) / DQ3 pin right after the Write Volatile Enhanced Configuration Register (WVECR) instruction. This feature can be useful to avoid accidental Hold or Reset condition entries in applications that never require the Hold (Reset) functionality. If this bit is set to 0 the Hold (Reset) functionality is disabled, it is possible to enable it back by setting this bit to 1.

Please note that after the next power on the Hold (Reset) functionality will be enabled again unless the bit 4 of the Non Volatile Configuration Register is set to 0.

Note: *Reset functionality is available instead of Hold in devices with a dedicated part number. See [Section 16: Ordering information](#).*

6.4.4 Accelerator pin enable: QIO-SPI protocol / QIFP/QIEFP VECR<3>

The bit 3 of the Volatile Enhanced Configuration Register determines whether it is possible to use the Vpp accelerating voltage to speed up the internal modify operation with the Quad program and erase instructions (both in Extended or QIO-SPI protocols).

To use the Vpp voltage with the Quad I/O modify instructions, this bit must be set to 0. The default value is 1, in which case the Vpp pin functionality is disabled in all Quad I/O operations: both in Extended SPI and QIO-SPI protocols.

If the Volatile Enhanced Configuration Register bit 3 is set to 0, using the QIO-SPI protocol, after a Quad Command Page Program instruction or an Erase instruction is received (with all input data in the Program case) and the memory is de-selected, the protocol temporarily switches to Extended SPI protocol until Vpp passes from Vpph to normal I/O value (this transition is mandatory to come back to QIO-SPI protocol), to enable the possibility to perform polling instructions (to check if the internal modify cycle is finished by means of the WIP bit of the Status Register or of the Program/Erase controller bit of the Flag Status register) or Program/Erase Suspend instruction even if the DQ2 pin is temporarily used in his Vpp functionality.

If the Volatile Enhanced Configuration Register bit 3 is set to 0, after any quad modify instruction (both in Extended SPI protocol and QIO-SPI protocol), there is a maximum allowed time-out of 200 ms after the last instruction input is received and the memory is de-selected to raise the Vpp signal to Vpph; otherwise, the modify instruction starts at normal speed, without the Vpph enhancement, and a flag error appears on Flag Status Register bit 3.

6.4.5 Output Driver Strength VECR<2:0>

The bits from 2 to 0 of the VECR set the value of the output driver strength, enabling to optimize the impedance at Vcc/2 output voltage for the specific application as described in [Table 7.: Volatile Enhanced Configuration Register](#).

The default values of Output Driver Strength is set by the dedicated bits of the Non Volatile Configuration Register (NVCR), the parts are delivered with the output impedance at Vcc/2 equal to 30 Ohms.

6.5 Flag Status Register

The Flag Status Register is a powerful tool to investigate the status of the device, checking information regarding what is actually doing the memory and detecting possible error conditions.

The Flag status register is composed by 8 bit. Three bits (Program/Erase Controller bit, Erase Suspend bit and Program Suspend bit) are a "Status Indicator bit", they are set and reset automatically by the memory. Four bits (Erase error bit, Program error bit, VPP 1 to 0 error bit and Protection error bit) are "Error Indicators bits", they are set by the memory when some program or erase operation fails or the user tries to perform a forbidden operation. The user can clear the Error Indicators bits by mean of the Clear Flag Status Register (CLFSR) instruction.

All the Flag Status Register bits can be read by mean of the Read Status Register (RFSR) instruction.

Table 8. Flag Status Register

BIT	Description	Note
7	P/E Controller (not WIP)	Status
6	Erase Suspend	Status
5	Erase	Error
4	Program	Error
3	VPP	Error
2	Program Suspend	Status
1	Protection	Error
0	RESERVED	

6.5.1 P/E Controller Status bit

The bit 7 of the Flag Status register represents the Program/Erase Controller Status bit, It indicates whether there is a Program/Erase internal cycle active. When P/E Controller Status bit is Low (FSR<7>=0) the device is busy; when the bit is High (FSR<7>=1) the device is ready to process a new command.

This bit has the same meaning of Write In Progress (WIP) bit of the standard SPI Status Register, but with opposite logic: FSR<7> = not WIP

It's possible to make the polling instructions, to check if the internal modify operations are finished, both on the Flag Status register bit 7 or on WIP bit of the Status Register.

6.5.2 Erase Suspend Status bit

The bit 6 of the Flag Status register represents the Erase Suspend Status bit, It indicates that an Erase operation has been suspended or is going to be suspended.

The bit is set (FSR<6>=1) within the Erase Suspend Latency time, that is as soon as the Program/Erase Suspend command (PES) has been issued, therefore the device may still complete the operation before entering the Suspend Mode.

The Erase Suspend Status should be considered valid when the P/E Controller bit is high (FSR<7>=1).

When a Program/Erase Resume command (PER) is issued the Erase Suspend Status bit returns Low (FSR<6>=0)

6.5.3 Erase Status bit

The bit 5 of the Flag Status Register represents the Erase Status bit. It indicates an erase failure or a protection error when an erase operation is issued.

When the Erase Status bit is High (FSR<5>=1) after an Erase failure that means that the P/E Controller has applied the maximum pulses number to the portion to be erased and still failed to verify that it has correctly erased.

The Erase Status bit should be read once the P/E Controller Status bit is High.

The Erase Status bit is related to all possible erase operations: Sector Erase, Sub Sector Erase, and Bulk Erase in all the three available protocols (SPI, DIO-SPI and QIO-SPI).

Once the bit 5 is set High, it can only be reset Low (FSR<5>=0) by a Clear Flag Status Register command (CLFSR).

If set High it should be reset before a new Erase command is issued; otherwise the new command will appear to fail.

6.5.4 Program Status bit

The bit 4 of the Flag Status Register represents the Program Status bit. It indicates:

- a Program failure
- an attempt to program a '1' on '0' when VPP=VPPH (only when the pattern is a multiple of 64 bits, otherwise this bit is "Don't care").
- a protection error when a program is issued

When the Program Status bit is High (FSR<4>=1) after a Program failure that means that the P/E Controller has applied the maximum pulses number to the bytes and it still failed to verify that the required data have been correctly programmed.

After an attempt to program '1' on '0', the FSR<4> only goes High (FSR<4>=1) if VPP=VPPH and the data pattern is a multiple of 64 bits: if VPP is not VPPH, FSR<4> remains Low and the attempt is not shown while if VPP is equal to VPPH but the pattern is not a 64 bits multiple the bit 4 is Don't Care. The Program Status bit should be read once the P/E Controller Status bit is High.

The Program Status bit is related to all possible program operations in the Extended SPI protocol: Page Program, Dual and Quad Input Fast Program, Dual and Quad Input Extended Fast Program, and OTP Program.

The Program Status bit is related to the following program operations in the DIO-SPI and QIO-SPI protocols: Dual and Quad Command Page program and OTP program.

Once the bit is set High, it can only be reset Low (FSR<4>=0) by a Clear Flag Status Register command (CLFSR). If set High it should be reset before a new Program command is issued, otherwise the new command will appear to fail.

6.5.5 VPP Status bit

The bit 3 of the Flag Status Register represents the VPP Status bit. It indicates an invalid voltage on the VPP pin during Program and Erase operations. The VPP pin is sampled at the beginning of a Program or Erase operation.

If VPP becomes invalid during an operation, that is the voltage on VPP pin is below the VPPH Voltage (9V), the VPP Status bit goes High (FSR<3>=1) and indeterminate results can occur.

Once set High, the VPP Status bit can only be reset Low (FSR<3>=0) by a Clear Flag Status Register command (CLFSR). If set High it should be reset before a new Program or Erase command is issued, otherwise the new command will appear to fail.

6.5.6 Program Suspend Status bit

The bit 2 of the Flag Status register represents the Program Suspend Status bit, It indicates that an Program operation has been suspended or is going to be suspended.

The bit is set (FSR<2>=1) within the Erase Suspend Latency time, that is as soon as the Program/Erase Suspend command (PES) has been issued, therefore the device may still complete the operation before entering the Suspend Mode.

The Program Suspend Status should be considered valid when the P/E Controller bit is high (FSR<7>=1).

When a Program/Erase Resume command (PER) is issued the Program Suspend Status bit returns Low (FSR<2>=0)

6.5.7 Protection Status bit

The bit 1 of the Flag Status Register represents the Protection Status bit. It indicates that an Erase or Program operation has tried to modify the contents of a protected array sector, or that a modify operation has tried to access to a locked OTP space. The Protection Status bit is related to all possible protection violations as follows:

- The sector is protected by Software Protection Mode 1 (SPM1) Lock registers,
- The sector is protected by Software Protection Mode 2 (SPM2) Block Protect Bits (standard SPI Status Register),
- An attempt to program OTP when locked,
- A Write Status Register command (WRSR) on STD SPI Status Register when locked by the SRWD bit in conjunction with the Write Protect (\bar{W}/VPP) signal (Hardware Protection Mode).

Once set High, the Protection Status bit can only be reset Low (FSR<1>=0) by a Clear Flag Status Register command (CLFSR). If set High it should be reset before a new command is issued, otherwise the new command will appear to fail.

7 Protection modes

There are protocol-related and specific hardware and software protection modes. They are described below.

7.1 SPI Protocol-related protections

This applies to all three protocols. The environments where non-volatile memory devices are used can be very noisy. No SPI device can operate correctly in the presence of excessive noise. To help combat this, the N25Q128 features the following data protection mechanisms:

- Power On Reset and an internal timer (tPUW) can provide protection against inadvertent changes while the power supply is outside the operating specification.
- Program, Erase, and Write Status Register instructions are checked to ensure the instruction includes a number of clock pulses that is a multiple of a byte before they are accepted for execution.
- All instructions that modify data must be preceded by a Write Enable (WREN) instruction to set the Write Enable Latch (WEL) bit. This bit is returned to its reset state by the following events (in Extended SPI protocol mode):
 - Power-up
 - Write Disable (WRDI) instruction completion
 - Write Status Register (WRSR) instruction completion
 - Write to Lock Register (WRLR) instruction completion
 - Program OTP (POTP) instruction completion
 - Page Program (PP) instruction completion
 - Dual Input Fast Program (DIFP) instruction completion
 - Dual Input Extended Fast Program (DIEFP) instruction completion
 - Quad Input Fast Program (QIFP) instruction completion
 - Quad Input Extended Fast Program (QIEFP) instruction completion
 - Subsector Erase (SSE) instruction completion
 - Sector Erase (SE) instruction completion
 - Bulk Erase (BE) instruction completion

This bit is also returned to its reset state after all the analogous events in DIO-SPI and QIO-SPI protocol modes.

7.2 Specific hardware and software protection

There are two software protected modes, SPM1 and SPM2, that can be combined to protect the memory array as required. The SPM2 can be locked by hardware with the help of the \overline{W} input pin.

SPM1

The first software protected mode (SPM1) is managed by specific Lock Registers assigned to each 64 Kbyte sector.

The Lock Registers can be read and written using the Read Lock Register (RDLR) and Write to Lock Register (WRLR) instructions.

In each Lock Register two bits control the protection of each sector: the Write Lock bit and the Lock Down bit.

- **Write Lock bit:** The Write Lock bit determines whether the contents of the sector can be modified (using the Write, Program, or Erase instructions). When the Write Lock bit is set to '1', the sector is write protected - any operations that attempt to change the data in the sector will fail. When the Write Lock bit is reset to '0', the sector is not write protected by the Lock Register, and may be modified.
- **Lock Down bit:** The Lock Down bit provides a mechanism for protecting software data from simple hacking and malicious attack. When the Lock Down bit is set to '1', further modification to the Write Lock and Lock Down bits cannot be performed. A powerup is required before changes to these bits can be made. When the Lock Down bit is reset to '0', the Write Lock and Lock Down bits can be changed.

The definition of the Lock Register bits is given in Table 9: Lock Register out.

SPM2

The second software protected mode (SPM2) uses the Block Protect bits (BP3, BP2, BP1, BP0) and the Top/Bottom bit (TB bit) to allow part of the memory to be configured as read-only. See [Section 16: Ordering information](#).

Table 9. Software protection truth table (Sectors 0 to 255, 64 Kbyte)

Sector Lock Register		Protection Status
Lock Down bit	Write Lock bit	
0	0	Sector unprotected from Program/Erase/Write operations, protection status reversible.
0	1	Sector protected from Program/Erase/Write operations, protection status reversible.
1	0	Sector unprotected from Program/Erase/Write operations. Sector protection status cannot be changed except by a power-up.
1	1	Sector protected from Program/Erase/Write operations. Sector protection status cannot be changed except by a power-up.

As a second level of protection, the Write Protect signal (applied on the \overline{W}/VPP pin) can freeze the Status Register in a read-only mode. In this mode, the Block Protect bits (BP3, BP2, BP1, BP0) and the Status Register Write Disable bit (SRWD) are protected.

Table 10. Protected area sizes (TB bit = 0)

Status Register Content					Memory Content	
TB bit	BP3 Bit	BP2 Bit	BP1 Bit	BP0 Bit	Protected Area	Unprotected Area
0	0	0	0	0	None	All sectors (sectors 0 to 255)
0	0	0	0	1	Upper 256th (1/2 Mbit, sector 255)	Sectors 0 to 254
0	0	0	1	0	Upper 128th (1 Mbit, 2 sectors: 254 to 255)	Sectors 0 to 253
0	0	0	1	1	Upper 64th (2 Mbit, 4 sectors: 252 to 255)	Sectors 0 to 251
0	0	1	0	0	Upper 32nd (4 Mbit, 8 sectors: 248 to 255)	Sectors 0 to 247
0	0	1	0	1	Upper 16th (8 Mbit, 16 sectors: 240 to 255)	Sectors 0 to 239
0	0	1	1	0	Upper 8th (16 Mbit, 32 sectors: 224 to 255)	Sectors 0 to 223
0	0	1	1	1	Upper quarter (32 Mbit, 64 sectors: 193 to 255)	Lower 3 quarters (sectors 0 to 191)
0	1	0	0	0	Upper half (64 Mbit, 128 sectors: 128 to 255)	Lower half (sectors 0 to 127)
0	1	0	0	1	All sectors (128 Mbit, 256 sectors)	None
0	1	0	1	0	All sectors (128 Mbit, 256 sectors)	None
0	1	0	1	1	All sectors (128 Mbit, 256 sectors)	None
0	1	1	0	0	All sectors (128 Mbit, 256 sectors)	None
0	1	1	0	1	All sectors (128 Mbit, 256 sectors)	None
0	1	1	1	0	All sectors (128 Mbit, 256 sectors)	None
0	1	1	1	1	All sectors (128 Mbit, 256 sectors)	None

Table 11. Protected area sizes (TB bit = 1)

Status Register Content					Memory Content	
TB bit	BP3 Bit	BP2 Bit	BP1 Bit	BP0 Bit	Protected Area	Unprotected Area
1	0	0	0	0	None	All sectors (sectors 0 to 255)
1	0	0	0	1	Lower 256th (1/2 Mbit, sector 0)	Sectors 1 to 255
1	0	0	1	0	Lower 128th (1 Mbit, 2 sectors: 0 to 1)	Sectors 2 to 255
1	0	0	1	1	Lower 64th (2 Mbit, 4 sectors: 0 to 3)	Sectors 4 to 255
1	0	1	0	0	Lower 32nd (4 Mbit, 8 sectors: 0 to 7)	Sectors 8 to 255
1	0	1	0	1	Lower 16th (8 Mbit, 16 sectors: 0 to 15)	Sectors 16 to 255
1	0	1	1	0	Lower 8th (16 Mbit, 32 sectors: 0 to 31)	Sectors 33 to 255
1	0	1	1	1	Lower quarter (32 Mbit, 64 sectors: 0 to 63)	Upper 3 quarters (sectors 64 to 255)
1	1	0	0	0	Lower half (64 Mbit, 128 sectors: 0 to 127)	Upper half (sectors 128 to 255)
1	1	0	0	1	All sectors (128 Mbit, 256 sectors)	None
1	1	0	1	0	All sectors (128 Mbit, 256 sectors)	None
1	1	0	1	1	All sectors (128 Mbit, 256 sectors)	None
1	1	1	0	0	All sectors (128 Mbit, 256 sectors)	None
1	1	1	0	1	All sectors (128 Mbit, 256 sectors)	None
1	1	1	1	0	All sectors (128 Mbit, 256 sectors)	None
1	1	1	1	1	All sectors (128 Mbit, 256 sectors)	None

The N25Q128 is available in the following architecture versions:

- Bottom version, 64 KB uniform sectors plus 8 bottom boot sectors (each with 16 subsectors),
- Top version, 64 KB uniform sectors plus 8 top boot sectors (each with 16 subsectors)
- Uniform version, 64 KB uniform sectors without any boot sectors and subsectors.

8 Memory organization

The memory is organized as:

- 16,777,216 bytes (8 bits each)
- 256 sectors (64 Kbytes each)
- In Bottom and Top versions: 8 bottom (top) 64 Kbytes boot sectors with 16 subsectors (4 Kbytes) and 248 standard 64 KB sectors
- 65,536 pages (256 bytes each)
- 64 OTP bytes located outside the main memory array

Each page can be individually programmed (bits are programmed from 1 to 0). The device is Sector or Bulk Erasable (bits are erased from 0 to 1) but not Page Erasable, Subsector Erase is allowed on the 8 boot sectors (for devices with bottom or top architecture).

Figure 9. Block diagram

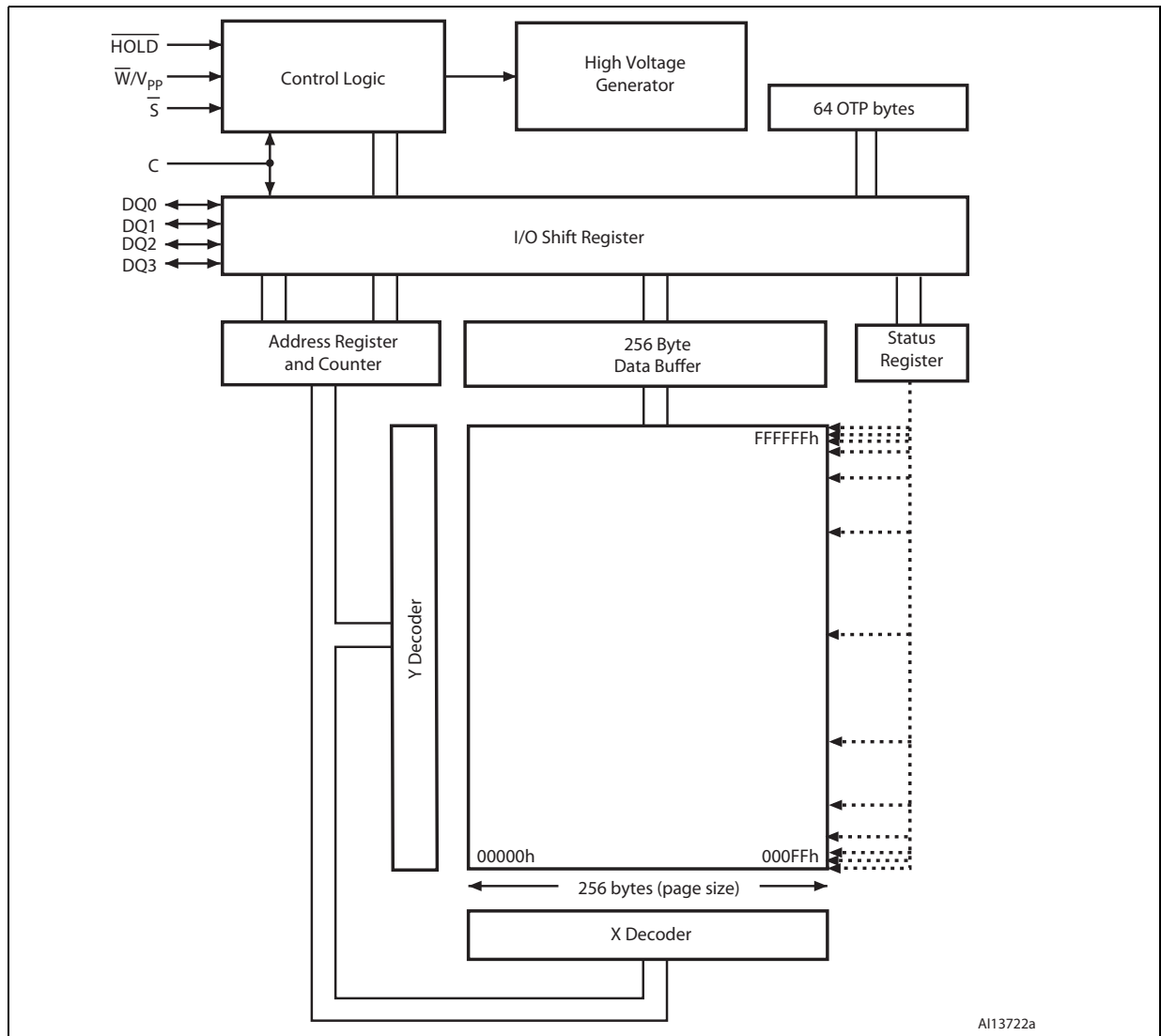

Table 12. Memory organization (uniform) (page 1 of 8)

Sector	Address range	
255	FF0000	FFFFFF
254	FE0000	FEFFFF
253	FD0000	FDFFFF
252	FC0000	FCFFFF
251	FB0000	FBFFFF
250	FA0000	FAFFFF
249	F90000	F9FFFF
248	F80000	F8FFFF
247	F70000	F7FFFF
246	F60000	F6FFFF
245	F50000	F5FFFF
244	F40000	F4FFFF
243	F30000	F3FFFF
242	F20000	F2FFFF
241	F10000	F1FFFF
240	F00000	F0FFFF
239	EF0000	EFFFFF
238	EE0000	EEFFFF
237	ED0000	EDFFFF
236	EC0000	ECFFFF
235	EB0000	EBFFFF
234	EA0000	EAFFFF
233	E90000	E9FFFF
232	E80000	E8FFFF
231	E70000	E7FFFF
230	E60000	E6FFFF
229	E50000	E5FFFF
228	E40000	E4FFFF
227	E30000	E3FFFF
226	E20000	E2FFFF
225	E10000	E1FFFF
224	E00000	E0FFFF
223	DF0000	DFFFFF
222	DE0000	DEFFFF

Table 12. Memory organization (uniform) (page 2 of 8)

Sector	Address range	
221	DD0000	DDFFFF
220	DC0000	DCFFFF
219	DB0000	DBFFFF
218	DA0000	DAFFFF
217	D90000	D9FFFF
216	D80000	D8FFFF
215	D70000	D7FFFF
214	D60000	D6FFFF
213	D50000	D5FFFF
212	D40000	D4FFFF
211	D30000	D3FFFF
210	D20000	D2FFFF
209	D10000	D1FFFF
208	D00000	D0FFFF
207	CF0000	CEFFFF
206	CE0000	CEFFFF
205	CD0000	CDFFFF
204	CC0000	CCFFFF
203	CB0000	CBFFFF
202	CA0000	CAFFFF
201	C90000	C9FFFF
200	C80000	C8FFFF
199	C70000	C7FFFF
198	C60000	C6FFFF
197	C50000	C5FFFF
196	C40000	C4FFFF
195	C30000	C3FFFF
194	C20000	C2FFFF
193	C10000	C1FFFF
192	C00000	C0FFFF
191	BF0000	BEFFFF
190	BE0000	BEFFFF
189	BD0000	BDFFFF
188	BC0000	BCFFFF
187	BB0000	BBFFFF

Table 12. Memory organization (uniform) (page 3 of 8)

Sector	Address range	
	186	BA0000
185	B90000	B9FFFF
184	B80000	B8FFFF
183	B70000	B7FFFF
182	B60000	B6FFFF
181	B50000	B5FFFF
180	B40000	B4FFFF
179	B30000	B3FFFF
178	B20000	B2FFFF
177	B10000	B1FFFF
176	B00000	B0FFFF
175	AF0000	AFFFFF
174	AE0000	AEFFFF
173	AD0000	ADFFFF
172	AC0000	ACFFFF
171	AB0000	ABFFFF
170	AA0000	AAFFFF
169	A90000	A9FFFF
168	A80000	A8FFFF
167	A70000	A7FFFF
166	A60000	A6FFFF
165	A50000	A5FFFF
164	A40000	A4FFFF
163	A30000	A3FFFF
162	A20000	A2FFFF
161	A10000	A1FFFF
160	A00000	A0FFFF
159	9F0000	9FFFFF
158	9E0000	9EFFFF
157	9D0000	9DFFFF
156	9C0000	9CFFFF
155	9B0000	9BFFFF
154	9A0000	9AFFFF
153	990000	99FFFF
152	980000	98FFFF

Table 12. Memory organization (uniform) (page 4 of 8)

Sector	Address range	
151	970000	97FFFF
150	960000	96FFFF
149	950000	95FFFF
148	940000	94FFFF
147	930000	93FFFF
146	920000	92FFFF
145	910000	91FFFF
144	900000	90FFFF
143	8F0000	8FFFFF
142	8E0000	8EFFFF
141	8D0000	8DFFFF
140	8C0000	8CFFFF
139	8B0000	8BFFFF
138	8A0000	8AFFFF
137	890000	89FFFF
136	880000	88FFFF
135	870000	87FFFF
134	860000	86FFFF
133	850000	85FFFF
132	840000	84FFFF
131	830000	83FFFF
130	820000	82FFFF
129	810000	81FFFF
128	800000	80FFFF
127	7F0000	7FFFFF
126	7E0000	7EFFFF
125	7D0000	7DFFFF
124	7C0000	7CFFFF
123	7B0000	7BFFFF
122	7A0000	7AFFFF
121	790000	79FFFF
120	780000	78FFFF
119	770000	77FFFF
118	760000	76FFFF
117	750000	75FFFF

Table 12. Memory organization (uniform) (page 5 of 8)

Sector	Address range	
	116	740000
115	730000	73FFFF
114	720000	72FFFF
113	710000	71FFFF
112	700000	70FFFF
111	6F0000	6FFFFF
110	6E0000	6EFFFF
109	6D0000	6DFFFF
108	6C0000	6CFFFF
107	6B0000	6BFFFF
106	6A0000	6AFFFF
105	690000	69FFFF
104	680000	68FFFF
103	670000	67FFFF
102	660000	66FFFF
101	650000	65FFFF
100	640000	64FFFF
99	630000	63FFFF
98	620000	62FFFF
97	610000	61FFFF
96	600000	60FFFF
95	5F0000	5FFFFF
94	5E0000	5EFFFF
93	5D0000	5DFFFF
92	5C0000	5CFFFF
91	5B0000	5BFFFF
90	5A0000	5AFFFF
89	590000	59FFFF
88	580000	58FFFF
87	570000	57FFFF
86	560000	56FFFF
85	550000	55FFFF
84	540000	54FFFF
83	530000	53FFFF
82	520000	52FFFF

Table 12. Memory organization (uniform) (page 6 of 8)

Sector	Address range	
	81	510000
80	500000	50FFFF
79	4F0000	4FFFFF
78	4E0000	4EFFFF
77	4D0000	4DFFFF
76	4C0000	4CFFFF
75	4B0000	4BFFFF
74	4A0000	4AFFFF
73	490000	49FFFF
72	480000	48FFFF
71	470000	47FFFF
70	460000	46FFFF
69	450000	45FFFF
68	440000	44FFFF
67	430000	43FFFF
66	420000	42FFFF
65	410000	41FFFF
64	400000	40FFFF
63	3F0000	3FFFFF
62	3E0000	3EFFFF
61	3D0000	3DFFFF
60	3C0000	3CFFFF
59	3B0000	3BFFFF
58	3A0000	3AFFFF
57	390000	39FFFF
56	380000	38FFFF
55	370000	37FFFF
54	360000	36FFFF
53	350000	35FFFF
52	340000	34FFFF
51	330000	33FFFF
50	320000	32FFFF
49	310000	31FFFF
48	300000	30FFFF
47	2F0000	2FFFFF

Table 12. Memory organization (uniform) (page 7 of 8)

Sector	Address range	
	46	2E0000
45	2D0000	2DFFFF
44	2C0000	2CFFFF
43	2B0000	2BFFFF
42	2A0000	2AFFFF
41	290000	29FFFF
40	280000	28FFFF
39	270000	27FFFF
38	260000	26FFFF
37	250000	25FFFF
36	240000	24FFFF
35	230000	23FFFF
34	220000	22FFFF
33	210000	21FFFF
32	200000	20FFFF
31	1F0000	1FFFFF
30	1E0000	1EFFFF
29	1D0000	1DFFFF
28	1C0000	1CFFFF
27	1B0000	1BFFFF
26	1A0000	1AFFFF
25	190000	19FFFF
24	180000	18FFFF
23	170000	17FFFF
22	160000	16FFFF
21	150000	15FFFF
20	140000	14FFFF
19	130000	13FFFF
18	120000	12FFFF
17	110000	11FFFF
16	100000	10FFFF
15	F0000	FFFFF
14	E0000	EFFFF
13	D0000	DFFFF
12	C0000	CFFFF

Table 12. Memory organization (uniform) (page 8 of 8)

Sector	Address range	
	11	B0000
10	A0000	AFFFF
9	90000	9FFFF
8	80000	8FFFF
7	70000	7FFFF
6	60000	6FFFF
5	50000	5FFFF
4	40000	4FFFF
3	30000	3FFFF
2	20000	2FFFF
1	10000	1FFFF
0	0	FFFF

Table 13. Memory organization (bottom) (page 1 of 9)

Sector	Subsector	Address range	
		255	-
254	-	FE0000	FEFFFF
253	-	FD0000	FDFFFF
252	-	FC0000	FCFFFF
251	-	FB0000	FBFFFF
250	-	FA0000	FAFFFF
249	-	F90000	F9FFFF
248	-	F80000	F8FFFF
247	-	F70000	F7FFFF
246	-	F60000	F6FFFF
245	-	F50000	F5FFFF
244	-	F40000	F4FFFF
243	-	F30000	F3FFFF
242	-	F20000	F2FFFF
241	-	F10000	F1FFFF
240	-	F00000	F0FFFF
239	-	EF0000	EFFFFF
238	-	EE0000	EEFFFF
237	-	ED0000	EDFFFF
236	-	EC0000	ECFFFF

Table 13. Memory organization (bottom) (page 2 of 9)

Sector	Subsector	Address range	
235	-	EB0000	EBFFFF
234	-	EA0000	EAF000
233	-	E90000	E9FFFF
232	-	E80000	E8FFFF
231	-	E70000	E7FFFF
230	-	E60000	E6FFFF
229	-	E50000	E5FFFF
228	-	E40000	E4FFFF
227	-	E30000	E3FFFF
226	-	E20000	E2FFFF
225	-	E10000	E1FFFF
224	-	E00000	E0FFFF
223	-	DF0000	DFFFFF
222	-	DE0000	DEFFFF
221	-	DD0000	DDFFFF
220	-	DC0000	DCFFFF
219	-	DB0000	DBFFFF
218	-	DA0000	DAFFFF
217	-	D90000	D9FFFF
216	-	D80000	D8FFFF
215	-	D70000	D7FFFF
214	-	D60000	D6FFFF
213	-	D50000	D5FFFF
212	-	D40000	D4FFFF
211	-	D30000	D3FFFF
210	-	D20000	D2FFFF
209	-	D10000	D1FFFF
208	-	D00000	D0FFFF
207	-	CF0000	CFFFFF
206	-	CE0000	CEFFFF
205	-	CD0000	CDFFFF
204	-	CC0000	CCFFFF
203	-	CB0000	CBFFFF
202	-	CA0000	CAFFFF
201	-	C90000	C9FFFF

Table 13. Memory organization (bottom) (page 3 of 9)

Sector	Subsector	Address range	
200	-	C80000	C8FFFF
199	-	C70000	C7FFFF
198	-	C60000	C6FFFF
197	-	C50000	C5FFFF
196	-	C40000	C4FFFF
195	-	C30000	C3FFFF
194	-	C20000	C2FFFF
193	-	C10000	C1FFFF
192	-	C00000	C0FFFF
191	-	BF0000	BFFFFF
190	-	BE0000	BEFFFF
189	-	BD0000	BDFFFF
188	-	BC0000	BCFFFF
187	-	BB0000	BBFFFF
186	-	BA0000	BAFFFF
185	-	B90000	B9FFFF
184	-	B80000	B8FFFF
183	-	B70000	B7FFFF
182	-	B60000	B6FFFF
181	-	B50000	B5FFFF
180	-	B40000	B4FFFF
179	-	B30000	B3FFFF
178	-	B20000	B2FFFF
177	-	B10000	B1FFFF
176	-	B00000	B0FFFF
175	-	AF0000	AFFFFF
174	-	AE0000	AEFFFF
173	-	AD0000	ADFFFF
172	-	AC0000	ACFFFF
171	-	AB0000	ABFFFF
170	-	AA0000	AAFFFF
169	-	A90000	A9FFFF
168	-	A80000	A8FFFF
167	-	A70000	A7FFFF
166	-	A60000	A6FFFF

Table 13. Memory organization (bottom) (page 4 of 9)

Sector	Subsector	Address range	
165	-	A50000	A5FFFF
164	-	A40000	A4FFFF
163	-	A30000	A3FFFF
162	-	A20000	A2FFFF
161	-	A10000	A1FFFF
160	-	A00000	A0FFFF
159	-	9F0000	9FFFFF
158	-	9E0000	9EFFFF
157	-	9D0000	9DFFFF
156	-	9C0000	9CFFFF
155	-	9B0000	9BFFFF
154	-	9A0000	9AFFFF
153	-	990000	99FFFF
152	-	980000	98FFFF
151	-	970000	97FFFF
150	-	960000	96FFFF
149	-	950000	95FFFF
148	-	940000	94FFFF
147	-	930000	93FFFF
146	-	920000	92FFFF
145	-	910000	91FFFF
144	-	900000	90FFFF
143	-	8F0000	8FFFFF
142	-	8E0000	8EFFFF
141	-	8D0000	8DFFFF
140	-	8C0000	8CFFFF
139	-	8B0000	8BFFFF
138	-	8A0000	8AFFFF
137	-	890000	89FFFF
136	-	880000	88FFFF
135	-	870000	87FFFF
134	-	860000	86FFFF
133	-	850000	85FFFF
132	-	840000	84FFFF
131	-	830000	83FFFF

Table 13. Memory organization (bottom) (page 5 of 9)

Sector	Subsector	Address range	
130	-	820000	82FFFF
129	-	810000	81FFFF
128	-	800000	80FFFF
127	-	7F0000	7FFFFF
126	-	7E0000	7EFFFF
125	-	7D0000	7DFFFF
124	-	7C0000	7CFFFF
123	-	7B0000	7BFFFF
122	-	7A0000	7AFFFF
121	-	790000	79FFFF
120	-	780000	78FFFF
119	-	770000	77FFFF
118	-	760000	76FFFF
117	-	750000	75FFFF
116	-	740000	74FFFF
115	-	730000	73FFFF
114	-	720000	72FFFF
113	-	710000	71FFFF
112	-	700000	70FFFF
111	-	6F0000	6FFFFF
110	-	6E0000	6EFFFF
109	-	6D0000	6DFFFF
108	-	6C0000	6CFFFF
107	-	6B0000	6BFFFF
106	-	6A0000	6AFFFF
105	-	690000	69FFFF
104	-	680000	68FFFF
103	-	670000	67FFFF
102	-	660000	66FFFF
101	-	650000	65FFFF
100	-	640000	64FFFF
99	-	630000	63FFFF
98	-	620000	62FFFF
97	-	610000	61FFFF
96	-	600000	60FFFF

Table 13. Memory organization (bottom) (page 6 of 9)

Sector	Subsector	Address range	
95	-	5F0000	5FFFFFF
94	-	5E0000	5EFFFF
93	-	5D0000	5DFFFF
92	-	5C0000	5CFFFF
91	-	5B0000	5BFFFF
90	-	5A0000	5AFFFF
89	-	590000	59FFFF
88	-	580000	58FFFF
87	-	570000	57FFFF
86	-	560000	56FFFF
85	-	550000	55FFFF
84	-	540000	54FFFF
83	-	530000	53FFFF
82	-	520000	52FFFF
81	-	510000	51FFFF
80	-	500000	50FFFF
79	-	4F0000	4FFFFFF
78	-	4E0000	4EFFFF
77	-	4D0000	4DFFFF
76	-	4C0000	4CFFFF
75	-	4B0000	4BFFFF
74	-	4A0000	4AFFFF
73	-	490000	49FFFF
72	-	480000	48FFFF
71	-	470000	47FFFF
70	-	460000	46FFFF
69	-	450000	45FFFF
68	-	440000	44FFFF
67	-	430000	43FFFF
66	-	420000	42FFFF
65	-	410000	41FFFF
64	-	400000	40FFFF
63	-	3F0000	3FFFFFF
62	-	3E0000	3EFFFF
61	-	3D0000	3DFFFF

Table 13. Memory organization (bottom) (page 7 of 9)

Sector	Subsector	Address range	
60	-	3C0000	3CFFFF
59	-	3B0000	3BFFFF
58	-	3A0000	3AFFFF
57	-	390000	39FFFF
56	-	380000	38FFFF
55	-	370000	37FFFF
54	-	360000	36FFFF
53	-	350000	35FFFF
52	-	340000	34FFFF
51	-	330000	33FFFF
50	-	320000	32FFFF
49	-	310000	31FFFF
48	-	300000	30FFFF
47	-	2F0000	2FFFFF
46	-	2E0000	2EFFFF
45	-	2D0000	2DFFFF
44	-	2C0000	2CFFFF
43	-	2B0000	2BFFFF
42	-	2A0000	2AFFFF
41	-	290000	29FFFF
40	-	280000	28FFFF
39	-	270000	27FFFF
38	-	260000	26FFFF
37	-	250000	25FFFF
36	-	240000	24FFFF
35	-	230000	23FFFF
34	-	220000	22FFFF
33	-	210000	21FFFF
32	-	200000	20FFFF
31	-	1F0000	1FFFFF
30	-	1E0000	1EFFFF
29	-	1D0000	1DFFFF
28	-	1C0000	1CFFFF
27	-	1B0000	1BFFFF
26	-	1A0000	1AFFFF

Table 13. Memory organization (bottom) (page 8 of 9)

Sector	Subsector	Address range	
25	-	190000	19FFFF
24	-	180000	18FFFF
23	-	170000	17FFFF
22	-	160000	16FFFF
21	-	150000	15FFFF
20	-	140000	14FFFF
19	-	130000	13FFFF
18	-	120000	12FFFF
17	-	110000	11FFFF
16	-	100000	10FFFF
15	-	F0000	FFFFF
14	-	E0000	EFFFF
13	-	D0000	DFFFF
12	-	C0000	CFFFF
11	-	B0000	BFFFF
10	-	A0000	AFFFF
9	-	90000	9FFFF
8	-	80000	8FFFF
7	127	7F000	7FFFF
	⋮	⋮	⋮
6	112	70000	70FFF
	⋮	⋮	⋮
	96	60000	60FFF
5	95	5F000	5FFFF
	⋮	⋮	⋮
	80	50000	50FFF
4	79	4F000	4FFFF
	⋮	⋮	⋮
	64	40000	40FFF
3	63	3F000	3FFFF
	⋮	⋮	⋮
	48	30000	30FFF
2	47	2F000	2FFFF
	⋮	⋮	⋮
	32	20000	20FFF

Table 13. Memory organization (bottom) (page 9 of 9)

Sector	Subsector	Address range	
1	31	1F000	1FFFF
	⋮	⋮	⋮
	16	10000	10FFF
0	15	F000	FFFF
	⋮	⋮	⋮
	0	0	FFF

Table 14. Memory organization (top)

Sector	Subsector	Address range	
255	127	FFF000	FFFFFF
	⋮	⋮	⋮
	112	FF0000	FF0FFF
254	111	FEF000	FEFFFF
	⋮	⋮	⋮
	96	FE0000	FE0FFF
253	95	FDF000	FDFFFF
	⋮	⋮	⋮
	80	FD0000	FD0FFF
252	79	FCF000	FCFFFF
	⋮	⋮	⋮
	64	FC0000	FC0FFF
251	63	FBF000	FBFFFF
	⋮	⋮	⋮
	48	FB0000	FB0FFF
250	47	FAF000	FAFFFF
	⋮	⋮	⋮
	32	FA0000	FA0FFF
249	31	F9F000	F9FFFF
	⋮	⋮	⋮
	16	F90000	F90FFF
248	15	F8F000	F8FFFF
	⋮	⋮	⋮
	0	F80000	F80FFF
247	-	F70000	F7FFFF
246	-	F60000	F6FFFF
245	-	F50000	F5FFFF

Table 14. Memory organization (top)

Sector	Subsector	Address range	
244	-	F40000	F4FFFF
243	-	F30000	F3FFFF
242	-	F20000	F2FFFF
241	-	F10000	F1FFFF
240	-	F00000	F0FFFF
239	-	EF0000	EFFFFF
238	-	EE0000	EEFFFF
237	-	ED0000	EDFFFF
236	-	EC0000	ECFFFF
235	-	EB0000	EBFFFF
234	-	EA0000	EAfffff
233	-	E90000	E9FFFF
232	-	E80000	E8FFFF
231	-	E70000	E7FFFF
230	-	E60000	E6FFFF
229	-	E50000	E5FFFF
228	-	E40000	E4FFFF
227	-	E30000	E3FFFF
226	-	E20000	E2FFFF
225	-	E10000	E1FFFF
224	-	E00000	E0FFFF
223	-	DF0000	DFFFFF
222	-	DE0000	DEFFFF
221	-	DD0000	DDFFFF
220	-	DC0000	DCFFFF
219	-	DB0000	DBFFFF
218	-	DA0000	DAFFFF
217	-	D90000	D9FFFF
216	-	D80000	D8FFFF
215	-	D70000	D7FFFF
214	-	D60000	D6FFFF
213	-	D50000	D5FFFF
212	-	D40000	D4FFFF
211	-	D30000	D3FFFF
210	-	D20000	D2FFFF

Table 14. Memory organization (top)

Sector	Subsector	Address range	
209	-	D10000	D1FFFF
208	-	D00000	D0FFFF
207	-	CF0000	CEFFFF
206	-	CE0000	CEFFFF
205	-	CD0000	CDFFFF
204	-	CC0000	CCFFFF
203	-	CB0000	CBFFFF
202	-	CA0000	CAFFFF
201	-	C90000	C9FFFF
200	-	C80000	C8FFFF
199	-	C70000	C7FFFF
198	-	C60000	C6FFFF
197	-	C50000	C5FFFF
196	-	C40000	C4FFFF
195	-	C30000	C3FFFF
194	-	C20000	C2FFFF
193	-	C10000	C1FFFF
192	-	C00000	C0FFFF
191	-	BF0000	BEFFFF
190	-	BE0000	BEFFFF
189	-	BD0000	BDFFFF
188	-	BC0000	BCFFFF
187	-	BB0000	BBFFFF
186	-	BA0000	BAFFFF
185	-	B90000	B9FFFF
184	-	B80000	B8FFFF
183	-	B70000	B7FFFF
182	-	B60000	B6FFFF
181	-	B50000	B5FFFF
180	-	B40000	B4FFFF
179	-	B30000	B3FFFF
178	-	B20000	B2FFFF
177	-	B10000	B1FFFF
176	-	B00000	B0FFFF
175	-	AF0000	AFFFFF

Table 14. Memory organization (top)

Sector	Subsector	Address range	
174	-	AE0000	AEFFFF
173	-	AD0000	ADFFFF
172	-	AC0000	ACFFFF
171	-	AB0000	ABFFFF
170	-	AA0000	AAFFFF
169	-	A90000	A9FFFF
168	-	A80000	A8FFFF
167	-	A70000	A7FFFF
166	-	A60000	A6FFFF
165	-	A50000	A5FFFF
164	-	A40000	A4FFFF
163	-	A30000	A3FFFF
162	-	A20000	A2FFFF
161	-	A10000	A1FFFF
160	-	A00000	A0FFFF
159	-	9F0000	9FFFFF
158	-	9E0000	9EFFFF
157	-	9D0000	9DFFFF
156	-	9C0000	9CFFFF
155	-	9B0000	9BFFFF
154	-	9A0000	9AFFFF
153	-	990000	99FFFF
152	-	980000	98FFFF
151	-	970000	97FFFF
150	-	960000	96FFFF
149	-	950000	95FFFF
148	-	940000	94FFFF
147	-	930000	93FFFF
146	-	920000	92FFFF
145	-	910000	91FFFF
144	-	900000	90FFFF
143	-	8F0000	8FFFFF
142	-	8E0000	8EFFFF
141	-	8D0000	8DFFFF
140	-	8C0000	8CFFFF

Table 14. Memory organization (top)

Sector	Subsector	Address range	
139	-	8B0000	8BFFFF
138	-	8A0000	8AFFFF
137	-	890000	89FFFF
136	-	880000	88FFFF
135	-	870000	87FFFF
134	-	860000	86FFFF
133	-	850000	85FFFF
132	-	840000	84FFFF
131	-	830000	83FFFF
130	-	820000	82FFFF
129	-	810000	81FFFF
128	-	800000	80FFFF
127	-	7F0000	7FFFFF
126	-	7E0000	7EFFFF
125	-	7D0000	7DFFFF
124	-	7C0000	7CFFFF
123	-	7B0000	7BFFFF
122	-	7A0000	7AFFFF
121	-	790000	79FFFF
120	-	780000	78FFFF
119	-	770000	77FFFF
118	-	760000	76FFFF
117	-	750000	75FFFF
116	-	740000	74FFFF
115	-	730000	73FFFF
114	-	720000	72FFFF
113	-	710000	71FFFF
112	-	700000	70FFFF
111	-	6F0000	6FFFFF
110	-	6E0000	6EFFFF
109	-	6D0000	6DFFFF
108	-	6C0000	6CFFFF
107	-	6B0000	6BFFFF
106	-	6A0000	6AFFFF
105	-	690000	69FFFF

Table 14. Memory organization (top)

Sector	Subsector	Address range	
104	-	680000	68FFFF
103	-	670000	67FFFF
102	-	660000	66FFFF
101	-	650000	65FFFF
100	-	640000	64FFFF
99	-	630000	63FFFF
98	-	620000	62FFFF
97	-	610000	61FFFF
96	-	600000	60FFFF
95	-	5F0000	5FFFFF
94	-	5E0000	5EFFFF
93	-	5D0000	5DFFFF
92	-	5C0000	5CFFFF
91	-	5B0000	5BFFFF
90	-	5A0000	5AFFFF
89	-	590000	59FFFF
88	-	580000	58FFFF
87	-	570000	57FFFF
86	-	560000	56FFFF
85	-	550000	55FFFF
84	-	540000	54FFFF
83	-	530000	53FFFF
82	-	520000	52FFFF
81	-	510000	51FFFF
80	-	500000	50FFFF
79	-	4F0000	4FFFFF
78	-	4E0000	4EFFFF
77	-	4D0000	4DFFFF
76	-	4C0000	4CFFFF
75	-	4B0000	4BFFFF
74	-	4A0000	4AFFFF
73	-	490000	49FFFF
72	-	480000	48FFFF
71	-	470000	47FFFF
70	-	460000	46FFFF

Table 14. Memory organization (top)

Sector	Subsector	Address range	
69	-	450000	45FFFF
68	-	440000	44FFFF
67	-	430000	43FFFF
66	-	420000	42FFFF
65	-	410000	41FFFF
64	-	400000	40FFFF
63	-	3F0000	3FFFFF
62	-	3E0000	3EFFFF
61	-	3D0000	3DFFFF
60	-	3C0000	3CFFFF
59	-	3B0000	3BFFFF
58	-	3A0000	3AFFFF
57	-	390000	39FFFF
56	-	380000	38FFFF
55	-	370000	37FFFF
54	-	360000	36FFFF
53	-	350000	35FFFF
52	-	340000	34FFFF
51	-	330000	33FFFF
50	-	320000	32FFFF
49	-	310000	31FFFF
48	-	300000	30FFFF
47	-	2F0000	2FFFFF
46	-	2E0000	2EFFFF
45	-	2D0000	2DFFFF
44	-	2C0000	2CFFFF
43	-	2B0000	2BFFFF
42	-	2A0000	2AFFFF
41	-	290000	29FFFF
40	-	280000	28FFFF
39	-	270000	27FFFF
38	-	260000	26FFFF
37	-	250000	25FFFF
36	-	240000	24FFFF
35	-	230000	23FFFF

Table 14. Memory organization (top)

Sector	Subsector	Address range	
34	-	220000	22FFFF
33	-	210000	21FFFF
32	-	200000	20FFFF
31	-	1F0000	1FFFFF
30	-	1E0000	1EFFFF
29	-	1D0000	1DFFFF
28	-	1C0000	1CFFFF
27	-	1B0000	1BFFFF
26	-	1A0000	1AFFFF
25	-	190000	19FFFF
24	-	180000	18FFFF
23	-	170000	17FFFF
22	-	160000	16FFFF
21	-	150000	15FFFF
20	-	140000	14FFFF
19	-	130000	13FFFF
18	-	120000	12FFFF
17	-	110000	11FFFF
16	-	100000	10FFFF
15	-	F0000	FFFFF
14	-	E0000	EFFFF
13	-	D0000	DFFFF
12	-	C0000	CFFFF
11	-	B0000	BFFFF
10	-	A0000	AFFFF
9	-	90000	9FFFF
8	-	80000	8FFFF
7	-	70000	7FFFF
6	-	60000	6FFFF
5	-	50000	5FFFF
4	-	40000	4FFFF
3	-	30000	3FFFF
2	-	20000	2FFFF
1	-	10000	1FFFF
0	-	0	FFFF

9 Instructions

The device can work in three different protocols: Extended SPI, DIO-SPI and QIO-SPI. Each protocol has a dedicated instruction set, and each instruction set features the same functionality:

- Read, program and erase the memory and the 64 byte OTP area,
- Suspend and resume the program or erase operations,
- Read and modify all the registers and to read the device ID: please note that in this case there is a small functionality difference among the single and the multiple I/O read ID instructions. See [Section 9.2.1: Multiple I/O Read Identification protocol](#) and [Section 9.3.1: Multiple I/O Read Identification \(MIORDID\)](#).

The application can choose in every time of the device life which protocol to use by setting the dedicated bits either in the Non Volatile Configuration Register or the Volatile Enhanced Configuration Register.

Note: In multiple SPI protocols, all instructions, addresses, and data are parallel on two lines (DIO-SPI protocol) or four lines (QIO-SPI protocol).

All instructions, addresses and data are shifted in and out of the device, most significant bit first.

Serial Data input(s) is (are) sampled on the first rising edge of Serial Clock (C) after Chip Select (\bar{S}) is driven Low. Then, the one-byte instruction code must be shifted in to the device, most significant bit first, on Serial Data input(s), each bit being latched on the rising edges of Serial Clock (C). Instruction code is shifted into the device just on DQ0 in Extended SPI protocol, on DQ0 and DQ1 in DIO-SPI protocol and on DQ0, DQ1, DQ2, and DQ3 in QIO-SPI protocol.

In standard mode every instruction sequence starts with a one-byte instruction code. Depending on the instruction, this might be followed by address bytes, or by data bytes, or by both or none.

In XIP modes only read operation and exit XIP mode can be performed, and to read the memory content no instructions code are needed: the device directly receives addresses and after a configurable number of dummy clock cycle it outputs the required data.

9.1 Extended SPI Instructions

In Extended SPI protocol instruction set the instruction code is always shifted into the device just on DQ0 pin, while depending on the instruction addresses and input/output data can run on single, two or four wires.

In the case of a Read Instructions Data Bytes (READ), Read Data Bytes at Higher Speed (FAST_READ), Dual Output Fast Read (DOFR), Dual Input/Output Fast Read (DIOFR), Quad Output Fast Read (QOFR), Quad Input/Output Fast Read (QIOFR), Read OTP (ROTP), Read Lock Registers (RDLR), Read Status Register (RDSR), Read Flag Status Register (RFSR), Read NV Configuration Register (RDNVCR), Read Volatile Configuration Register (RDVCR), Read Volatile Enhanced Configuration Register (RDVECR) and Read Identification (RDID) instruction, the shifted-in instruction sequence is followed by a data-out sequence. Chip Select (\bar{S}) can be driven High after any bit of the data-out sequence is being shifted out.

In the case of a Page Program (PP), Program OTP (POTP), Dual Input Fast Program (DIFP), Dual Input Extended Fast Program (DIEFP), Quad Input Fast Program (QIFP), Quad Input Extended Fast Program (QIEFP), Subsector Erase (SSE), Sector Erase (SE), Bulk Erase (BE), Write Status Register (WRSR), Clear Flag Status Register (CLFSR), Write to Lock Register (WRLR), Write Configuration Register (WRVCR), Write Enhanced Configuration Register (WRVECR), Write NV Configuration Register (WRNVCR), Write Enable (WREN) or Write Disable (WRDI) instruction, Chip Select (\bar{S}) must be driven High exactly at a byte boundary, otherwise the instruction is rejected, and is not executed. That is, Chip Select (\bar{S}) must be driven High when the number of clock pulses after Chip Select (\bar{S}) being driven Low is an exact multiple of eight.

All attempts to access the memory array are ignored during:

- Write Status Register cycle
- Write Non Volatile Configuration Register
- Program cycle
- Erase cycle

The following continue unaffected, with one exception:

- Internal Write Status Register cycle,
- Write Non Volatile Configuration Register,
- Program cycle,
- Erase cycle

The only exception is the Program/Erase Suspend instruction (PES), that can be used to pause all the program and the erase cycles except for:

- Program OTP (POTP),
- Bulk Erase,
- Write Non Volatile Configuration Register.

The suspended program or erase cycle can be resumed by the Program/Erase Resume instruction (PER). During the program/erase cycles, the polling instructions (both on the Status register and on the Flag Status register) are also accepted to allow the application to check the end of the internal modify cycles.

Note: These polling instructions don't affect the internal cycles performing.

Table 15. Instruction set: extended SPI protocol (page 1 of 2)

Instruction	Description	One-byte Instruction Code (BIN)	One-byte Instruction Code (HEX)	Address bytes	Dummy clock cycle	Data bytes
RDID	Read Identification	1001 111x	9Eh / 9Fh	0	0	1 to 20
READ	Read Data Bytes	0000 0011	03h	3	0	1 to ∞
FAST_READ	Read Data Bytes at Higher Speed	0000 1011	0Bh	3	8 ⁽¹⁾	1 to ∞
DOFR	Dual Output Fast Read	0011 1011	3Bh	3	8 ⁽¹⁾	1 to ∞
DIOFR	Dual Input/Output Fast Read	1011 1011	BB	3	8 ⁽¹⁾	1 to ∞
QOFR	Quad Output Fast Read	0110 1011	6Bh	3	8 ⁽¹⁾	1 to ∞
QIOFR	Quad Input/Output Fast Read	1110 1011	EBh	3	10 ⁽¹⁾	1 to ∞
ROTP	Read OTP (Read of OTP area)	0100 1011	4Bh	3	8 ⁽¹⁾	1 to 65
WREN	Write Enable	0000 0110	06h	0	0	0
WRDI	Write Disable	0000 0100	04h	0	0	0
PP	Page Program	0000 0010	02h	3	0	1 to 256
DIFP	Dual Input Fast Program	1010 0010	A2h	3	0	1 to 256
DIEFP	Dual Input Extended Fast Program	1101 0010	D2h	3	0	1 to 256
QIFP	Quad Input Fast Program	0011 0010	32h	3	0	1 to 256
QIEFP	Quad Input Extended Fast Program	0001 0010	12h	3	0	1 to 256
POTP	Program OTP (Program of OTP area)	0100 0010	42h	3	0	1 to 65
SSE ⁽²⁾	SubSector Erase	0010 0000	20h	3	0	0
SE	Sector Erase	1101 1000	D8h	3	0	0
BE	Bulk Erase	1100 0111	C7h	0	0	0
PER	Program/Erase Resume	0111 1010	7Ah	0	0	0
PES	Program/Erase Suspend	0111 0101	75h	0	0	0
RDSR	Read Status Register	0000 0101	05h	0	0	1 to ∞
WRSR	Write Status Register	0000 0001	01h	0	0	1
RDLR	Read Lock Register	1110 1000	E8h	3	0	1 to ∞
WRLR	Write to Lock Register	1110 0101	E5h	3	0	1
RFSR	Read Flag Status Register	0111 0000	70h	0	0	1 to ∞
CLFSR	Clear Flag Status Register	0101 0000	50h	0	0	0
RDNVCR	Read NV Configuration Register	1011 0101	B5h	0	0	2
WRNVCR	Write NV Configuration Register	1011 0001	B1h	0	0	2
RDVCR	Read Volatile Configuration Register	1000 0101	85h	0	0	1 to ∞
WRVCR	Write Volatile Configuration Register	1000 0001	81h	0	0	1

Table 15. Instruction set: extended SPI protocol (page 2 of 2)

Instruction	Description	One-byte Instruction Code (BIN)	One-byte Instruction Code (HEX)	Address bytes	Dummy clock cycle	Data bytes
RDVECR	Read Volatile Enhanced Configuration Register	0110 0101	65h	0	0	1 to ∞
WRVECR	Write Volatile Enhanced Configuration Register	0110 0001	61h	0	0	1
DP	Deep Power-down	1011 1001	B9h	0	0	0
RDP	Release from Deep Power-down	1010 1011	ABh	0	0	0

- 1) The Number of dummy clock cycles is configurable by user
 2) Subsector erase instruction is only available in Bottom or Top parts

9.1.1 Read Identification (RDID)

The Read Identification (RDID) instruction allows to read the device identification data:

- Manufacturer identification (1 byte)
- Device identification (2 bytes)
- A Unique ID code (UID) (17 bytes, of which 14 factory programmed upon customer request).

The manufacturer identification is assigned by JEDEC, and has the value 20h. The device identification is assigned by the device manufacturer, and indicates the memory type in the first byte (BBh), and the memory capacity of the device in the second byte (18h). The UID is composed by 17 read only bytes, containing the length of the following data in the first byte (set to 10h), 2 bytes of Extended Device ID (EDID) to identify the specific device configuration (Top, Bottom or uniform architecture, Hold or Reset functionality), and 14 bytes of the optional Customized Factory Data (CFD) content. The CFD bytes can be factory programmed with customers data upon their demand. If the customers do not make requests, the devices are shipped with all the CFD bytes programmed to zero (00h).

Any Read Identification (RDID) instruction while an Erase or Program cycle is in progress, is not decoded, and has no effect on the cycle that is in progress.

The device is first selected by driving Chip Select (\overline{S}) Low. Then, the 8-bit instruction code for the instruction is shifted in. After this, the 24-bit device identification, stored in the memory, the 17 bytes of UID content will be shifted out on Serial Data output (DQ1). Each bit is shifted out during the falling edge of Serial Clock (C).

The instruction sequence is shown in Figure 10.

The Read Identification (RDID) instruction is terminated by driving Chip Select (\overline{S}) High at any time during data output.

When Chip Select (\overline{S}) is driven High, the device is put in the Standby Power mode. Once in the Standby Power mode, the device waits to be selected, so that it can receive, decode and execute instructions.

Table 16. Read Identification data-out sequence

Manufacturer Identification	Device identification		UID		
	Memory type	Memory capacity	EDID+CFD length	EDID	CFD
20h	BBh	18h	10h	2 bytes	14 bytes

Table 17. Extended Device ID table (first byte)

Bit 7	Bit 6	Bit 5	Bit 4	Bit 3	Bit 2	Bit 1	Bit 0
Reserved	Reserved	Reserved	VCR XIP bit setting: 0 = required, 1 = not required	Hold/Reset function: 0 = HOLD, 1 = Reset	Addressing: 0 = by Byte,	Architecture: 00 = Uniform, 01 = Bottom, 11 = Top	

Figure 10. Read identification instruction and data-out sequence

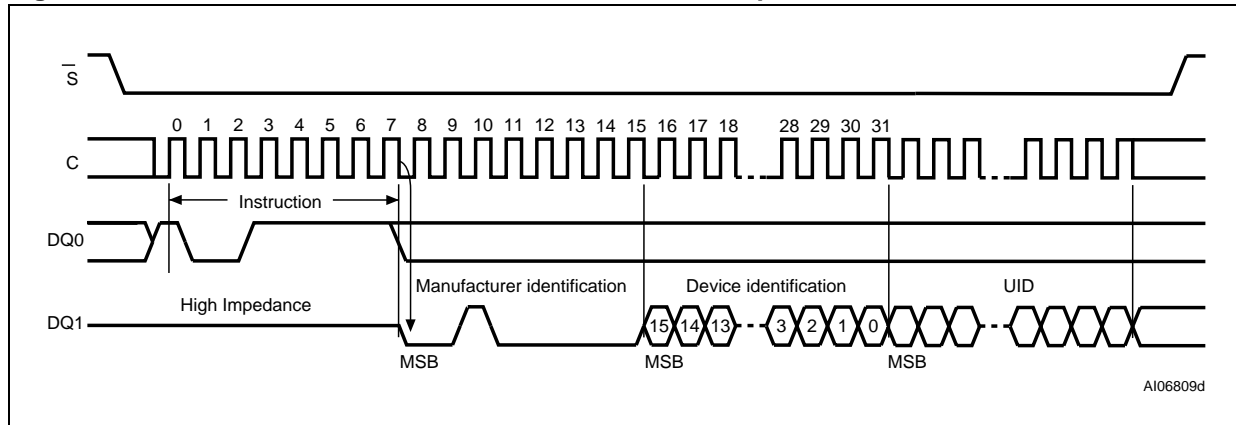

9.1.2 Read Data Bytes (READ)

The device is first selected by driving Chip Select (\bar{S}) Low. The instruction code for the Read Data Bytes (READ) instruction is followed by a 3-byte address (A23-A0), each bit being latched-in during the rising edge of Serial Clock (C). Then the memory contents, at that address, is shifted out on Serial Data output (DQ1), each bit being shifted out, at a maximum frequency f_R , during the falling edge of Serial Clock (C).

The first byte addressed can be at any location. The address is automatically incremented to the next higher address after each byte of data is shifted out. The whole memory can, therefore, be read with a single Read Data Bytes (READ) instruction. When the highest address is reached, the address counter rolls over to 000000h, allowing the read sequence to be continued indefinitely.

The Read Data Bytes (READ) instruction is terminated by driving Chip Select (\bar{S}) High. Chip Select (\bar{S}) can be driven High at any time during data output. Any Read Data Bytes (READ) instruction, while an Erase, Program or Write cycle is in progress, is rejected without having any effects on the cycle that is in progress.

Figure 11. Read Data Bytes instruction and data-out sequence

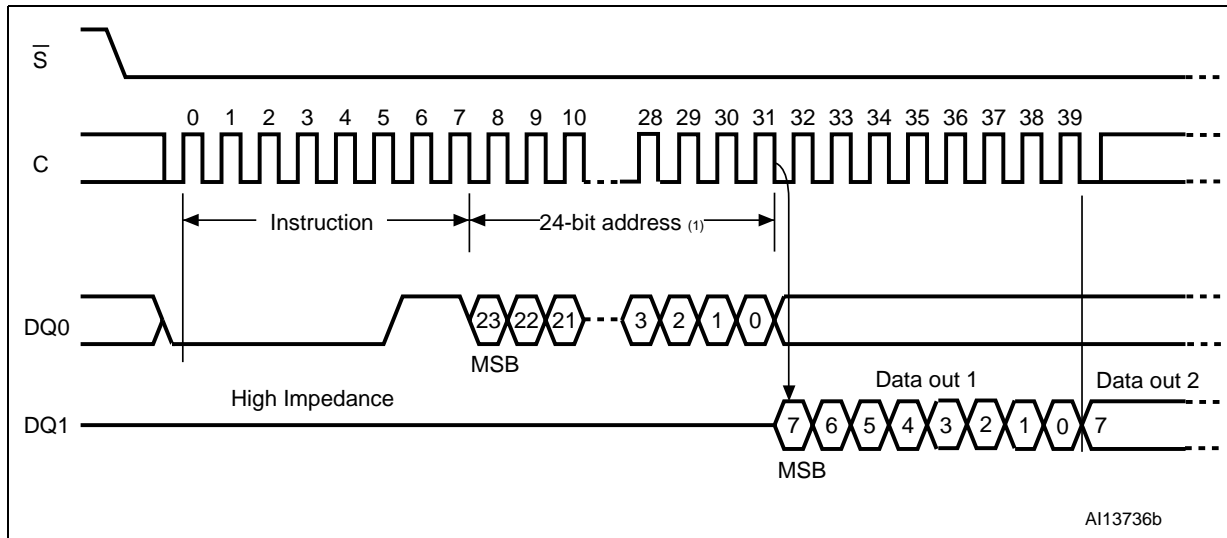

9.1.3 Read Data Bytes at Higher Speed (FAST_READ)

The device is first selected by driving Chip Select (\bar{S}) Low. The instruction code for the Read Data Bytes at Higher Speed (FAST_READ) instruction is followed by a 3-byte address (A23-A0) and a dummy byte, each bit being latched-in during the rising edge of Serial Clock (C).

Then the memory contents, at that address, are shifted out on Serial Data output (DQ1) at a maximum frequency f_C , during the falling edge of Serial Clock (C).

The first byte addressed can be at any location. The address is automatically incremented to the next higher address after each byte of data is shifted out. The whole memory can, therefore, be read with a single Read Data Bytes at Higher Speed (FAST_READ) instruction. When the highest address is reached, the address counter rolls over to 000000h, allowing the read sequence to be continued indefinitely.

The Read Data Bytes at Higher Speed (FAST_READ) instruction is terminated by driving Chip Select (\bar{S}) High. Chip Select (\bar{S}) can be driven High at any time during data output. Any Read Data Bytes at Higher Speed (FAST_READ) instruction, while an Erase, Program or Write cycle is in progress, is rejected without having any effects on the cycle that is in progress.

Figure 12. Read Data Bytes at Higher Speed instruction and data-out sequence

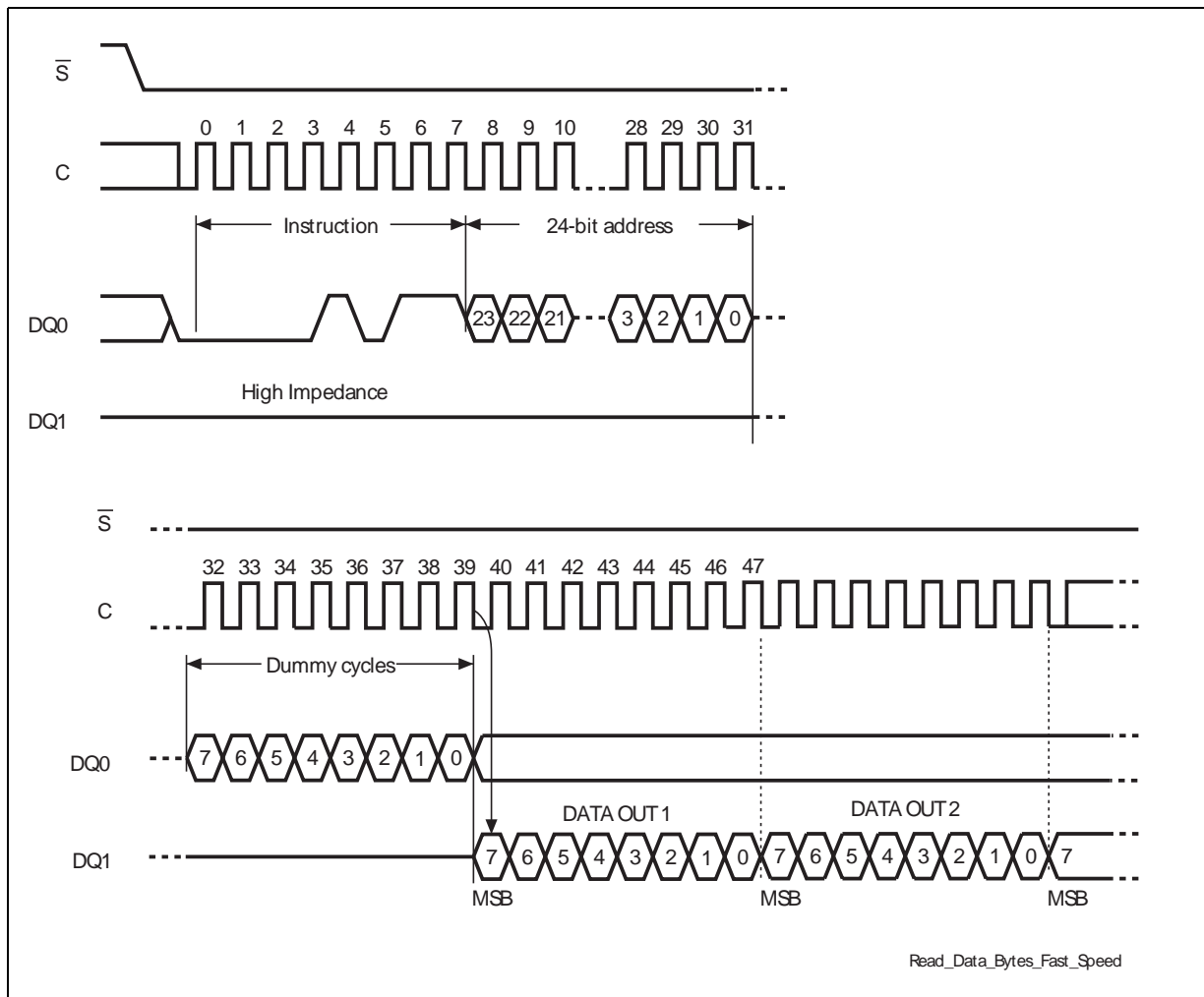

9.1.4 Dual Output Fast Read (DOFR)

The Dual Output Fast Read (DOFR) instruction is very similar to the Read Data Bytes at Higher Speed (FAST_READ) instruction, except that the data are shifted out on two pins (pin DQ0 and pin DQ1) instead of only one. Outputting the data on two pins instead of one doubles the data transfer bandwidth compared to the Read Data Bytes at Higher Speed (FAST_READ) instruction.

The device is first selected by driving Chip Select (\overline{S}) Low. The instruction code for the Dual Output Fast Read instruction is followed by a 3-byte address (A23-A0) and a dummy byte, each bit being latched-in during the rising edge of Serial Clock (C). Then the memory contents, at that address, are shifted out on DQ0 and DQ1 at a maximum frequency F_c , during the falling edge of Serial Clock (C).

The first byte addressed can be at any location. The address is automatically incremented to the next higher address after each byte of data is shifted out on DQ0 and DQ1. The whole memory can, therefore, be read with a single Dual Output Fast Read (DOFR) instruction.

When the highest address is reached, the address counter rolls over to 00 0000h, so that the read sequence can be continued indefinitely.

Figure 13. Dual Output Fast Read instruction sequence

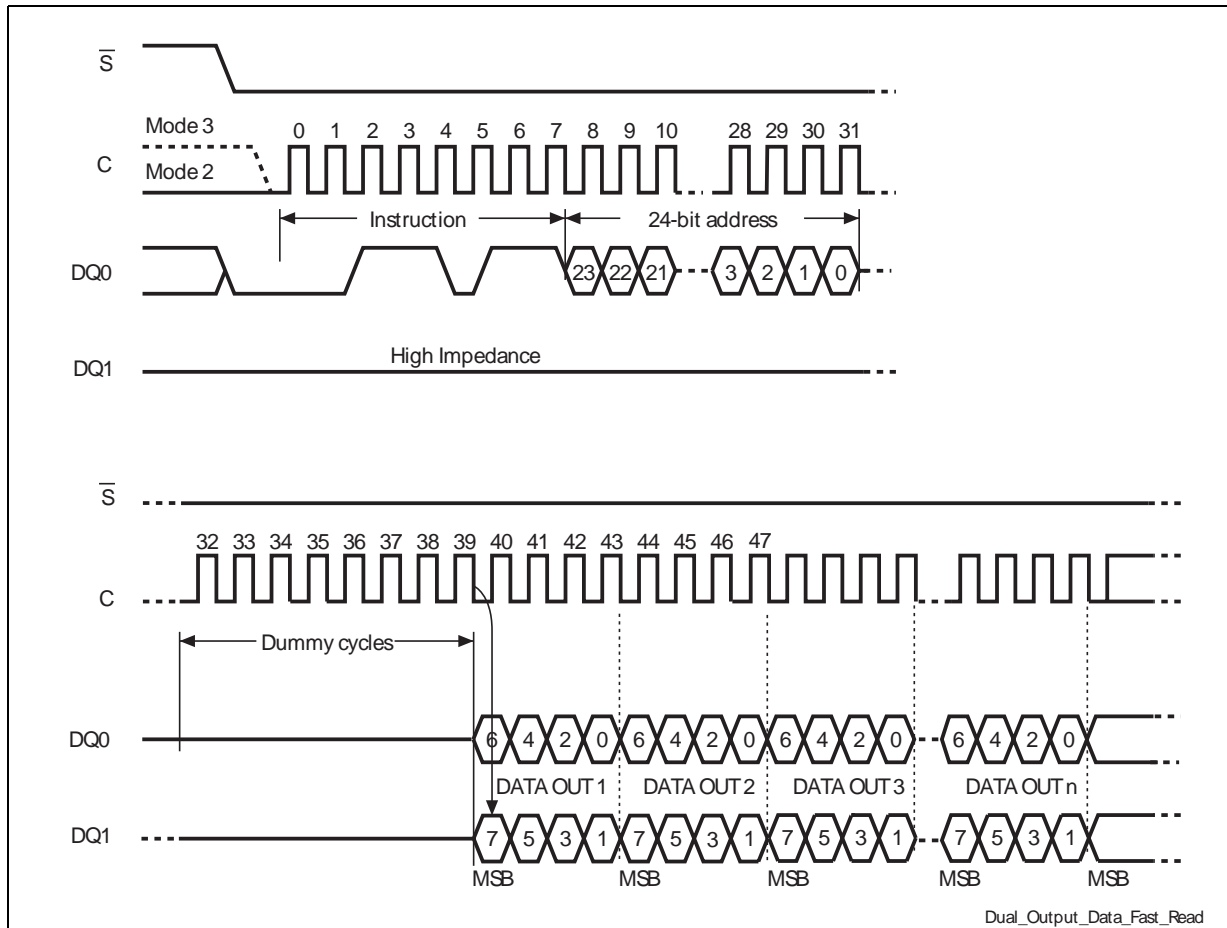

9.1.5 Dual I/O Fast Read

The Dual I/O Fast Read (DIOFR) instruction is very similar to the Dual Output Fast Read (DOFR), except that the address bits are shifted in on two pins (pin DQ0 and pin DQ1) instead of only one.

Figure 14. Dual I/O Fast Read instruction sequence

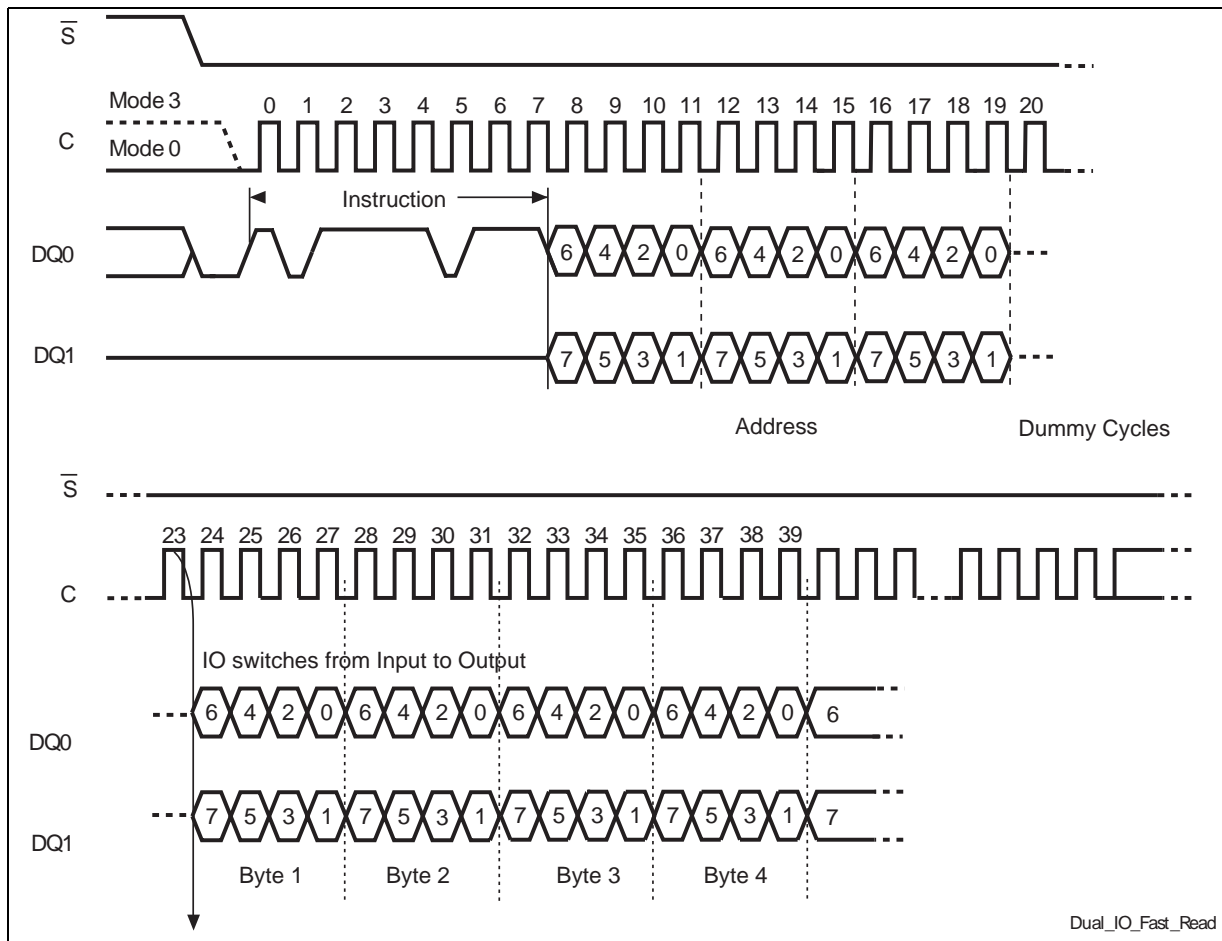

9.1.6 Quad Output Fast Read

The Quad Output Fast Read (QOFR) instruction is very similar to the Dual Output Fast Read (DOFR) instruction, except that the data are shifted out on four pins (pin DQ0, pin DQ1, pin W/VPP/DQ2 and pin HOLD/DQ3 (1) instead of only two. Outputting the data on four pins instead of one doubles the data transfer bandwidth compared to the Dual Output Fast Read (DOFR) instruction.

The device is first selected by driving Chip Select (\bar{S}) Low. The instruction code for the Quad Output Fast Read instruction is followed by a 3-byte address (A23-A0) and a dummy byte, each bit being latched-in during the rising edge of Serial Clock (C). Then the memory contents, at that address, are shifted out on pin DQ0, pin DQ1, pin W/VPP/DQ2 and pin HOLD/DQ3 (1) at a maximum frequency f_C , during the falling edge of Serial Clock (C).

The instruction sequence is shown in Figure 15.

The first byte addressed can be at any location. The address is automatically incremented to the next higher address after each byte of data is shifted out on pin DQ0, pin DQ1, pin W/VPP/DQ2 and pin HOLD/DQ3 (1). The whole memory can, therefore, be read with a single Quad Output Fast Read (QOFR) instruction.

When the highest address is reached, the address counter rolls over to 00 0000h, so that the read sequence can be continued indefinitely.

Note: Reset functionality is available instead of Hold in devices with a dedicated part number. See [Section 16: Ordering information](#).

Figure 15. Quad Input/Output Fast Read instruction sequence

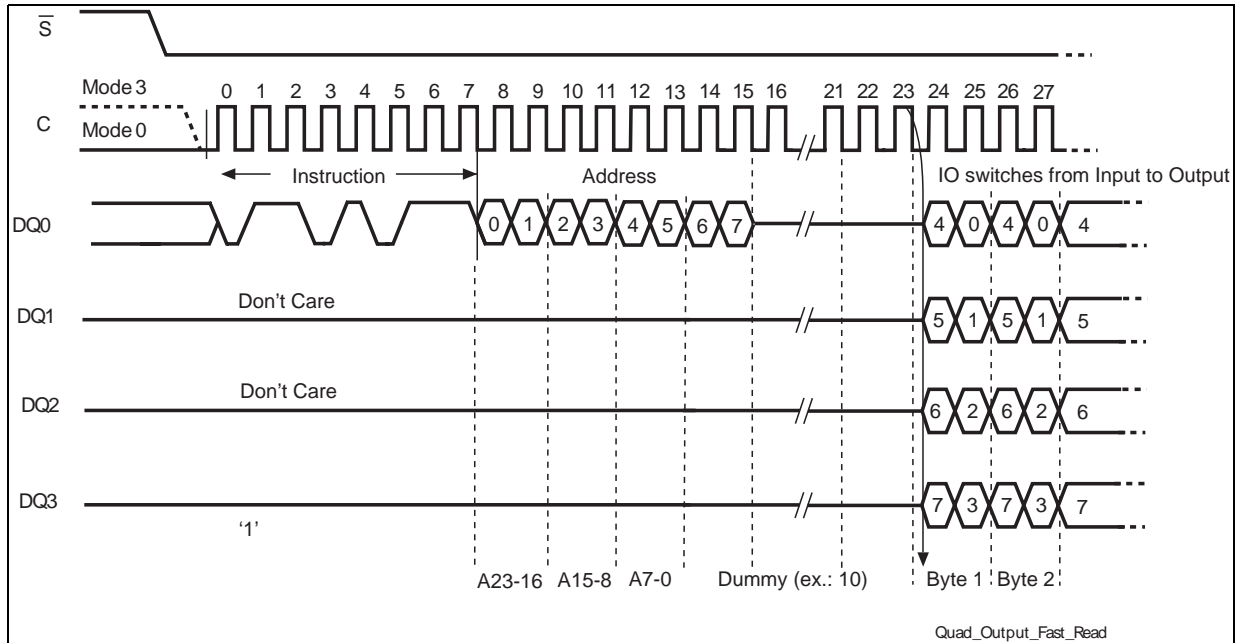

9.1.7 Quad I/O Fast Read

The Quad I/O Fast Read (QIOFR) instruction is very similar to the Quad Output Fast Read (QOFR), except that the address bits are shifted in on four pins (pin $DQ0$, pin $DQ1$, pin $W/VPP/DQ2$ and pin $HOLD/DQ3$ (1)) instead of only one.

Note: Reset functionality is available instead of Hold in devices with a dedicated part number. See [Section 16: Ordering information](#).

Figure 16. Quad Input/ Output Fast Read instruction sequence

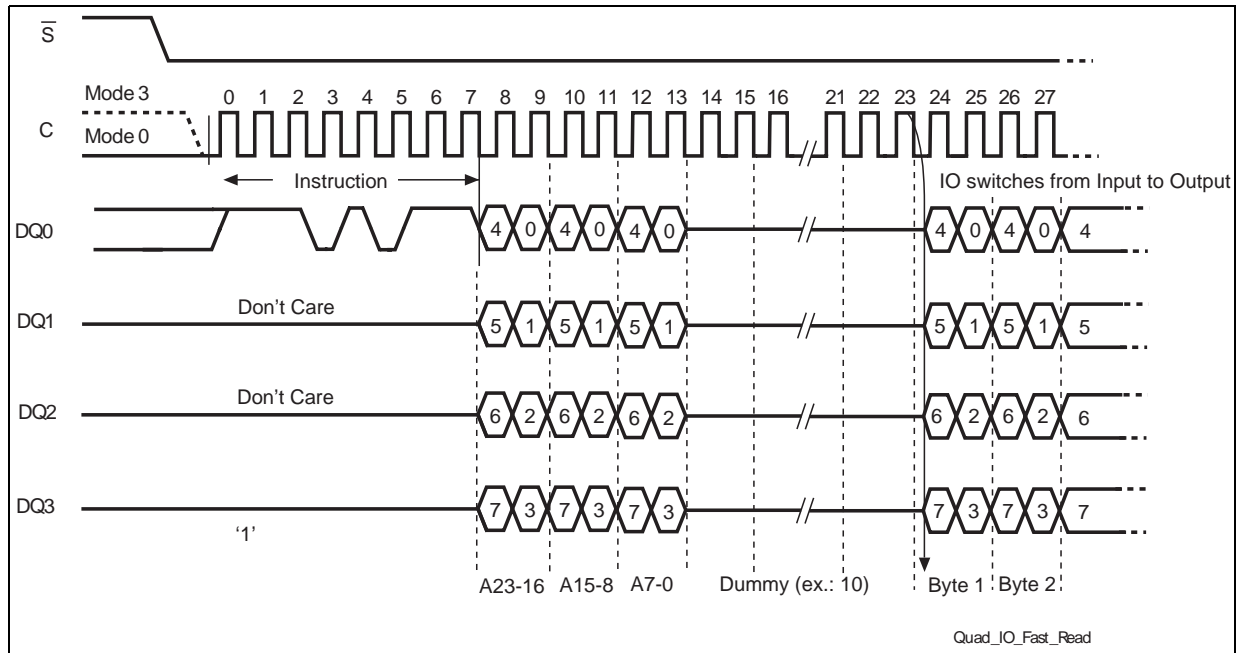

9.1.8 Read OTP (ROTP)

The device is first selected by driving Chip Select (\overline{S}) Low. The instruction code for the Read OTP (ROTP) instruction is followed by a 3-byte address (A23- A0) and a dummy byte. Each bit is latched in on the rising edge of Serial Clock (C).

Then the memory contents at that address are shifted out on Serial Data output (DQ1).

Each bit is shifted out at the maximum frequency, f_{Cmax} , on the falling edge of Serial Clock (C). The instruction sequence is shown in Figure 17.

The address is automatically incremented to the next higher address after each byte of data is shifted out.

There is no rollover mechanism with the Read OTP (ROTP) instruction. This means that the Read OTP (ROTP) instruction must be sent with a maximum of 65 bytes to read. All other bytes outside the OTP area are “Don’t Care.”

The Read OTP (ROTP) instruction is terminated by driving Chip Select (\overline{S}) High. Chip Select (\overline{S}) can be driven High at any time during data output. Any Read OTP (ROTP) instruction issued while an Erase, Program or Write cycle is in progress, is rejected without having any effect on the cycle that is in progress.

Figure 17. Read OTP instruction and data-out sequence

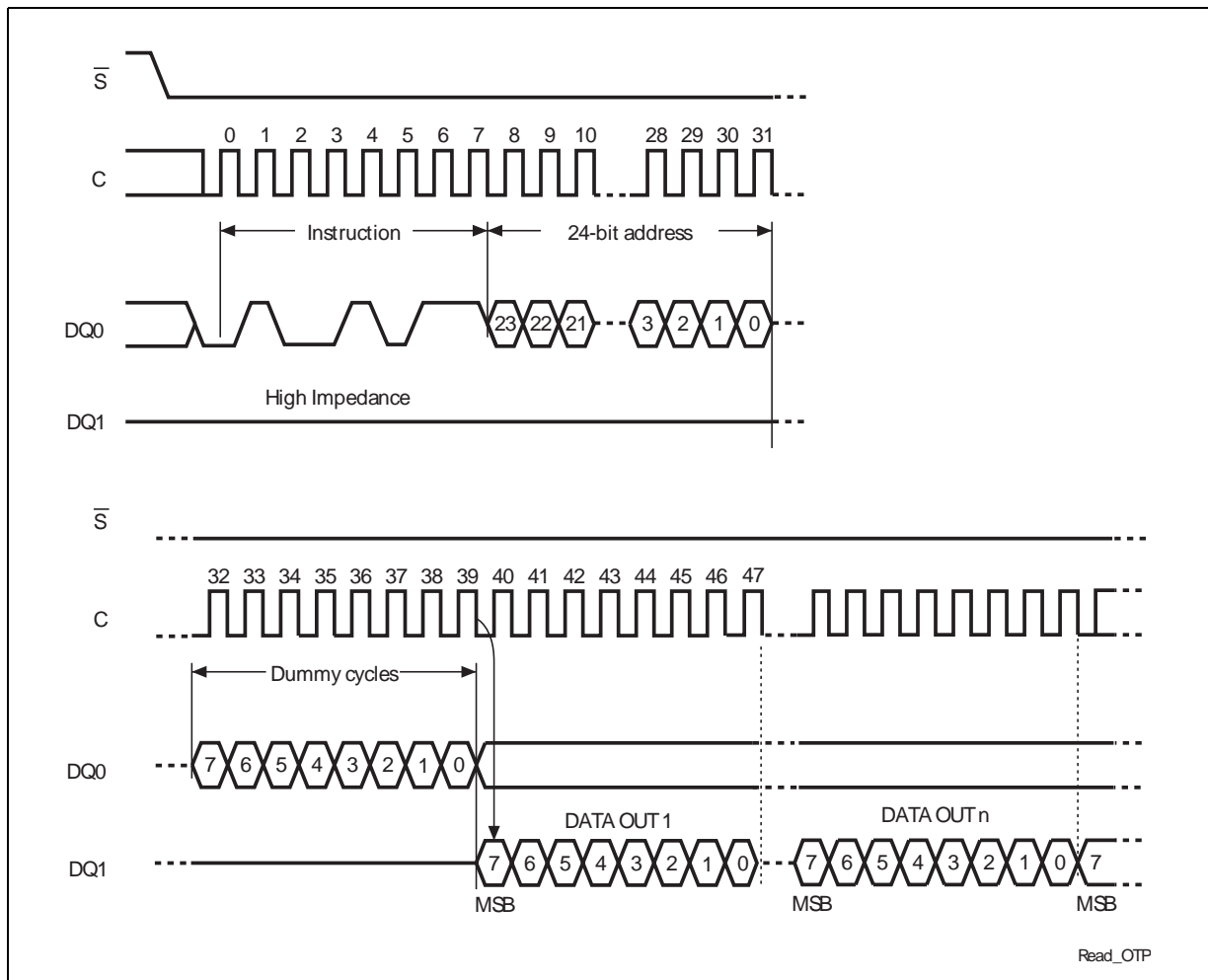

9.1.9 Write Enable (WREN)

The Write Enable (WREN) instruction (Figure 8) sets the Write Enable Latch (WEL) bit.

The Write Enable Latch (WEL) bit must be set prior to every Program, Erase or Write instructions:

Page Program (PP), Dual Input Fast Program (DIFP), Dual Input Extended Fast Program (DIEFP), Quad Input Fast Program (QIFP), Quad Input Extended Fast Program (QIEFP), Program OTP (POTP), Write to Lock Register (WRLR), Subsector Erase (SSE), Sector Erase (SE), Bulk Erase (BE), Write Status Register (WRSR), Write Configuration Register (WRCR), Write Enhanced Configuration Register (WRECR) and Write NV Configuration Register (WRNVCR) instruction.

The Write Enable (WREN) instruction is entered by driving Chip Select (\overline{S}) Low, sending the instruction code, and then driving Chip Select (\overline{S}) High.

When the Fast POR feature is selected (Non Volatile Configuration Register bit 5) after the first Write Enable instruction, the device enters in a latency time (~500 us), necessary to internally complete the POR sequence with the modify algorithms. (See [Section 11.1: Fast POR](#).) During the POR latency time all the instructions are ignored with the exception of the

polling instructions (to check if the internal cycle is finished by mean of the WIP bit of the Status Register or of the Program/Erase controller bit of the Flag Status register): to verify if the POR sequence is completed is possible to check the WIP bit in the Status Register or the Program/Erase Controller bit in the Flag Status Register, please note that the Program/Erase Controller bit in the Flag status register has the reverse logical polarity with respect to the Status Register WIP bit.

At the end of the POR sequence the WEL bit is low, so the next modify instruction can be accepted.

Figure 18. Write Enable instruction sequence

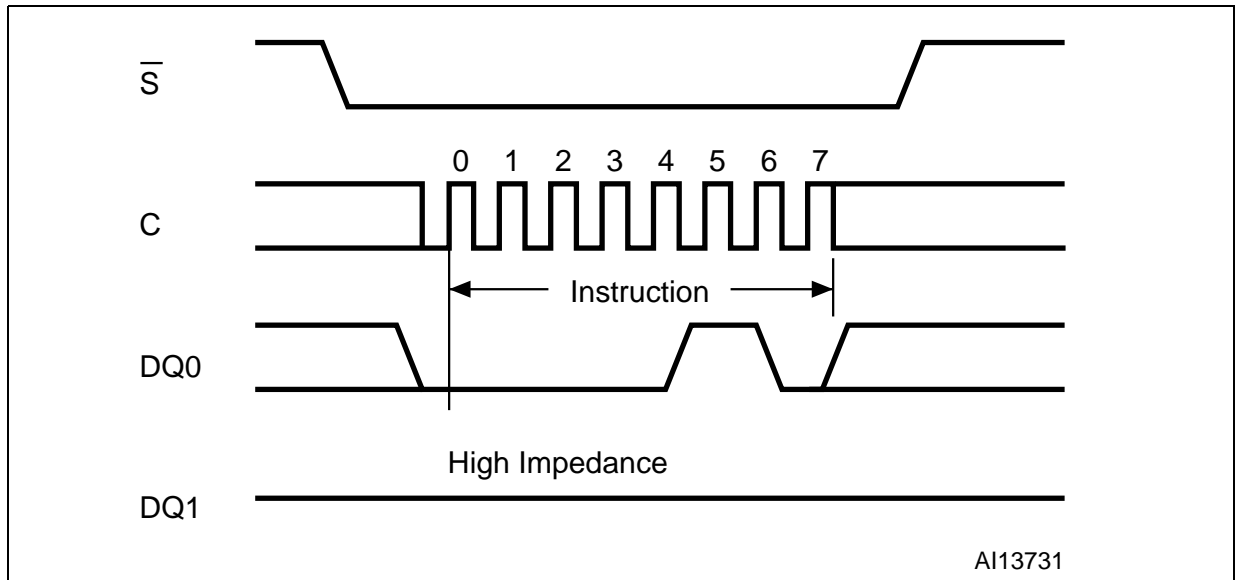

9.1.10 Write Disable (WRDI)

The Write Disable (WRDI) instruction (Figure 9) resets the Write Enable Latch (WEL) bit.

The Write Disable (WRDI) instruction is entered by driving Chip Select (\overline{S}) Low, sending the instruction code, and then driving Chip Select (\overline{S}) High.

The Write Enable Latch (WEL) bit is reset under the following conditions:

- Power-up
- Write Disable (WRDI) instruction completion
- Write Status Register (WRSR) instruction completion
- Write to Lock Register (WRLR) instruction completion
- Write Non Volatile Configuration Register (WRNVCR) instruction completion
- Write Volatile Configuration Register (WRVCR) instruction completion
- Write Volatile Enhanced Configuration Register (WRVECR) instruction completion
- Page Program (PP) instruction completion
- Dual Input Fast Program (DIFP) instruction completion
- Dual Input Extended Fast Program (DIEFP) instruction completion
- Quad Input Fast Program (QIFP) instruction completion
- Quad Input Extended Fast Program (QIEFP) instruction completion
- Program OTP (POTP) instruction completion
- Subsector Erase (SSE) instruction completion
- Sector Erase (SE) instruction completion
- Bulk Erase (BE) instruction completion

Figure 19. Write Disable instruction sequence

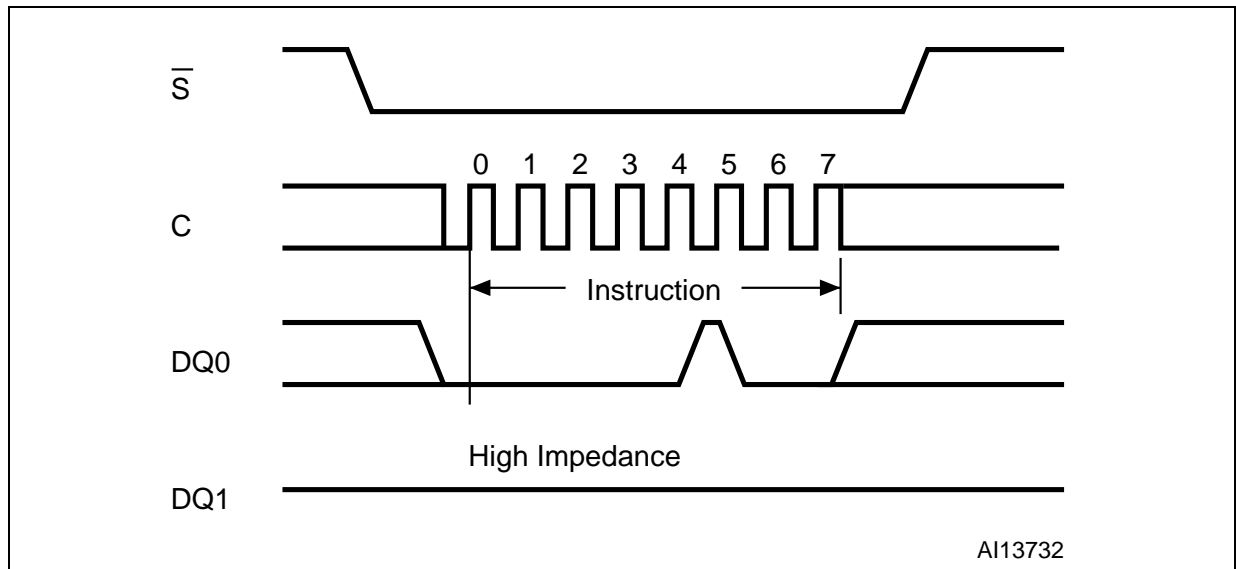

9.1.11 Page Program (PP)

The Page Program (PP) instruction allows bytes to be programmed in the memory (changing bits from 1 to 0). Before it can be accepted, a Write Enable (WREN) instruction must previously have been executed. After the Write Enable (WREN) instruction has been decoded, the device sets the Write Enable Latch (WEL).

The Page Program (PP) instruction is entered by driving Chip Select (\overline{S}) Low, followed by the instruction code, three address bytes and at least one data byte on Serial Data input (DQ0). If the 8 least significant address bits (A7-A0) are not all zero, all transmitted data that goes beyond the end of the current page are programmed from the start address of the

same page (from the address whose 8 least significant bits (A7-A0) are all zero). Chip Select (\bar{S}) must be driven Low for the entire duration of the sequence.

If more than 256 bytes are sent to the device, previously latched data are discarded and the last 256 data bytes are guaranteed to be programmed correctly within the same page. If less than 256 data bytes are sent to device, they are correctly programmed at the requested addresses without having any effects on the other bytes of the same page.

For optimized timings, it is recommended to use the Page Program (PP) instruction to program all consecutive targeted bytes in a single sequence versus using several Page Program (PP) sequences with each containing only a few bytes. See [Table 33.: AC Characteristics](#).

Chip Select (\bar{S}) must be driven High after the eighth bit of the last data byte has been latched in, otherwise the Page Program (PP) instruction is not executed.

As soon as Chip Select (\bar{S}) is driven High, the self-timed Page Program cycle (whose duration is t_{pp}) is initiated. While the Page Program cycle is in progress, the Status Register and the Flag Status Register may be read to check if the internal modify cycle is finished. At some unspecified time before the cycle is completed, the Write Enable Latch (WEL) bit is reset.

A Page Program (PP) instruction applied to a page which is protected by the Block Protect (BP3, BP2, BP1, BP0 and TB) bits is not executed.

Page Program cycle can be paused by mean of Program/Erase Suspend (PES) instruction and resumed by mean of Program/Erase Resume (PER) instruction.

Figure 20. Page Program instruction sequence

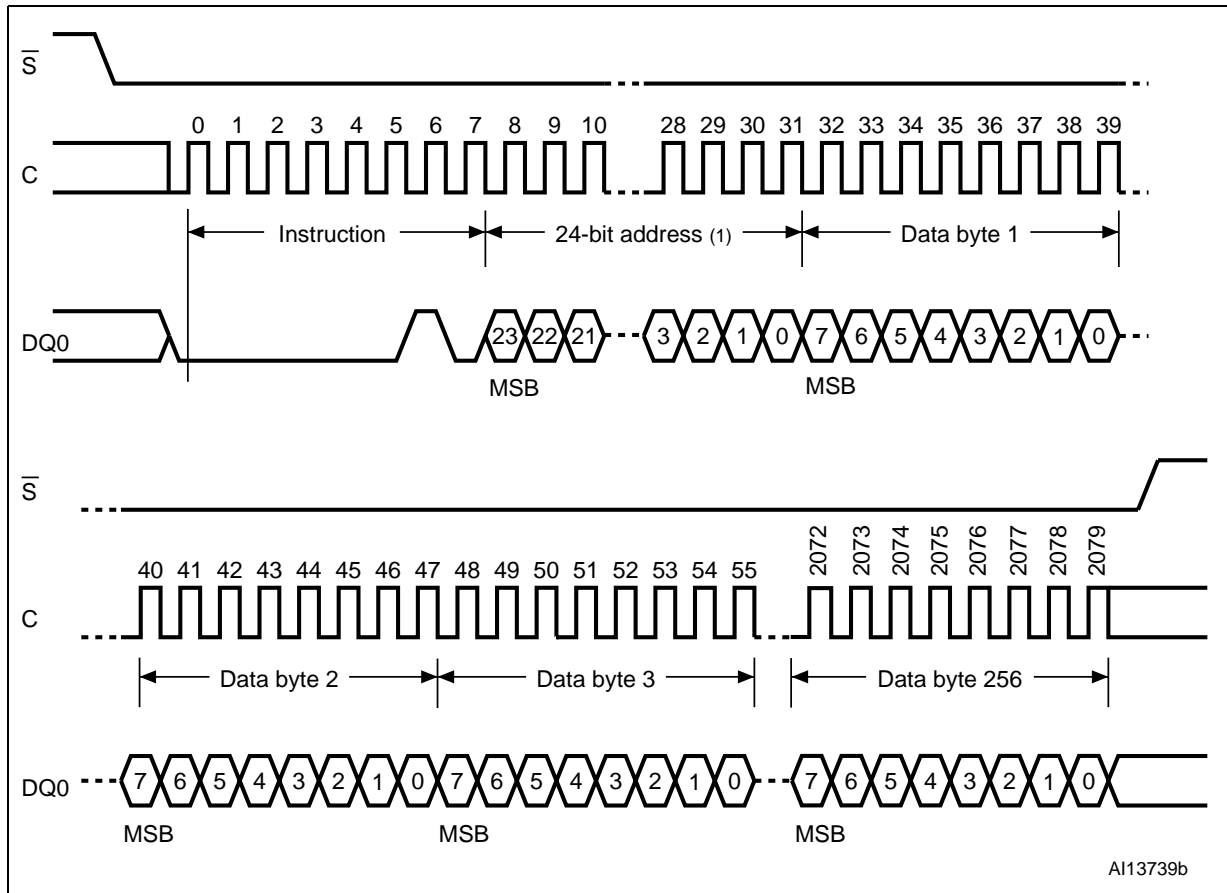

9.1.12 Dual Input Fast Program (DIFP)

The Dual Input Fast Program (DIFP) instruction is very similar to the Page Program (PP) instruction, except that the data are entered on two pins (pin DQ0 and pin DQ1) instead of only one. Inputting the data on two pins instead of one doubles the data transfer bandwidth compared to the Page Program (PP) instruction.

The Dual Input Fast Program (DIFP) instruction is entered by driving Chip Select (\bar{S}) Low, followed by the instruction code, three address bytes and at least one data byte on Serial Data input (DQ0).

If the 8 least significant address bits (A7-A0) are not all zero, all transmitted data that goes beyond the end of the current page are programmed from the start address of the same page (from the address whose 8 least significant bits (A7-A0) are all zero). Chip Select (\bar{S}) must be driven Low for the entire duration of the sequence.

If more than 256 bytes are sent to the device, previously latched data are discarded and the last 256 data bytes are guaranteed to be programmed correctly within the same page. If less than 256 data bytes are sent to device, they are correctly programmed at the requested addresses without having any effects on the other bytes in the same page.

For optimized timings, it is recommended to use the Dual Input Fast Program (DIFP) instruction to program all consecutive targeted bytes in a single sequence rather to using

several Dual Input Fast Program (DIFP) sequences each containing only a few bytes. See [Table 33.: AC Characteristics](#).

Chip Select (\bar{S}) must be driven High after the eighth bit of the last data byte has been latched in, otherwise the Dual Input Fast Program (DIFP) instruction is not executed.

As soon as Chip Select (\bar{S}) is driven High, the self-timed Page Program cycle (whose duration is t_{pp}) is initiated. While the Dual Input Fast Program (DIFP) cycle is in progress, the Status Register and the Flag Status Register may be read to check if the internal modify cycle is finished. At some unspecified time before the cycle is completed, the Write Enable Latch (WEL) bit is reset.

A Dual Input Fast Program (DIFP) instruction applied to a page that is protected by the Block Protect (BP3, BP2, BP1, BP0 and TB) bits is not executed.

Dual Input Fast Program cycle can be paused by mean of Program/Erase Suspend (PES) instruction and resumed by mean of Program/Erase Resume (PER) instruction.

Figure 21. Dual Input Fast Program instruction sequence

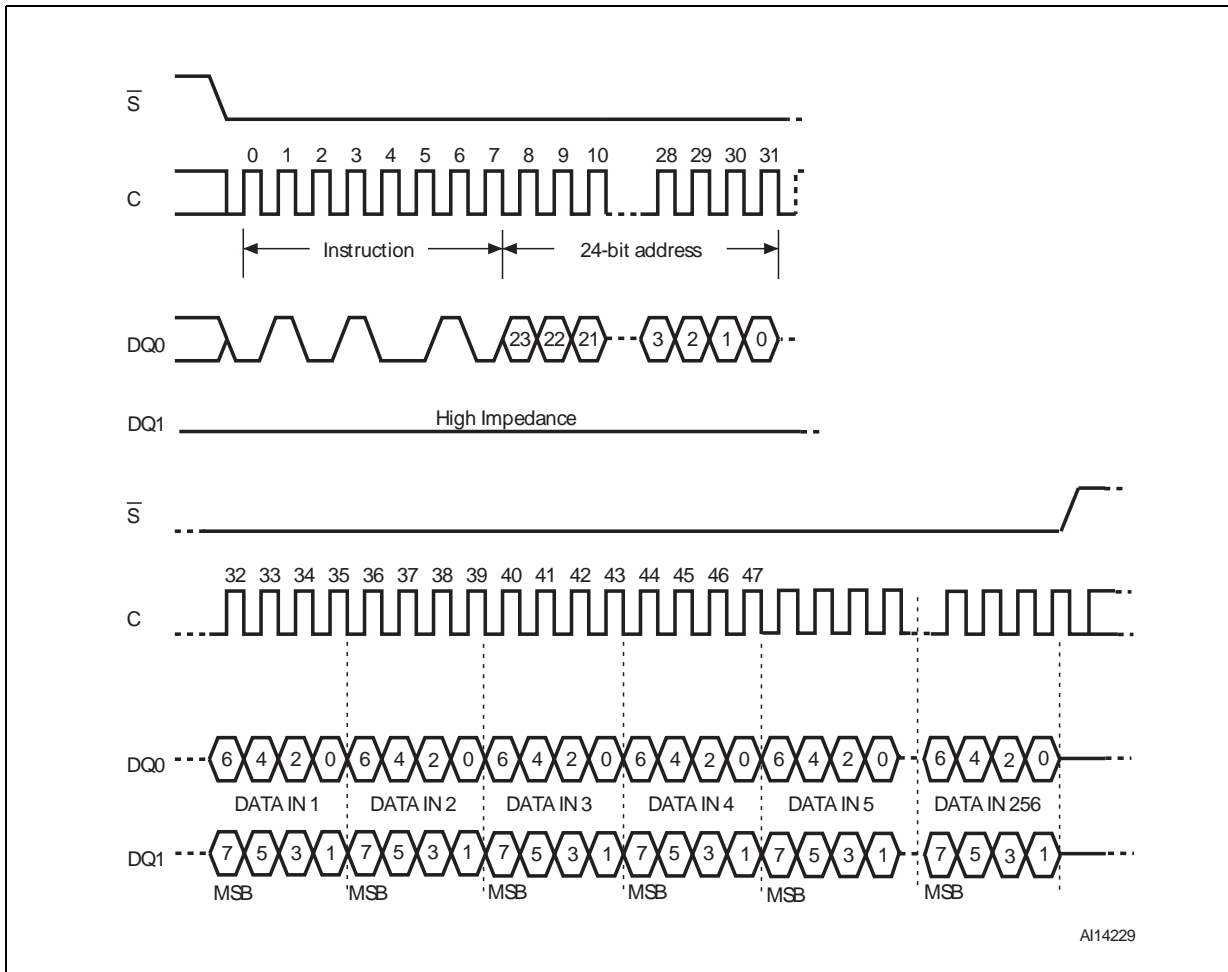

9.1.13 Dual Input Extended Fast Program

The Dual Input Extended Fast Program (DIEFP) instruction is very similar to the Dual Input Fast Program (DIFP), except that the address bits are shifted in on two pins (pin DQ0 and pin DQ1) instead of only one.

Figure 22. Dual Input Extended Fast Program instruction sequence

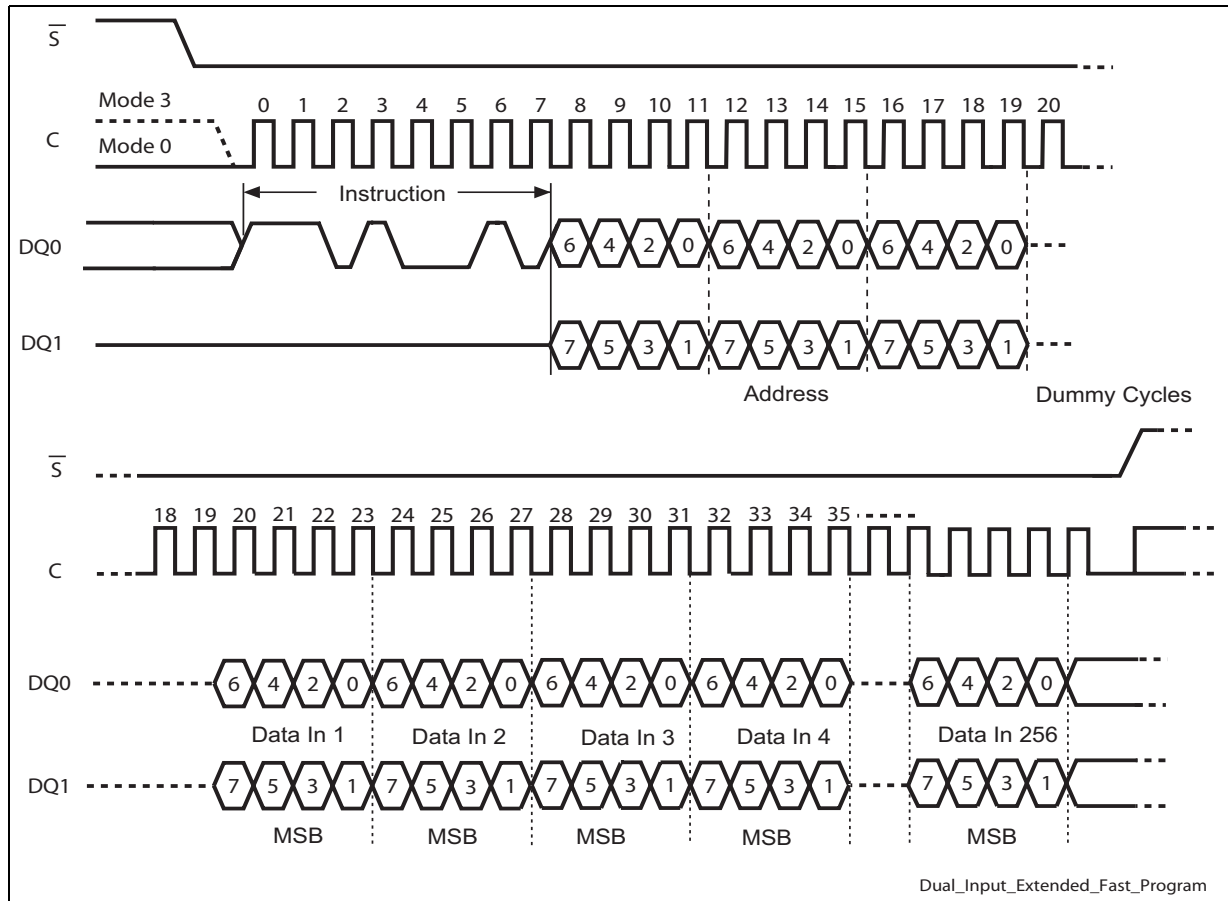

9.1.14 Quad Input Fast Program

The Quad Input Fast Program (QIFP) instruction is very similar to the Dual Input Fast Program (DIFP) instruction, except that the data are entered on four pins (pin DQ0, pin DQ1, pin W/VPP/DQ2 and pin HOLD/ (DQ3) instead of only two. Inputting the data on four pins instead of two doubles the data transfer bandwidth compared to the Dual Input Fast Program (DIFP) instruction.

The Quad Input Fast Program (QIFP) instruction is entered by driving Chip Select (\bar{S}) Low, followed by the instruction code, three address bytes and at least one data byte on Serial Data input (DQ0).

If the 8 least significant address bits (A7-A0) are not all zero, all transmitted data that goes beyond the end of the current page are programmed from the start address of the same page (from the address whose 8 least significant bits (A7-A0) are all zero). Chip Select (\bar{S}) must be driven Low for the entire duration of the sequence.

If more than 256 bytes are sent to the device, previously latched data are discarded and the last 256 data bytes are guaranteed to be programmed correctly within the same page. If less than 256 data bytes are sent to device, they are correctly programmed at the requested addresses without having any effects on the other bytes in the same page.

For optimized timings, it is recommended to use the Quad Input Fast Program (QIFP) instruction to program all consecutive targeted bytes in a single sequence rather to using several Quad Input Fast Program (QIFP) sequences each containing only a few bytes See [Table 33.: AC Characteristics](#).

Chip Select (\bar{S}) must be driven High after the eighth bit of the last data byte has been latched in, otherwise the Quad Input Fast Program (QIFP) instruction is not executed.

As soon as Chip Select (\bar{S}) is driven High, the self-timed Page Program cycle (whose duration is t_{PP}) is initiated. While the Quad Input Fast Program (QIFP) cycle is in progress, the Status Register may be read to check the value of the Write In Progress (WIP) bit. The Write In Progress (WIP) bit is 1 during the self-timed Page Program cycle, and 0 when it is completed. At some unspecified time before the cycle is completed, the Write Enable Latch (WEL) bit is reset.

A Quad Input Fast Program (QIFP) instruction applied to a page that is protected by the Block Protect (BP3, BP2, BP1, BP0 and TB) bits is not executed.

A Quad Input Fast Program cycle can be paused by mean of Program/Erase Suspend (PES) instruction and resumed by mean of Program/Erase Resume (PER) instruction.

Figure 23. Quad Input Fast Program instruction sequence

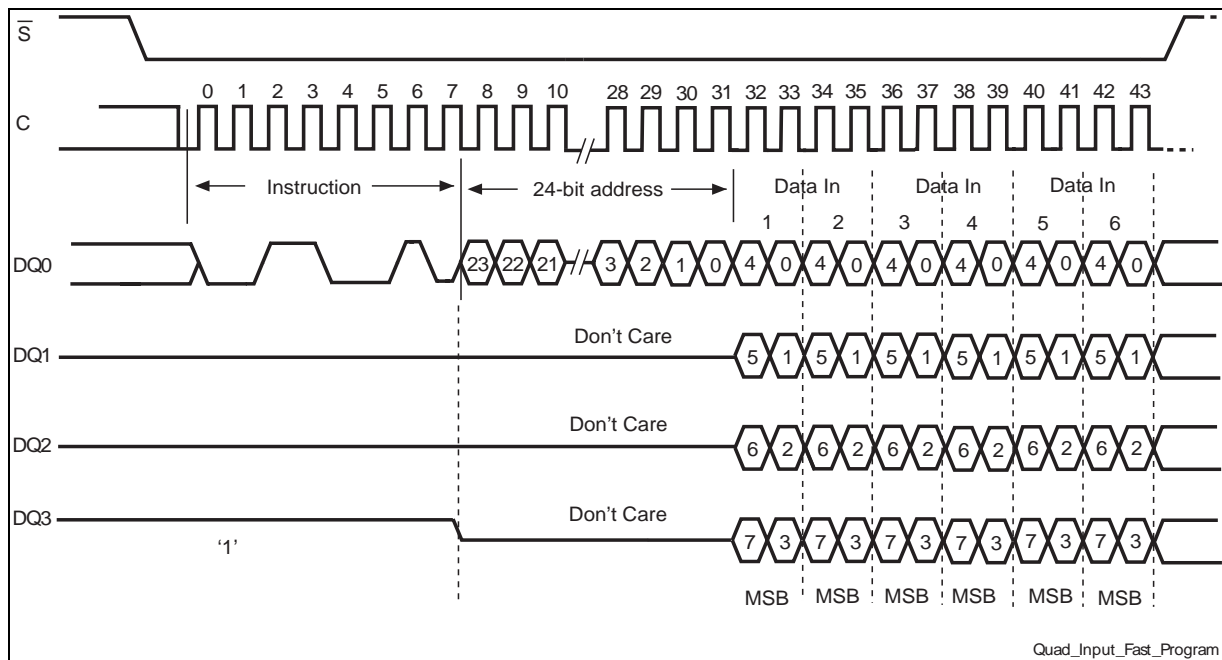

9.1.15 Quad Input Extended Fast Program

The Quad Input Extended Fast Program (QIEFP) instruction is very similar to the Quad Input Extended Fast Program (QIFP), except that the address bits are shifted in on four pins (pin DQ0, pin DQ1, pin W/VPP/DQ2 and pin HOLD/DQ3) instead of only one.

Figure 24. Quad Input Extended Fast Program instruction sequence

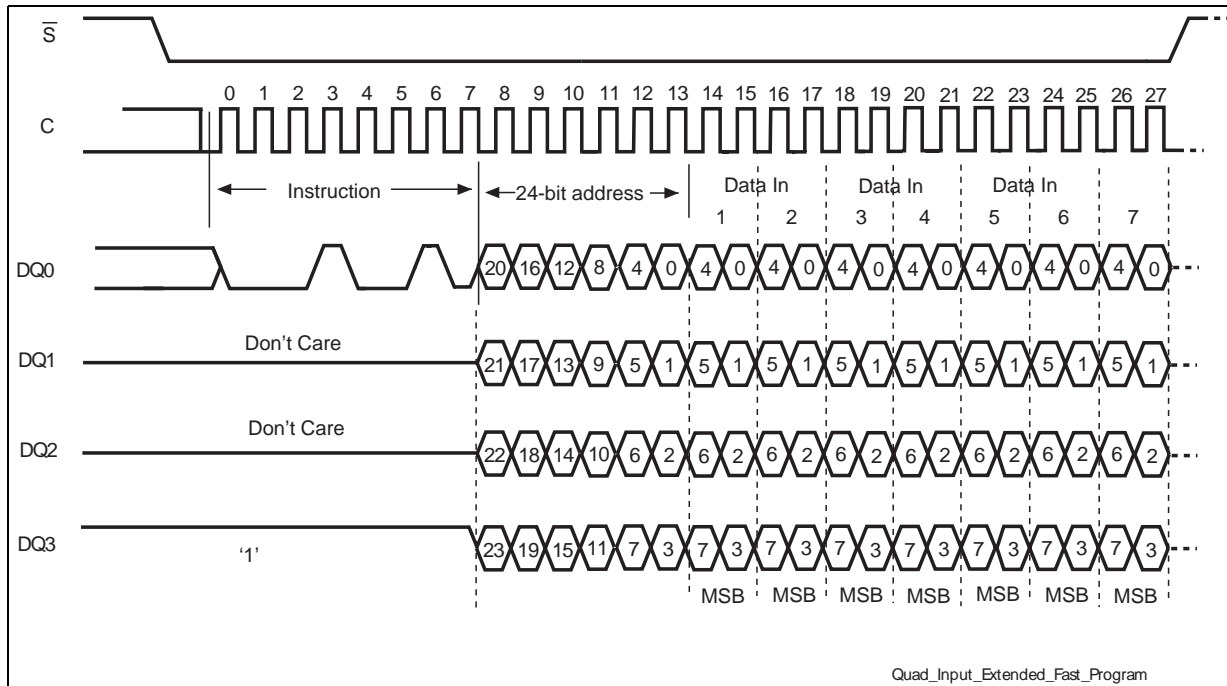

9.1.16 Program OTP instruction (POTP)

The Program OTP instruction (POTP) is used to program at most 64 bytes to the OTP memory area (by changing bits from 1 to 0, only). Before it can be accepted, a Write Enable (WREN) instruction must previously have been executed. After the Write Enable (WREN) instruction has been decoded, the device sets the Write Enable Latch (WEL) bit.

The Program OTP instruction is entered by driving Chip Select (\overline{S}) Low, followed by the instruction opcode, three address bytes and at least one data byte on Serial Data input (DQ0). Chip Select (\overline{S}) must be driven High after the eighth bit of the last data byte has been latched in, otherwise the Program OTP instruction is not executed.

There is no rollover mechanism with the Program OTP (POTP) instruction. This means that the Program OTP (POTP) instruction must be sent with a maximum of 65 bytes to program, once all 65 bytes have been latched in, any following byte will be discarded.

As soon as Chip Select (\overline{S}) is driven High, the self-timed Page Program cycle (whose duration is t_{PP}) is initiated. While the Program OTP cycle is in progress, the Status Register may be read to check the value of the Write In Progress (WIP) bit. The Write In Progress (WIP) bit is 1 during the self-timed Program OTP cycle, and it is 0 when it is completed. At some unspecified time before the cycle is complete, the Write Enable Latch (WEL) bit is reset.

To lock the OTP memory:

Bit 0 of the OTP control byte, that is byte 64, is used to permanently lock the OTP memory array.

- When bit 0 of byte 64 = '1', the 64 bytes of the OTP memory array can be programmed.
- When bit 0 of byte 64 = '0', the 64 bytes of the OTP memory array are read-only and cannot be programmed anymore.

Once a bit of the OTP memory has been programmed to '0', it can no longer be set to '1'. Therefore, as soon as bit 0 of byte 64 (control byte) is set to '0', the 64 bytes of the OTP memory array become read-only in a permanent way. Any Program OTP (POTP) instruction issued while an Erase, Program or Write cycle is in progress is rejected without having any effect on the cycle that is in progress.

Figure 25. Program OTP instruction sequence

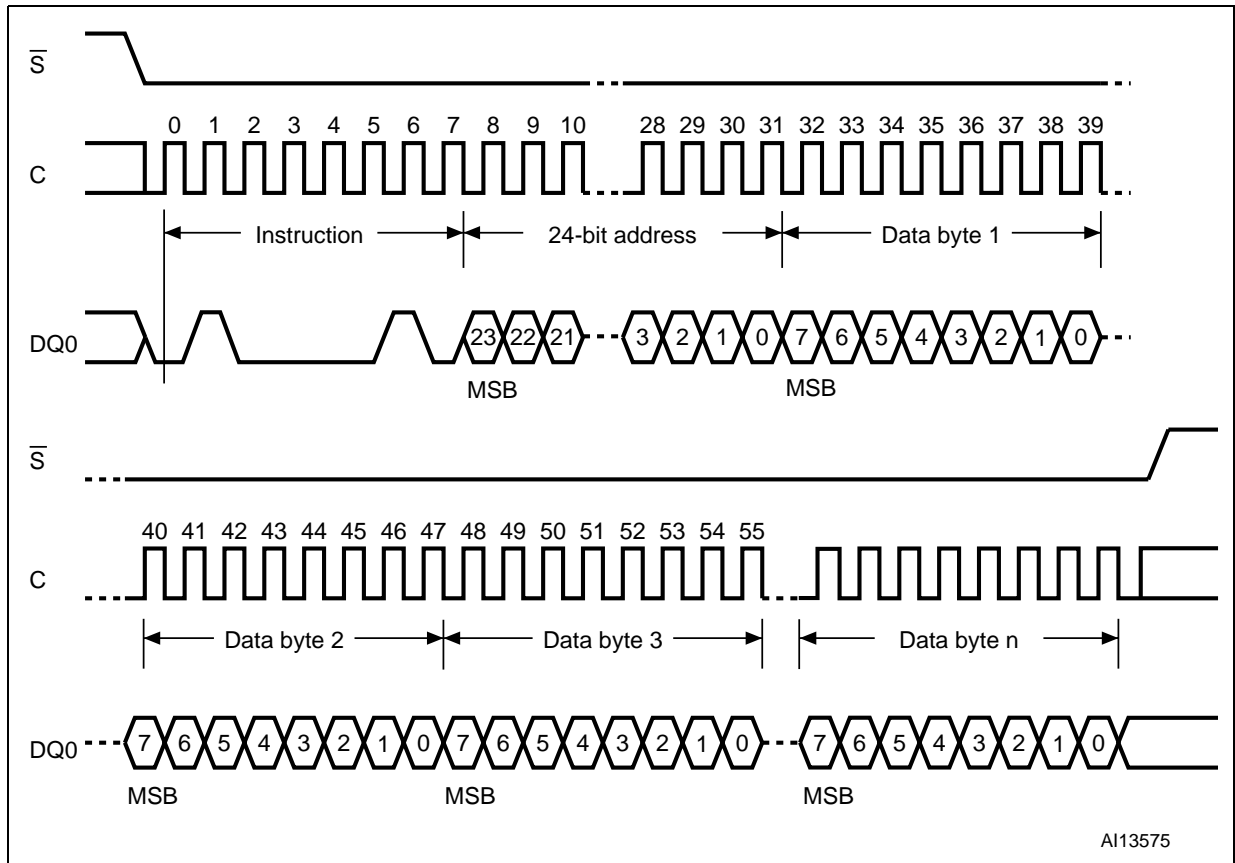

A113575

Figure 26. How to permanently lock the OTP bytes

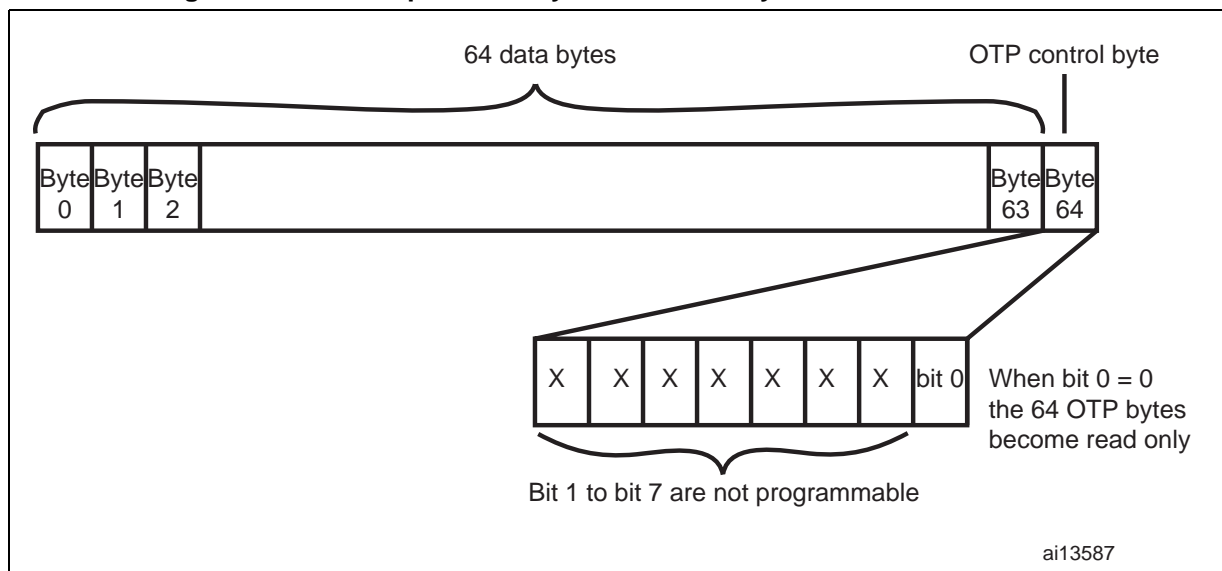

9.1.17 Subsector Erase (SSE)

For devices with bottom or top architecture, at the bottom (or top) of the addressable area there are 8 boot sectors, each one having 16 4Kbytes subsectors. The Subsector Erase (SSE) instruction sets to '1' (FFh) all bits inside the chosen subsector. Before it can be accepted, a Write Enable (WREN) instruction must previously have been executed. After the Write Enable (WREN) instruction has been decoded, the device sets the Write Enable Latch (WEL).

The Subsector Erase (SSE) instruction is entered by driving Chip Select (\bar{S}) Low, followed by the instruction code, and three address bytes on Serial Data input (DQ0). Any address inside the subsector is a valid address for the Subsector Erase (SSE) instruction. Chip Select (\bar{S}) must be driven Low for the entire duration of the sequence.

Chip Select (\bar{S}) must be driven High after the eighth bit of the last address byte has been latched in, otherwise the Subsector Erase (SSE) instruction is not executed. As soon as Chip Select (\bar{S}) is driven High, the self-timed Subsector Erase cycle (whose duration is t_{SSE}) is initiated. While the Subsector Erase cycle is in progress, the Status Register may be read to check the value of the Write In Progress (WIP) bit. The Write In Progress (WIP) bit is 1 during the self-timed Subsector Erase cycle, and is 0 when it is completed. At some unspecified time before the cycle is complete, the Write Enable Latch (WEL) bit is reset.

A Subsector Erase (SSE) instruction issued to a sector that is hardware or software protected, is not executed.

Any Subsector Erase (SSE) instruction, while an Erase, Program or Write cycle is in progress, is rejected without having any effects on the cycle that is in progress.

Any Subsector Erase (SSE) instruction in devices with uniform architecture (meaning no boot sectors with subsectors) is rejected without having any effects on the device.

Figure 27. Subsector Erase instruction sequence

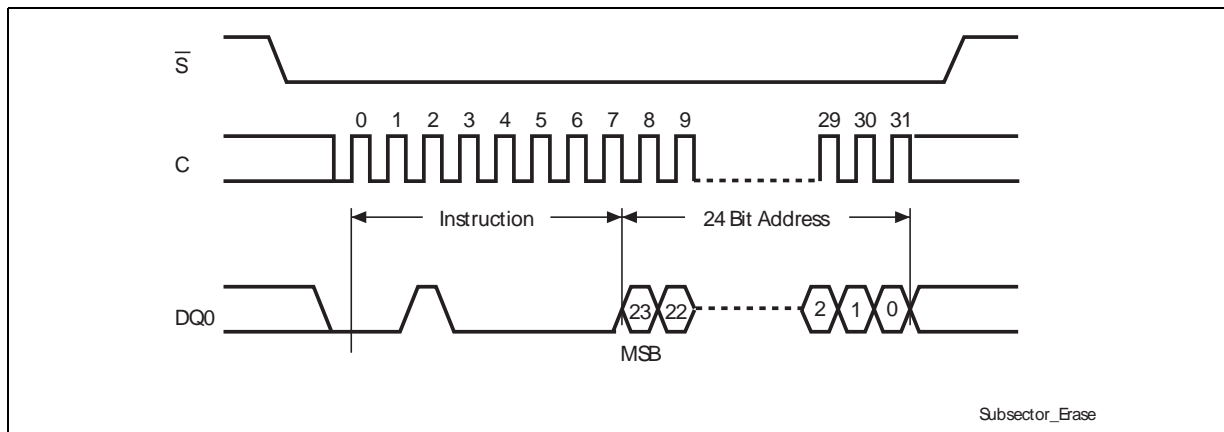

9.1.18 Sector Erase (SE)

The Sector Erase (SE) instruction sets to '1' (FFh) all bits inside the chosen sector. Before it can be accepted, a Write Enable (WREN) instruction must previously have been executed.

After the Write Enable (WREN) instruction has been decoded, the device sets the Write Enable Latch (WEL).

The Sector Erase (SE) instruction is entered by driving Chip Select (\bar{S}) Low, followed by the instruction code, and three address bytes on Serial Data input (DQ0). Any address inside the sector is a valid address for the Sector Erase (SE) instruction. Chip Select (\bar{S}) must be driven Low for the entire duration of the sequence.

Chip Select (\bar{S}) must be driven High after the eighth bit of the last address byte has been latched in, otherwise the Sector Erase (SE) instruction is not executed. As soon as Chip Select (\bar{S}) is driven High, the self-timed Sector Erase cycle (whose duration is t_{SE}) is initiated. While the Sector Erase cycle is in progress, the Status Register may be read to check the value of the Write In Progress (WIP) bit. The Write In Progress (WIP) bit is 1 during the self-timed Sector Erase cycle, and is 0 when it is completed. At some unspecified time before the cycle is completed, the Write Enable Latch (WEL) bit is reset.

A Sector Erase (SE) instruction applied to a page which is protected by the Block Protect (BP3, BP2, BP1, BP0 and TB) bits is not executed.

A Sector Erase cycle can be paused by mean of Program/Erase Suspend (PES) instruction and resumed by mean of Program/Erase Resume (PER) instruction.

Figure 28. Sector Erase instruction sequence

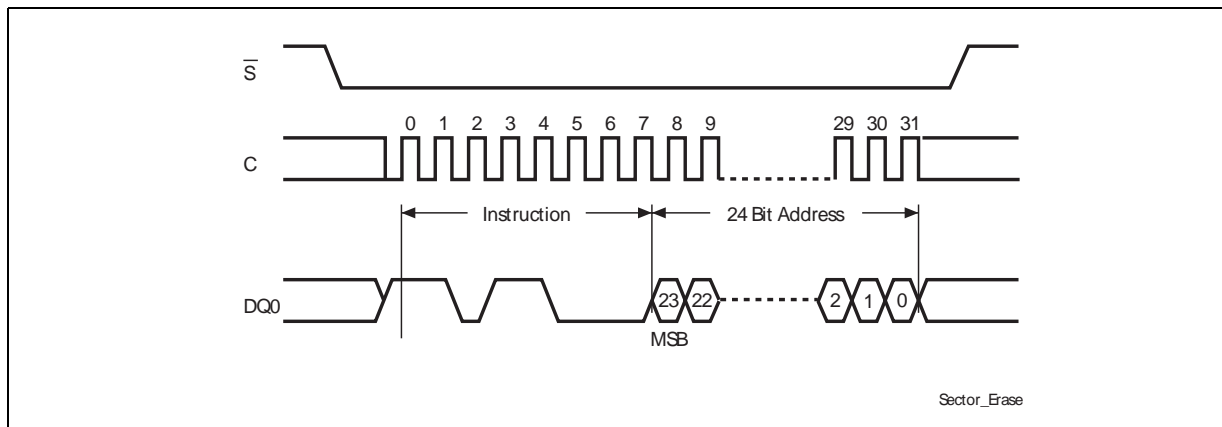

9.1.19 Bulk Erase (BE)

The Bulk Erase (BE) instruction sets all bits to '1' (FFh). Before it can be accepted, a Write Enable (WREN) instruction must previously have been executed. After the Write Enable (WREN) instruction has been decoded, the device sets the Write Enable Latch (WEL).

The Bulk Erase (BE) instruction is entered by driving Chip Select (\bar{S}) Low, followed by the instruction code on Serial Data input (DQ0). Chip Select (\bar{S}) must be driven Low for the entire duration of the sequence.

Chip Select (\bar{S}) must be driven High after the eighth bit of the instruction code has been latched in, otherwise the Bulk Erase instruction is not executed. As soon as Chip Select (\bar{S}) is driven High, the self-timed Bulk Erase cycle (whose duration is tBE) is initiated. While the Bulk Erase cycle is in progress, the Status Register may be read to check the value of the Write In Progress (WIP) bit. The Write In Progress (WIP) bit is 1 during the self-timed Bulk Erase cycle, and is 0 when it is completed. At some unspecified time before the cycle is completed, the Write Enable Latch (WEL) bit is reset.

The Bulk Erase (BE) instruction is executed only if all Block Protect (BP3, BP2, BP1, BP0) bits are 0. The Bulk Erase (BE) instruction is ignored if one, or more, sectors are protected.

Figure 29. Bulk Erase instruction sequence

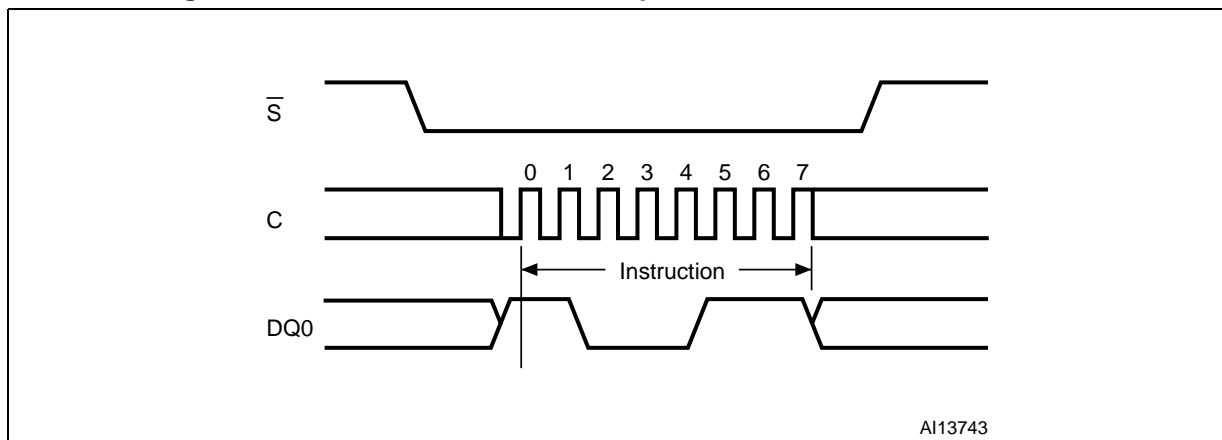

9.1.20 Program/Erase Suspend

The Program/Erase Suspend instruction allows the controller to interrupt a Program or an Erase instruction, in particular: Sector Erase, Subsector Erase, Page Program, Dual Input Page Program, Dual Input Extended Page program, Quad Input Page Program and Quad Input Extended Page program can be suspended and erased.

Note: Bulk Erase, Write Non Volatile Configuration register and Program OTP cannot be suspended.

After a Program/Erase Suspend instruction the bit 2 of the Flag Status register is immediately set to 1 and, after a latency time, both the WIP bit of the Status Register and the Program/Erase controller bit (Not WIP) of the Flag Status Register are cleared (to 0 and to 1 respectively).

The Suspended state is reset if a power-off is performed or after resume.

After a sector erase instruction has been suspended, another erase instruction is not allowed; however, it is possible to perform program and reading instructions on all the sectors except the one whose erase cycle is suspended. Any read instruction issued on this sector outputs Don't Care data.

After a subsector erase instruction has been suspended, neither an erase instruction or a program instruction is allowed; only a read instruction is allowed on all sectors except the one containing the subsector whose erase cycle is suspended. Any read instruction issued on this sector outputs Don't Care data.

After a program instruction has been suspended, neither a program instruction or an erase instructions is allowed; however, it is possible to perform a read instruction on all pages except the one whose program cycle is suspended. Any read instruction issued on this page outputs Don't Care data.

It's possible to nest a suspend instruction inside another suspended one just once, meaning that it's possible for example to send to the device an erase instruction, then suspend it, then send a program instruction and in the end suspend it as well. In this case the next Program/Erase Resume Instruction resumes the more recent suspended modify cycles, another Program/Erase Resume Instruction is need to resume also the former one.

Table 18. Suspend Parameters

Parameter	Condition	Typ	Max	Unit	Note
Erase to Suspend	Sector Erase or Erase Resume to Erase Suspend	40		μs	Timing not internally controlled
Program to Suspend	Program Resume to Program Suspend	5		μs	Timing not internally controlled
SSErase to Suspend	Sub Sector Erase or Sub Sector Erase Resume to Erase Suspend	40		μs	Timing not internally controlled
Suspend Latency	Program	7		μs	Any Read instruction accepted
	Sub Sector Erase	15		μs	Any Read instruction accepted
	Erase	15		μs	Any instruction accepted but DP, SE, SSE, BE, WRSR, WRNVCR, POTP

Table 19. Operations Allowed / Disallowed During Device States

Operation	Device States and Sector (Same/Other) in Which Operation is Allowed/Disallowed (Yes/No)											
	Standby State		Program State		Erase State (SE/SSE)		Subsector Erase Suspended State		Program Suspended State		Erase Suspended State	
	Sector		Sector		Sector		Sector		Sector		Sector	
	Same	Other	Same	Other	Same	Other	Same	Other	Same	Other	Same	Other
All Reads except RDSR / RDFSR	Yes	Yes	No	No	No	No	Yes ⁽¹⁾	Yes	Yes	Yes	Yes ⁽¹⁾	Yes
Array Program: PP / DIFP / QWIFP / DIEFP / QIEFP	Yes	Yes	No	No	No	No	No	No	No	No	No	Yes
Sector Erase	Yes	Yes	No	No	No	No	No	No	No	No	No	No
Sub-Sector Erase	Yes	Yes	No	No	No	No	No	No	No	No	No	No
WRLR / POTP / BE / WRSR / WRNVCR	Yes		No		No		No		No		No	
WVCR / WVECR	Yes		No		No		Yes		Yes		Yes	
RDSR / RDFSR	Yes		Yes		Yes		Yes		Yes		Yes	
Program / Erase Suspend	No		Yes		Yes		No		No		No	

1. The Read operation is accepted but the data output is not guaranteed until the program or erase has completed.

Note: The device can be in only one state at a time, such as Standby, Program, Erase, and so on. Device states are shown in [Table 19.: Operations Allowed / Disallowed During Device States](#).

9.1.21 Program/Erase Resume

After a Program/Erase suspend instruction, a Program/Erase Resume instruction is required to continue performing the suspended Program or Erase sequence. Program/Erase Resume instruction is ignored if the device is not in a Program/Erase Suspended status. The WIP bit of the Status Register and Program/Erase controller bit (Not WIP) of the Flag Status Register both switch to the busy state (1 and 0 respectively) after Program/Erase Resume instruction until the Program or Erase sequence is completed.

In this case the next Program/Erase Resume Instruction resumes the more recent suspended modify cycles, another Program/Erase Resume Instruction is need to resume also the former one.

9.1.22 Read Status Register (RDSR)

The Read Status Register (RDSR) instruction allows the Status Register to be read. The Status Register may be read at any time, even while a Program, Erase or Write Status Register cycle is in progress. When one of these cycles is in progress, it is recommended to check the Write In Progress (WIP) bit (or the Program/Erase controller bit of the Flag Status Register) before sending a new instruction to the device. It is also possible to read the Status Register continuously, as shown here.

Figure 30. Read Status Register instruction sequence

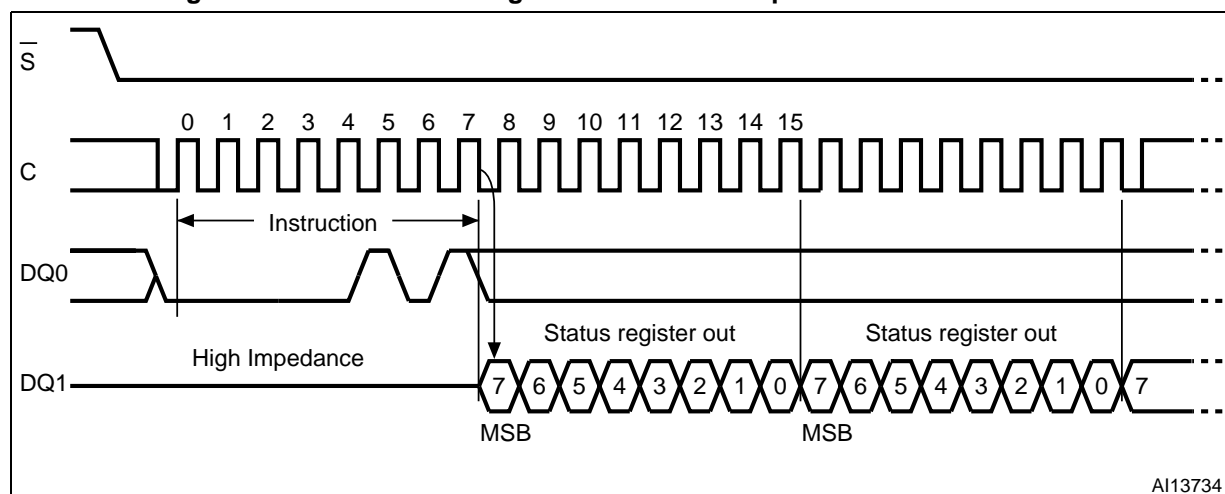

9.1.23 Write status register (WRSR)

The write status register (WRSR) instruction allows new values to be written to the status register. Before it can be accepted, a write enable (WREN) instruction must previously have been executed. After the write enable (WREN) instruction has been decoded and executed, the device sets the write enable latch (WEL).

The write status register (WRSR) instruction is entered by driving Chip Select (\bar{S}) Low, followed by the instruction code and the data byte on serial data input (DQ0).

The write status register (WRSR) instruction has no effect on b1 and b0 of the status register.

Chip Select (\bar{S}) must be driven High after the eighth bit of the data byte has been latched in. If not, the write status register (WRSR) instruction is not executed. As soon as Chip Select (\bar{S}) is driven High, the self-timed write status register cycle (whose duration is t_{ow}) is initiated. While the write status register cycle is in progress, the status register may still be read to check the value of the write in progress (WIP) bit. The write in progress (WIP) bit is 1 during the self-timed write status register cycle, and is 0 when it is completed. When the cycle is completed, the write enable latch (WEL) is reset.

The write status register (WRSR) instruction allows the user to change the values of the block protect (BP3, BP2, BP1, BP0) bits, to define the size of the area that is to be treated as read-only, as defined in Table 3. The write status register (WRSR) instruction also allows the user to set and reset the status register write disable (SRWD) bit in accordance with the Write Protect (W/VPP) signal. The status register write disable (SRWD) bit and Write Protect (W/VPP) signal allow the device to be put in the hardware protected mode (HPM). The write

status register (WRSR) instruction is not executed once the hardware protected mode (HPM) is entered.

Figure 31. Write Status Register instruction sequence

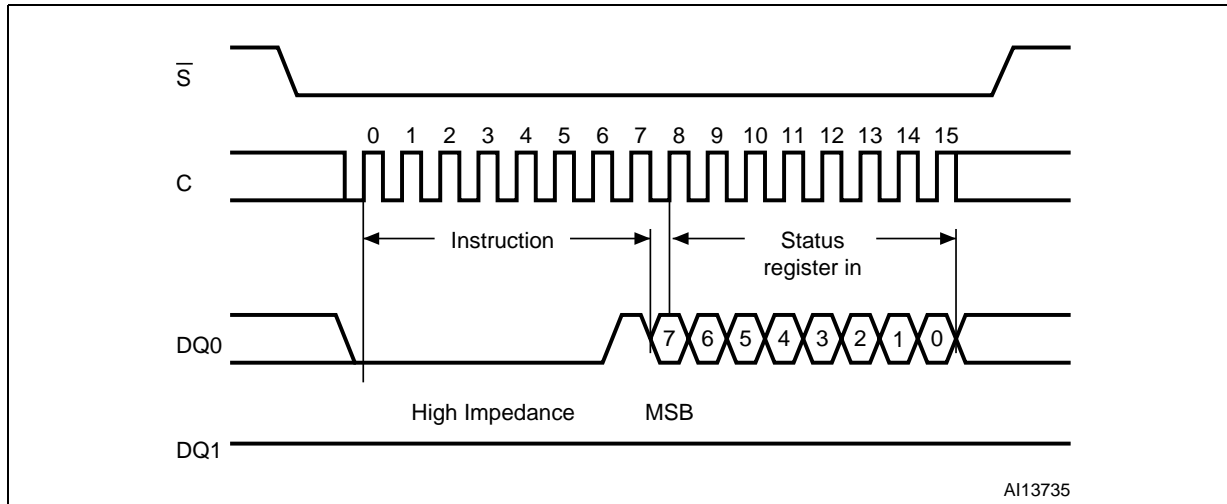

The protection features of the device are summarized in Table 8.

When the Status Register Write Disable (SRWD) bit of the Status Register is 0 (its initial delivery state), it is possible to write to the Status Register provided that the Write Enable Latch (WEL) bit has previously been set by a Write Enable (WREN) instruction, regardless of whether Write Protect ($\overline{W/VPP}$) is driven High or Low.

When the Status Register Write Disable (SRWD) bit of the Status Register is set to '1', two cases need to be considered, depending on the state of Write Protect ($\overline{W/VPP}$):

- If Write Protect ($\overline{W/VPP}$) is driven High, it is possible to write to the Status Register provided that the Write Enable Latch (WEL) bit has previously been set by a Write Enable (WREN) instruction.
- If Write Protect ($\overline{W/VPP}$) is driven Low, it is not possible to write to the Status Register even if the Write Enable Latch (WEL) bit has previously been set by a Write Enable (WREN) instruction (attempts to write to the Status Register are rejected, and are not accepted for execution). As a consequence, all the data bytes in the memory area that are software protected (SPM) by the Block Protect (BP3, BP2, BP1, BP0) bits of the Status Register, are also hardware protected against data modification.

Regardless of the order of the two events, the Hardware Protected mode (HPM) can be entered in either of the following ways:

- setting the Status Register Write Disable (SRWD) bit after driving Write Protect ($\overline{W/VPP}$) Low
- driving Write Protect ($\overline{W/VPP}$) Low after setting the Status Register Write Disable (SRWD) bit.

The only way to exit the Hardware Protected mode (HPM) once entered is to pull Write Protect ($\overline{W/VPP}$) High.

If Write Protect ($\overline{W/VPP}$) is permanently tied High, the Hardware Protected mode (HPM) can never be activated, and only the Software Protected mode (SPM), using the Block Protect (BP3, BP2, BP1, BP0) bits of the Status Register, can be used.

Table 20. Protection modes

\overline{W}/VPP Signal	SRWD bit	Mode	Write protection of the status register	Memory content	
				Protected area ⁽¹⁾	Unprotected area ⁽¹⁾
1	0	Software protected (SPM)	Status register is writeable, if the WREN instruction has set the WEL bit. The values in the SRWD, TB, BP3, BP2, BP1, and BP0 bits can be changed.	Protected against PP, DIFP, DIEFP, QIFP, QIEFP, SSE, SE and BE instructions.	Ready to accept PP, DIFP, DIEFP, QIFP, QIEFP, SSE, and SE instructions.
0	0				
1	1				
0	1	Hardware protected (HPM)	Status Register is hardware write protected. The values in the SRWD, TB, BP3, BP2, BP1 and BP0 bits cannot be changed	PP, DIFP, DIEFP, QIFP, QIEFP, SSE, SE and BE instructions.	PP, DIFP, DIEFP, QIFP, QIEFP, SSE, and SE instructions.

1. As defined by the values in the Block Protect (TB, BP3, BP2, BP1, BP0) bits of the Status Register, as shown in [Table 3: Status register format](#).

9.1.24 Read Lock Register (RDLR)

The device is first selected by driving Chip Select (\overline{S}) Low. The instruction code for the Read Lock Register (RDLR) instruction is followed by a 3-byte address (A23-A0) pointing to any location inside the concerned sector. Each address bit is latched-in during the rising edge of Serial Clock (C). Then the value of the Lock Register is shifted out on Serial Data output (DQ1), each bit being shifted out, at a maximum frequency f_C , during the falling edge of Serial Clock (C).

The Read Lock Register (RDLR) instruction is terminated by driving Chip Select (\overline{S}) High at any time during data output.

Any Read Lock Register (RDLR) instruction, while an Erase, Program or Write cycle is in progress, is rejected without having any effects on the cycle that is in progress.

Figure 32. Read Lock Register instruction and data-out sequence

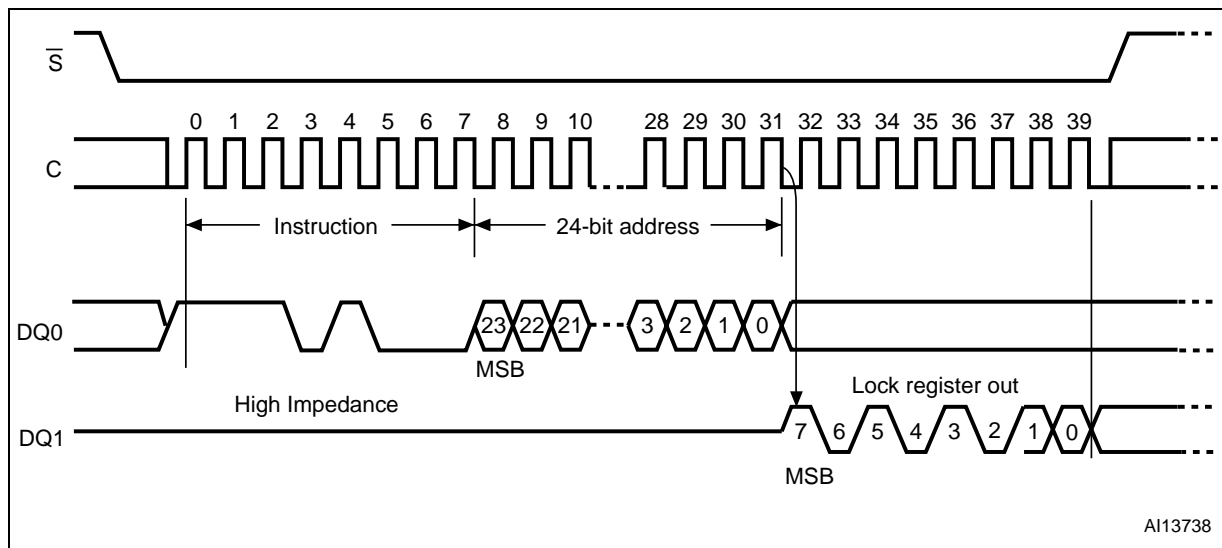

Table 21. Lock Register out⁽¹⁾

Bit	Bit name	Value	Function
b7-b2	Reserved		
b1	Sector Lock Down	'1'	The Write Lock and Lock Down bits cannot be changed. Once a '1' is written to the Lock Down bit it cannot be cleared to '0', except by a power-up.
		'0'	The Write Lock and Lock Down bits can be changed by writing new values to them.
b0	Sector Write Lock	'1'	Write, Program and Erase operations in this sector will not be executed. The memory contents will not be changed.
		'0'	Write, Program and Erase operations in this sector are executed and will modify the sector contents.

1. Values of (b1, b0) after power-up are defined in [Section 7: Protection modes](#).

9.1.25 Write to Lock Register (WRLR)

The Write to Lock Register (WRLR) instruction allows bits to be changed in the Lock Registers. Before it can be accepted, a Write Enable (WREN) instruction must previously have been executed. After the Write Enable (WREN) instruction has been decoded, the device sets the Write Enable Latch (WEL).

The Write to Lock Register (WRLR) instruction is entered by driving Chip Select (\bar{S}) Low, followed by the instruction code, three address bytes (pointing to any address in the targeted sector and one data byte on Serial Data input (DQ0). The instruction sequence is shown in Figure 22. Chip Select (\bar{S}) must be driven High after the eighth bit of the data byte has been latched in, otherwise the Write to Lock Register (WRLR) instruction is not executed.

Lock Register bits are volatile, and therefore do not require time to be written. When the Write to Lock Register (WRLR) instruction has been successfully executed, the Write Enable Latch (WEL) bit is reset after a delay time less than t_{SHSL} minimum value.

Any Write to Lock Register (WRLR) instruction, while an Erase, Program or Write cycle is in progress, is rejected without having any effects on the cycle that is in progress.

Figure 33. Write to Lock Register instruction sequence

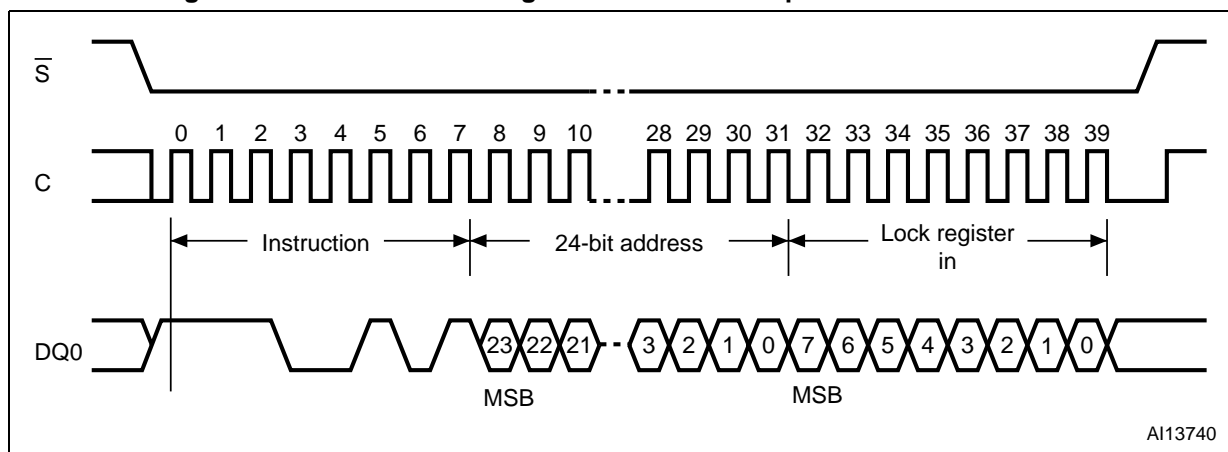

Table 22. Lock Register in⁽¹⁾

Sector	Bit	Value
All sectors	b7-b2	'0'
	b1	Sector Lock Down bit value (refer to Table 21)
	b0	Sector Write Lock bit value (refer to Table 21)

1. Values of (b1, b0) after power-up are defined in [Section 7: Protection modes](#).

9.1.26 Read Flag Status Register

The Read Flag Status Register (RFSR) instruction allows the Flag Status Register to be read. The Status Register may be read at any time, even while a Program, Erase. When one of these cycles is in progress, it is recommended to check the P/E Controller bit (Not WIP) bit before sending a new instruction to the device. It is also possible to read the Flag Register continuously, as shown here.

Figure 34. Read Flag Status Register instruction sequence

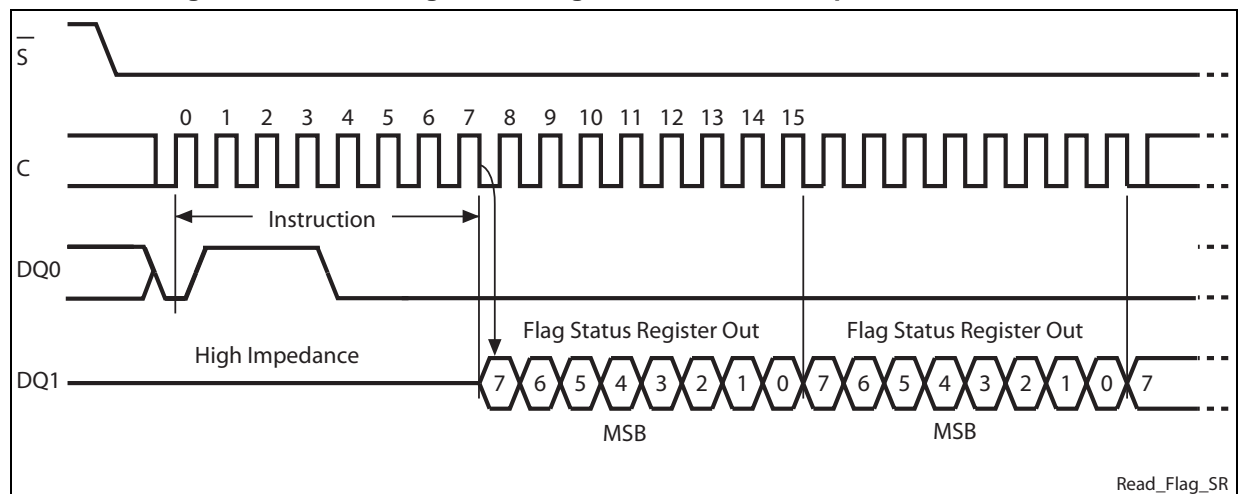

9.1.27 Clear Flag Status Register

The Clear Flag Status Register (CLFSR) instruction reset the error Flag Status Register bits (Erase Error bit, Program Error bit, VPP Error bit, Protection Error bit). It is not necessary to set the WEL bit before the Clear Flag Status Register instruction is executed. The WEL bit will be unchanged after this command is executed.

Figure 35. Clear Flag Status Register instruction sequence

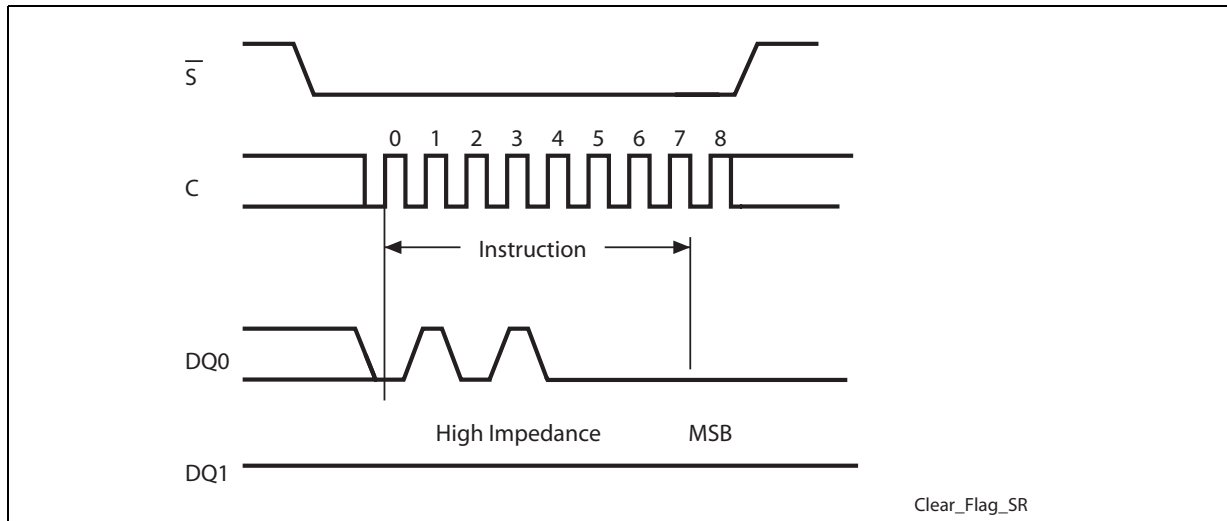

9.1.28 Read NV Configuration Register

The Read Non Volatile Configuration Register (RDNVCR) instruction allows the Non Volatile Configuration Register to be read.

Figure 36. Read NV Configuration Register instruction sequence

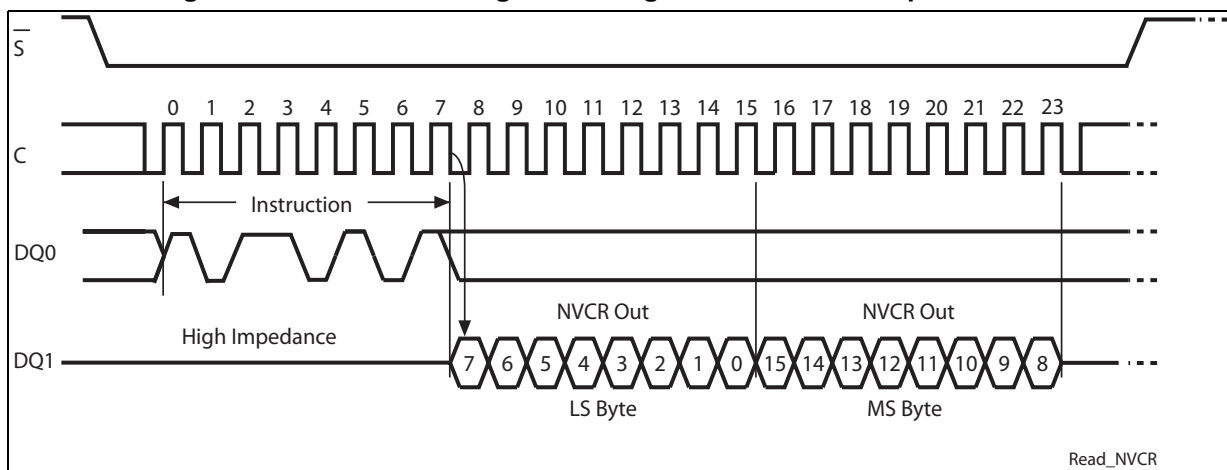

9.1.29 Write NV Configuration Register

The Write Non Volatile Configuration register (WRNVCR) instruction allows new values to be written to the Non Volatile Configuration register. Before it can be accepted, a write enable (WREN) instruction must previously have been executed. After the write enable (WREN) instruction has been decoded and executed, the device sets the write enable latch (WEL).

The Write Non Volatile Configuration register (WRNVCR) instruction is entered by driving Chip Select (\bar{S}) Low, followed by the instruction code and the data bytes on serial data input (DQ0).

Chip Select (\bar{S}) must be driven High after the 16th bit of the data bytes has been latched in. If not, the Write Non Volatile Configuration register (WRNVCR) instruction is not executed.

As soon as Chip Select (\overline{S}) is driven High, the self-timed write NV configuration register cycle (whose duration is *tnvcr*) is initiated.

While the Write Non Volatile Configuration register cycle is in progress, it is possible to monitor the end of the process by polling status Register write in progress (WIP) bit or the Flag Status Register Program/Erase Controller bit. The write in progress (WIP) bit is 1 during the self-timed Write Non Volatile Configuration register cycle, and is 0 when it is completed. When the cycle is completed, the write enable latch (WEL) is reset.

The Write Non Volatile Configuration register (WRNVCR) instruction allows the user to change the values of all the Non Volatile Configuration Register bits, described in [Table 4.: Non-Volatile Configuration Register](#).

The Write Non Volatile Configuration Register impacts the memory behavior only after the next power on sequence.

Figure 37. Write NV Configuration Register instruction sequence

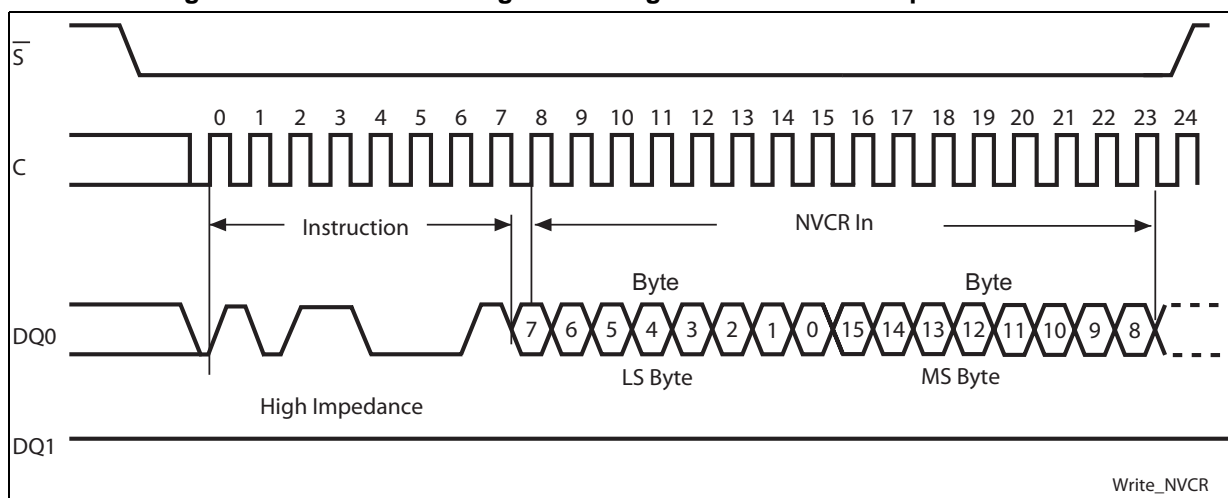

9.1.30 Read Volatile Configuration Register

The Read Volatile Configuration Register (RDVCR) instruction allows the Volatile Configuration Register to be read. See [Table 6.: Volatile Configuration Register](#).

Figure 38. Read Volatile Configuration Register instruction sequence

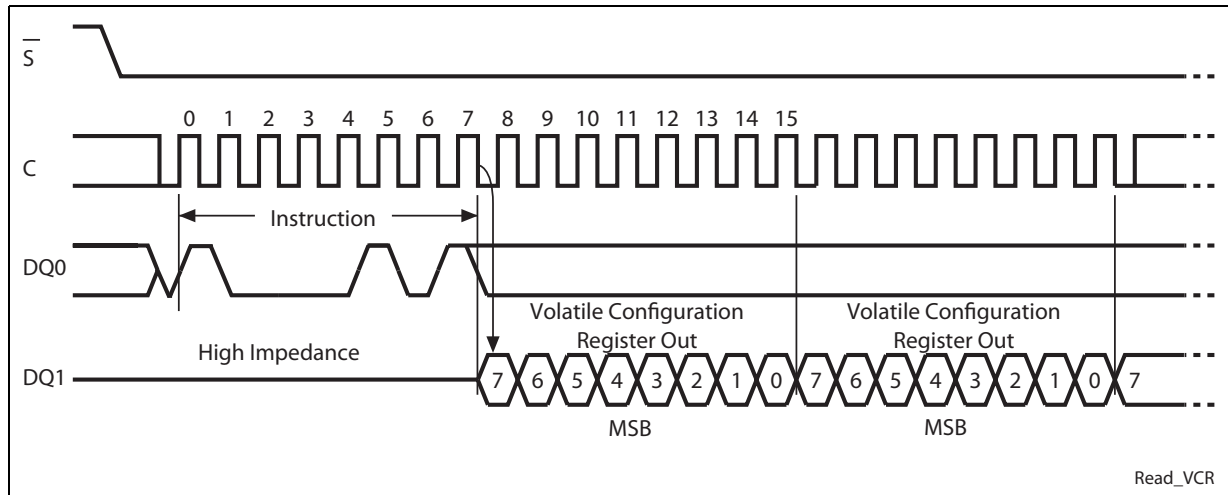

9.1.31 Write Volatile Configuration Register

The Write Volatile Configuration register (WRVCR) instruction allows new values to be written to the Volatile Configuration register. Before it can be accepted, a write enable (WREN) instruction must have been executed. After the write enable (WREN) instruction has been decoded and executed, the device sets the write enable latch (WEL).

In case of Fast POR (see section 11.1 for further details) the WREN instruction is not required because a WREN instruction gets the device out from the Fast POR state.

The Write Volatile Configuration register (WRVCR) instruction is entered by driving Chip Select (\overline{S}) Low, followed by the instruction code and the data byte on serial data input (DQ0).

Chip Select (\overline{S}) must be driven High after the eighth bit of the data byte has been latched in.

If not, the Write Volatile Configuration register (WRVCR) instruction is not executed.

When the new data are latched, the write enable latch (WEL) is reset.

The Write Volatile Configuration register (WRVCR) instruction allows the user to change the values of all the Volatile Configuration Register bits, described in [Table 6.: Volatile Configuration Register](#).

The Write Volatile Configuration Register impacts the memory behavior right after the instruction is received by the device.

Figure 39. Write Volatile Configuration Register instruction sequence

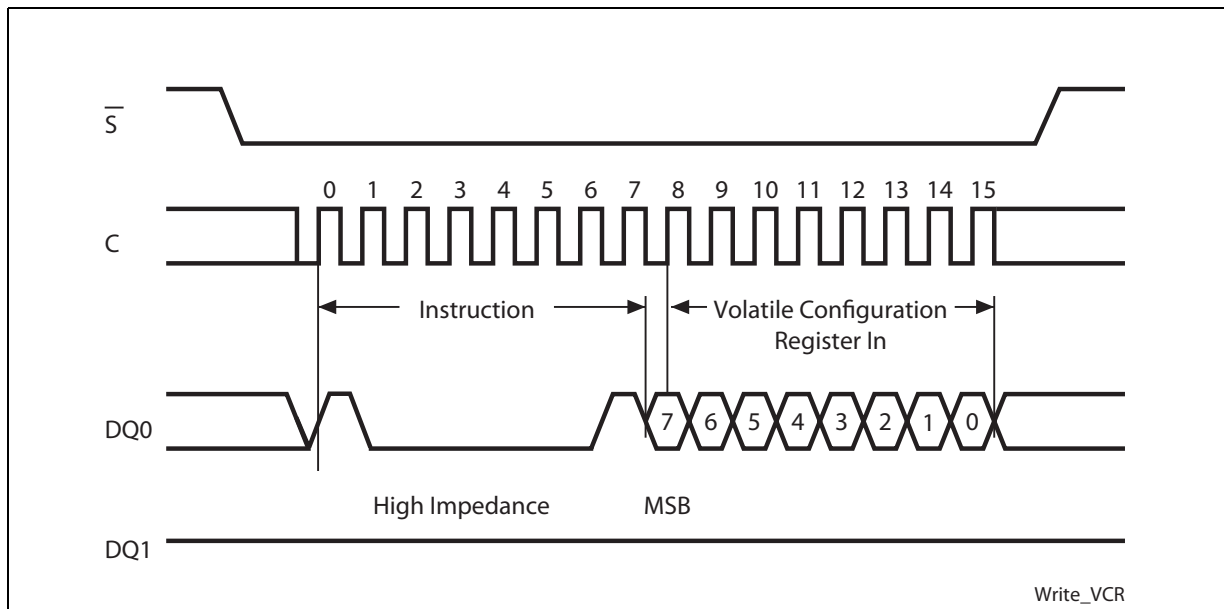

9.1.32 Read Volatile Enhanced Configuration Register

The Read Volatile Enhanced Configuration Register (RDVECR) instruction allows the Volatile Configuration Register to be read.

Figure 40. Read Volatile Enhanced Configuration Register instruction sequence

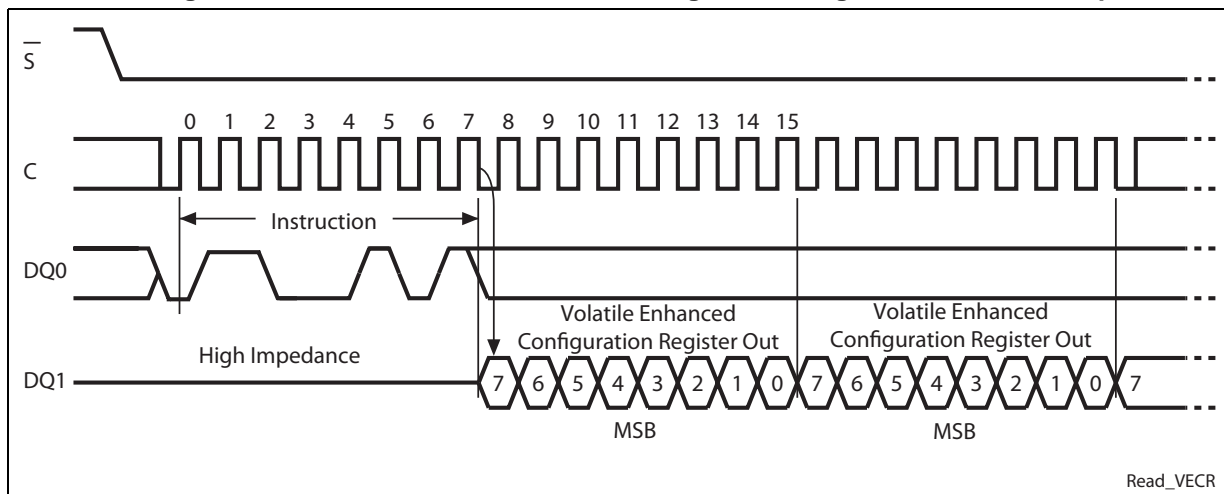

9.1.33 Write Volatile Enhanced Configuration Register

The Write Volatile Enhanced Configuration register (WRVECR) instruction allows new values to be written to the Volatile Enhanced Configuration register. Before it can be accepted, a write enable (WREN) instruction must previously have been executed. After the write enable (WREN) instruction has been decoded and executed, the device sets the write enable latch (WEL). In case of Fast POR, the WREN instruction is not required because a WREN instruction gets the device out from the Fast POR state (see [Section 11.1: Fast POR](#)).

The Write Volatile Enhanced Configuration register (WRVECR) instruction is entered by driving Chip Select (\bar{S}) Low, followed by the instruction code and the data byte on serial data input (DQ0).

Chip Select (\bar{S}) must be driven High after the eighth bit of the data byte has been latched in.

If not, the Write Volatile Enhanced Configuration register (WRVECR) instruction is not executed.

When the new data are latched, the write enable latch (WEL) is reset.

The Write Volatile Enhanced Configuration register (WRVECR) instruction allows the user to change the values of all the Volatile Enhanced Configuration Register bits, described in [Table 7.: Volatile Enhanced Configuration Register](#).

The Write Volatile Enhanced Configuration Register impacts the memory behavior right after the instruction is received by the device.

Figure 41. Write Volatile Enhanced Configuration Register instruction sequence

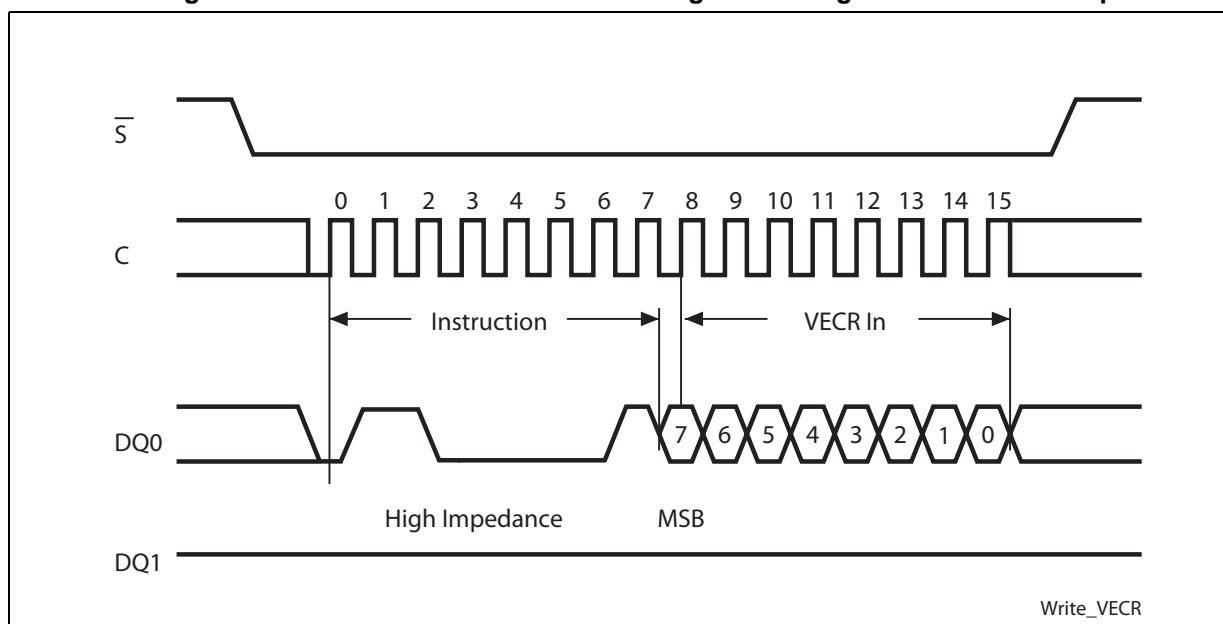

9.1.34 Deep Power-down (DP)

Executing the Deep Power-down (DP) instruction is the only way to put the device in the lowest consumption mode (the Deep Power-down mode). It can also be used as a software protection mechanism, while the device is not in active use, as in this mode, the device ignores all Write, Program and Erase instructions.

Driving Chip Select (\bar{S}) High deselects the device, and puts the device in the Standby Power mode (if there is no internal cycle currently in progress). But this mode is not the Deep Power-down mode. The Deep Power-down mode can only be entered by executing the Deep Power-down (DP) instruction, subsequently reducing the standby current (from I_{CC1} to I_{CC2} , as specified in [Table 32](#)).

To take the device out of Deep Power-down mode, the Release from Deep Power-down (RDP) instruction must be issued. No other instruction must be issued while the device is in Deep Power-down mode.

The Deep Power-down mode automatically stops at power-down, and the device always powers up in the Standby Power mode.

The Deep Power-down (DP) instruction is entered by driving Chip Select (\bar{S}) Low, followed by the instruction code on Serial Data input (DQ0). Chip Select (\bar{S}) must be driven Low for the entire duration of the sequence.

The instruction sequence is shown in [Figure 42](#).

Chip Select (\bar{S}) must be driven High after the eighth bit of the instruction code has been latched in, otherwise the Deep Power-down (DP) instruction is not executed. As soon as Chip Select (\bar{S}) is driven High, it requires a delay of t_{DP} before the supply current is reduced to I_{CC2} and the Deep Power-down mode is entered.

Any Deep Power-down (DP) instruction, while an Erase, Program or Write cycle is in progress, is rejected without having any effects on the cycle that is in progress.

Figure 42. Deep Power-down instruction sequence

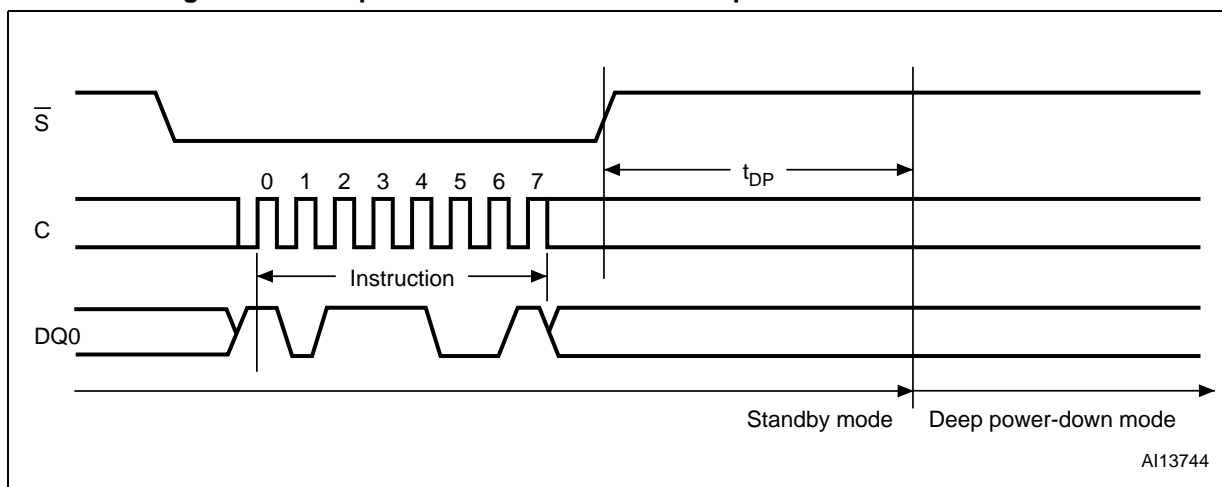

9.1.35 Release from Deep Power-down (RDP)

Once the device has entered the Deep Power-down mode, all instructions are ignored except the Release from Deep Power-down (RDP) instruction. Executing this instruction takes the device out of the Deep Power-down mode.

The Release from Deep Power-down (RDP) instruction is entered by driving Chip Select (\bar{S}) Low, followed by the instruction code on Serial Data input (DQ0). Chip Select (\bar{S}) must be driven Low for the entire duration of the sequence.

The instruction sequence is shown in [Figure 43](#).

The Release from Deep Power-down (RDP) instruction is terminated by driving Chip Select (\bar{S}) High. Sending additional clock cycles on Serial Clock (C), while Chip Select (\bar{S}) is driven Low, cause the instruction to be rejected, and not executed.

After Chip Select (\bar{S}) has been driven High, followed by a delay, t_{RDP} , the device is put in the Standby mode. Chip Select (\bar{S}) must remain High at least until this period is over. The device waits to be selected, so that it can receive, decode and execute instructions.

Any Release from Deep Power-down (RDP) instruction, while an Erase, Program or Write cycle is in progress, is rejected without having any effects on the cycle that is in progress.

Figure 43. Release from Deep Power-down instruction sequence

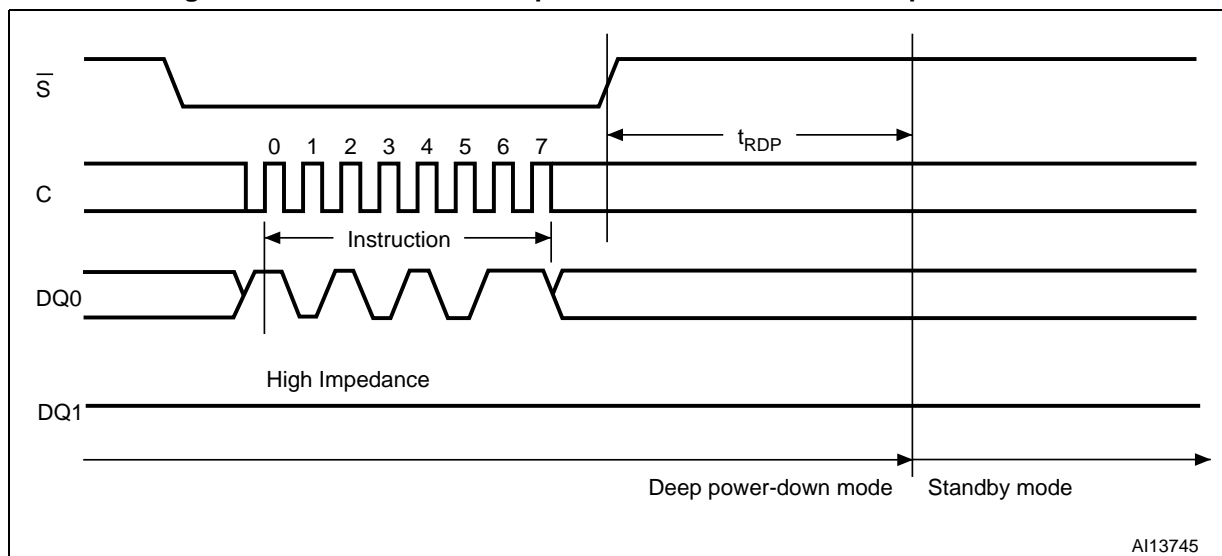

9.2 DIO-SPI Instructions

In DIO-SPI protocol, instructions, addresses and input/Output data always run in parallel on two wires: DQ0 and DQ1.

In the case of a Dual Command Fast Read (DCFR), Read OTP (ROTP), Read Lock Registers (RDLR), Read Status Register (RDSR), Read Flag Status Register (RFSR), Read NV Configuration Register (RDNVCR), Read Volatile Configuration Register (RDVCR), Read Volatile Enhanced Configuration Register (RDVECR) and Read Identification (RDID) instruction, the shifted-in instruction sequence is followed by a data-out sequence. Chip Select (\bar{S}) can be driven High after any bit of the data-out sequence is being shifted out.

In the case of a Dual Command Page Program (DCPP), Program OTP (POTP), Subsector Erase (SSE), Sector Erase (SE), Bulk Erase (BE), Program/Erase Suspend (PES), Program/Erase Resume (PER), Write Status Register (WRSR), Clear Flag Status Register (CLFSR), Write to Lock Register (WRLR), Write Configuration Register (WRVCR), Write Enhanced Configuration Register (WRVECR), Write NV Configuration Register (WRNVCR), Write Enable (WREN) or Write Disable (WRDI) instruction, Chip Select (\bar{S}) must be driven High exactly at a byte boundary, otherwise the instruction is rejected, and is not executed.

All attempts to access the memory array during a Write Status Register cycle, a Write Non Volatile Configuration Register, a Program cycle or an Erase cycle are ignored, and the internal Write Status Register cycle, Write Non Volatile Configuration Register, Program cycle or Erase cycle continues unaffected, the only exception is the Program/Erase Suspend instruction (PES), that can be used to pause all the program and the erase cycles but the Program OTP (POT), Bulk Erase (BE) and Write Non Volatile Configuration Register. The suspended program or erase cycle can be resumed by mean of the Program/Erase Resume instruction (PER). During the program/erase cycles also the polling instructions (to check if the internal modify cycle is finished by mean of the WIP bit of the Status Register or of the Program/Erase controller bit of the Flag Status register) are also accepted to allow the application checking the end of the internal modify cycles, of course these polling instructions don't affect the internal cycles performing.

Table 23. Instruction set: DIO-SPI protocol

Instruction	Description	One-byte Instruction Code (BIN)	One-byte Instruction Code (HEX)	Address bytes	Dummy clock cycle	Data bytes
MIORDID	Multiple I/O read identification	1010 1111	AFh	0	0	1 to 3
DCFR	Dual Command Fast Read	0000 1011	0Bh	3	8 ⁽¹⁾	1 to ∞
		0011 1011	3Bh	3	8 ⁽¹⁾	1 to ∞
		1011 1011	BBh	3	8 ⁽¹⁾	1 to ∞
ROTP	Read OTP	0100 1011	4Bh	3	8 ⁽¹⁾	1 to 65
WREN	Write Enable	0000 0110	06h	0	0	0
WRDI	Write Disable	0000 0100	04h	0	0	0
DCPP	Dual Command Page Program	0000 0010	02h	3	0	1 to 256
		1010 0010	A2h	3	0	1 to 256
		1101 0010	D2h	3	0	1 to 256
POTP	Program OTP	0100 0010	42h	3	0	1 to 65
SSE ⁽²⁾	SubSector Erase	0010 0000	20h	3	0	0
SE	Sector Erase	1101 1000	D8h	3	0	0
BE	Bulk Erase	1100 0111	C7h	0	0	0
PER	Program/Erase Resume	0111 1010	7Ah	0	0	0
PES	Program/Erase Suspend	0111 0101	75h	0	0	0
RDSR	Read Status Register	0000 0101	05h	0	0	1 to ∞
WRSR	Write Status Register	0000 0001	01h	0	0	1
RDLR	Read Lock Register	1110 1000	E8h	3	0	1 to ∞
WRLR	Write to Lock Register	1110 0101	E5h	3	0	1
RFSR	Read Flag Status Register	0111 0000	70h	0	0	1 to ∞
CLFSR	Clear Flag Status Register	0101 0000	50h	0	0	0
RDNVCR	Read NV Configuration Register	1011 0101	B5h	0	0	2
WRNVCR	Write NV Configuration Register	1011 0001	B1h	0	0	2
RDVCR	Read Volatile Configuration Register	1000 0101	85h	0	0	1 to ∞
WRVCR	Write Volatile Configuration Register	1000 0001	81h	0	0	1
RDVECR	Read Volatile Enhanced Configuration Register	0110 0101	65h	0	0	1 to ∞
WRVECR	Write Volatile Enhanced Configuration Register	0110 0001	61h	0	0	1
DP	Deep Power-down	1011 1001	B9h	0	0	0
RDP	Release from Deep Power-down	1010 1011	ABh	0	0	0

- 1) The number of Dummy Clock cycles is configurable by the user
- 2) SSE is only available in devices with Bottom or Top architecture.

9.2.1 Multiple I/O Read Identification protocol

The Multiple Input/Output Read Identification (MIORDID) instruction allows to read the device identification data in the DIO-SPI protocol:

- Manufacturer identification (1 byte)
- Device identification (2 bytes)

Unlike the RDID instruction of the Extended SPI protocol, the Multiple Input/Output instruction can not read the Unique ID code (UID) (17 bytes).

For further details on the manufacturer and device identification codes please refer to [Section 9.1.1: Read Identification \(RDID\)](#).

Any Multiple Input/Output Read Identification (MIORDID) instruction while an Erase or Program cycle is in progress, is not decoded, and has no effect on the cycle that is in progress.

The device is first selected by driving Chip Select (\bar{S}) Low. Then, the 8-bit instruction code for the instruction is shifted in parallel on the 2 pins DQ0 and DQ1. After this, the 24-bit device identification, stored in the memory, will be shifted out on again in parallel on DQ1 and DQ0. Each two bits are shifted out during the falling edge of Serial Clock (C).

The Read Identification (RDID) instruction is terminated by driving Chip Select (\bar{S}) High at any time during data output.

When Chip Select (\bar{S}) is driven High, the device is put in the Standby Power mode. Once in the Standby Power mode, the device waits to be selected, so that it can receive, decode and execute instructions.

Figure 44. Multiple I/O Read Identification instruction and data-out sequence DIO-SPI

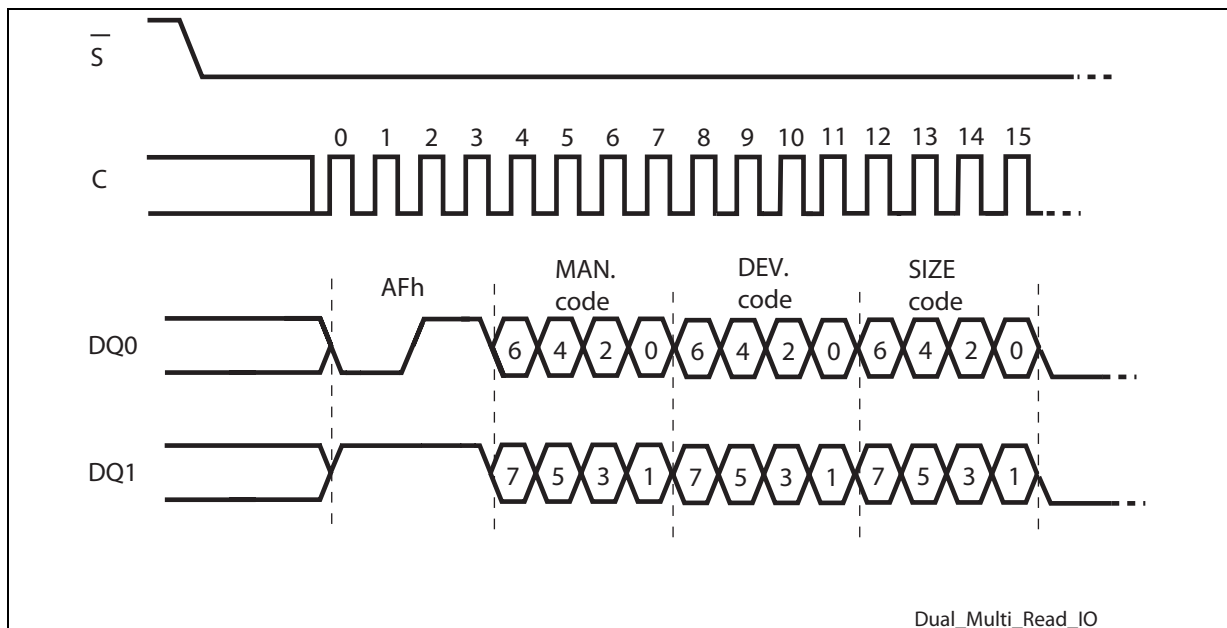

9.2.2 Dual Command Fast Read (DCFR)

The Dual Command Fast Read (DCFR) instruction allows to read the memory in DIO-SPI protocol, parallelizing the instruction code, the address and the output data on two pins (DQ0 and DQ1). The Dual Command Fast Read (DCFR) instruction can be issued, when the device is set in DIO-SPI mode, by sending to the memory indifferently one of the 3 instructions codes: 0Bh, 3Bh or BBh, the effect is exactly the same. The 3 instruction codes are all accepted to help the application code porting from Extended SPI protocol to DIO-SPI protocol.

Apart for the parallelizing on two pins of the instruction code, the Dual Command Fast Read instruction functionality is exactly the same as the Dual I/O Fast Read of the Extended SPI protocol, please refer to [Section 9.1.5: Dual I/O Fast Read](#) for further details.

Figure 45. Dual Command Fast Read instruction and data-out sequence DIO-SPI

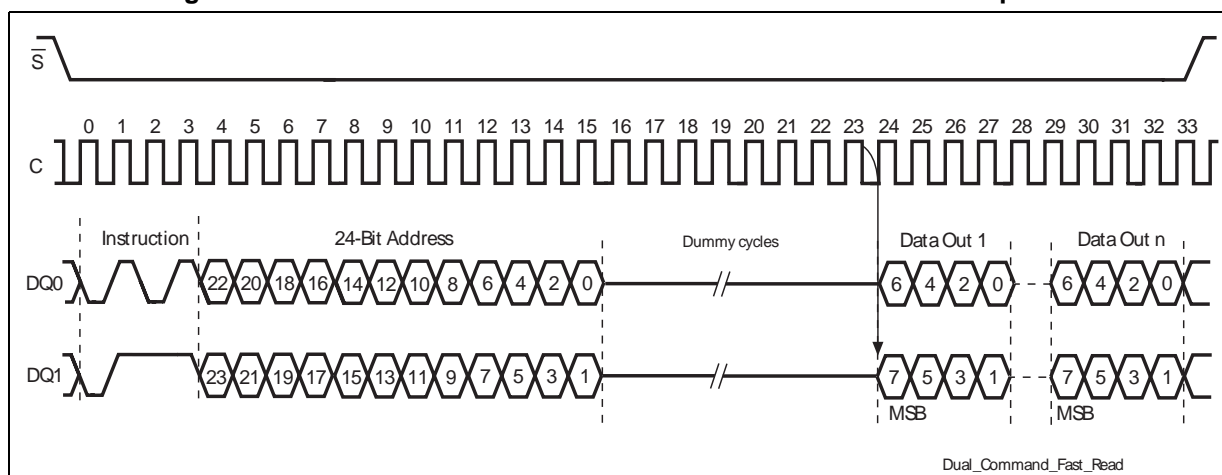

9.2.3 Read OTP (ROTP)

The Read OTP (ROTP) instruction is used to read the 64 bytes OTP area in the DIO-SPI protocol. The instruction functionality is exactly the same as the Read OTP instruction of the Extended SPI protocol; the only difference is that in the DIO-SPI protocol instruction code, address and output data are all parallelized on the two pins DQ0 and DQ1.

Note: The dummy bits can not be parallelized since these clock cycles are requested to perform the internal reading operation.

Figure 46. Read OTP instruction and data-out sequence DIO-SPI

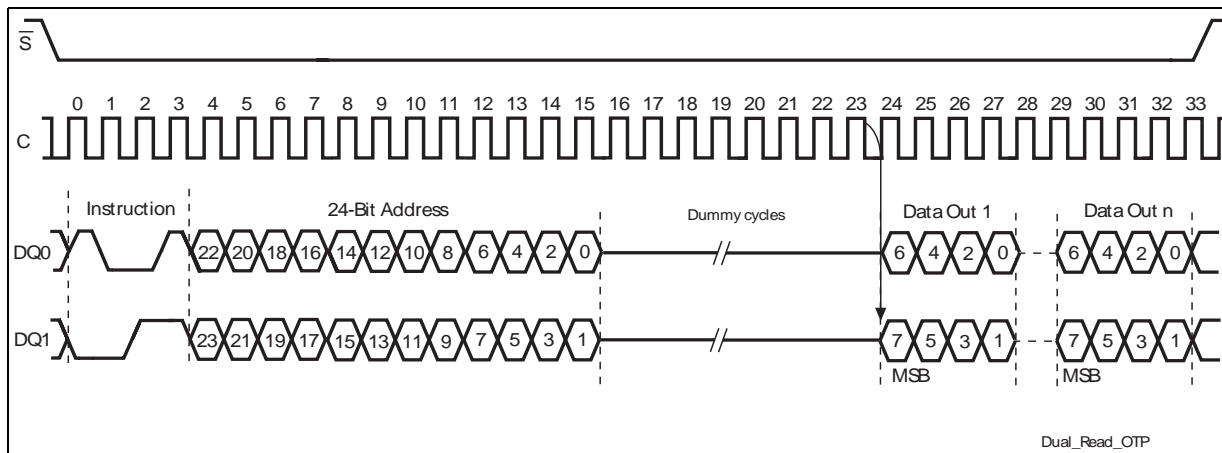

9.2.4 Write Enable (WREN)

The Write Enable (WREN) instruction sets the Write Enable Latch (WEL) bit.

Apart from the parallelizing of the instruction code on the two pins $DQ0$ and $DQ1$, the instruction functionality is exactly the same as the Write Enable (WREN) instruction of the Extended SPI protocol.

Figure 47. Write Enable instruction sequence DIO-SPI

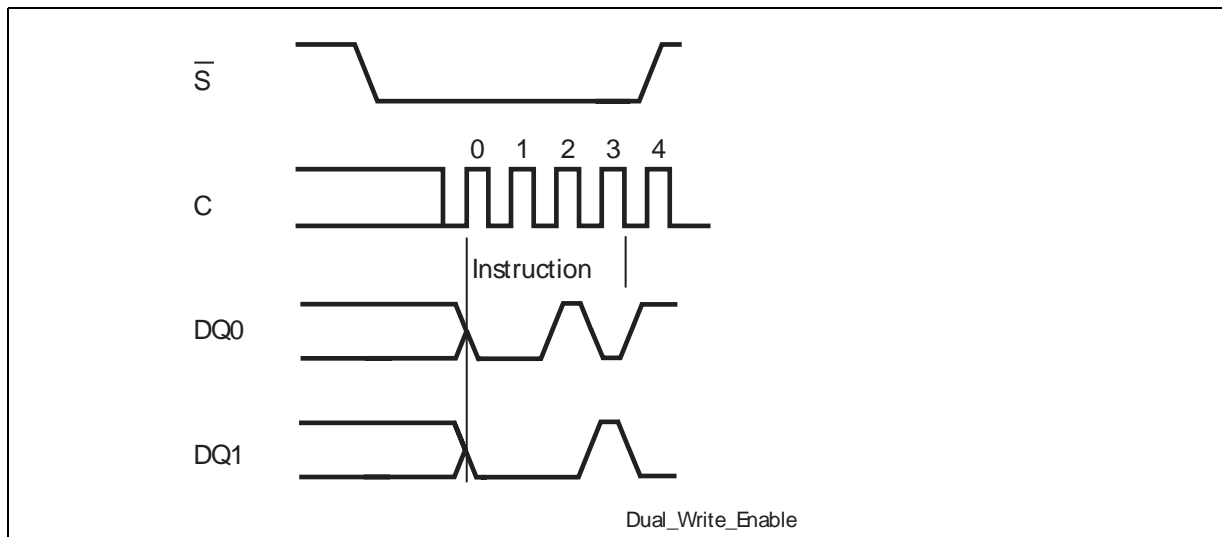

9.2.5 Write Disable (WRDI)

The Write Disable (WRDI) instruction resets the Write Enable Latch (WEL) bit.

Apart from the parallelizing of the instruction code on the two pins $DQ0$ and $DQ1$, the instruction functionality is exactly the same as the Write Disable (WRDI) instruction of the Extended SPI protocol, please refer to [Section 9.1.10: Write Disable \(WRDI\)](#) for further details.

Figure 48. Write Disable instruction sequence DIO-SPI

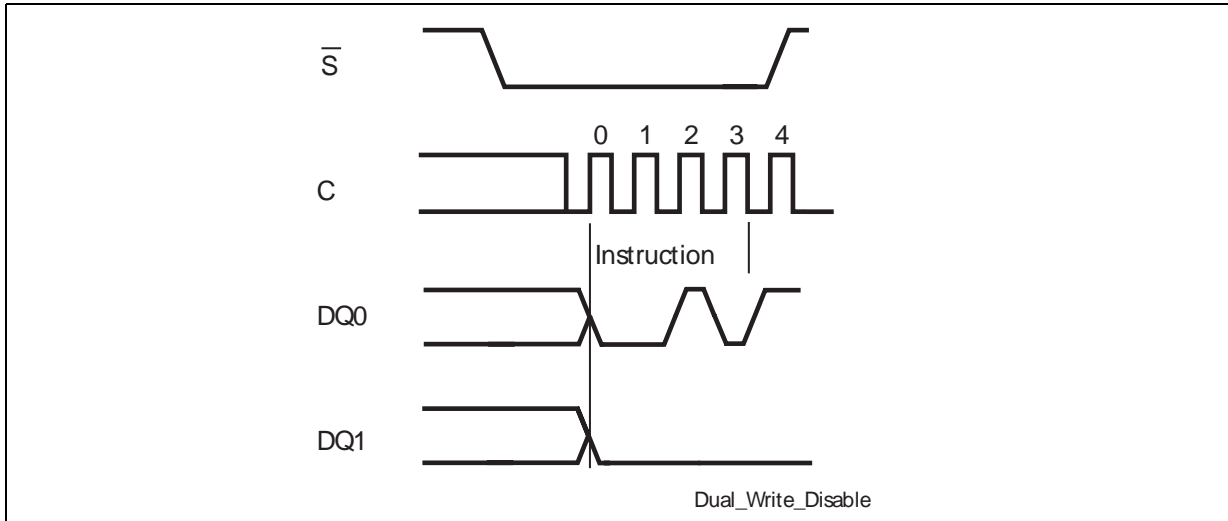

9.2.6 Dual Command Page Program (DCPP)

The Dual Command Page Program (DCPP) instruction allows to program the memory content in DIO-SPI protocol, parallelizing the instruction code, the address and the input data on two pins (DQ0 and DQ1). Before it can be accepted, a Write Enable (WREN) instruction must previously have been executed. The Dual Command Page Program (DCPP) instruction can be issued, when the device is set in DIO-SPI mode, by sending to the memory indifferently one of the 3 instructions codes: 02h, A2h or D2h, the effect is exactly the same. The 3 instruction codes are all accepted to help the application code porting from Extended SPI protocol to DIO-SPI protocol.

Apart for the parallelizing on two pins of the instruction code, the Dual Command Page Program instruction functionality is exactly the same as the Dual Input Extended Fast Program of the Extended SPI protocol, please refer to [Section 9.1.13: Dual Input Extended Fast Program](#) for further details.

Figure 49. Dual Command Page Program instruction sequence DSP, 02h

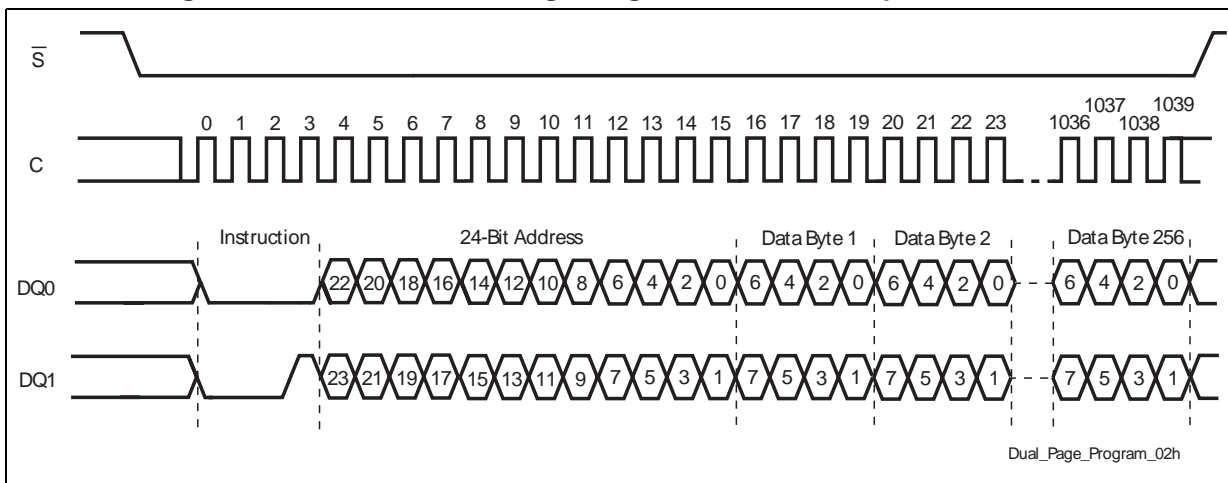

Figure 50. Dual Command Page Program instruction sequence DSP, A2h

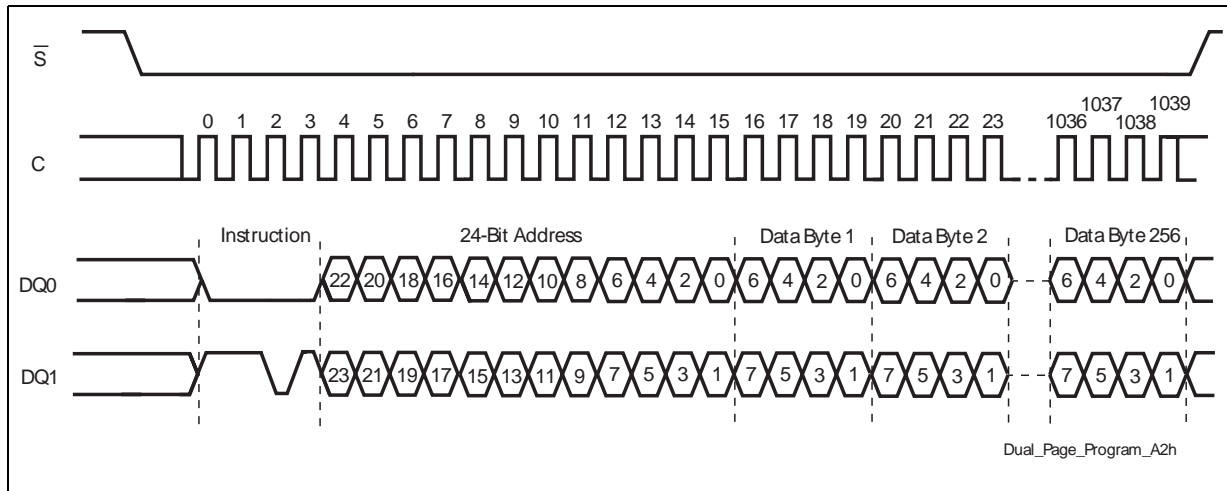
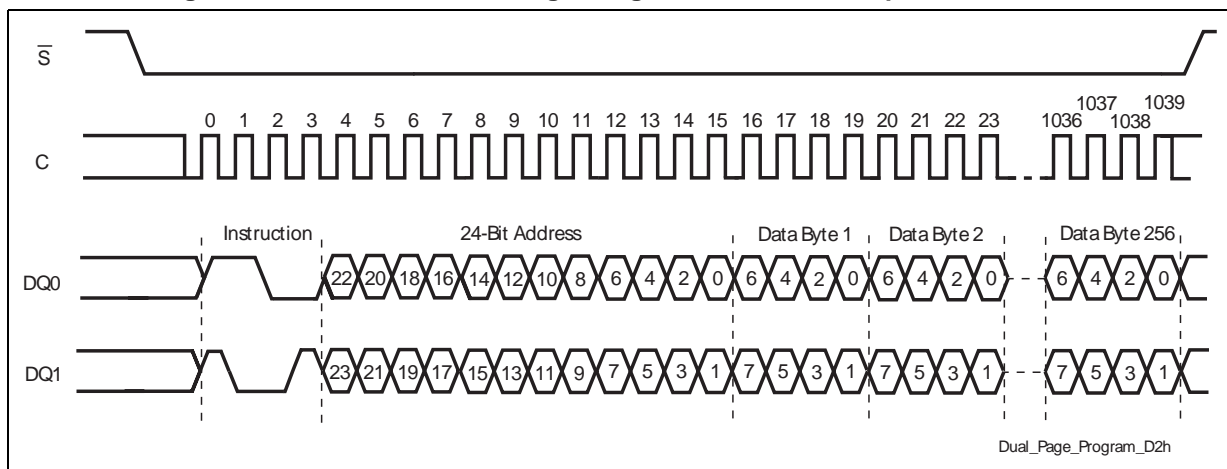

Figure 51. Dual Command Page Program instruction sequence DSP, D2h



9.2.7 Program OTP instruction (POTP)

The Program OTP instruction (POTP) is used to program at most 64 bytes to the OTP memory area (by changing bits from 1 to 0, only). Before it can be accepted, a Write Enable (WREN) instruction must previously have been executed.

Apart from the parallelizing of the instruction code, address and input data on the two pins DQ0 and DQ1, the instruction functionality (as well as the locking OTP method) is exactly the same as the Program OTP (POTP) instruction of the Extended SPI protocol, please refer to [Section 9.1.16: Program OTP instruction \(POTP\)](#) for further details.

Figure 52. Program OTP instruction sequence DIO-SPI

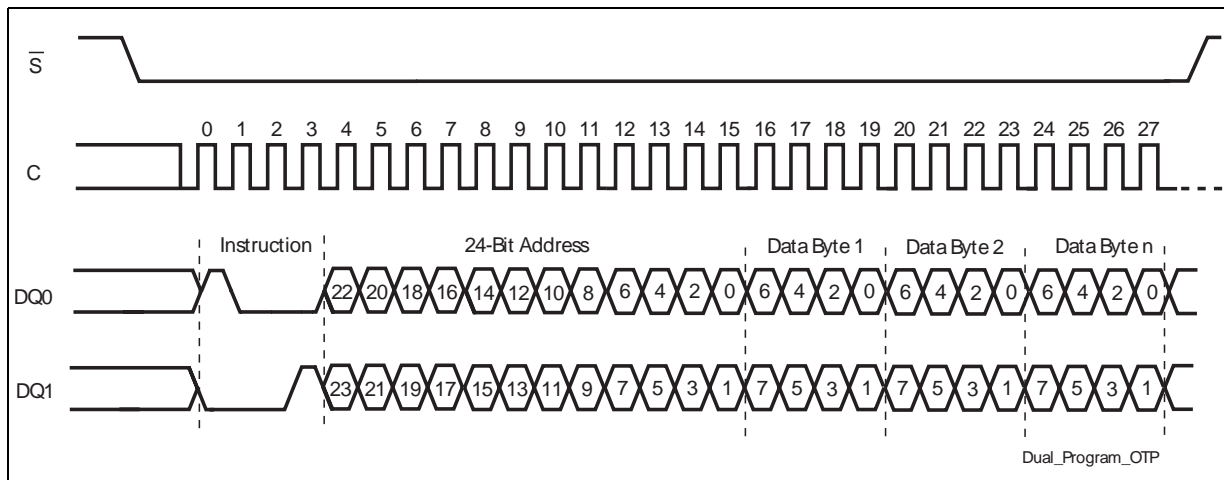

9.2.8 Subsector Erase (SSE)

For devices with bottom or top architecture, at the bottom (or top) of the addressable area there are 8 boot sectors, each one having 16 4Kbytes subsectors. The Subsector Erase (SSE) instruction sets to '1' (FFh) all bits inside the chosen subsector. Before it can be accepted, a Write Enable (WREN) instruction must previously have been executed.

Apart from the parallelizing of the instruction code and the address on the two pins DQ0 and DQ1, the instruction functionality is exactly the same as the Subsector Erase (SSE) instruction of the Extended SPI protocol, please refer to [Section 9.1.17: Subsector Erase \(SSE\)](#) for further details.

Figure 53. Subsector Erase instruction sequence DIO-SPI

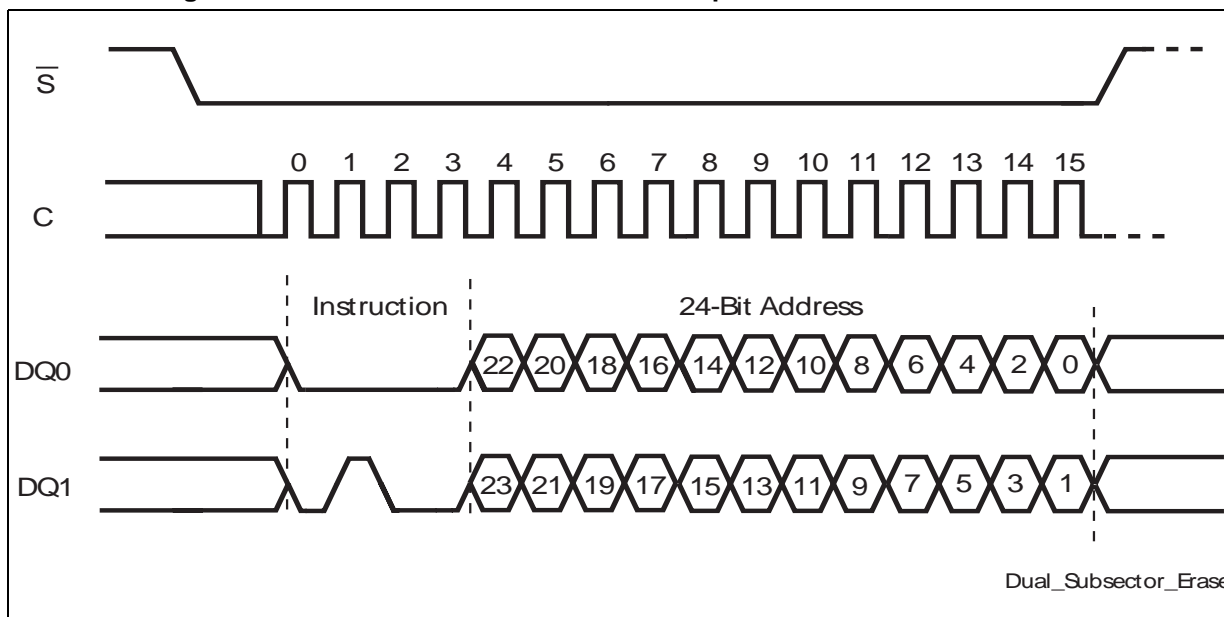

9.2.9 Sector Erase (SE)

The Sector Erase (SE) instruction sets to '1' (FFh) all bits inside the chosen sector. Before it can be accepted, a Write Enable (WREN) instruction must previously have been executed.

Apart from the parallelizing of the instruction code and the address on the two pins DQ0 and DQ1, the instruction functionality is exactly the same as the Sector Erase (SE) instruction of the Extended SPI protocol, please refer to [Section 9.1.18: Sector Erase \(SE\)](#) for further details.

Figure 54. Sector Erase instruction sequence DIO-SPI

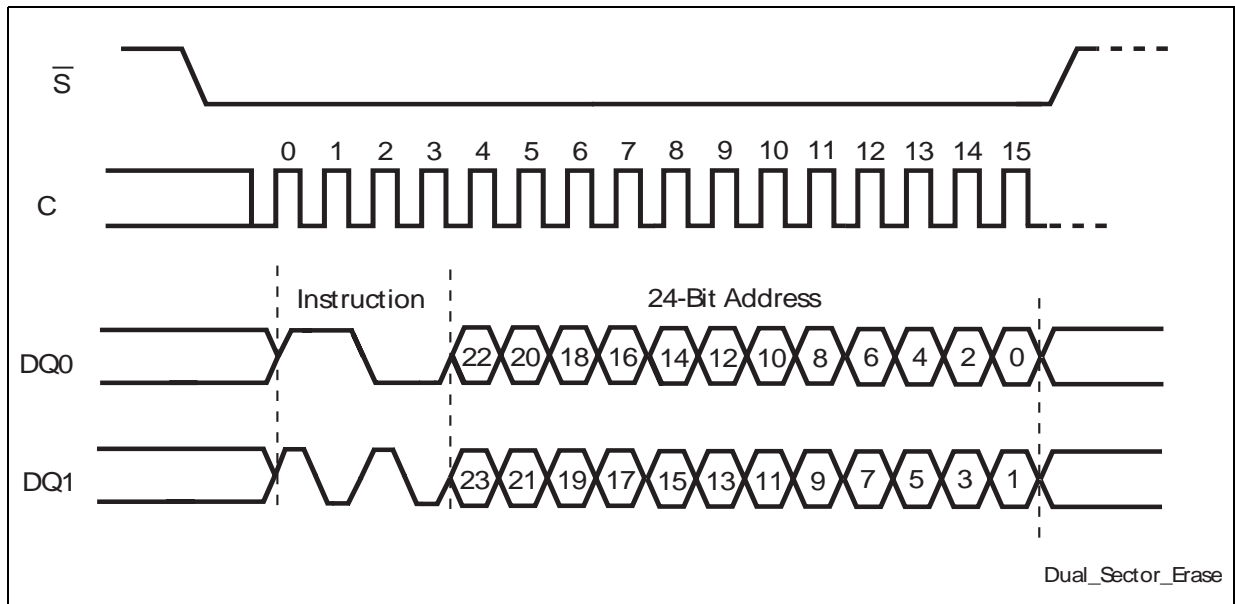

9.2.10 Bulk Erase (BE)

The Bulk Erase (BE) instruction sets all bits to '1' (FFh). Before it can be accepted, a Write Enable (WREN) instruction must previously have been executed.

Apart from the parallelizing of the instruction code on the two pins DQ0 and DQ1, the instruction functionality is exactly the same as the Bulk Erase (BE) instruction of the Extended SPI protocol, please refer to [Section 9.1.19: Bulk Erase \(BE\)](#) for further details.

Figure 55. Bulk Erase instruction sequence DIO-SPI

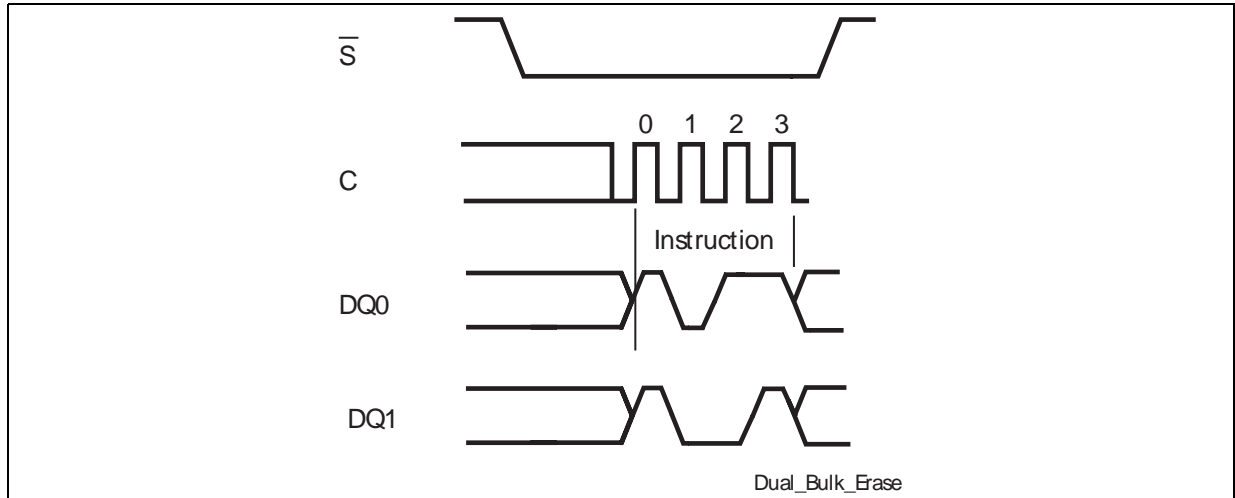

9.2.11 Program/Erase Suspend

The Program/Erase Suspend instruction allows the controller to interrupt a Program or an Erase instruction, in particular: Sector Erase and Dual Command Page Program can be suspended and erased while Subsector Erase, Bulk Erase, Write Non Volatile Configuration register, and Program OTP cannot be suspended.

Apart from the parallelizing of the instruction code on the two pins DQ0 and DQ1, the instruction functionality is exactly the same as the Program/Erase Suspend (PES) instruction of the Extended SPI protocol.

Figure 56. Program/Erase Suspend instruction sequence DIO-SPI

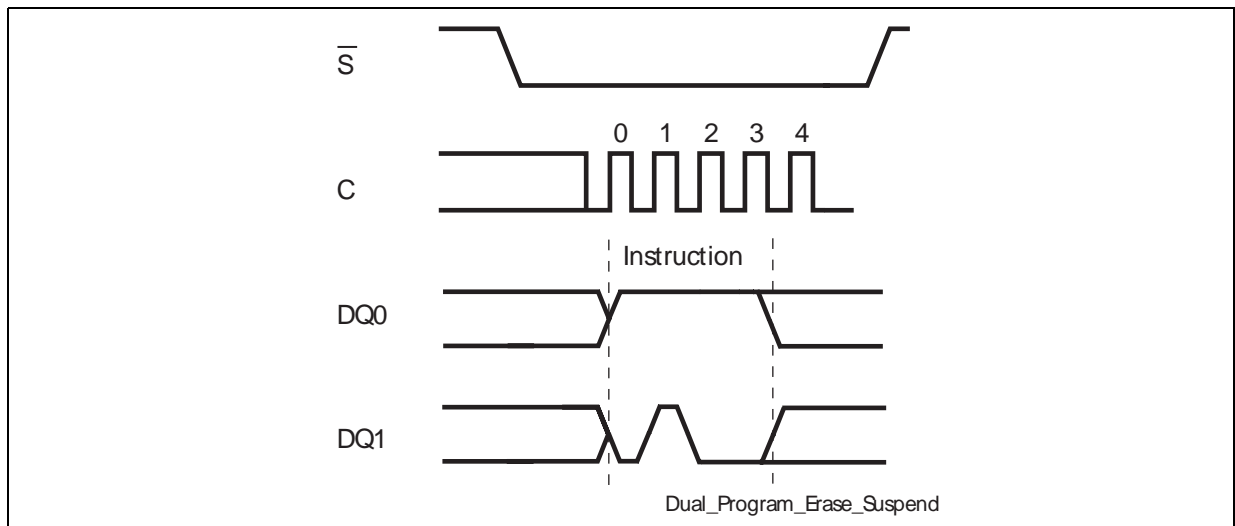

9.2.12 Program/Erase Resume

After a Program/Erase suspend instruction, a Program/Erase Resume instruction is required to continue performing the suspended Program or Erase sequence.

Apart from the parallelizing of the instruction code on the two pins DQ0 and DQ1, the instruction functionality is exactly the same as the Program/Erase Resume (PER)

instruction of the Extended SPI protocol, please refer to [Section 9.1.21: Program/Erase Resume](#) for further details.

Figure 57. Program/Erase Resume instruction sequence DIO-SPI

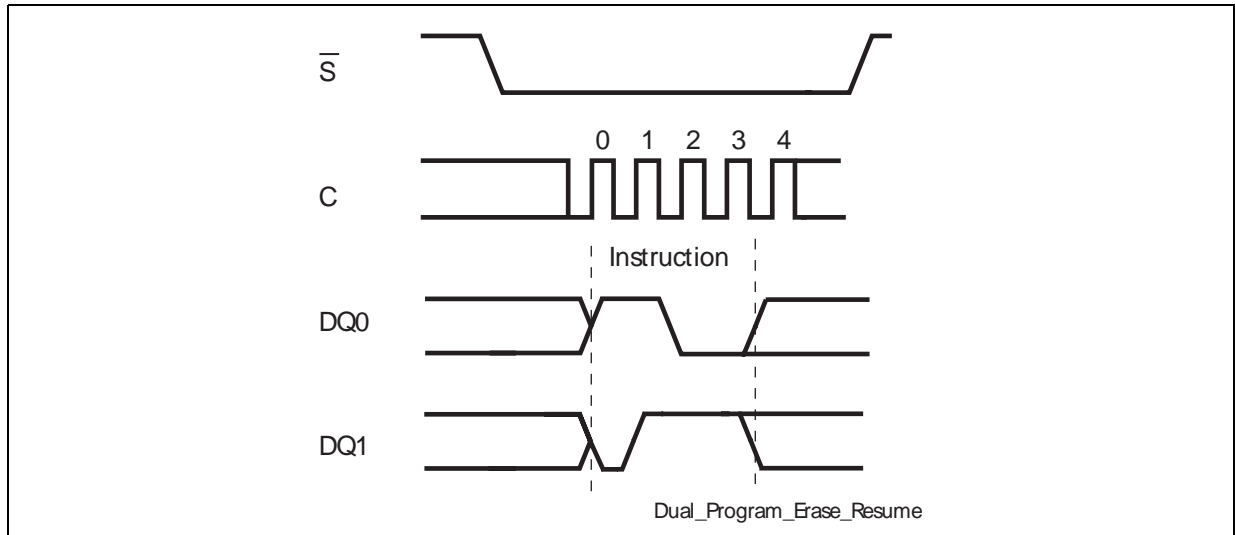

9.2.13 Read Status Register (RDSR)

The Read Status Register (RDSR) instruction allows the Status Register to be read. Apart from the parallelizing of the instruction code and the output data on the two pins DQ0 and DQ1, the instruction functionality is exactly the same as the Read Status Register (RDSR) instruction of the Extended SPI protocol, please refer to [Section 9.1.22: Read Status Register \(RDSR\)](#) for further details.

Figure 58. Read Status Register instruction sequence DIO-SPI

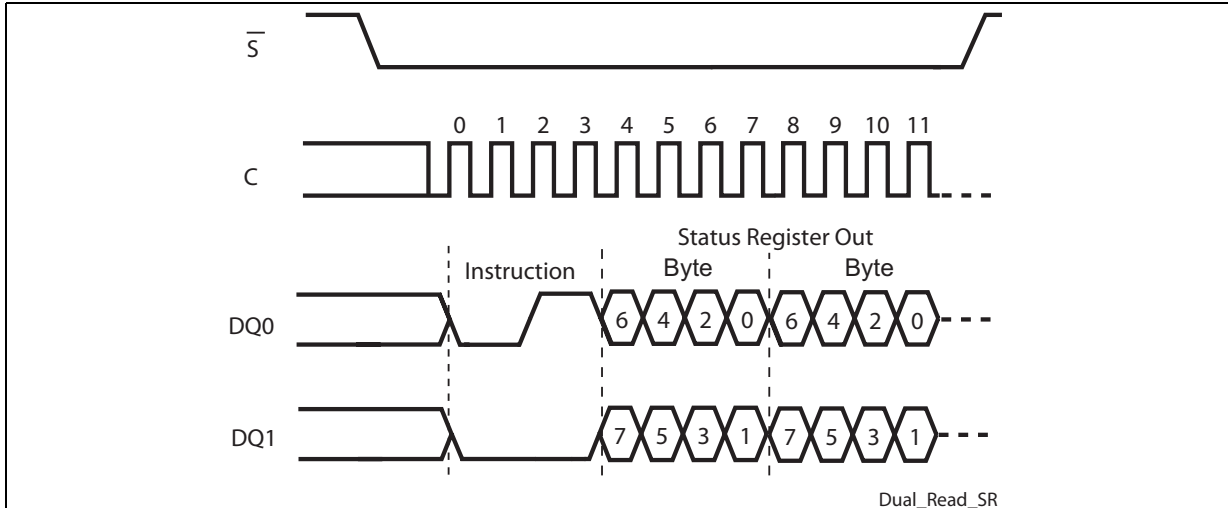

9.2.14 Write status register (WRSR)

The write status register (WRSR) instruction allows new values to be written to the status register. Before it can be accepted, a write enable (WREN) instruction must previously have been executed. Apart from the parallelizing of the instruction code and the input data on the two pins DQ0 and DQ1, the instruction functionality and the protection feature management is exactly the same as the Write Status Register (WRSR) instruction of the Extended SPI protocol, please refer to [Section 9.1.23: Write status register \(WRSR\)](#) for further details.

Figure 59. Write Status Register instruction sequence DIO-SPI

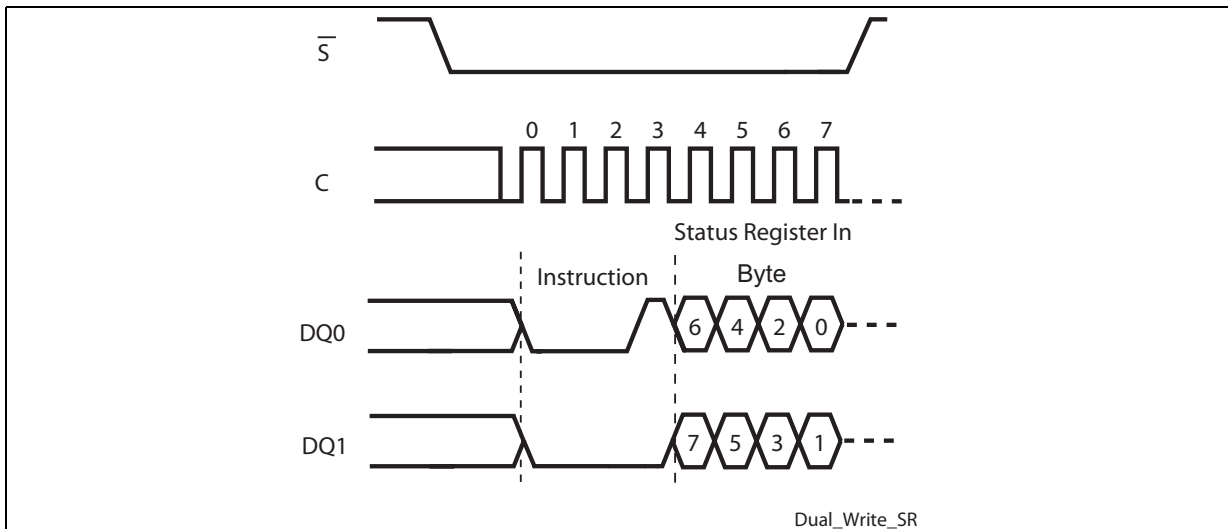

9.2.15 Read Lock Register (RDLR)

The Read Lock Register instructions is used to read the lock register content.

Apart from the parallelizing of the instruction code, the address and the output data on the two pins DQ0 and DQ1, the instruction functionality is exactly the same as the Read Lock Register (RDLR) instruction of the Extended SPI protocol, please refer to [Section 9.1.24: Read Lock Register \(RDLR\)](#) for further details.

Figure 60. Read Lock Register instruction and data-out sequence DIO-SPI

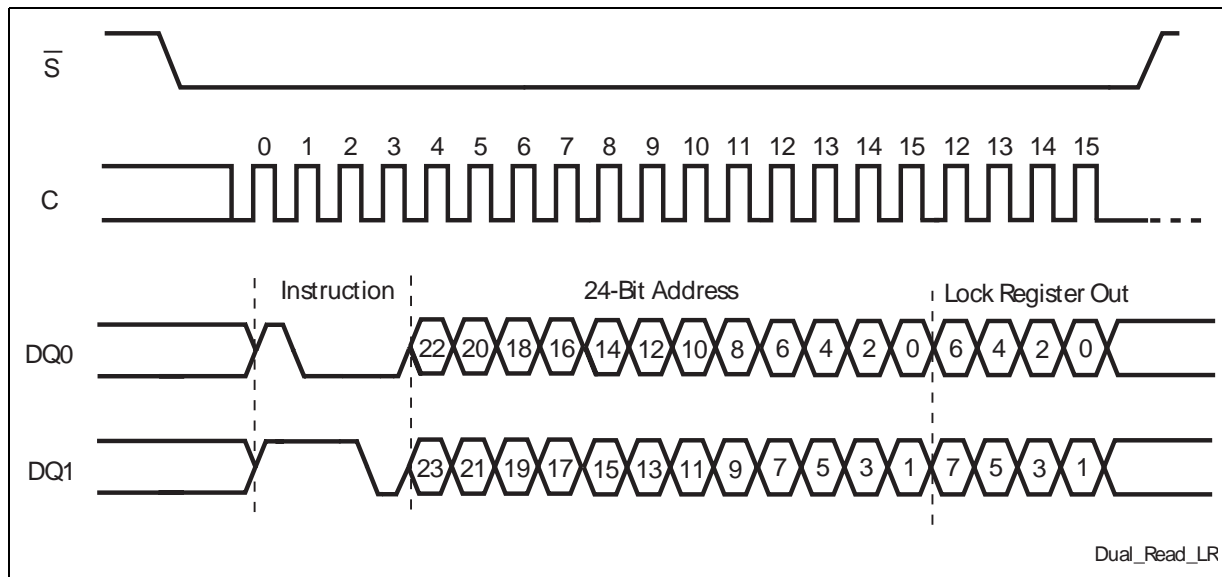

9.2.16 Write to Lock Register (WRLR)

The Write to Lock Register (WRLR) instruction allows bits to be changed in the Lock Registers. Before it can be accepted, a Write Enable (WREN) instruction must previously have been executed.

Apart from the parallelizing of the instruction code, the address and the input data on the two pins DQ0 and DQ1, the instruction functionality is exactly the same as the Write to Lock Register (WRLR) instruction of the Extended SPI protocol, please refer to [Section 9.1.25: Write to Lock Register \(WRLR\)](#) for further details.

Figure 61. Write to Lock Register instruction sequence DIO-SPI

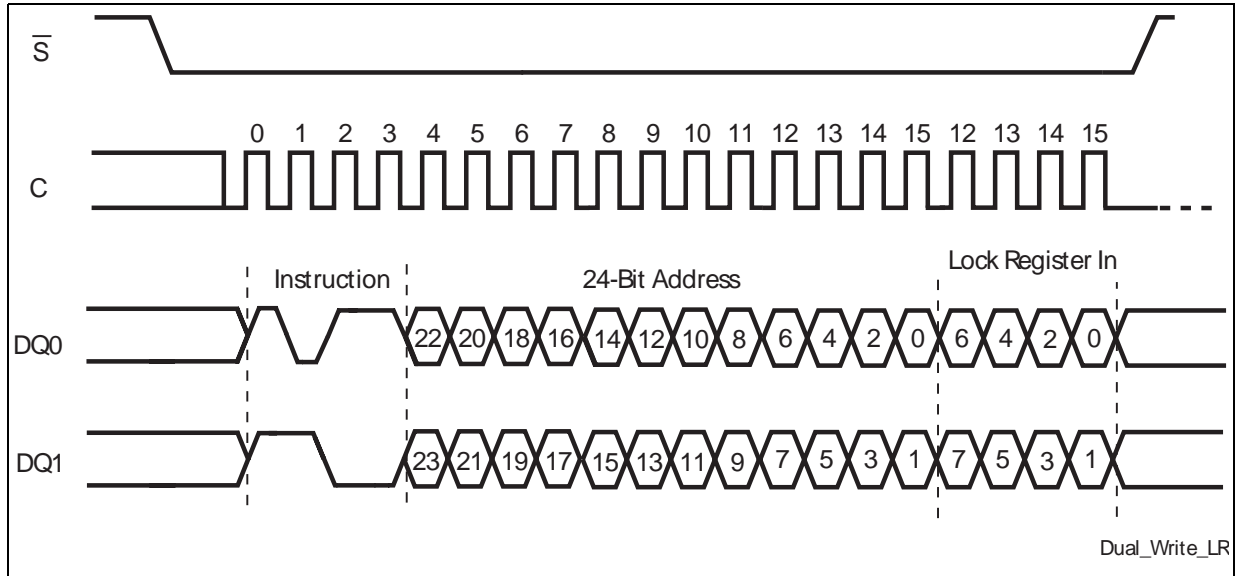

9.2.17 Read Flag Status Register

The Read Flag Status Register (RFSR) instruction allows the Flag Status Register to be read.

Apart from the parallelizing of the instruction code and the output data on the two pins $DQ0$ and $DQ1$, the instruction functionality is exactly the same as the Read Flag Status Register (RFSR) instruction of the Extended SPI protocol, please refer to [Section 9.1.26: Read Flag Status Register](#) for further details.

Figure 62. Read Flag Status Register instruction sequence DIO-SPI

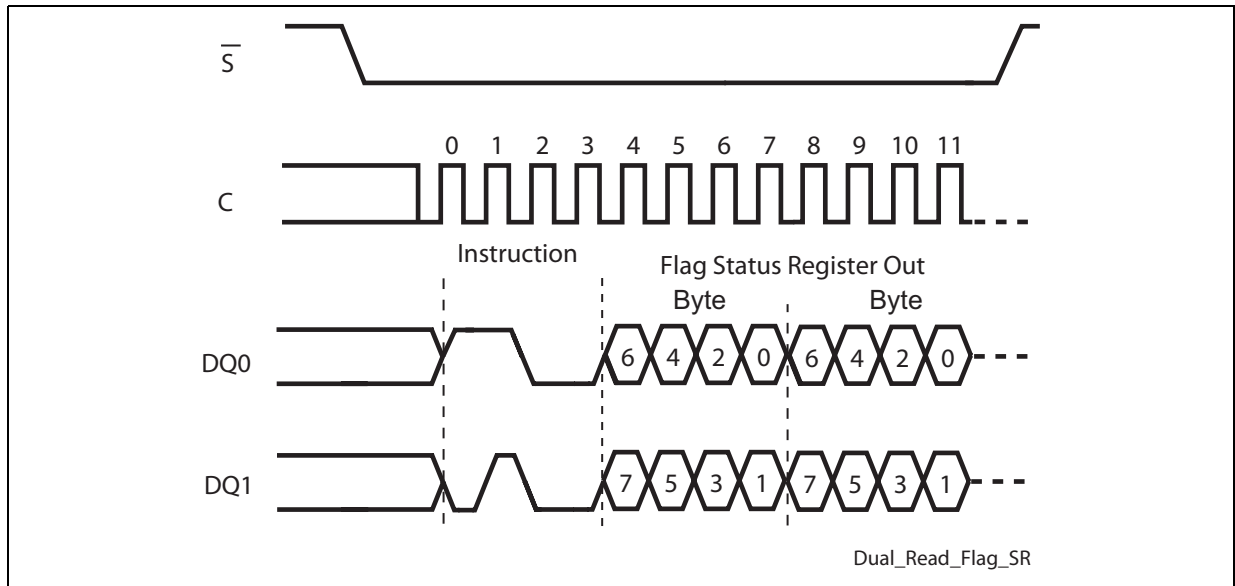

9.2.18 Clear Flag Status Register

The Clear Flag Status Register (CLFSR) instruction reset the error Flag Status Register bits (Erase Error bit, Program Error bit, VPP Error bit, Protection Error bit). It is not necessary to set the WEL bit before the Clear Flag Status Register instruction is executed. The WEL bit will be unchanged after this command is executed.

Figure 63. Clear Flag Status Register instruction sequence DIO-SPI

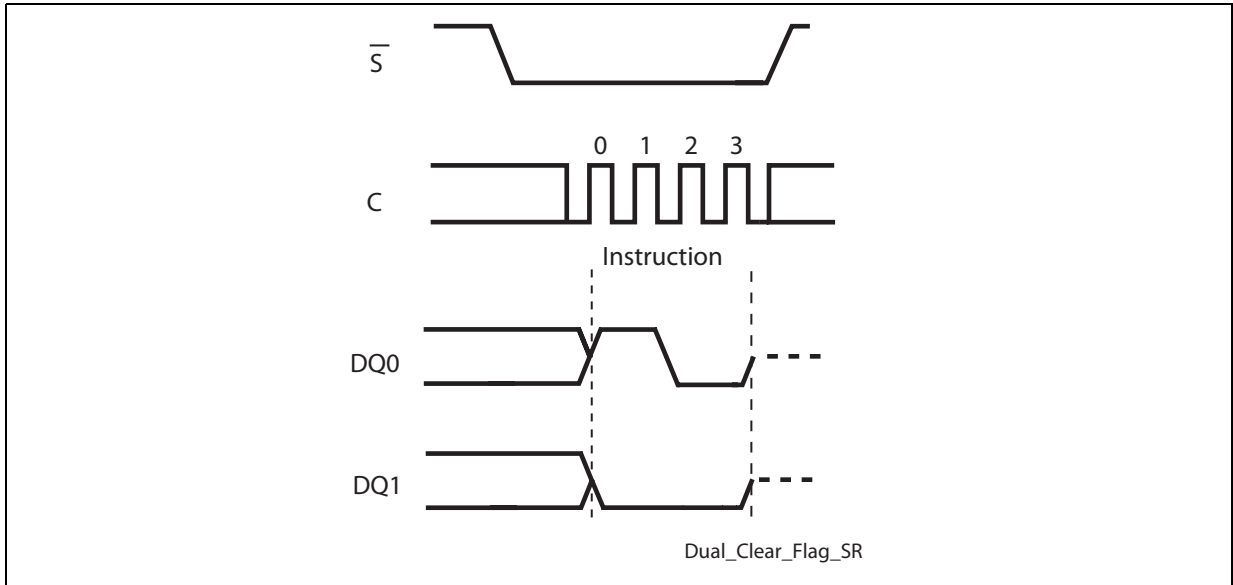

9.2.19 Read NV Configuration Register

The Read Non Volatile Configuration Register (RDNVCR) instruction allows the Non Volatile Configuration Register to be read.

Figure 64. Read NV Configuration Register instruction sequence DIO-SPI

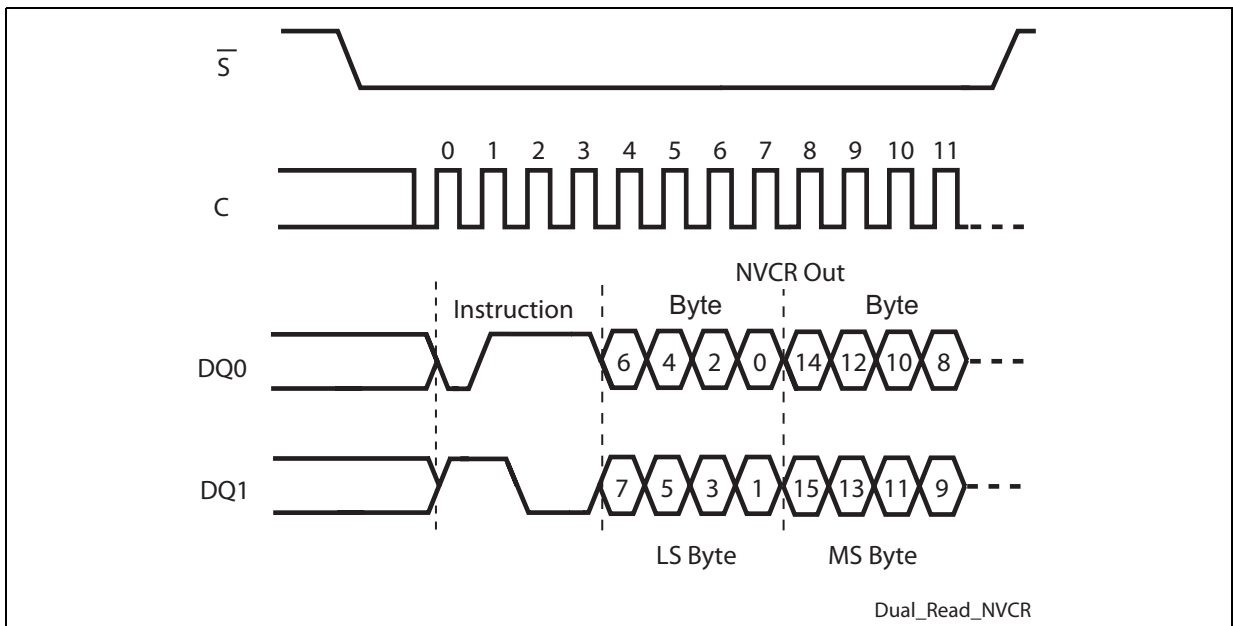

9.2.20 Write NV Configuration Register

The Write Non Volatile Configuration register (WRNVCR) instruction allows new values to be written to the Non Volatile Configuration register. Before it can be accepted, a write enable (WREN) instruction must previously have been executed.

Apart from the parallelizing of the instruction code and the input data on the two pins DQ0 and DQ1, the instruction functionality is exactly the same as the Write Non Volatile Configuration Register (WNVCR) instruction of the Extended SPI protocol, please refer to [Section 9.1.29: Write NV Configuration Register](#) for further details.

Figure 65. Write NV Configuration Register instruction sequence DIO-SPI

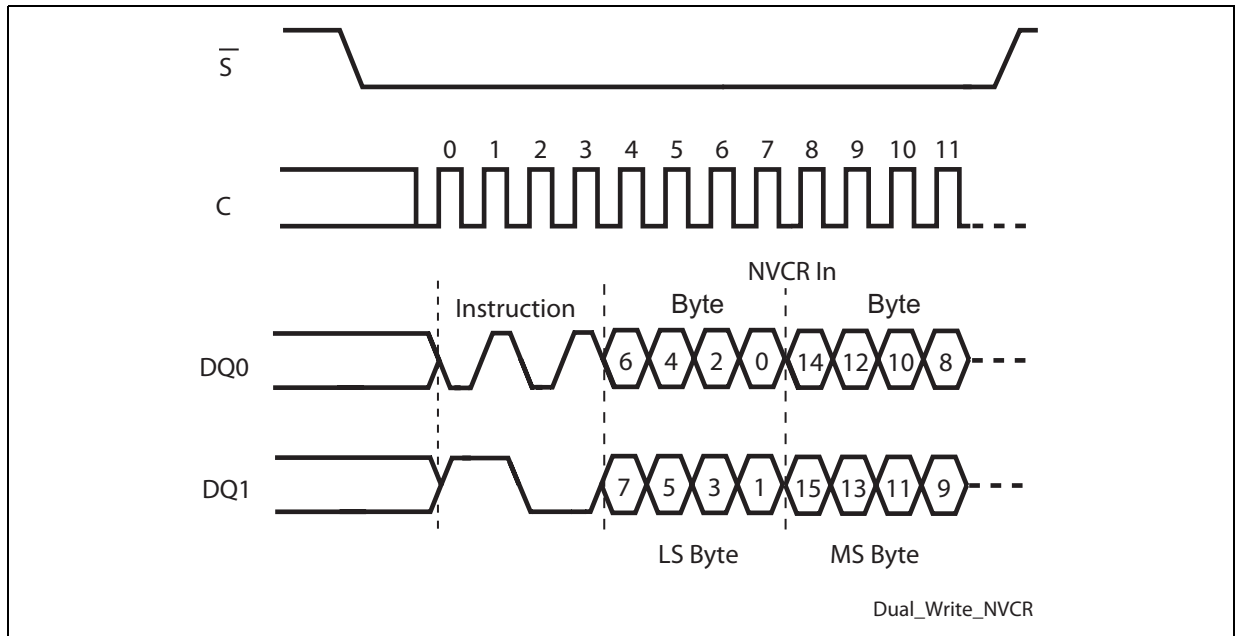

9.2.21 Read Volatile Configuration Register

The Read Volatile Configuration Register (RDVCR) instruction allows the Volatile Configuration Register to be read. See [Table 6.: Volatile Configuration Register](#).

Figure 66. Read Volatile Configuration Register instruction sequence DIO-SPI

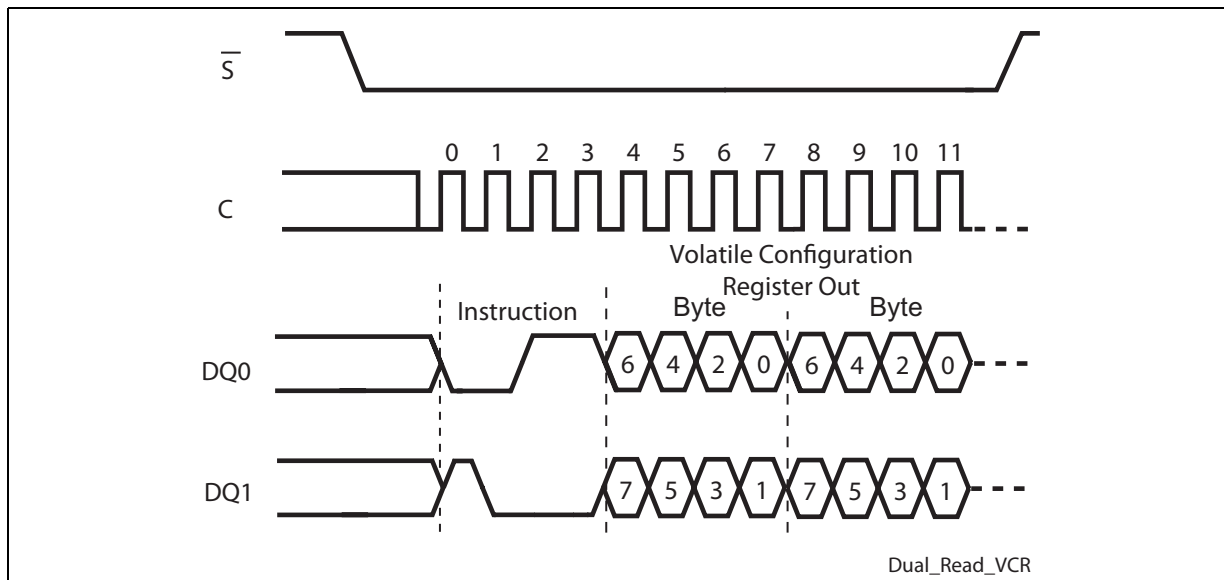

9.2.22 Write Volatile Configuration Register

The Write Volatile Configuration register (WRVCR) instruction allows new values to be written to the Volatile Configuration register. Before it can be accepted, a write enable (WREN) instruction must have been executed previously. In case of Fast POR, the WREN instruction is not required because a WREN instruction gets the device out from the Fast POR state (See [Section 11.1: Fast POR](#)).

Apart from the parallelizing of the instruction code and the input data on the two pins DQ0 and DQ1, the instruction functionality is exactly the same as the Write Volatile Configuration Register (WVCR) instruction of the Extended SPI protocol, please refer to [Section 9.1.31: Write Volatile Configuration Register](#) for further details.

Figure 67. Write Volatile Configuration Register instruction sequence DIO-SPI

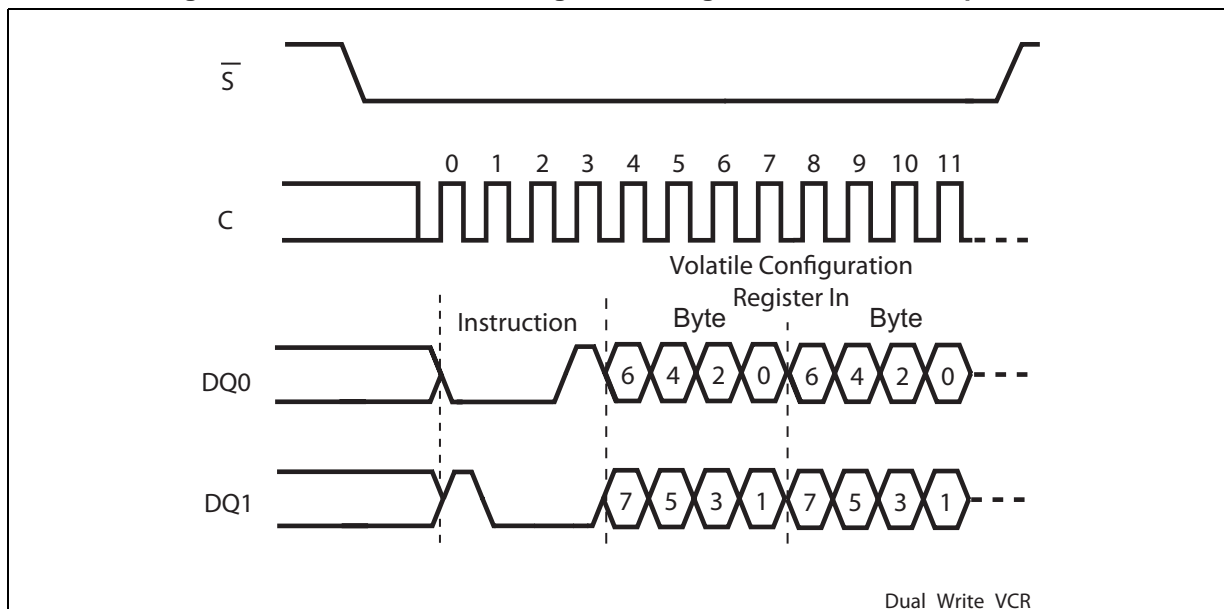

9.2.23 Read Volatile Enhanced Configuration Register

The Read Volatile Enhanced Configuration Register (RDVECR) instruction allows the Volatile Configuration Register to be read.

Figure 68. Read Volatile Enhanced Configuration Register instruction sequence DIO-SPI

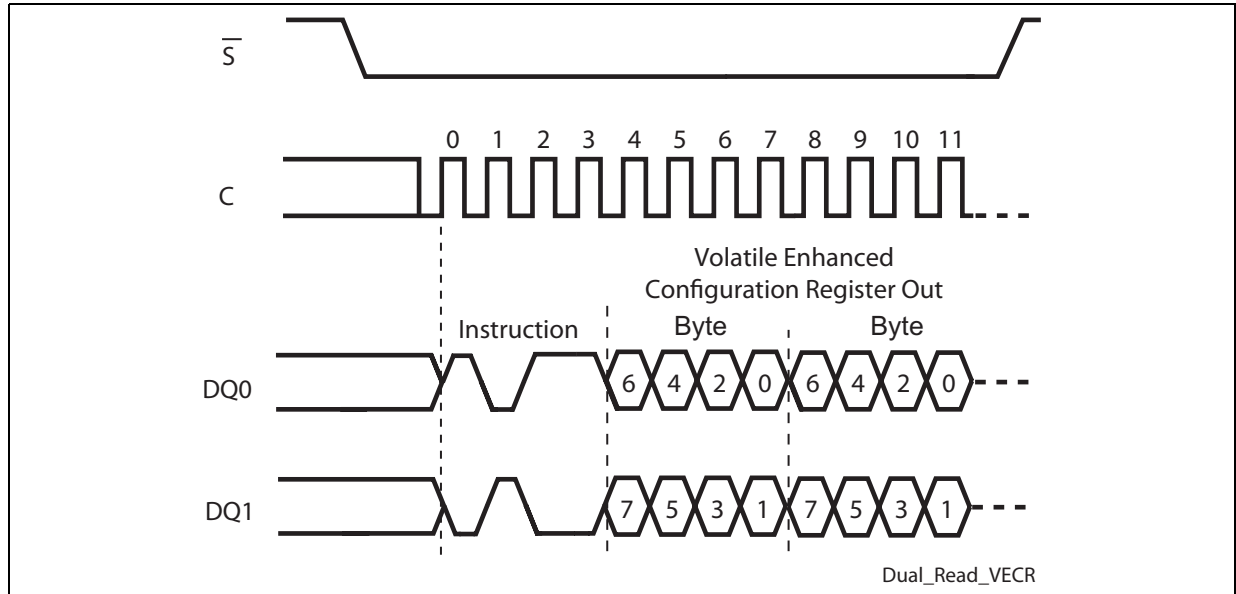

9.2.24 Write Volatile Enhanced Configuration Register

The Write Volatile Enhanced Configuration register (WRVECR) instruction allows new values to be written to the Volatile Enhanced Configuration register. Before it can be accepted, a write enable (WREN) instruction must previously have been executed. In case of Fast POR, the WREN instruction is not required because a WREN instruction gets the device out from the Fast POR state (See [Section 11.1: Fast POR](#)).

Apart from the parallelizing of the instruction code and the input data on the two pins DQ0 and DQ1, the instruction functionality is exactly the same as the Write Volatile Enhanced Configuration Register (WRVECR) instruction of the Extended SPI protocol, please refer to [Section 9.1.33: Write Volatile Enhanced Configuration Register](#) for further details.

Figure 69. Write Volatile Enhanced Configuration Register instruction sequence DIO-SPI

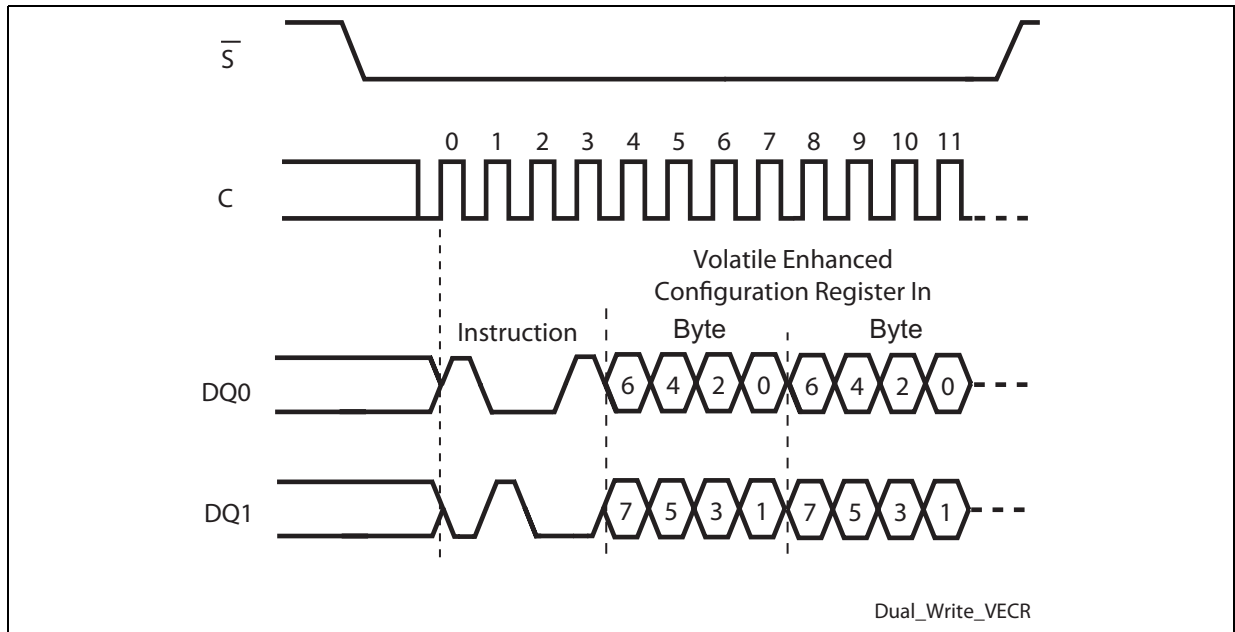

9.2.25 Deep Power-down (DP)

The Deep-Power-down (DP) instruction sets the device in Deep Power-down mode. Apart from the parallelizing of the instruction code on the two pins DQ0 and DQ1, the instruction functionality is exactly the same as the Deep Power-down (DP) instruction of the Extended SPI protocol. The instruction sequence is shown in [Figure 70: Deep Power-down instruction sequence](#).

Figure 70. Deep Power-down instruction sequence

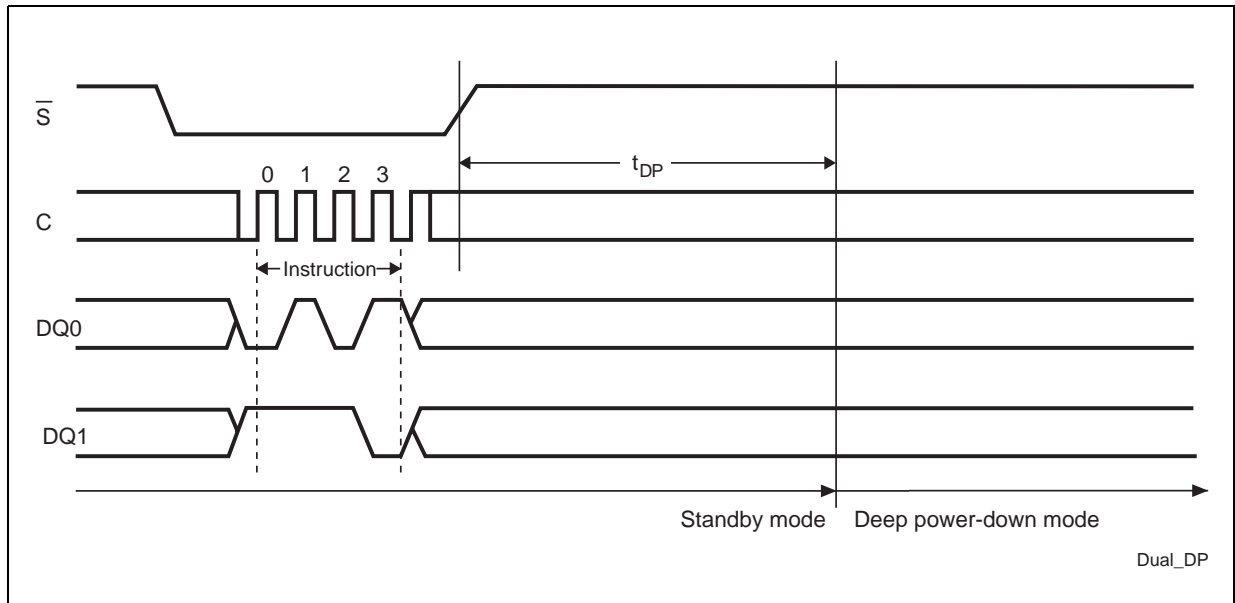

9.2.26 Release from Deep Power-down (RDP)

Once the device has entered the Deep Power-down mode, all instructions are ignored except the Release from Deep Power-down (RDP) instruction. Executing this instruction takes the device out of the Deep Power-down mode.

Apart from the parallelizing of the instruction code on the two pins DQ0 and DQ1, the instruction functionality is exactly the same as the Release from Deep-Power-down (RDP) instruction of the Extended SPI protocol. The instruction sequence is shown in [Figure 71: Release from Deep Power-down instruction sequence](#).

Figure 71. Release from Deep Power-down instruction sequence

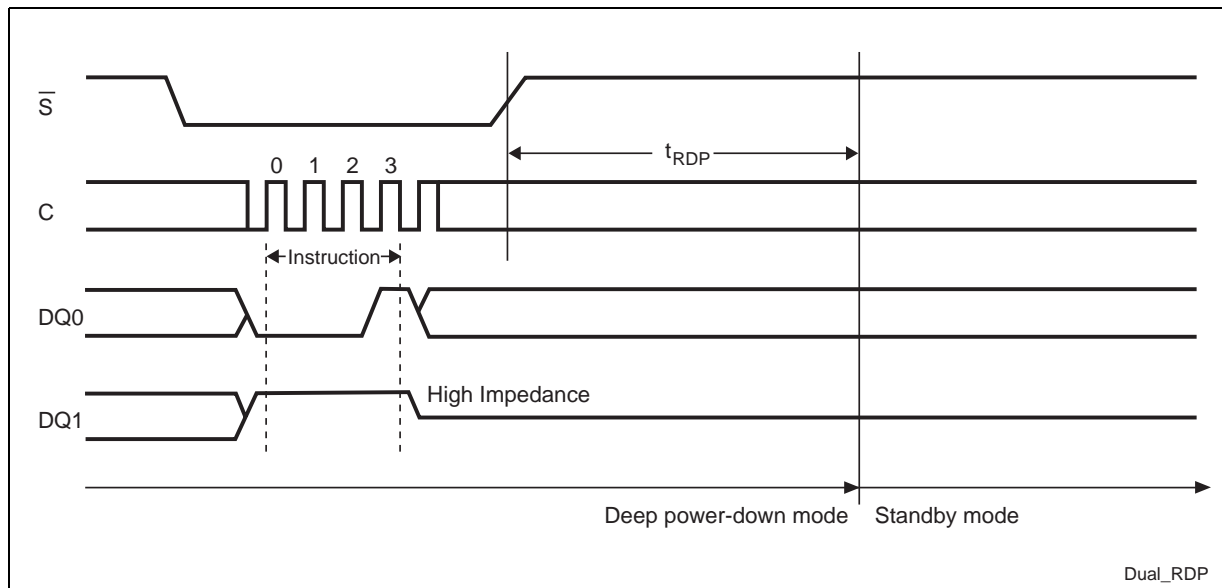

9.3 QIO-SPI Instructions

In QIO-SPI protocol, instructions, addresses and Input/Output data always run in parallel on four wires: DQ0, DQ1, DQ2 and DQ3 with the already mentioned exception of the modify instruction (erase and program) performed with the VPP=VPPh.

In the case of a Quad Command Fast Read (QCFR), Read OTP (ROTP), Read Lock Registers (RDLR), Read Status Register (RDSR), Read Flag Status Register (RFSR), Read NV Configuration Register (RDNVCR), Read Volatile Configuration Register (RDVCR), Read Volatile Enhanced Configuration Register (RDVECR) and Read Identification (RDID) instruction, the shifted-in instruction sequence is followed by a data-out sequence. Chip Select (\bar{S}) can be driven High after any bit of the data-out sequence is being shifted out.

In the case of a Quad Command Page Program (QCPP), Program OTP (POTP), Subsector Erase (SSE), Sector Erase (SE), Bulk Erase (BE), Program/Erase Suspend (PES), Program/Erase Resume (PER), Write Status Register (WRSR), Clear Flag Status Register (CLFSR), Write to Lock Register (WRLR), Write Configuration Register (WRVCR), Write Enhanced Configuration Register (WRVECR), Write NV Configuration Register (WRNVCR), Write Enable (WREN) or Write Disable (WRDI) instruction, Chip Select (\bar{S}) must be driven High exactly at a byte boundary, otherwise the instruction is rejected, and is not executed.

All attempts to access the memory array during a Write Status Register cycle, a Write Non Volatile Configuration Register, a Program cycle or an Erase cycle are ignored, and the internal Write Status Register cycle, Write Non Volatile Configuration Register, Program cycle or Erase cycle continues unaffected, the only exception is the Program/Erase Suspend instruction (PES), that can be used to pause all the program and the erase cycles but the Program OTP (POT), Bulk Erase (BE) and Write Non Volatile Configuration Register. The suspended program or erase cycle can be resumed by mean of the Program/Erase Resume instruction (PER). During the program/erase cycles also the polling instructions (to check if the internal modify cycle is finished by mean of the WIP bit of the Status Register or of the Program/Erase controller bit of the Flag Status register) are also accepted to allow the application checking the end of the internal modify cycles, of course these polling instructions don't affect the internal cycles performing.

Table 24. Instruction set: QIO-SPI protocol (page 1 of 2)

Instruction	Description	One-byte Instruction Code (BIN)	One-byte Instruction Code (HEX)	Address bytes	Dummy clock cycle	Data bytes
MIORDID	Multiple I/O read identification	1010 1111	AFh	0	0	1 to 3
QCFR	Quad Command Fast Read	0000 1011	0Bh	3	10 ⁽¹⁾	1 to ∞
		0110 1011	6Bh	3	10 ⁽¹⁾	1 to ∞
		1110 1011	EBh	3	10 ⁽¹⁾	1 to ∞
ROTP	Read OTP (Read of OTP area)	0100 1011	4Bh	3	10 ⁽¹⁾	1 to 65
WREN	Write Enable	0000 0110	06h	0	0	0
WRDI	Write Disable	0000 0100	04h	0	0	0
QCPP	Quad Command Page Program	0000 0010	02h	3	0	1 to 256
		0011 0010	32h	3	0	1 to 256
		0001 0010	12h	3	0	1 to 256
POTP	Program OTP (Program of OTP area)	0100 0010	42h	3	0	1 to 65
SSE ⁽²⁾	SubSector Erase	0010 0000	20h	3	0	0
SE	Sector Erase	1101 1000	D8h	3	0	0
BE	Bulk Erase	1100 0111	C7h	0	0	0
PER	Program/Erase Resume	0111 1010	7Ah	0	0	0
PES	Program/Erase Suspend	0111 0101	75h	0	0	0
RDSR	Read Status Register	0000 0101	05h	0	0	1 to ∞
WRSR	Write Status Register	0000 0001	01h	0	0	1
RDLR	Read Lock Register	1110 1000	E8h	3	0	1 to ∞
WRLR	Write to Lock Register	1110 0101	E5h	3	0	1
RFSR	Read Flag Status Register	0111 0000	70h	0	0	1 to ∞
CLFSR	Clear Flag Status Register	0101 0000	50h	0	0	0
RDNVCR	Read NV Configuration Register	1011 0101	B5h	0	0	2

Table 24. Instruction set: QIO-SPI protocol (page 2 of 2)

Instruction	Description	One-byte Instruction Code (BIN)	One-byte Instruction Code (HEX)	Address bytes	Dummy clock cycle	Data bytes
WRNVCR	Write NV Configuration Register	1011 0001	B1h	0	0	2
RDVCR	Read Volatile Configuration Register	1000 0101	85h	0	0	1 to ∞
WRVCR	Write Volatile Configuration Register	1000 0001	81h	0	0	1
RDVECR	Read Volatile Enhanced Configuration Register	0110 0101	65h	0	0	1 to ∞
WRVECR	Write Volatile Enhanced Configuration Register	0110 0001	61h	0	0	1
DP	Deep Power-down	1011 1001	B9h	0	0	0
RDP	Release from Deep Power-down	1010 1011	ABh	0	0	0

- 1) The number of Dummy Clock cycles is configurable by the user.
- 2) SSE is only available in devices with Bottom or Top architecture

9.3.1 Multiple I/O Read Identification (MIORDID)

The Multiple Input/Output Read Identification (MIORDID) instruction allows to read the device identification data in the QIO-SPI protocol:

- Manufacturer identification (1 byte)
- Device identification (2 bytes)

Unlike the RDID instruction of the Extended SPI protocol, the Multiple Input/Output instruction can not read the Unique ID code (UID) (17 bytes).

For further details on the manufacturer and device identification codes, see [9.1.1: Read Identification \(RDID\)](#).

Any Multiple Input/Output Read Identification (MIORDID) instruction while an Erase or Program cycle is in progress, is not decoded, and has no effect on the cycle that is in progress.

The device is first selected by driving Chip Select (\overline{S}) Low. Then, the 8-bit instruction code for the instruction is shifted in parallel on the 4 pins DQ0, DQ1, DQ2 and DQ3. After this, the 24-bit device identification, stored in the memory, will be shifted out on again in parallel on DQ0, DQ1, DQ2 and DQ3. The identification bits are shifted out 4 at a time during the falling edge of Serial Clock (C).

The Read Identification (RDID) instruction is terminated by driving Chip Select (\overline{S}) High at any time during data output.

When Chip Select (\overline{S}) is driven High, the device is put in the Standby Power mode. Once in the Standby Power mode, the device waits to be selected, so that it can receive, decode and execute instructions.

Multiple I/O Read Identification (MIORDID) instruction sequence and data-out sequence QIO-SPI.

Figure 72. Multiple I/O Read Identification instruction and data-out sequence QIO-SPI

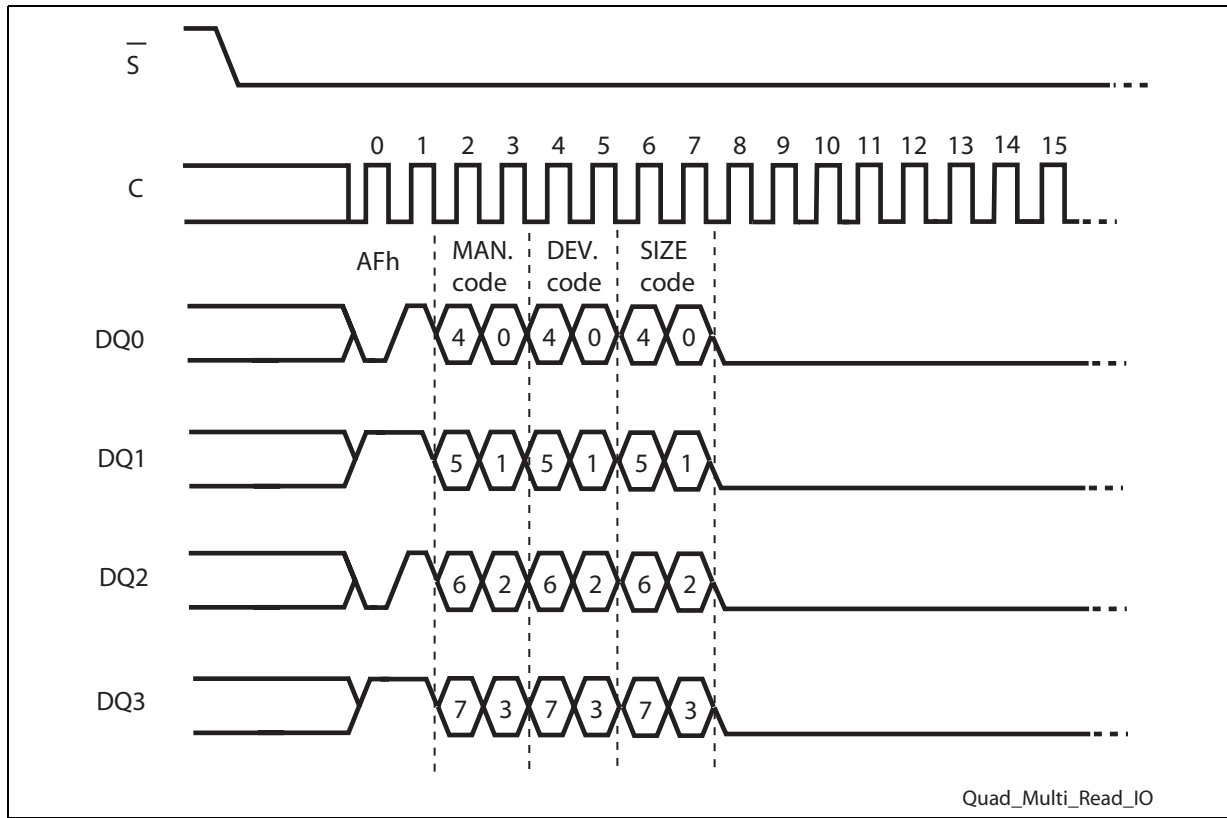

9.3.2 Quad Command Fast Read (QCFR)

The Quad Command Fast Read (QCFR) instruction allows to read the memory in QIO-SPI protocol, parallelizing the instruction code, the address and the output data on four pins (DQ0, DQ1, DQ2 and DQ3). The Quad Command Fast Read (QCFR) instruction can be issued, after the device is set in QIO-SPI mode, by sending to the memory indifferently one of the 3 instructions codes: 0Bh, 6Bh or EBh, the effect is exactly the same. The 3 instruction codes are all accepted to help the application code porting from Extended SPI protocol to QIO-SPI protocol.

Apart for the parallelizing on four pins of the instruction code, the Quad Command Fast Read instruction functionality is exactly the same as the Quad I/O Fast Read of the Extended SPI protocol, please refer to [Section 9.1.7: Quad I/O Fast Read](#) for further details.

Figure 73. Quad Command Fast Read instruction and data-out sequence QSP, 0Bh

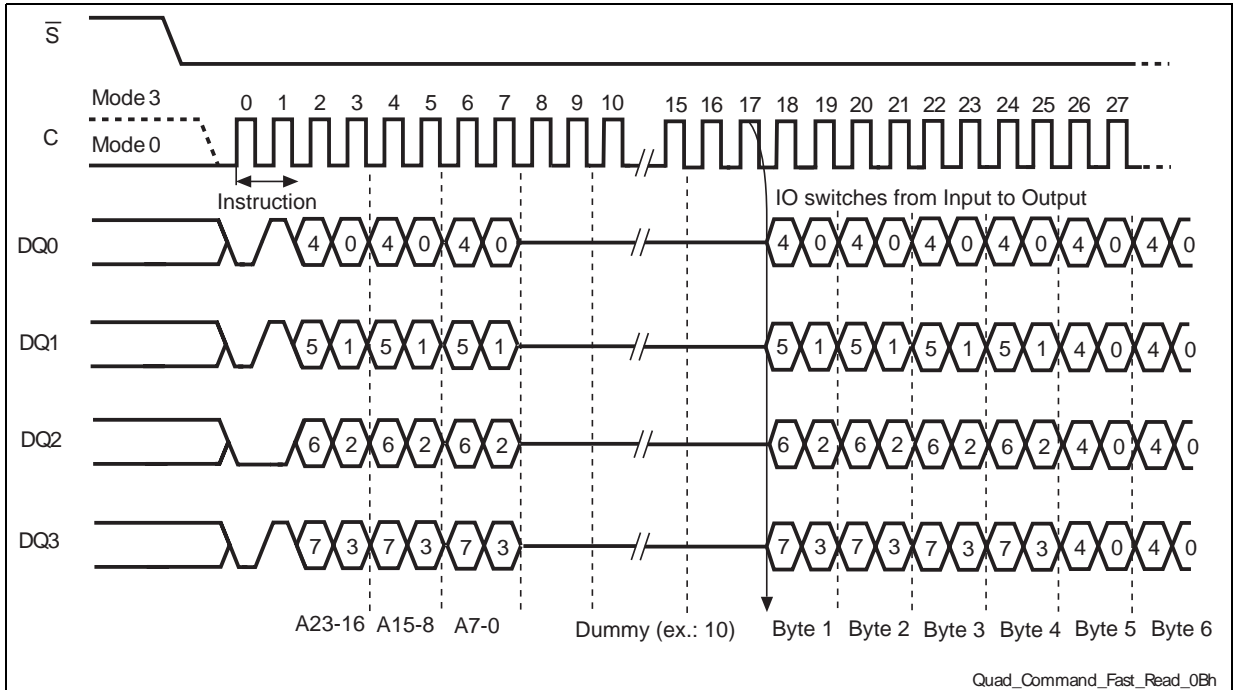

Figure 74. Quad Command Fast Read instruction and data-out sequence QSP, 6Bh

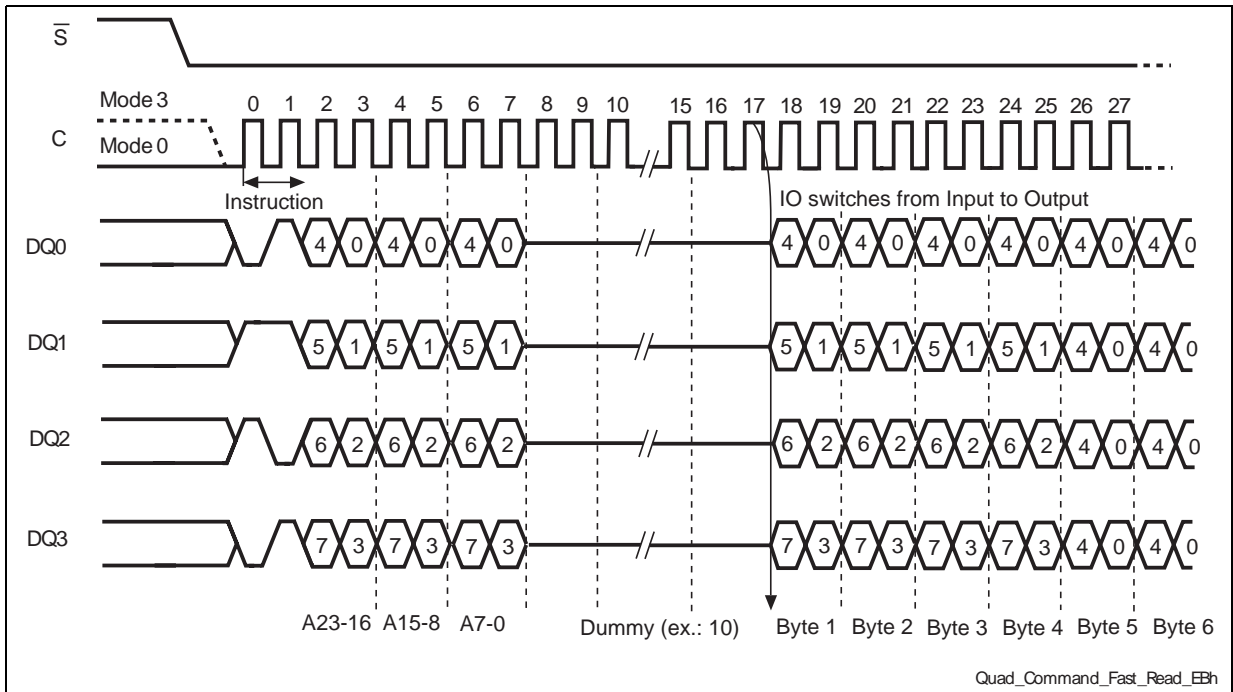
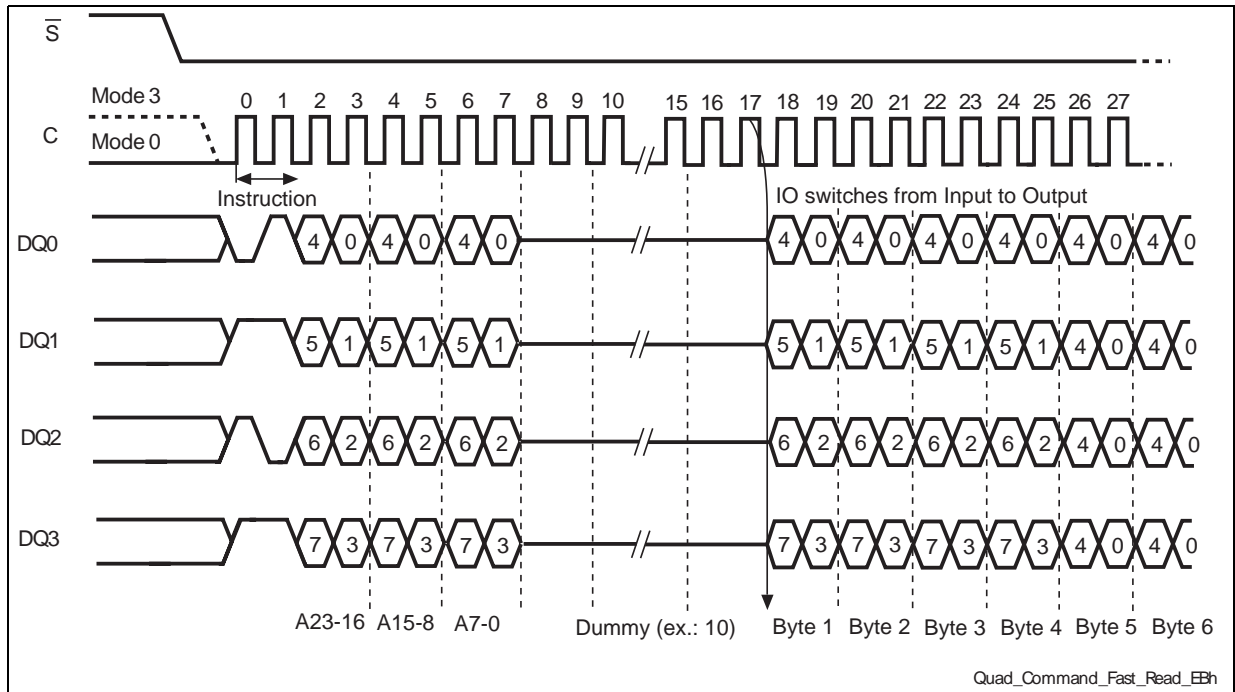

Figure 75. Quad Command Fast Read instruction and data-out sequence QSP, EBh



9.3.3 Read OTP (ROTP)

The Read OTP (ROTP) instruction is used to read the 64 bytes OTP area in the QIO-SPI protocol. The instruction functionality is exactly the same as the Read OTP instruction of the Extended SPI protocol. The only difference is that in the QIO-SPI protocol instruction code, address and output data are all parallelized on the four pins DQ0, DQ1, DQ2 and DQ3.

Note: The dummy byte bits can not be parallelized: 8 clock cycles are requested to perform the internal reading operation.

Figure 76. Read OTP instruction and data-out sequence QIO-SPI

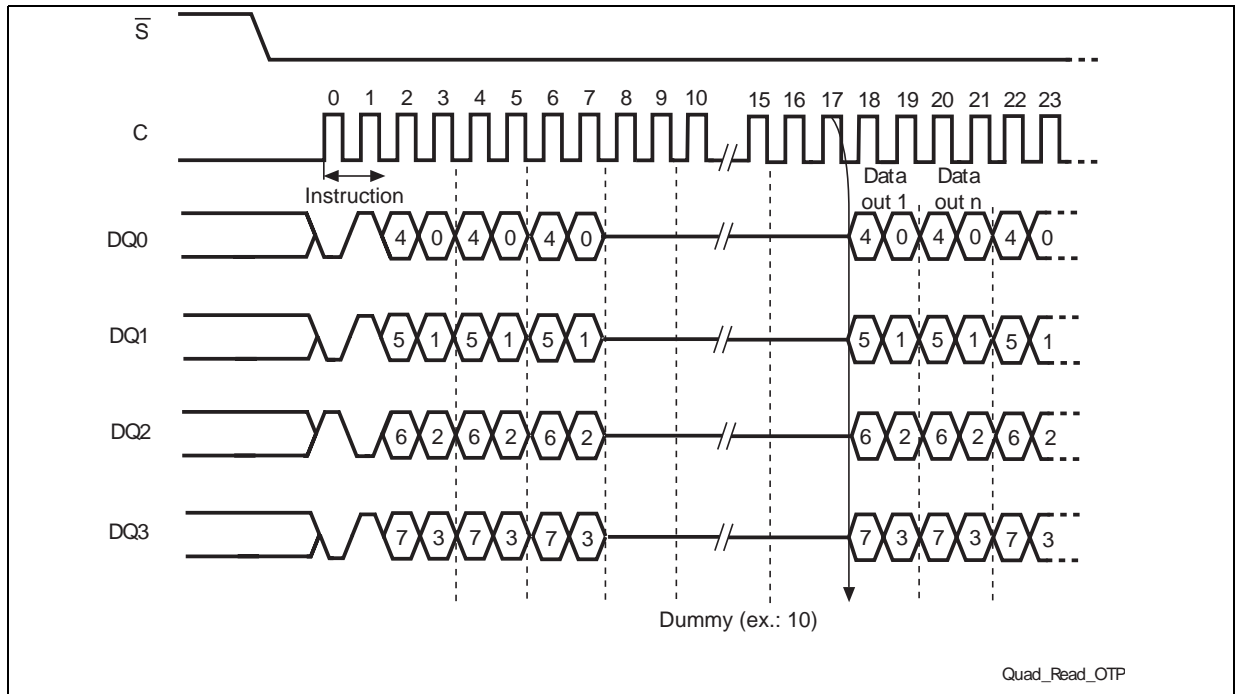

9.3.4 Write Enable (WREN)

The Write Enable (WREN) instruction sets the Write Enable Latch (WEL) bit. Apart from the parallelizing of the instruction code on the four pins DQ0, DQ1, DQ2 and DQ3, the instruction functionality is exactly the same as the Write Enable instruction of the Extended SPI protocol, please refer to [Section 9.1.9: Write Enable \(WREN\)](#) for further details.

Figure 77. Write Enable instruction sequence QIO-SPI

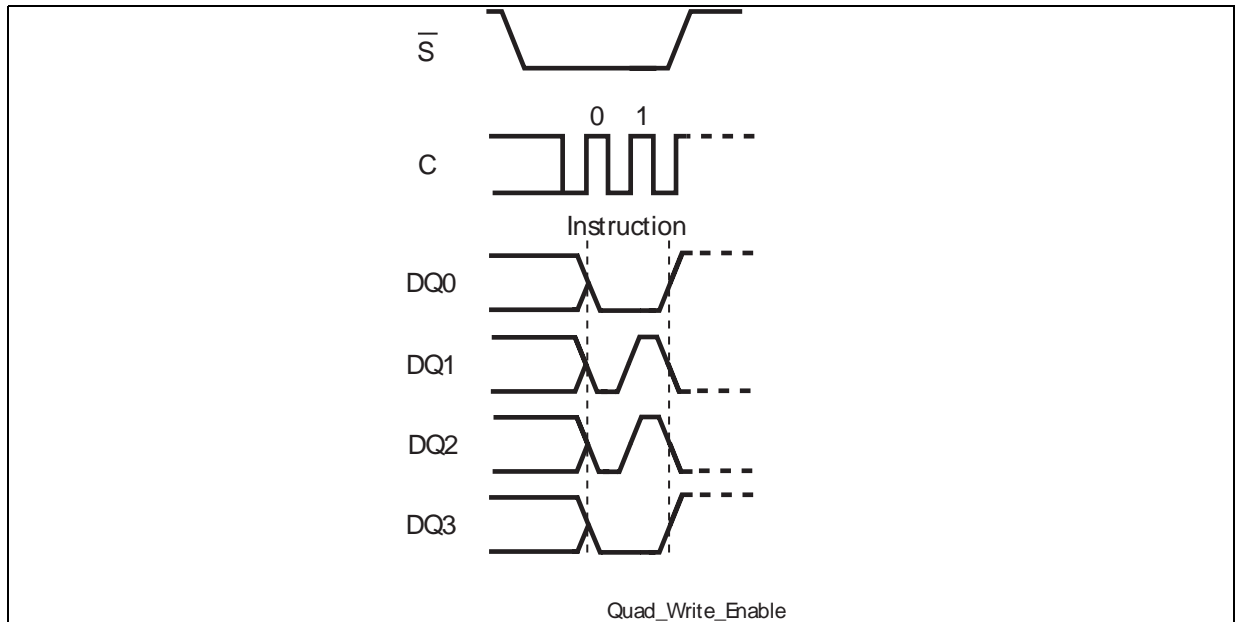

9.3.5 Write Disable (WRDI)

The Write Disable (WRDI) instruction resets the Write Enable Latch (WEL) bit.

Apart from the parallelizing of the instruction code on the four pins DQ0, DQ1, DQ2 and DQ3, the instruction functionality is exactly the same as the Write Disable (WRDI) instruction of the Extended SPI protocol, please refer to [Section 9.1.10: Write Disable \(WRDI\)](#) for further details.

Figure 78. Write Disable instruction sequence QIO-SPI

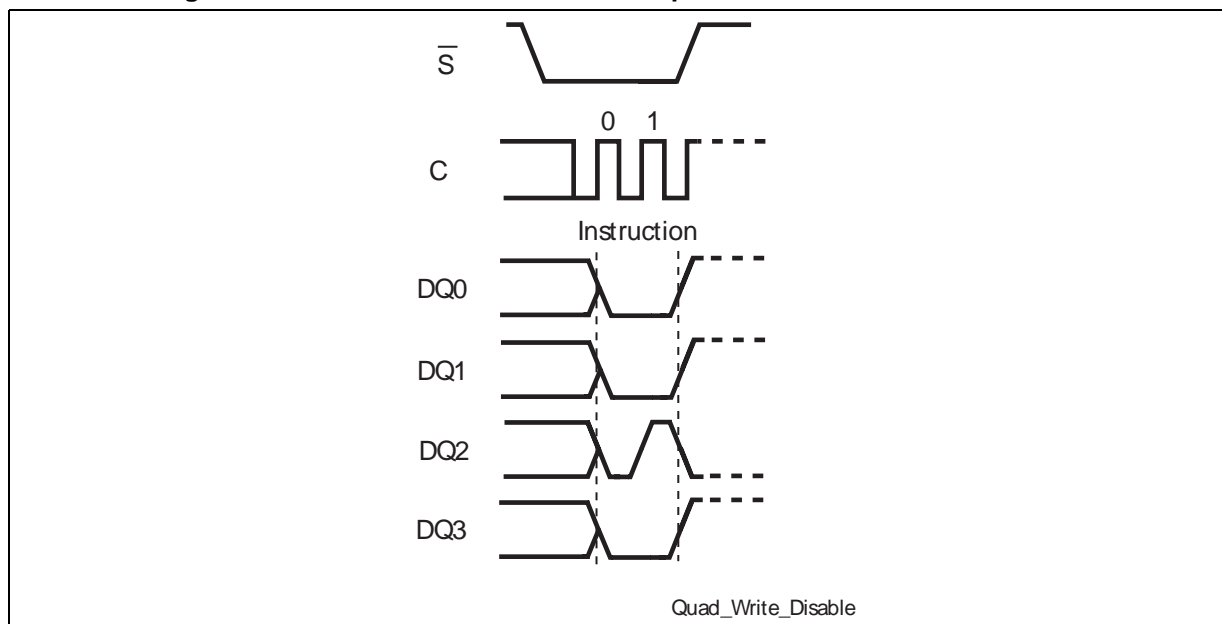

9.3.6 Quad Command Page Program (QCPP)

The Quad Command Page Program (QCPP) instruction allows to program the memory content in QIO-SPI protocol, parallelizing the instruction code, the address and the input data on four pins (DQ0, DQ1, DQ2 and DQ3). Before it can be accepted, a Write Enable (WREN) instruction must previously have been executed. The Quad Command Page Program (QCPP) instruction can be issued, when the device is set in QIO-SPI mode, by sending to the memory indifferently one of the 3 instructions codes: 02h, 12h or 32h, the effect is exactly the same. The 3 instruction codes are all accepted to help the application code porting from Extended SPI protocol to QIO-SPI protocol.

Apart from the parallelizing on four pins of the instruction code, the Quad Command Page Program instruction functionality is exactly the same as the Quad Input Extended Fast Program of the Extended SPI protocol, please refer to [Section 9.1.15: Quad Input Extended Fast Program](#) for further details.

Figure 81. Quad Command Page Program instruction sequence QIO-SPI, 32h

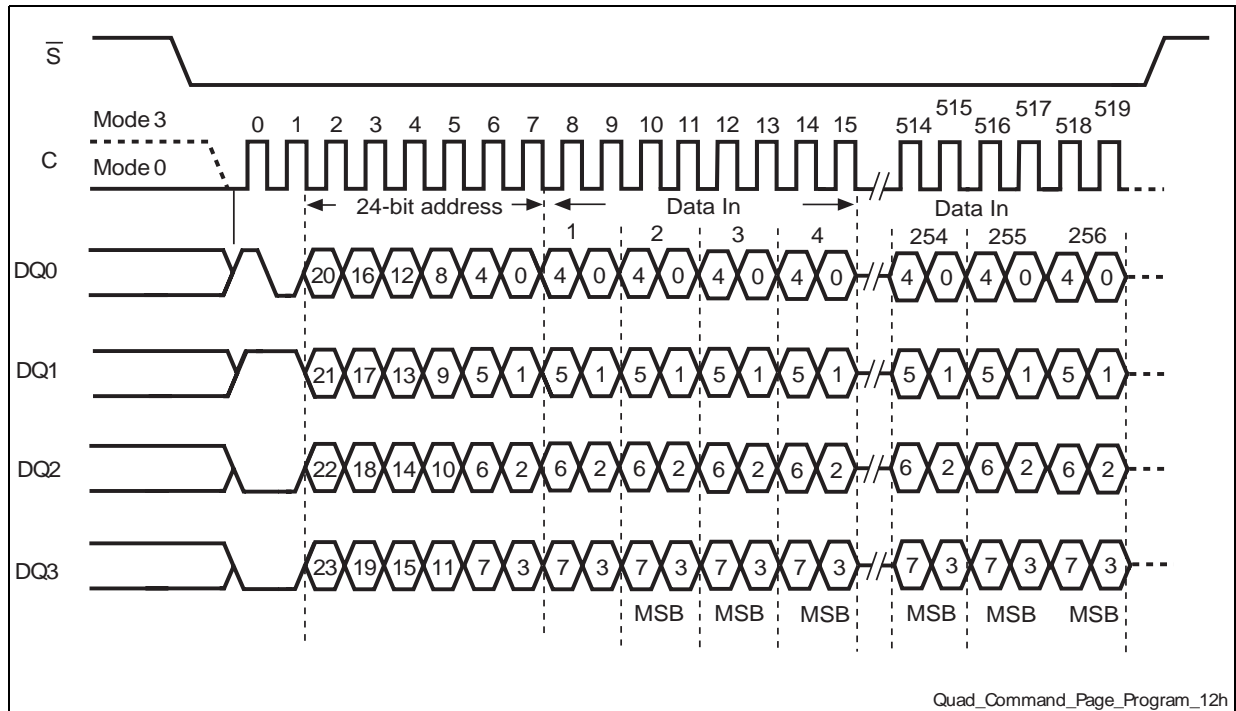

9.3.7 Program OTP instruction (POTP)

The Program OTP instruction (POTP) is used to program at most 64 bytes to the OTP memory area (by changing bits from 1 to 0, only). Before it can be accepted, a Write Enable (WREN) instruction must previously have been executed.

Apart from the parallelizing of the instruction code, address and input data on the four pins DQ0, DQ1, DQ2 and DQ3, the instruction functionality (as well as the locking OTP method) is exactly the same as the Program OTP (POTP) instruction of the Extended SPI protocol, please refer to [Section 9.1.16: Program OTP instruction \(POTP\)](#) for further details.

Figure 82. Program OTP instruction sequence QIO-SPI

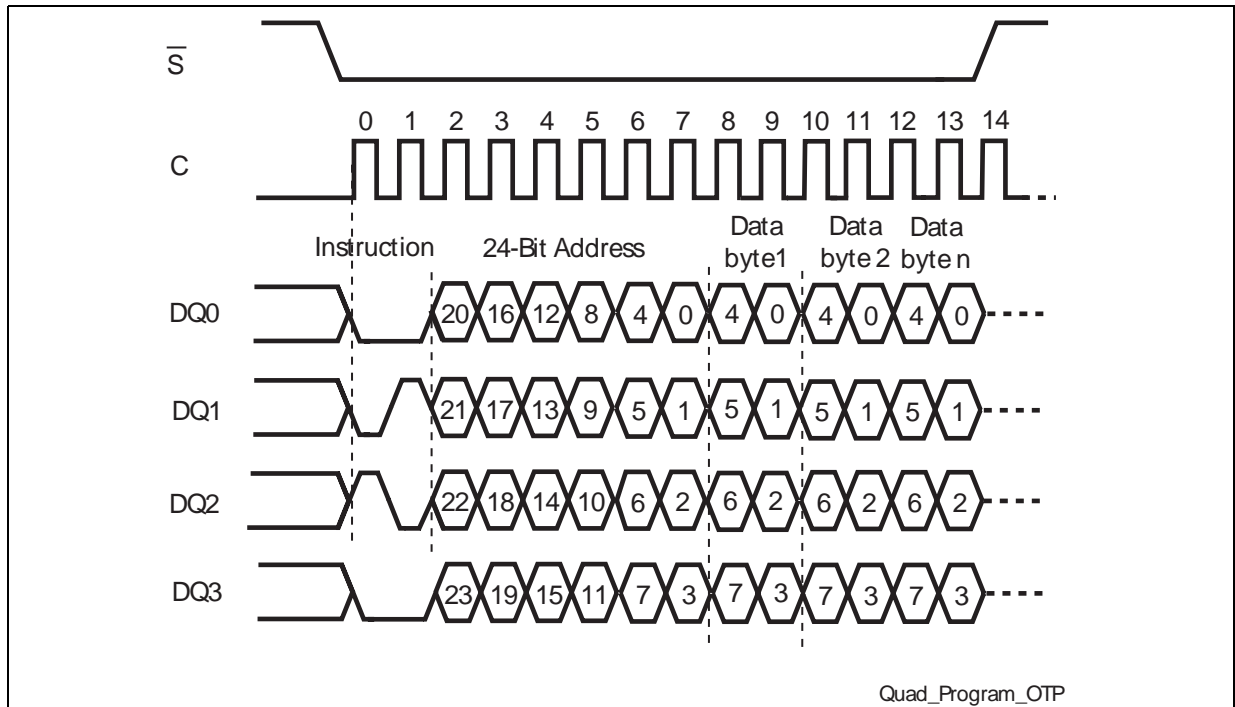

9.3.8 Subsector Erase (SSE)

For devices with a dedicated part number, at the bottom (or top) of the addressable area there are 8 boot sectors, each one having 16 4Kbytes subsectors. (See [Section 16: Ordering information](#).) The Subsector Erase (SSE) instruction sets to '1' (FFh) all bits inside the chosen subsector. Before it can be accepted, a Write Enable (WREN) instruction must previously have been executed.

Apart from the parallelizing of the instruction code and the address on the four pins DQ0, DQ1, DQ2 and DQ3, the instruction functionality is exactly the same as the Subsector Erase (SSE) instruction of the Extended SPI protocol, please refer to [Section 9.1.17: Subsector Erase \(SSE\)](#) for further details.

Figure 83. Subsector Erase instruction sequence QIO-SPI

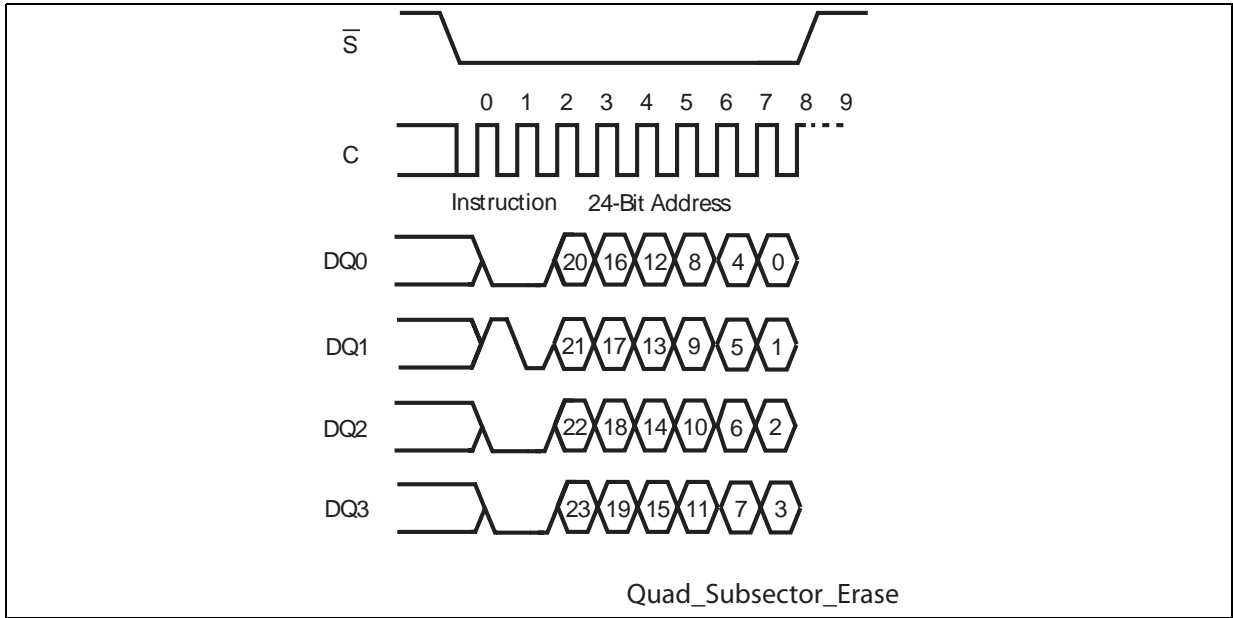

9.3.9 Sector Erase (SE)

The Sector Erase (SE) instruction sets to '1' (FFh) all bits inside the chosen sector. Before it can be accepted, a Write Enable (WREN) instruction must previously have been executed.

Apart from the parallelizing of the instruction code and the address on the four pins DQ0, DQ1, DQ2 and DQ3, the instruction functionality is exactly the same as the Sector Erase (SE) instruction of the Extended SPI protocol, please refer to [Section 9.1.18: Sector Erase \(SE\)](#) for further details.

Figure 84. Sector Erase instruction sequence QIO-SPI

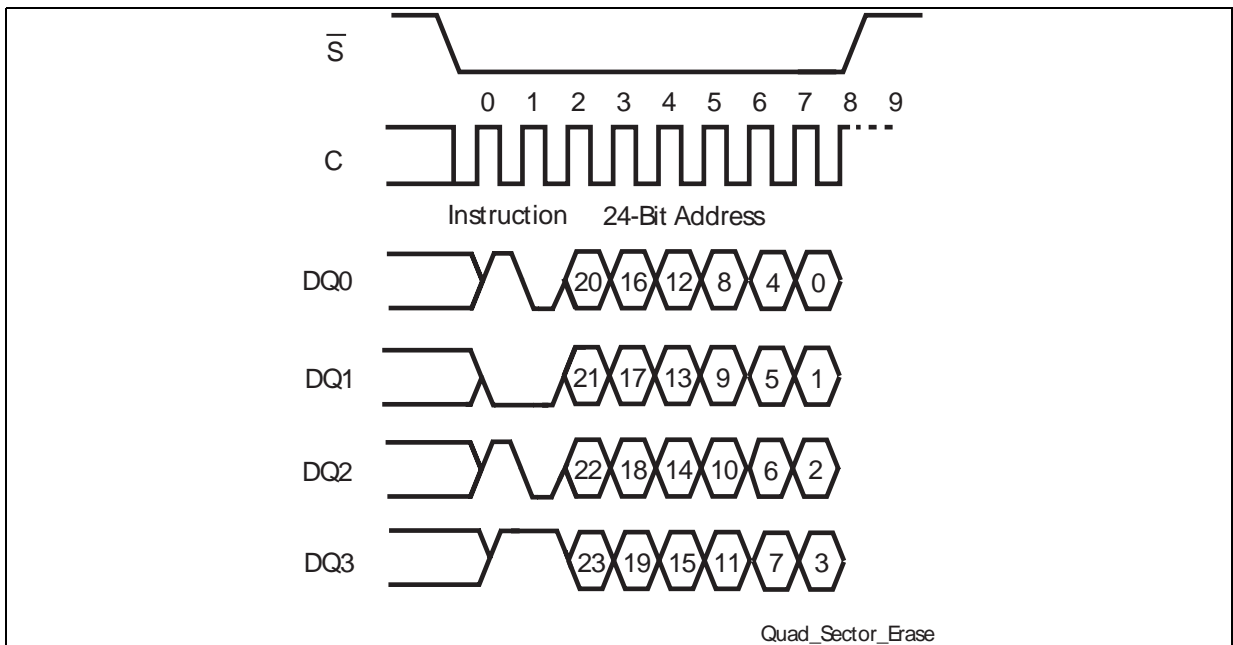

9.3.10 Bulk Erase (BE)

The Bulk Erase (BE) instruction sets all bits to '1' (FFh). Before it can be accepted, a Write Enable (WREN) instruction must previously have been executed.

Apart from the parallelizing of the instruction code on the four pins DQ0, DQ1, DQ2 and DQ3, the instruction functionality is exactly the same as the Bulk Erase (BE) instruction of the Extended SPI protocol, please refer to [Section 9.1.19: Bulk Erase \(BE\)](#) for further details.

Figure 85. Bulk Erase instruction sequence QIO-SPI

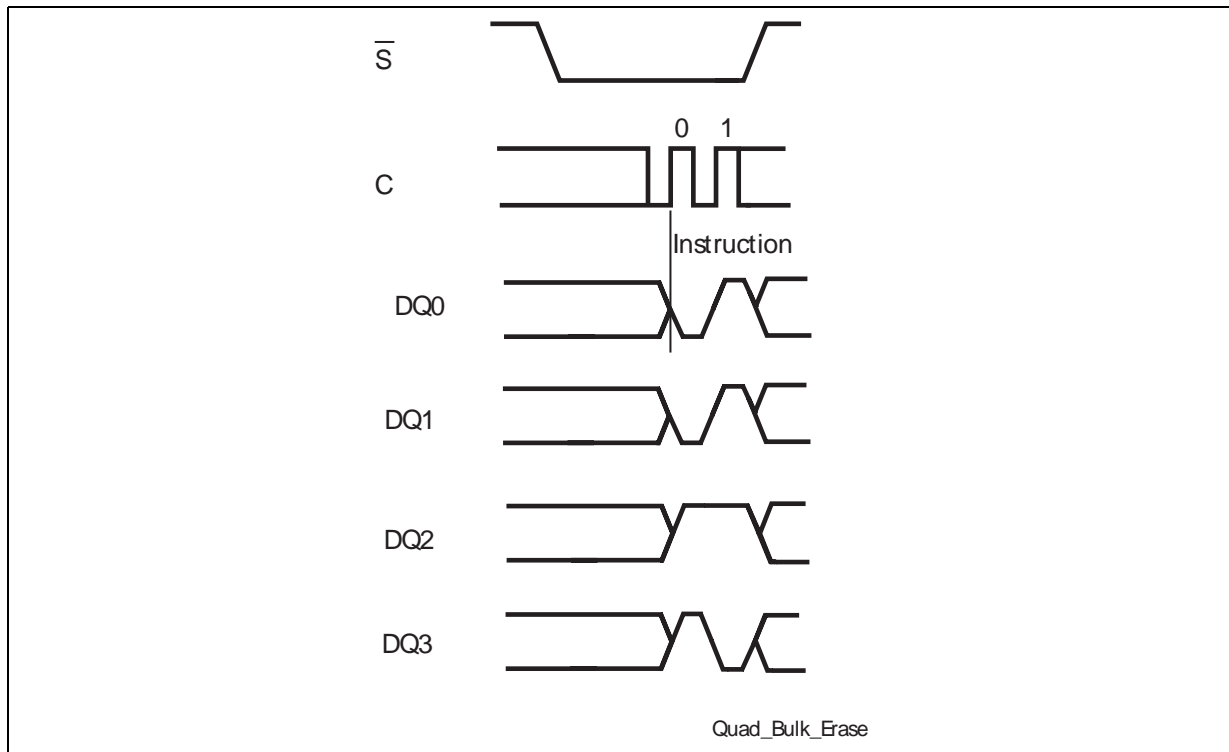

9.3.11 Program/Erase Suspend

The Program/Erase Suspend instruction allows the controller to interrupt a Program or an Erase instruction, in particular: Sector Erase and Quad Command Page Program can be suspended and erased while that Subsector Erase, Bulk Erase, Write Non Volatile Configuration register and Program OTP can not be suspended.

Apart from the parallelizing of the instruction code on the four pins DQ0, DQ1, DQ2 and DQ3, the instruction functionality is exactly the same as the Program/Erase Suspend (PES) instruction of the Extended SPI protocol, please refer to [Section 9.1.20: Program/Erase Suspend](#) for further details.

Figure 86. Program/Erase Suspend instruction sequence QIO-SPI

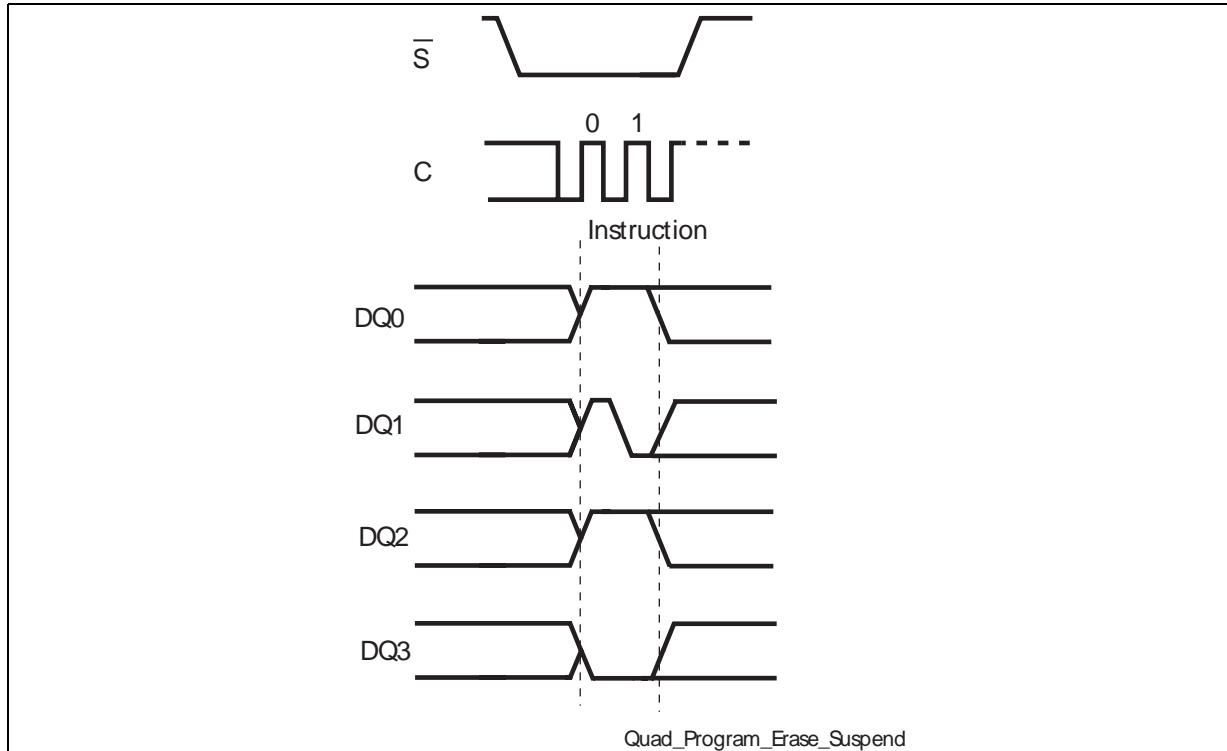

9.3.12 Program/Erase Resume

After a Program/Erase suspend instruction, a Program/Erase Resume instruction is required to continue performing the suspended Program or Erase sequence.

Apart from the parallelizing of the instruction code on the four pins $DQ0$, $DQ1$, $DQ2$ and $DQ3$, the instruction functionality is exactly the same as the Program/Erase Resume (PER) instruction of the Extended SPI protocol, please refer to [Section 9.1.21: Program/Erase Resume](#) for further details.

Figure 87. Program/Erase Resume instruction sequence QIO-SPI

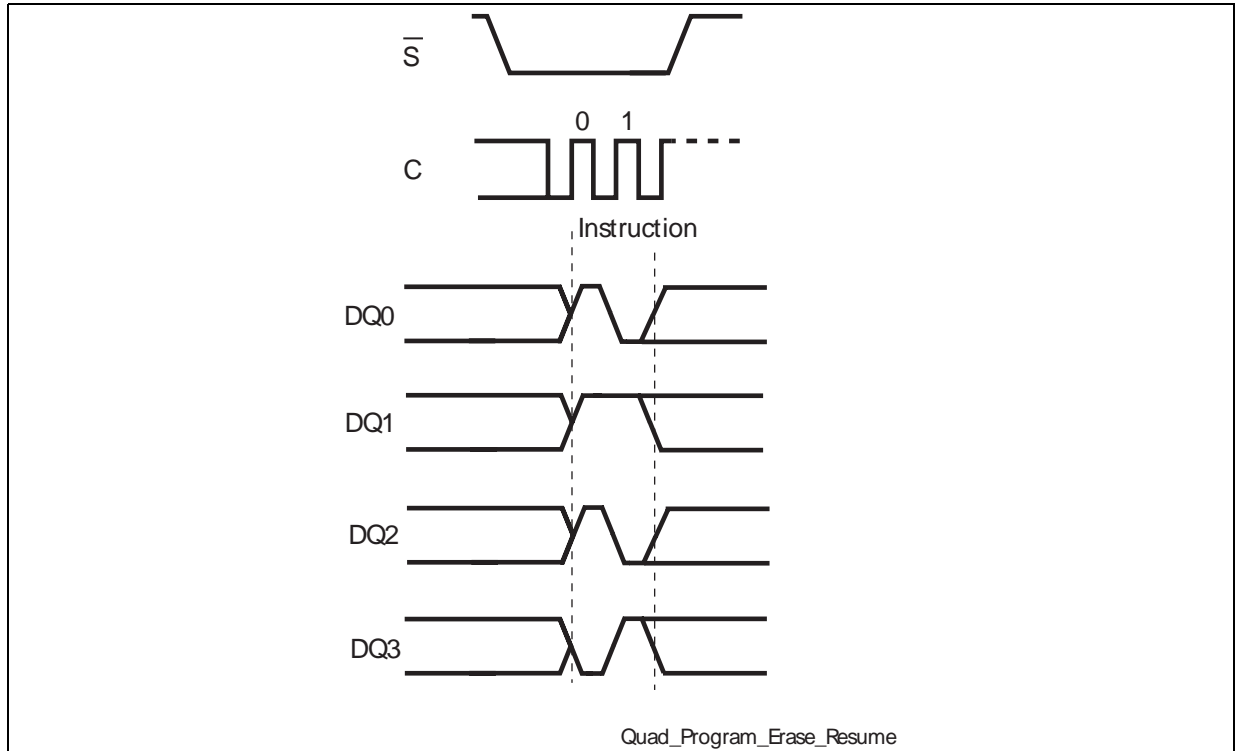

9.3.13 Read Status Register (RDSR)

The Read Status Register (RDSR) instruction allows the Status Register to be read.

Apart from the parallelizing of the instruction code and the output data on the four pins $DQ0$, $DQ1$, $DQ2$ and $DQ3$, the instruction functionality is exactly the same as the Read Status Register (RDSR) instruction of the Extended SPI protocol, please refer to [Section 9.1.22: Read Status Register \(RDSR\)](#) for further details.

Figure 88. Read Status Register instruction sequence QIO-SPI

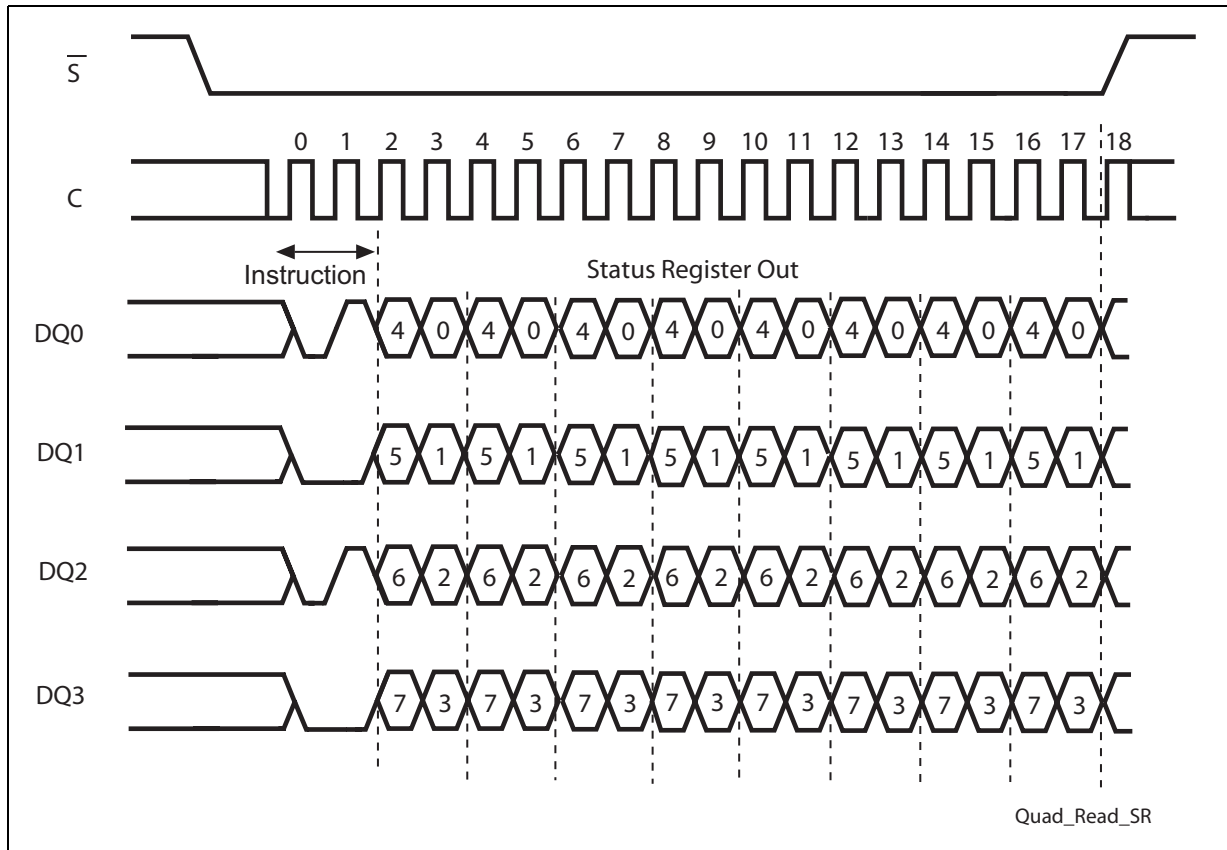

9.3.14 Write status register (WRSR)

The write status register (WRSR) instruction allows new values to be written to the status register. Before it can be accepted, a write enable (WREN) instruction must previously have been executed.

The instruction code and the input data are sent on four pins DQ0, DQ1, DQ2 and DQ3. The instruction functionality is exactly the same as the Write Status Register (WRSR) instruction of the Extended SPI protocol (See [Section 9.1.23: Write status register \(WRSR\)](#)). However, the protection feature management is different. In particular, once SRWD bit is set to '1' the device enters in the hardware protected mode (HPM) independently from Write Protect (W/VPP) signal value. To exit the HPM mode is needed to switch temporarily to the Extended SPI protocol.

Figure 89. Write Status Register instruction sequence QIO-SPI

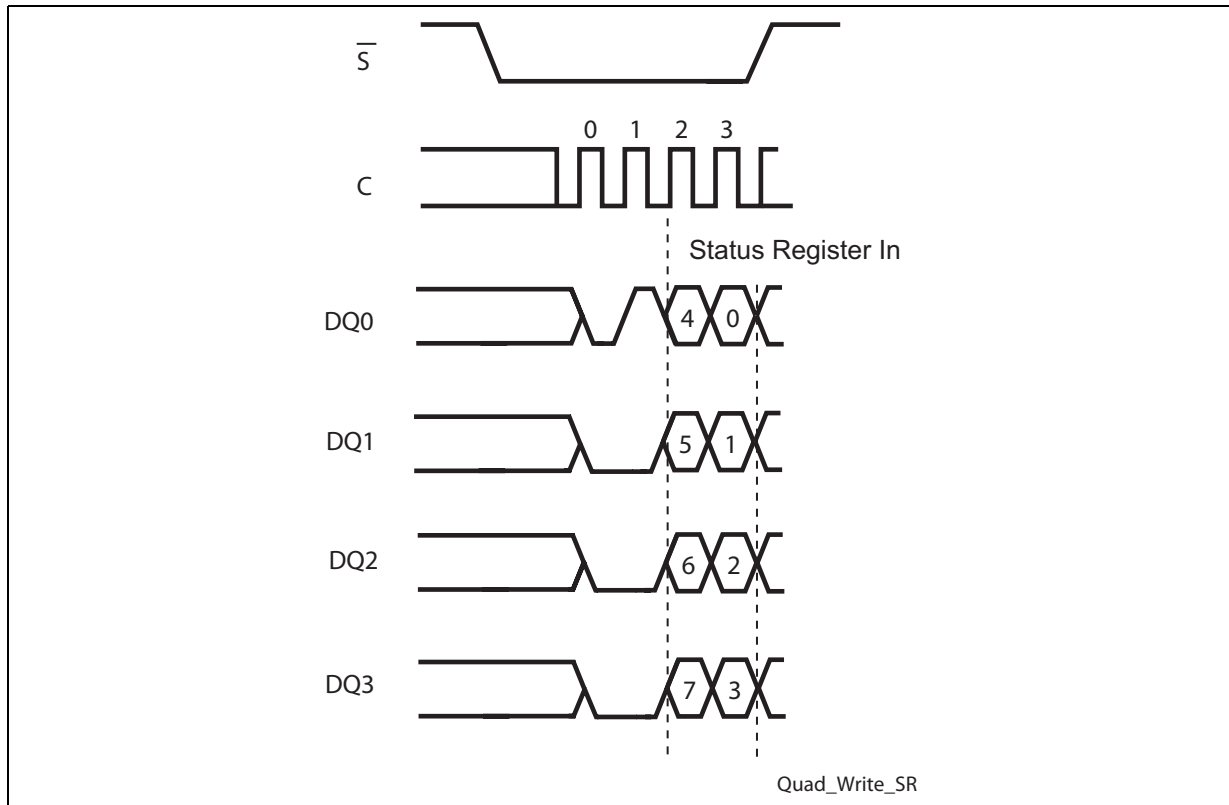

9.3.15 Read Lock Register (RDLR)

The Read Lock Register instructions is used to read the lock register content.

Apart from the parallelizing of the instruction code, the address and the output data on the four pins DQ0, DQ1, DQ2 and DQ3, the instruction functionality is exactly the same as the Read Lock Register (RDLR) instruction of the Extended SPI protocol, please refer to [Section 9.1.24: Read Lock Register \(RDLR\)](#) for further details.

Figure 90. Read Lock Register instruction and data-out sequence QIO-SPI

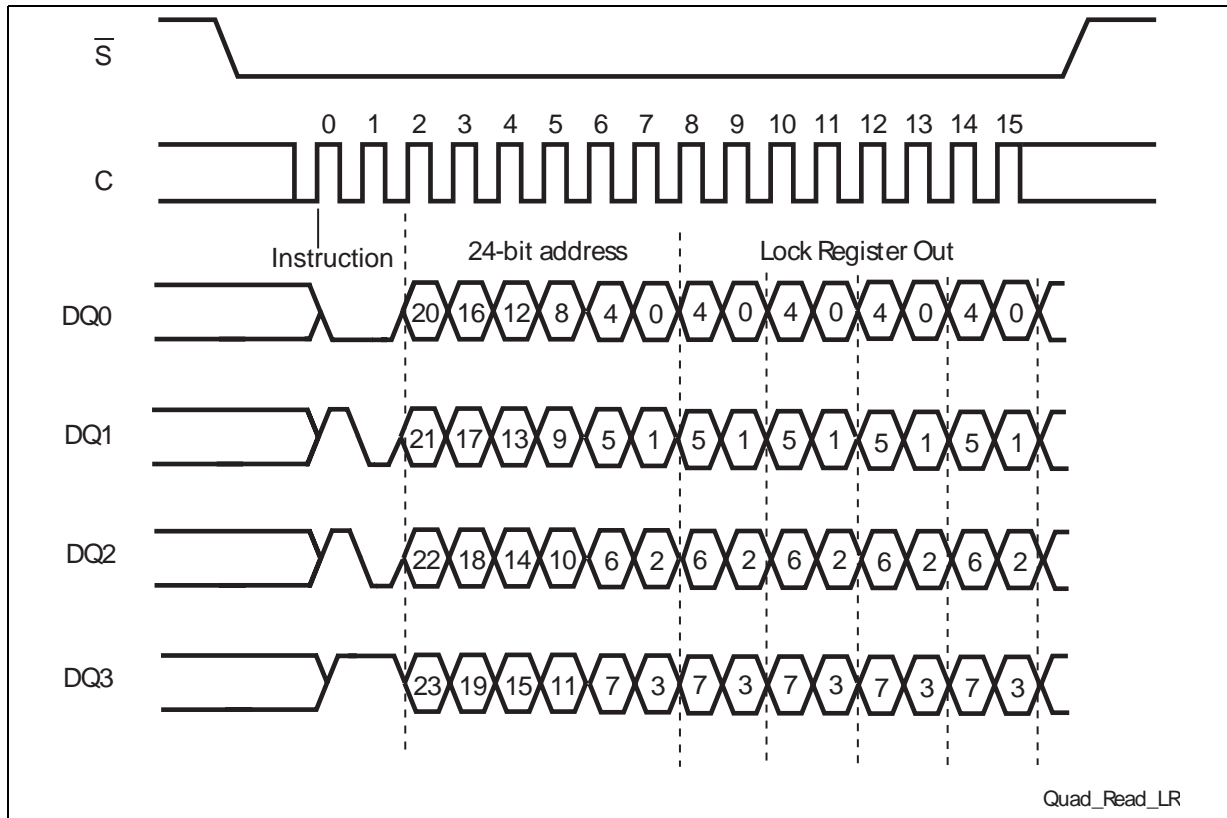

9.3.16 Write to Lock Register (WRLR)

The Write to Lock Register (WRLR) instruction allows bits to be changed in the Lock Registers. Before it can be accepted, a Write Enable (WREN) instruction must previously have been executed.

Apart from the parallelizing of the instruction code, the address and the input data on the four pins DQ0, DQ1, DQ2 and DQ3, the instruction functionality is exactly the same as the Write to Lock Register (WRLR) instruction of the Extended SPI protocol, please refer to [Section 9.1.25: Write to Lock Register \(WRLR\)](#) for further details.

Figure 91. Write to Lock Register instruction sequence QIO-SPI

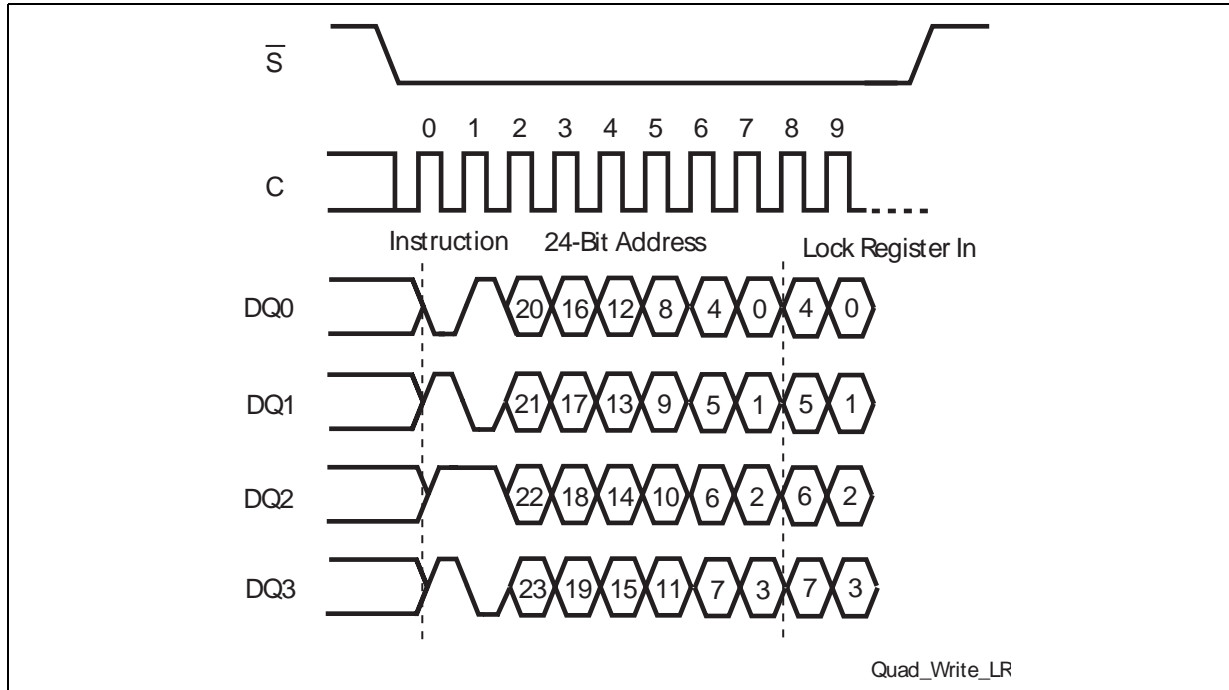

9.3.17 Read Flag Status Register

The Read Flag Status Register (RFSR) instruction allows the Flag Status Register to be read.

Apart from the parallelizing of the instruction code and the output data on the four pins DQ0, DQ1, DQ2 and DQ3, the instruction functionality is exactly the same as the Read Flag Status Register (RFSR) instruction of the Extended SPI protocol, please refer to [Section 9.1.26: Read Flag Status Register](#) for further details.

Figure 92. Read Flag Status Register instruction sequence QIO-SPI

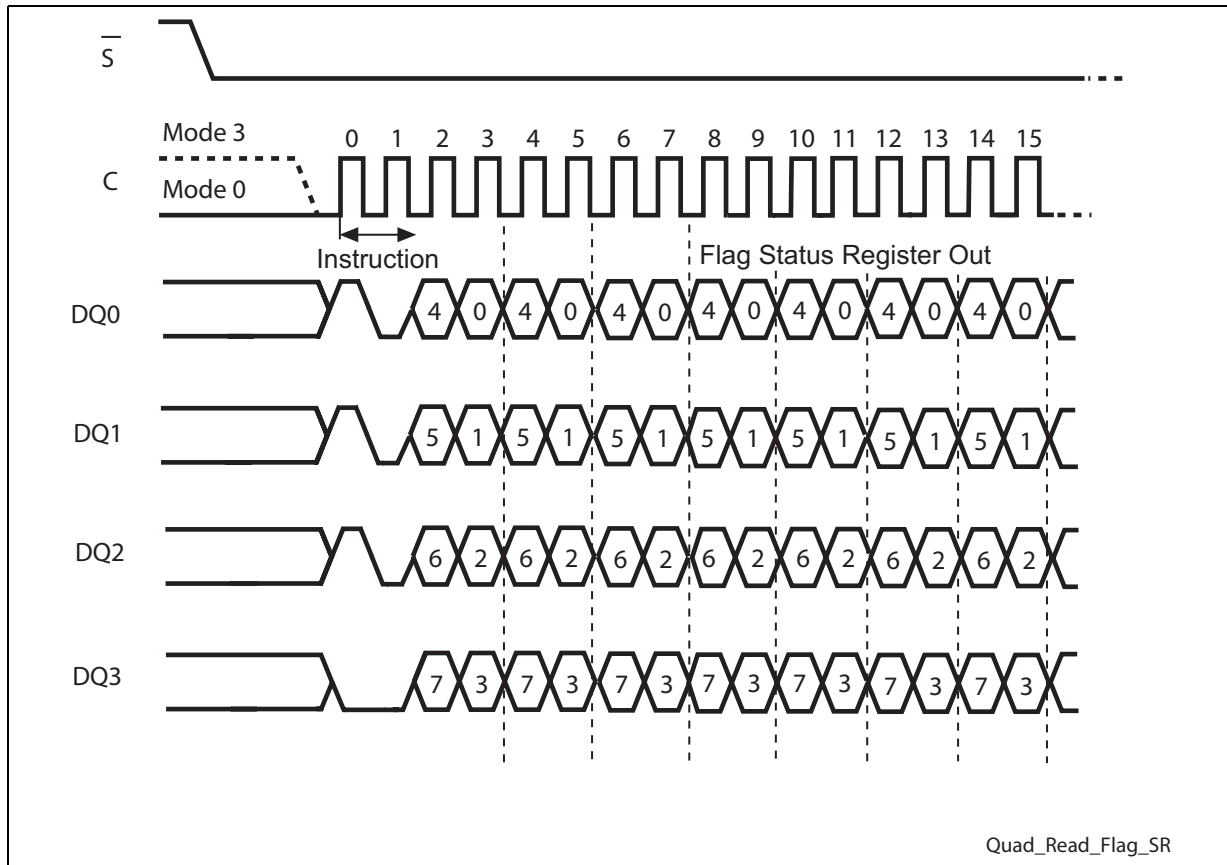

9.3.18 Clear Flag Status Register

The Clear Flag Status Register (CLFSR) instruction reset the error Flag Status Register bits (Erase Error bit, Program Error bit, VPP Error bit, Protection Error bit). It is not necessary to set the WEL bit before the Clear Flag Status Register instruction is executed. The WEL bit will be unchanged after this command is executed.

Figure 93. Clear Flag Status Register instruction sequence QIO-SPI

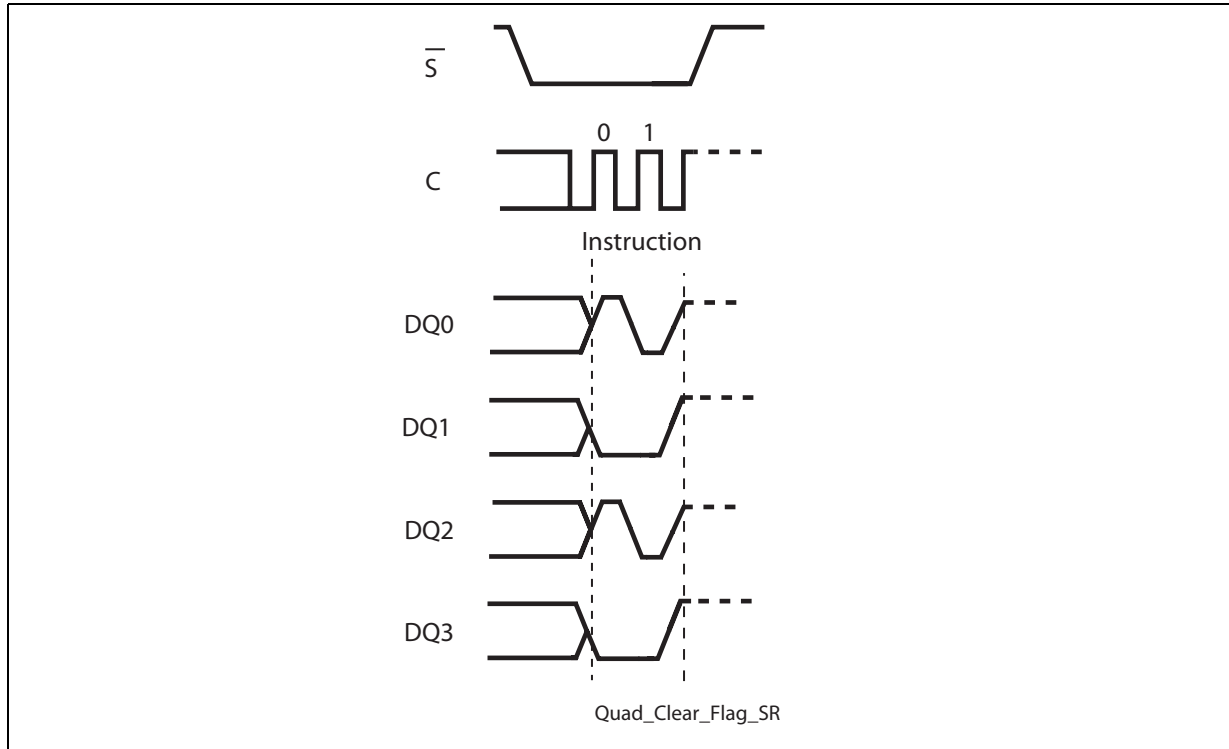

9.3.19 Read NV Configuration Register

The Read Non Volatile Configuration Register (RDNVCR) instruction allows the Non Volatile Configuration Register to be read.

Figure 94. Read NV Configuration Register instruction sequence QIO-SPI

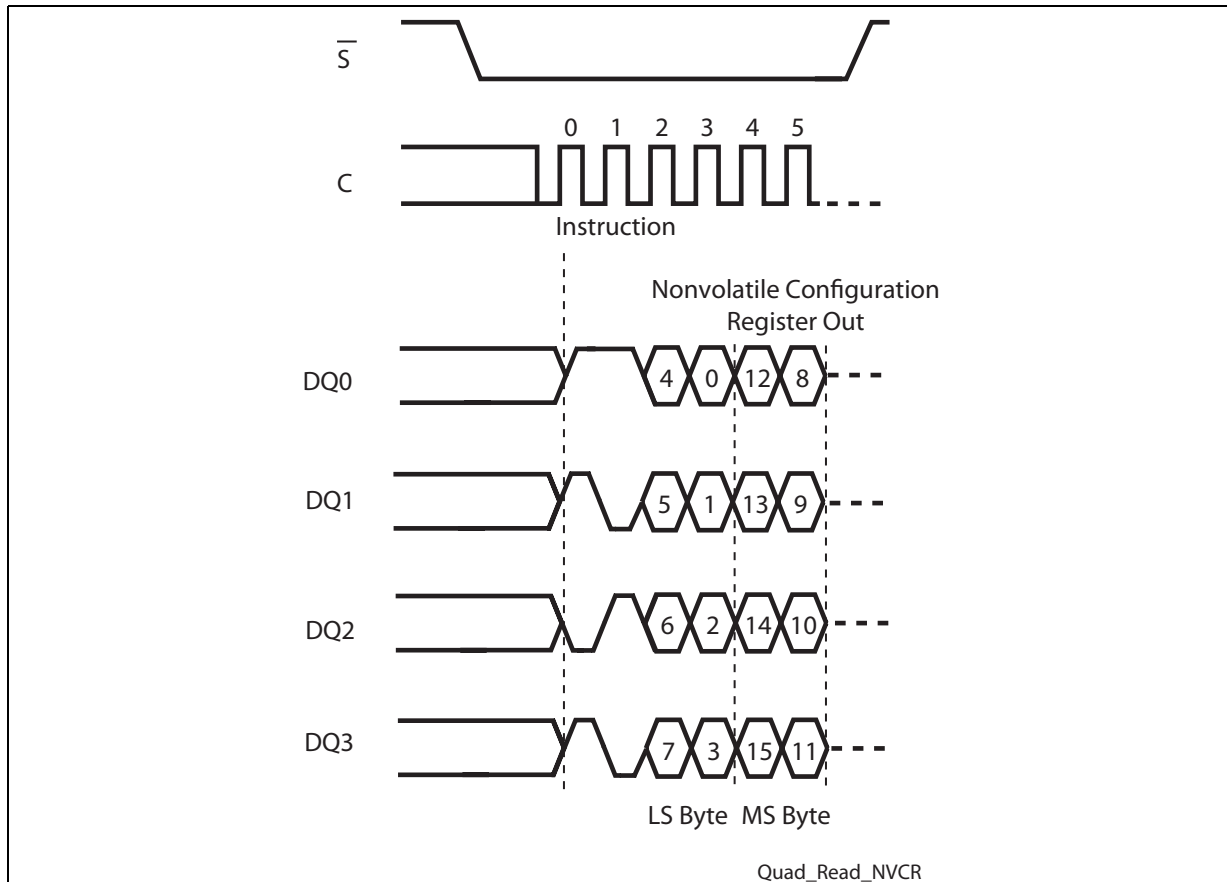

9.3.20 Write NV Configuration Register

The Write Non Volatile Configuration register (WRNVCR) instruction allows new values to be written to the Non Volatile Configuration register. Before it can be accepted, a write enable (WREN) instruction must previously have been executed.

Apart from the parallelizing of the instruction code and the input data on the four pins DQ0, DQ1, DQ2 and DQ3, the instruction functionality is exactly the same as the Write Non Volatile Configuration Register (WRNVCR) instruction of the Extended SPI protocol, please refer to [Section 9.1.29: Write NV Configuration Register](#) for further details.

Figure 95. Write NV Configuration Register instruction sequence QIO-SPI

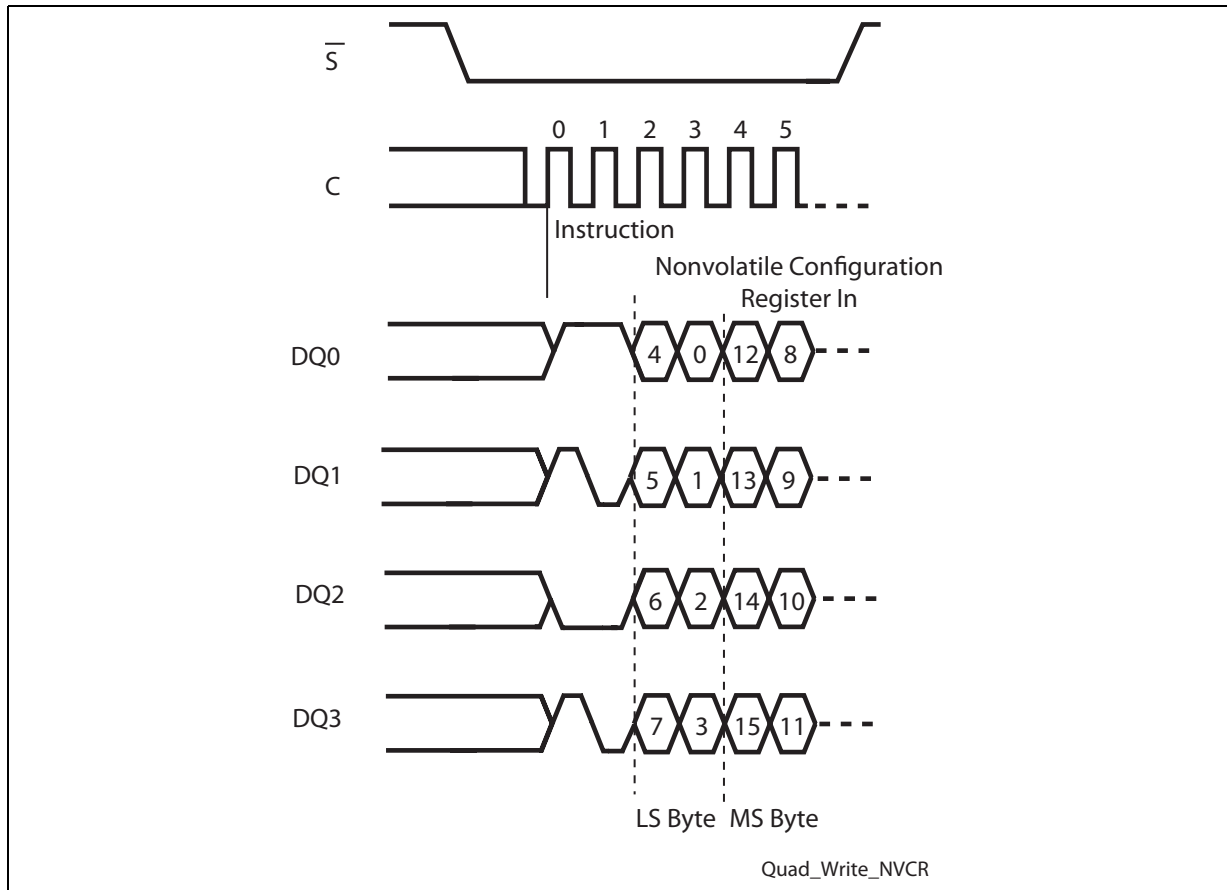

9.3.21 Read Volatile Configuration Register

The Read Volatile Configuration Register (RDVCR) instruction allows the Volatile Configuration Register to be read.

Figure 96. Read Volatile Configuration Register instruction sequence QIO-SPI

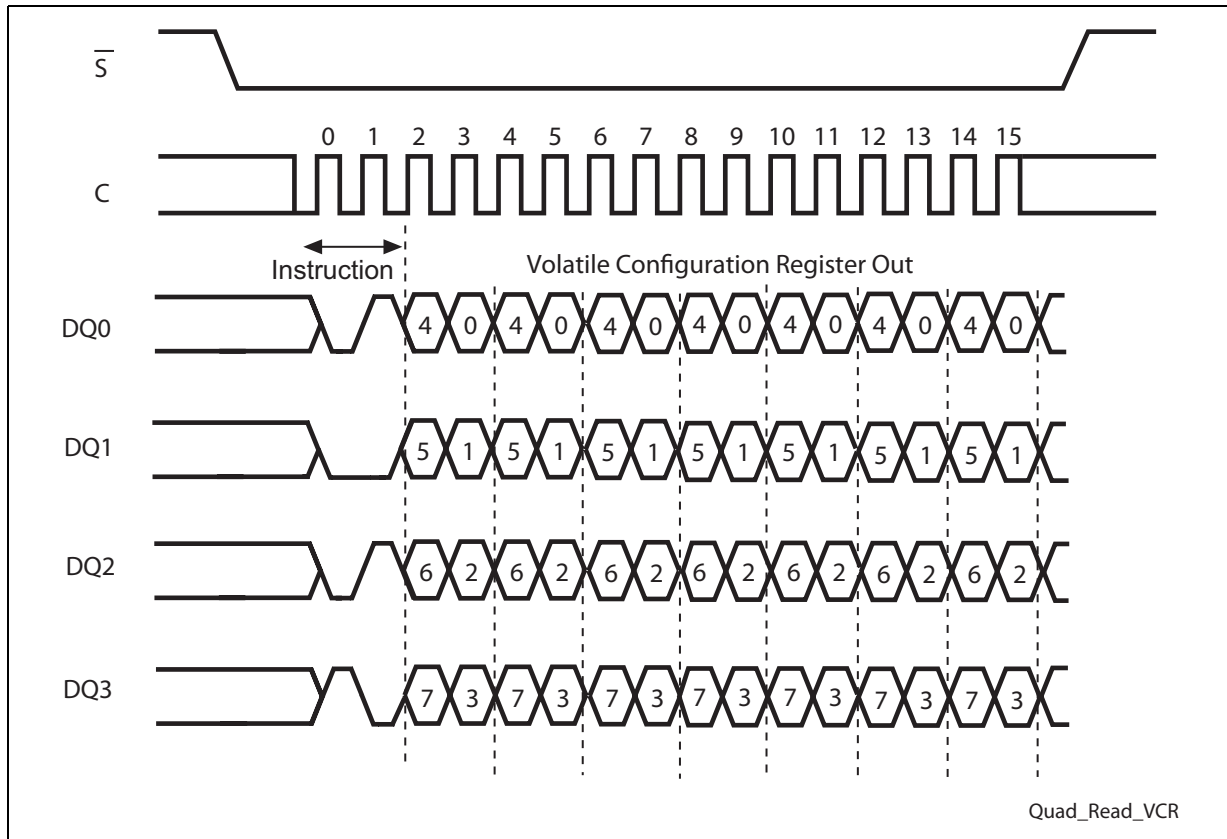

9.3.22 Write Volatile Configuration Register

The Write Volatile Configuration register (WRVCR) instruction allows new values to be written to the Volatile Configuration register. Before it can be accepted, a write enable (WREN) instruction must previously have been executed. In case of Fast POR, the WREN instruction is not required because a WREN instruction gets the device out from the Fast POR state (See [Section 11.1: Fast POR](#)).

Apart from the parallelizing of the instruction code and the input data on the four pins DQ0, DQ1, DQ2 and DQ3, the instruction functionality is exactly the same as the Write Volatile Configuration Register (WRVCR) instruction of the Extended SPI protocol, please refer to [Section 9.1.31: Write Volatile Configuration Register](#) for further details.

Figure 97. Write Volatile Configuration Register instruction sequence QIO-SPI

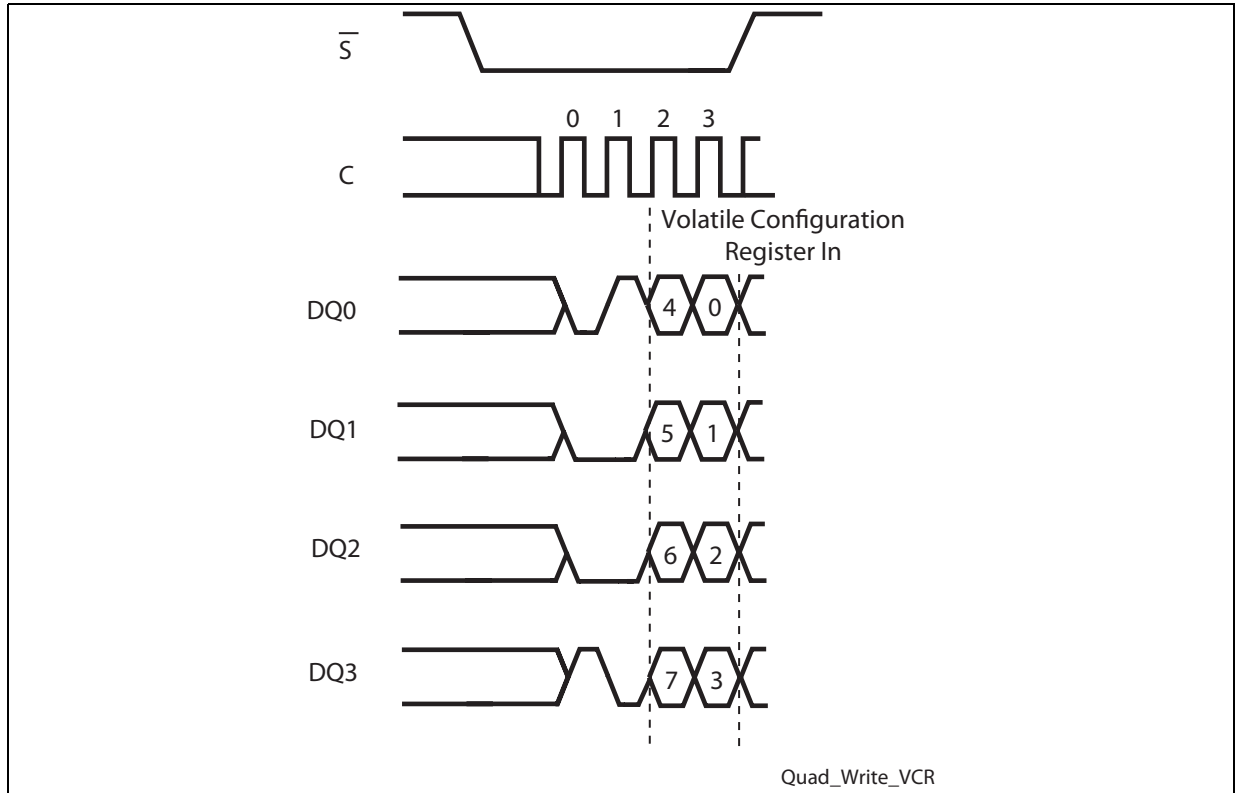

9.3.23 Read Volatile Enhanced Configuration Register

The Read Volatile Enhanced Configuration Register (RDVECR) instruction allows the Volatile Configuration Register to be read.

Figure 98. Read Volatile Enhanced Configuration Register instruction sequence QIO-SPI

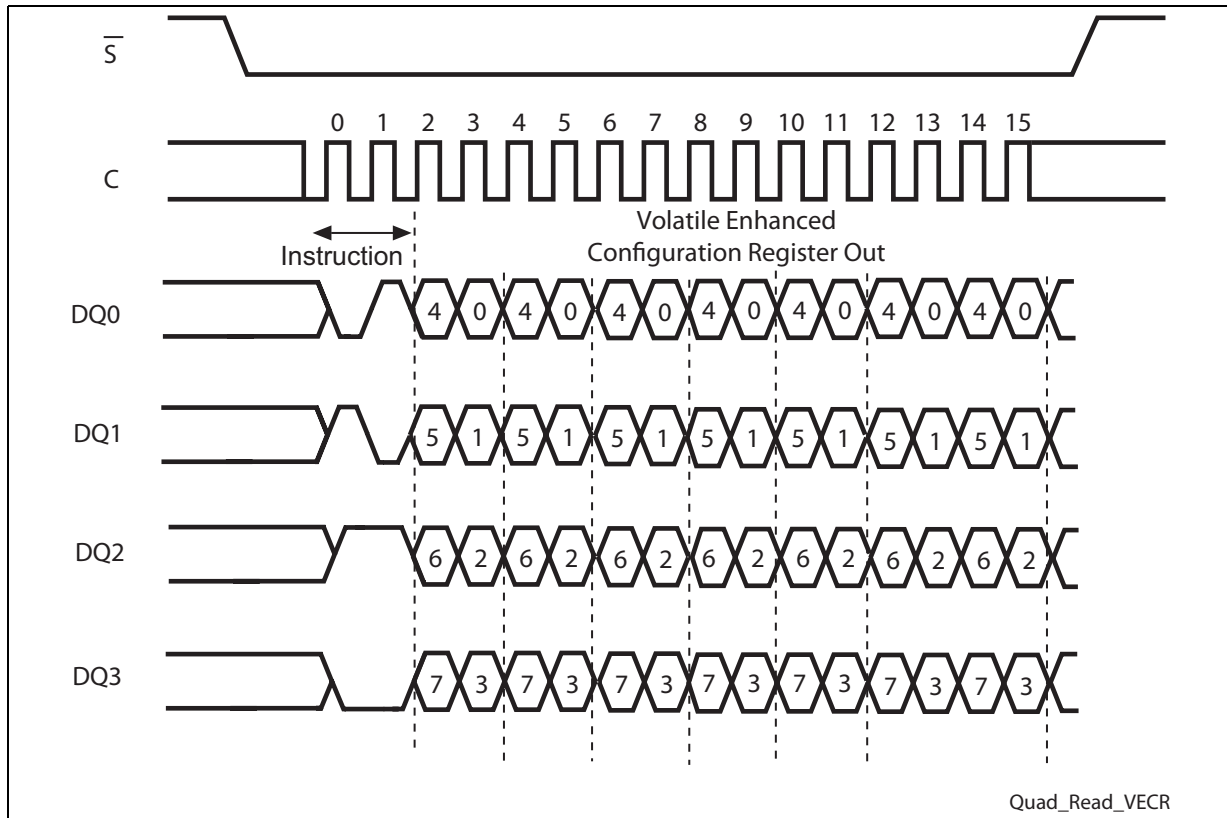

9.3.24 Write Volatile Enhanced Configuration Register

The Write Volatile Enhanced Configuration register (WRVECR) instruction allows new values to be written to the Volatile Enhanced Configuration register. Before it can be accepted, a write enable (WREN) instruction must previously have been executed. In case of Fast POR the WREN instruction is not required because a WREN instruction gets the device out from the Fast POR state (See [Section 11.1: Fast POR](#)).

Apart from the parallelizing of the instruction code and the input data on the four pins DQ0, DQ1, DQ2 and DQ3, the instruction functionality is exactly the same as the Write Volatile Enhanced Configuration Register (WRVECR) instruction of the Extended SPI protocol, please refer to [Section 9.1.33: Write Volatile Enhanced Configuration Register](#) for further details.

Figure 99. Write Volatile Enhanced Configuration Register instruction sequence QIO-SPI

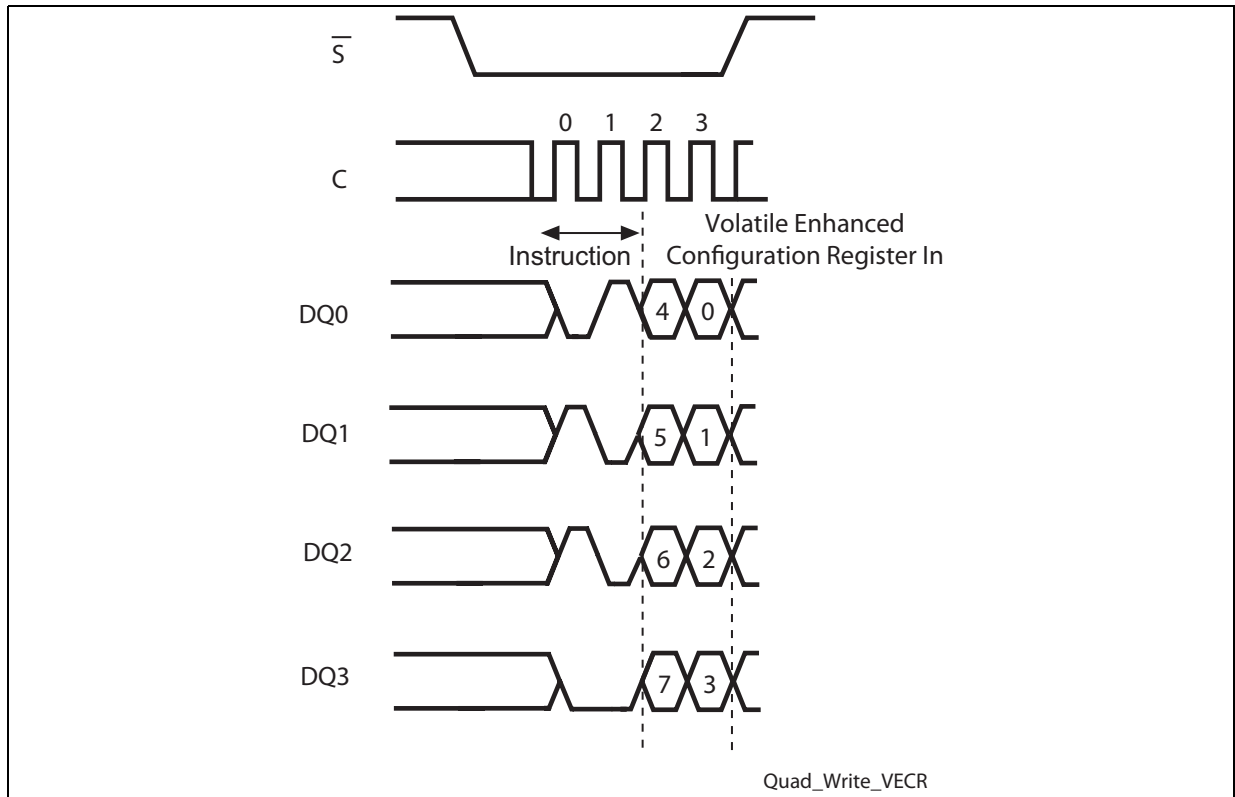

9.3.25 Deep Power-down (DP)

The Deep-Power-down (DP) instruction sets the device in Deep Power-down mode. Apart from the parallelizing of the instruction code on the four pins DQ0, DQ1, DQ2 and DQ3, the instruction functionality is exactly the same as the Deep Power-down (DP) instruction of the Extended SPI protocol. The instruction sequence is shown in [Figure 100](#).

Figure 100. Deep Power-down instruction sequence

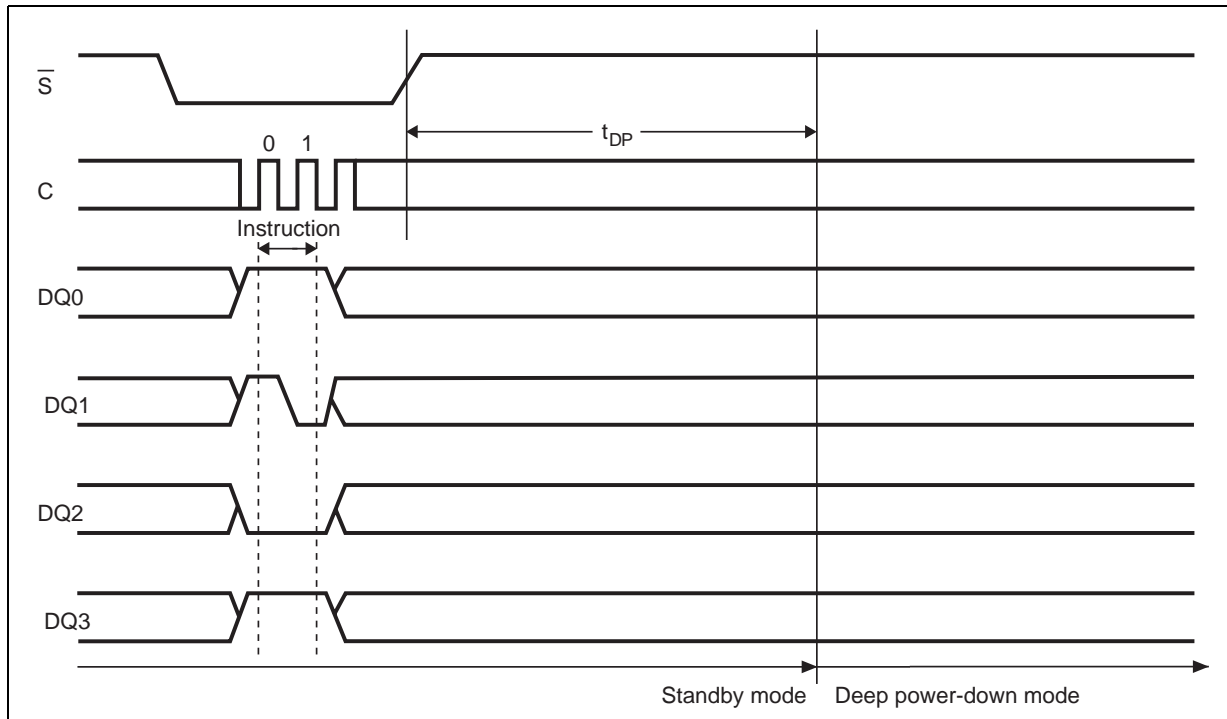

9.3.26 Release from Deep Power-down (RDP)

Once the device has entered the Deep Power-down mode, all instructions are ignored except the Release from Deep Power-down (RDP) instruction. Executing this instruction takes the device out of the Deep Power-down mode. Apart from the parallelizing of the instruction code on the two pins DQ0, DQ1, DQ2 and DQ3, the instruction functionality is exactly the same as the Release from Deep-Power-down (RDP) instruction of the Extended SPI protocol. The instruction sequence is shown in *Figure 101*.

Figure 101. Deep Power-down instruction sequence

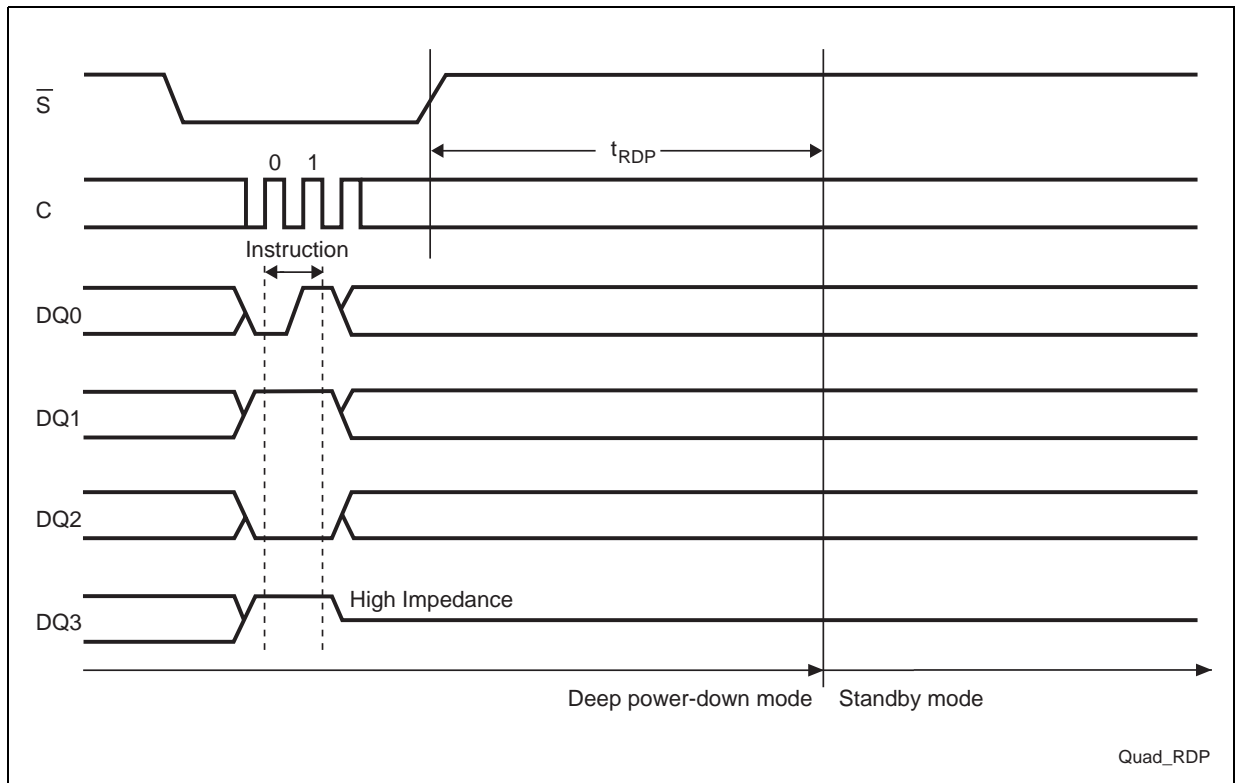

10 XIP Operations

XIP (eXecution in Place) mode is available in each protocol: Extended SPI, DIO-SPI, and QIO-SPI. XIP mode allows the memory to be read simply by sending an address to the device and then receiving the data on one, two, or four pins in parallel, depending on the customer requirements. It offers maximum flexibility to the application, saves instruction overhead, and allows a dramatic reduction to the Random Access time.

You can enable XIP mode in two ways:

- Using the Volatile Configuration Register: this is dedicated to applications that boot in SPI mode (Extended SPI, DIO-SPI or QIO-SPI) and then during the application life need to switch to XIP mode to directly execute some code in the flash.
- Using the Non Volatile Configuration Register: this is dedicated to applications that need to boot directly in XIP mode.

Setting to 0 the bit 3 of the Volatile Configuration Register the device is ready to enter in XIP mode right after the next fast read instruction (by 1, 2 or 4 pin).

While acting on the Non Volatile Configuration Register (bit 11 to bit 9, depending on which XIP type is required, single, dual or quad I/O) the memory enters in the selected XIP mode only after the next power-on sequence. The Non Volatile Configuration Register XIP configuration bits allows the memory to start directly in the required XIP mode (Single, Dual or Quad) after the power on.

The XIP mode status must be confirmed forcing the XIP confirmation bit to "0", the XIP confirmation bit is the value on the DQ0 pin during the first dummy clock cycle after the address in XIP reading instruction. Forcing the bit "1" on DQ0 during the first dummy clock cycle after the address (XIP Confirmation bit) the memory returns in the previous standard read mode, that means it will codify as an instruction code the next byte received on the input pin(s) after the next chip select. Instead, if the XIP mode is confirmed (by forcing the XIP confirmation bit to 0), after the device next de-selection and selection cycle, the memory codify the first 3 bytes received on the inputs pin(s) as a new address.

Besides not confirming the XIP mode during the first dummy clock cycle, it is possible to exit the XIP mode by mean of a dedicated rescue sequence.

Note: For devices with a feature set digit equal to 2 or 4 in the part number (Basic XiP), it is not necessary to set the Volatile Configuration Register bit 3 to enter XIP mode: it is possible to enter XIP mode directly by setting XIP Confirmation bit to 1 during the first dummy clock cycle after a fast read instruction. See [Section 16: Ordering information](#).

Figure 102. N25Q128 Read functionality Flow Chart

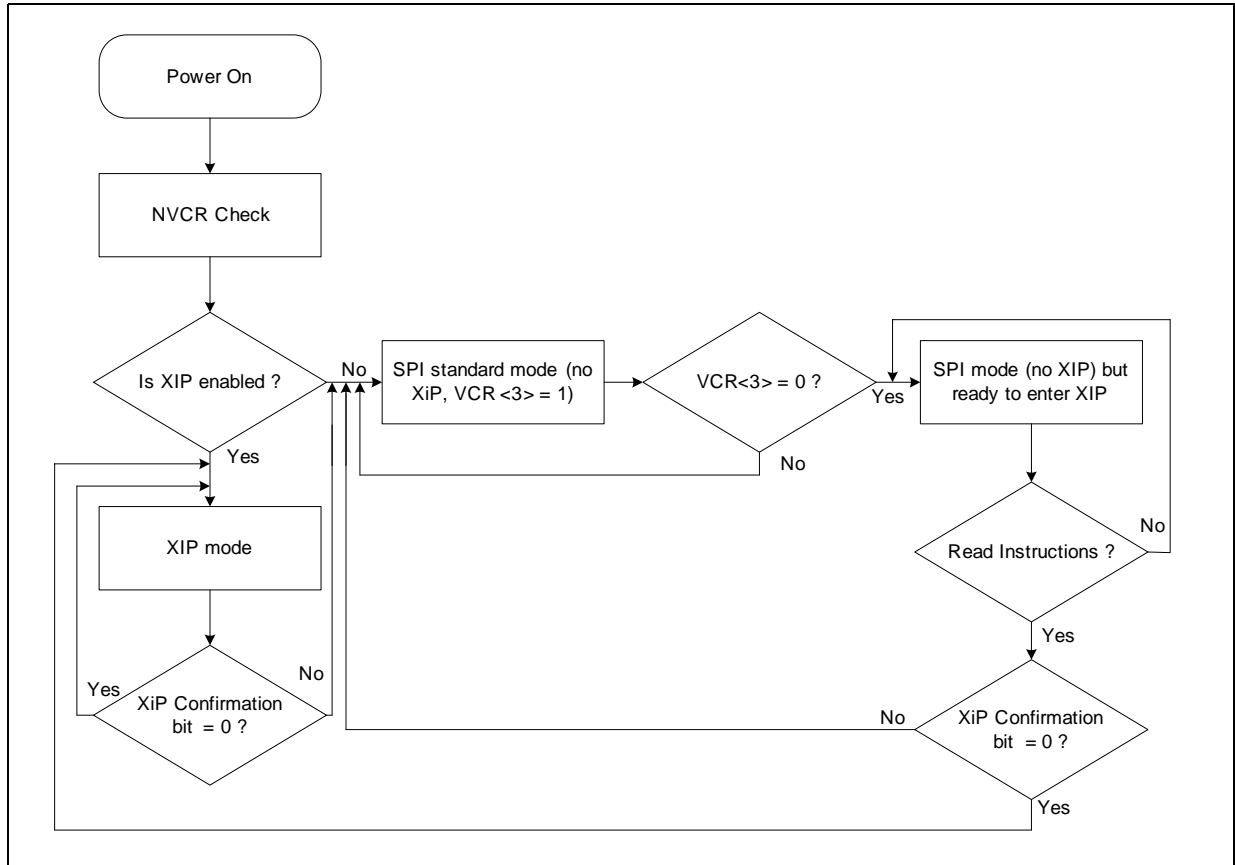

10.1 Enter XIP mode by setting the Non Volatile Configuration Register

To use the Non Volatile Configuration Register method to enter in XIP mode it is necessary to set the Non Volatile Configuration Register bits from 11 to 9 with the pattern corresponding to the required XIP mode by mean of the Write Non Volatile Configuration Register (WRNVCR) instruction. (See [Table 25.: NVCR XIP bits setting example.](#))

This instruction doesn't affect the XIP state until the next Power on sequence. In this case, after the next power on sequence, the memory directly accept addresses and then, after the dummy clock cycles (configurable), outputs the data as described in [Table 25.: NVCR XIP bits setting example.](#) For example to enable fast POR and XIP on QIOFR in normal SPI protocol with six dummy clock cycles the following pattern must be issued:

Table 25. NVCR XIP bits setting example

B1h (WRNVCR opcode)	+ 0110	100	111	0	1	11	xx
	6 dummy cycles for fast read instructions	XIP set as default; Quad I/O mode	Output Buffer driver strength default	FAST POR enabled	Hold/Reset not disabled	Extended SPI protocol	Don't Care

Figure 103. XIP mode directly after power on

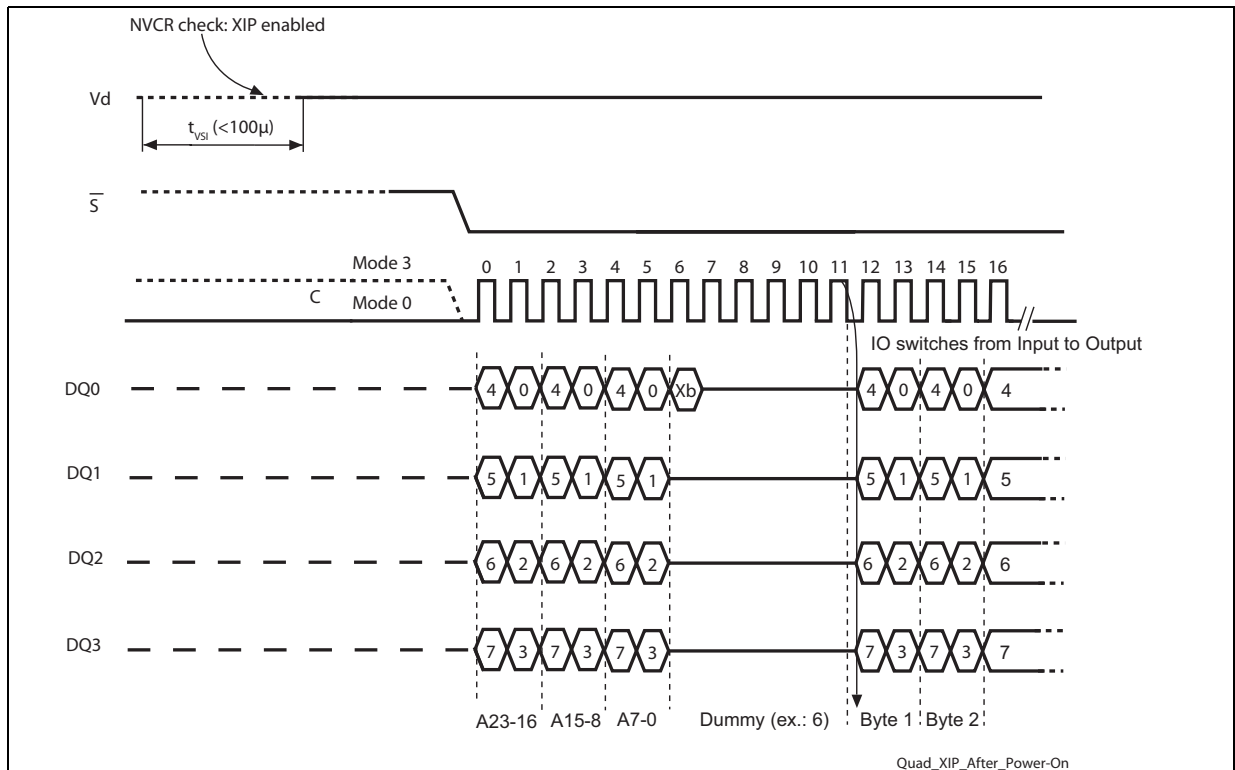

Note: Xb is the XIP Confirmation bit, and it should be set to '0' to keep XIP state or '1' to exit XIP mode and return to standard read mode.

10.2 Enter XIP mode by setting the Volatile Configuration Register

To use the Volatile Configuration Register method to enter XIP mode, it is necessary to write a 0 to bit 3 of the Volatile Configuration Register to make the device ready to enter XIP mode (2). This instruction doesn't permit to enter XIP state directly: a Fast Read instruction (either Single, Dual or Quad) is needed once to start the XIP Reading.

After the Fast Read instruction (Single, Dual or Quad) the XIP confirmation bit must be set to 0. (first bit on DQ0 during the first dummy cycle after the address has been received),

Then after the next de-select and select cycle (\bar{S} pin set to 1 and then to 0) the memory codify the first 3 bytes received on the input pin(s) directly as an address, without any instruction code, and after the dummy clock cycles (configurable) directly outputs the data.

For example to enable the XIP (without enter) with six dummy clock cycles, the pattern in [Table 26.: VCR XIP bits setting example](#) must be issued, and after that it is possible to enter, for example, in XIP mode from extended SPI read mode by mean of Quad Input Output Fast Read instruction, as described in [Table 26.: VCR XIP bits setting example](#).

Note: For devices with a feature set digit equal to 2 or 4 in the part number (Basic XiP), it is not necessary to set the Volatile Configuration Register bit 3 to enter in XIP mode: it is possible to enter directly in XIP mode by setting XIP Confirmation bit to 1 during the first dummy clock cycle after a fast read instruction. See [Section 16: Ordering information](#).

Table 26. VCR XIP bits setting example

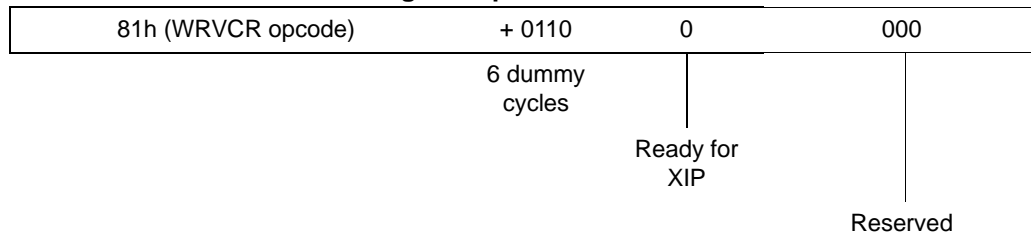
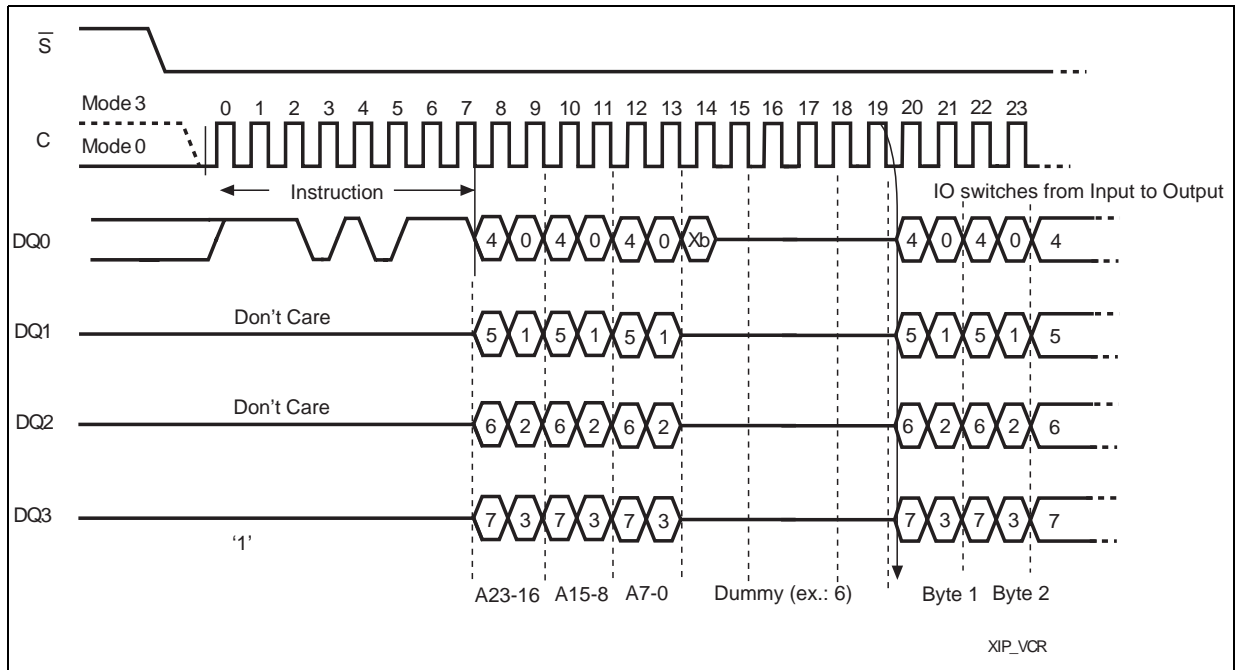

Figure 104. XiP: enter by VCR 2/2 (QIOFR in normal SPI protocol example)



Note: *Xb* is the XIP Confirmation bit, and it should be set to '0' to keep XIP state or '1' to exit XIP mode and return to standard read mode.

10.3 XIP mode hold and exit

The XIP mode does require at least one additional clock cycle to allow the XIP Confirmation bit to be sent to the memory on DQ0 during the first dummy clock cycle.

The device decodes the XIP Confirmation bit with the scheme:

- XIP Confirmation bit=0 means to hold XIP Mode
- XIP Confirmation bit=1 means to exit XIP Mode and comes back to read mode, that means codifying the first byte after the next chip select as an instruction code.

In Dual I/O XIP mode, the values of DQ1 during the first dummy clock cycle after the addresses is always Don't Care.

In Quad I/O XIP mode, the values of DQ3, DQ2 and DQ1 during the first dummy clock cycle after the addresses are always Don't Care.

In Dual and Single I/O XIP mode, in presence of the $\overline{\text{RESET}}$ pin enabled (in devices with a dedicated part number), a low pulse on that pin resets the XIP protocol as defined by the Volatile Configuration Register, reporting the memory at the state of last power up, as defined by the Non Volatile Configuration Register. In Quad I/O XiP modes, it is possible to reset the memory (for devices with a dedicated part number) only when the device is deselected. See [Section 16: Ordering information](#).

10.4 XIP Memory reset after a controller reset

If during the application life the system controller is reset during operation, and the device features the RESET functionality (in devices with a dedicated part number), and the feature has not been disabled, after the controller resets, the memory returns to POR state and there is no issue. See [Section 16: Ordering information](#).

In all the other cases, it is possible to exit the memory from the XIP mode by sending the following rescue sequence at the first chip selection after a system reset:

DQ0= '1' for:

7 clock cycles within \overline{S} low (\overline{S} becomes high before 8th clock cycle)

+ 13 clock cycles within \overline{S} low (\overline{S} becomes high before 14th clock cycle)

+ 25 clock cycles within \overline{S} low (\overline{S} becomes high before 26th clock cycle)

The global effect is only to exit from XIP without any other reset.

11 Power-up and power-down

At power-up and power-down, the device must not be selected (that is Chip Select (\bar{S}) must follow the voltage applied on VCC) until VCC reaches the correct value:

- VCC(min) at power-up, and then for a further delay of tVSL
- VSS at power-down

A safe configuration is provided in [Section 3: SPI Modes](#).

To avoid data corruption and inadvertent write operations during power-up, a Power On Reset (POR) circuit is included. The logic inside the device is held reset while VCC is less than the Power On Reset (POR) threshold voltage, VWI - all operations are disabled, and the device does not respond to any instruction.

Moreover, the device ignores the Write Enable (WREN) instruction and all the modify instructions until a time delay of tPUW has elapsed after the moment that VCC rises above the VWI threshold. However, the correct operation of the device is not guaranteed if, by this time, VCC is still below VCC(min). No Write Status Register, Program or Erase instructions should be sent until the later of:

- tPUW after VCC has passed the VWI threshold
- tVSL after VCC has passed the VCC(min) level

These values are specified in [Table 27.: Power-up timing and VWI threshold](#).

If the time, tVSL, has elapsed, after VCC rises above VCC(min), the device can be selected for READ instructions even if the tPUW delay has not yet fully elapsed.

After power-up, the device is in the following state:

- The device is in the Standby Power mode (not the Deep Power-down mode)
- The Write Enable Latch (WEL) bit is reset
- The Write In Progress (WIP) bit is reset
- The Lock Registers are configured as: (Write Lock bit, Lock Down bit) = (0,0).

Normal precautions must be taken for supply line decoupling, to stabilize the VCC supply.

Each device in a system should have the VCC line decoupled by a suitable capacitor close to the package pins (generally, this capacitor is of the order of 100 nF).

At power-down, when VCC drops from the operating voltage, to below the Power On Reset (POR) threshold voltage, VWI, all operations are disabled and the device does not respond to any instruction (the designer needs to be aware that if power-down occurs while a Write, Program or Erase cycle is in progress, some data corruption may result).

VPPH must be applied only when VCC is stable and in the VCC(min) to VCC(max) voltage range.

Figure 105. Power-up timing, Fast POR selected

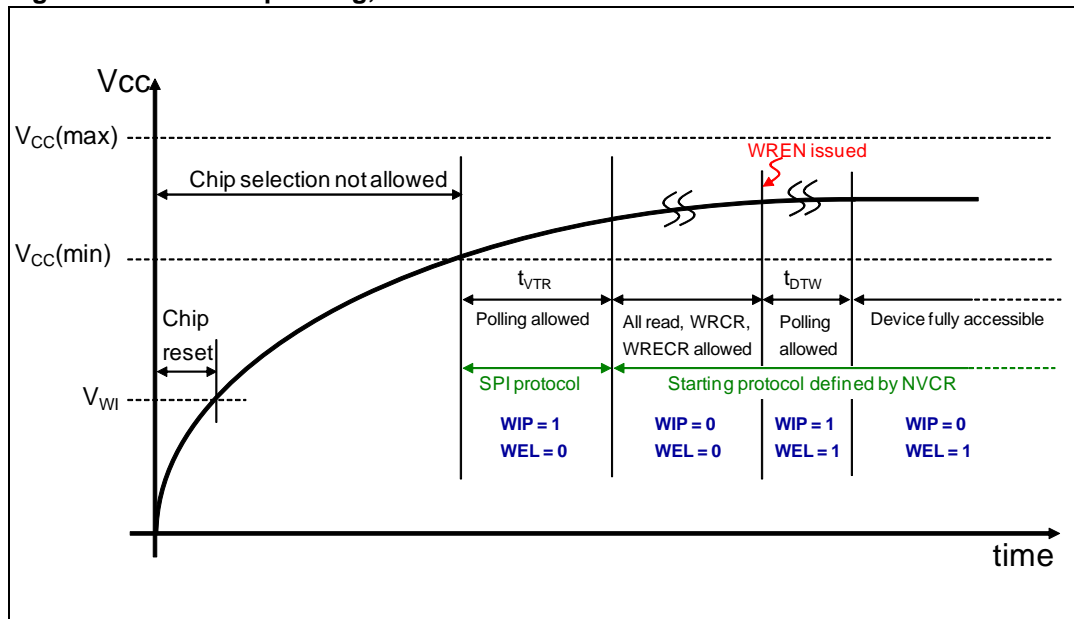

Figure 106. Power-up timing, Fast POR not selected

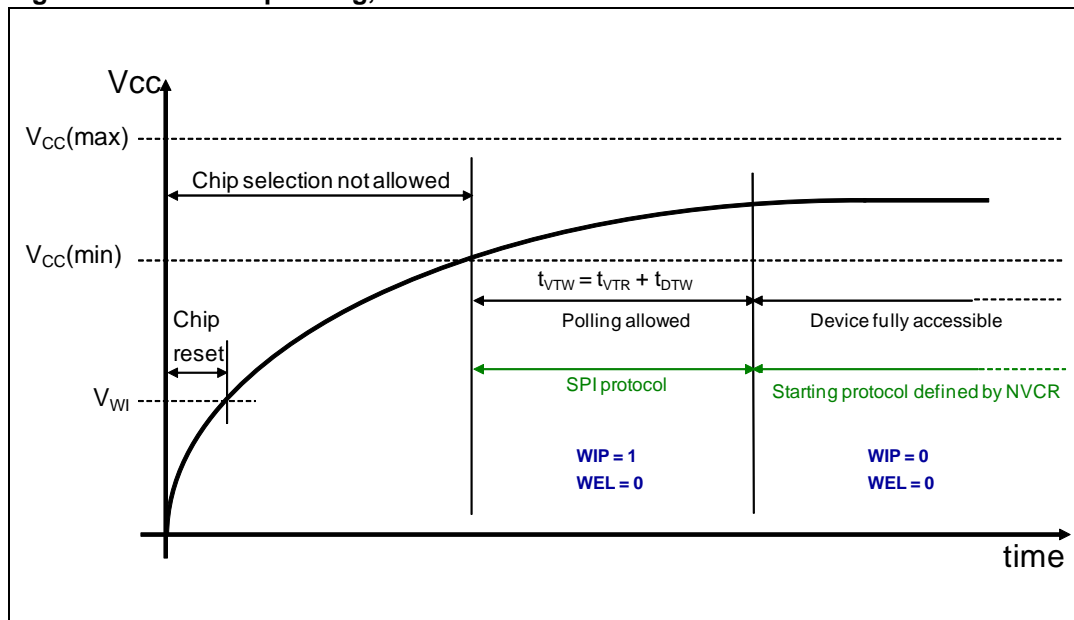

Table 27. Power-up timing and V_{WI} threshold

Symbol	Parameter	Min	Max	Unit
$t_{VTR}^{(1)}$	$V_{CC}(\text{min})$ to Read when Fast POR is selected		100	μs
$t_{DTW}^{(1)}$	Time delay to write instruction when Fast POR is selected		500	μs
$t_{VTW}^{(1)}$	$V_{CC}(\text{min})$ to device fully accessible		600	μs
$V_{WI}^{(1)}$	Write inhibit voltage	1.5	2.5	V

1. These parameters are characterized only.

11.1 Fast POR

The Fast POR feature is available to speed up the power-on sequence for applications that only require reading the memory after the power on sequence (no modify instructions).

If enabled, the Fast POR allows read operations and Volatile Configuration Register and Volatile Enhanced Configuration Register modifications after less than 100us, providing a substantially faster application boot phase.

In any case, even if the Fast POR sequence is selected, it is still possible to execute a modify instruction (erase or program) issuing a WREN instruction. In this case the device will have a latency time (~500us) after the first WREN instruction to complete POR sequence. During this latency time, when the power on second phase is running, no instruction will be accepted except for the polling instruction. During the power on second phase, both WEL & WIP bits are set to 1. At the end of POR sequence only the WEL bit is still set to 1.

To select or deselect the Fast POR feature, a Write non Volatile Configuration Register (WRNVCR) instruction is needed to properly set the dedicated bit (bit 5) of the Non Volatile Configuration Register.

11.2 Rescue sequence in case of power loss during WRNVCR

If a power loss occurs during a Write Non Volatile Configuration Register instruction, after the next power on the device could eventually wake up in a not determined state, for example a not required protocol or XIP mode. In that case a particular rescue sequence must be used to recover the device at a fixed state (Extended SPI protocol without XIP) until the next power up. Then to fix the problem definitively is recommended to run the Write Non Volatile configuration Register again.

The rescue sequence is composed of two parts that have to be run in the correct order. During all the sequence the TSHSL must be 50ns at least. The sequence is:

DQ0 (PAD DATA) equal to '1' for:

7 clock cycles within \overline{S} low (\overline{S} becomes high before 8th clock cycle)

+ 13 clock cycles within \overline{S} low (\overline{S} becomes high before 14th clock cycle)

+ 25 clock cycles within \overline{S} low (\overline{S} becomes high before 26th clock cycle)

To exit from XIP.

DQ0 (PAD DATA) and DQ3 (PAD HOLD) equal to '1' for:

8 clock cycles within \overline{S} low (\overline{S} becomes high before 9th clock cycle) to force Normal SPI protocol.

12 Initial delivery state

The device is delivered with the memory array erased: all bits are set to 1 (each byte contains FFh). The Status Register contains 00h (all Status Register bits are 0).

13 Maximum rating

Stressing the device outside the ratings listed here may cause permanent damage to the device. These are stress ratings only, and operation of the device at these, or any other conditions outside those indicated in the operating sections of this specification, is not implied. Exposure to absolute maximum rating conditions for extended periods may affect device reliability.

Table 28. Absolute maximum ratings

Symbol	Parameter	Min	Max	Unit
T _{STG}	Storage temperature	-65	150	°C
T _{LEAD}	Lead temperature during soldering		see ⁽¹⁾	°C
V _{IO}	Input and output voltage (with respect to ground)	-0.6	V _{CC} + 0.6	V
V _{CC}	Supply voltage	-0.6	4.0	V
V _{PP}	Fast program/erase voltage ⁽²⁾	-0.2	10.0	V
V _{ESD}	Electrostatic discharge voltage (human body model) ⁽³⁾	-2000	2000	V

1. Compliant with JEDEC Std. J-STD-020C (for small body, Sn-Pb or Pb assembly), the Numonyx ECOPACK® 7191395 specification, and the European directive on Restrictions on Hazardous Substances (RoHS) 2002/95/EU.

2. Avoid applying V_{PPH} to the \overline{W}/VPP pin during Bulk Erase.

3. JEDEC Std JESD22-A114A (C1 = 100 pF, R1 = 1500 Ω, R2 = 500 Ω).

14 DC and AC parameters

This section summarizes the operating and measurement conditions, and the DC and AC characteristics of the device. The parameters in the DC and AC characteristics tables that follow are derived from tests performed under the measurement conditions summarized in the relevant tables. Designers should check that the operating conditions in their circuit match the measurement conditions when relying on the quoted parameters.

Table 29. Operating conditions

Symbol	Parameter	Min	Typ	Max	Unit
V_{CC}	Supply voltage	1.7		2	V
V_{PPH}	Supply voltage on VPP	8.5		9.5	V
T_A	Ambient operating temperature	-40		85	°C

Table 30. AC measurement conditions

Symbol	Parameter	Min	Max	Unit
C_L	Load capacitance	30 ⁽¹⁾		pF
	Input rise and fall times		5	ns
	Input pulse voltages	0.2V _{CC} to 0.8V _{CC}		V
	Input timing reference voltages	0.3V _{CC} to 0.7V _{CC}		V
	Output timing reference voltages	V _{CC} / 2		V

1) Output Buffers are configurable by user.

Figure 107. AC measurement I/O waveform

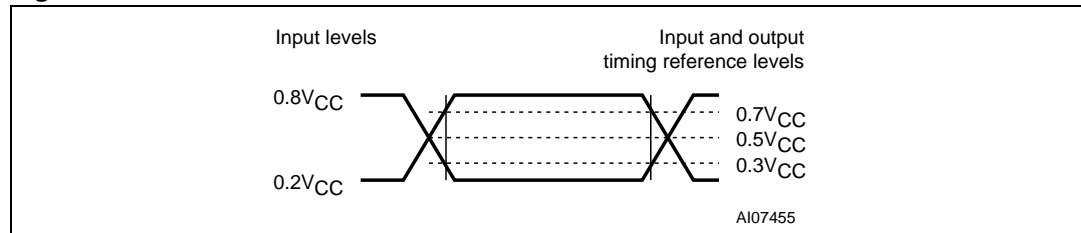

Table 31. Capacitance⁽¹⁾

Symbol	Parameter	Test condition	Min	Max	Unit
$C_{IN/OUT}$	Input/output capacitance (DQ0/DQ1/DQ2/DQ3)	$V_{OUT} = 0 V$		8	pF
C_{IN}	Input capacitance (other pins)	$V_{IN} = 0 V$		6	pF

1. Sampled only, not 100% tested, at $T_A=25\text{ °C}$ and a frequency of 54 MHz.

Table 32. DC Characteristics

Symbol	Parameter	Test condition (in addition to those in Table 29. : <i>Operating conditions</i>)	Min	Max	Unit
ILI	Input leakage current			± 2	μA
ILO	Output leakage current			± 2	μA
ICC1	Standby current	$\bar{S} = VCC, VIN = VSS$ or VCC		70	μA
ICC2	Deep Power-down current	$\bar{S} = VCC, VIN = VSS$ or VCC		10	μA
ICC3	Operating current (Fast Read Single I/O)	C = 0.1VCC / 0.9VCC at 108 MHz, DQ1 = open		15	mA
		C = 0.1VCC / 0.9VCC at 54 MHz, DQ1 = open		6	mA
	Operating current (Fast Read Dual I/O)	C = 0.1VCC / 0.9VCC at 108 MHz		18	mA
	Operating current (Fast Read Quad I/O)	C = 0.1VCC / 0.9VCC at 108 MHz		20	mA
ICC4	Operating current (Page Program Single, Dual and Quad I/O)	$\bar{S} = VCC$		20	mA
ICC5	Operating current (WRSR)	$\bar{S} = VCC$		20	mA
ICC6	Operating current (SE)	$\bar{S} = VCC$		20	mA
VIL	Input low voltage		- 0.5	0.3VCC	V
VIH	Input high voltage		0.7VCC	VCC+0.4	V
VOL	Output low voltage	IOL = 1.6 mA		0.4	V
VOH	Output high voltage	IOH = -100 μA	VCC-0.2		V

Note: The AC Characteristics data is preliminary.

Table 33. AC Characteristics (page 1 of 2)

Symbol	Alt.	Parameter	Min	Typ ⁽²⁾	Max	Unit
fC	fC	Clock frequency for the all the instructions (Extended SPI, DIO-SPI and QIO-SPI protocol) but the READ instruction	D.C.		108	MHz
fR		Clock frequency for read instructions	D.C.		54	MHz
tCH ⁽¹⁾	tCLH	Clock High time	4			ns
tCL ⁽²⁾	tCLL	Clock Low time	4			ns
tCLCH ⁽³⁾		Clock rise time ⁽⁴⁾ (peak to peak)	0.1			V/ns
tCHCL ⁽³⁾		Clock fall time ⁽⁴⁾ (peak to peak)	0.1			V/ns
tSLCH	tCSS	\bar{S} active setup time (relative to C)	4			ns
tCHSL			4			ns
tDVCH	tDSU	Data in setup time	2			ns
tCHDX	tDH	Data in hold time	3			ns
tCHSH		\bar{S} active hold time (relative to C)	4			ns
tSHCH		\bar{S} not active setup time (relative to C)	4			ns
tSHSL	tCSH	\bar{S} deselect time after a correct read instruction	20			ns
		\bar{S} deselect time after a not correct read or after any different instruction	50			ns
tSHQZ ⁽³⁾	tDIS	Output disable time			8	ns
tCLQV	tV	Clock Low to Output valid under 30 pF			7	ns
		Clock Low to Output valid under 10 pF			5	ns
tCLQX	tHO	Output hold time	1			ns
tHLCH		HOLD setup time (relative to C)	4			ns
tCHHH		HOLD hold time (relative to C)	4			ns
tHHCH		HOLD setup time (relative to C)	4			ns
tCHHL		HOLD hold time (relative to C)	4			ns
tHHQX ⁽³⁾	tLZ	HOLD to Output Low-Z			8	ns
tHLQZ ⁽³⁾	tHZ	HOLD to Output High-Z			8	ns
tWHSL ⁽⁵⁾		Write protect setup time	20			ns
tSHWL ⁽⁵⁾		Write protect hold time	100			ns

Table 33. AC Characteristics (page 2 of 2)

Symbol	Alt.	Parameter	Min	Typ ⁽²⁾	Max	Unit
tVPPHSL ⁽⁶⁾		Enhanced program supply voltage High (VPPH) to Chip Select Low for Single and Dual I/O Page Program	200			ns
tW		Write status register cycle time		1.3	8	ms
tCFSR		Clear flag status register cycle time		40		ns
tWNVCR		Write non volatile configuration register cycle time		0.2	3	s
tWVCR		Write volatile configuration register cycle time		40		ns
tWRVECR		Write volatile enhanced configuration register cycle time		40		ns
tPP ⁽⁷⁾		Page program cycle time (n bytes)		$\text{int}(n/8) \times 0.015^{(8)}$	5	ms
		Program OTP cycle time (64 bytes)		0.4		ms
tSSE		Subsector erase cycle time		0.2	2	s
tSE		Sector erase cycle time		0.7	3	s
tBE		Bulk erase cycle time		170	250	s

- tCH + tCL must be greater than or equal to 1/ fC.
- Typical values given for TA = 25 °C
- Value guaranteed by characterization, not 100% tested in production.
- Expressed as a slew-rate.
- Only applicable as a constraint for a WRSR instruction when SRWD is set to '1'.
- VPPH should be kept at a valid level until the program or erase operation has completed and its result (success or failure) is known. Avoid applying VPPH to the W/VPP pin during Bulk Erase.
- When using the page program (PP) instruction to program consecutive bytes, optimized timings are obtained with one sequence including all the bytes versus several sequences of only a few bytes (1 ≤ n ≤ 256).
- int(A) corresponds to the upper integer part of A. For example int(12/8) = 2, int(32/8) = 4 int(15.3) = 16.

Figure 108. Reset AC waveforms: program or erase cycle is in progress

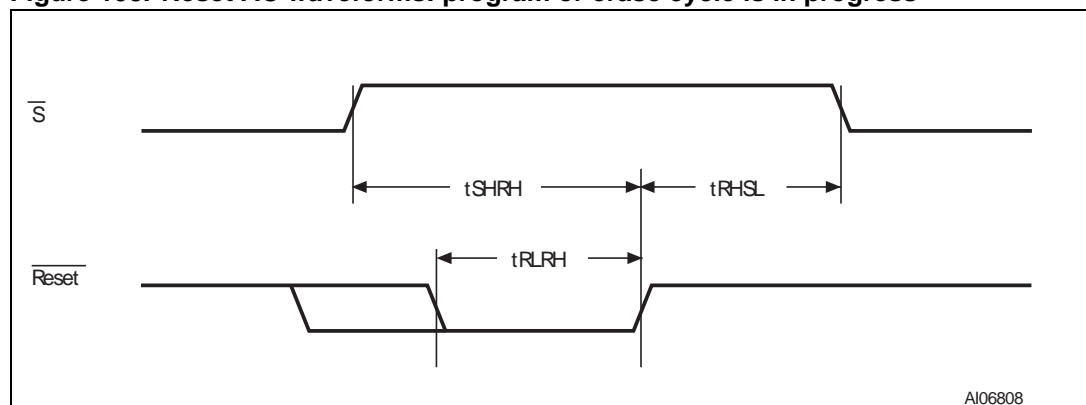

See [Table 34.: Reset Conditions](#).

Table 34. Reset Conditions

Symbol	Alt.	Parameter	Conditions	Min	Typ	Max	Unit
tRLRH ⁽¹⁾⁽²⁾	tRST	Reset pulse width		50			ns
tRHSL ⁽¹⁾	tREC	Reset Recovery Time	Device selected (\bar{S} low), while decoding any modify instruction, during all read operations, CLFSR, WRDI, WREN, WRLR, WRVCR, WRVECR.	40			ns
			Under completion of an internal erase or program cycle related to POTP, PP, DIEFP, DIFP, QIEFP, QIFP, SE, BE, PER, PES.	30			μ s
			Under completion of an SSE operation.		t _{SSE}		ms
			Under completion of an WRSR operation.		t _W		ms
			Under completion of an WRNVCR operation.		t _{WNVCR}		ms
			Under completion of the first WREN issued when Fast POR selected.		t _{DTW}		μ s
			Device deselected (\bar{S} high) and in XiP mode.	40			ns
Device deselected (\bar{S} high) and in Standby mode.	40			ns			
tSHRV ⁽¹⁾		S# deselect to R valid	Deselect to R valid in Quad Output or in QIO-SPI.	2			ns
tDP			S High to Deep Power Down mode	3			μ s
tRDP			S High to Standby mode	30			μ s

1. All values are guaranteed by characterization and not 100% tested in production.
2. The device reset is possible but not guaranteed if tRLRH < 50 ns.

Figure 109. Serial input timing

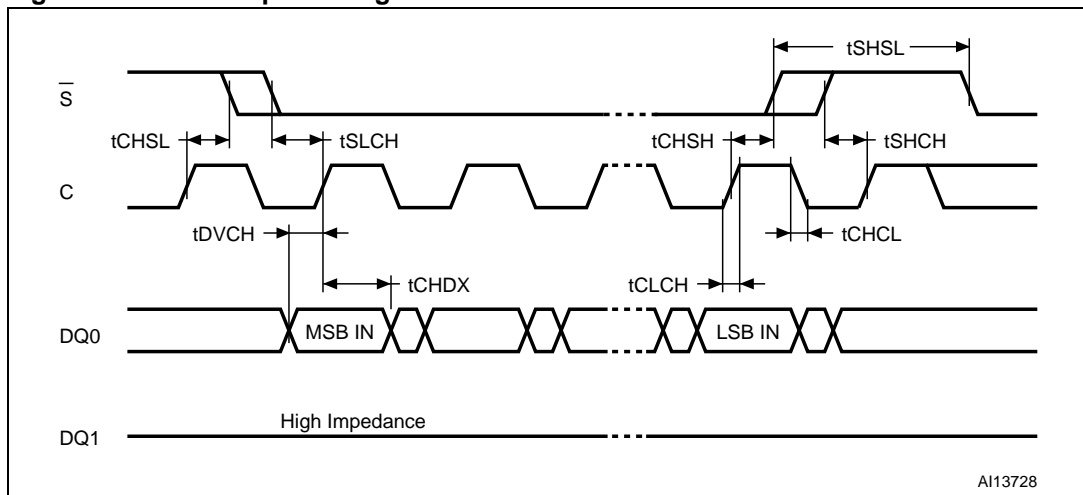

Figure 110. Write protect setup and hold timing during WRSR when SRWD=1

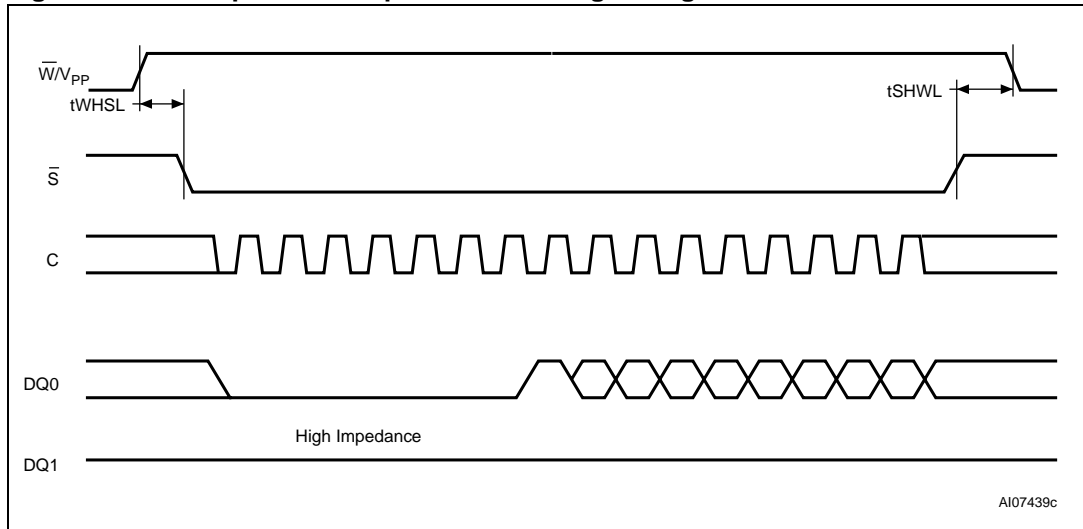

Figure 111. Hold timing

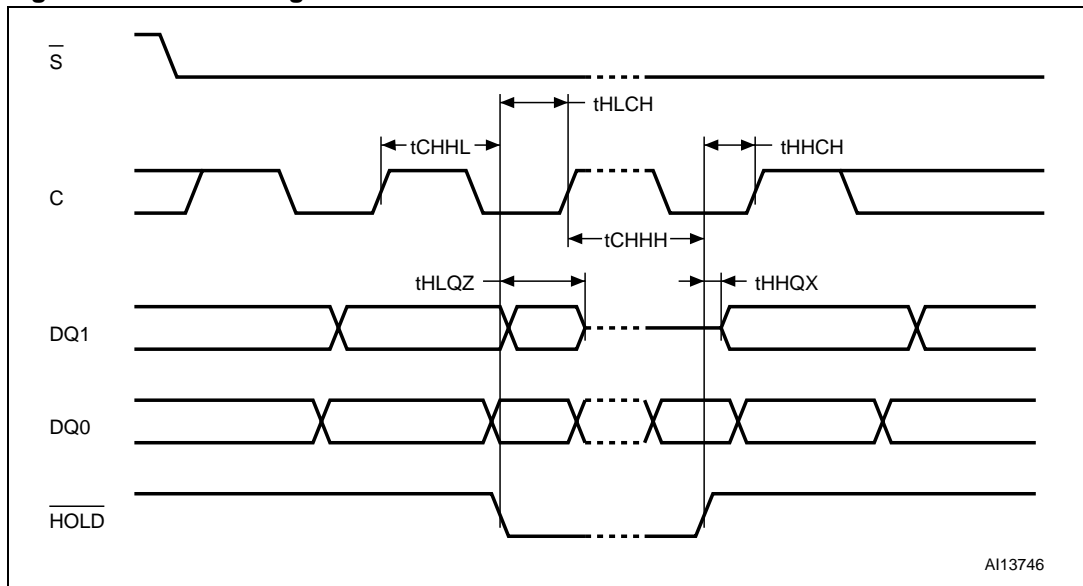
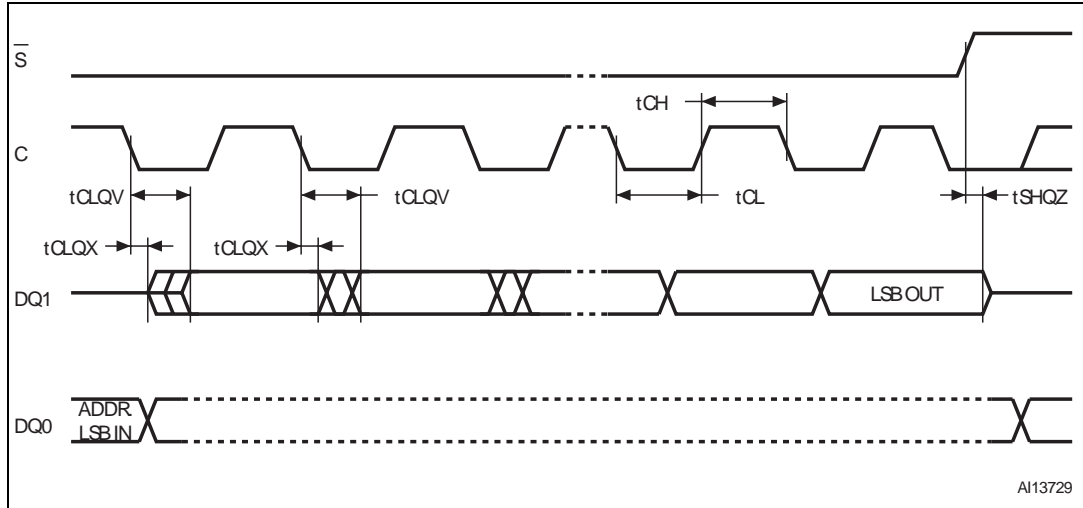
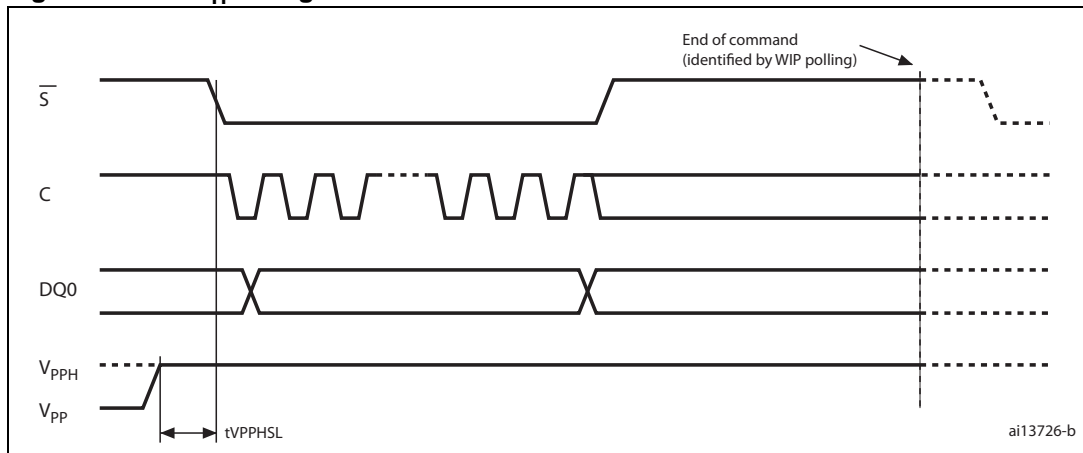

Figure 112. Output timing



AI13729

Figure 113. V_{PPH} timing



ai13726-b

15 Package mechanical

In order to meet environmental requirements, Numonyx offers these devices in RoHS compliant packages. These packages have a lead-free second level interconnect. The category of second level interconnect is marked on the package and on the inner box label, in compliance with JEDEC Standard JESD97. The maximum ratings related to soldering conditions are also marked on the inner box label.

Figure 114. VDFPN8 (MLP8) 8-lead very thin dual flat package no lead, 8 × 6 mm, package outline

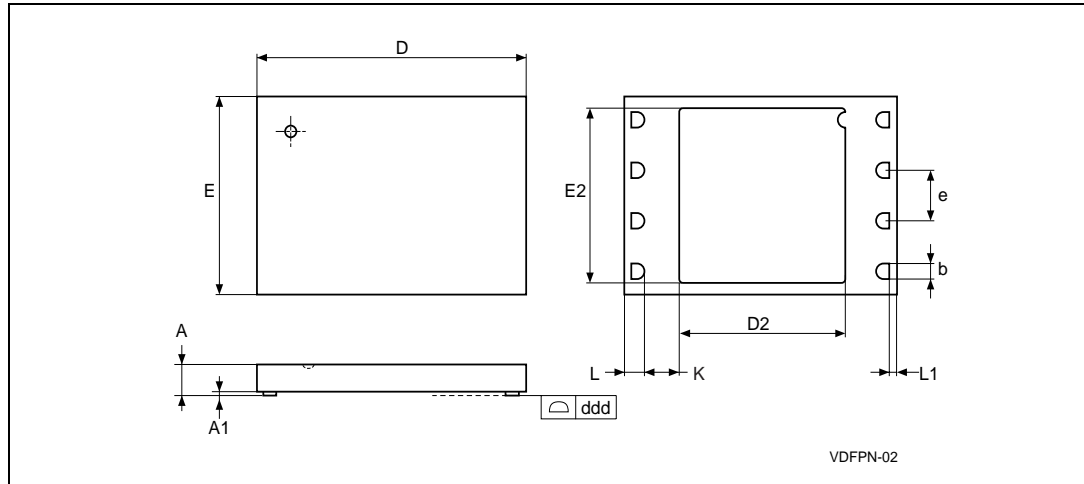

1. Drawing is not to scale.
2. The circle in the top view of the package indicates the position of pin 1.

Table 35. VDFPN8 (MLP8) 8-lead very thin dual flat package no lead, 8 × 6 mm, package mechanical data

Symbol	Millimeters			Inches		
	Typ	Min	Max	Typ	Min	Max
A	0.85		1.00	0.033		0.039
A1		0.00	0.05		0.000	0.002
b	0.40	0.35	0.48	0.016	0.014	0.019
D	8.00			0.315		
D2	5.16		(1)	0.203		
ddd			0.05			0.002
E	6.00			0.236		
E2	4.80			0.189		
e	1.27	–	–	0.050	–	–
K		0.82			0.032	
L	0.50	0.45	0.60	0.020	0.018	0.024
L1			0.15			0.006
N	8			8		

1. D2 Max must not exceed (D – K – 2 × L).

Figure 115. SO16 wide - 16-lead plastic small outline, 300 mils body width, package outline

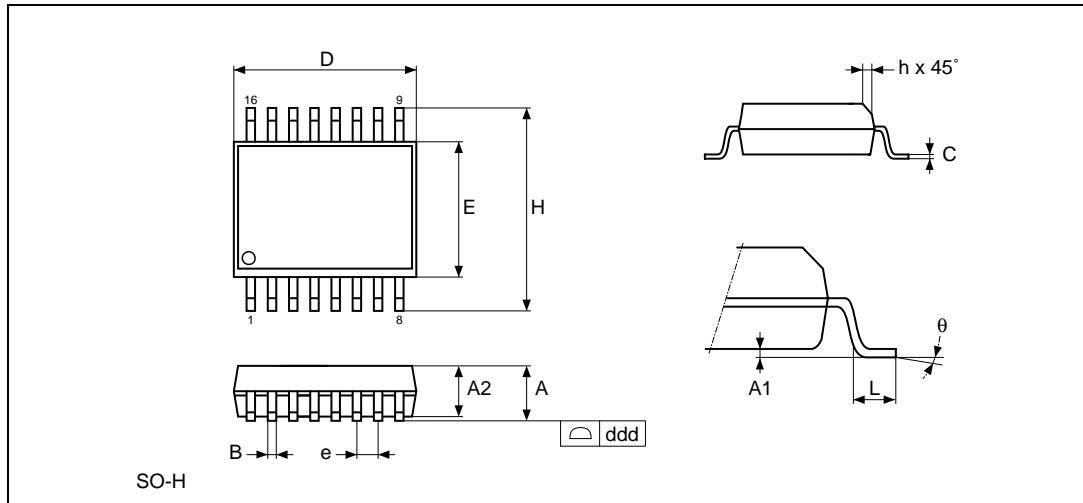

1. Drawing is not to scale.

Table 36. SO16 wide - 16-lead plastic small outline, 300 mils body width, mechanical data

Symbol	Millimeters			Inches		
	Typ	Min	Max	Typ	Min	Max
A		2.35	2.65		0.093	0.104
A1		0.10	0.30		0.004	0.012
B		0.33	0.51		0.013	0.020
C		0.23	0.32		0.009	0.013
D		10.10	10.50		0.398	0.413
E		7.40	7.60		0.291	0.299
e	1.27	–	–	0.050	–	–
H		10.00	10.65		0.394	0.419
h		0.25	0.75		0.010	0.030
L		0.40	1.27		0.016	0.050
θ		0°	8°		0°	8°
ddd			0.10			0.004

Figure 116. TBGA - 6 x 8 mm, 24-ball, mechanical package outline

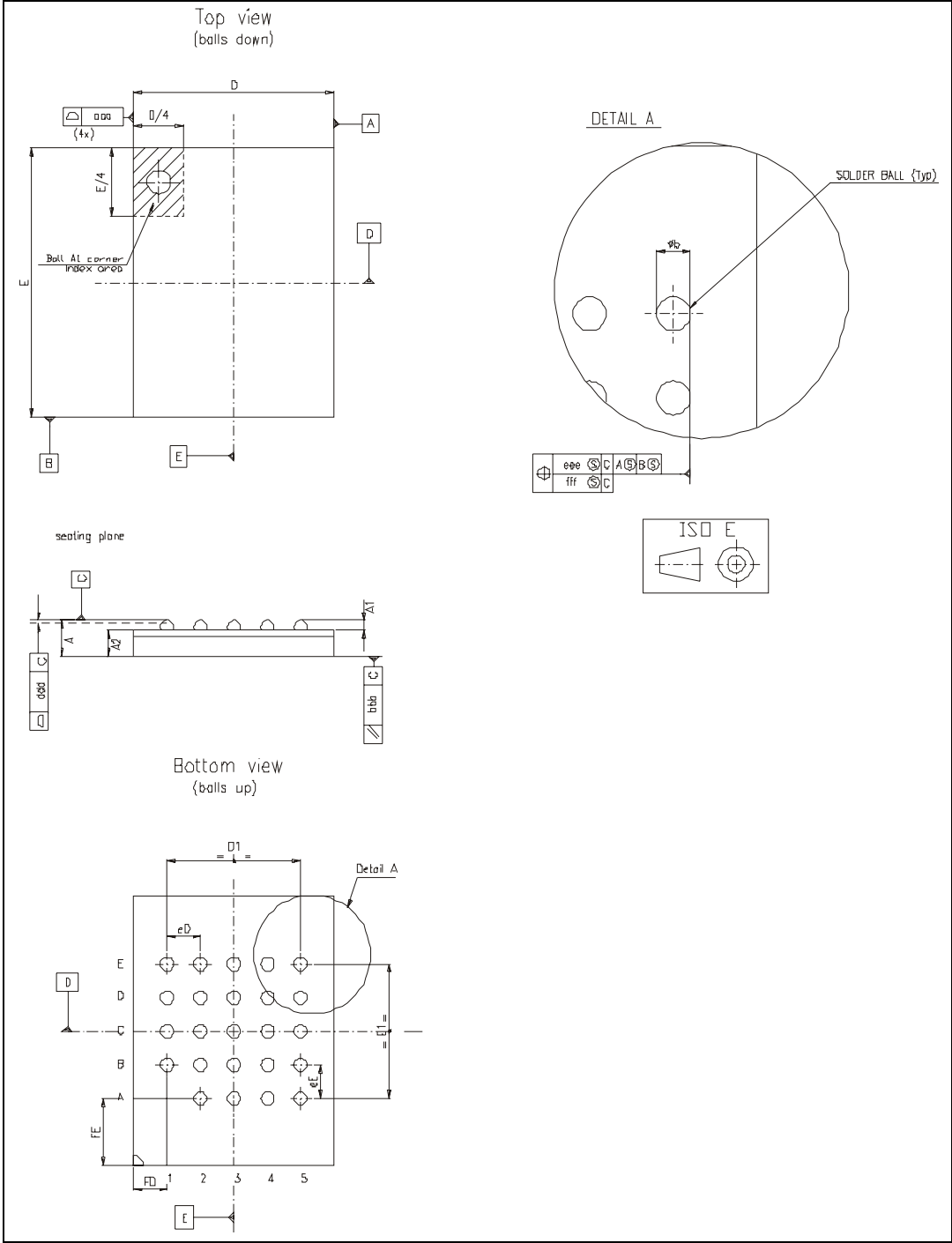

1. Drawing is not to scale.

Table 37. TBGA 6x8 mm 24-ball package dimensions

	MIN	NOM	MAX
A			1.20
A1	0.20		
A2		0.79	
Øb	0.35	0.40	0.45
D	5.90	6.00	6.10
D1		4.00	
E	7.90	8.00	8.10
E1		4.00	
eD		1.00	
eE		1.00	
FD		1.00	
FE		2.00	
MD	5		
ME	5		
n	24 balls		
aaa			0.15
bbb			0.10
ddd			0.10
eee			0.15
fff			0.08
Control unit: mm			

16 Ordering information

Note: For further information on line items not listed here or on any aspect of this device, please contact your nearest Numonyx Sales Office.

Table 38. Ordering information scheme

Example:	N25Q128	A	1	1	B	F8	4	0	E
Device type									
N25Q = serial Flash memory, Quad I/O, XiP									
Device density									
128 = 128 Mbit									
Technology									
A = 65 nm									
Feature set									
1 = Byte addressability, Hold pin, Numonyx XiP									
2 = Byte addressability, Hold pin, Basic XiP									
3 = Byte addressability, Reset pin, Numonyx XiP									
4 = Byte addressability, Reset pin, Basic XiP									
Operating voltage									
1 = VCC = 1.7 V to 2 V									
Block Structure									
B = Bottom									
T = Top									
E = Uniform (no boot sectors)									
Package									
F8 = VDFPN8 8 x 6 mm (MLP8) (RoHS compliant)									
SF = SO16 (300 mils width) (RoHS compliant)									
12 = TBGA24 6 x 8 mm (RoHS compliant)									
Temperature and test flow									
4 = Industrial temperature range, -40 to 85 °C									
Device tested with standard test flow									
A = Automotive temperature range, -40 to 125 °C									
Device tested with high reliability certified test flow									
H = Industrial temperature range, -40 to 85 °C									
Device tested with high reliability certified test flow									
Security features ⁽¹⁾									
0 = No extra security									
Packing options									
E = Tray packing									
F = Tape and reel packing									
G = Tube packing									

1. Additional secure options are available upon customer request.

Table 39. Valid Order Information Line Items

Part Number	Features	Block Structure	Package	Temperature and Test Flow	Security
N25Q128A11BF840E N25Q128A11BF840F	Byte addressability, Hold pin, Numonyx XiP	Bottom	VDFPN8 8x6 mm	Industrial temp; Standard test flow	No extra security
N25Q128A21BF840E N25Q128A21BF840F	Byte addressability, Hold pin, Basic XiP	Bottom	VDFPN8 8x6 mm	Industrial temp; Standard test flow	No extra security
N25Q128A11TF840E N25Q128A11TF840F	Byte addressability, Hold pin, Numonyx XiP	Top	VDFPN8 8x6 mm	Industrial temp; Standard test flow	No extra security
N25Q128A21TF840E N25Q128A21TF840F	Byte addressability, Hold pin, Basic XiP	Top	VDFPN8 8x6 mm	Industrial temp; Standard test flow	No extra security
N25Q128A11B1240E N25Q128A11B1240F	Byte addressability, Hold pin, Numonyx XiP	Bottom	TBGA24 6x8 mm	Industrial temp; Standard test flow	No extra security
N25Q128A21B1240E N25Q128A21B1240F	Byte addressability, Hold pin, Basic XiP	Bottom	TBGA24 6x8 mm	Industrial temp; Standard test flow	No extra security
N25Q128A11T1240E N25Q128A11T1240F	Byte addressability, Hold pin, Numonyx XiP	Top	TBGA24 6x8 mm	Industrial temp; Standard test flow	No extra security
N25Q128A21T1240E N25Q128A21T1240F	Byte addressability, Hold pin, Basic XiP	Top	TBGA24 6x8 mm	Industrial temp; Standard test flow	No extra security
N25Q128A11BSF40F N25Q128A11BSF40G	Byte addressability, Hold pin, Numonyx XiP	Bottom	SO16 (300 mils width)	Industrial temp; Standard test flow	No extra security
N25Q128A21BSF40F N25Q128A21BSF40G	Byte addressability, Hold pin, Basic XiP	Bottom	SO16 (300 mils width)	Industrial temp; Standard test flow	No extra security
N25Q128A11TSF40F N25Q128A11TSF40G	Byte addressability, Hold pin, Numonyx XiP	Top	SO16 (300 mils width)	Industrial temp; Standard test flow	No extra security
N25Q128A21TSF40F N25Q128A21TSF40G	Byte addressability, Hold pin, Basic XiP	Top	SO16 (300 mils width)	Industrial temp; Standard test flow	No extra security

Note: Packing information details: E= tray, F= tape-n-reel, G= tube (16th digit of part number).

17 Revision history

Table 40. Document revision history

Date	Revision	Changes
12-Feb-2010	1.0	Initial public release.

Please Read Carefully:

INFORMATION IN THIS DOCUMENT IS PROVIDED IN CONNECTION WITH NUMONYX™ PRODUCTS. NO LICENSE, EXPRESS OR IMPLIED, BY ESTOPPEL OR OTHERWISE, TO ANY INTELLECTUAL PROPERTY RIGHTS IS GRANTED BY THIS DOCUMENT. EXCEPT AS PROVIDED IN NUMONYX'S TERMS AND CONDITIONS OF SALE FOR SUCH PRODUCTS, NUMONYX ASSUMES NO LIABILITY WHATSOEVER, AND NUMONYX DISCLAIMS ANY EXPRESS OR IMPLIED WARRANTY, RELATING TO SALE AND/OR USE OF NUMONYX PRODUCTS INCLUDING LIABILITY OR WARRANTIES RELATING TO FITNESS FOR A PARTICULAR PURPOSE, MERCHANTABILITY, OR INFRINGEMENT OF ANY PATENT, COPYRIGHT OR OTHER INTELLECTUAL PROPERTY RIGHT.

Numonyx products are not intended for use in medical, life saving, life sustaining, critical control or safety systems, or in nuclear facility applications.

Numonyx may make changes to specifications and product descriptions at any time, without notice.

Numonyx, B.V. may have patents or pending patent applications, trademarks, copyrights, or other intellectual property rights that relate to the presented subject matter. The furnishing of documents and other materials and information does not provide any license, express or implied, by estoppel or otherwise, to any such patents, trademarks, copyrights, or other intellectual property rights.

Designers must not rely on the absence or characteristics of any features or instructions marked "reserved" or "undefined." Numonyx reserves these for future definition and shall have no responsibility whatsoever for conflicts or incompatibilities arising from future changes to them.

Contact your local Numonyx sales office or your distributor to obtain the latest specifications and before placing your product order.

Copies of documents which have an order number and are referenced in this document, or other Numonyx literature may be obtained by visiting Numonyx's website at <http://www.numonyx.com>.

Numonyx StrataFlash is a trademark or registered trademark of Numonyx or its subsidiaries in the United States and other countries.

*Other names and brands may be claimed as the property of others.

Copyright © 2010, Numonyx B.V. All Rights Reserved.

Looking for pricing, stock, or lifecycle information?

Click below to explore more details on WIN SOURCE:

- ⊖ [View N25Q128A31EF840E on WIN SOURCE](#)
- ⊖ [Micron Technology Inc. Information](#)

Optimize Your Supply Chain with WIN SOURCE Solutions

- ✓ Global Sourcing Solution
- ✓ Obsolete Management
- ✓ Cost Control Management
- ✓ Shortage Management
- ✓ Alternative Solution
- ✓ Excess Inventory Management