



**THE DATASHEET OF
MSP-EXP430FR2355**



MSP430FR2355 LaunchPad™ Development Kit (MSP-EXP430FR2355)

The MSP-EXP430FR2355 LaunchPad™ Development Kit is an easy-to-use Evaluation Module (EVM) for the MSP430FR2355 microcontroller (MCU). The kit contains everything needed to start developing on the ultra-low-power MSP430FRx FRAM microcontroller platform, including onboard debug probe for programming, debugging, and energy measurements. The board also features onboard buttons and LEDs for quick integration of a simple user interface, an onboard Grove connector for external Grove sensors, as well as an ambient light sensor to showcase the integrated analog peripherals.

Figure 1 shows the MSP-EXP430FR2355 LaunchPad development kit.

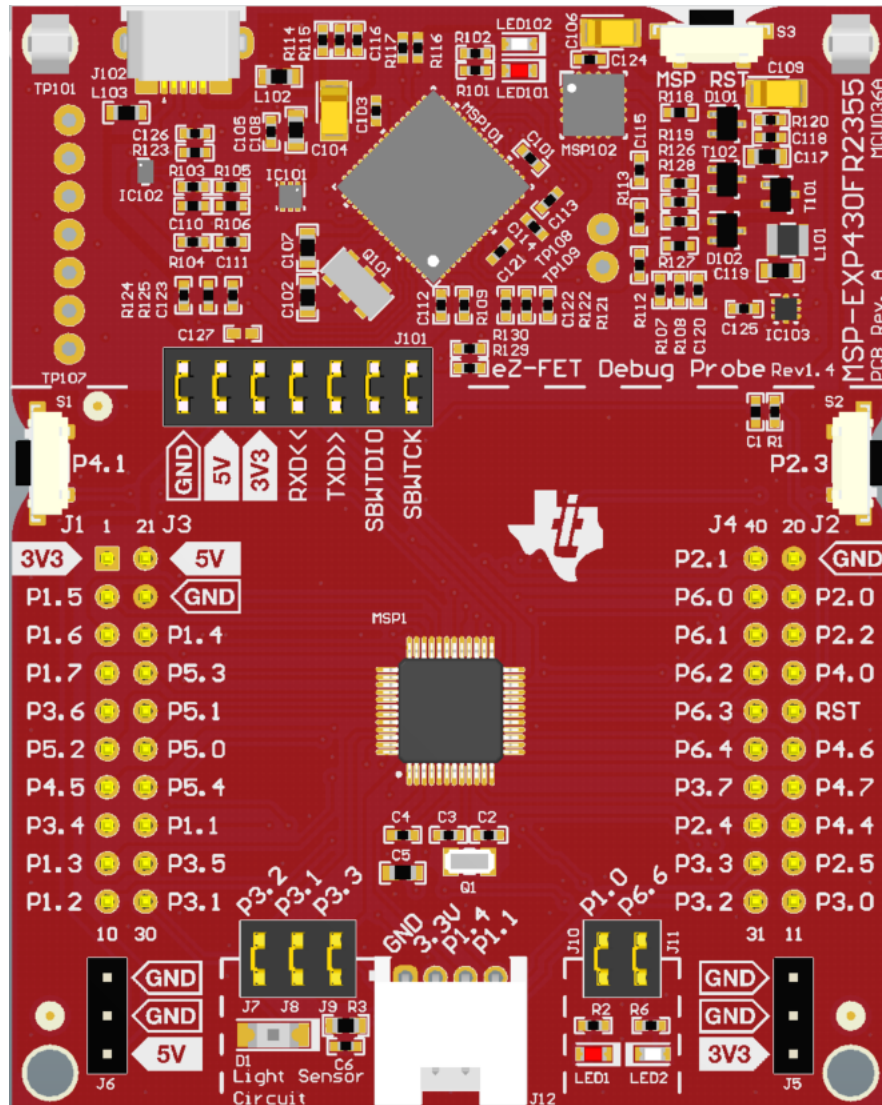

Figure 1. MSP-EXP430FR2355 LaunchPad Development Kit

Contents

1	Getting Started	4
	1.1 Introduction	4
	1.2 Key Features	4
	1.3 What's Included	4
	1.4 First Steps: Out-of-Box Experience	4
	1.5 Next Steps: Looking Into the Provided Code	5
2	Hardware.....	6
	2.1 Block Diagram.....	6
	2.2 Hardware Features	7
	2.3 Power	12
	2.4 Measure Current Draw of the MSP430 MCU.....	12
	2.5 Clocking	13
	2.6 Using the eZ-FET Debug Probe with a Different Target	13
	2.7 BoosterPack Plug-in Module Pinout	13
	2.8 Design Files	15
	2.9 Hardware Change Log.....	15
3	Software Examples	15
	3.1 Out-of-Box Software Example	16
	3.2 Blink LED Example.....	18
4	Resources	18
	4.1 Integrated Development Environments.....	18
	4.2 LaunchPad Development Kit Websites.....	22
	4.3 MSPWare and TI Resource Explorer.....	22
	4.4 FRAM Utilities.....	23
	4.5 MSP430FR2355 MCU	23
	4.6 Community Resources	23
5	FAQ	24
6	Schematics	25

List of Figures

1	MSP-EXP430FR2355 LaunchPad Development Kit.....	1
2	MSP-EXP430FR2355 Overview	6
3	MSP-EXP430FR2355 Block Diagram.....	6
4	MSP430FR2355 Pinout.....	8
5	eZ-FET Debug Probe	9
6	eZ-FET Isolation Jumper Block Diagram	10
7	Application Backchannel UART in Device Manager.....	11
8	MSP-EXP430FR2355 Power Block Diagram.....	12
9	BoosterPack Checker Tool	14
10	LaunchPad Development Kit to BoosterPack Plug-in Module Connector Pinout.....	15
11	Default Waveform of the Function Generator Mode.....	17
12	TI Resource Explorer Cloud	19
13	CCS Cloud	20
14	Directing the Project>Import Function to the Demo Project	21
15	When CCS Has Found the Project	21
16	Using TI Resource Explorer to Browse MSP-EXP430FR2355 in MSPWare	22
17	Schematics (1 of 2)	25
18	Schematics (2 of 2)	26

List of Tables

1	EnergyTrace Technology	9
---	------------------------------	---

2	Isolation Block Connections	10
3	Hardware Change Log	15
4	Software Examples	15
5	IDE Minimum Requirements for MSP-EXP430FR2355	16
6	Source File and Folders	16
7	Source File and Folders	18
8	How MSP Device Documentation is Organized.....	23

Trademarks

LaunchPad, BoosterPack, Code Composer Studio, EnergyTrace, MSP430, E2E are trademarks of Texas Instruments.

IAR Embedded Workbench, C-SPY are registered trademarks of IAR Systems.

All other trademarks are the property of their respective owners.

1 Getting Started

1.1 Introduction

The 24-MHz MSP430FR2355 device features 32KB of embedded FRAM (ferroelectric random access memory), a nonvolatile memory known for its ultra-low power, high endurance, and high speed write access. Combined with 4KB of on-chip RAM, users have access to 32KB of memory to split between their program and data as required. For example, a data logging application may require a large data memory with relatively small program memory, so the memory may be allocated as required between program and data memory.

Rapid prototyping is simplified by the 40-pin BoosterPack™ plug-in module headers, which support a wide range of available BoosterPack plug-in modules. You can quickly add features like wireless connectivity, graphical displays, environmental sensing, and much more. Design your own BoosterPack plug-in module or choose among many already available from TI and third-party developers.

Free software development tools are also available, such as TI's [Eclipse-based Code Composer Studio™ IDE \(CCS\)](#) and [IAR Embedded Workbench® IDE](#). Both of these IDEs support [EnergyTrace™ technology](#) for real-time power profiling and debugging when paired with the MSP430FR2355 LaunchPad development kit.

1.2 Key Features

- MSP ULP FRAM technology based MSP430FR2355 16-bit MCU
- EnergyTrace technology available for ultra-low-power debugging
- 40-pin LaunchPad development kit standard leveraging the BoosterPack plug-in module ecosystem
- Onboard eZ-FET debug probe
- 2 buttons and 2 LEDs for user interaction
- Ambient light sensor for the Out-of-Box Experience demo
- Grove connector for external Grove sensors

1.3 What's Included

1.3.1 Kit Contents

- 1 MSP-EXP430FR2355 LaunchPad Development Kit
- 1 Micro USB cable
- 1 Quick Start Guide

1.3.2 Software Examples

- Out-of-Box Software

1.4 First Steps: Out-of-Box Experience

An easy way to get started with the EVM is by using its preprogrammed out-of-box code. It demonstrates some key features of the EVM.

1.4.1 Connecting to the Computer

Connect the LaunchPad development kit using the included USB cable to a computer. A green power LED should illuminate. For proper operation, drivers are needed. TI recommends that you get the drivers by installing an IDE such as TI's CCS or IAR EW430. Drivers are also available at www.ti.com/MSPdrivers.

1.4.2 Running the Out-of-Box Experience

The Out-of-Box Experience (OOBE) of the MSP-EXP430FR2355 LaunchPad development kit demonstrates how to set up multiple integrated Smart Analog Combo (SAC) peripherals of the MSP430FR2355 MCU and how to use the interconnections between SAC pairs in various demo scenarios. The OOBE includes two modes, a Light Sensor mode and a Function Generator mode. In the Function Generator mode, the LaunchPad development kit transmits digital data to the PC and can be visualized using the accompanying cloud GUI (visit [MSP-EXP430FR2355 OOB GUI](#)).

By default after power up, the MSP-EXP430FR2355 LaunchPad development kit enters the Light Sensor mode, in which LED1 or LED2 brightens or dims based on the amount of ambient light sensed by the photodiode, D1. A default brightness threshold is set at approximately half of the full brightness detection range of D1 at which both LED1 and LED2 are off. Shine a light source such as a flashlight or cover up D1 using your hand, and notice the green LED2 gets brighter as more light reaches D1, while the red LED1 gets brighter as less light reaches D1. Press button S1 in the Light Sensor mode to set the new brightness threshold at the current ambient light level.

Next, try pressing S2 to enter Function Generator mode. By default, the LaunchPad development kit starts to generate a 1-Hz inverted sine wave at 0.8-V amplitude on pin P1.5. This signal is a result of using one of the SAC 12-bit DACs to generate a sine wave and feeding it into a second SAC, which is configured as an inverting programmable gain amplifier (PGA). The resulting waveform on pin P1.5 is also captured by the MSP430FR2355 internal ADC, and the live data are transmitted to the PC. An accompanying cloud GUI (visit [MSP-EXP430FR2355 OOB GUI](#)) is available to visualize the ADC measurements of the generated waveform. This GUI also provides various controls for changing the signal type (sinusoidal, square, or sawtooth), frequency, and amplitude of the DAC waveform generation and for configuring the PGA mode (inverting or noninverting) and gain. See [Section 3.1](#) for more details on the OOBE and how to use its accompanying cloud GUI.

This GUI is created with [GUI Composer 2.0](#) with the source available for customization, imported from the [TI Cloud Gallery](#). The serial communication port on the PC must be configured with 115200 bps, one stop bit, and no flow control.

NOTE: The OOB cloud GUI is only supported in the latest versions of Chrome, Firefox, and Safari browsers. An installer for the offline standalone GUI can also be downloaded from the [TI Cloud Gallery](#).

1.5 Next Steps: Looking Into the Provided Code

After the EVM features have been explored, the fun can begin. It's time to open an integrated development environment and start editing the code examples. See [Section 4](#) for available IDEs and where to download them.

The quickest way to get started using the LaunchPad development kit is to use [TI's Cloud Development Tools](#). The cloud-based Resource Explorer provides access to all of the examples and resources in MSPWare. Code Composer Studio Cloud is a simple Cloud-based IDE that enables developing and running applications on the LaunchPad development kit.

The out-of-box source code and more code examples are provided and available on the [download page](#). Code is licensed under BSD, and TI encourages reuse and modifications to fit specific needs.

[Section 3](#) describes all functions in detail and provides a project structure to help familiarize you with the code.

With the onboard eZ-FET debug probe, debugging and downloading new code is simple. A USB connection between the EVM and a PC through the provided USB cable is all that is needed.

2 Hardware

Figure 2 shows an overview of the MSP-EXP430FR2355 hardware.

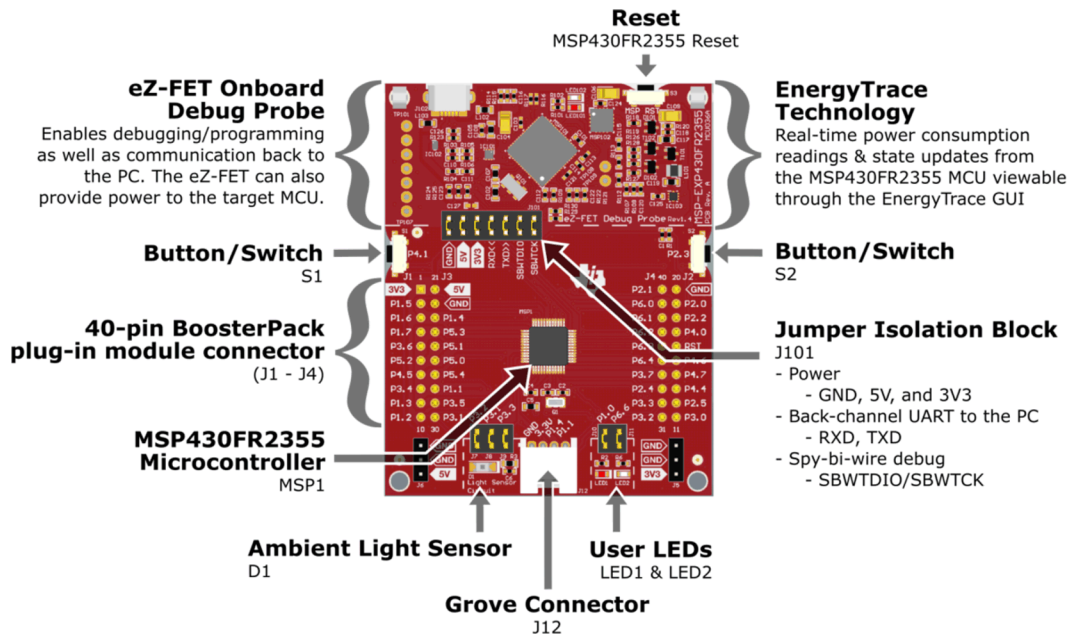

Figure 2. MSP-EXP430FR2355 Overview

2.1 Block Diagram

Figure 3 shows the block diagram.

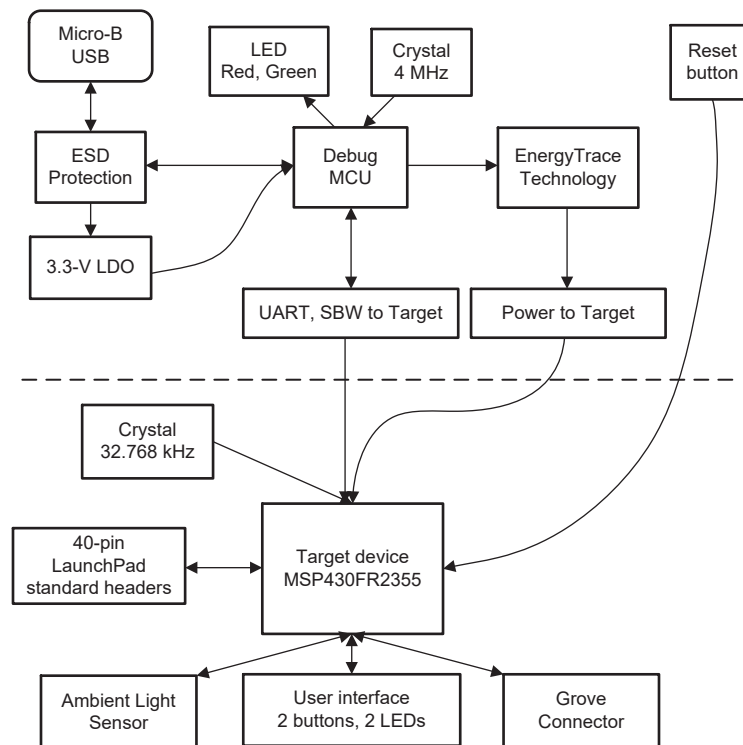

Figure 3. MSP-EXP430FR2355 Block Diagram

2.2 Hardware Features

2.2.1 MSP430FR2355 MCU

The MSP430FR2355 is an ultra-low-power MSP430FRx FRAM-based microcontroller (MCU), which offer extended data logging and security capabilities. The MSP430FR2355 offers the small LQFP package (7 mm × 7 mm) in the FRAM microcontroller portfolio, combined with a variety of integrated peripherals and ultra-low power consumption. FRAM is a cutting edge memory technology, combining the best features of flash and RAM into one nonvolatile memory. More information on FRAM can be found at www.ti.com/fram.

Device features include:

- 1.8-V to 3.6-V operation
- 16-Bit RISC architecture up to 24-MHz system clock and 8-MHz FRAM access
- 32KB of Program FRAM, 512 bytes of Information FRAM, and 4KB of RAM
- 12-channel 12-bit ADC
- Two enhanced comparator with integrated 6-bit DAC as reference voltage
- Four Smart Analog Combo (SAC-L3)
- Three 16-bit timers with three capture/compare registers (Timer_B3)
- One 16-bit timer with seven capture/compare registers (Timer_B7)
- 32-bit hardware multiplier (MPY)
- 44 GPIOs

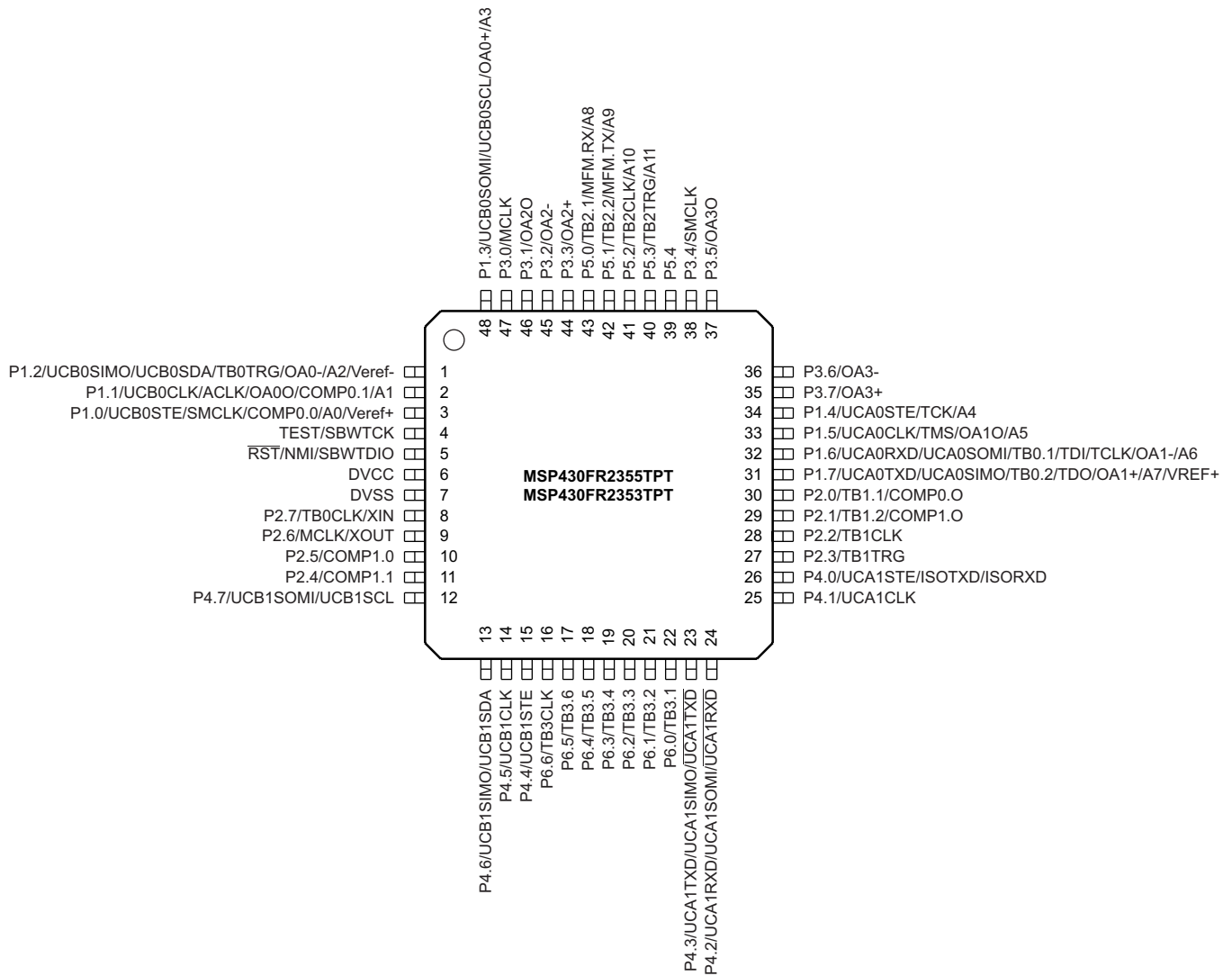

Figure 4. MSP430FR2355 Pinout

2.2.2 eZ-FET Onboard Debug Probe With EnergyTrace™ Technology

To keep development easy and cost effective, TI's LaunchPad development kits integrate an onboard debug probe, which eliminates the need for expensive programmers. The MSP-EXP430FR2355 has the eZ-FET debug probe (see [Figure 5](#)), which is a simple and low-cost debugger that supports all MSP430™ device derivatives.

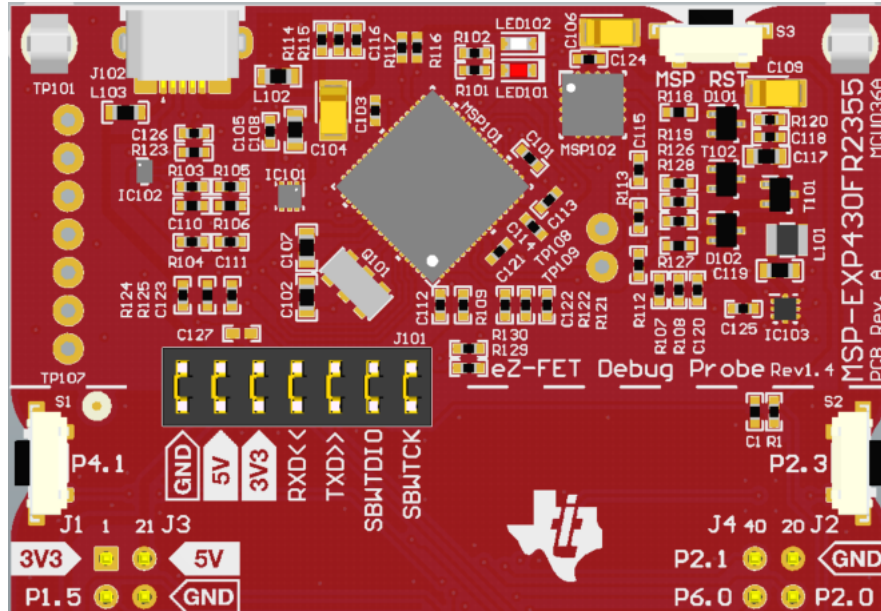

Figure 5. eZ-FET Debug Probe

The MSP-EXP430FR2355 LaunchPad development kit features EnergyTrace technology but does not have support for EnergyTrace++ technology. The EnergyTrace technology functionality varies across the MSP portfolio.

Table 1. EnergyTrace Technology

Features	EnergyTrace Technology	EnergyTrace++ Technology
Current Monitoring	✓	✓
CPU State		✓
Peripheral and System State		✓
Devices Supported	All MSP430 MCUs	MSP430FR59xx and MSP430FR69xx MCUs
Development Tool Required	MSP-FET or eZ-FET	MSP-FET or eZ-FET

The dotted line through J101 shown in [Figure 5](#) divides the eZ-FET debug probe from the target area. The signals that cross this line can be disconnected by jumpers on J101, the isolation jumper block. More details on the isolation jumper block are in [Section 2.2.3](#).

The eZ-FET also provides a "backchannel" UART-over-USB connection with the host, which can be very useful during debugging and for easy communication with a PC. More details can be found in [Section 2.2.4](#).

The eZ-FET hardware can be found in the schematics in [Section 6](#) and in the [hardware design files download page](#). The software and more information about the debugger can be found on the [eZ-FET wiki](#).

2.2.3 Debug Probe Connection: Isolation Jumper Block

The isolation jumper block at jumper J101 allows the user to connect or disconnect signals that cross from the eZ-FET domain into the MSP430FR2355 target domain. This includes eZ-FET Spy-Bi-Wire signals, application UART signals, and 3.3-V and 5-V power.

Reasons to open these connections:

- To remove any and all influence from the eZ-FET debug probe for high accuracy target power measurements
- To control 3-V and 5-V power flow between the eZ-FET and target domains
- To expose the target MCU pins for other use than onboard debugging and application UART communication
- To expose the programming and UART interface of the eZ-FET so that it can be used for devices other than the onboard MCU.

Table 2. Isolation Block Connections

Jumper	Description
GND	Ground
5V	5-V VBUS from USB
3V3	3.3-V rail, derived from VBUS in the eZ-FET domain
RXD <<	Backchannel UART: The target FR2355 receives data through this signal. The arrows indicate the direction of the signal.
TXD >>	Backchannel UART: The target FR2355 sends data through this signal. The arrows indicate the direction of the signal.
SBW RST	Spy-Bi-Wire debug: SBWTDIO data signal. This pin also functions as the RST signal (active low).
SBW TST	Spy-Bi-Wire debug: SBWTCK clock signal. This pin also functions as the TST signal.

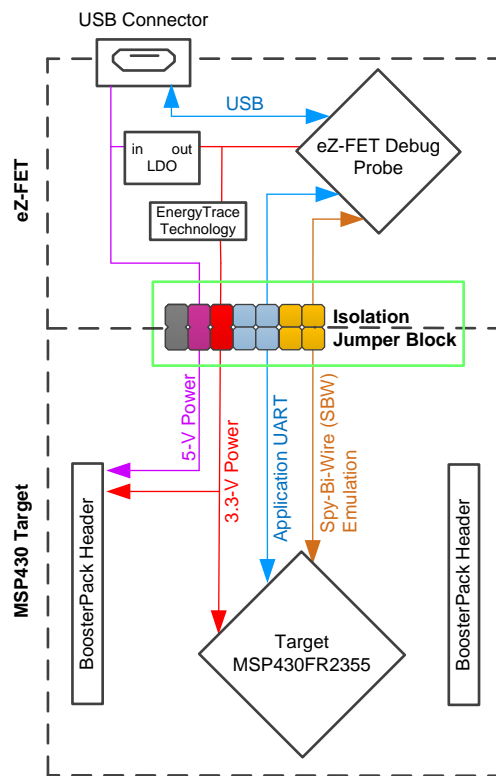

Figure 6. eZ-FET Isolation Jumper Block Diagram

2.2.4 Application (or "Backchannel") UART

The backchannel UART allows communication with the USB host that is not part of the target application's main functionality. This is very useful during development, and also provides a communication channel to the PC host side. This can be used to create graphical user interfaces (GUIs) and other programs on the PC that communicate with the LaunchPad development kit.

Figure 6 shows the pathway of the backchannel UART. The backchannel UART is the UART on eUSCI_A1.

On the host side, a virtual COM port for the application backchannel UART is generated when the LaunchPad development kit enumerates on the host. You can use any PC application that interfaces with COM ports, including terminal applications like Hyperterminal or Docklight, to open this port and communicate with the target application. You need to identify the COM port for the backchannel. On Windows PCs, Device Manager can assist.

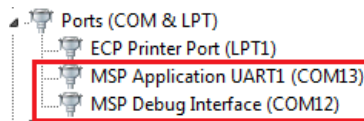

Figure 7. Application Backchannel UART in Device Manager

The backchannel UART is the "MSP Application UART1" port. In this case, Figure 7 shows COM13, but this port can vary from one host PC to the next. After you identify the correct COM port, configure it in your host application according to its documentation. You can then open the port and begin communication to it from the host.

On the target MSP430FR2355 side, the backchannel is connected to the eUSCI_A1 module. The eZ-FET has a configurable baud rate; therefore, it is important that the PC application configures the baud rate to be the same as what is configured on the eUSCI_A1.

2.2.5 Special Features

2.2.5.1 Smart Analog Combo (SAC)

The MSP430FR2355 MCU LaunchPad development kit features pins to access the SAC on the device. These pins are accessed on jumpers J7, J8 and J9 where the SAC operational amplifier is connected to the onboard photodiode circuit. These pins are also connected to the BoosterPack plug-in module header pins. For applications that use the SAC and a connected BoosterPack plug-in module, be sure to check for any pin conflicts. The photodiode circuit can be disconnected from the SAC using jumpers J7, J8 and J9. The user can connect an external analog sensor circuit to the SAC by removing jumpers J7, J8 and J9 and connecting their circuit to the appropriate header pins through the BoosterPack plug-in module headers or the jumpers near the light sensor circuit. To adjust the sensitivity of the light sensor circuit, the user can adjust either the software or the hardware. By changing the values of R3 and C6, the user can change the operational amplifier low-pass filter and sensitivity to the current of the photodiode. The user can also adjust the calculations performed in the software to adjust the sensitivity of the circuit to their desired level.

2.2.5.2 Grove Connector

The MSP430FR2355 MCU LaunchPad development kit features an onboard Grove connector for Analog and Digital Grove modules from Seeed Studio. The Grove connector consists of 4 pins that are routed to 3.3 V, GND, P1.1, and P1.4. Users can take advantage of this connector and begin prototyping with different Grove sensors and actuators without the need to interface the LaunchPad development kit with a Grove Base BoosterPack plug-in module.

2.3 Power

The board accommodates various powering methods, including through the onboard eZ-FET as well as external or BoosterPack plug-in module power (see Figure 8).

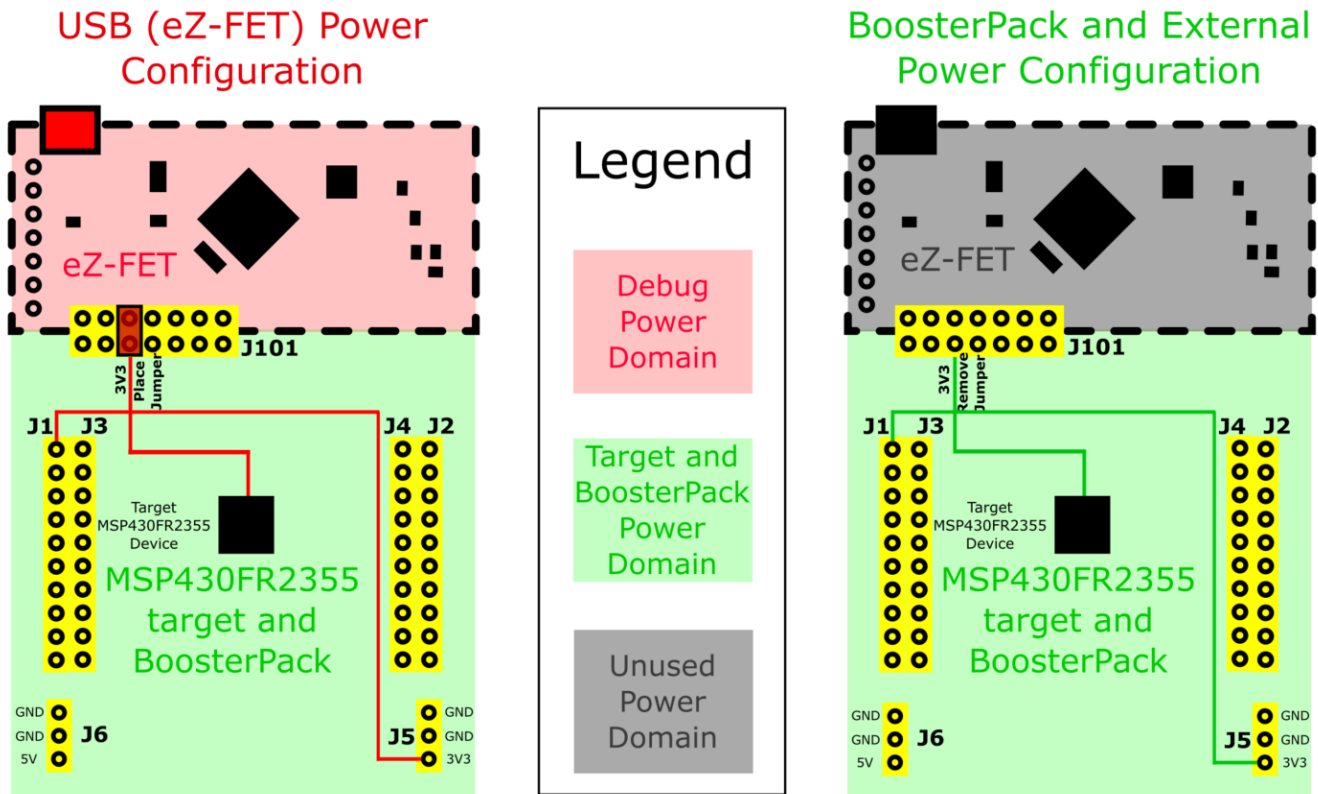

Figure 8. MSP-EXP430FR2355 Power Block Diagram

2.3.1 eZ-FET USB Power

The most common power-supply scenario is from USB through the eZ-FET debugger. This provides 5-V power from the USB and also regulates this power rail to 3.3 V for eZ-FET operation and 3.3 V to the target side of the LaunchPad development kit. Power from the eZ-FET is controlled by jumper J101. For 3.3 V, make sure that a jumper is connected across the J101 3V3 terminal.

2.3.2 BoosterPack Plug-in Module and External Power Supply

Header J5 is present on the board to supply external power directly. It is important to comply with the device voltage operation specifications when supplying external power. The MSP430FR2355 has an operating range of 1.8 V to 3.6 V. More information can be found in the [MSP430FR2355 Mixed-Signal Microcontroller data sheet](#).

2.4 Measure Current Draw of the MSP430 MCU

To measure the current draw of the MSP430FR2355 MCU using a multimeter, use the 3V3 jumper on the J101 jumper isolation block. The current measured includes the target device and any current drawn through the BoosterPack plug-in module headers.

To measure ultra-low power, follow these steps:

- Remove the 3V3 jumper in the J101 isolation block, and attach an ammeter across this jumper.
- Consider the effect that the backchannel UART and any circuitry attached to the MSP430FR2355 may have on current draw. Consider disconnecting these at the isolation jumper block, or at least consider their current sinking and sourcing capability in the final measurement.

- Make sure there are no floating inputs/outputs (I/Os) on the MSP430FR2355. These cause unnecessary extra current draw. Every I/O should either be driven out or, if it is an input, should be pulled or driven to a high or low level.
- Begin target execution.
- Measure the current. Keep in mind that if the current levels are fluctuating, it may be difficult to get a stable measurement. It is easier to measure quiescent states.

EnergyTrace technology can also be used to compare various current profiles and better optimize your energy performance!

2.5 Clocking

The MSP-EXP430FR2355 provides an external clock in addition to the internal clocks in the device.

- Q1: 32.768-kHz 12.5-pF crystal

The 32.768-kHz crystal allows for lower LPM sleep currents than do the other low-frequency clock sources. Therefore, the presence of the crystal allows the full range of low-power modes to be used.

The internal clocks in the device default to the following configuration:

- MCLK: DCO at 1 MHz
- SMCLK: DCO at 1 MHz
- ACLK: REFO at 32.768 kHz

For more information about configuring internal clocks and using the external oscillators, see the [MSP430FR4xx and MSP430FR2xx Family User's Guide](#).

2.6 Using the eZ-FET Debug Probe with a Different Target

The eZ-FET debug probe on the LaunchPad development kit can interface to most MSP430 derivative devices, not just the onboard MSP430FR2355 target device.

To do this, disconnect every jumper in the isolation jumper block. This is necessary, because the debug probe cannot connect to more than one target at a time over the Spy-Bi-Wire (SBW) connection.

Next, make sure the target board has proper connections for SBW. Note that to be compatible with SBW, the capacitor on $\overline{\text{RST}}/\text{SBWTDIO}$ cannot be greater than 2.2 nF. The documentation for designing MSP430 JTAG interface circuitry is the [MSP430 Hardware Tools User's Guide](#).

Finally, wire together these signals from the debug probe side of the isolation jumper block to the target hardware:

- 5 V (if 5 V is needed)
- 3.3 V
- GND
- SBWTDIO
- SBWTCK
- TXD (if the UART backchannel is to be used)
- RXD (if the UART backchannel is to be used)

This wiring can be done either with jumper wires or by designing the board with a connector that plugs into the isolation jumper block.

2.7 BoosterPack Plug-in Module Pinout

The LaunchPad development kit adheres to the 40-pin LaunchPad development kit pinout standard. A standard was created to aid compatibility between LaunchPad development kits and BoosterPack plug-in modules across the TI ecosystem.

While most BoosterPack plug-in modules are compliant with the standard, some are not. The MSP-EXP430FR2355 LaunchPad development kit is compatible with all 40-pin BoosterPack plug-in modules that are compliant with the standard. If the reseller or owner of the BoosterPack plug-in module does not explicitly indicate compatibility with the MSP-EXP430FR2355 LaunchPad development kit, compare the schematic of the candidate BoosterPack plug-in module with the LaunchPad development kit to ensure compatibility. Keep in mind that sometimes conflicts can be resolved by changing the MSP430FR2355 device pin function configuration in software.

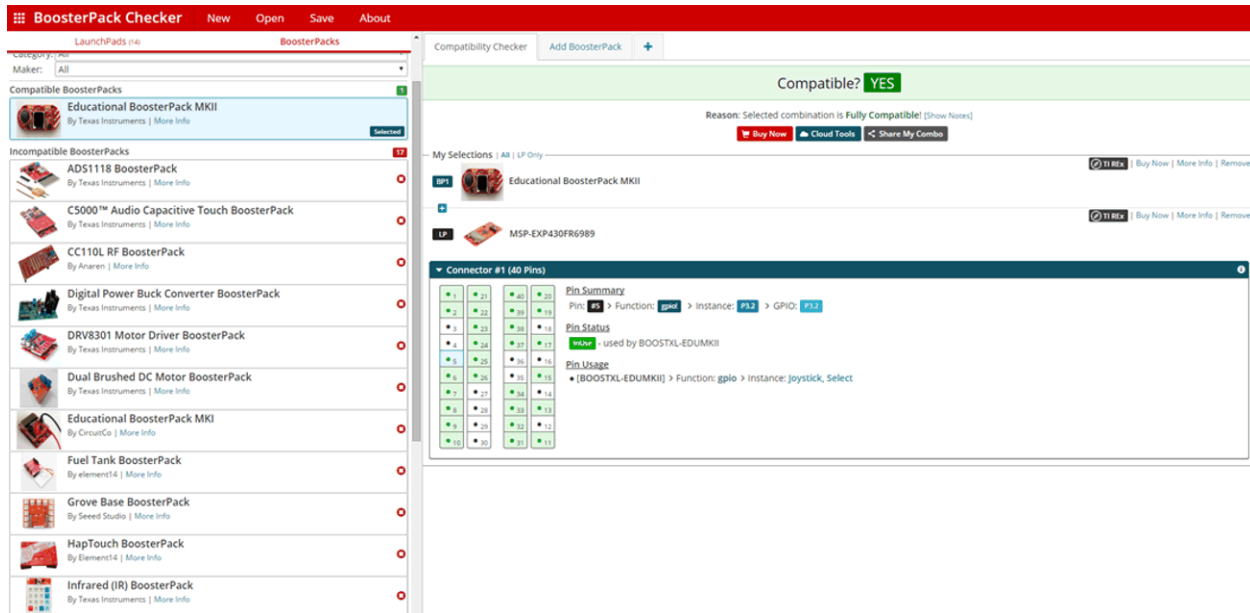

Figure 9. BoosterPack Checker Tool

To check the compatibility of a BoosterPack plug-in module with the LaunchPad development kit of your choice, use the [BoosterPack Checker tool](#). This allows you to select any LaunchPad development kit we offer and determine its compatibility with any number of BoosterPack plug-in modules that we offer. You can also add your own BoosterPack plug-in module to check its compatibility as you prototype that next design.

Figure 10 shows the 40-pin pinout of the MSP430FR2355 LaunchPad development kit.

Note that software's configuration of the pin functions plays a role in compatibility. The LaunchPad development kit side of the dashed line shows only the applicable function for conforming to the standard. However, each pin has other functionality that can be configured by the software. See the MSP430FR2355 device data sheet for more details on individual pin functions.

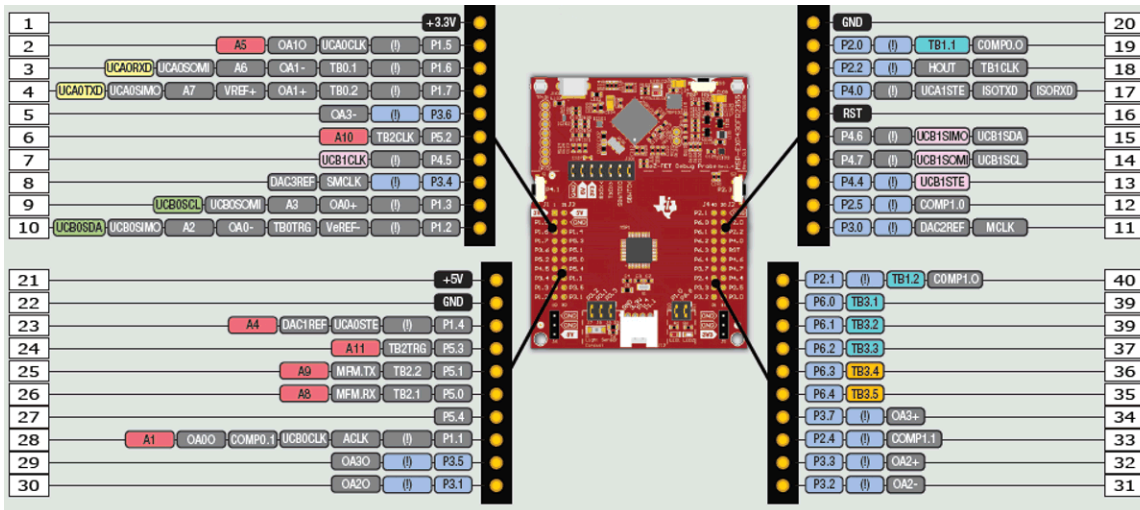

Figure 10. LaunchPad Development Kit to BoosterPack Plug-in Module Connector Pinout

2.8 Design Files

2.8.1 Hardware

Schematics can be found in [Section 6](#). All design files including schematics, layout, bill of materials (BOM), Gerber files, and documentation are available on the [MSP-EXP430FR2355 Design File download page](#).

2.8.2 Software

All design files including TI-TXT object-code firmware images, software example projects, and documentation are available on the [MSP-EXP430FR2355 Design File download page](#).

2.9 Hardware Change Log

[Table 3](#) lists the hardware revision history.

Table 3. Hardware Change Log

PCB Revision	Description
Rev A	Initial release

3 Software Examples

Two software examples are included with the MSP430FR2355 LaunchPad development kit (see [Table 4](#)), which can be found in the [MSP430FR2355 LaunchPad development kit download page](#) and are also available inside [MSPWare](#).

Table 4. Software Examples

Demo Name	BoosterPack Plug-in Module Required	Description	More Details
OutofBox_MSP-EXP430FR2355	None	The out-of-box demo preprogrammed on the LaunchPad development kit from the factory. Demonstrates features of MSP430FR2355 device	Section 3.1
BlinkLED_MSP-EXP430FR2355	None	Blinks an LED on the LaunchPad development kit at a fixed interval	Section 3.2

To use any of the software examples with the LaunchPad development kit, you must have an integrated development environment (IDE) that supports the MSP430FR2355 device (see [Table 5](#)).

Table 5. IDE Minimum Requirements for MSP-EXP430FR2355

Code Composer Studio IDE	IAR Embedded Workbench for Texas Instruments MSP430 IDE
v8.0 or later	v7.12.1 or later

For more details on how to get started quickly and where to download the latest CCS and IAR IDEs, see [Section 4](#).

3.1 Out-of-Box Software Example

This section describes the functionality and structure of the Out-of-Box software that is preloaded in the EVM.

The Out-of-Box Experience (OOBE) of the MSP-EXP430FR2355 LaunchPad development kit demonstrates how to set up the integrated SAC and use it to condition an analog output so that it can be properly sampled by the ADC converter on the MCU.

3.1.1 Source File Structure

The project is split into multiple files (see [Table 6](#)). This makes it easier to navigate and reuse parts of it for other projects.

Table 6. Source File and Folders

Name	Description
main.c	Out-of-Box demo main function
lightsensor.c	Contains functions for the Light Sensor mode
functiongenerator.c	Contains functions for the Function Generator mode
Library: driverlib	Device driver library
Library: jsmn	Minimalistic third-party library for parsing JSON formatted strings

3.1.2 Overview

Upon powering up the Out-of-Box demo, the board enters the Light Sensor mode where LED1 or LED2 brightens/dims based on the intensity of the ambient light hitting the on-board photodiode. By pressing button S2, the board enters the Function Generator mode where an input signal (sourced internally or externally) is fed into a SAC configured in PGA mode, and the final output waveform is captured with the internal ADC. At any time, press S2 to switch between the Light Sensor mode and Function Generator mode.

When the demo is in Function Generator mode, an online cloud GUI ([MSP-EXP430FR2355 OOB GUI](#)) can be used with the development kit to control the input signal source and visualize the real-time ADC measurement. In addition to S2, the GUI provides buttons that can also be used to switch between modes.

NOTE: The MSP430FR2355 microcontroller is equipped with four on-chip Smart Analog Combos (SAC), which come in pairs of two, SAC0 with SAC2 and SAC1 with SAC3. Each pair of SACs is interconnected, where the output of one SAC can be fed into the input of its paired SAC. The Out-of-Box demonstrates these interconnections and uses one SAC pair in the Light Sensor mode and the second SAC pair in the Function Generator mode.

3.1.3 Light Sensor Mode

The Light Sensor mode uses the SAC0 and SAC2 pair, two Timer_B modules, and the ADC of the MSP430FR2355 MCU, combined with the on-board photodiode and LEDs of the LaunchPad development kit, to implement a simple light sensing application. It configures SAC2 as a generic op-amp and, together with R3 and C6, implements a transimpedance amplifier to convert the photodiode current to a voltage. To measure this voltage with the device's ADC, the output voltage of SAC2 is then fed through SAC0 (configured as a buffer), whose output is connected internally to the ADC.

When the Out-of-Box demo is first programmed onto the LaunchPad development kit, a default ADC threshold is set to approximately half of the full brightness detection range of D1. If the ADC measurement is below this brightness threshold, the red LED1 illuminates, and if the ADC measurement is above the default threshold, the green LED2 illuminates corresponding to the intensity of the ambient light. To recalibrate the threshold to the ADC value measured from the ambient light, press S1. The user can influence the amount of light reaching the photodiode by using a flashlight or covering the photodiode observing the changes in the LED brightness.

3.1.4 Function Generator Mode

In the Function Generator mode, an input signal (sourced internally or externally) is fed into the SAC1 configured in the Programmable Gain Amplifier (PGA) mode to be manipulated and captured with the internal ADC. The LaunchPad kit repeatedly measures and transfers this data to the PC through UART. When the Out-of-Box demo is first programmed onto the LaunchPad development kit, the Function Generator mode is initially configured to generate a 1-Hz sine wave at 0.8-V amplitude using the SAC3 DAC, and the sine wave is fed into SAC1 configured in the inverting PGA mode with a gain of 1. When visualized in the OOB GUI, you should see an inverted sine wave as shown in [Figure 11](#).

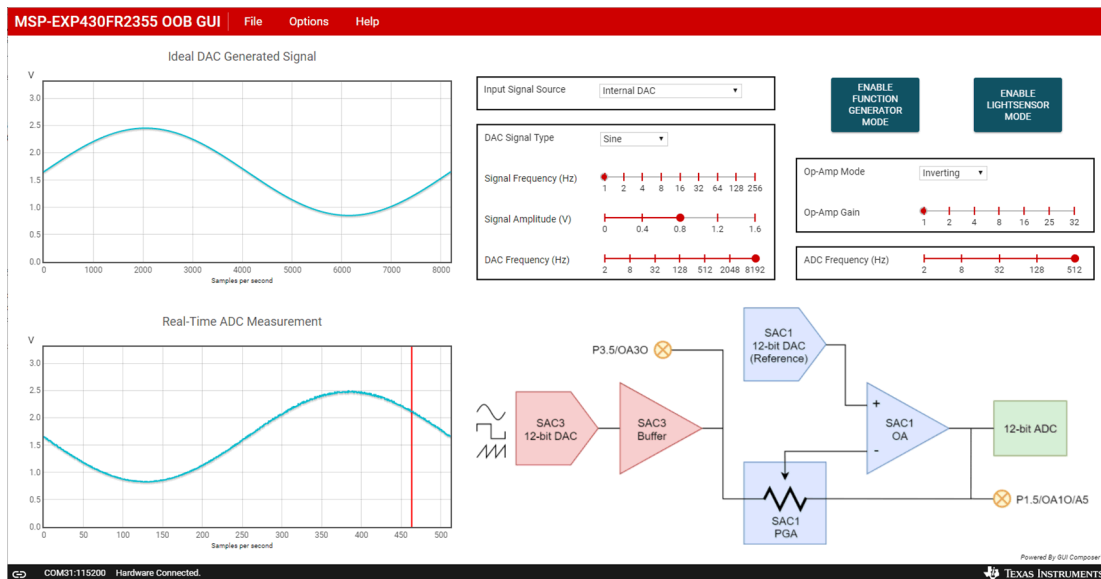

Figure 11. Default Waveform of the Function Generator Mode

Using the GUI, the input signal source can be selected between the internal 12-bit DAC (SAC3) and an external signal source. When the “Internal DAC” is selected as the input signal source, the GUI can be used to generate different types of signals (sinusoidal, square, or sawtooth) of various frequencies and amplitudes. The SAC1 PGA inverting or noninverting gain can be used to manipulate the generated signal of the SAC3 DAC, and the output waveform is captured with the internal ADC connection and displayed on the cloud GUI.

NOTE: When SAC1 is configured in the Inverting PGA mode, the SAC3 DAC generates sine, square, or sawtooth waveforms with a DC bias of +1.65 V, and the SAC1 DAC is used to generate a +1.65-V DC bias for the SAC1 PGA.

When SAC1 is configured in the Noninverting PGA mode, the SAC1 DAC is not available to generate a DC bias for its PGA and is biased to 0 V by default. Therefore, the SAC3 DAC generates sine, square, or sawtooth waveforms with minimum peaks at 0 V.

Alternatively, an external signal source can be directly fed into the inverting input of the SAC1 PGA by selecting "P1.6 OA1- Inverting PGA IN" or the noninverting input of the SAC1 PGA by selecting "P1.7 OA1+ Non-inverting PGA IN" as the input signal source using the GUI. In these two input signal source configurations, the SAC1 PGA inverting or noninverting gain can be used to manipulate the external input signal on P1.6 or P1.7, and the output waveform is captured with the internal ADC connection and displayed on the cloud GUI.

Finally, SAC3 and SAC1 can be completely bypassed by selecting "P1.5 ADC Direct IN" as the input signal source. In this case, an external signal can be connected to P1.5 and measured directly by the internal ADC of the MCU, acting as a primitive oscilloscope.

3.2 Blink LED Example

This simple software example shows how to software toggle a GPIO to blink an LED on the LaunchPad development kit.

3.2.1 Source File Structure

The project is split into multiple files (see [Table 7](#)). This makes it easier to navigate and reuse parts of it for other projects.

Table 7. Source File and Folders

Name	Description
main.c	The Blink LED main function
Library: Driverlib	Device driver library

The main code uses the MSP430 Driver Library to halt the watchdog timer and to configure and toggle the P1.0 GPIO pin connected to the LED inside a software loop.

4 Resources

4.1 Integrated Development Environments

Although the source files can be viewed with any text editor, more can be done with the projects if they're opened with a [development environment](#) like Code Composer Studio IDE (CCS) or IAR Embedded Workbench IDE.

4.1.1 TI Cloud Development Tools

TI's Cloud-based software development tools provide instant access to MSPWare content and a web-based IDE.

4.1.1.1 TI Resource Explorer Cloud

TI Resource Explorer Cloud provides a web interface for browsing examples, libraries and documentation found in MSPWare without having to download files to your local drive.

Go check out TI Resource Explorer Cloud now at dev.ti.com.

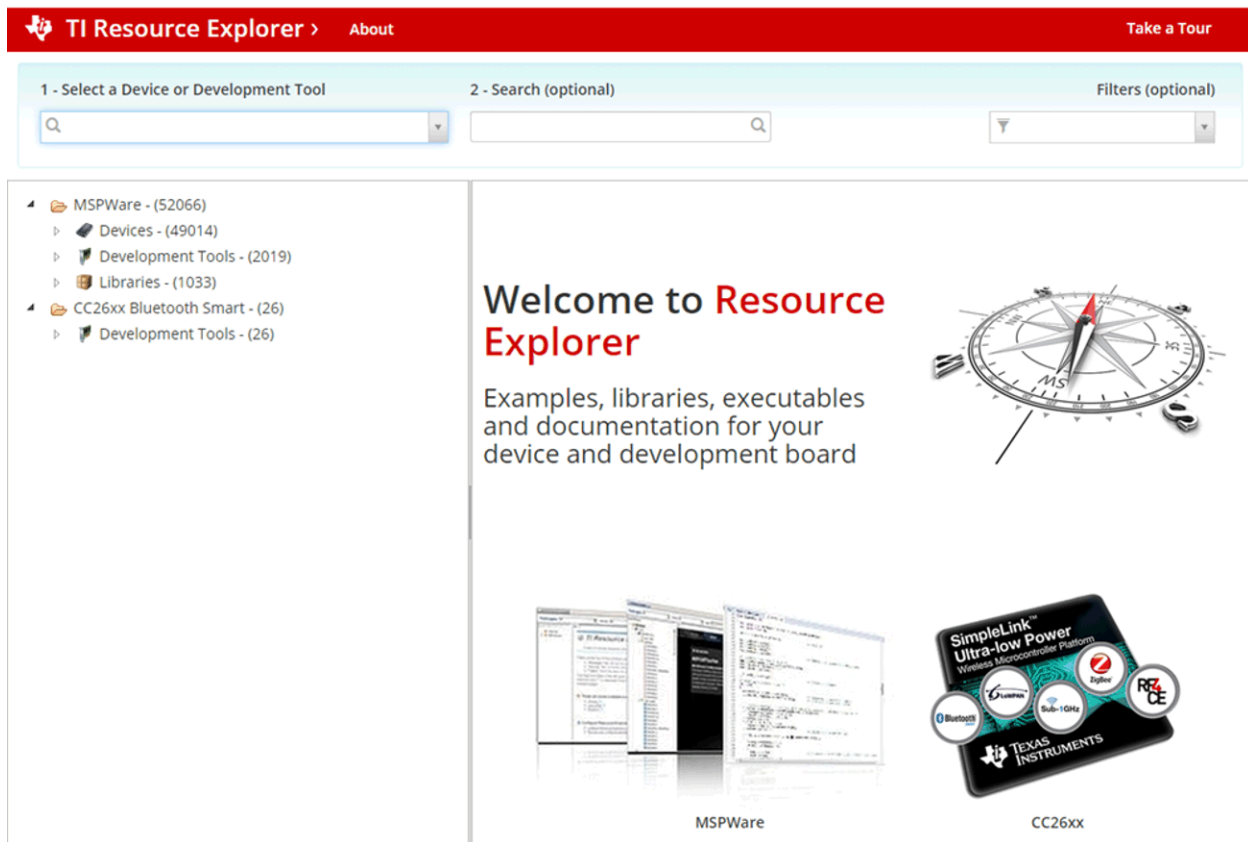

Figure 12. TI Resource Explorer Cloud

4.1.1.2 Code Composer Studio Cloud

Code Composer Studio Cloud (CCS Cloud) is a web-based IDE that enables you to quickly create, edit, build and debug applications for your LaunchPad development kit. No need to download and install large software packages, simply connect your LaunchPad development kit and begin. You can choose to select from a large variety of examples in MSPWare software and Energia or develop your own application. CCS Cloud supports debug features such as execution control, breakpoints and viewing variables.

For more information, see the [full comparison between CCS Cloud and CCS Desktop](#).

Go check out Code Composer Studio Cloud now at dev.ti.com.

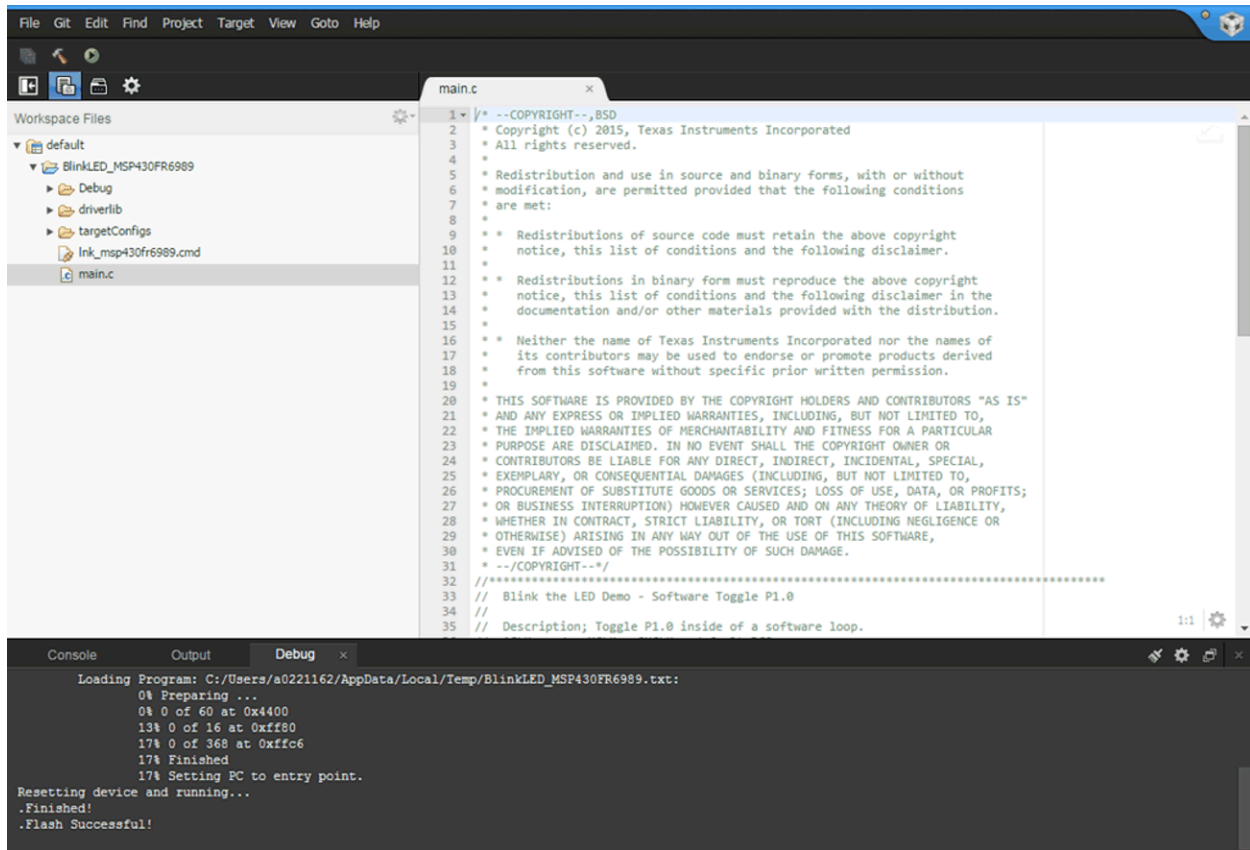

Figure 13. CCS Cloud

4.1.2 Code Composer Studio IDE

Code Composer Studio Desktop is a professional integrated development environment that supports TI's Microcontroller and Embedded Processors portfolio. Code Composer Studio comprises a suite of tools used to develop and debug embedded applications. It includes an optimizing C/C++ compiler, source code editor, project build environment, debugger, profiler, and many other features.

Learn more about CCS and download it at <http://www.ti.com/tool/ccstudio>.

CCS v8.0 or higher is required. When CCS has been launched, and a workspace directory chosen, use Project>Import Existing CCS Eclipse Project. Direct it to the desired demo project directory that contains main.c.

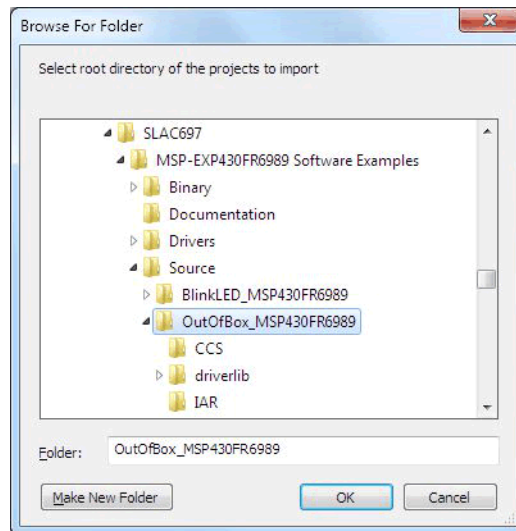

Figure 14. Directing the Project>Import Function to the Demo Project

Selecting the \CCS subdirectory also works. The CCS-specific files are located there.

When you click OK, CCS should recognize the project and allow you to import it. The indication that CCS has found it is that the project appears in the box shown in [Figure 15](#), and it has a checkmark to the left of it.

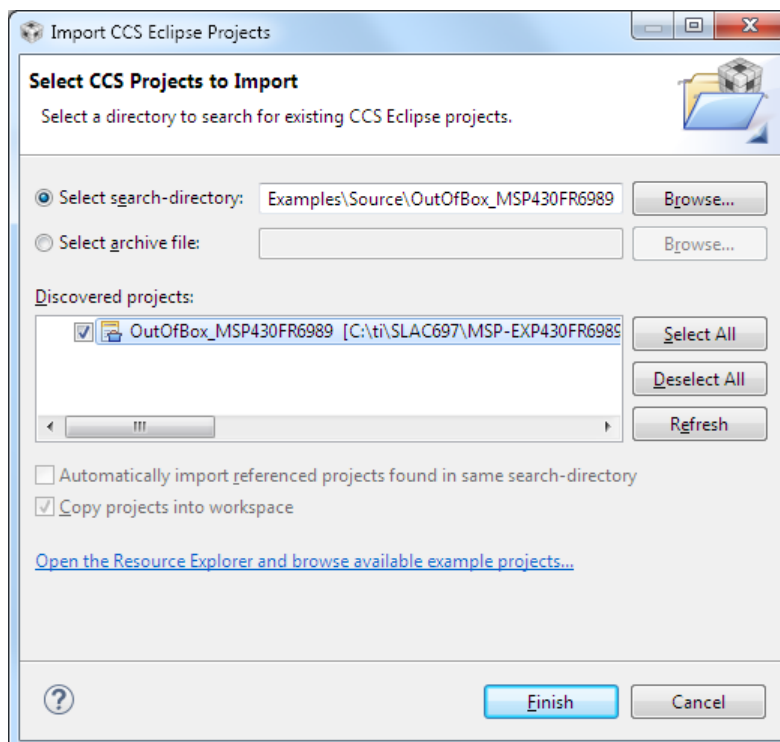

Figure 15. When CCS Has Found the Project

Sometimes CCS finds the project but does not show a checkmark; this might mean that your workspace already has a project by that name. You can resolve this by renaming or deleting that project. (Even if you do not see it in the CCS workspace, be sure to check the workspace directory on the file system.)

4.1.3 IAR Embedded Workbench for Texas Instruments 430 IDE

IAR Embedded Workbench for MSP430 is another very powerful integrated development environment that allows you to develop and manage complete embedded application projects. It integrates the IAR C/C++ Compiler, IAR Assembler, IAR ILINK Linker, editor, project manager, command line build utility, and IAR C-SPY® Debugger.

Learn more about IAR Embedded Workbench for MSP430 and download it at <http://supp.iar.com/Download/SW/?item=EW430-EVAL>.

IAR v7.12.1 or higher is required. To open the demo in IAR, click File>Open>Workspace..., and browse to the *.eww workspace file inside the \IAR subdirectory of the desired demo. All workspace information is contained within this file.

The subdirectory also has an *.ewp project file. This file can be opened into an existing workspace by clicking Project>Add-Existing-Project....

Although the software examples have all of the code required to run them, IAR users may download and install MSPWare, which contains MSP430 libraries and the TI Resource Explorer. These are already included in a CCS installation (unless the user selected otherwise).

4.2 LaunchPad Development Kit Websites

More information about the LaunchPad development kit, supported BoosterPack plug-in modules, and available resources can be found at:

- [MSP-EXP430FR2355 tool folder](#): resources specific to this particular LaunchPad development kit
- [TI's LaunchPad development kit portal](#): information about all LaunchPad development kits from TI

4.3 MSPWare and TI Resource Explorer

TI Resource Explorer is a tool integrated into CCS that allows you to browse through available design resources. TI Resource Explorer will help you quickly find what you need inside packages including MSPWare, ControlSuite, TivaWare and more. TI Resource Explorer is well organized to find everything that you need quickly, and you can import software projects into your workspace in one click!

TI Resource Explorer Cloud is one of the TI Cloud Development tools, and is tightly integrated with CCS Cloud. See [Section 4.1.1](#) for more information.

MSPWare is a collection of code examples, software libraries, data sheets and other design resources for ALL MSP devices delivered in a convenient package – essentially everything developers need to become MSP experts!

In addition to providing a complete collection of existing MSP design resources, MSPWare also includes a high level API called MSP Driver Library. This library makes it easy to talk to MSP hardware. More information can be found at <http://www.ti.com/tool/mspware>.

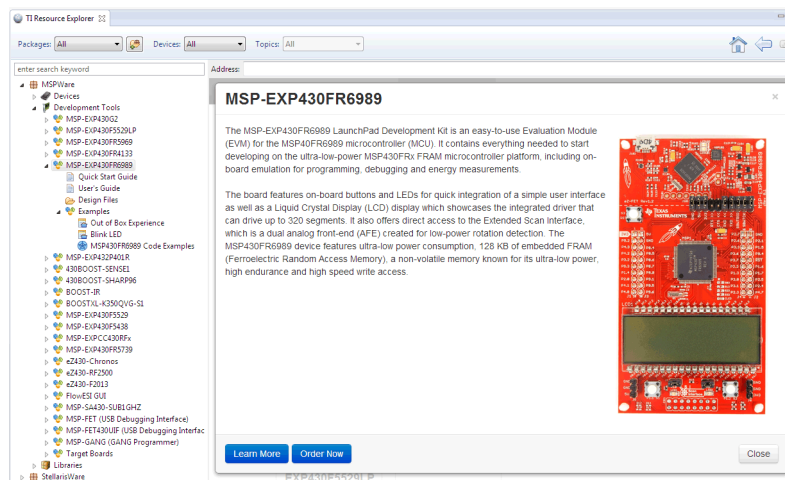

Figure 16. Using TI Resource Explorer to Browse MSP-EXP430FR2355 in MSPWare

Inside TI Resource Explorer, these examples and many more can be found, and easily imported into CCS with one click.

4.4 **FRAM Utilities**

The [Texas Instruments FRAM Utilities](#) is a collection of embedded software utilities that leverage the ultra-low-power and virtually unlimited write endurance of FRAM. The utilities are available for [MSP430FRxx FRAM microcontrollers](#) and provide example code to help start application development.

4.4.1 **Compute Through Power Loss**

Compute Through Power Loss is a utility API set that enables ease of use with LPMx.5 low-power modes and a powerful shutdown mode that allows an application to save and restore critical system components when a power loss is detected.

4.4.2 **Nonvolatile Storage (NVS)**

The nonvolatile storage (NVS) library makes handling of nonvolatile data easy and robust against intermittent power loss or asynchronous device resets. To keep data storage constant, the nonvolatile storage library contains functions that store data in a way that is guaranteed to recover the last valid entry without data corruption.

4.5 **MSP430FR2355 MCU**

4.5.1 **Device Documentation**

At some point, you will probably want more information about the MSP430FR2355 device. For every MSP device, the documentation is organized as shown in [Table 8](#).

Table 8. How MSP Device Documentation is Organized

Document	For MSP430FR2355	Description
Device family user's guide	MSP430FR4xx and MSP430FR2xx Family User's Guide	Architectural information about the device, including all modules and peripherals such as clocks, timers, ADC, and so on
Device-specific data sheet	MSP430FR2355 Mixed-Signal Microcontroller data sheet	Device-specific information and all parametric information for this device

4.5.2 **MSP430FR2355 Code Examples**

[MSP430FR243x, MSP430FR253x, MSP430FR263x Code Examples](#) is a set of simple C examples that demonstrate how to use the entire set of peripherals on the MSP430FR2533 MCU, including serial communication, ADC10, Timer, and others, through direct register access. Every MSP derivative has a set of these code examples. When starting a new project or adding a new peripheral, these examples serve as a great starting point.

4.5.3 **MSP430 Application Notes and TI Designs**

Many application notes can be found at www.ti.com/msp430. Also see [TI Designs](#) for practical design examples and topics.

4.6 **Community Resources**

4.6.1 **TI E2E™ Community**

Search the forums at e2e.ti.com. If you cannot find your answer, post your question to the community!

4.6.2 **Community at Large**

Many online communities focus on the LaunchPad development kit – for example, www.43oh.com. You can find additional tools, resources, and support from these communities.

5 FAQ

Q: I can't get the backchannel UART to connect. What's wrong?

A: Check the following:

- Do the baud rate in the host terminal application and the eUSCI settings match?
- Are the appropriate jumpers in place, on the isolation jumper block?
- Probe on RXD and send data from the host. If you don't see data, it might be a problem on the host side.
- Probe on TXD while sending data from the MSP. If you don't see data, it might be a configuration problem with the eUSCI module.
- Consider the use of the hardware flow control lines (especially for higher baud rates).

Q: The MSP430G2 LaunchPad development kit had a socket, allowing me change the target device. Why doesn't this LaunchPad development kit use one?

A: The target device on this LaunchPad development kit does not come in the dual in-line package. Sockets for the available device package are too expensive for this kit's target price.

6 Schematics

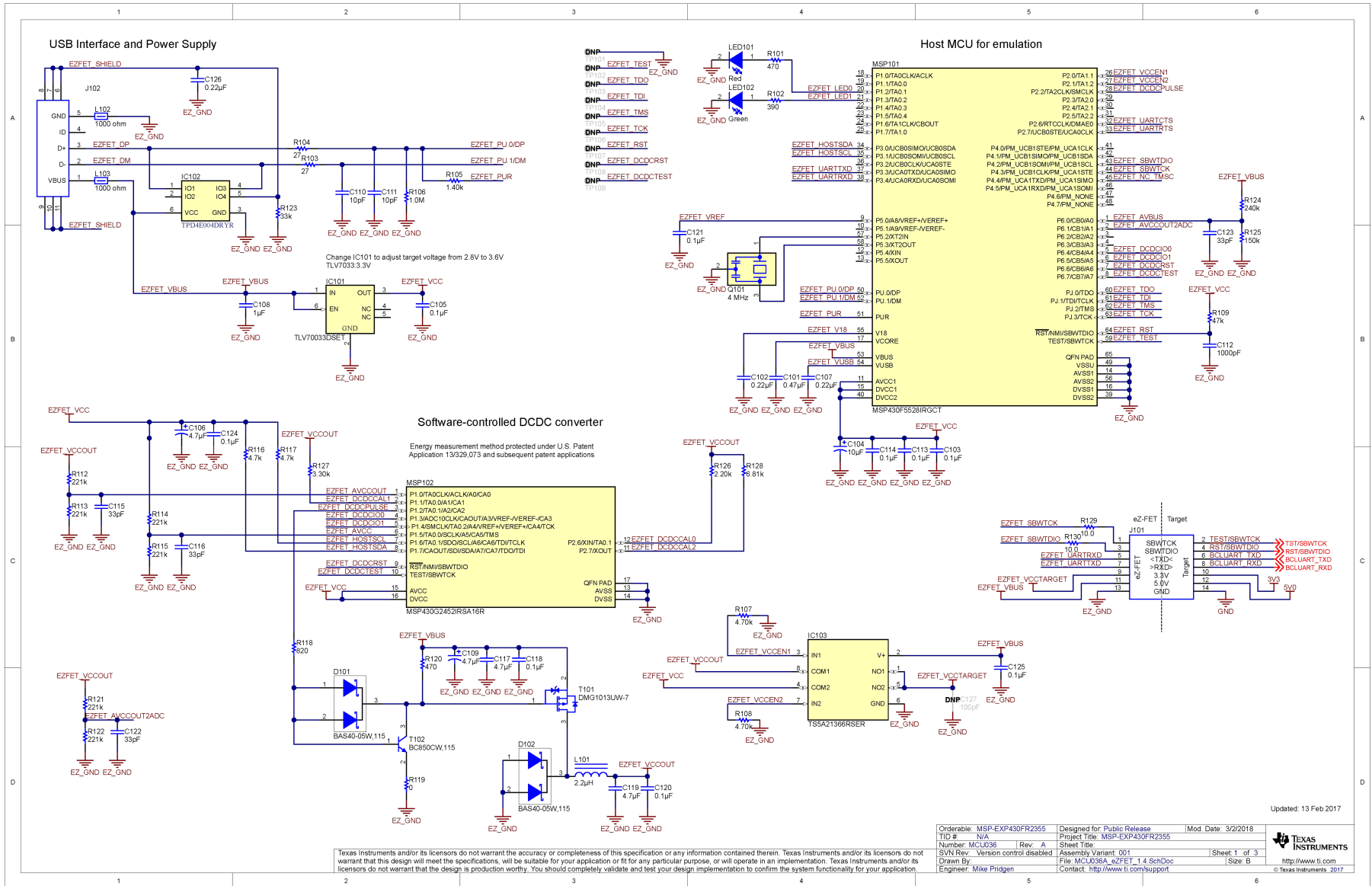

Figure 17. Schematics (1 of 2)

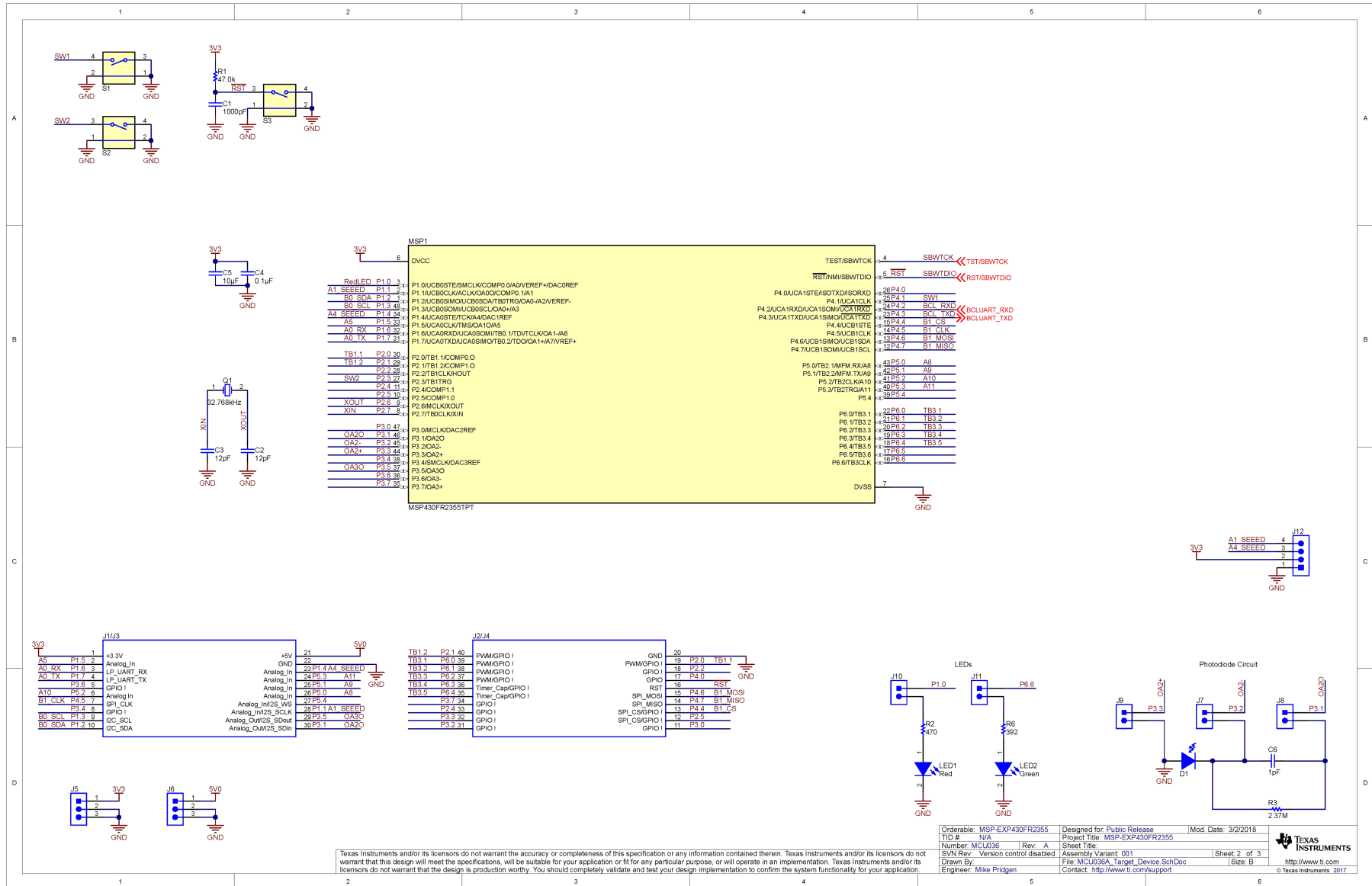

Figure 18. Schematics (2 of 2)

STANDARD TERMS FOR EVALUATION MODULES

1. *Delivery:* TI delivers TI evaluation boards, kits, or modules, including any accompanying demonstration software, components, and/or documentation which may be provided together or separately (collectively, an "EVM" or "EVMs") to the User ("User") in accordance with the terms set forth herein. User's acceptance of the EVM is expressly subject to the following terms.
 - 1.1 EVMs are intended solely for product or software developers for use in a research and development setting to facilitate feasibility evaluation, experimentation, or scientific analysis of TI semiconductor products. EVMs have no direct function and are not finished products. EVMs shall not be directly or indirectly assembled as a part or subassembly in any finished product. For clarification, any software or software tools provided with the EVM ("Software") shall not be subject to the terms and conditions set forth herein but rather shall be subject to the applicable terms that accompany such Software
 - 1.2 EVMs are not intended for consumer or household use. EVMs may not be sold, sublicensed, leased, rented, loaned, assigned, or otherwise distributed for commercial purposes by Users, in whole or in part, or used in any finished product or production system.
2. *Limited Warranty and Related Remedies/Disclaimers:*
 - 2.1 These terms do not apply to Software. The warranty, if any, for Software is covered in the applicable Software License Agreement.
 - 2.2 TI warrants that the TI EVM will conform to TI's published specifications for ninety (90) days after the date TI delivers such EVM to User. Notwithstanding the foregoing, TI shall not be liable for a nonconforming EVM if (a) the nonconformity was caused by neglect, misuse or mistreatment by an entity other than TI, including improper installation or testing, or for any EVMs that have been altered or modified in any way by an entity other than TI, (b) the nonconformity resulted from User's design, specifications or instructions for such EVMs or improper system design, or (c) User has not paid on time. Testing and other quality control techniques are used to the extent TI deems necessary. TI does not test all parameters of each EVM. User's claims against TI under this Section 2 are void if User fails to notify TI of any apparent defects in the EVMs within ten (10) business days after delivery, or of any hidden defects with ten (10) business days after the defect has been detected.
 - 2.3 TI's sole liability shall be at its option to repair or replace EVMs that fail to conform to the warranty set forth above, or credit User's account for such EVM. TI's liability under this warranty shall be limited to EVMs that are returned during the warranty period to the address designated by TI and that are determined by TI not to conform to such warranty. If TI elects to repair or replace such EVM, TI shall have a reasonable time to repair such EVM or provide replacements. Repaired EVMs shall be warranted for the remainder of the original warranty period. Replaced EVMs shall be warranted for a new full ninety (90) day warranty period.

WARNING

Evaluation Kits are intended solely for use by technically qualified, professional electronics experts who are familiar with the dangers and application risks associated with handling electrical mechanical components, systems, and subsystems.

User shall operate the Evaluation Kit within TI's recommended guidelines and any applicable legal or environmental requirements as well as reasonable and customary safeguards. Failure to set up and/or operate the Evaluation Kit within TI's recommended guidelines may result in personal injury or death or property damage. Proper set up entails following TI's instructions for electrical ratings of interface circuits such as input, output and electrical loads.

NOTE:

EXPOSURE TO ELECTROSTATIC DISCHARGE (ESD) MAY CAUSE DEGRADATION OR FAILURE OF THE EVALUATION KIT; TI RECOMMENDS STORAGE OF THE EVALUATION KIT IN A PROTECTIVE ESD BAG.

3 Regulatory Notices:

3.1 United States

3.1.1 Notice applicable to EVMs not FCC-Approved:

FCC NOTICE: This kit is designed to allow product developers to evaluate electronic components, circuitry, or software associated with the kit to determine whether to incorporate such items in a finished product and software developers to write software applications for use with the end product. This kit is not a finished product and when assembled may not be resold or otherwise marketed unless all required FCC equipment authorizations are first obtained. Operation is subject to the condition that this product not cause harmful interference to licensed radio stations and that this product accept harmful interference. Unless the assembled kit is designed to operate under part 15, part 18 or part 95 of this chapter, the operator of the kit must operate under the authority of an FCC license holder or must secure an experimental authorization under part 5 of this chapter.

3.1.2 For EVMs annotated as FCC – FEDERAL COMMUNICATIONS COMMISSION Part 15 Compliant:

CAUTION

This device complies with part 15 of the FCC Rules. Operation is subject to the following two conditions: (1) This device may not cause harmful interference, and (2) this device must accept any interference received, including interference that may cause undesired operation.

Changes or modifications not expressly approved by the party responsible for compliance could void the user's authority to operate the equipment.

FCC Interference Statement for Class A EVM devices

NOTE: This equipment has been tested and found to comply with the limits for a Class A digital device, pursuant to part 15 of the FCC Rules. These limits are designed to provide reasonable protection against harmful interference when the equipment is operated in a commercial environment. This equipment generates, uses, and can radiate radio frequency energy and, if not installed and used in accordance with the instruction manual, may cause harmful interference to radio communications. Operation of this equipment in a residential area is likely to cause harmful interference in which case the user will be required to correct the interference at his own expense.

FCC Interference Statement for Class B EVM devices

NOTE: This equipment has been tested and found to comply with the limits for a Class B digital device, pursuant to part 15 of the FCC Rules. These limits are designed to provide reasonable protection against harmful interference in a residential installation. This equipment generates, uses and can radiate radio frequency energy and, if not installed and used in accordance with the instructions, may cause harmful interference to radio communications. However, there is no guarantee that interference will not occur in a particular installation. If this equipment does cause harmful interference to radio or television reception, which can be determined by turning the equipment off and on, the user is encouraged to try to correct the interference by one or more of the following measures:

- Reorient or relocate the receiving antenna.
- Increase the separation between the equipment and receiver.
- Connect the equipment into an outlet on a circuit different from that to which the receiver is connected.
- Consult the dealer or an experienced radio/TV technician for help.

3.2 Canada

3.2.1 For EVMs issued with an Industry Canada Certificate of Conformance to RSS-210 or RSS-247

Concerning EVMs Including Radio Transmitters:

This device complies with Industry Canada license-exempt RSSs. Operation is subject to the following two conditions:

(1) this device may not cause interference, and (2) this device must accept any interference, including interference that may cause undesired operation of the device.

Concernant les EVMs avec appareils radio:

Le présent appareil est conforme aux CNR d'Industrie Canada applicables aux appareils radio exempts de licence. L'exploitation est autorisée aux deux conditions suivantes: (1) l'appareil ne doit pas produire de brouillage, et (2) l'utilisateur de l'appareil doit accepter tout brouillage radioélectrique subi, même si le brouillage est susceptible d'en compromettre le fonctionnement.

Concerning EVMs Including Detachable Antennas:

Under Industry Canada regulations, this radio transmitter may only operate using an antenna of a type and maximum (or lesser) gain approved for the transmitter by Industry Canada. To reduce potential radio interference to other users, the antenna type and its gain should be so chosen that the equivalent isotropically radiated power (e.i.r.p.) is not more than that necessary for successful communication. This radio transmitter has been approved by Industry Canada to operate with the antenna types listed in the user guide with the maximum permissible gain and required antenna impedance for each antenna type indicated. Antenna types not included in this list, having a gain greater than the maximum gain indicated for that type, are strictly prohibited for use with this device.

Concernant les EVMs avec antennes détachables

Conformément à la réglementation d'Industrie Canada, le présent émetteur radio peut fonctionner avec une antenne d'un type et d'un gain maximal (ou inférieur) approuvé pour l'émetteur par Industrie Canada. Dans le but de réduire les risques de brouillage radioélectrique à l'intention des autres utilisateurs, il faut choisir le type d'antenne et son gain de sorte que la puissance isotrope rayonnée équivalente (p.i.r.e.) ne dépasse pas l'intensité nécessaire à l'établissement d'une communication satisfaisante. Le présent émetteur radio a été approuvé par Industrie Canada pour fonctionner avec les types d'antenne énumérés dans le manuel d'usage et ayant un gain admissible maximal et l'impédance requise pour chaque type d'antenne. Les types d'antenne non inclus dans cette liste, ou dont le gain est supérieur au gain maximal indiqué, sont strictement interdits pour l'exploitation de l'émetteur.

3.3 Japan

3.3.1 *Notice for EVMs delivered in Japan:* Please see http://www.tij.co.jp/lstds/ti_ja/general/eStore/notice_01.page 日本国内に輸入される評価用キット、ボードについては、次のところをご覧ください。
http://www.tij.co.jp/lstds/ti_ja/general/eStore/notice_01.page

3.3.2 *Notice for Users of EVMs Considered "Radio Frequency Products" in Japan:* EVMs entering Japan may not be certified by TI as conforming to Technical Regulations of Radio Law of Japan.

If User uses EVMs in Japan, not certified to Technical Regulations of Radio Law of Japan, User is required to follow the instructions set forth by Radio Law of Japan, which includes, but is not limited to, the instructions below with respect to EVMs (which for the avoidance of doubt are stated strictly for convenience and should be verified by User):

1. Use EVMs in a shielded room or any other test facility as defined in the notification #173 issued by Ministry of Internal Affairs and Communications on March 28, 2006, based on Sub-section 1.1 of Article 6 of the Ministry's Rule for Enforcement of Radio Law of Japan,
2. Use EVMs only after User obtains the license of Test Radio Station as provided in Radio Law of Japan with respect to EVMs, or
3. Use of EVMs only after User obtains the Technical Regulations Conformity Certification as provided in Radio Law of Japan with respect to EVMs. Also, do not transfer EVMs, unless User gives the same notice above to the transferee. Please note that if User does not follow the instructions above, User will be subject to penalties of Radio Law of Japan.

【無線電波を送信する製品の開発キットをお使いになる際の注意事項】 開発キットの中には技術基準適合証明を受けていないものがあります。技術適合証明を受けていないものご使用に際しては、電波法遵守のため、以下のいずれかの措置を取っていただく必要がありますのでご注意ください。

1. 電波法施行規則第6条第1項第1号に基づく平成18年3月28日総務省告示第173号で定められた電波暗室等の試験設備でご使用いただく。
2. 実験局の免許を取得後ご使用いただく。
3. 技術基準適合証明を取得後ご使用いただく。

なお、本製品は、上記の「ご使用にあたっての注意」を譲渡先、移転先に通知しない限り、譲渡、移転できないものとします。

上記を遵守頂けない場合は、電波法の罰則が適用される可能性があることをご留意ください。日本テキサス・インスツルメンツ株式会社
東京都新宿区西新宿 6 丁目 2 4 番 1 号
西新宿三井ビル

3.3.3 *Notice for EVMs for Power Line Communication:* Please see http://www.tij.co.jp/lstds/ti_ja/general/eStore/notice_02.page
電力線搬送波通信についての開発キットをお使いになる際の注意事項については、次のところをご覧ください。http://www.tij.co.jp/lstds/ti_ja/general/eStore/notice_02.page

3.4 European Union

3.4.1 *For EVMs subject to EU Directive 2014/30/EU (Electromagnetic Compatibility Directive):*

This is a class A product intended for use in environments other than domestic environments that are connected to a low-voltage power-supply network that supplies buildings used for domestic purposes. In a domestic environment this product may cause radio interference in which case the user may be required to take adequate measures.

-
- 4 *EVM Use Restrictions and Warnings:*
- 4.1 EVMS ARE NOT FOR USE IN FUNCTIONAL SAFETY AND/OR SAFETY CRITICAL EVALUATIONS, INCLUDING BUT NOT LIMITED TO EVALUATIONS OF LIFE SUPPORT APPLICATIONS.
- 4.2 User must read and apply the user guide and other available documentation provided by TI regarding the EVM prior to handling or using the EVM, including without limitation any warning or restriction notices. The notices contain important safety information related to, for example, temperatures and voltages.
- 4.3 *Safety-Related Warnings and Restrictions:*
- 4.3.1 User shall operate the EVM within TI's recommended specifications and environmental considerations stated in the user guide, other available documentation provided by TI, and any other applicable requirements and employ reasonable and customary safeguards. Exceeding the specified performance ratings and specifications (including but not limited to input and output voltage, current, power, and environmental ranges) for the EVM may cause personal injury or death, or property damage. If there are questions concerning performance ratings and specifications, User should contact a TI field representative prior to connecting interface electronics including input power and intended loads. Any loads applied outside of the specified output range may also result in unintended and/or inaccurate operation and/or possible permanent damage to the EVM and/or interface electronics. Please consult the EVM user guide prior to connecting any load to the EVM output. If there is uncertainty as to the load specification, please contact a TI field representative. During normal operation, even with the inputs and outputs kept within the specified allowable ranges, some circuit components may have elevated case temperatures. These components include but are not limited to linear regulators, switching transistors, pass transistors, current sense resistors, and heat sinks, which can be identified using the information in the associated documentation. When working with the EVM, please be aware that the EVM may become very warm.
- 4.3.2 EVMs are intended solely for use by technically qualified, professional electronics experts who are familiar with the dangers and application risks associated with handling electrical mechanical components, systems, and subsystems. User assumes all responsibility and liability for proper and safe handling and use of the EVM by User or its employees, affiliates, contractors or designees. User assumes all responsibility and liability to ensure that any interfaces (electronic and/or mechanical) between the EVM and any human body are designed with suitable isolation and means to safely limit accessible leakage currents to minimize the risk of electrical shock hazard. User assumes all responsibility and liability for any improper or unsafe handling or use of the EVM by User or its employees, affiliates, contractors or designees.
- 4.4 User assumes all responsibility and liability to determine whether the EVM is subject to any applicable international, federal, state, or local laws and regulations related to User's handling and use of the EVM and, if applicable, User assumes all responsibility and liability for compliance in all respects with such laws and regulations. User assumes all responsibility and liability for proper disposal and recycling of the EVM consistent with all applicable international, federal, state, and local requirements.
5. *Accuracy of Information:* To the extent TI provides information on the availability and function of EVMs, TI attempts to be as accurate as possible. However, TI does not warrant the accuracy of EVM descriptions, EVM availability or other information on its websites as accurate, complete, reliable, current, or error-free.
6. *Disclaimers:*
- 6.1 EXCEPT AS SET FORTH ABOVE, EVMS AND ANY MATERIALS PROVIDED WITH THE EVM (INCLUDING, BUT NOT LIMITED TO, REFERENCE DESIGNS AND THE DESIGN OF THE EVM ITSELF) ARE PROVIDED "AS IS" AND "WITH ALL FAULTS." TI DISCLAIMS ALL OTHER WARRANTIES, EXPRESS OR IMPLIED, REGARDING SUCH ITEMS, INCLUDING BUT NOT LIMITED TO ANY EPIDEMIC FAILURE WARRANTY OR IMPLIED WARRANTIES OF MERCHANTABILITY OR FITNESS FOR A PARTICULAR PURPOSE OR NON-INFRINGEMENT OF ANY THIRD PARTY PATENTS, COPYRIGHTS, TRADE SECRETS OR OTHER INTELLECTUAL PROPERTY RIGHTS.
- 6.2 EXCEPT FOR THE LIMITED RIGHT TO USE THE EVM SET FORTH HEREIN, NOTHING IN THESE TERMS SHALL BE CONSTRUED AS GRANTING OR CONFERRING ANY RIGHTS BY LICENSE, PATENT, OR ANY OTHER INDUSTRIAL OR INTELLECTUAL PROPERTY RIGHT OF TI, ITS SUPPLIERS/LICENSORS OR ANY OTHER THIRD PARTY, TO USE THE EVM IN ANY FINISHED END-USER OR READY-TO-USE FINAL PRODUCT, OR FOR ANY INVENTION, DISCOVERY OR IMPROVEMENT, REGARDLESS OF WHEN MADE, CONCEIVED OR ACQUIRED.
7. *USER'S INDEMNITY OBLIGATIONS AND REPRESENTATIONS.* USER WILL DEFEND, INDEMNIFY AND HOLD TI, ITS LICENSORS AND THEIR REPRESENTATIVES HARMLESS FROM AND AGAINST ANY AND ALL CLAIMS, DAMAGES, LOSSES, EXPENSES, COSTS AND LIABILITIES (COLLECTIVELY, "CLAIMS") ARISING OUT OF OR IN CONNECTION WITH ANY HANDLING OR USE OF THE EVM THAT IS NOT IN ACCORDANCE WITH THESE TERMS. THIS OBLIGATION SHALL APPLY WHETHER CLAIMS ARISE UNDER STATUTE, REGULATION, OR THE LAW OF TORT, CONTRACT OR ANY OTHER LEGAL THEORY, AND EVEN IF THE EVM FAILS TO PERFORM AS DESCRIBED OR EXPECTED.

8. *Limitations on Damages and Liability:*

8.1 *General Limitations.* IN NO EVENT SHALL TI BE LIABLE FOR ANY SPECIAL, COLLATERAL, INDIRECT, PUNITIVE, INCIDENTAL, CONSEQUENTIAL, OR EXEMPLARY DAMAGES IN CONNECTION WITH OR ARISING OUT OF THESE TERMS OR THE USE OF THE EVMS , REGARDLESS OF WHETHER TI HAS BEEN ADVISED OF THE POSSIBILITY OF SUCH DAMAGES. EXCLUDED DAMAGES INCLUDE, BUT ARE NOT LIMITED TO, COST OF REMOVAL OR REINSTALLATION, ANCILLARY COSTS TO THE PROCUREMENT OF SUBSTITUTE GOODS OR SERVICES, RETESTING, OUTSIDE COMPUTER TIME, LABOR COSTS, LOSS OF GOODWILL, LOSS OF PROFITS, LOSS OF SAVINGS, LOSS OF USE, LOSS OF DATA, OR BUSINESS INTERRUPTION. NO CLAIM, SUIT OR ACTION SHALL BE BROUGHT AGAINST TI MORE THAN TWELVE (12) MONTHS AFTER THE EVENT THAT GAVE RISE TO THE CAUSE OF ACTION HAS OCCURRED.

8.2 *Specific Limitations.* IN NO EVENT SHALL TI'S AGGREGATE LIABILITY FROM ANY USE OF AN EVM PROVIDED HEREUNDER, INCLUDING FROM ANY WARRANTY, INDEMNITY OR OTHER OBLIGATION ARISING OUT OF OR IN CONNECTION WITH THESE TERMS, , EXCEED THE TOTAL AMOUNT PAID TO TI BY USER FOR THE PARTICULAR EVM(S) AT ISSUE DURING THE PRIOR TWELVE (12) MONTHS WITH RESPECT TO WHICH LOSSES OR DAMAGES ARE CLAIMED. THE EXISTENCE OF MORE THAN ONE CLAIM SHALL NOT ENLARGE OR EXTEND THIS LIMIT.

9. *Return Policy.* Except as otherwise provided, TI does not offer any refunds, returns, or exchanges. Furthermore, no return of EVM(s) will be accepted if the package has been opened and no return of the EVM(s) will be accepted if they are damaged or otherwise not in a resalable condition. If User feels it has been incorrectly charged for the EVM(s) it ordered or that delivery violates the applicable order, User should contact TI. All refunds will be made in full within thirty (30) working days from the return of the components(s), excluding any postage or packaging costs.

10. *Governing Law:* These terms and conditions shall be governed by and interpreted in accordance with the laws of the State of Texas, without reference to conflict-of-laws principles. User agrees that non-exclusive jurisdiction for any dispute arising out of or relating to these terms and conditions lies within courts located in the State of Texas and consents to venue in Dallas County, Texas. Notwithstanding the foregoing, any judgment may be enforced in any United States or foreign court, and TI may seek injunctive relief in any United States or foreign court.

Mailing Address: Texas Instruments, Post Office Box 655303, Dallas, Texas 75265
Copyright © 2019, Texas Instruments Incorporated

IMPORTANT NOTICE AND DISCLAIMER

TI PROVIDES TECHNICAL AND RELIABILITY DATA (INCLUDING DATASHEETS), DESIGN RESOURCES (INCLUDING REFERENCE DESIGNS), APPLICATION OR OTHER DESIGN ADVICE, WEB TOOLS, SAFETY INFORMATION, AND OTHER RESOURCES "AS IS" AND WITH ALL FAULTS, AND DISCLAIMS ALL WARRANTIES, EXPRESS AND IMPLIED, INCLUDING WITHOUT LIMITATION ANY IMPLIED WARRANTIES OF MERCHANTABILITY, FITNESS FOR A PARTICULAR PURPOSE OR NON-INFRINGEMENT OF THIRD PARTY INTELLECTUAL PROPERTY RIGHTS.

These resources are intended for skilled developers designing with TI products. You are solely responsible for (1) selecting the appropriate TI products for your application, (2) designing, validating and testing your application, and (3) ensuring your application meets applicable standards, and any other safety, security, or other requirements. These resources are subject to change without notice. TI grants you permission to use these resources only for development of an application that uses the TI products described in the resource. Other reproduction and display of these resources is prohibited. No license is granted to any other TI intellectual property right or to any third party intellectual property right. TI disclaims responsibility for, and you will fully indemnify TI and its representatives against, any claims, damages, costs, losses, and liabilities arising out of your use of these resources.

TI's products are provided subject to TI's Terms of Sale (www.ti.com/legal/termsofsale.html) or other applicable terms available either on ti.com or provided in conjunction with such TI products. TI's provision of these resources does not expand or otherwise alter TI's applicable warranties or warranty disclaimers for TI products.

Mailing Address: Texas Instruments, Post Office Box 655303, Dallas, Texas 75265
Copyright © 2019, Texas Instruments Incorporated

Looking for pricing, stock, or lifecycle information?

Click below to explore more details on WIN SOURCE:

- ⊖ [View MSP-EXP430FR2355 on WIN SOURCE](#)
- ⊖ [Texas Instruments](#) Information

Optimize Your Supply Chain with WIN SOURCE Solutions

- ✓ Global Sourcing Solution
- ✓ Obsolete Management
- ✓ Cost Control Management
- ✓ Shortage Management
- ✓ Alternative Solution
- ✓ Excess Inventory Management