



**THE DATASHEET OF  
MSA-0770**



## Data Sheet

### Description

The MSA-0770 is a high performance silicon bipolar Monolithic Microwave Integrated Circuit (MMIC) housed in a hermetic, high reliability package. This MMIC is designed for use as a general purpose 50Ω gain block. Typical applications include narrow and broad band IF and RF amplifiers in industrial and military applications.

The MSA-series is fabricated using Avago's 10 GHz  $f_T$ , 25 GHz  $f_{MAX}$ , silicon bipolar MMIC process which uses nitride self-alignment, ion implantation, and gold metallization to achieve excellent performance, uniformity and reliability. The use of an external bias resistor for temperature and current stability also allows bias flexibility.

### 70 mil Package

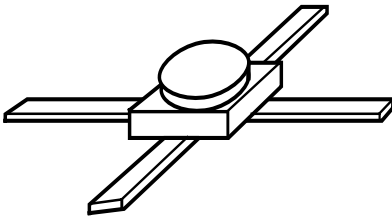

### Features

- Cascadable 50Ω Gain Block
- Low Operating Voltage: 4.0 V Typical  $V_d$
- 3 dB Bandwidth: DC to 2.5 GHz
- 13.0 dB Typical Gain at 1.0 GHz
- Unconditionally Stable ( $k > 1$ )
- Hermetic, Gold-ceramic Microstrip Package

### Typical Biasing Configuration

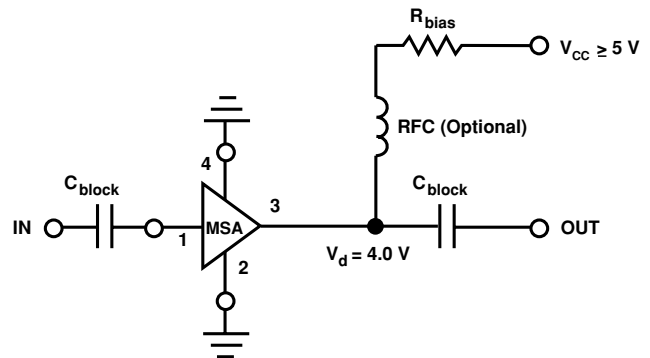

## MSA-0770 Absolute Maximum Ratings

Parameter	Absolute Maximum <sup>[1]</sup>
Device Current	60 mA
Power Dissipation <sup>[2,3]</sup>	275 mW
RF Input Power	+13 dBm
Junction Temperature	200°C
Storage Temperature	-65 to 200°C

Thermal Resistance<sup>[2,4]</sup>:

$$\theta_{jc} = 130^{\circ}\text{C/W}$$

Notes:

1. Permanent damage may occur if any of these limits are exceeded.
2.  $T_{\text{CASE}} = 25^{\circ}\text{C}$ .
3. Derate at 7.7 mW/°C for  $T_C > 164^{\circ}\text{C}$ .
4. This small spot size of this technique results in a higher, though more accurate determination of  $\theta_{jc}$  than do alternate methods.

## Electrical Specifications<sup>[1]</sup>, $T_A = 25^{\circ}\text{C}$

Symbol	Parameters and Test Conditions: $I_d = 22 \text{ mA}$ , $Z_0 = 50 \Omega$	Units	Min.	Typ.	Max.
$G_p$	Power Gain ( $ S_{21} ^2$ ) $f = 0.1 \text{ GHz}$	dB	12.5	13.5	14.5
$\Delta G_p$	Gain Flatness $f = 0.1 \text{ to } 1.5 \text{ GHz}$	dB		$\pm 0.6$	$\pm 1.0$
$f_{3 \text{ dB}}$	3 dB Bandwidth	GHz		2.5	
VSWR	Input VSWR $f = 0.1 \text{ to } 2.5 \text{ GHz}$			2.0:1	
	Output VSWR $f = 0.1 \text{ to } 2.5 \text{ GHz}$			1.6:1	
NF	50 $\Omega$ Noise Figure $f = 1.0 \text{ GHz}$	dB		4.5	
$P_{1 \text{ dB}}$	Output Power at 1 dB Gain Compression $f = 1.0 \text{ GHz}$	dBm		5.5	
$IP_3$	Third Order Intercept Point $f = 1.0 \text{ GHz}$	dBm		19.0	
$t_D$	Group Delay $f = 1.0 \text{ GHz}$	psec		130	
$V_d$	Device Voltage	V	3.6	4.0	4.4
$dV/dT$	Device Voltage Temperature Coefficient	mV/°C		-7.0	

Note:

1. The recommended operating current range for this device is 15 to 40 mA.  
Typical performance as a function of current is on the following page.

MSA-0770 Typical Scattering Parameters ( $Z_0 = 50 \Omega$ ,  $T_A = 25^\circ\text{C}$ ,  $I_d = 22 \text{ mA}$ )

Freq. GHz	$S_{11}$			$S_{21}$			$S_{12}$		$S_{22}$	
	Mag	Ang	dB	Mag	Ang	dB	Mag	Ang	Mag	Ang
0.1	.04	-7	13.5	4.74	175	-18.6	.118	2	.20	-10
0.2	.05	-11	13.5	4.72	170	-18.4	.120	2	.19	-18
0.4	.06	-24	13.4	4.70	160	-18.4	.121	6	.20	-34
0.6	.08	-38	13.4	4.65	151	-18.1	.124	7	.21	-50
0.8	.10	-48	13.2	4.58	141	-17.8	.133	9	.23	-76
1.0	.12	-58	13.0	4.47	131	-17.5	.133	9	.23	-76
1.5	.20	-82	12.3	4.12	107	-16.6	.148	10	.23	-101
2.0	.30	-107	11.6	3.82	85	-15.7	.163	8	.22	-116
2.5	.37	-123	10.4	3.33	70	-15.3	.171	7	.19	-116
3.0	.42	-140	9.0	2.83	52	-15.4	.170	3	.20	-111
3.5	.46	-154	7.7	2.42	37	-15.4	.170	1	.23	-107
4.0	.47	-167	6.4	2.08	23	-15.5	.169	-4	.29	-107
5.0	.47	163	4.2	1.63	-1	-15.5	.167	-9	.35	-116
6.0	.51	131	2.3	1.30	-23	-15.9	.160	-11	.38	-133

Typical Performance,  $T_A = 25^\circ\text{C}$

(unless otherwise noted)

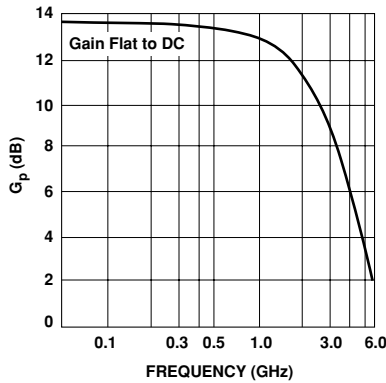

Figure 1. Typical Power Gain vs. Frequency,  $I_d = 22 \text{ mA}$ .

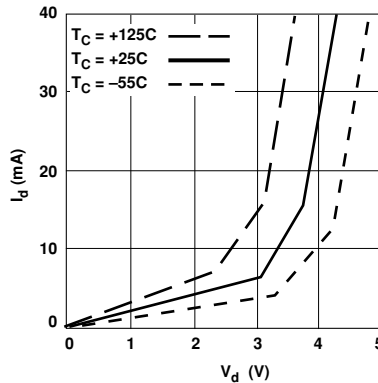

Figure 2. Device Current vs. Voltage.

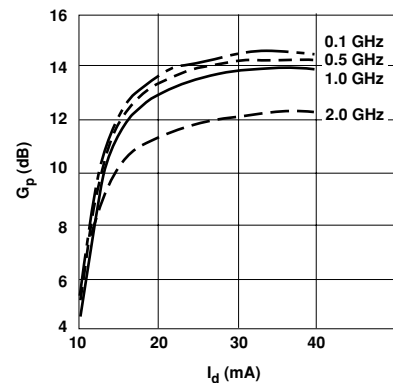

Figure 3. Power Gain vs. Current.

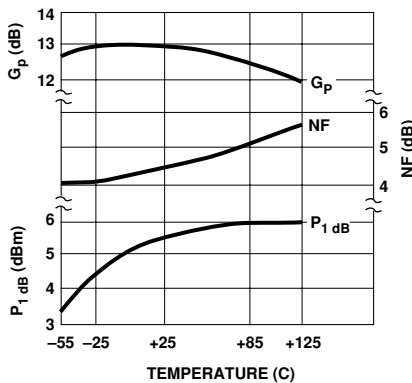

Figure 4. Output Power at 1 dB Gain Compression, NF and Power Gain vs. Case Temperature,  $f = 1.0 \text{ GHz}$ ,  $I_d = 22 \text{ mA}$ .

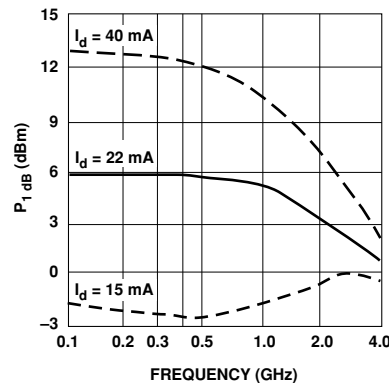

Figure 5. Output Power at 1 dB Gain Compression vs. Frequency.

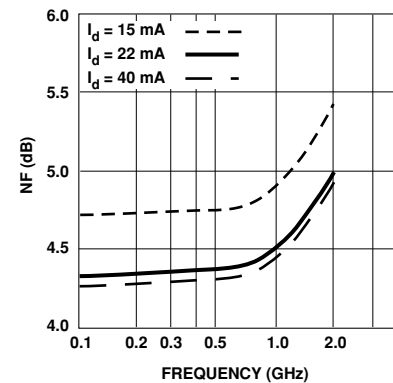
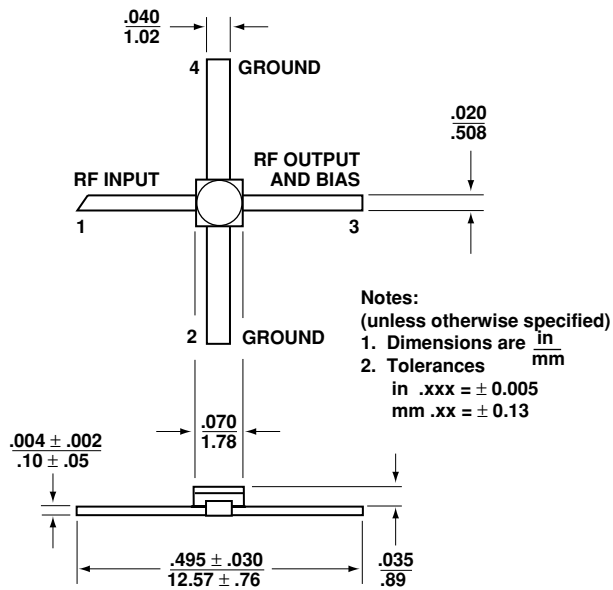

Figure 6. Noise Figure vs. Frequency.

## Ordering Information

Part Numbers	No. of Devices	Comments
MSA-0770	100	Bulk

## 70 mil Package Dimensions



For product information and a complete list of distributors, please go to our web site: [www.avagotech.com](http://www.avagotech.com)

Avago, Avago Technologies, and the A logo are trademarks of Avago Technologies, Limited in the United States and other countries. Data subject to change. Copyright © 2008 Avago Technologies, Limited. All rights reserved. Obsoletes 5989-2761EN AV02-1230EN - May 15, 2008

**AVAGO**  
TECHNOLOGIES

## Looking for pricing, stock, or lifecycle information?

Click below to explore more details on WIN SOURCE:

 [View MSA-0770 on WIN SOURCE](#)

 [Broadcom Limited](#) Information

## Optimize Your Supply Chain with WIN SOURCE Solutions

-  Global Sourcing Solution
-  Obsolete Management
-  Cost Control Management
-  Shortage Management
-  Alternative Solution
-  Excess Inventory Management