



THE DATASHEET OF MPC941AE



Low Voltage 1:27 Clock Distribution Chip

The MPC941 is a 1:27 low voltage clock distribution chip. The device features the capability to select either a differential LVPECL or an LVCMOS compatible input. The 27 outputs are LVCMOS compatible and feature the drive strength to drive 50Ω series or parallel terminated transmission lines. With output-to-output skews of 250ps, the MPC941 is ideal as a clock distribution chip for the most demanding of synchronous systems. For a similar product with a smaller number of outputs, please consult the MPC940 data sheet.

- LVPECL or LVCMOS Clock Input
- 250ps Maximum Output-to-Output Skew
- Drives Up to 54 Independent Clock Lines
- Maximum Output Frequency of 250MHz
- High Impedance Output Enable
- 48-Lead LQFP Packaging
- 3.3V or 2.5V V_{CC} Supply Voltage

With a low output impedance, in both the HIGH and LOW logic states, the output buffers of the MPC941 are ideal for driving series terminated transmission lines. More specifically, each of the 27 MPC941 outputs can drive two series terminated 50Ω transmission lines. With this capability, the MPC941 has an effective fanout of 1:54. With this level of fanout, the MPC941 provides enough copies of low skew clocks for most high performance synchronous systems.

The differential LVPECL inputs of the MPC941 allow the device to interface directly with an LVPECL fanout buffer like the MC100EP111 to build very wide clock fanout trees or to couple to a high frequency clock source. The LVCMOS input provides a more standard interface for applications requiring only a single clock distribution chip at relatively low frequencies. In addition, the two clock sources can be used as a test clock interface as well as the primary system clock. A logic HIGH on the LVCMOS_CLK_Sel pin will select the LVCMOS level clock input.

The MPC941 is fully 3.3V and 2.5V compatible. The 48-lead LQFP package was chosen to optimize performance, board space and cost of the device. The 48-lead LQFP has a 7x7mm body size.

MPC941

**LOW VOLTAGE 3.3V/2.5V
1:27 CLOCK
DISTRIBUTION CHIP**



FA SUFFIX
48-LEAD LQFP PACKAGE
CASE 932-02



LOGIC DIAGRAM

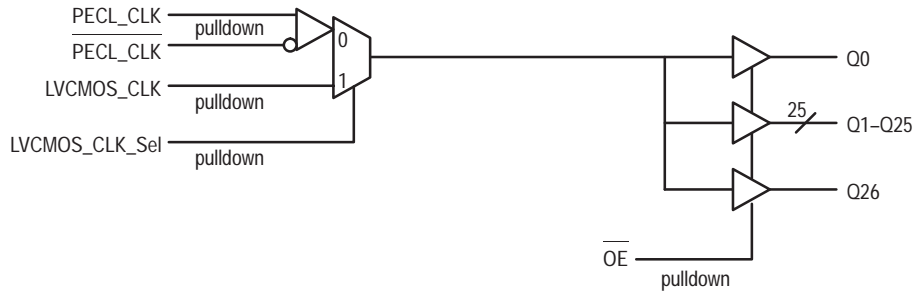

Pinout: 48-Lead QFP (Top View)

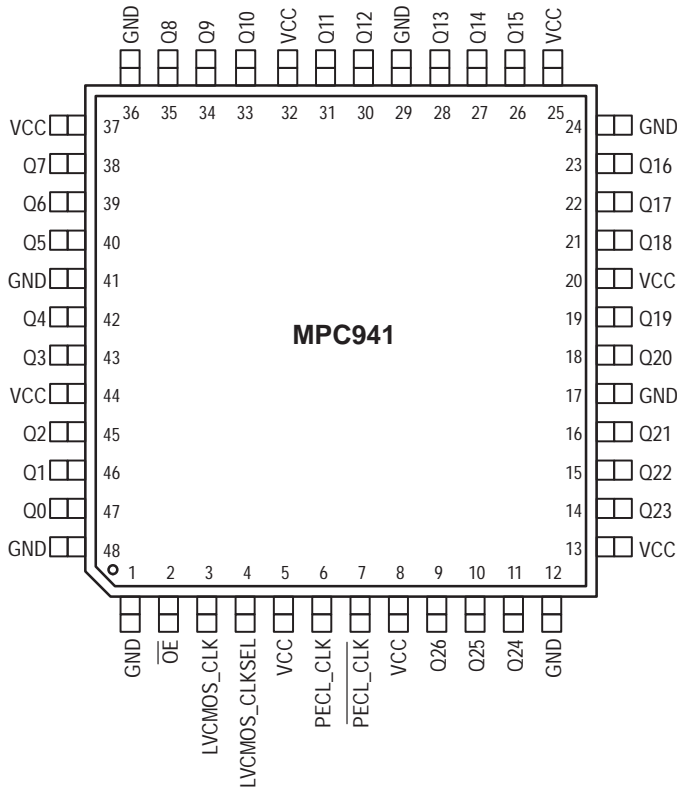

FUNCTION TABLE

LVC MOS_CLK_Sel	Input
0	PECL_CLK
1	LVC MOS_CLK

Table 1: PIN CONFIGURATIONS

Pin	I/O	Type	Function
PECL_CLK, PECL_CLK	Input	LVPECL	LVPECL differential reference clock inputs
LVC MOS_CLK	Input	LVC MOS	Alternative reference clock input
LVC MOS_CLK_Sel	Input	LVC MOS	Input reference clock select
OE	Input	LVC MOS	Output tristate control
GND		Supply	Negative voltage supply output bank (GND)
VCC		Supply	Positive voltage supply
Q0 - Q26	Output	LVC MOS	Clock outputs

Table 2: ABSOLUTE MAXIMUM RATINGS*

Symbol	Characteristics	Min	Max	Unit
V _{CC}	Supply Voltage	-0.3	3.6	V
V _{IN}	DC Input Voltage	-0.3	V _{CC} +0.3	V
V _{OUT}	DC Output Voltage	-0.3	V _{CC} +0.3	V
I _{IN}	DC Input Current		±20	mA
I _{OUT}	DC Output Current		±50	mA
T _S	Storage temperature	-40	125	°C

* Absolute maximum continuous ratings are those maximum values beyond which damage to the device may occur. Exposure to these conditions or conditions beyond those indicated may adversely affect device reliability. Functional operation under absolute-maximum-rated conditions is not implied.

Table 3: DC CHARACTERISTICS (V_{CC} = 3.3V ± 5%, T_A = -40 to +85°C)

Symbol	Characteristics	Min	Typ	Max	Unit	Condition
V _{IH}	Input high voltage LVC _{MOS} _CLK	2.0		V _{CC} + 0.3	V	LVC _{MOS}
V _{IL}	Input low voltage LVC _{MOS} _CLK	-0.3		0.8	V	LVC _{MOS}
I _{IN}	Input current			±120 ^a	µA	
V _{PP}	Peak-to-peak input voltage PECL_CLK, PECL_CLK	500			mV	LVPECL
V _{CMR}	Common Mode Range PECL_CLK, PECL_CLK	1.2		V _{CC} -0.8	V	LVPECL
V _{OH}	Output High Voltage	2.4			V	I _{OH} =-24 mA ^b
V _{OL}	Output Low Voltage			0.55 0.40	V V	I _{OL} = 24mA ^b I _{OL} =12mA
I _{OZ}	Output tristate leakage current			100	µA	
Z _{OUT}	Output impedance		14 - 17		Ω	
C _{PD}	Power Dissipation Capacitance		7-8	10	pF	Per Output
C _{IN}	Input capacitance		4.0		pF	
I _{CCQ}	Maximum Quiescent Supply Current			5	mA	All V _{CC} Pins
V _{TT}	Output termination voltage		V _{CC} +2		V	

- a. Input pull-up / pull-down resistors influence input current.
- b. The MPC941 is capable of driving 50Ω transmission lines on the incident edge. Each output drives one 50Ω parallel terminated transmission line to a termination voltage of V_{TT}. Alternatively, the device drives up to two 50Ω series terminated transmission lines.

Table 4: AC CHARACTERISTICS (V_{CC} = 3.3V ± 5%, T_A = -40 to +85°C)^a

Symbol	Characteristics	Min	Typ	Max	Unit	Condition
f _{MAX}	Maximum Output Frequency	0		250 ^b	MHz	
t _r , t _f	LVC _{MOS} _CLK Input Rise/Fall Time			1.0 ^c	ns	0.8 to 2.0V
t _{PLH} t _{PHL}	Propagation delay PECL_CLK to any Q LVC _{MOS} _CLK to any Q	1.2 0.9	1.8 1.5	2.6 2.3	ns ns	
t _{PLZ} , HZ	Output Disable Time				ns	
t _{PZL} , LZ	Output Enable Time				ns	
t _{sk(O)}	Output-to-output Skew PECL_CLK to any Q LVC _{MOS} _CLK to any Q		125 125	250 250	ps	
t _{sk(PP)}	Device-to-device Skew PECL_CLK to any Q LVC _{MOS} _CLK to any Q			1000 1000	ps ps	For a given T _A and V _{CC} , any Q
t _{sk(PP)}	Device-to-device Skew PECL_CLK to any Q LVC _{MOS} _CLK to any Q			1400 1400	ps ps	For any T _A , V _{CC} and Q
DCQ	Output Duty Cycle PECL_CLK to any Q LVC _{MOS} _CLK to any Q	45 45	50 50	60 55	% %	DC _{REF} = 50% DC _{REF} = 50%
t _r , t _f	Output Rise/Fall Time	0.2		1.0	ns	0.55 to 2.4V

- a. AC characteristics apply for parallel output termination of 50Ω to V_{TT}.
- b. AC characteristics are guaranteed up to f_{max}. Please refer to applications section for information on power consumption versus operating frequency and thermal management.
- c. Fast input signal transition times are required to maintain part-to-part skew specification. If part-to-part skew is not critical to the application, signal transition times smaller than 3 ns can be applied to the MPC941.

Freescale Semiconductor, Inc.

Table 5: DC CHARACTERISTICS ($V_{CC} = 2.5V \pm 5\%$, $T_A = -40$ to $+85^\circ C$)

Symbol	Characteristics	Min	Typ	Max	Unit	Condition
V_{IH}	Input high voltage LVC MOS_CLK	1.7		$V_{CC} + 0.3$	V	LVC MOS
V_{IL}	Input low voltage LVC MOS_CLK	-0.3		0.7	V	LVC MOS
I_{IN}	Input current			$\pm 120^a$	μA	
V_{PP}	Peak-to-peak input voltage PECL_CLK, PECL_CLK	500			mV	LVPECL
V_{CMR}	Common Mode Range PECL_CLK, PECL_CLK	1.1		$V_{CC}-0.7$	V	LVPECL
V_{OH}	Output High Voltage	1.8			V	$I_{OH} = -15 \text{ mA}^b$
V_{OL}	Output Low Voltage			0.6	V	$I_{OL} = 15 \text{ mA}^b$
I_{OZ}	Output tristate leakage current			100	μA	
Z_{OUT}	Output impedance		18 – 20		Ω	
C_{PD}	Power Dissipation Capacitance		7–8	10	pF	Per Output
C_{IN}	Input capacitance		4.0		pF	
I_{CCQ}	Maximum Quiescent Supply Current			5	mA	All V_{CC} Pins
V_{TT}	Output termination voltage		$V_{CC} \pm 2$		V	

- a. Input pull-up / pull-down resistors influence input current.
 b. The MPC941 is capable of driving 50Ω transmission lines on the incident edge. Each output drives one 50Ω parallel terminated transmission line to a termination voltage of V_{TT} . Alternatively, the device drives up to two 50Ω series terminated transmission lines.

Table 6: AC CHARACTERISTICS ($V_{CC} = 2.5V \pm 5\%$, $T_A = -40$ to $+85^\circ C$)^a

Symbol	Characteristics	Min	Typ	Max	Unit	Condition
f_{MAX}	Maximum Output Frequency	0		250^b	MHz	
t_r, t_f	LVC MOS_CLK Input Rise/Fall Time			1.0^c	ns	0.7 to 1.7V
t_{PLH} t_{PHL}	Propagation delay PECL_CLK to any Q LVC MOS_CLK to any Q	1.3 1.0	2.1 1.8	2.9 2.6	ns ns	
$t_{PLZ, HZ}$	Output Disable Time				ns	
$t_{PZL, LZ}$	Output Enable Time				ns	
$t_{sk(O)}$	Output-to-output Skew PECL_CLK to any Q LVC MOS_CLK to any Q		125 125	250 250	ps	
$t_{sk(PP)}$	Device-to-device Skew PECL_CLK to any Q LVC MOS_CLK to any Q			1200 1200	ps ps	For a given T_A and V_{CC} , any Q
$t_{sk(PP)}$	Device-to-device Skew PECL_CLK to any Q LVC MOS_CLK to any Q			1600 1600	ps ps	For any T_A , V_{CC} and Q
DCQ	Output Duty Cycle PECL_CLK to any Q LVC MOS_CLK to any Q	45 45	50 50	60 55	% %	$DC_{REF} = 50\%$ $DC_{REF} = 50\%$
t_r, t_f	Output Rise/Fall Time			1.0	ns	0.6 to 1.6V

- a. AC characteristics apply for parallel output termination of 50Ω to V_{TT} .
 b. AC characteristics are guaranteed up to f_{max} . Please refer to the applications section for information on power consumption versus operating frequency and thermal management.
 c. Fast input signal transition times are required to maintain part-to-part skew specification. If part-to-part skew is not critical to the application, signal transition times smaller than 3 ns can be applied to the MPC941.

APPLICATIONS INFORMATION

Driving Transmission Lines

The MPC941 clock driver was designed to drive high speed signals in a terminated transmission line environment. To provide the optimum flexibility to the user the output drivers were designed to exhibit the lowest impedance possible. With an output impedance of less than 20Ω the drivers can drive either parallel or series terminated transmission lines. For more information on transmission lines the reader is referred to application note AN1091 in the Timing Solutions data book (DL207/D).

In most high performance clock networks point-to-point distribution of signals is the method of choice. In a point-to-point scheme either series terminated or parallel terminated transmission lines can be used. The parallel technique terminates the signal at the end of the line with a 50Ω resistance to VCC/2. This technique draws a fairly high level of DC current and thus only a single terminated line can be driven by each output of the MPC941 clock driver. For the series terminated case however there is no DC current draw, thus the outputs can drive multiple series terminated lines. Figure 1 “Single versus Dual Transmission Lines” illustrates an output driving a single series terminated line vs two series terminated lines in parallel. When taken to its extreme the fanout of the MPC941 clock driver is effectively doubled due to its capability to drive multiple lines.

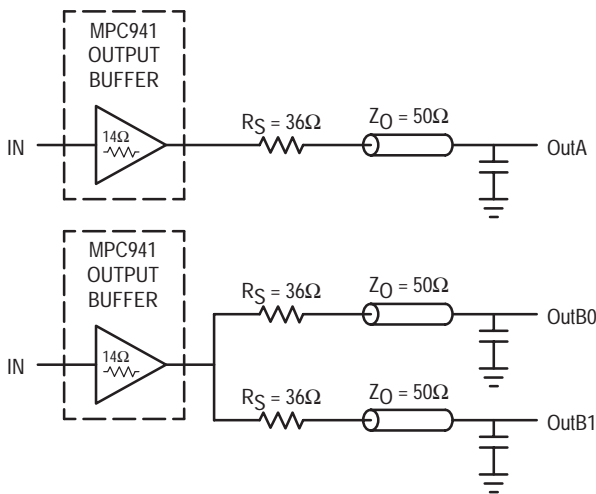

Figure 1. Single versus Dual Transmission Lines

The waveform plots of Figure 2 “Single versus Dual Waveforms” show the simulation results of an output driving a single line vs two lines. In both cases the drive capability of the MPC941 output buffer is more than sufficient to drive 50Ω transmission lines on the incident edge. Note from the delay measurements in the simulations a delta of only 43ps exists between the two differently loaded outputs. This suggests that the dual line driving need not be used exclusively to maintain the tight output-to-output skew of the MPC941. The output waveform in Figure 2 shows a step in the waveform, this step is caused by the impedance mismatch seen looking into the driver. The parallel combination of the 36Ω series resistor plus the output impedance does not

match the parallel combination of the line impedances. The voltage wave launched down the two lines will equal:

$$V_L = V_S (Z_o / (R_s + R_o + Z_o))$$

$$Z_o = 50\Omega \parallel 50\Omega$$

$$R_s = 36\Omega \parallel 36\Omega$$

$$R_o = 14\Omega$$

$$V_L = 3.0 (25 / (18 + 14 + 25)) = 3.0 (25 / 57)$$

$$= 1.31V$$

At the load end the voltage will double, due to the near unity reflection coefficient, to 2.5V. It will then increment towards the quiescent 3.0V in steps separated by one round trip delay (in this case 4.0ns).

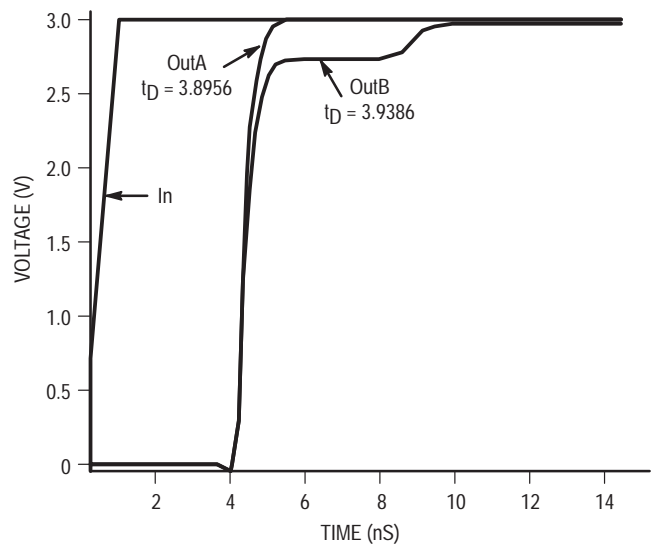

Figure 2. Single versus Dual Waveforms

Since this step is well above the threshold region it will not cause any false clock triggering, however designers may be uncomfortable with unwanted reflections on the line. To better match the impedances when driving multiple lines the situation in Figure 3 “Optimized Dual Line Termination” should be used. In this case the series terminating resistors are reduced such that when the parallel combination is added to the output buffer impedance the line impedance is perfectly matched.

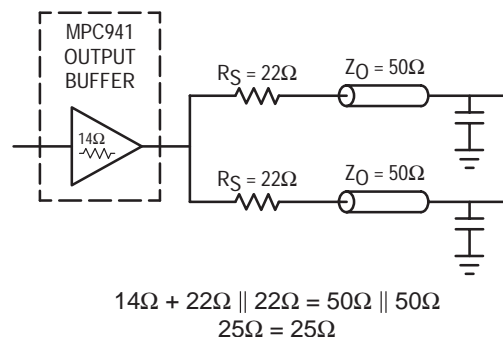

Figure 3. Optimized Dual Line Termination

Power Consumption of the MPC941 and Thermal Management

The MPC941 AC specification is guaranteed for the entire operating frequency range up to 250 MHz. The MPC941 power consumption and the associated long-term reliability may decrease the maximum frequency limit, depending on operating conditions such as clock frequency, supply voltage, output loading, ambient temperature, vertical convection and thermal conductivity of package and board. This section describes the impact of these parameters on the junction temperature and gives a guideline to estimate the MPC941 die junction temperature and the associated device reliability. For a complete analysis of power consumption as a function of operating conditions and associated long term device reliability please refer to the application note AN1545. According to the AN1545, the long-term device reliability is a function of the die junction temperature:

Table 7: Die junction temperature and MTBF

Junction temperature (°C)	MTBF (Years)
100	20.4
110	9.1
120	4.2
130	2.0

Increased power consumption will increase the die junction temperature and impact the device reliability (MTBF). According to the system-defined tolerable MTBF, the die junction temperature of the MPC941 needs to be controlled and the thermal impedance of the board/package should be optimized. The power dissipated in the MPC941 is represented in equation 1.

Where I_{CCQ} is the static current consumption of the MPC941, C_{PD} is the power dissipation capacitance per output, $(M)\Sigma C_L$ represents the external capacitive output load, N is the number of active outputs (N is always 27 in case of the MPC941). The MPC941 supports driving transmission lines to maintain high signal integrity and tight timing parameters. Any transmission line will hide the lumped capacitive load at the end of the board trace, therefore, ΣC_L is zero for controlled transmission line systems and can be eliminated from equation 1. Using parallel termination output termination results in equation 2 for power dissipation.

$$P_{TOT} = \left[I_{CCQ} + V_{CC} \cdot f_{CLOCK} \cdot \left(N \cdot C_{PD} + \sum_M C_L \right) \right] \cdot V_{CC} \quad \text{Equation 1}$$

$$P_{TOT} = V_{CC} \cdot \left[I_{CCQ} + V_{CC} \cdot f_{CLOCK} \cdot \left(N \cdot C_{PD} + \sum_M C_L \right) \right] + \sum_P [DC_Q \cdot I_{OH} \cdot (V_{CC} - V_{OH}) + (1 - DC_Q) \cdot I_{OL} \cdot V_{OL}] \quad \text{Equation 2}$$

$$T_J = T_A + P_{TOT} \cdot R_{thja} \quad \text{Equation 3}$$

$$f_{CLOCK,MAX} = \frac{1}{C_{PD} \cdot N \cdot V_{CC}^2} \cdot \left[\frac{T_{J,MAX} - T_A}{R_{thja}} - (I_{CCQ} \cdot V_{CC}) \right] \quad \text{Equation 4}$$

In equation 2, P stands for the number of outputs with a parallel or thevenin termination, V_{OL} , I_{OL} , V_{OH} and I_{OH} are a function of the output termination technique and DC_Q is the clock signal duty cycle. If transmission lines are used ΣC_L is zero in equation 2 and can be eliminated. In general, the use of controlled transmission line techniques eliminates the impact of the lumped capacitive loads at the end lines and greatly reduces the power dissipation of the device. Equation 3 describes the die junction temperature T_J as a function of the power consumption.

Where R_{thja} is the thermal impedance of the package (junction to ambient) and T_A is the ambient temperature. According to Table 7, the junction temperature can be used to estimate the long-term device reliability. Further, combining equation 1 and equation 2 results in a maximum operating frequency for the MPC941 in a series terminated transmission line system.

$T_{J,MAX}$ should be selected according to the MTBF system requirements and Table 7. R_{thja} can be derived from Table 8. The R_{thja} represent data based on 1S2P boards, using 2S2P boards will result in a lower thermal impedance than indicated below.

Table 8: Thermal package impedance of the 48ld LQFP

Convection, LFPM	R_{thja} (1P2S board), K/W
Still air	78
100 lfpm	68
200 lfpm	59
300 lfpm	56
400 lfpm	54
500 lfpm	53

If the calculated maximum frequency is below 250 MHz, it becomes the upper clock speed limit for the given application conditions. The following eight derating charts describe the safe frequency operation range for the MPC941. The charts were calculated for a maximum tolerable die junction temperature of 110°C (120°C), corresponding to a estimated MTBF of 9.1 years (4 years), a supply voltage of either 3.3V or 2.5V and series terminated transmission line or capacitive loading. Depending on a given set of these operating conditions and the available device convection a decision on the maximum operating frequency can be made.

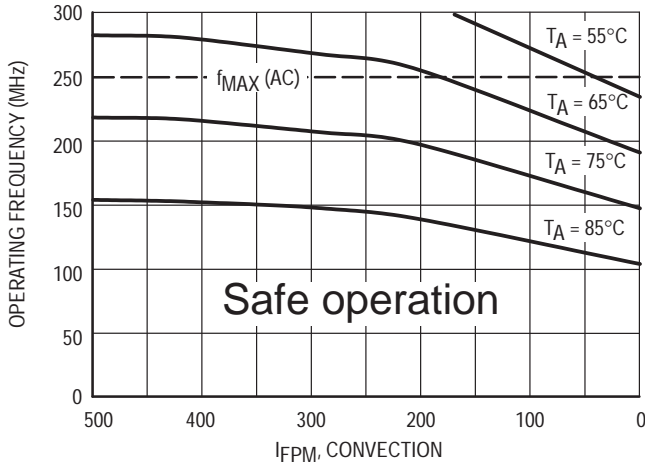

Figure 4. Maximum MPC941 frequency, $V_{CC} = 3.3V$, MTBF 9.1 years, driving series terminated transmission lines

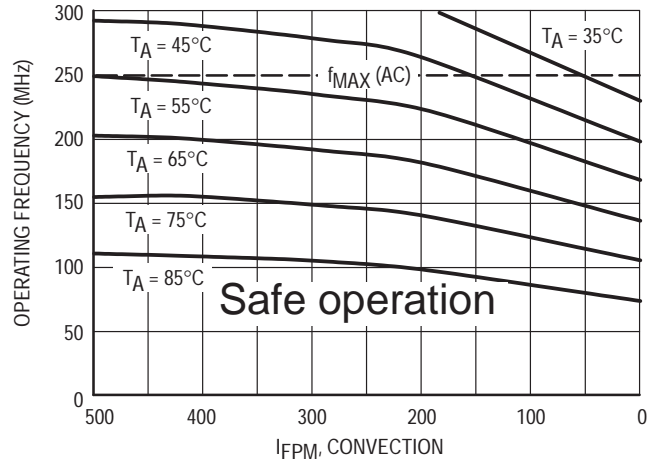

Figure 5. Maximum MPC941 frequency, $V_{CC} = 3.3V$, MTBF 9.1 years, 4 pF load per line

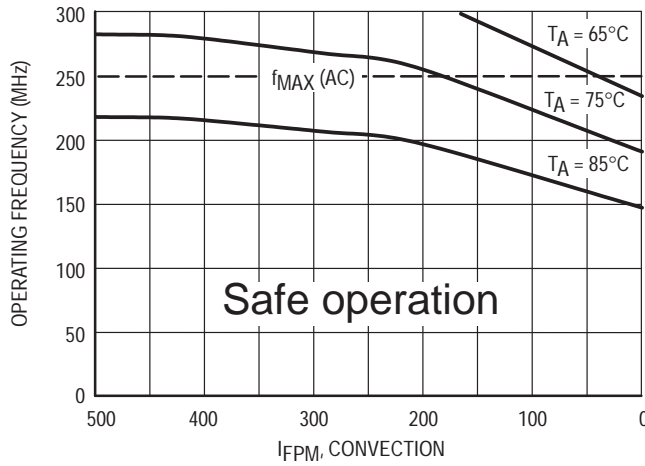

Figure 6. Maximum MPC941 frequency, $V_{CC} = 3.3V$, MTBF 4 years, driving series terminated transmission lines

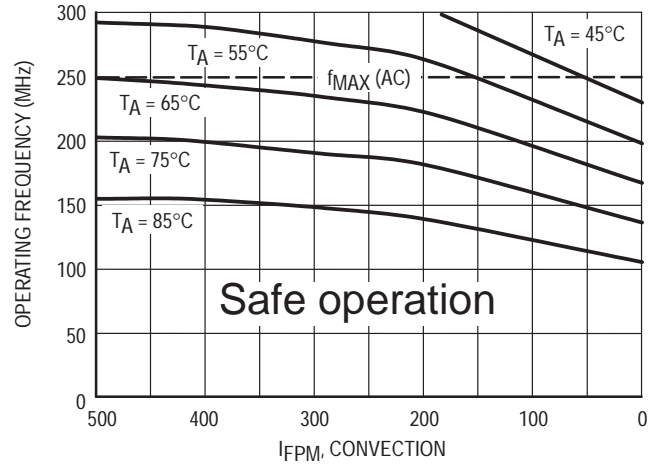

Figure 7. Maximum MPC941 frequency, $V_{CC} = 3.3V$, MTBF 4 years, 4 pF load per line

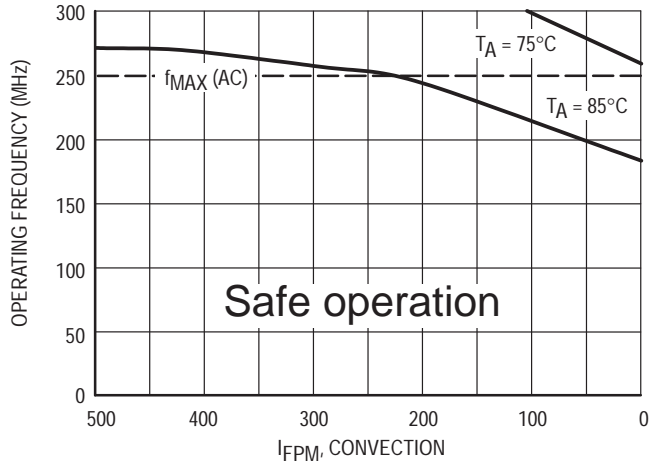

Figure 8. Maximum MPC941 frequency, $V_{CC} = 2.5V$, MTBF 9.1 years, driving series terminated transmission lines

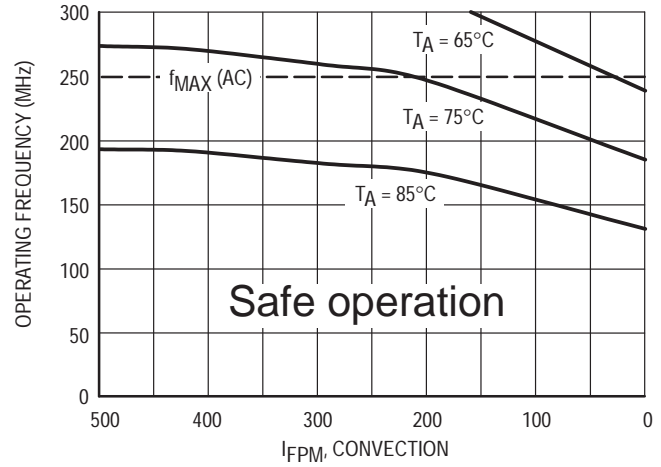

Figure 9. Maximum MPC941 frequency, $V_{CC} = 2.5V$, MTBF 9.1 years, 4 pF load per line

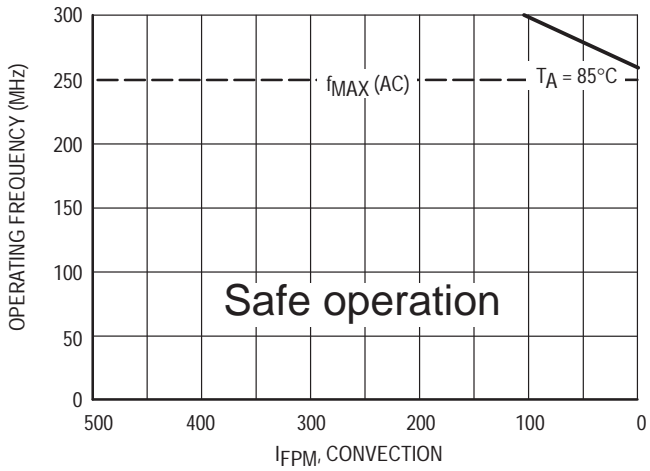

Figure 10. Maximum MPC941 frequency, $V_{CC} = 2.5V$, MTBF 4 years, driving series terminated transmission lines

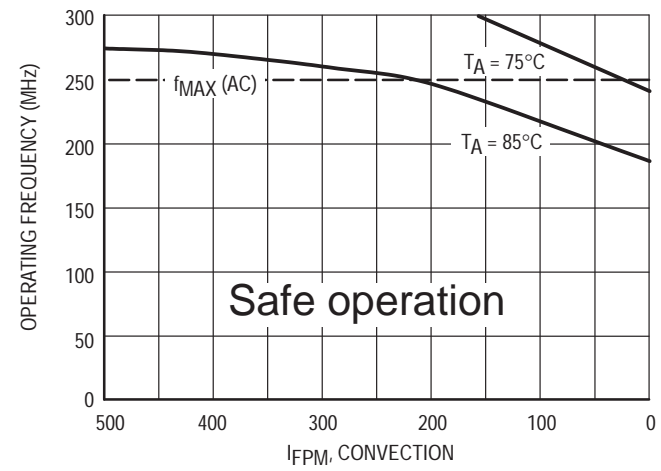

Figure 11. Maximum MPC941 frequency, $V_{CC} = 2.5V$, MTBF 4 years, 4 pF load per line

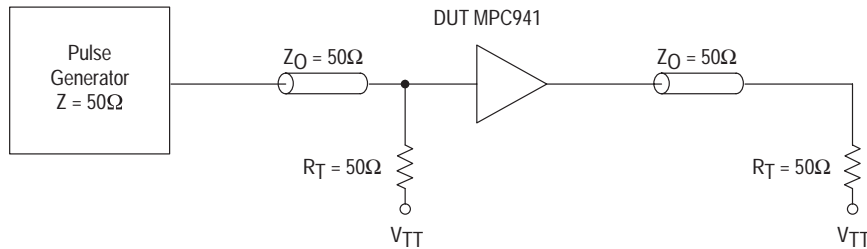

Figure 12. LVC MOS_CLK MPC941 AC test reference for $V_{CC} = 3.3V$ and $V_{CC} = 2.5V$

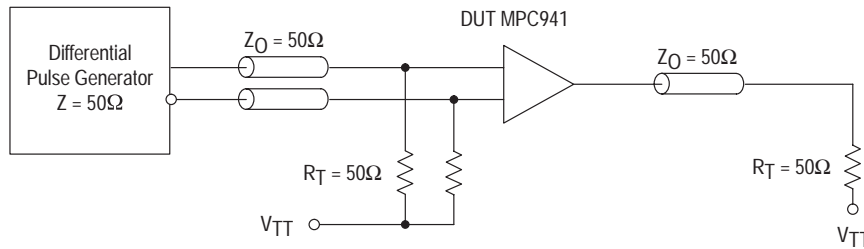

Figure 13. PECL_CLK MPC941 AC test reference for $V_{CC} = 3.3V$ and $V_{CC} = 2.5V$

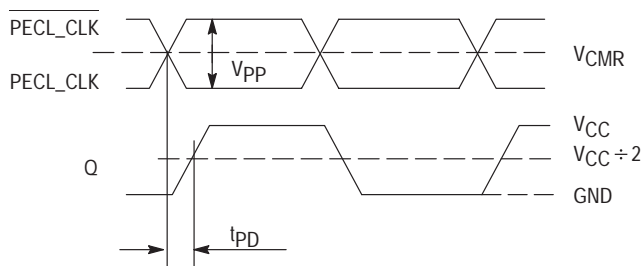

Figure 14. LVPECL Propagation delay (t_{pD}) test reference

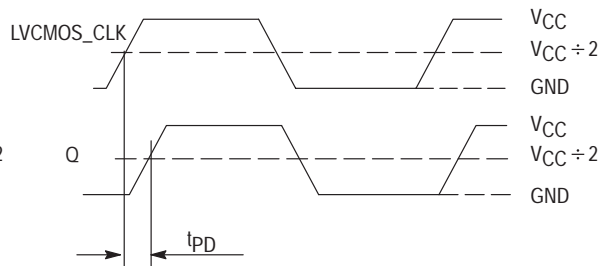
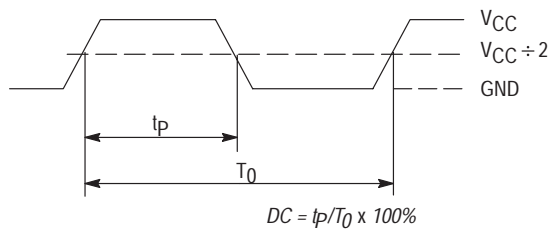
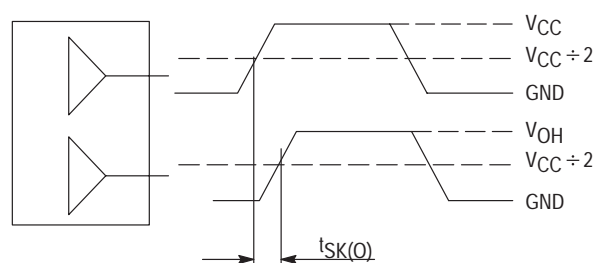

Figure 15. LVC MOS Propagation delay (t_{pD}) test reference



The time from the PLL controlled edge to the non controlled edge, divided by the time between PLL controlled edges, expressed as a percentage

Figure 16. Output Duty Cycle (DC)



The pin-to-pin skew is defined as the worst case difference in propagation delay between any two similar delay paths within a single device

Figure 17. Output-to-output Skew $t_{SK(O)}$

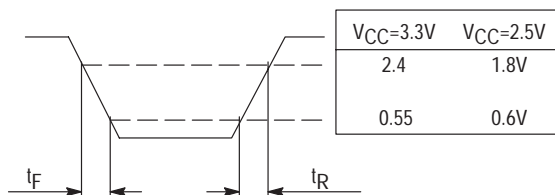

Figure 18. Output Transition Time Test Reference

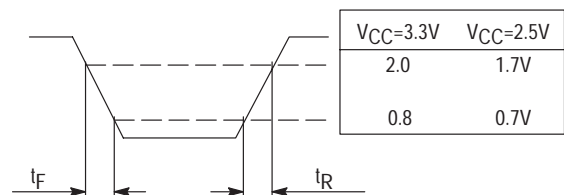
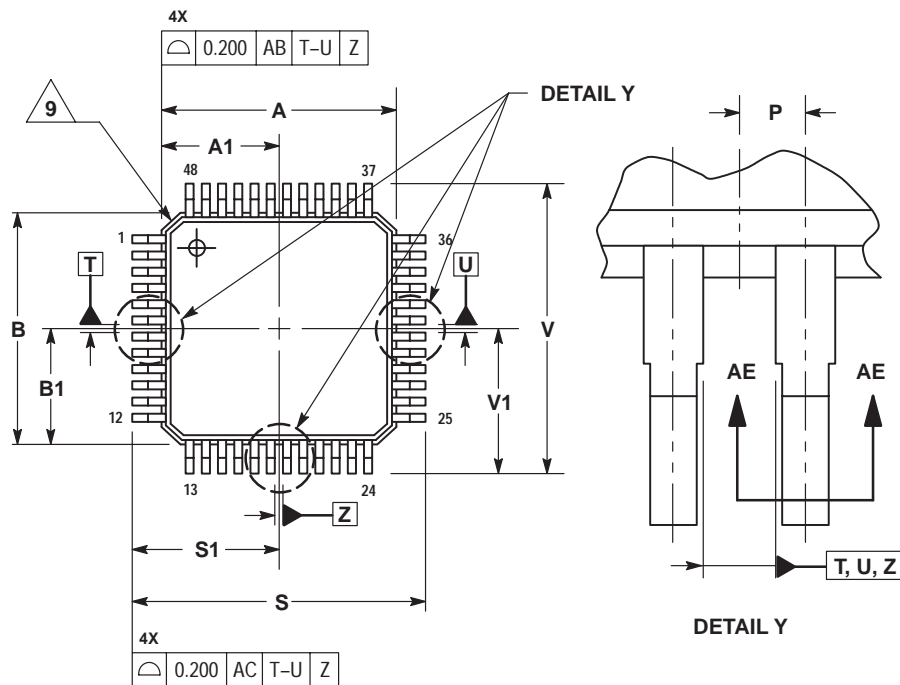

Figure 19. Input Transition Time Test Reference

OUTLINE DIMENSIONS

FA SUFFIX
PLASTIC QFP PACKAGE
CASE 932-02
ISSUE E



- NOTES:
1. DIMENSIONING AND TOLERANCING PER ASME Y14.5M, 1994.
 2. CONTROLLING DIMENSION: MILLIMETER.
 3. DATUM PLANE AB IS LOCATED AT BOTTOM OF LEAD AND IS COINCIDENT WITH THE LEAD WHERE THE LEAD EXITS THE PLASTIC BODY AT THE BOTTOM OF THE PARTING LINE.
 4. DATUMS T, U, AND Z TO BE DETERMINED AT DATUM PLANE AB.
 5. DIMENSIONS S AND V TO BE DETERMINED AT SEATING PLANE AC.
 6. DIMENSIONS A AND B DO NOT INCLUDE MOLD PROTRUSION. ALLOWABLE PROTRUSION IS 0.250 PER SIDE. DIMENSIONS A AND B DO INCLUDE MOLD MISMATCH AND ARE DETERMINED AT DATUM PLANE AB.
 7. DIMENSION D DOES NOT INCLUDE DAMBAR PROTRUSION. DAMBAR PROTRUSION SHALL NOT CAUSE THE D DIMENSION TO EXCEED 0.350.
 8. MINIMUM SOLDER PLATE THICKNESS SHALL BE 0.0076.
 9. EXACT SHAPE OF EACH CORNER IS OPTIONAL.

MILLIMETERS		
DIM	MIN	MAX
A	7.000	BSC
A1	3.500	BSC
B	7.000	BSC
B1	3.500	BSC
C	1.400	1.600
D	0.170	0.270
E	1.350	1.450
F	0.170	0.230
G	0.500	BSC
H	0.050	0.150
J	0.090	0.200
K	0.500	0.700
L	1°	5°
M	12°	REF
N	0.090	0.160
P	0.250	BSC
R	0.150	0.250
S	9.000	BSC
S1	4.500	BSC
V	9.000	BSC
V1	4.500	BSC
W	0.200	REF
AA	1.000	REF

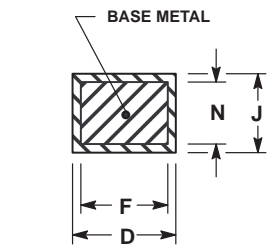
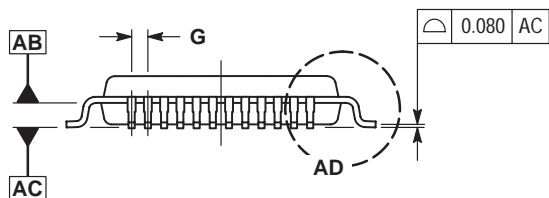

SECTION AE-AE
 0.080 (M) AC T-U Z

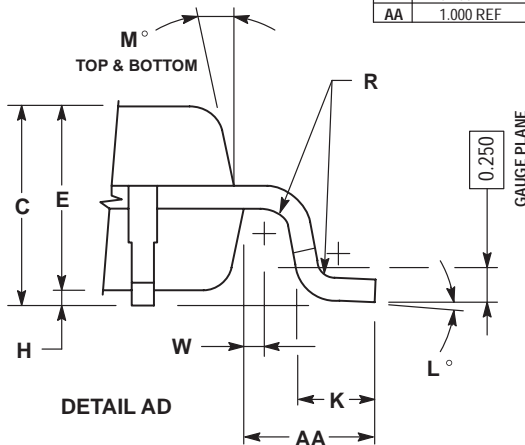

NOTES

Freescale Semiconductor, Inc.

Motorola reserves the right to make changes without further notice to any products herein. Motorola makes no warranty, representation or guarantee regarding the suitability of its products for any particular purpose, nor does Motorola assume any liability arising out of the application or use of any product or circuit, and specifically disclaims any and all liability, including without limitation consequential or incidental damages. "Typical" parameters which may be provided in Motorola data sheets and/or specifications can and do vary in different applications and actual performance may vary over time. All operating parameters, including "Typicals" must be validated for each customer application by customer's technical experts. Motorola does not convey any license under its patent rights nor the rights of others. Motorola products are not designed, intended, or authorized for use as components in systems intended for surgical implant into the body, or other applications intended to support or sustain life, or for any other application in which the failure of the Motorola product could create a situation where personal injury or death may occur. Should Buyer purchase or use Motorola products for any such unintended or unauthorized application, Buyer shall indemnify and hold Motorola and its officers, employees, subsidiaries, affiliates, and distributors harmless against all claims, costs, damages, and expenses, and reasonable attorney fees arising out of, directly or indirectly, any claim of personal injury or death associated with such unintended or unauthorized use, even if such claim alleges that Motorola was negligent regarding the design or manufacture of the part. Motorola and  are registered trademarks of Motorola, Inc. Motorola, Inc. is an Equal Opportunity/Affirmative Action Employer.

How to reach us:

USA/EUROPE/Locations Not Listed: Motorola Literature Distribution;
P.O. Box 5405, Denver, Colorado 80217. 1-303-675-2140 or 1-800-441-2447

JAPAN: Motorola Japan Ltd.; SPS, Technical Information Center, 3-20-1,
Minami-Azabu, Minato-ku, Tokyo 106-8573 Japan. 81-3-3440-3569

Technical Information Center: 1-800-521-6274

ASIA/PACIFIC: Motorola Semiconductors H.K. Ltd.; Silicon Harbour Centre,
2, Dai King Street, Tai Po Industrial Estate, Tai Po, N.T., Hong Kong.
852-26668334

HOME PAGE: <http://www.motorola.com/semiconductors/>



**For More Information On This Product,
Go to: www.freescale.com**

MPC941/D
DLZ01 REV 0

Looking for pricing, stock, or lifecycle information?

Click below to explore more details on WIN SOURCE:

 [View MPC941AE on WIN SOURCE](#)

 [NXP / Nexperia Information](#)

Optimize Your Supply Chain with WIN SOURCE Solutions

-  Global Sourcing Solution
-  Obsolete Management
-  Cost Control Management
-  Shortage Management
-  Alternative Solution
-  Excess Inventory Management