

|                 |  |
|-----------------|--|
| STRUCTURE       | Silicon Monolithic Integrated Circuit  |
| NAME OF PRODUCT | DC-AC Inverter Control IC  |
| TYPE            | <b>BD9898F、BD9898FV</b>  |
| FUNCTION        | <ul style="list-style-type: none"> <li>▪ 36V High voltage process</li> <li>▪ 1ch control with Full-Bridge</li> <li>▪ Lamp current and voltage sense feed back control</li> <li>▪ Sequencing easily achieved with Soft Start Control</li> <li>▪ Short circuit protection with Timer Latch</li> <li>▪ Under Voltage Lock Out</li> <li>▪ Mode-selectable the operating or stand-by mode by stand-by pin</li> <li>▪ For slave IC, Synchronous operating with BD9215F/FV</li> <li>▪ BURST mode controlled by PWM and DC input</li> <li>▪ Output liner Control by external DC voltage</li> </ul> |

○Absolute Maximum Ratings (Ta = 25°C)

| Parameter                    | Symbol | Limits            | Unit |
|------------------------------|--------|-------------------|------|
| Supply Voltage               | Vcc    | 36                | V    |
| BST pin                      | BST    | 40                | V    |
| SW pin                       | SW     | 36                | V    |
| BST-SW voltage difference    | BST-SW | 15                | V    |
| Operating Temperature Range  | Topr   | -40~+85           | °C   |
| Storage Temperature Range    | Tstg   | -55~+150          | °C   |
| Maximum Junction Temperature | Tjmax  | +150              | °C   |
| Power Dissipation            | Pd     | 749*1 (BD9898F)   | mW   |
|                              |        | 1062*2 (BD9898FV) |      |

\*1Pd derate at 6.0mW/°C for temperature above Ta = 25°C (When mounted on a PCB 70.0mm×70.0mm×1.6mm)

\*2Pd derate at 8.5mW/°C for temperature above Ta = 25°C (When mounted on a PCB 70.0mm×70.0mm×1.6mm)

○Operating condition

| Parameter                 | Symbol | Limits      | Unit |
|---------------------------|--------|-------------|------|
| Supply voltage            | Vcc    | 16.0~30.0 ※ | V    |
| BST voltage               | BST    | 5.0~37.5    | V    |
| BST-SW voltage difference | BST-SW | 5.0~14.0    | V    |
| DRIVER frequency          | FOUT   | 30~110      | kHz  |
| BCT oscillation frequency | fBCT   | 0.05~1.00   | kHz  |

※For Operation condition of Supply voltage, Please see NOTE FOR USE(4page), more information.

Status of this document

The Japanese version of this document is the official specification.

Please use the translation version of this document as a reference to expedite understanding of the official version.

If there are any uncertainty in translation version of this document, official version takes priority.

## ○Electric Characteristics (Ta=25°C, VCC=24V, STB=UVLO=3.0V)

| Parameter                        | Symbol           | Limits   |         |          | Unit | Conditions                   |
|----------------------------------|------------------|----------|---------|----------|------|------------------------------|
|                                  |                  | MIN.     | TYP.    | MAX.     |      |                              |
| ((WHOLE DEVICE))                 |                  |          |         |          |      |                              |
| Operating current                | Icc1             | —        | 5.5     | 10       | mA   | FOUT=60kHz, FB=GND, BST=OPEN |
| Stand-by current                 | Icc2             | —        | 60      | 140      | μA   |                              |
| ((STAND BY CONTROL))             |                  |          |         |          |      |                              |
| Stand-by voltage H               | VstH             | 2        | —       | VCC      | V    | System ON                    |
| Stand-by voltage L               | VstL             | -0.3     | —       | 0.8      | V    | System OFF                   |
| ((UVLO BLOCK))                   |                  |          |         |          |      |                              |
| Operating voltage (UVLO)         | Vuvlo            | 2.16     | 2.25    | 2.34     | V    |                              |
| Hysteresis width (UVLO)          | $\Delta$ Vuvlo   | 0.085    | 0.110   | 0.135    | V    |                              |
| ((REG BLOCK))                    |                  |          |         |          |      |                              |
| REG output voltage               | VREG             | 7.35     | 7.50    | 7.65     | V    |                              |
| REG source current               | IREG             | 20       | —       | —        | mA   |                              |
| ((OSC BLOCK))                    |                  |          |         |          |      |                              |
| RT pin Voltage                   | VRT              | 1.05     | 1.50    | 1.95     | V    |                              |
| Soft start current               | ISS              | 1.7      | 2.2     | 2.7      | μA   |                              |
| SS operation start Voltage       | VSS_ST           | 0.18     | 0.20    | 0.22     | V    |                              |
| SS term END Voltage              | VSS_ED           | 1.35     | 1.50    | 1.65     | V    |                              |
| SRT ON resistance                | RSRT             | —        | 85      | 170      | Ω    |                              |
| ((BOSC BLOCK))                   |                  |          |         |          |      |                              |
| BOSC Max voltage                 | VBCTH            | 1.94     | 2       | 2.06     | V    | fBCT=0.3kHz                  |
| BOSC Min voltage                 | VBCTL            | 0.4      | 0.5     | 0.6      | V    | fBCT=0.3kHz                  |
| BOSC constant current            | IBCT             | 1.35/BRT | 1.5/BRT | 1.65/BRT | A    | VBCT=0.2V                    |
| BOSC frequency                   | fBCT             | 291      | 300     | 309      | Hz   | (BRT=37.8kΩ BCT=0.047μF)     |
| ((FEED BACK BLOCK))              |                  |          |         |          |      |                              |
| IS threshold voltage 1           | VIS1             | 1.225    | 1.25    | 1.275    | V    |                              |
| IS threshold voltage 2           | VIS2             | —        | VREFIN  | VIS1     | V    | VREF applying voltage        |
| VS threshold voltage             | VVS              | 1.22     | 1.25    | 1.28     | V    |                              |
| IS source current 1              | IIS1             | —        | —       | 0.9      | μA   | DUTY=2.2V                    |
| IS source current 2              | IIS2             | 40       | 50      | 60       | μA   | DUTY=0V IS=1.0V              |
| VS source current                | IVS              | —        | —       | 0.9      | μA   |                              |
| IS COMP detect voltage 1         | VISCOMP1         | 0.606    | 0.625   | 0.644    | V    | VREFIN ≥ 1.25V               |
| IS COMP detect voltage 2         | VISCOMP2         | —        | 0.50    | —        | V    | VREFIN= 1V                   |
| VREF input voltage range         | VREFIN           | 0.6      | —       | 1.6      | V    | No effect at VREF > 1.25V    |
| ((OUTPUT BLOCK))                 |                  |          |         |          |      |                              |
| LN output sink resistance        | RsinkLN          | 1.8      | 3.5     | 7.0      | Ω    |                              |
| LN output source resistance      | RsourceLN        | 4.5      | 9.0     | 18.0     | Ω    |                              |
| HN output sink resistance        | RsinkHN          | 1.8      | 3.5     | 7.0      | Ω    | VBST-VSW=7.0V                |
| HN output source resistance      | RsourceLN        | 4.5      | 9.0     | 18.0     | Ω    | VBST-VSW=7.0V                |
| MAX DUTY                         | MAX DUTY         | 46.0     | 48.5    | 49.5     | %    | FOUT=60kHz                   |
| OFF period                       | TOFF             | 100      | 200     | 400      | ns   |                              |
| Drive output frequency           | FOUT             | 57.9     | 60      | 62.1     | kHz  | RT=21kΩ                      |
| ((TIMER LATCH BLOCK))            |                  |          |         |          |      |                              |
| Timer Latch setting voltage      | VCP              | 3.88     | 4.0     | 4.12     | V    |                              |
| Timer Latch setting current      | ICP              | 1.6      | 2.1     | 2.6      | μA   |                              |
| ((COMP BLOCK))                   |                  |          |         |          |      |                              |
| COMP over voltage detect voltage | VCOMPH           | 3.88     | 4.0     | 4.12     | V    | VSS > 1.65V                  |
| Hysteresis width (COMP)          | $\Delta$ VCOMPH  | 0.15     | 0.20    | 0.25     | V    |                              |
| ((Synchronous Block))            |                  |          |         |          |      |                              |
| High voltage                     | VCT_SYNC         | 3.8      | 4.0     | 4.2      | V    |                              |
| Low voltage                      | VCT_SYNC_L       | —        | —       | 0.5      | V    |                              |
| CT_SYNC_OUT sink resistance      | RSYNC_OUT_sink   | —        | 150     | 300      | Ω    |                              |
| CT_SYNC_OUT source resistance    | RSYNC_OUT_source | —        | 300     | 400      | Ω    |                              |
| High voltage input range         | VCT_SYNC_IN_H    | 2.5      | —       | VCT_SYNC | V    |                              |
| Low voltage input range          | VCT_SYNC_IN_L    | -0.3     | —       | 1        | V    |                              |

(This product is not designed to be radiation-resistant.)

○Package Dimensions

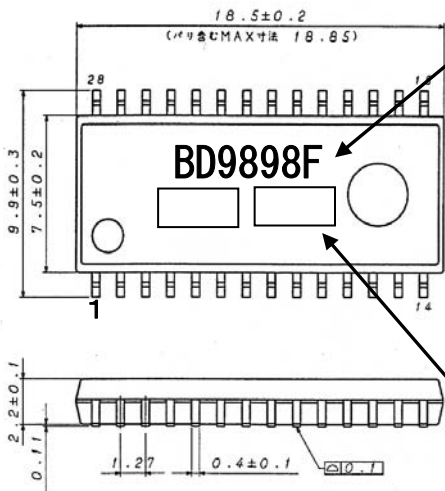

SOP28 (Unit:mm)

Device Mark

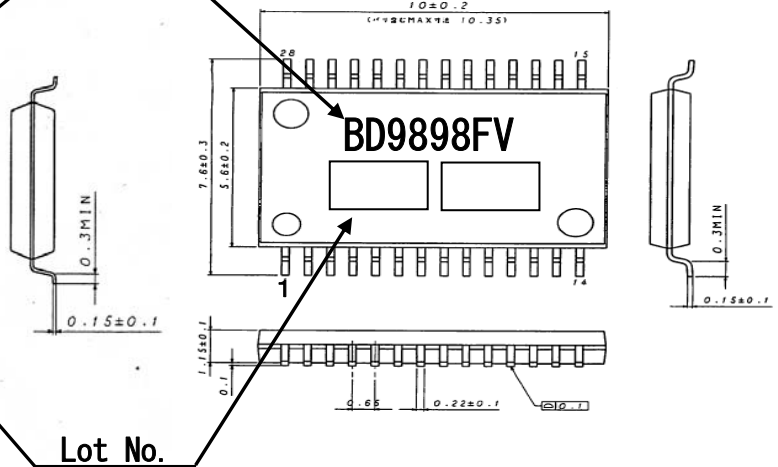

SSOP-B28 (Unit:mm)

Lot No.

○Block Diagram

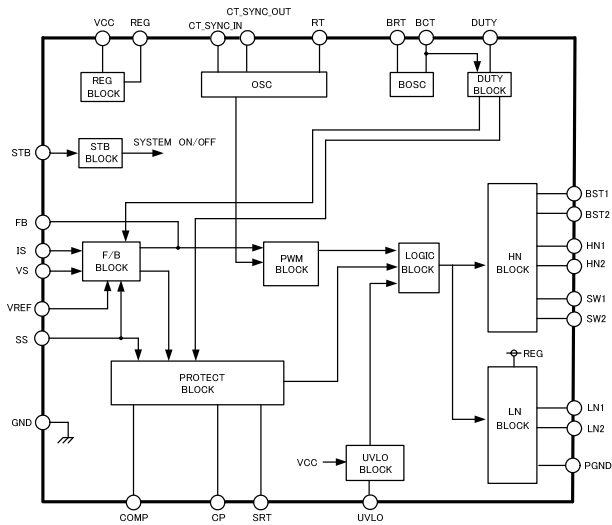

○Pin Description

| PIN No. | PIN NAME    | FUNCTION  |
|---------|-------------|---|
| 1       | PGND        | Ground for FET drivers  |
| 2       | LN2         | NMOS FET driver   |
| 3       | HN2         | NMOS FET driver   |
| 4       | SW2         | Lower rail voltage for HN2 output   |
| 5       | BST2        | Boot-Strap input for HN2 output   |
| 6       | CT_SYNC_IN  | CT synchronous signal input pin   |
| 7       | CT_SYNC_OUT | CT synchronous signal output pin  |
| 8       | SRT         | External resistor from SRT to RT for adjusting the start-up triangle oscillator |
| 9       | RT          | External resistor from RT to GND for adjusting the triangle oscillator          |
| 10      | GND         | GROUND  |
| 11      | BCT         | External capacitor from BCT to GND for adjusting the BURST triangle oscillator  |
| 12      | BRT         | External resistor from BRT to GND for adjusting the BURST triangle oscillator   |
| 13      | DUTY        | Control PWM mode and BURST mode   |
| 14      | STB         | Stand-by switch   |
| 15      | CP          | External capacitor from CP to GND for Timer Latch                               |
| 16      | VREF        | Reference voltage input pin for Error amplifier                                 |
| 17      | VS          | Error amplifier input   |
| 18      | IS          | Error amplifier input   |
| 19      | FB          | Error amplifier output  |
| 20      | SS          | External capacitor from SS to GND for Soft Start Control                        |
| 21      | COMP        | Over voltage detect pin   |
| 22      | VCC         | Supply voltage input  |
| 23      | UVLO        | External Under Voltage Lock Out   |
| 24      | REG         | Internal regulator output   |
| 25      | BST1        | Boot-Strap input for HN1 output   |
| 26      | SW1         | Lower rail voltage for HN1 output   |
| 27      | HN1         | NMOS FET driver   |
| 28      | LN1         | NMOS FET driver   |

○NOTE FOR USE

1. This product is produced with strict quality control, but might be destroyed if used beyond its absolute maximum ratings. Once IC is destroyed, failure mode will be difficult to determine, like short mode or open mode. Therefore, physical protection countermeasure, like fuse is recommended in case operating conditions go beyond the expected absolute maximum ratings.
2. The circuit functionality is guaranteed within of ambient temperature operation range as long as it is within recommended operating range. The standard electrical characteristic values cannot be guaranteed at other voltages in the operating ranges, however the variation will be small. When it is used in between STB-UVLO Diode short etc., the IC can operate  $V_{CC} \geq 9V$ . Please refer to a Technical Note in detail.
3. Mounting failures, such as misdirection or miscounts, may harm the device.
4. A strong electromagnetic field may cause the IC to malfunction.
5. The GND pin should be the location within  $\pm 0.3V$  compared with the PGND pin. ALL Pin (except BST1, BST2, HN1, HN2,) Voltage should be under  $V_{CC}$  voltage +0.3V
6. BD9898F, BD9898FV incorporate a built-in thermal shutdown circuit (TSD circuit). The thermal shutdown circuit (TSD circuit) is designed only to shut the IC off to prevent runaway thermal operation. It is not designed to protect the IC or guarantee its operation of the thermal shutdown circuit is assumed.
7. When modifying the external circuit components, make sure to leave an adequate margin for external components actual value and tolerance as well as dispersion of the IC.
8. About the external FET, the parasitic Capacitor may cause the gate voltage to change, when the drain voltage is switching. Make sure to leave adequate margin for this IC variation.
9. Under operating CP charge (under error mode) analog dimming and burst dimming are not operate.
10. Under operating Slow Start Control (SS is less than 1.5V), It does not operate Timer Latch.
11. By STB voltage, BD9898F, BD9898FV are changed to 2 states. Therefore, do not input STB pin voltage between one state and the other state (0.8~2.0V).
12. The pin connected a connector need to connect to the resistor for electrical surge destruction.
13. This IC is a monolithic IC which (as shown is Fig-1) has P<sup>+</sup> substrate and between the various pins. A P-N junction is formed from this P layer of each pin. For example, the relation between each potential is as follows,

- (When  $GND > PinB$  and  $GND > PinA$ , the P-N junction operates as a parasitic diode.)
- (When  $PinB > GND > PinA$ , the P-N junction operates as a parasitic transistor.)

Parasitic diodes can occur inevitably in the structure of the IC. The operation of parasitic diodes can result in mutual interference among circuits as well as operation faults and physical damage. Accordingly you must not use methods by which parasitic diodes operate, such as applying a voltage that is lower than the GND (P substrate) voltage to an input pin.

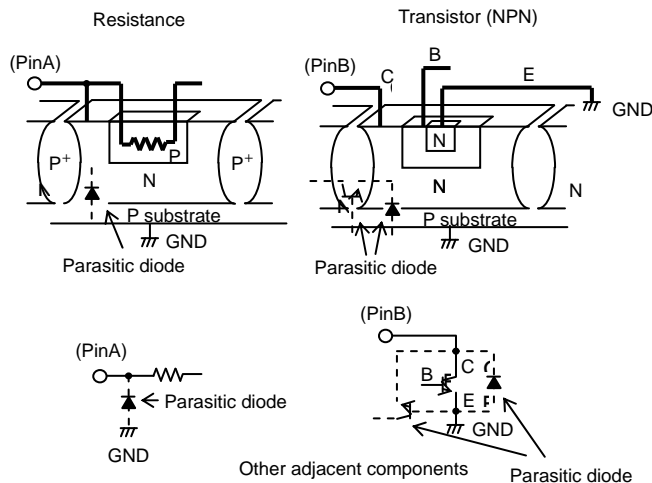

Fig-1 Simplified structure of a Bipolar IC

## Notes

No copying or reproduction of this document, in part or in whole, is permitted without the consent of ROHM Co.,Ltd.

The content specified herein is subject to change for improvement without notice.

The content specified herein is for the purpose of introducing ROHM's products (hereinafter "Products"). If you wish to use any such Product, please be sure to refer to the specifications, which can be obtained from ROHM upon request.

Examples of application circuits, circuit constants and any other information contained herein illustrate the standard usage and operations of the Products. The peripheral conditions must be taken into account when designing circuits for mass production.

Great care was taken in ensuring the accuracy of the information specified in this document. However, should you incur any damage arising from any inaccuracy or misprint of such information, ROHM shall bear no responsibility for such damage.

The technical information specified herein is intended only to show the typical functions of and examples of application circuits for the Products. ROHM does not grant you, explicitly or implicitly, any license to use or exercise intellectual property or other rights held by ROHM and other parties. ROHM shall bear no responsibility whatsoever for any dispute arising from the use of such technical information.

The Products specified in this document are intended to be used with general-use electronic equipment or devices (such as audio visual equipment, office-automation equipment, communication devices, electronic appliances and amusement devices).

The Products specified in this document are not designed to be radiation tolerant.

While ROHM always makes efforts to enhance the quality and reliability of its Products, a Product may fail or malfunction for a variety of reasons.

Please be sure to implement in your equipment using the Products safety measures to guard against the possibility of physical injury, fire or any other damage caused in the event of the failure of any Product, such as derating, redundancy, fire control and fail-safe designs. ROHM shall bear no responsibility whatsoever for your use of any Product outside of the prescribed scope or not in accordance with the instruction manual.

The Products are not designed or manufactured to be used with any equipment, device or system which requires an extremely high level of reliability the failure or malfunction of which may result in a direct threat to human life or create a risk of human injury (such as a medical instrument, transportation equipment, aerospace machinery, nuclear-reactor controller, fuel-controller or other safety device). ROHM shall bear no responsibility in any way for use of any of the Products for the above special purposes. If a Product is intended to be used for any such special purpose, please contact a ROHM sales representative before purchasing.

If you intend to export or ship overseas any Product or technology specified herein that may be controlled under the Foreign Exchange and the Foreign Trade Law, you will be required to obtain a license or permit under the Law.





Thank you for your accessing to ROHM product informations.  
More detail product informations and catalogs are available, please contact us.

## ROHM Customer Support System

<http://www.rohm.com/contact/>

## Looking for pricing, stock, or lifecycle information?

Click below to explore more details on WIN SOURCE:

-  [View BD9898FV on WIN SOURCE](#)
-  [Rohm Semiconductor](#) Information

## Optimize Your Supply Chain with WIN SOURCE Solutions

-  Global Sourcing Solution
-  Obsolete Management
-  Cost Control Management
-  Shortage Management
-  Alternative Solution
-  Excess Inventory Management