

STRUCTURE Silicon Monolithic Integrated Circuit  
 NAME OF PRODUCT DC-AC Inverter Control IC

TYPE **BD9892K**

- FUNCTION
- 4ch control with Push-Pull
  - Short circuit protection with Timer Latch
  - Sequencing easily achieved with Soft Start Control
  - Under Voltage Lock Out
  - Short circuit protection with over voltage
  - Mode-selectable the operating or stand-by mode by stand-by pin
  - Synchronous operating the other BD9892FV IC' s
  - BURST mode controlled by PWN and DC input
  - Output linear control by external DC voltage

○Absolute Maximum Ratings (Ta = 25°C)

Parameter	Symbol	Limits	Unit
Supply Voltage	Vcc	15	V
Operating Temperature Range	Topr	-40~+90	°C
Storage Temperature Range	Tstg	-55~+125	°C
Power Dissipation	Pd	1062*	mW
Maximum Junction Temperature	Tjmax	+150	°C

\*Pd derated at 8.5mW/°C for temperature above Ta = 25°C (When mounted on a PCB 70.0mm×70.0mm×1.6mm)

○Operating condition

Parameter	Symbol	Limits	Unit
Supply voltage	Vcc	5.5~14.0	V
CT oscillation frequency	fCT	20~150	kHz
BCT oscillation frequency	fBCT	0.05~0.50	kHz

Status of this document

The Japanese version of this document is the official specification.

Please use the translation version of this document as a reference to expedite understanding of the official version.

If there are any uncertainty in translation version of this document, official version takes priority.

○Electric Characteristics (Ta=25°C, VCC=7V)

Parameter	Symbol	Limits			Unit	Conditions
		MIN.	TYP.	MAX.		
((WHOLE DEVICE))						
Operating current	Icc1	—	15.0	23.0	mA	CT=0.5V
Stand-by current	Icc2	—	2	10	μA	
((OVER VOLTAGE DETECT))						
FB over voltage detect voltage	Vovf	2.20	2.40	2.60	V	
((STAND BY CONTROL))						
Stand-by voltage H	VstH	2.0	—	VCC	V	System ON
Stand-by voltage L	VstL	-0.3	—	0.8	V	System OFF
((TIMER LATCH))						
Timer Latch voltage	Vcp	1.9	2.0	2.1	V	
Timer Latch current	Icp	0.5	1.0	1.5	μA	
((BURST MODE))						
BOSC Max voltage	VburH	1.94	2.0	2.06	V	f <sub>BCT</sub> =0.2kHz BCT (A, B) common spec
BOSC Min Voltage	VburL	0.4	0.5	0.6	V	f <sub>BCT</sub> =0.2kHz BCT (A, B) common spec
BOSC constant current	IBCT	1.35/BRT	1.5/BRT	1.65/BRT	A	BCT (A, B) common spec
BOSC constant current	fBCT	292.5	300.0	307.5	Hz	BRT=36kΩ BCT=0.048μF BCT (A, B) common spec
((OSC BLOCK))						
OSC constant current	I <sub>CT</sub>	1.35/RT	1.5/RT	1.65/RT	A	
OSC Max voltage	V <sub>osch</sub>	1.8	2.0	2.2	V	f <sub>CT</sub> =60kHz
OSC Min voltage	V <sub>oscl</sub>	0.3	0.5	0.7	V	f <sub>CT</sub> =60kHz
MAX DUTY	MAXDUTY	44	46.5	49	%	f <sub>CT</sub> =60kHz
Soft start current	I <sub>SS</sub>	1.0	2.0	3.0	μA	
IS COMP detect Voltage	V <sub>isc</sub>	0.45	0.50	0.55	V	
SS COMP detect voltage	V <sub>SS</sub>	2.0	2.2	2.4	V	SS (A, B) common spec
SRT ON resistance	RSRT	—	200	400	Ω	
((UVLO BLOCK))						
Operating voltage	V <sub>A_uvloH</sub>	4.95	5.15	5.35	V	VCC (A, B) common spec
Hysteresis width	ΔV <sub>A_uvlo</sub>	0.21	0.29	0.037	V	VCC (A, B) common spec
Operating voltage (External UVLO)	V <sub>uvlo2</sub>	2.242	2.315	2.388	V	
Hysteresis width	ΔV <sub>uvlo2</sub>	0.083	0.110	0.137	V	
FB OVP Mask Threshold voltage	V <sub>uvlo_fb</sub>	2.222	2.315	2.407	V	
((REG BLOCK))						
REG output voltage	V <sub>REG</sub>	3.038	3.100	3.162	V	
REG source current	I <sub>REG</sub>	5.0	—	—	mA	
((FEED BACK BLOCK))						
IS threshold voltage	V <sub>is</sub>	1.225	1.250	1.275	V	Connected REG When V <sub>ref</sub> pin is open IS (1, 2, 3, 4) common spec
VS threshold voltage	V <sub>vs</sub>	1.220	1.250	1.280	V	VS (1, 2, 3, 4) common spec
IS source current 1	I <sub>is1</sub>	—	—	1.5	μA	DUTY=2.0V IS (1, 2, 3, 4) common spec
IS source current 2	I <sub>is2</sub>	13.0	20.0	27.0	μA	DUTY=0V, IS=0.5V IS (1, 2, 3, 4) common spec
VS source current	I <sub>vs</sub>	—	—	1.0	μA	VS (1, 2, 3, 4) common spec
((OUTPUT BLOCK))						
NAch output voltage H	V <sub>outNAH</sub>	VCC-0.3	VCC-0.1	—	V	NA (1, 2, 3, 4) common spec
NBch output voltage H	V <sub>outNBH</sub>	VCC-0.3	VCC-0.1	—	V	NB (1, 2, 3, 4) common spec
NAch output voltage L	V <sub>outNAL</sub>	—	0.1	0.3	V	NA (1, 2, 3, 4) common spec
NBch output voltage L	V <sub>outNBL</sub>	—	0.1	0.3	V	NB (1, 2, 3, 4) common spec
NAch output sink resistance	R <sub>sinkNA</sub>	—	5	10	Ω	I <sub>sink</sub> =10mA NA (1, 2, 3, 4) common spec
NAch output source resistance	R <sub>sourceNA</sub>	—	8	16	Ω	I <sub>source</sub> =10mA NA (1, 2, 3, 4) common spec
NBch output sink resistance	R <sub>sinkNB</sub>	—	5	10	Ω	I <sub>sink</sub> =10mA NB (1, 2, 3, 4) common spec
NBch output source resistance	R <sub>sourceNB</sub>	—	8	16	Ω	I <sub>source</sub> =10mA NB (1, 2, 3, 4) common spec
Drive output frequency	f <sub>out</sub>	58.5	60.0	61.5	KHz	RT=20kΩ, CT=420pF NA, NB (1, 2, 3, 4) common spec
((COMP BLOCK))						
Over voltage detect	V <sub>COMP</sub>	3.033	3.100	3.167	V	COMP (A, B) common spec
Hysteresis width	ΔV <sub>COMP</sub>	0.07	0.1	0.13	V	COMP (A, B) common spec
((PROTECT CLOCK))						
Normal output voltage	V <sub>PH</sub>	2.9	3.1	3.3	V	
Protect output voltage	V <sub>PL</sub>	—	—	0.5	V	

(This product is not designed for normal operation with in a radio active environment.)

○Package Dimensions

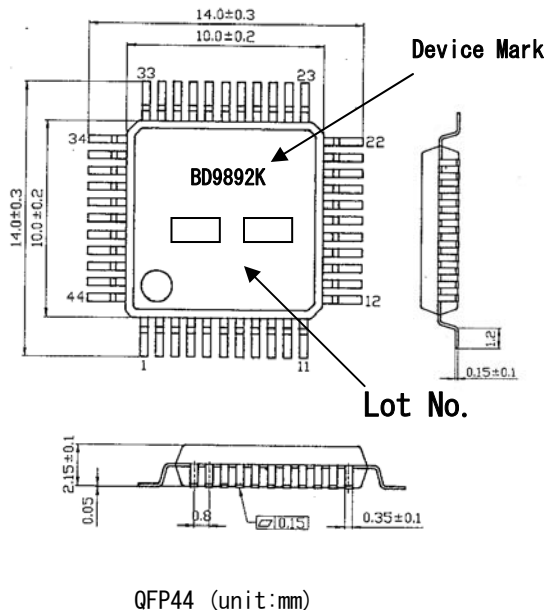

○Pin Description

Pin No.	Pin Name	Function
1	COMP_A	Over voltage detect for 1ch,2ch
2	NA1	FET driver for 1ch
3	NB1	FET driver for 1ch
4	PGND_A	Ground for FET drivers
5	NB2	FET driver for 2ch
6	NA2	FET driver for 2ch
7	STB	Stand-by switch
8	VCC_A	Supply voltage input
9	VREF	Reference voltage input for IS error amplifier
10	FAIL	Protect clock output
11	PH	Shift control input
12	REG	Internal regulator output
13	DUTY	Control PWM mode and BURST mode
14	BRT	External resistor from BRT to GND for adjusting the BURST triangle oscillator
15	BCT_B	External capacitor from BCT to GND for adjusting the BURST triangle oscillator for 3ch,4ch
16	BCT_A	External capacitor from BCT to GND for adjusting the BURST triangle oscillator for 1ch,2ch
17	GND	GROUND
18	CT	External capacitor from CT to GND for adjusting the triangle oscillator
19	RT	External resistor from RT to GND for adjusting the triangle oscillator
20	SRT	External resistor from SRT to RT for adjusting the triangle oscillator
21	CP_A	External capacitor from CP to GND for Timer Latch for 1ch,2ch
22	CP_B	External capacitor from CP to GND for Timer Latch for 3ch,4ch
23	SS_A	External capacitor from SS to GND for Soft Start Control 1ch,2ch
24	SS_B	External capacitor from SS to GND for Soft Start Control 3ch,4ch
25	VCC_B	Supply voltage input
26	UVLO	External Under Voltage Lock OUT
27	NA4	FET driver for 4ch
28	NB4	FET driver for 4ch
29	PGND_B	Ground for FET drivers
30	NB3	FET driver for 3ch
31	NA3	FET driver for 3ch
32	COMP_B	Over voltage detect for 3ch,4ch
33	VS4	Error amplifier input④
34	IS4	Error amplifier input④
35	FB4	Error amplifier output④
36	VS3	Error amplifier input③
37	IS3	Error amplifier input③
38	FB3	Error amplifier output③
39	FB2	Error amplifier output②
40	IS2	Error amplifier input②
41	VS2	Error amplifier input②
42	FB1	Error amplifier output①
43	IS1	Error amplifier input①
44	VS1	Error amplifier input①

○Block Diagram

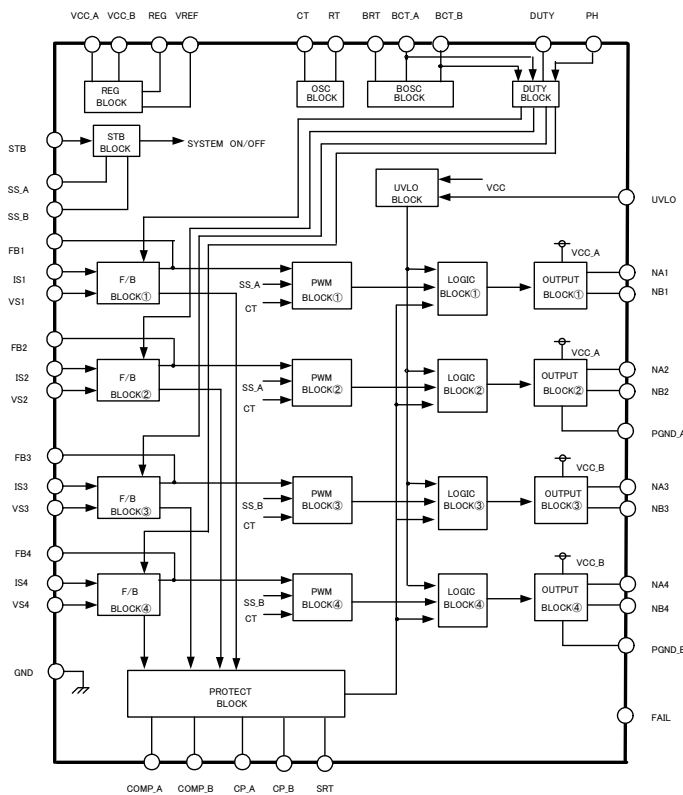

NOTE FOR USE

1. When designing the external circuit, including adequate margins for variation between external devices and the IC. Use adequate margins for steady state and transient characteristics.
2. Recommended Operating Range  
The circuit functionality is guaranteed within of ambient temperature operation range as long as it is within recommended operating range. The standard electrical characteristic values cannot be guaranteed at other voltages in the operating ranges, however, the variation will be small.
3. Mounting Failures  
Mounting failures, such as misdirection or miscounts, may harm the device.
4. Electromagnetic Fields  
A strong electromagnetic field may cause the IC to malfunction.
5. The GND pin should be the location within  $\pm 0.3V$  compared with the PGND(A,B) pin
6. BD9892K has the short circuit protection with Thermal Shut Down System. When STB or Vcc pin re-supplied, They enables to cancel the latch. If It rise the temperature of the chip more than 170°C(TYP), It make the external FET OFF
7. Absolute maximum ratings are those values that, if exceeded, may cause the life of a device to become significantly shortened. Moreover, the exact failure mode caused by short or open is not defined. Physical countermeasures, such as a fuse, need to be considered when using a device beyond its maximum ratings.
8. About the external FET, the parasitic Capacitor may cause the gate voltage to change, when the drain voltage is switching. Make sure to leave adequate margin for this IC variation.
9. On operating Slow Start Control (SS(A,B) is less than 2.2V), It does not operate Timer Latch.
10. By STB voltage, BD9892K is changed to 2 states. Therefore, do not input STB pin voltage between one state and the other state (0.8~2.0).

11. The pin connected a connector need to connect to the resistor for electrical surge destruction.
12. This IC is a monolithic IC which (as shown is Fig-1)has P<sup>+</sup> substrate and between the various pins. A P-N junction is formed from this P layer of each pin. For example, the relation between each potential is as follows,

- (When GND > PinB and GND > PinA, the P-N junction operates as a parasitic diode.)
- (When PinB > GND > PinA, the P-N junction operates as a parasitic transistor.)

Parasitic diodes can occur inevitably in the structure of the IC. The operation of parasitic diodes can result in mutual interference among circuits as well as operation faults and physical damage. Accordingly you must not use methods by which parasitic diodes operate, such as applying a voltage that is lower than the GND(P substrate)voltage to an input pin.

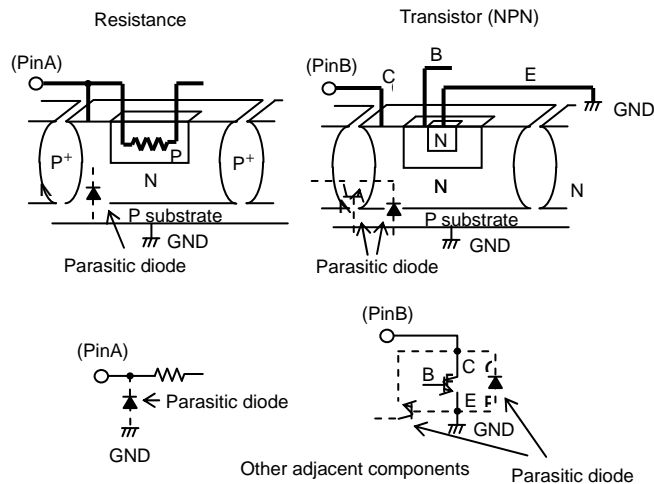

Fig. 1 Simplified structure of a Bipolar IC

## Notes

No copying or reproduction of this document, in part or in whole, is permitted without the consent of ROHM Co.,Ltd.

The content specified herein is subject to change for improvement without notice.

The content specified herein is for the purpose of introducing ROHM's products (hereinafter "Products"). If you wish to use any such Product, please be sure to refer to the specifications, which can be obtained from ROHM upon request.

Examples of application circuits, circuit constants and any other information contained herein illustrate the standard usage and operations of the Products. The peripheral conditions must be taken into account when designing circuits for mass production.

Great care was taken in ensuring the accuracy of the information specified in this document. However, should you incur any damage arising from any inaccuracy or misprint of such information, ROHM shall bear no responsibility for such damage.

The technical information specified herein is intended only to show the typical functions of and examples of application circuits for the Products. ROHM does not grant you, explicitly or implicitly, any license to use or exercise intellectual property or other rights held by ROHM and other parties. ROHM shall bear no responsibility whatsoever for any dispute arising from the use of such technical information.

The Products specified in this document are intended to be used with general-use electronic equipment or devices (such as audio visual equipment, office-automation equipment, communication devices, electronic appliances and amusement devices).

The Products specified in this document are not designed to be radiation tolerant.

While ROHM always makes efforts to enhance the quality and reliability of its Products, a Product may fail or malfunction for a variety of reasons.

Please be sure to implement in your equipment using the Products safety measures to guard against the possibility of physical injury, fire or any other damage caused in the event of the failure of any Product, such as derating, redundancy, fire control and fail-safe designs. ROHM shall bear no responsibility whatsoever for your use of any Product outside of the prescribed scope or not in accordance with the instruction manual.

The Products are not designed or manufactured to be used with any equipment, device or system which requires an extremely high level of reliability the failure or malfunction of which may result in a direct threat to human life or create a risk of human injury (such as a medical instrument, transportation equipment, aerospace machinery, nuclear-reactor controller, fuel-controller or other safety device). ROHM shall bear no responsibility in any way for use of any of the Products for the above special purposes. If a Product is intended to be used for any such special purpose, please contact a ROHM sales representative before purchasing.

If you intend to export or ship overseas any Product or technology specified herein that may be controlled under the Foreign Exchange and the Foreign Trade Law, you will be required to obtain a license or permit under the Law.





Thank you for your accessing to ROHM product informations.  
More detail product informations and catalogs are available, please contact us.

### ROHM Customer Support System

<http://www.rohm.com/contact/>

## Looking for pricing, stock, or lifecycle information?

Click below to explore more details on WIN SOURCE:

-  [View BD9892K-E2 on WIN SOURCE](#)
-  [Rohm Semiconductor](#) Information

## Optimize Your Supply Chain with WIN SOURCE Solutions

-  Global Sourcing Solution
-  Obsolete Management
-  Cost Control Management
-  Shortage Management
-  Alternative Solution
-  Excess Inventory Management