



**THE DATASHEET OF
MKS22FN128VLL12**



KS22/KS20 Microcontroller

120 MHz ARM® Cortex®-M4, with up to 256 KB Flash

The KS2x product family is built on the ARM® Cortex®-M4 processor with lower power and higher memory densities in multiple packages. This device offers 120 MHz performance with an integrated single-precision floating point unit (FPU).

Embedded flash memory sizes range from 128 KB to 256KB.

This device also includes:

- USB FS OTG 2.0 with crystal-less functionality
- FlexCAN, supporting CAN protocol according to the ISO 11898-1 standard and CAN 2.0 B protocol specifications
- FlexIO, a highly configurable module providing a wide range of protocols including, but not limited to UART, LPI2C, SPI, I2S, and PWM/Waveform generation.

MKS22FN256Vxx12
MKS22FN128Vxx12
MKS20FN256Vxx12
MKS20FN128Vxx12

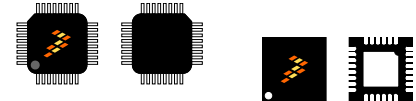

100 & 64 LQFP (LL & LH)
14x14x1.7 mm Pitch 0.5 mm; 10x10x1.6 mm Pitch 0.5 mm

48 QFN (FT)
7x7x0.65 mm Pitch 0.5 mm

Performance

- 120 MHz ARM Cortex-M4 core with DSP instructions delivering 1.25 Dhrystone MIPS per MHz

Memories and memory interfaces

- Up to 256 KB of embedded flash and 64 KB of SRAM
- Preprogrammed Kinetis Flashloader for one-time, in-system factory programming

System peripherals

- Flexible low-power modes, multiple wake up sources
- 16-channel asynchronous DMA controller
- Independent external and software watchdog monitor

Clocks

- Two crystal oscillators: 32 kHz (RTC), and 32-40 kHz or 3-32 MHz
- Three internal oscillators: 32 kHz, 4 MHz, and 48 MHz
- Multi-purpose clock generator (MCG) with PLL and FLL

Security and integrity modules

- Hardware CRC module
- 128-bit unique identification (UID) number per chip
- Hardware random-number generator
- Flash access control (FAC) to protect proprietary software

Human-machine interfaces

- Up to 66 general-purpose input/output pins (GPIO)

Analog modules

- One 16-bit ADC module with up to 17 single-end channels and 4 differential channels, and up to 1.2 Msps at \leq 13-bit mode
- One 12-bit DAC module
- One analog comparator (CMP) module

Communication interfaces

- USB FS/LS OTG 2.0 with on-chip transceiver
- One FlexIO module
- Three UART modules (one supporting ISO7816, and the other two operating up to 1.5 Mbit/s)
- One LPUART module supporting asynchronous operation in low-power modes
- Two LPI2C modules supporting up to 5 Mbit/s, asynchronous operation in low-power modes supported
- Two 16-bit SPI modules supporting up to 30 Mbit/s
- Two FlexCAN modules for KS22, One FlexCAN for KS20
- Two I2S modules

Timers

- Three 16-bit low-power timer PWM modules (TPM)
- One low-power timer (LPTMR)
- Periodic interrupt timer (PIT)

Operating characteristics

- Voltage range (including flash writes): 1.71 to 3.6 V
- Temperature range (ambient): -40 to 105 °C
- Real time clock (RTC), with independent power domain
- Programmable delay block (PDB)

Related Resources

Type	Description	Resource
Product Brief	The Product Brief contains concise overview/summary information to enable quick evaluation of a device for design suitability.	KS22PB ¹
Reference Manual	The Reference Manual contains a comprehensive description of the structure and function (operation) of a device.	KS22P100M120SF0RM ¹
Data Sheet	The Data Sheet includes electrical characteristics and signal connections.	This document: KS22P100M120SF0 ¹
Chip Errata	The chip mask set Errata provides additional or corrective information for a particular device mask set.	KINETIS_K_0N87R ¹
Package drawing	Package dimensions are provided in package drawings.	LQFP 100-pin: 98ASS23308W LQFP 64-pin: 98ASS23234W QFN 48-pin: 98ASA00616D

1. To find the associated resource, go to <http://www.nxp.com> and perform a search using this term.

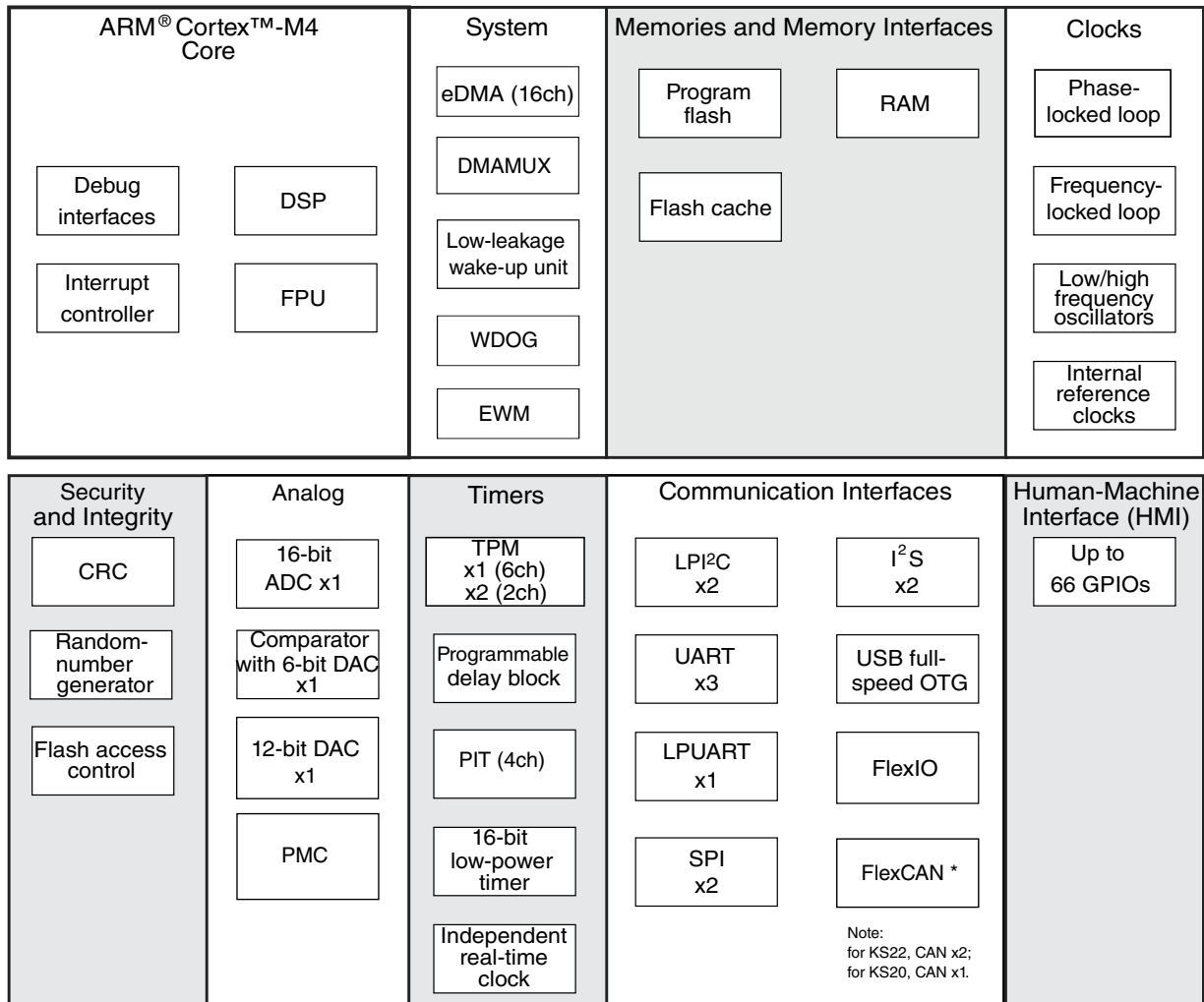

Figure 1. Functional block diagram

NOTE

DAC0 and I²S1 are NOT supported in the 48-QFN package. For more details, see the "Signal Multiplexing and Pin Assignments" section.

Table of Contents

1	Ordering information.....	5	4.3.7	Human-Machine Interfaces (HMI).....	47
2	Overview.....	6	4.4	Pinouts.....	47
2.1	System features.....	7	4.5	Package dimensions.....	50
2.1.1	ARM Cortex-M4 core.....	7	5	Electrical characteristics.....	56
2.1.2	NVIC.....	7	5.1	Terminology and guidelines.....	56
2.1.3	AWIC.....	7	5.1.1	Definitions.....	56
2.1.4	Memory.....	8	5.1.2	Examples.....	57
2.1.5	Reset and boot.....	9	5.1.3	Typical-value conditions.....	58
2.1.6	Clock options.....	10	5.1.4	Relationship between ratings and operating requirements.....	58
2.1.7	Security.....	13	5.1.5	Guidelines for ratings and operating requirements.....	59
2.1.8	Power management.....	14	5.2	Ratings.....	59
2.1.9	LLWU.....	16	5.2.1	Thermal handling ratings.....	59
2.1.10	Debug controller.....	17	5.2.2	Moisture handling ratings.....	60
2.1.11	Computer operating properly (COP) watchdog timer.....	17	5.2.3	ESD handling ratings.....	60
2.2	Peripheral features.....	17	5.2.4	Voltage and current operating ratings.....	60
2.2.1	eDMA and DMAMUX.....	18	5.3	General.....	60
2.2.2	TPM.....	18	5.3.1	AC electrical characteristics.....	61
2.2.3	ADC.....	19	5.3.2	Nonswitching electrical specifications.....	61
2.2.4	DAC.....	19	5.3.3	Switching specifications.....	72
2.2.5	CMP.....	20	5.3.4	Thermal specification.....	74
2.2.6	RTC.....	21	5.4	Peripheral operating requirements and behaviors.....	75
2.2.7	PIT.....	21	5.4.1	Debug modules.....	75
2.2.8	PDB.....	21	5.4.2	System modules.....	80
2.2.9	LPTMR.....	22	5.4.3	Clock modules.....	80
2.2.10	CRC.....	22	5.4.4	Memories and memory interfaces.....	86
2.2.11	UART.....	23	5.4.5	Security and integrity modules.....	87
2.2.12	LPUART.....	23	5.4.6	Analog.....	87
2.2.13	SPI.....	24	5.4.7	Timers.....	97
2.2.14	FlexCAN.....	24	5.4.8	Communication interfaces.....	97
2.2.15	LPI2C.....	26	6	Design considerations.....	108
2.2.16	USB.....	26	6.1	Hardware design considerations.....	108
2.2.17	I2S.....	27	6.1.1	Printed circuit board recommendations.....	108
2.2.18	FlexIO.....	27	6.1.2	Power delivery system.....	108
2.2.19	Port control and GPIO.....	28	6.1.3	Analog design.....	109
3	Memory map.....	30	6.1.4	Digital design.....	110
4	Pinouts.....	31	6.1.5	Crystal oscillator.....	113
4.1	Signal Multiplexing and Pin Assignments.....	31	6.2	Software considerations.....	114
4.2	Pin properties.....	34	7	Part identification.....	115
4.3	Module Signal Description Tables.....	39	7.1	Description.....	115
4.3.1	Core Modules.....	39	7.2	Format.....	115
4.3.2	System Modules.....	40	7.3	Fields.....	115
4.3.3	Clock Modules.....	40	7.4	Example.....	116
4.3.4	Analog.....	41	8	Revision history.....	116
4.3.5	Timer Modules.....	41			
4.3.6	Communication Interfaces.....	43			

1 Ordering information

The following chips are available for ordering.

Table 1. Ordering information

Product		Memory		Package		IO and ADC channel			Commu- nication
Part number	Marking (Line1/Line2)	Flash (KB)	SRAM (KB)	Pin count	Package	GPIOs	GPIOs (INT/HD) ¹	ADC channel s (SE/DP) ²	FlexCAN
MKS22F N256VLL 12	MKS22FN256 / VLL12	256	64	100	LQFP	66	66/8	17/4	2
MKS22F N256VLH 12	MKS22FN256 / VLH12	256	64	64	LQFP	40	40/8	14/2 ³	2
MKS22F N256VFT 12	MKS22FN256 / VFT12	256	64	48	QFN	35	35/8	13/—	2
MKS22F N128VLL 12	MKS22FN128 / VLL12	128	64	100	LQFP	66	66/8	17/4	2
MKS22F N128VLH 12	MKS22FN128 / VLH12	128	64	64	LQFP	40	40/8	14/2 ³	2
MKS22F N128VFT 12	MKS22FN128 / VFT12	128	64	48	QFN	35	35/8	13/—	2
MKS20F N256VLL 12	MKS20FN256 / VLL12	256	64	100	LQFP	66	66/8	17/4	1
MKS20F N256VLH 12	MKS20FN256 / VLH12	256	64	64	LQFP	40	40/8	14/2 ³	1
MKS20F N256VFT 12	MKS20FN256 / VFT12	256	64	48	QFN	35	35/8	13/—	1
MKS20F N128VLL 12	MKS20FN128 / VLL12	128	64	100	LQFP	66	66/8	17/4	1
MKS20F N128VLH 12	MKS20FN128 / VLH12	128	64	64	LQFP	40	40/8	14/2 ³	1
MKS20F N128VFT 12	MKS20FN128 / VFT12	128	64	48	QFN	35	35/8	13/—	1

Overview

1. INT: interrupt pin numbers; HD: high drive pin numbers
2. SE: single-ended; DP: differential pair
3. ADC0_DP1 is for single-ended (SE) mode only in 64-LQFP.

2 Overview

The following figure shows the system diagram of this device.

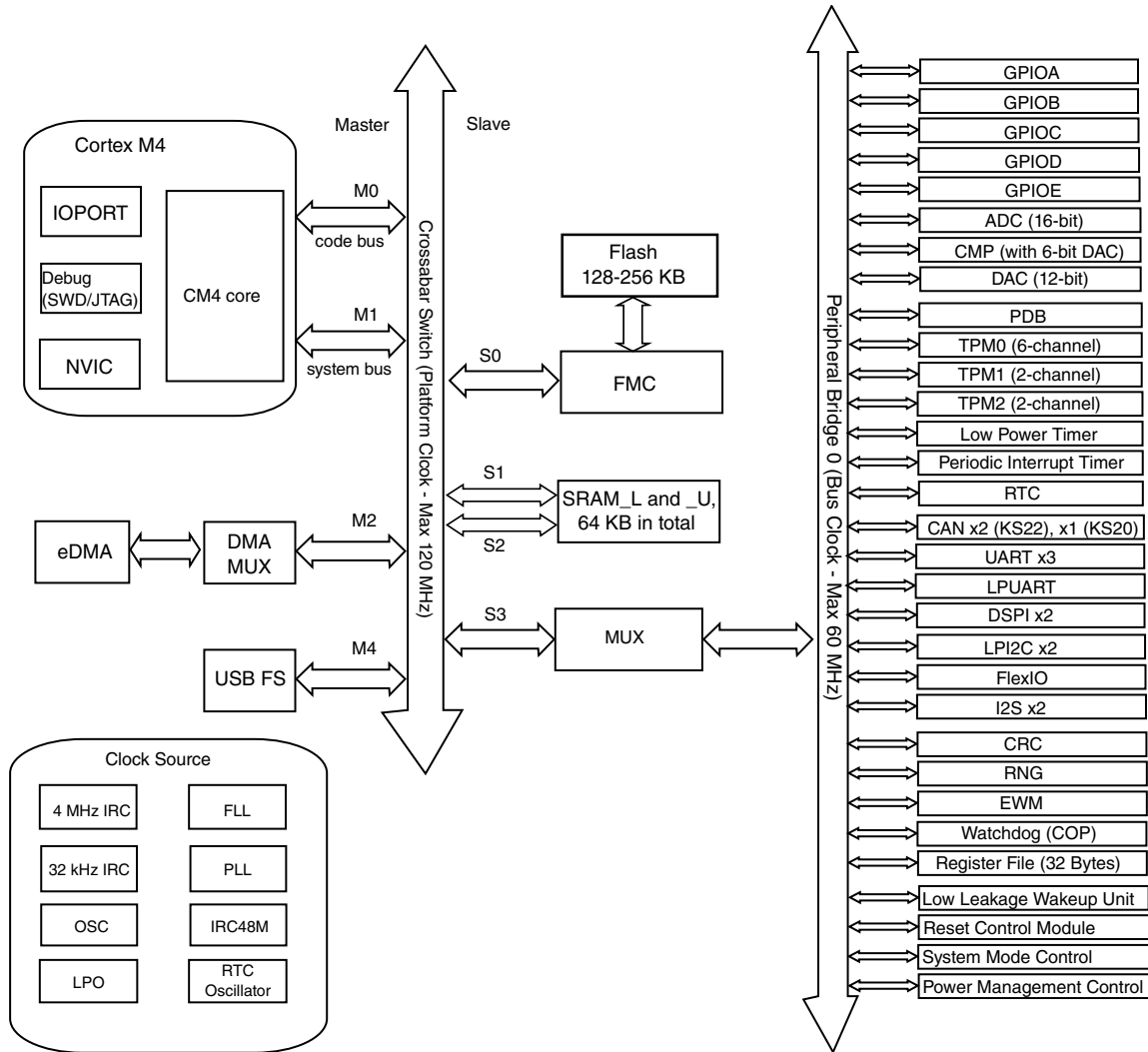

Figure 2. System diagram

The crossbar switch connects bus masters and slaves using a crossbar switch structure. This structure allows up to four bus masters to access different bus slaves simultaneously, while providing arbitration among the bus masters when they access the same slave.

2.1 System features

The following sections describe the high-level system features.

2.1.1 ARM Cortex-M4 core

The ARM Cortex-M4 is the member of the Cortex M Series of processors targeting microcontroller cores focused on very cost sensitive, deterministic, interrupt driven environments. The Cortex M4 processor is based on the ARMv7 Architecture and Thumb®-2 ISA and is upward compatible with the Cortex M3, Cortex M1, and Cortex M0 architectures. Cortex M4 improvements include an ARMv7 Thumb-2 DSP (ported from the ARMv7-A/R profile architectures) providing 32-bit instructions with SIMD (single instruction multiple data) DSP style multiply-accumulates and saturating arithmetic.

2.1.2 NVIC

The Nested Vectored Interrupt Controller supports nested interrupts and 16 priority levels for interrupts. In the NVIC, each source in the IPR registers contains 4 bits. It also differs in number of interrupt sources and supports 240 interrupt vectors.

The Cortex-M family uses a number of methods to improve interrupt latency . It also can be used to wake the MCU core from Wait and VLPW modes.

2.1.3 AWIC

The asynchronous wake-up interrupt controller (AWIC) is used to detect asynchronous wake-up events in Stop mode and signal to clock control logic to resume system clocking. After clock restarts, the NVIC observes the pending interrupt and performs the normal interrupt or event processing. The AWIC can be used to wake MCU core from Partial Stop, Stop and VLPS modes.

Wake-up sources for this SoC are listed as below:

Table 2. AWIC Partial Stop, Stop and VLPS Wake-up Sources

Wake-up source	Description
Available system resets	$\overline{\text{RESET}}$ pin and WDOG when LPO is its clock source, and JTAG
Low voltage detect	Power Mode Controller
Low voltage warning	Power Mode Controller
High voltage detect	Power Mode Controller
Pin interrupts	Port Control Module - Any enabled pin interrupt is capable of waking the system
ADC	The ADC is functional when using internal clock source
CMP	Since no system clocks are available, functionality is limited, trigger mode provides wakeup functionality with periodic sampling
LPI ² C	Functional when using clock source which is active in Stop and VLPS modes
FlexIO	Functional when using clock source which is active in Stop and VLPS modes
TPM	Functional when using clock source which is active in Stop and VLPS modes
UART	Active edge on RXD
LPUART	Functional when using clock source which is active in Stop and VLPS modes
USB FS/LS Controller	Wakeup
LPTMR	Functional when using clock source which is active in Stop and VLPS modes
RTC	Functional in Stop/VLPS modes
I2S (SAI)	Functional when using an external bit clock or external master clock
TPM	Functional when using clock source which is active in Stop and VLPS modes
CAN	Wakeup on edge (CANx_RX)
NMI	Non-maskable interrupt

2.1.4 Memory

This device has the following features:

- 64 KB of embedded RAM accessible (read/write) at CPU clock speed with 0 wait states.
- The non-volatile memory is divided into
 - 128/256 KB of embedded program memory

The program flash memory contains a 16-byte flash configuration field that stores default protection settings and security information. The page size of program flash is 2 KB.

The protection setting can protect 32 regions of the program flash memory from unintended erase or program operations.

The security circuitry prevents unauthorized access to RAM or flash contents from debug port.

- System register file

This device contains a 32-byte register file that is powered in all power modes.

Also, it retains contents during low power modes and is reset only during a power-on reset.

2.1.5 Reset and boot

The following table lists all the reset sources supported by this device.

NOTE

In the following table, Y means the specific module, except for the registers, bits or conditions mentioned in the footnote, is reset by the corresponding Reset source. N means the specific module is not reset by the corresponding Reset source.

Table 3. Reset source

Reset sources	Descriptions	Modules								
		PMC	SIM	SMC	RCM	LLWU	Reset pin is negated	RTC	LPTM R	Others
POR reset	Power-on reset (POR)	Y	Y	Y	Y	Y	Y	Y	Y	Y
System resets	Low-voltage detect (LVD)	Y ¹	Y	Y	Y	Y	Y	N	Y	Y
	Low leakage wakeup (LLWU) reset	N	Y ²	N	Y	N	Y ³	N	N	Y
	External pin reset (RESET)	Y ¹	Y ²	Y ⁴	Y	Y	Y	N	N	Y
	Watchdog (WDOG) reset	Y ¹	Y ²	Y ⁴	Y ⁵	Y	Y	N	N	Y
	Multipurpose clock generator loss of clock (LOC) reset	Y ¹	Y ²	Y ⁴	Y ⁵	Y	Y	N	N	Y
	Multipurpose clock generator loss of lock (LOL) reset	Y ¹	Y ²	Y ⁴	Y ⁵	Y	Y	N	N	Y
	Stop mode acknowledge error (SACKERR)	Y ¹	Y ²	Y ⁴	Y ⁵	Y	Y	N	N	Y
	Software reset (SW)	Y ¹	Y ²	Y ⁴	Y ⁵	Y	Y	N	N	Y
Lockup reset (LOCKUP)	Y ¹	Y ²	Y ⁴	Y ⁵	Y	Y	N	N	Y	

Table continues on the next page...

Table 3. Reset source (continued)

Reset sources	Descriptions	Modules								
		PMC	SIM	SMC	RCM	LLWU	Reset pin is negated	RTC	LPTMR	Others
	MDM DAP system reset	Y ¹	Y ²	Y ⁴	Y ⁵	Y	Y	N	N	Y
Debug reset	Debug reset	Y ¹	Y ²	Y ⁴	Y ⁵	Y	Y	N	N	Y

1. Except PMC_LVDSC1[LVDV] and PMC_LVDSC2[LVWV]
2. Except SIM_SOPT1
3. Only if RESET is used to wake from VLLS mode.
4. Except SMC_PMCTRL, SMC_STOPCTRL, SMC_PMSTAT
5. Except RCM_RPFC, RCM_RPFW, RCM_FM

This device supports booting from:

- internal flash

2.1.6 Clock options

The MCG module controls which clock source is used to derive the system clocks. The clock generation logic divides the selected clock source into a variety of clock domains, including the clocks for the system bus masters, system bus slaves, and flash memory . The clock generation logic also implements module-specific clock gating to allow granular shutoff of modules.

The primary clocks for the system are generated from the MCGOUTCLK clock. The clock generation circuitry provides several clock dividers that allow different portions of the device to be clocked at different frequencies. This allows for trade-offs between performance and power dissipation.

Various modules, such as the USB OTG Controller, have module-specific clocks that can be generated from the IRC48MCLK or MCGPLLCLK or MCGFLLCLK clock. In addition, there are various other module-specific clocks that have other alternate sources. Clock selection for most modules is controlled by the SOPT registers in the SIM module.

For more details on the clock operations and configurations, see the Clock Distribution chapter in the Reference Manual.

The following figure is a high level block diagram of the clock generation.

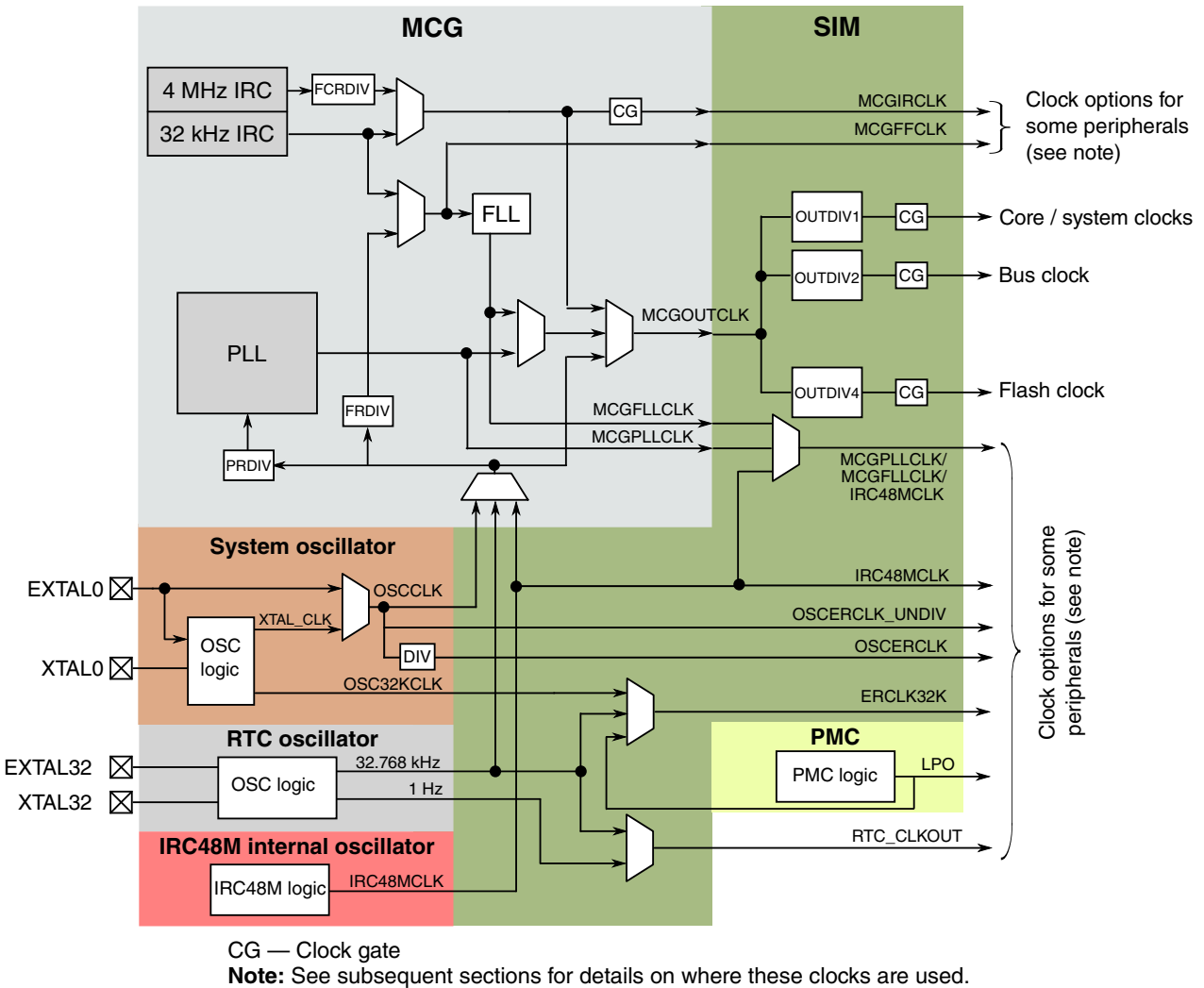

Figure 3. Clock block diagram

In order to provide flexibility, many peripherals can select the clock source to use for operation. This enables the peripheral to select a clock that will always be available during operation in various operational modes.

The following table summarizes the clocks associated with each module.

Table 4. Module clocks

Module	Bus interface clock	Internal clocks	I/O interface clocks
Core modules			
ARM Cortex-M4 core	System clock	Core clock	—
NVIC	System clock	—	—
DAP	System clock	—	—

Table continues on the next page...

Table 4. Module clocks (continued)

Module	Bus interface clock	Internal clocks	I/O interface clocks
ITM	System clock	—	—
cJTAG, JTAGC	—	—	JTAG_CLK
System modules			
DMA	System clock	—	—
DMA Mux	Bus clock	—	—
Port control	Bus clock	LPO	—
Crossbar Switch	System clock	—	—
Peripheral bridges	System clock	Bus clock, Flash clock	—
LLWU, PMC, SIM, RCM	Flash clock	LPO	—
Mode controller	Flash clock	—	—
MCM	System clock	—	—
EWM	Bus clock	LPO	—
Watchdog timer	Bus clock	LPO	—
Clocks			
MCG	Flash clock	MCGOUTCLK, MCGPLLCLK, MCGFLLCLK, MCGIRCLK, OSCCLK, RTC OSC, IRC48MCLK	—
OSC	Bus clock	OSCERCLK, OSCCLK, OSCERCLK_UNDIV, OSC32KCLK	—
IRC48M	—	IRC48MCLK	—
Memory and memory interfaces			
Flash Controller	System clock	Flash clock	—
Flash memory	Flash clock	—	—
Security			
CRC	Bus clock	—	—
RNGA	Bus clock	—	—
Analog			
ADC	Bus clock	OSCERCLK , IRC48MCLK	—
CMP	Bus clock	—	—
DAC	Bus clock	—	—
Timers			
TPM	Bus clock	TPM clock	TPM_CLKIN0, TPM_CLKIN1
PDB	Bus clock	—	—
PIT	Bus clock	—	—
LPTMR	Flash clock	LPO, OSCERCLK, MCGIRCLK, ERCLK32K	—
RTC	Flash clock	EXTAL32	—
Communication interfaces			

Table continues on the next page...

Table 4. Module clocks (continued)

Module	Bus interface clock	Internal clocks	I/O interface clocks
USB FS OTG	System clock	USB FS clock	—
DSPI	Bus clock	—	DSPI_SCK
LPI ² C	Bus clock	LPI2C clock	I2C_SCL
UART0, UART1	System clock	—	—
UART2	Bus clock	—	—
LPUART0	Bus clock	LPUART0 clock	—
I ² S	Bus clock	I ² S master clock	I2S_TX_BCLK, I2S_RX_BCLK
FlexCAN	Bus clock	FlexCAN clock	—
FlexIO	Bus clock	FlexIO clock	—
Human-machine interfaces			
GPIO	Platform clock	—	—

2.1.7 Security

Security state can be enabled via programming flash configure field (0x40e). After enabling device security, the SWD/JTAG port cannot access the memory resources of the MCU.

External interface	Security	Unsecure
SWD/JTAG port	Can't access memory source by SWD/JTAG interface	the debugger can write to the Flash Mass Erase in Progress field of the MDM-AP Control register to trigger a mass erase (Erase All Blocks) command

2.1.7.1 Flash Access Control (FAC)

The FAC is a native or third-party configurable memory protection scheme optimized to allow end users to utilize software libraries while offering programmable restrictions to these libraries. The flash memory is divided into equal size segments that provide protection to proprietary software libraries. The protection of these segments is controlled as the FAC provides a cycle-by-cycle evaluation of the access rights for each transaction routed to the on-chip flash memory. Configurability allows an increasing number of protected segments while supporting two levels of vendors adding their proprietary software to a device.

2.1.8 Power management

The Power Management Controller (PMC) expands upon ARM's operational modes of Run, Sleep, and Deep Sleep, to provide multiple configurable modes. These modes can be used to optimize current consumption for a wide range of applications. The WFI or WFE instruction invokes a Wait or a Stop mode, depending on the current configuration. For more information on ARM's operational modes, See the ARM[®] Cortex[®] User Guide.

The PMC provides High Speed Run (HSRUN), Normal Run (RUN), and Very Low Power Run (VLPR) configurations in ARM's Run operation mode. In these modes, the MCU core is active and can access all peripherals. The difference between the modes is the maximum clock frequency of the system and therefore the power consumption. The configuration that matches the power versus performance requirements of the application can be selected.

The PMC provides Wait (Wait) and Very Low Power Wait (VLPW) configurations in ARM's Sleep operation mode. In these modes, even though the MCU core is inactive, all of the peripherals can be enabled and operate as programmed. The difference between the modes is the maximum clock frequency of the system and therefore the power consumption.

The PMC provides Stop (Stop), Very Low Power Stop (VLPS), Low Leakage Stop (LLS), and Very Low Leakage Stop (VLLS) configurations in ARM's Deep Sleep operational mode. In these modes, the MCU core and most of the peripherals are disabled. Depending on the requirements of the application, different portions of the analog, logic, and memory can be retained or disabled to conserve power.

The Battery Backup mode allows the VBAT voltage domain to operate while the rest of the device is disabled to conserve power. All modules in the VBAT domain are functional in this mode of operation.

The Nested Vectored Interrupt Controller (NVIC), the Asynchronous Wake-up Interrupt Controller (AWIC), and the Low Leakage Wake-Up Controller (LLWU) are used to wake up the MCU from low power states. The NVIC is used to wake up the MCU core from WAIT and VLPW modes. The AWIC is used to wake up the MCU core from STOP and VLPS modes. The LLWU is used to wake up the MCU core from LLS and VLLSx modes.

For additional information regarding operational modes, power management, the NVIC, AWIC, or the LLWU, please refer to the Reference Manual.

The following table provides information about the state of the peripherals in the various operational modes and the modules that can wake MCU from low power modes.

Table 6. Peripherals states in different operational modes

Core mode	Device mode	Descriptions
Run mode	High Speed Run	In HSRun mode, MCU is able to operate at a faster frequency, and all device modules are operational.
	Run	In Run mode, all device modules are operational.
	Very Low Power Run	In VLPR mode, all device modules are operational at a reduced frequency except the Low Voltage Detect (LVD) monitor, which is disabled.
Sleep mode	Wait	In Wait mode, all peripheral modules are operational. The MCU core is placed into Sleep mode.
	Very Low Power Wait	In VLPW mode, all peripheral modules are operational at a reduced frequency except the Low Voltage Detect (LVD) monitor, which is disabled. The MCU core is placed into Sleep mode.
Deep sleep	Stop	In Stop mode, most peripheral clocks are disabled and placed in a static state. Stop mode retains all registers and SRAMs while maintaining Low Voltage Detection protection. In Stop mode, the ADC, DAC, CMP, LPTMR, RTC, and pin interrupts are operational. The NVIC is disabled, but the AWIC can be used to wake up from an interrupt.
	Very Low Power Stop	In VLPS mode, the contents of the SRAM are retained. The CMP (low speed), ADC, OSC, RTC, LPTMR, TPM, FlexIO, LPUART, LPI2C, USB, and DMA are operational, LVD and NVIC are disabled, AWIC is used to wake up from interrupt.
	Low Leakage Stop (LLS3/LLS2)	State retention power mode. Most peripherals are in state retention mode (with clocks stopped), but LLWU, LPTMR, RTC, CMP, DAC can be used. NVIC is disabled; LLWU is used to wake up. NOTE: The LLWU interrupt must not be masked by the interrupt controller to avoid a scenario where the system does not fully exit stop mode on an LLS recovery. In LLS3 mode, all SRAM is operating (content retained and I/O states held). In LLS2 mode, a portion of SRAM_U remains powered on (content retained and I/O states held).
	Very Low Leakage Stop (VLLSx)	Most peripherals are disabled (with clocks stopped), but LLWU, LPTMR, RTC, CMP, DAC can be used. NVIC is disabled; LLWU is used to wake up. In VLLS3, SRAM_U and SRAM_L remain powered on (content retained and I/O states held). In VLLS2, SRAM_L is powered off. A portion of SRAM_U remains powered on (content retained and I/O states held). In VLLS1 and VLLS0, all of SRAM_U and SRAM_L are powered off. The 32-byte system register file and 32-byte VBAT register file remain powered for customer-critical data. In VLLS0, The POR detect circuit can be optionally powered off.
Powered Off	Battery Backup	The RTC and 32-byte VBAT register file are powered from the VBAT domain and is fully functional. The rest of the device is powered down.

2.1.9 LLWU

The LLWU module is used to wake MCU from low leakage power mode (LLS and VLLSx) and functional only on entry into a low-leakage power mode. After recovery from LLS, the LLWU is immediately disabled. After recovery from VLLSx, the LLWU continues to detect wake-up events until the user has acknowledged the wake-up event.

The following is internal peripheral and external pin inputs as wakeup sources to the LLWU module.

Table 7. Wakeup sources for LLWU inputs

Input	Wakeup source
LLWU_P0	PTE1/LLWU_P0 pin
LLWU_P1	PTE2/LLWU_P1 pin
LLWU_P2	PTE4/LLWU_P2 pin
LLWU_P3	PTA4/LLWU_P3 pin ¹
LLWU_P4	PTA13/LLWU_P4 pin
LLWU_P5	PTB0/LLWU_P5 pin
LLWU_P6	PTC1/LLWU_P6 pin
LLWU_P7	PTC3/LLWU_P7 pin
LLWU_P8	PTC4/LLWU_P8 pin
LLWU_P9	PTC5/LLWU_P9 pin
LLWU_P10	PTC6/LLWU_P10 pin
LLWU_P11	PTC11/LLWU_P11 pin
LLWU_P12	PTD0/LLWU_P12 pin
LLWU_P13	PTD2/LLWU_P13 pin
LLWU_P14	PTD4/LLWU_P14 pin
LLWU_P15	PTD6/LLWU_P15 pin
LLWU_P16	Reserved
LLWU_P17	Reserved
LLWU_P18	Reserved
LLWU_P19	Reserved
LLWU_P20	Reserved
LLWU_P21	Reserved
LLWU_P22	Reserved
LLWU_P23	Reserved
LLWU_P24	Reserved
LLWU_P25	Reserved
LLWU_P26	USBVDD

Table continues on the next page...

Table 7. Wakeup sources for LLWU inputs (continued)

Input	Wakeup source
LLWU_P27	USB0_DP
LLWU_P28	USB0_DM ²
LLWU_P29	Reserved
LLWU_P30	Reserved
LLWU_P31	Reserved
LLWU_M0IF	LPTMR ³
LLWU_M1IF	CMP0
LLWU_M2IF	Reserved
LLWU_M3IF	Reserved
LLWU_M4IF	Reserved
LLWU_M5IF	RTC Alarm ³
LLWU_M6IF	Reserved
LLWU_M7IF	RTC Seconds ³

1. If NMI was enabled on entry to LLS/VLLS, asserting the NMI pin generates an NMI interrupt on exit from the low power mode. NMI can also be disabled via the FOPT[NMI_DIS] bit.
2. As a wakeup source of LLWU, USB0_DP and USB0_DM are only available when the chip is in USB host mode.
3. It requires the peripheral and the peripheral interrupt to be enabled. The LLWU's WUME bit enables the internal module flag as a wakeup input. After wakeup, the flags are cleared based on the peripheral clearing mechanism.

2.1.10 Debug controller

This device has extensive debug capabilities including run control and tracing capabilities. The standard ARM debug port supports SWD/JTAG interface. Also the cJTAG interface is supported on this device.

2.1.11 Computer operating properly (COP) watchdog timer

The computer operating properly (COP) watchdog timer (WDOG) monitors the operation of the system by expecting periodic communication from the software. This communication is generally known as servicing (or refreshing) the COP watchdog. If this periodic refreshing does not occur, the watchdog issues a system reset.

2.2 Peripheral features

The following sections describe the features of each peripherals of the chip.

2.2.1 eDMA and DMAMUX

The eDMA is a highly programmable data-transfer engine optimized to minimize any required intervention from the host processor. It is intended for use in applications where the data size to be transferred is statically known and not defined within the transferred data itself. The DMA controller in this device implements 16 channels which can be routed from up to 63 DMA request sources through DMA MUX module.

Main features of eDMA are listed below:

- All data movement via dual-address transfers: read from source, write to destination
- 16-channel implementation that performs complex data transfers with minimal intervention from a host processor
- Transfer control descriptor (TCD) organized to support two-deep, nested transfer operations
- Channel activation via one of three methods
- Fixed-priority and round-robin channel arbitration
- Channel completion reported via programmable interrupt requests
- Programmable support for scatter/gather DMA processing
- Support for complex data structures

2.2.2 TPM

This device contains three low power Timer/PWM Modules (TPM), one with 6 channels and the other two with 2 channels. All TPM modules are functional in Stop/VLPS mode if the clock source is enabled.

The TPM features are as follows:

- TPM clock mode is selectable (can increment on every edge of the asynchronous counter clock, or only on on rising edge of an external clock input synchronized to the asynchronous counter clock)
- Prescaler divide-by 1, 2, 4, 8, 16, 32, 64, or 128
- Include a 16-bit counter
- Include 6 or 2 channels (1×6ch, 2×2ch) that can be configured for input capture, output compare, edge-aligned PWM mode, or center-aligned PWM mode
- Support the generation of an interrupt and/or DMA request per channel or counter overflow

- Support selectable trigger input to optionally reset or cause the counter to start or stop incrementing
- Support the generation of hardware triggers when the counter overflows and per channel

2.2.3 ADC

This device contains one ADC module. This ADC module supports hardware triggers from TPM, LPTMR, PIT, RTC, external trigger pin and CMP output. It supports wakeup of MCU in low power mode when using internal clock source or external crystal clock.

ADC module has the following features:

- Linear successive approximation algorithm with up to 16-bit resolution
- Up to four pairs of differential and 17 single-ended external analog inputs
- Support selectable 16-bit, 13-bit, 11-bit, and 9-bit differential output mode, or 16-bit, 12-bit, 10-bit, and 8-bit single-ended output modes
- Single or continuous conversion
- Configurable sample time and conversion speed/power
- Selectable clock source up to three
- Operation in low-power modes for lower noise
- Asynchronous clock source for lower noise operation with option to output the clock
- Selectable hardware conversion trigger
- Automatic compare with interrupt for less-than, greater-than or equal-to, within range, or out-of-range, programmable value
- Temperature sensor
- Hardware average function up to 32×
- Voltage reference: from external
- Self-calibration mode

2.2.3.1 Temperature sensor

This device contains one temperature sensor internally connected to the input channel of AD26, see [Table 66](#) for details of the linearity factor.

The sensor must be calibrated to gain good accuracy, so as to provide good linearity, see also [AN3031](#).

2.2.4 DAC

The 12-bit digital-to-analog converter (DAC) is a low-power, general-purpose DAC. The output of the DAC can be placed on an external pin or set as one of the inputs to the analog comparator, or ADC.

DAC module has the following features:

- On-chip programmable reference generator output. The voltage output range is from $1/4096 V_{in}$ to V_{in} , and the step is $1/4096 V_{in}$, where V_{in} is the input voltage.
- V_{in} can be selected from the reference source V_{DDA}
- Static operation in Normal Stop mode
- 16-word data buffer supported with multiple operation modes
- DMA support

2.2.5 CMP

The device contains one high-speed comparator and two 8-input multiplexers for both the inverting and non-inverting inputs of the comparator. Each CMP input channel connects to both muxes.

The CMP includes one 6-bit DAC, which provides a selectable voltage reference for various user application cases. Besides, the CMP also has several module-to-module interconnects in order to facilitate ADC triggering, TPM triggering, and interfaces.

The CMP has the following features:

- Inputs may range from rail to rail
- Programmable hysteresis control
- Selectable interrupt on rising-edge, falling-edge, or both rising or falling edges of the comparator output
- Selectable inversion on comparator output
- Capability to produce a wide range of outputs such as sampled, digitally filtered
- External hysteresis can be used at the same time that the output filter is used for internal functions
- Two software selectable performance levels: shorter propagation delay at the expense of higher power and Low power with longer propagation delay
- DMA transfer support
- Functional in all modes of operation except in VLLS0 mode
- The filter functions are not available in Stop, VLPS, LLS, or VLLSx modes
- Integrated 6-bit DAC with selectable supply reference source and can be power down to conserve power
- Two 8-to-1 channel mux

2.2.6 RTC

The RTC is an always powered-on block that remains active in all low power modes. The time counter within the RTC is clocked by a 32.768 kHz clock sourced from an external crystal using the RTC oscillator.

RTC is reset on power-on reset, and a software reset bit in RTC can also initialize all RTC registers.

The RTC module has the following features

- 32-bit seconds counter with roll-over protection and 32-bit alarm
- 16-bit prescaler with compensation that can correct errors between 0.12 ppm and 3906 ppm
- Register write protection with register lock mechanism
- 1 Hz square wave or second pulse output with optional interrupt

2.2.7 PIT

The Periodic Interrupt Timer (PIT) is used to generate periodic interrupt to the CPU. It has four independent channels and each channel has a 32-bit counter. Both channels can be chained together to form a 64-bit counter.

Channel 0 can be used to periodically trigger DMA channel 0, and channel 1 can be used to periodically trigger DMA channel 1. Either channel can be programmed as an ADC trigger source, or TPM trigger source. Channel 0 can be programmed to trigger DAC.

The PIT module has the following features:

- Each 32-bit timers is able to generate DMA trigger
- Each 32-bit timers is able to generate timeout interrupts
- Two timers can be cascaded to form a 64-bit timer
- Each timer can be programmed as ADC/TPM trigger source

2.2.8 PDB

The Programmable Delay Block (PDB) provides controllable delays from either an internal or an external trigger, or a programmable interval tick, to the hardware trigger inputs of ADCs and/or generates the interval triggers to DACs, so that the precise

timing between ADC conversions and/or DAC updates can be achieved. The PDB can optionally provide pulse outputs (Pulse-Out's) that are used as the sample window in the CMP block.

The PIT module has the following features:

- Up to 15 trigger input sources and one software trigger source
- Up to 8 configurable PDB channels for ADC hardware trigger
- Up to 8 pulse outputs (pulse-out's)

2.2.9 LPTMR

The low-power timer (LPTMR) can be configured to operate as a time counter with optional prescaler, or as a pulse counter with optional glitch filter, across all power modes, including the low-leakage modes. It can also continue operating through most system reset events, allowing it to be used as a time of day counter.

The LPTMR module has the following features:

- 16-bit time counter or pulse counter with compare
 - Optional interrupt can generate asynchronous wakeup from any low-power mode
 - Hardware trigger output
 - Counter supports free-running mode or reset on compare
- Configurable clock source for prescaler/glitch filter
- Configurable input source for pulse counter

2.2.10 CRC

This device contains one cyclic redundancy check (CRC) module which can generate 16/32-bit CRC code for error detection.

The CRC module provides a programmable polynomial, WAS, and other parameters required to implement a 16-bit or 32-bit CRC standard.

The CRC module has the following features:

- Hardware CRC generator circuit using a 16-bit or 32-bit programmable shift register
- Programmable initial seed value and polynomial
- Option to transpose input data or output data (the CRC result) bitwise or byte-wise.
- Option for inversion of final CRC result
- 32-bit CPU register programming interface

2.2.11 UART

This device contains 3 basic universal asynchronous receiver/transmitter (UART) modules with DMA function supported. Generally, this module is used in RS-232, RS-485, and other communications. It also supports LIN slave operation and ISO7816.

The UART module has the following features:

- Full-duplex operation
- 13-bit baud rate selection with /32 fractional divide, based on the module clock frequency
- Programmable 8-bit or 9-bit data format
- Programmable transmitter output polarity
- Programmable receive input polarity
- Up to 14-bit break character transmission.
- 11-bit break character detection option
- Two receiver wakeup methods with idle line or address mark wakeup
- Address match feature in the receiver to reduce address mark wakeup ISR overhead
- Ability to select MSB or LSB to be the first bit on wire
- UART0 supporting ISO-7816 protocol to interface with SIM cards and smart cards
- Receiver framing error detection
- Hardware parity generation and checking
- 1/16 bit-time noise detection
- DMA interface

2.2.12 LPUART

This device contains one Low-Power UART module, and can work in Stop and VLPS modes. The module also supports 4× to 32× data oversampling rate to meet different applications.

The LPUART module has the following features:

- Programmable baud rates (13-bit modulo divider) with configurable oversampling ratio from 4× to 32×
- Transmit and receive baud rate can operate asynchronous to the bus clock and can be configured independently of the bus clock frequency, support operation in Stop mode

Overview

- Interrupt, DMA or polled operation
- Hardware parity generation and checking
- Programmable 8-bit, 9-bit or 10-bit character length
- Programmable 1-bit or 2-bit stop bits
- Three receiver wakeup methods
 - Idle line wakeup
 - Address mark wakeup
 - Receive data match
- Automatic address matching to reduce ISR overhead:
 - Address mark matching
 - Idle line address matching
 - Address match start, address match end
- Optional 13-bit break character generation / 11-bit break character detection
- Configurable idle length detection supporting 1, 2, 4, 8, 16, 32, 64 or 128 idle characters
- Selectable transmitter output and receiver input polarity

2.2.13 SPI

This device contains two SPI modules. The SPI module provides a synchronous serial bus for communication between a chip and an external peripheral device.

The SPI modules have the following features:

- Full-duplex, three-wire synchronous transfers
- Master mode, or slave mode
- Data streaming operation in Slave mode with continuous slave selection
- Buffered transmit/receive operation using the transmit/receive first in first out (TX/RX FIFO) with depth of 4 entries
- Programmable transfer attributes on a per-frame basis
- Multiple peripheral chip select (PCS) (6 PCS available for SPI0 and 4 PCS for SPI1), expandable to 64 with external demultiplexer
- Deglitching support for up to 32 peripheral chip selects (PCSeS) with external demultiplexer
- DMA support for adding entries to TX FIFO and removing entries from RX FIFO
- Global interrupt request line
- Modified SPI transfer formats for communication with slower peripheral devices
- Power-saving architectural features

2.2.14 FlexCAN

For KS22, the device contains two FlexCAN modules. For KS20, it has only one FlexCAN module. The FlexCAN module is a communication controller implementing the CAN protocol according to the ISO 11898-1 standard and CAN 2.0 B protocol specifications.

The FlexCAN module contains 16 message buffers. Each message buffer is 16 bytes.

The FlexCAN module has the following features:

- Flexible mailboxes of zero to eight bytes data length
- Each mailbox configurable as receive or transmit, all supporting standard and extended messages
- Individual Rx Mask registers per mailbox
- Full-featured Rx FIFO with storage capacity for up to six frames and automatic internal pointer handling with DMA support
- Transmission abort capability
- Programmable clock source to the CAN Protocol Interface, either peripheral clock or oscillator clock
- RAM not used by reception or transmission structures can be used as general purpose RAM space
- Listen-Only mode capability
- Programmable Loop-Back mode supporting self-test operation
- Programmable transmission priority scheme: lowest ID, lowest buffer number, or highest priority
- Time stamp based on 16-bit free-running timer
- Global network time, synchronized by a specific message
- Maskable interrupts
- Independence from the transmission medium (an external transceiver is assumed)
- Short latency time due to an arbitration scheme for high-priority messages
- Low power modes, with programmable wake up on bus activity
- Remote request frames may be handled automatically or by software
- CAN bit time settings and configuration bits can only be written in Freeze mode
- Tx mailbox status (Lowest priority buffer or empty buffer)
- Identifier Acceptance Filter Hit Indicator (IDHIT) register for received frames
- SYNCH bit available in Error in Status 1 register to inform that the module is synchronous with CAN bus
- CRC status for transmitted message
- Rx FIFO Global Mask register

- Selectable priority between mailboxes and Rx FIFO during matching process
- Powerful Rx FIFO ID filtering, capable of matching incoming IDs against either 128 extended, 256 standard, or 512 partial (8 bit) IDs, with up to 32 individual masking capability

2.2.15 LPI2C

This device contains two LPI2C modules. The LPI2C is a low power Inter-Integrated Circuit (I2C) module that supports an efficient interface to an I2C bus as a master and/or a slave. The LPI2C can continue operating in stop modes provided an appropriate clock is available and is designed for low CPU overhead with DMA offloading of FIFO register accesses. The LPI2C implements logic support for standard-mode, fast-mode, fast-mode plus and ultra-fast modes of operation. The LPI2C module also complies with the *System Management Bus (SMBus) Specification, version 2*.

The LPI2C modules have the following features:

- Standard, Fast, Fast+ and Ultra Fast modes are supported
- HS-mode supported in slave mode
- Multi-master support including synchronization and arbitration
- Clock stretching
- General call, 7-bit and 10-bit addressing
- Software reset, START byte and Device ID require software support
- For master mode:
 - command/transmit FIFO of 4 words
 - receive FIFO of 4 words
- For slave mode:
 - separate I2C slave registers to minimize software overhead due to master/slave switching
 - support for 7-bit or 10-bit addressing, address range, SMBus alert and general call address
 - transmit/receive data register supporting interrupt or DMA requests

2.2.16 USB

This device contains one USB full-speed OTG controller. The OTG implementation in this module provides limited host functionality and device solutions for implementing a USB 2.0 full-speed/low-speed compliant peripheral. The OTG logic implements features required by the *On-The-Go and Embedded Host Supplement to the USB 2.0 Specification* (usb.org, 2008). It enables IRC48M to allow crystal-less USB operation.

The USB module has the following features:

- USB 1.1 and 2.0 compatible FS device and FS/LS host controller with OTG protocol logic
- 16 bidirectional end points
- DMA or FIFO data stream interfaces
- Low-power consumption
- IRC48M with clock-recovery is supported to eliminate the 48 MHz crystal. It is used for USB device-only implementation.

2.2.17 I2S

The I2S module provides a synchronous audio interface (SAI), which can be clocked by bus clock, PLL/FLL output clock or external oscillator clock. The module supports asynchronous bit clocks (BCLKs) that can be generated internally from the audio master clock or supplied externally. And also supports the option for synchronous operation between the receiver and transmitter. And it can be functional in stop or very low power mode.

I2S module has the following features:

- Transmitter with independent bit clock and frame sync supporting 1 data channel
- Receiver with independent bit clock and frame sync supporting 1 data channel
- Maximum frame size of 16 words
- Word size of between 8-bits and 32-bits
- Word size configured separately for first word and remaining words in frame
- Asynchronous 8×32 -bit FIFO for each transmit and receive channels
- Supports graceful restart after FIFO error
- Supports automatic restart after FIFO error without software intervention
- Supports packing of 8-bit and 16-bit data into each 32-bit FIFO word

2.2.18 FlexIO

The FlexIO is a highly configurable module providing a wide range of protocols including, but not limited to UART, I2C, SPI, I2S, and PWM/Waveform generation. The module supports programmable baud rates independent of bus clock frequency, with automatic start/stop bit generation.

The FlexIO module has the following features:

- Functional in VLPR/VLPW/Stop/VLPS mode provided the clock it is using remains enabled

Overview

- Four 32-bit double buffered shift registers with transmit, receive, and data match modes, and continuous data transfer
- The timing of the shifter's shift, load and store events are controlled by the highly flexible 16-bit timer assigned to the shifter
- Two or more shifters can be concatenated to support large data transfer sizes
- Each 16-bit timers operates independently, supports for reset, enable and disable on a variety of internal or external trigger conditions with programmable trigger polarity
- Flexible pin configuration supporting output disabled, open drain, bidirectional output data and output mode
- Supports interrupt, DMA or polled transmit/receive operation

2.2.19 Port control and GPIO

The Port Control and Interrupt (PORT) module provides support for port control, digital filtering, and external interrupt functions. The GPIO data direction and output data registers control the direction and output data of each pin when the pin is configured for the GPIO function. The GPIO input data register displays the logic value on each pin when the pin is configured for any digital function, provided the corresponding Port Control and Interrupt module for that pin is enabled.

The following figure shows the basic I/O pad structure. This diagram applies to all I/O pins except RESET_b and those configured as pseudo open-drain outputs. RESET_b is a true open-drain pin without p-channel output driver or diode to the ESD bus. Pseudo open-drain pins have the p-channel output driver disabled when configured for open-drain operation. None of the I/O pins, including open-drain and pseudo open-drain pins, are allowed to go above VDD.

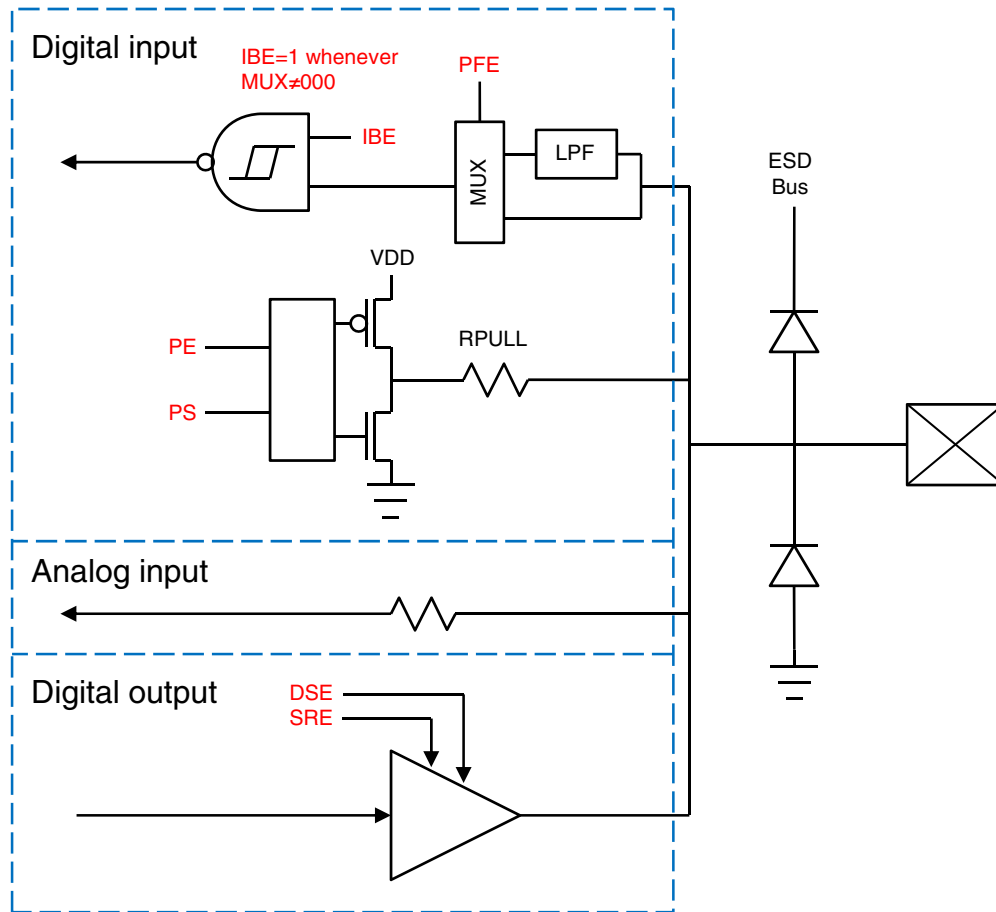

Figure 4. I/O simplified block diagram

The PORT module has the following features:

- all PIN support interrupt enable
- Configurable edge (rising, falling, or both) or level sensitive interrupt type
- Support DMA request
- Asynchronous wake-up in low-power modes
- Configurable pullup, pulldown, and pull-disable on select pins
- Configurable high and low drive strength on selected pins
- Configurable fast and slow slew rates on selected pins
- Configurable passive filter on selected pins
- Individual mux control field supporting analog or pin disabled, GPIO, and up to chip-specific digital functions
- Pad configuration fields are functional in all digital pin muxing modes.

The GPIO module has the following features:

- Port Data Input register visible in all digital pin-multiplexing modes
- Port Data Output register with corresponding set/clear/toggle registers

Memory map

- Port Data Direction register
- GPIO support single-cycle access via fast GPIO.

3 Memory map

This device contains various memories and memory-mapped peripherals which are located in a 4 GB memory space. For more details of the system memory and peripheral locations, see the Memory Map chapter in the Reference Manual.

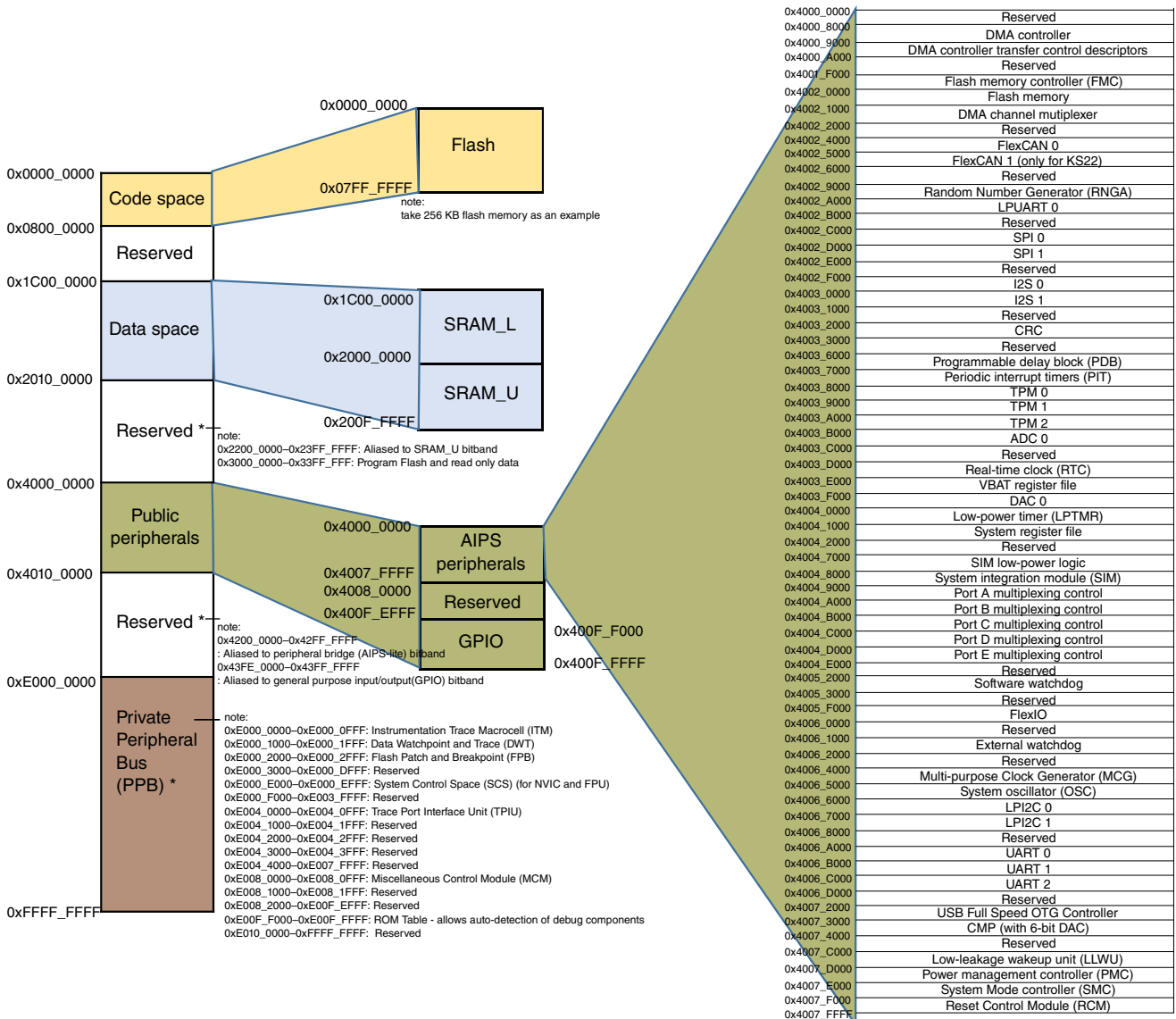

Figure 5. Memory map

4 Pinouts

4.1 Signal Multiplexing and Pin Assignments

The following table shows the signals available on each pin and the locations of these pins on the devices supported by this document. The Port Control Module is responsible for selecting which ALT functionality is available on each pin.

NOTE

For KS20, only CAN0 exists. For KS22, there are two instances of CAN module (CAN0 and CAN1).

100 LQFP	64 LQFP	48 QFN	Pin Name	Default	ALT0	ALT1	ALT2	ALT3	ALT4	ALT5	ALT6	ALT7
1	1	1	PTE0/ CLKOUT32K	ADC0_SE4a	ADC0_SE4a	PTE0/ CLKOUT32K	SPI1_PCS1	UART1_TX			LPI2C1_SDA	RTC_ CLKOUT
2	2	2	PTE1/ LLWU_P0	ADC0_SE5a	ADC0_SE5a	PTE1/ LLWU_P0	SPI1_SOUT	UART1_RX			LPI2C1_SCL	SPI1_SIN
3	—	3	PTE2/ LLWU_P1	ADC0_SE6a	ADC0_SE6a	PTE2/ LLWU_P1	SPI1_SCK	UART1_ CTS_b				
4	—	4	PTE3	ADC0_SE7a	ADC0_SE7a	PTE3	SPI1_SIN	UART1_ RTS_b				SPI1_SOUT
5	—	5	PTE4/ LLWU_P2	DISABLED		PTE4/ LLWU_P2	SPI1_PCS0	LPUART0_ TX				LPI2C1_SDA
6	—	6	PTE5	DISABLED		PTE5	SPI1_PCS2	LPUART0_ RX				LPI2C1_SCL
7	—	—	PTE6	DISABLED		PTE6	SPI1_PCS3	LPUART0_ CTS_b	I2S0_MCLK			USB_SOF_ OUT
8	3	7	VDD	VDD	VDD							
9	4	8	VSS	VSS	VSS							
10	5	9	USB0_DP	USB0_DP	USB0_DP							
11	6	10	USB0_DM	USB0_DM	USB0_DM							
12	7	11	USBVDD	USBVDD	USBVDD							
13	—	—	NC	NC	NC							
14	8	—	ADC0_DP1	ADC0_DP1	ADC0_DP1							
15	—	—	ADC0_DM1	ADC0_DM1	ADC0_DM1							
16	—	—	ADC0_DP2	ADC0_DP2	ADC0_DP2							
17	—	—	ADC0_DM2	ADC0_DM2	ADC0_DM2							
18	9	—	ADC0_DP0	ADC0_DP0	ADC0_DP0							
19	10	—	ADC0_DM0	ADC0_DM0	ADC0_DM0							
20	11	—	ADC0_DP3	ADC0_DP3	ADC0_DP3							

Pinouts

100 LQFP	64 LQFP	48 QFN	Pin Name	Default	ALT0	ALT1	ALT2	ALT3	ALT4	ALT5	ALT6	ALT7
21	12	—	ADC0_DM3	ADC0_DM3	ADC0_DM3							
22	13	12	VDDA	VDDA	VDDA							
23	14	12	VREFH	VREFH	VREFH							
24	15	13	VREFL	VREFL	VREFL							
25	16	13	VSSA	VSSA	VSSA							
26	17	—	CMP0_IN5	CMP0_IN5	CMP0_IN5							
27	18	—	DAC0_OUT/ ADC0_SE23	DAC0_OUT/ ADC0_SE23	DAC0_OUT/ ADC0_SE23							
28	19	14	XTAL32	XTAL32	XTAL32							
29	20	15	EXTAL32	EXTAL32	EXTAL32							
30	21	16	VBAT	VBAT	VBAT							
31	—	—	PTE24	ADC0_SE17	ADC0_SE17	PTE24	CAN1_TX	TPM0_CH0	I2S1_TX_FS	LPI2C0_SCL	EWM_OUT_b	
32	—	—	PTE25	ADC0_SE18	ADC0_SE18	PTE25	CAN1_RX	TPM0_CH1	I2S1_TX_ BCLK	LPI2C0_SDA	EWM_IN	
33	—	—	PTE26/ CLKOUT32K	DISABLED		PTE26/ CLKOUT32K			I2S1_TXD0		RTC_ CLKOUT	USB_CLKIN
34	22	17	PTA0	JTAG_TCLK/ SWD_CLK		PTA0	UART0_ CTS_b	TPM0_CH5		EWM_IN		JTAG_TCLK/ SWD_CLK
35	23	18	PTA1	JTAG_TDI		PTA1	UART0_RX		CMP0_OUT	LPI2C1_ HREQ	TPM1_CH1	JTAG_TDI
36	24	19	PTA2	JTAG_TDO/ TRACE_ SWO		PTA2	UART0_TX				TPM1_CH0	JTAG_TDO/ TRACE_ SWO
37	25	20	PTA3	JTAG_TMS/ SWD_DIO		PTA3	UART0_ RTS_b	TPM0_CH0		EWM_OUT_b		JTAG_TMS/ SWD_DIO
38	26	21	PTA4/ LLWU_P3	NMI_b		PTA4/ LLWU_P3		TPM0_CH1			I2S0_MCLK	NMI_b
39	27	—	PTA5	DISABLED		PTA5	USB_CLKIN	TPM0_CH2			I2S0_TX_ BCLK	JTAG_TRST_ b
40	—	—	VDD	VDD	VDD							
41	—	—	VSS	VSS	VSS							
42	28	—	PTA12	DISABLED		PTA12	CAN0_TX	TPM1_CH0			I2S0_TXD0	
43	29	—	PTA13/ LLWU_P4	DISABLED		PTA13/ LLWU_P4	CAN0_RX	TPM1_CH1			I2S0_TX_FS	
44	—	—	PTA14	DISABLED		PTA14	SPIO_PCS0	UART0_TX			I2S0_RX_ BCLK	
45	—	—	PTA15	DISABLED		PTA15	SPIO_SCK	UART0_RX			I2S0_RXD0	
46	—	—	PTA16	DISABLED		PTA16	SPIO_SOUT	UART0_ CTS_b			I2S0_RX_FS	
47	—	—	PTA17	DISABLED		PTA17	SPIO_SIN	UART0_ RTS_b			I2S0_MCLK	
48	30	22	VDD	VDD	VDD							
49	31	23	VSS	VSS	VSS							
50	32	24	PTA18	EXTAL0	EXTAL0	PTA18			TPM_CLKIN0			

100 LQFP	64 LQFP	48 QFN	Pin Name	Default	ALT0	ALT1	ALT2	ALT3	ALT4	ALT5	ALT6	ALT7
51	33	25	PTA19	XTAL0	XTAL0	PTA19			TPM_CLKIN1		LPTMR0_ALT1	
52	34	26	RESET_b	RESET_b	RESET_b							
53	35	27	PTB0/LLWU_P5	ADC0_SE8	ADC0_SE8	PTB0/LLWU_P5	LPI2C0_SCL	TPM1_CH0			FXIO0_D4	UART0_RX
54	36	28	PTB1	ADC0_SE9	ADC0_SE9	PTB1	LPI2C0_SDA	TPM1_CH1		EWM_IN	FXIO0_D5	UART0_TX
55	37	29	PTB2	ADC0_SE12	ADC0_SE12	PTB2	LPI2C0_SCL	UART0_RTS_b			FXIO0_D6	CAN1_RX
56	38	30	PTB3	ADC0_SE13	ADC0_SE13	PTB3	LPI2C0_SDA	UART0_CTS_b			FXIO0_D7	CAN1_TX
57	—	—	PTB9	DISABLED		PTB9	SPI1_PCS1	LPUART0_CTS_b				
58	—	—	PTB10	DISABLED		PTB10	SPI1_PCS0	LPUART0_RX	I2S1_TX_BCLK			
59	—	—	PTB11	DISABLED		PTB11	SPI1_SCK	LPUART0_TX	I2S1_TX_FS			
60	—	—	VSS	VSS	VSS							
61	—	—	VDD	VDD	VDD							
62	39	31	PTB16	DISABLED		PTB16	SPI1_SOUT	UART0_RX	TPM_CLKIN0		EWM_IN	I2S1_TXD0 (Note: 100LQFP only)
63	40	—	PTB17	DISABLED		PTB17	SPI1_SIN	UART0_TX	TPM_CLKIN1		EWM_OUT_b	FXIO0_D0
64	41	32	PTB18	DISABLED		PTB18	CAN0_TX	TPM2_CH0	I2S0_TX_BCLK			FXIO0_D1
65	42	33	PTB19	DISABLED		PTB19	CAN0_RX	TPM2_CH1	I2S0_TX_FS			FXIO0_D2
66	—	—	PTB20	DISABLED		PTB20					CMP0_OUT	FXIO0_D4
67	—	—	PTB21	DISABLED		PTB21					FXIO0_D5	
68	—	—	PTB22	DISABLED		PTB22					FXIO0_D6	
69	—	—	PTB23	DISABLED		PTB23		SPI0_PCS5			FXIO0_D7	
70	43	—	PTC0	ADC0_SE14	ADC0_SE14	PTC0	SPI0_PCS4	PDB0_EXTRG	USB_SOF_OUT		FXIO0_D3	SPI0_PCS0
71	44	34	PTC1/LLWU_P6	ADC0_SE15	ADC0_SE15	PTC1/LLWU_P6	SPI0_PCS3	UART1_RTS_b	TPM0_CH0		I2S0_TXD0	LPUART0_RTS_b
72	45	35	PTC2	ADC0_SE4b	ADC0_SE4b	PTC2	SPI0_PCS2	UART1_CTS_b	TPM0_CH1		I2S0_TX_FS	LPUART0_CTS_b
73	46	36	PTC3/LLWU_P7	DISABLED		PTC3/LLWU_P7	SPI0_PCS1	UART1_RX	TPM0_CH2	CLKOUT	I2S0_TX_BCLK	LPUART0_RX
74	47	—	VSS	VSS	VSS							
75	48	—	VDD	VDD	VDD							
76	49	37	PTC4/LLWU_P8	DISABLED		PTC4/LLWU_P8	SPI0_PCS0	UART1_TX	TPM0_CH3		LPI2C0_HREQ	LPUART0_TX
77	50	38	PTC5/LLWU_P9	DISABLED		PTC5/LLWU_P9	SPI0_SCK	LPTMR0_ALT2	I2S0_RXD0		CMP0_OUT	TPM0_CH2

Pinouts

100 LQFP	64 LQFP	48 QFN	Pin Name	Default	ALT0	ALT1	ALT2	ALT3	ALT4	ALT5	ALT6	ALT7
78	51	39	PTC6/ LLWU_P10	CMP0_IN0	CMP0_IN0	PTC6/ LLWU_P10	SPI0_SOUT	PDB0_ EXTRG	I2S0_RX_ BCLK		I2S0_MCLK	LPI2C0_SCL
79	52	40	PTC7	CMP0_IN1	CMP0_IN1	PTC7	SPI0_SIN	USB_SOF_ OUT	I2S0_RX_FS			LPI2C0_SDA
80	53	—	PTC8	CMP0_IN2	CMP0_IN2	PTC8	LPI2C0_ SCLS		I2S0_MCLK		FXIO0_D0	I2S1_RXD0
81	54	—	PTC9	CMP0_IN3	CMP0_IN3	PTC9	LPI2C0_ SDAS		I2S0_RX_ BCLK		FXIO0_D1	I2S1_RX_ BCLK
82	55	—	PTC10	DISABLED		PTC10	LPI2C1_SCL		I2S0_RX_FS		FXIO0_D2	I2S1_RX_FS
83	56	—	PTC11/ LLWU_P11	DISABLED		PTC11/ LLWU_P11	LPI2C1_SDA				FXIO0_D3	I2S1_MCLK
84	—	—	PTC12	DISABLED		PTC12	LPI2C1_ SCLS		TPM_CLKIN0			FXIO0_D0
85	—	—	PTC13	DISABLED		PTC13	LPI2C1_ SDAS		TPM_CLKIN1			FXIO0_D1
86	—	—	PTC14	DISABLED		PTC14			LPUART0_ RTS_b			FXIO0_D2
87	—	—	PTC15	DISABLED		PTC15			LPUART0_ CTS_b			FXIO0_D3
88	—	—	VSS	VSS	VSS							
89	—	—	VDD	VDD	VDD							
90	—	—	PTC16	DISABLED		PTC16	CAN1_RX	LPUART0_ RX				FXIO0_D4
91	—	—	PTC17	DISABLED		PTC17	CAN1_TX	LPUART0_ TX				FXIO0_D5
92	—	—	PTC18	DISABLED		PTC18		LPUART0_ RTS_b				
93	57	41	PTD0/ LLWU_P12	DISABLED		PTD0/ LLWU_P12	SPI0_PCS0	UART2_ RTS_b			LPUART0_ RTS_b	FXIO0_D6
94	58	42	PTD1	ADC0_SE5b	ADC0_SE5b	PTD1	SPI0_SCK	UART2_ CTS_b			LPUART0_ CTS_b	FXIO0_D7
95	59	43	PTD2/ LLWU_P13	DISABLED		PTD2/ LLWU_P13	SPI0_SOUT	UART2_RX			LPUART0_ RX	LPI2C0_SCL
96	60	44	PTD3	DISABLED		PTD3	SPI0_SIN	UART2_TX			LPUART0_ TX	LPI2C0_SDA
97	61	45	PTD4/ LLWU_P14	DISABLED		PTD4/ LLWU_P14	SPI0_PCS1	UART0_ RTS_b	TPM0_CH4		EWM_IN	SPI1_PCS0
98	62	46	PTD5	ADC0_SE6b	ADC0_SE6b	PTD5	SPI0_PCS2	UART0_ CTS_b	TPM0_CH5		EWM_OUT_b	SPI1_SCK
99	63	47	PTD6/ LLWU_P15	ADC0_SE7b	ADC0_SE7b	PTD6/ LLWU_P15	SPI0_PCS3	UART0_RX				SPI1_SOUT
100	64	48	PTD7	DISABLED		PTD7		UART0_TX				SPI1_SIN

4.2 Pin properties

The following table lists the pin properties.

100LQFP	64LQFP	48QFN	Pin Name	Driver Strength	Default Status after POR	Pull-up/pull-down Setting after POR	Slew Rate after POR	Passive Pin Filter after POR	Open Drain	Pin Interrupt
1	1	1	PTE0/CLKOUT32K	ND	Hi-Z	-	FS	N	N	Y
2	2	2	PTE1/LLWU_P0	ND	Hi-Z	-	FS	N	N	Y
3		3	PTE2/LLWU_P1	ND	Hi-Z	-	FS	N	N	Y
4		4	PTE3	ND	Hi-Z	-	FS	N	N	Y
5		5	PTE4/LLWU_P2	ND	Hi-Z	-	FS	N	N	Y
6		6	PTE5	ND	Hi-Z	-	FS	N	N	Y
7			PTE6	ND	Hi-Z	-	FS	N	N	Y
8	3	7	VDD	-	-	-	-	-	-	-
9	4	8	VSS	-	-	-	-	-	-	-
10	5	9	USB0_DP	-	Hi-Z	-	-	-	-	-
11	6	10	USB0_DM	-	Hi-Z	-	-	-	-	-
12	7	11	USBVDD	-	-	-	-	-	-	-
13			NC	-	-	-	-	-	-	-
14	8		ADC0_DP1	-	Hi-Z	-	-	-	-	-
15			ADC0_DM1	-	Hi-Z	-	-	-	-	-
16			ADC0_DP2	-	Hi-Z	-	-	-	-	-
17			ADC0_DM2	-	Hi-Z	-	-	-	-	-
18	9		ADC0_DP0	-	Hi-Z	-	-	-	-	-
19	10		ADC0_DM0	-	Hi-Z	-	-	-	-	-
20	11		ADC0_DP3	-	Hi-Z	-	-	-	-	-

Table continues on the next page...

Pinouts

100LQFP	64LQFP	48QFN	Pin Name	Driver Strength	Default Status after POR	Pull-up/pull-down Setting after POR	Slew Rate after POR	Passive Pin Filter after POR	Open Drain	Pin Interrupt
21	12		ADC0_DM3	-	Hi-Z	-	-	-	-	-
22	13	12	VDDA	-	-	-	-	-	-	-
23	14	12	VREFH	-	Hi-Z	-	-	-	-	-
24	15	13	VREFL	-	Hi-Z	-	-	-	-	-
25	16	13	VSSA	-	Hi-Z	-	-	-	-	-
26	17		CMP0_IN5	-	Hi-Z	-	-	-	-	-
27	18		DAC0_OUT/ ADC0_SE23	-	Hi-Z	-	-	-	-	-
28	19	14	XTAL32	-	Hi-Z	-	-	-	-	-
29	20	15	EXTAL32	-	Hi-Z	-	-	-	-	-
30	21	16	VBAT	-	-	-	-	-	-	-
31			PTE24	ND	Hi-Z	-	FS	N	N	Y
32			PTE25	ND	Hi-Z	-	FS	N	N	Y
33			PTE26/ CLKOUT 32K	ND	Hi-Z	-	FS	N	N	Y
34	22	17	PTA0	ND	L	PD	FS	N	N	Y
35	23	18	PTA1	ND	H	PU	FS	N	N	Y
36	24	19	PTA2	ND	H	PU	FS	N	N	Y
37	25	20	PTA3	ND	H	PU	FS	N	N	Y
38	26	21	PTA4/ LLWU_P 3	ND	H	PU	FS	N	N	Y
39	27		PTA5	ND	Hi-Z	-	FS	N	N	Y
40			VDD	-	-	-	-	-	-	-
41			VSS	-	-	-	-	-	-	-
42	28		PTA12	ND	Hi-Z	-	FS	N	N	Y
43	29		PTA13/ LLWU_P 4	ND	Hi-Z	-	FS	N	N	Y
44			PTA14	ND	Hi-Z	-	FS	N	N	Y
45			PTA15	ND	Hi-Z	-	FS	N	N	Y
46			PTA16	ND	Hi-Z	-	FS	N	N	Y
47			PTA17	ND	Hi-Z	-	FS	N	N	Y
48	30	22	VDD	-	-	-	-	-	-	-

Table continues on the next page...

100LQFP	64LQFP	48QFN	Pin Name	Driver Strength	Default Status after POR	Pull-up/pull-down Setting after POR	Slew Rate after POR	Passive Pin Filter after POR	Open Drain	Pin Interrupt
49	31	23	VSS	-	-	-	-	-	-	-
50	32	24	PTA18	ND	Hi-Z	-	FS	N	N	Y
51	33	25	PTA19	ND	Hi-Z	-	FS	N	N	Y
52	34	26	RESET_b	-	H	PU	-	Y	N	-
53	35	27	PTB0/LLWU_P5	HD	Hi-Z	-	FS	N	N	Y
54	36	28	PTB1	HD	Hi-Z	-	FS	N	N	Y
55	37	29	PTB2	ND	Hi-Z	-	FS	N	N	Y
56	38	30	PTB3	ND	Hi-Z	-	FS	N	N	Y
57			PTB9	ND	Hi-Z	-	FS	N	N	Y
58			PTB10	ND	Hi-Z	-	FS	N	N	Y
59			PTB11	ND	Hi-Z	-	FS	N	N	Y
60			VSS	-	-	-	-	-	-	-
61			VDD	-	-	-	-	-	-	-
62	39	31	PTB16	ND	Hi-Z	-	FS	N	N	Y
63	40		PTB17	ND	Hi-Z	-	FS	N	N	Y
64	41	32	PTB18	ND	Hi-Z	-	FS	N	N	Y
65	42	33	PTB19	ND	Hi-Z	-	FS	N	N	Y
66			PTB20	ND	Hi-Z	-	FS	N	N	Y
67			PTB21	ND	Hi-Z	-	FS	N	N	Y
68			PTB22	ND	Hi-Z	-	FS	N	N	Y
69			PTB23	ND	Hi-Z	-	FS	N	N	Y
70	43		PTC0	ND	Hi-Z	-	FS	N	N	Y
71	44	34	PTC1/LLWU_P6	ND	Hi-Z	-	FS	N	N	Y
72	45	35	PTC2	ND	Hi-Z	-	FS	N	N	Y
73	46	36	PTC3/LLWU_P7	HD	Hi-Z	-	FS	N	N	Y
74	47		VSS	-	-	-	-	-	-	-
75	48		VDD	-	-	-	-	-	-	-
76	49	37	PTC4/LLWU_P8	HD	Hi-Z	-	FS	N	N	Y

Table continues on the next page...

Pinouts

100LQFP	64LQFP	48QFN	Pin Name	Driver Strength	Default Status after POR	Pull-up/pull-down Setting after POR	Slew Rate after POR	Passive Pin Filter after POR	Open Drain	Pin Interrupt
77	50	38	PTC5/LLWU_P9	ND	Hi-Z	-	FS	N	N	Y
78	51	39	PTC6/LLWU_P10	ND	Hi-Z	-	FS	N	N	Y
79	52	40	PTC7	ND	Hi-Z	-	FS	N	N	Y
80	53		PTC8	ND	Hi-Z	-	FS	N	N	Y
81	54		PTC9	ND	Hi-Z	-	FS	N	N	Y
82	55		PTC10	ND	Hi-Z	-	FS	N	N	Y
83	56		PTC11/LLWU_P11	ND	Hi-Z	-	FS	N	N	Y
84			PTC12	ND	Hi-Z	-	FS	N	N	Y
85			PTC13	ND	Hi-Z	-	FS	N	N	Y
86			PTC14	ND	Hi-Z	-	FS	N	N	Y
87			PTC15	ND	Hi-Z	-	FS	N	N	Y
88			VSS	-	-	-	-	-	-	-
89			VDD	-	-	-	-	-	-	-
90			PTC16	ND	Hi-Z	-	FS	N	N	Y
91			PTC17	ND	Hi-Z	-	FS	N	N	Y
92			PTC18	ND	Hi-Z	-	FS	N	N	Y
93	57	41	PTD0/LLWU_P12	ND	Hi-Z	-	FS	N	N	Y
94	58	42	PTD1	ND	Hi-Z	-	FS	N	N	Y
95	59	43	PTD2/LLWU_P13	ND	Hi-Z	-	FS	N	N	Y
96	60	44	PTD3	ND	Hi-Z	-	FS	N	N	Y
97	61	45	PTD4/LLWU_P14	HD	Hi-Z	-	FS	N	N	Y
98	62	46	PTD5	HD	Hi-Z	-	FS	N	N	Y
99	63	47	PTD6/LLWU_P15	HD	Hi-Z	-	FS	N	N	Y
100	64	48	PTD7	HD	Hi-Z	-	FS	N	N	Y

Properties	Abbreviation	Descriptions
Driver strength	ND	Normal drive
	HD	High drive
Default status after POR	Hi-Z	High impedance
	H	High level
	L	Low level
Pull-up/pull-down setting after POR	PU	Pull-up
	PD	Pull-down
Slew rate after POR	FS	Fast slew rate
	SS	Slow slew rate
Passive Pin Filter after POR	N	Disabled
	Y	Enabled
Open drain	N	Disabled ¹
	Y	Enabled
Pin interrupt	Y	Yes

1. When UART or LPUART module is enabled and a pin is functional for UART or LPUART, this pin is (pseudo-) open drain configurable.

4.3 Module Signal Description Tables

The following sections correlate the chip-level signal name with the signal name used in the module's chapter. They also briefly describe the signal function and direction.

4.3.1 Core Modules

Table 9. JTAG Signal Descriptions

Chip signal name	Module signal name	Description	I/O
JTAG_TMS	JTAG_TMS/ SWD_DIO	JTAG Test Mode Selection	I
JTAG_TCLK	JTAG_TCLK/ SWD_CLK	JTAG Test Clock	I
JTAG_TDI	JTAG_TDI	JTAG Test Data Input	I
JTAG_TDO	JTAG_TDO/ TRACE_SWO	JTAG Test Data Output	O
JTAG_TRST	JTAG_TRST_b	JTAG Reset	I

Table 10. SWD Signal Descriptions

Chip signal name	Module signal name	Description	I/O
SWD_DIO	JTAG_TMS/ SWD_DIO	Serial Wire Data	I
SWD_CLK	JTAG_TCLK/ SWD_CLK	Serial Wire Clock	I

Table 11. TPIU Signal Descriptions

Chip signal name	Module signal name	Description	I/O
TRACE_SWO	JTAG_TDO/ TRACE_SWO	Trace output data from the Arm CoreSight debug block over a single pin	O

4.3.2 System Modules

Table 12. EWM Signal Descriptions

Chip signal name	Module signal name	Description	I/O
EWM_IN	EWM_in	EWM input for safety status of external safety circuits. The polarity of EWM_in is programmable using the EWM_CTRL[ASSIN] bit. The default polarity is active-low.	I
EWM_OUT	EWM_out	EWM reset out signal	O

4.3.3 Clock Modules

Table 13. OSC Signal Descriptions

Chip signal name	Module signal name	Description	I/O
EXTAL0	EXTAL	External clock/Oscillator input	I
XTAL0	XTAL	Oscillator output	O

Table 14. RTC OSC Signal Descriptions

Chip signal name	Module signal name	Description	I/O
EXTAL32	EXTAL32	32.768 kHz oscillator input	I
XTAL32	XTAL32	32.768 kHz oscillator output	O

4.3.4 Analog

Table 15. ADC 0 Signal Descriptions

Chip signal name	Module signal name	Description	I/O
ADC0_DP[3:0]	DADP3–DADP0	Differential Analog Channel Inputs	I
ADC0_DM[3:0]	DADM3–DADM0	Differential Analog Channel Inputs	I
ADC0_SE n	AD n	Single-Ended Analog Channel Inputs	I
VREFH	V _{REFSH}	Voltage Reference Select High	I
VREFL	V _{REFSL}	Voltage Reference Select Low	I
VDDA	V _{DDA}	Analog Power Supply	I
VSSA	V _{SSA}	Analog Ground	I

Table 16. CMP 0 Signal Descriptions

Chip signal name	Module signal name	Description	I/O
CMP0_IN[5:0]	IN[5:0]	Analog voltage inputs	I
CMP0_OUT	CMPO	Comparator output	O

Table 17. DAC 0 Signal Descriptions

Chip signal name	Module signal name	Description	I/O
DAC0_OUT	—	DAC output	O

4.3.5 Timer Modules

Table 18. PDB 0 Signal Descriptions

Chip signal name	Module signal name	Description	I/O
PDB0_EXTRG	EXTRG	External Trigger Input Source If the PDB is enabled and external trigger input source is selected, a positive edge on the EXTRG signal resets and starts the counter.	I

Table 19. LPTMR 0 Signal Descriptions

Chip signal name	Module signal name	Description	I/O
LPTMR0_ALT[2:1]	LPTMR0_ALTn	Pulse Counter Input pin	I

Table 20. RTC Signal Descriptions

Chip signal name	Module signal name	Description	I/O
VBAT	—	Backup battery supply for RTC and VBAT register file	I
RTC_CLKOUT	RTC_CLKOUT	1 Hz square-wave output or OSCERCLK	O

Table 21. TPM 0 Signal Descriptions

Chip signal name	Module signal name	Description	I/O
TPM_CLKIN[1:0]	TPM_EXTCLK	External clock. TPM external clock can be selected to increment the TPM counter on every rising edge synchronized to the counter clock.	I
TPM0_CH[5:0]	TPM_CHn	TPM channel (n = 5 to 0). A TPM channel pin is configured as output when configured in an output compare or PWM mode and the TPM counter is enabled, otherwise the TPM channel pin is an input.	I/O

Table 22. TPM 1 Signal Descriptions

Chip signal name	Module signal name	Description	I/O
TPM_CLKIN[1:0]	TPM_EXTCLK	External clock. TPM external clock can be selected to increment the TPM counter on every rising edge synchronized to the counter clock.	I
TPM1_CH[1:0]	TPM_CHn	TPM channel (n = 5 to 0). A TPM channel pin is configured as output when configured in an output compare or PWM mode and the TPM counter is enabled, otherwise the TPM channel pin is an input.	I/O

Table 23. TPM 2 Signal Descriptions

Chip signal name	Module signal name	Description	I/O
TPM_CLKIN[1:0]	TPM_EXTCLK	External clock. TPM external clock can be selected to increment the TPM counter on every rising edge synchronized to the counter clock.	I

Table continues on the next page...

Table 23. TPM 2 Signal Descriptions (continued)

Chip signal name	Module signal name	Description	I/O
TPM2_CH[1:0]	TPM_CHn	TPM channel (n = 5 to 0). A TPM channel pin is configured as output when configured in an output compare or PWM mode and the TPM counter is enabled, otherwise the TPM channel pin is an input.	I/O

4.3.6 Communication Interfaces

Table 24. USB FS OTG Signal Descriptions

Chip signal name	Module signal name	Description	I/O
USB0_DM	usb_dm	USB D- analog data signal on the USB bus.	I/O
USB0_DP	usb_dp	USB D+ analog data signal on the USB bus.	I/O
USB_CLKIN	—	Alternate USB clock input	I
USB_SOF_OUT	—	USB start of frame signal. Can be used to make the USB start of frame available for external synchronization.	O

Table 25. CAN 0 Signal Descriptions

Chip signal name	Module signal name	Description	I/O
CAN0_RX	CAN Rx	CAN Receive Pin	Input
CAN0_TX	CAN Tx	CAN Transmit Pin	Output

Table 26. CAN 1 (for KS22 only) Signal Descriptions

Chip signal name	Module signal name	Description	I/O
CAN1_RX	CAN Rx	CAN Receive Pin	Input
CAN1_TX	CAN Tx	CAN Transmit Pin	Output

Table 27. SPI 0 Signal Descriptions

Chip signal name	Module signal name	Description	I/O
SPI0_PCS0	PCS0/ \overline{SS}	Peripheral Chip Select 0 (O)	I/O
SPI0_PCS[3:1]	PCS[1:3]	Peripheral Chip Selects 1–3	O
SPI0_PCS4	PCS4	Peripheral Chip Select 4	O

Table continues on the next page...

Table 27. SPI 0 Signal Descriptions (continued)

Chip signal name	Module signal name	Description	I/O
SPI0_PCS5	PCS5/ PCSS	Peripheral Chip Select 5 /Peripheral Chip Select Strobe	O
SPI0_SIN	SIN	Serial Data In	I
SPI0_SOUT	SOUT	Serial Data Out	O
SPI0_SCK	SCK	Serial Clock (O)	I/O

Table 28. SPI 1 Signal Descriptions

Chip signal name	Module signal name	Description	I/O
SPI1_PCS0	PCS0/SS	Peripheral Chip Select 0 (O)	I/O
SPI1_PCS[3:1]	PCS[1:3]	Peripheral Chip Selects 1–3	O
SPI1_SIN	SIN	Serial Data In	I
SPI1_SOUT	SOUT	Serial Data Out	O
SPI1_SCK	SCK	Serial Clock (O)	I/O

Table 29. LPI²C 0 Signal Descriptions

Chip signal name	Module signal name	Description	I/O
LPI2C0_SCL	SCL	LPI2C clock line.	I/O
LPI2C0_SDA	SDA	LPI2C data line.	I/O
LPI2C0_HREQ	HREQ	Host request, can initiate an LPI2C master transfer if asserted and the I2C bus is idle.	I
LPI2C0_SCLS	SCLS	Secondary I2C clock line. If LPI2C master/slave are configured to use separate pins, this the LPI2C slave SCL pin.	I/O
LPI2C0_SDAS	SDAS	Secondary I2C data line. If LPI2C master/slave are configured to use separate pins, this the LPI2C slave SDA pin.	I/O

Table 30. LPI²C 1 Signal Descriptions

Chip signal name	Module signal name	Description	I/O
LPI2C1_SCL	SCL	LPI2C clock line.	I/O
LPI2C1_SDA	SDA	LPI2C data line.	I/O
LPI2C1_HREQ	HREQ	Host request, can initiate an LPI2C master transfer if asserted and the I2C bus is idle.	I
LPI2C1_SCLS	SCLS	Secondary I2C clock line. If LPI2C master/slave are configured to use separate pins, this the LPI2C slave SCL pin.	I/O
LPI2C1_SDAS	SDAS	Secondary I2C data line. If LPI2C master/slave are configured to use separate pins, this the LPI2C slave SDA pin.	I/O

Table 31. LPUART Signal Descriptions

Chip signal name	Module signal name	Description	I/O
LPUART0_TX	LPUART_TX	Transmit data. This pin is normally an output, but is an input (tristated) in single wire mode whenever the transmitter is disabled or transmit direction is configured for receive data.	O/I
LPUART0_RX	LPUART_RX	Receive data	I
LPUART0_CTS	LPUART_CTS	Clear to send	I
$\overline{\text{LPUART0_CTS}}$	LPUART_RTS	Request to send	I

Table 32. UART 0 Signal Descriptions

Chip signal name	Module signal name	Description	I/O
UART0_CTS	$\overline{\text{CTS}}$	Clear to send	I
UART0_RTS	$\overline{\text{RTS}}$	Request to send	O
UART0_TX	TXD	Transmit data	O
UART0_RX	RXD	Receive data	I

Table 33. UART 1 Signal Descriptions

Chip signal name	Module signal name	Description	I/O
UART1_CTS	$\overline{\text{CTS}}$	Clear to send	I
$\overline{\text{UART1_RTS}}$	$\overline{\text{RTS}}$	Request to send	O
UART1_TX	TXD	Transmit data	O
UART1_RX	RXD	Receive data	I

Table 34. UART 2 Signal Descriptions

Chip signal name	Module signal name	Description	I/O
$\overline{\text{UART2_CTS}}$	$\overline{\text{CTS}}$	Clear to send	I
UART2_RTS	$\overline{\text{RTS}}$	Request to send	O
UART2_TX	TXD	Transmit data	O
UART2_RX	RXD	Receive data	I

Table 35. I²S0 Signal Descriptions

Chip signal name	Module signal name	Description	I/O
I2S0_MCLK	SAI_MCLK	Audio Master Clock. The master clock is an input when externally generated and an output when internally generated.	I/O
I2S0_RX_BCLK	SAI_RX_BCLK	Receive Bit Clock. The bit clock is an input when externally generated and an output when internally generated.	I/O
I2S0_RX_FS	SAI_RX_SYNC	Receive Frame Sync. The frame sync is an input sampled synchronously by the bit clock when externally generated and an output generated synchronously by the bit clock when internally generated.	I/O
I2S0_RXD	SAI_RX_DATA	Receive Data. The receive data is sampled synchronously by the bit clock.	I
I2S0_TX_BCLK	SAI_TX_BCLK	Transmit Bit Clock. The bit clock is an input when externally generated and an output when internally generated.	I/O
I2S0_TX_FS	SAI_TX_SYNC	Transmit Frame Sync. The frame sync is an input sampled synchronously by the bit clock when externally generated and an output generated synchronously by the bit clock when internally generated.	I/O
I2S0_TXD	SAI_TX_DATA	Transmit Data. The transmit data is generated synchronously by the bit clock and is tristated whenever not transmitting a word.	O

Table 36. I²S1 Signal Descriptions

Chip signal name	Module signal name	Description	I/O
I2S1_MCLK	SAI_MCLK	Audio Master Clock. The master clock is an input when externally generated and an output when internally generated.	I/O
I2S1_RX_BCLK	SAI_RX_BCLK	Receive Bit Clock. The bit clock is an input when externally generated and an output when internally generated.	I/O
I2S1_RX_FS	SAI_RX_SYNC	Receive Frame Sync. The frame sync is an input sampled synchronously by the bit clock when externally generated and an output generated synchronously by the bit clock when internally generated.	I/O
I2S1_RXD	SAI_RX_DATA	Receive Data. The receive data is sampled synchronously by the bit clock.	I
I2S1_TX_BCLK	SAI_TX_BCLK	Transmit Bit Clock. The bit clock is an input when externally generated and an output when internally generated.	I/O
I2S1_TX_FS	SAI_TX_SYNC	Transmit Frame Sync. The frame sync is an input sampled synchronously by the bit clock when externally generated and an output generated synchronously by the bit clock when internally generated.	I/O
I2S1_TXD	SAI_TX_DATA	Transmit Data. The transmit data is generated synchronously by the bit clock and is tristated whenever not transmitting a word.	O

Table 37. FlexIO Signal Descriptions

Chip signal name	Module signal name	Description	I/O
FXIO0_Dn	FXIO_Dn (n=0...7)	Bidirectional FlexIO Shifter and Timer pin inputs/outputs	I/O

4.3.7 Human-Machine Interfaces (HMI)

Table 38. GPIO Signal Descriptions

Chip signal name	Module signal name	Description	I/O
PTA[31:0] ¹	PORTA31–PORTA0	General-purpose input/output	I/O
PTB[31:0] ¹	PORTB31–PORTB0	General-purpose input/output	I/O
PTC[31:0] ¹	PORTC31–PORTC0	General-purpose input/output	I/O
PTD[31:0] ¹	PORTD31–PORTD0	General-purpose input/output	I/O
PTE[31:0] ¹	PORTE31–PORTE0	General-purpose input/output	I/O

1. The available GPIO pins depends on the specific package. See the signal multiplexing section for which exact GPIO signals are available.

4.4 Pinouts

The following figure shows the pinout diagram for the devices supported by this document. Many signals may be multiplexed onto a single pin. To determine what signals can be used on which pin, see the previous "signal multiplexing and pin assignments" section.

Pinouts

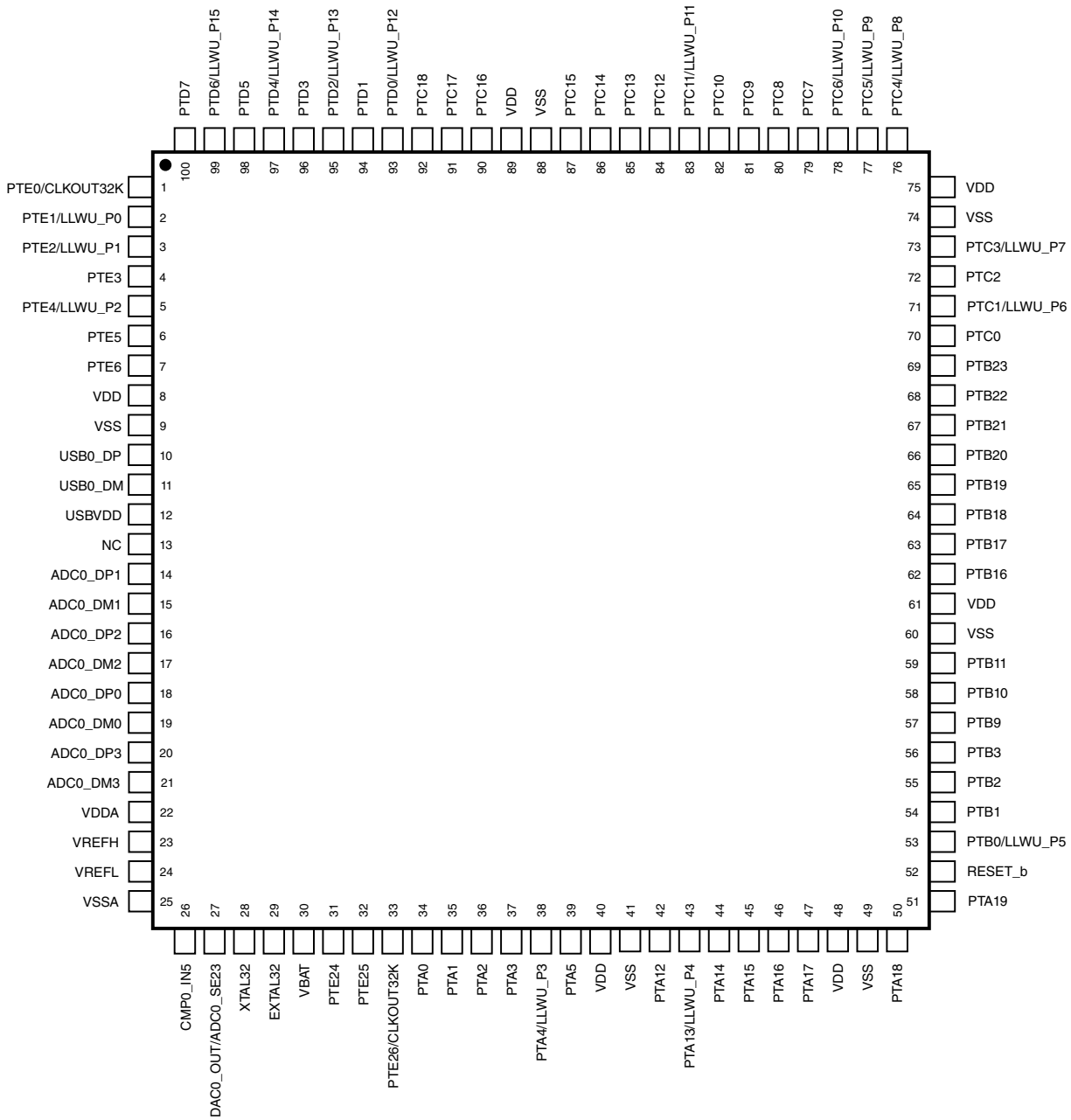

Figure 6. 100 LQFP Pinout Diagram

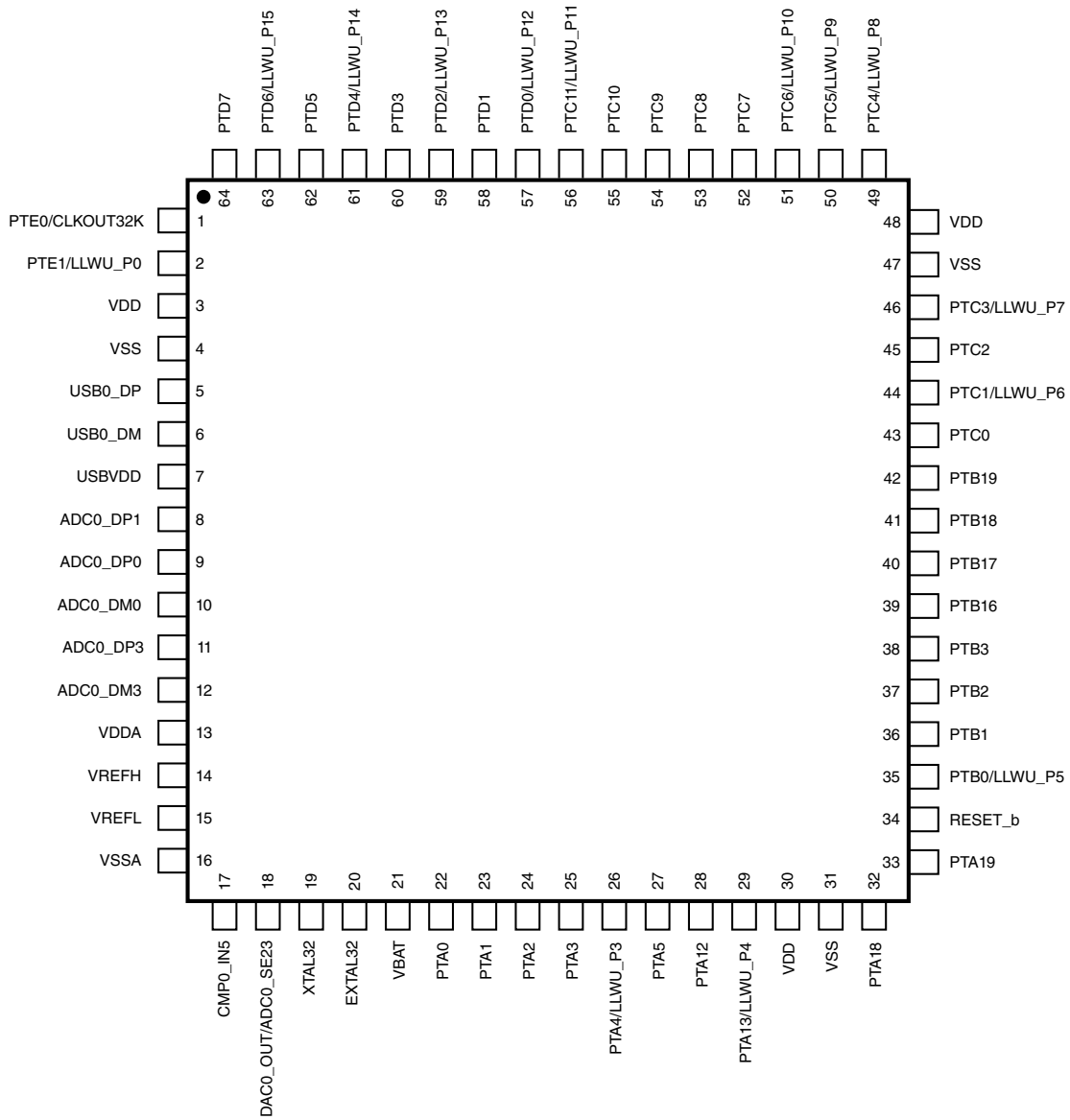

Figure 7. 64 LQFP Pinout Diagram

Pinouts

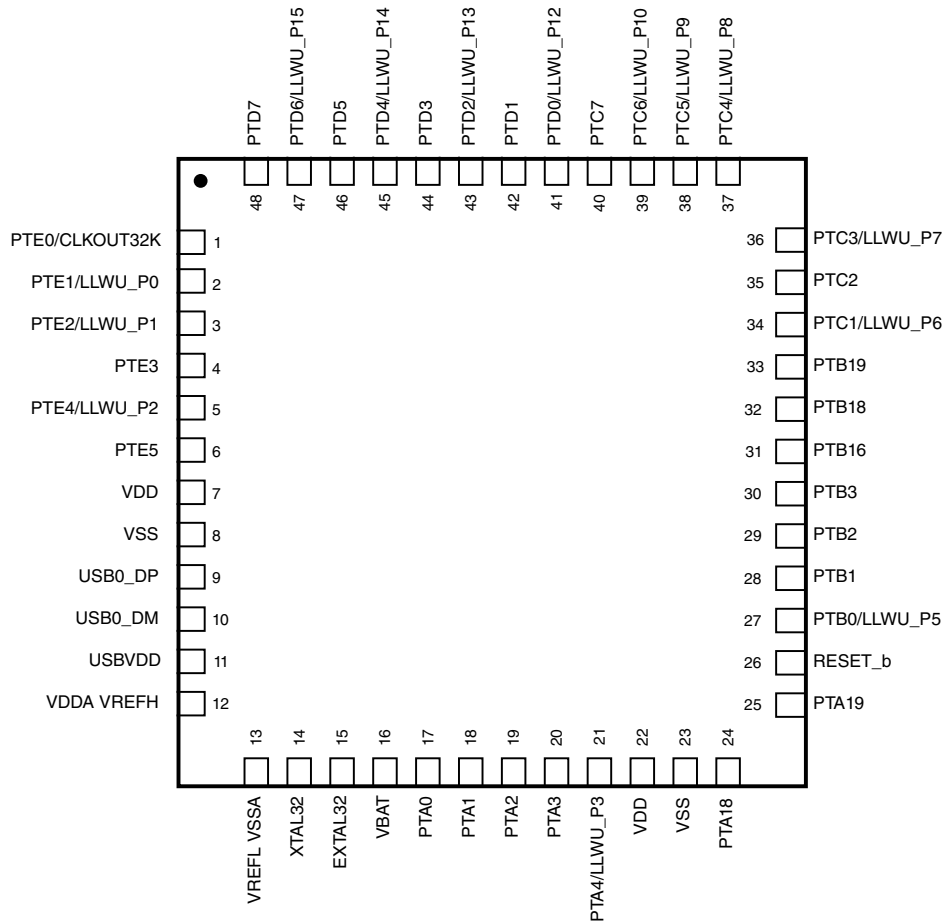
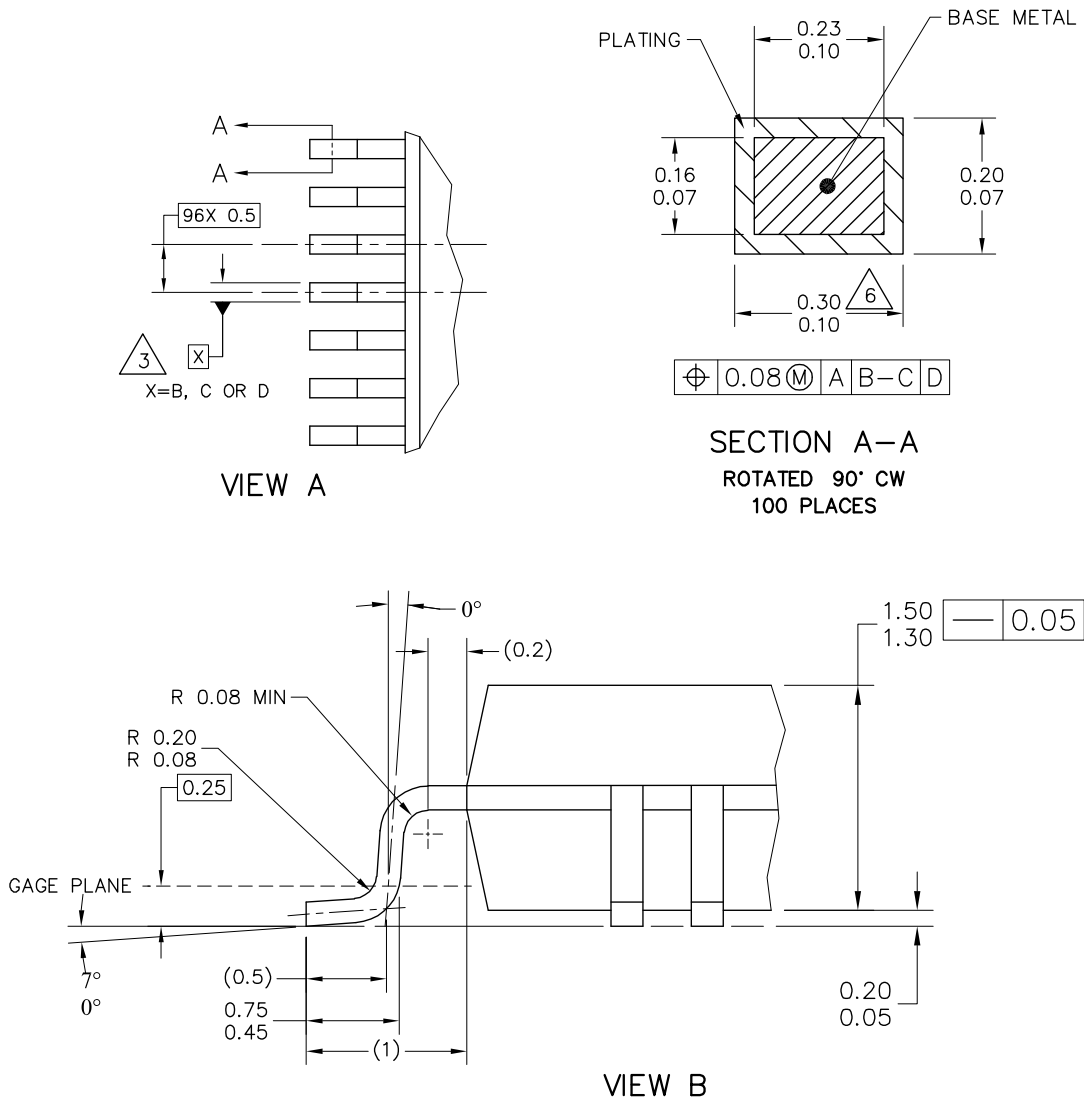

Figure 8. 48 QFN Pinout Diagram

4.5 Package dimensions

The following figures show the dimensions of the package options for the devices supported by this document.

Pinouts



NOTES:

1. ALL DIMENSIONS ARE IN MILLIMETERS.
2. INTERPRET DIMENSIONS AND TOLERANCES PER ASME Y14.5M-1994.
3. DATUMS B, C AND D TO BE DETERMINED AT DATUM PLANE H.
4. THE TOP PACKAGE BODY SIZE MAY BE SMALLER THAN THE BOTTOM PACKAGE SIZE BY A MAXIMUM OF 0.1 MM.
5. DIMENSIONS DO NOT INCLUDE MOLD PROTRUSIONS. THE MAXIMUM ALLOWABLE PROTRUSION IS 0.25 mm PER SIDE. THE DIMENSIONS ARE MAXIMUM BODY SIZE DIMENSIONS INCLUDING MOLD MISMATCH.
6. DIMENSION DOES NOT INCLUDE DAM BAR PROTRUSION. PROTRUSIONS SHALL NOT CAUSE THE LEAD WIDTH TO EXCEED 0.35. MINIMUM SPACE BETWEEN PROTRUSION AND AN ADJACENT LEAD SHALL BE 0.07 MM.
7. DIMENSIONS ARE DETERMINED AT THE SEATING PLANE, DATUM A.

Figure 10. 100-pin LQFP package dimensions 2

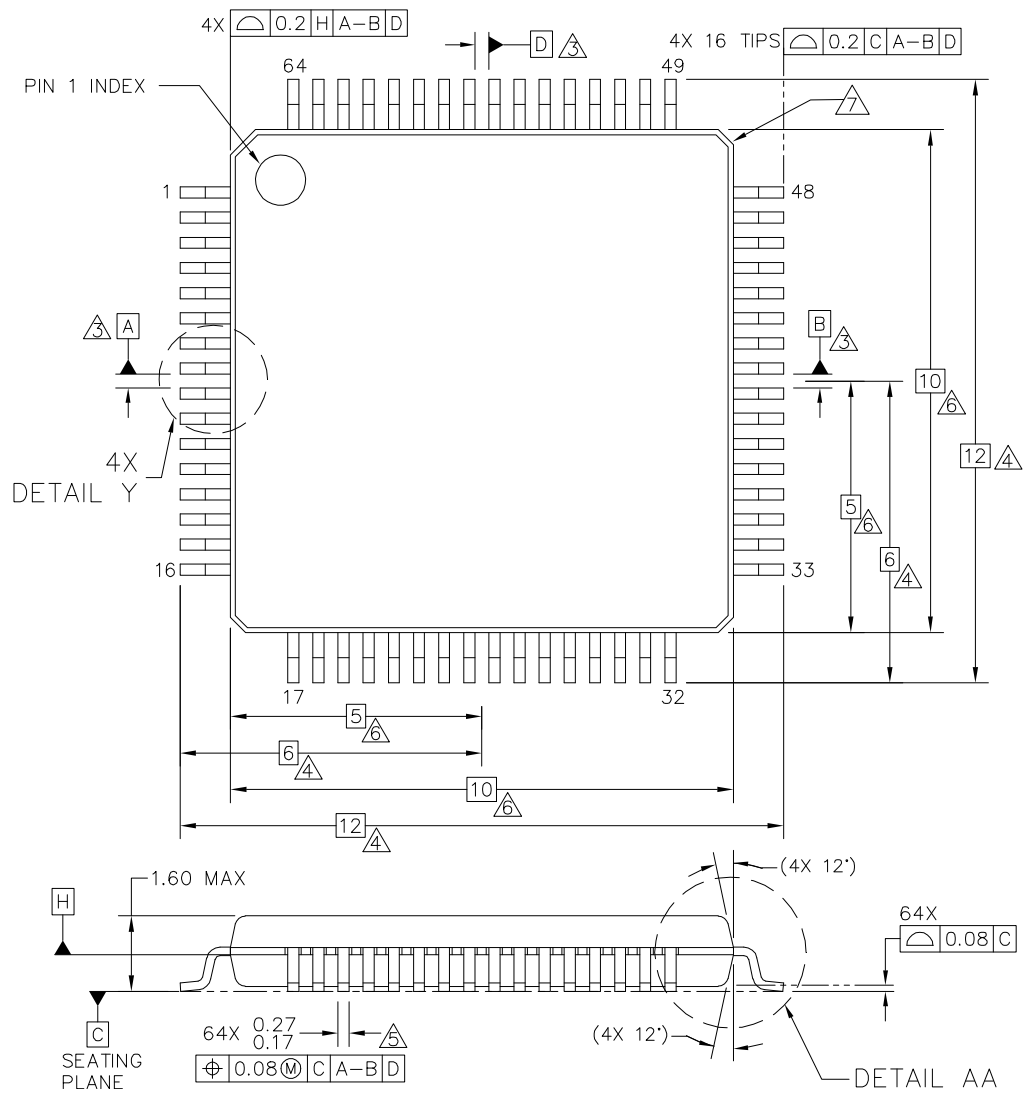

Figure 11. 64-pin LQFP package dimensions 1

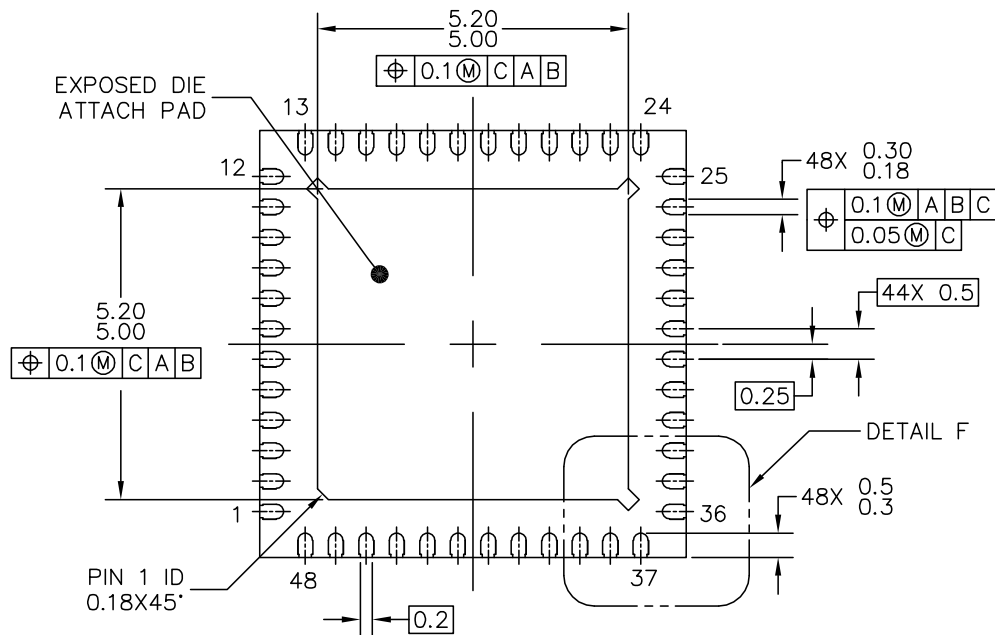
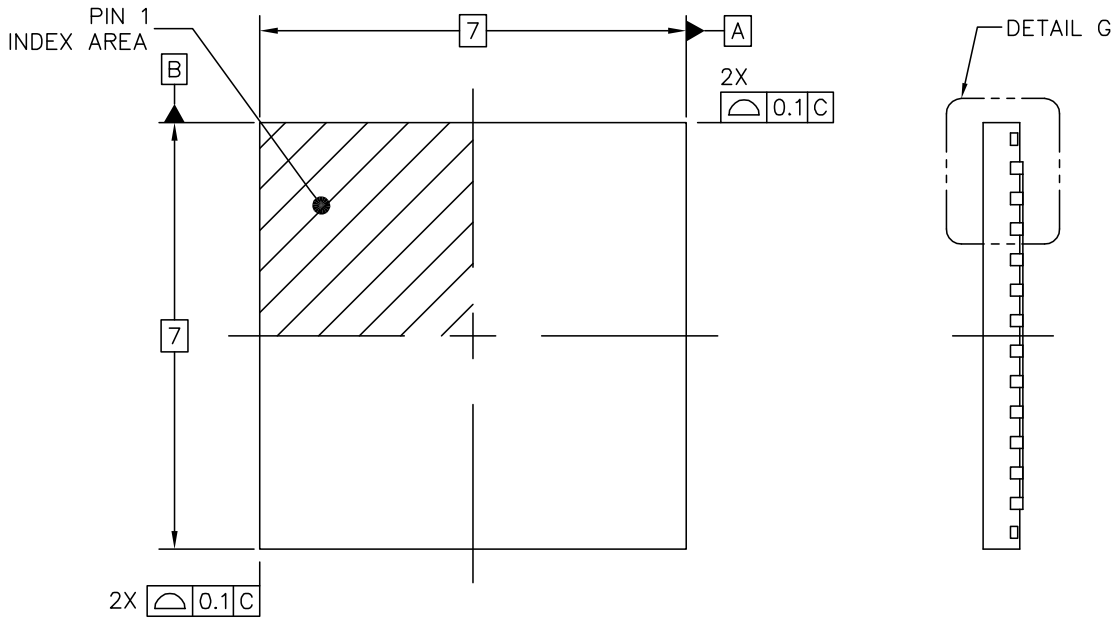
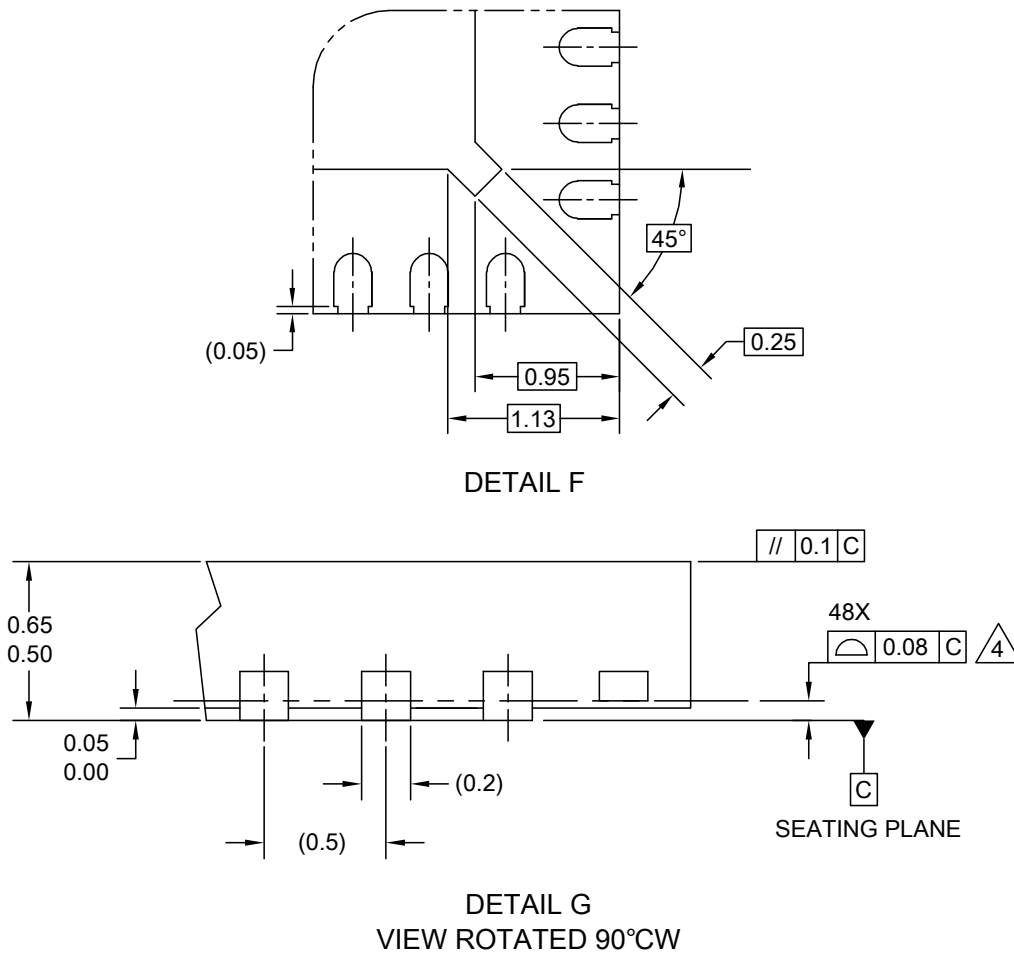

Figure 13. 48-pin QFN package dimension 1



NOTES:

1. ALL DIMENSIONS ARE IN MILLIMETERS.
2. DIMENSIONING AND TOLERANCING PER ASME Y14.5M-1994.
3. THIS IS A NON-JEDEC REGISTERED PACKAGE.
4. COPLANARITY APPLIES TO LEADS AND DIE ATTACH FLAG.
5. MIN. METAL GAP SHOULD BE 0.2 MM.

Figure 14. 48-pin QFN package dimension 2

5 Electrical characteristics

5.1 Terminology and guidelines

5.1.1 Definitions

Key terms are defined in the following table:

Term	Definition
Rating	<p>A minimum or maximum value of a technical characteristic that, if exceeded, may cause permanent chip failure:</p> <ul style="list-style-type: none"> • <i>Operating ratings</i> apply during operation of the chip. • <i>Handling ratings</i> apply when the chip is not powered. <p>NOTE: The likelihood of permanent chip failure increases rapidly as soon as a characteristic begins to exceed one of its operating ratings.</p>
Operating requirement	<p>A specified value or range of values for a technical characteristic that you must guarantee during operation to avoid incorrect operation and possibly decreasing the useful life of the chip</p>
Operating behavior	<p>A specified value or range of values for a technical characteristic that are guaranteed during operation if you meet the operating requirements and any other specified conditions</p>
Typical value	<p>A specified value for a technical characteristic that:</p> <ul style="list-style-type: none"> • Lies within the range of values specified by the operating behavior • Is representative of that characteristic during operation when you meet the typical-value conditions or other specified conditions <p>NOTE: Typical values are provided as design guidelines and are neither tested nor guaranteed.</p>

5.1.2 Examples

Operating rating:

Symbol	Description	Min.	Max.	Unit
V _{DD}	1.0 V core supply voltage	-0.3	1.2	V

Operating requirement:

Symbol	Description	Min.	Max.	Unit
V _{DD}	1.0 V core supply voltage	0.9	1.1	V

Operating behavior that includes a typical value:

Symbol	Description	Min.	Typ.	Max.	Unit
I _{WP}	Digital I/O weak pullup/pulldown current	10	70	130	μA

5.1.3 Typical-value conditions

Typical values assume you meet the following conditions (or other conditions as specified):

Symbol	Description	Value	Unit
T _A	Ambient temperature	25	°C
V _{DD}	Supply voltage	3.3	V

5.1.4 Relationship between ratings and operating requirements

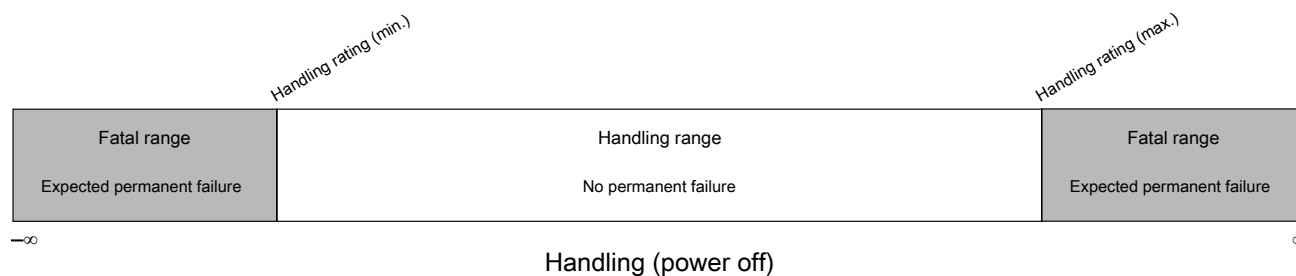
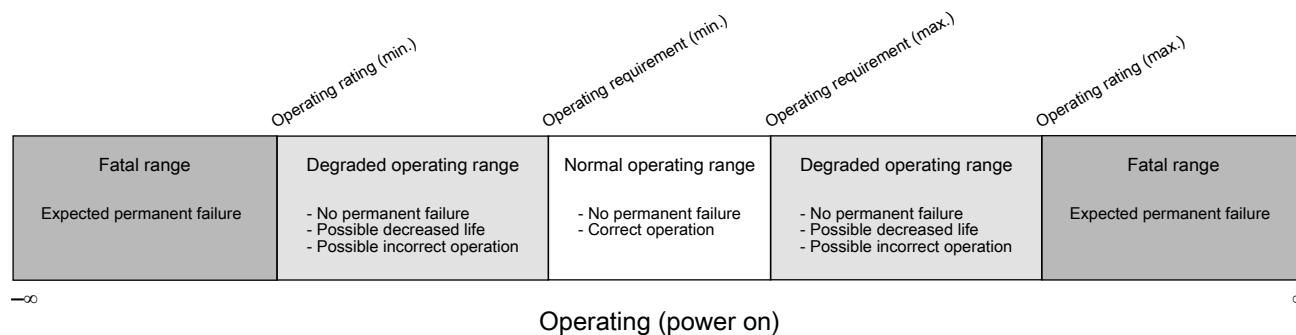

5.1.5 Guidelines for ratings and operating requirements

Follow these guidelines for ratings and operating requirements:

- Never exceed any of the chip's ratings.
- During normal operation, don't exceed any of the chip's operating requirements.
- If you must exceed an operating requirement at times other than during normal operation (for example, during power sequencing), limit the duration as much as possible.

5.2 Ratings

5.2.1 Thermal handling ratings

Symbol	Description	Min.	Max.	Unit	Notes
T _{STG}	Storage temperature	-55	150	°C	1
T _{SDR}	Solder temperature, lead-free	—	260	°C	2

1. Determined according to JEDEC Standard JESD22-A103, *High Temperature Storage Life*.
2. Determined according to IPC/JEDEC Standard J-STD-020, *Moisture/Reflow Sensitivity Classification for Nonhermetic Solid State Surface Mount Devices*.

5.2.2 Moisture handling ratings

Symbol	Description	Min.	Max.	Unit	Notes
MSL	Moisture sensitivity level	—	3	—	1

1. Determined according to IPC/JEDEC Standard J-STD-020, *Moisture/Reflow Sensitivity Classification for Nonhermetic Solid State Surface Mount Devices*.

5.2.3 ESD handling ratings

Symbol	Description	Min.	Max.	Unit	Notes
V _{HBM}	Electrostatic discharge voltage, human body model	-2000	+2000	V	1
V _{CDM}	Electrostatic discharge voltage, charged-device model	-500	+500	V	2
I _{LAT}	Latch-up current at ambient temperature of 105°C	-100	+100	mA	3

1. Determined according to JEDEC Standard JESD22-A114, *Electrostatic Discharge (ESD) Sensitivity Testing Human Body Model (HBM)*.
2. Determined according to JEDEC Standard JESD22-C101, *Field-Induced Charged-Device Model Test Method for Electrostatic-Discharge-Withstand Thresholds of Microelectronic Components*.
3. Determined according to JEDEC Standard JESD78, *IC Latch-Up Test*.

5.2.4 Voltage and current operating ratings

Table 39. Voltage and current operating ratings

Symbol	Description	Min.	Max.	Unit
V _{DD}	Digital supply voltage	-0.3	3.8	V
I _{DD}	Digital supply current	—	120	mA
V _{IO}	IO pin input voltage	-0.3	V _{DD} + 0.3	V
I _D	Instantaneous maximum current single pin limit (applies to all port pins)	-25	25	mA
V _{DDA}	Analog supply voltage	V _{DD} - 0.3	V _{DD} + 0.3	V
V _{USB_DP}	USB_DP input voltage	-0.3	3.63	V
V _{USB_DM}	USB_DM input voltage	-0.3	3.63	V
V _{BAT}	RTC battery supply voltage	-0.3	3.8	V

5.3 General

5.3.1 AC electrical characteristics

Unless otherwise specified, propagation delays are measured from the 50% to the 50% point, and rise and fall times are measured at the 20% and 80% points, as shown in the following figure.

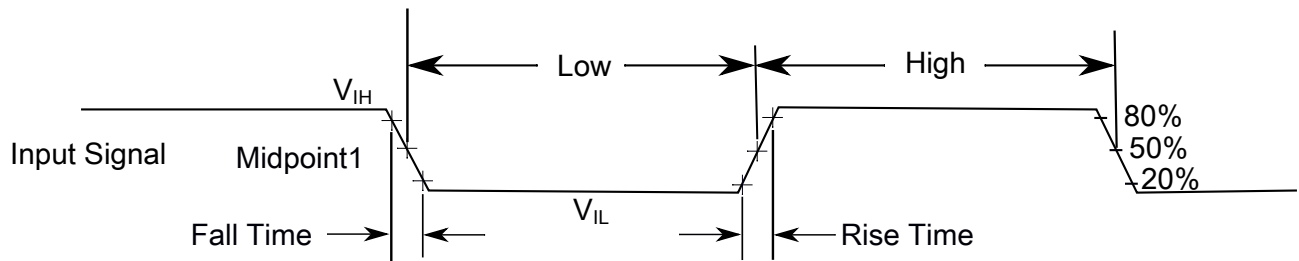

The midpoint is $V_{IL} + (V_{IH} - V_{IL}) / 2$

Figure 15. Input signal measurement reference

All digital I/O switching characteristics, unless otherwise specified, assume that the output pins have the following characteristics.

- $C_L=30$ pF loads
- Slew rate disabled
- Normal drive strength

5.3.2 Nonswitching electrical specifications

5.3.2.1 Voltage and current operating requirements

Table 40. Voltage and current operating requirements

Symbol	Description	Min.	Max.	Unit	Notes
V_{DD}	Supply voltage	1.71	3.6	V	
V_{DDA}	Analog supply voltage	1.71	3.6	V	
$V_{DD} - V_{DDA}$	V_{DD} -to- V_{DDA} differential voltage	-0.1	0.1	V	
$V_{SS} - V_{SSA}$	V_{SS} -to- V_{SSA} differential voltage	-0.1	0.1	V	
V_{BAT}	RTC battery supply voltage	1.71	3.6	V	
$USBV_{DD}$	USB Transceiver supply voltage	3.0	3.6	V	1
V_{IH}	Input high voltage <ul style="list-style-type: none"> • $2.7\text{ V} \leq V_{DD} \leq 3.6\text{ V}$ • $1.7\text{ V} \leq V_{DD} \leq 2.7\text{ V}$ 	$0.7 \times V_{DD}$ $0.75 \times V_{DD}$	— —	V V	

Table continues on the next page...

Electrical characteristics

Table 40. Voltage and current operating requirements (continued)

Symbol	Description	Min.	Max.	Unit	Notes
V _{IL}	Input low voltage <ul style="list-style-type: none"> • $2.7\text{ V} \leq V_{DD} \leq 3.6\text{ V}$ • $1.7\text{ V} \leq V_{DD} \leq 2.7\text{ V}$ 	—	$0.35 \times V_{DD}$	V	
		—	$0.3 \times V_{DD}$	V	
V _{HYS}	Input hysteresis	$0.06 \times V_{DD}$	—	V	
I _{ICIO}	Analog and I/O pin DC injection current — single pin <ul style="list-style-type: none"> • $V_{IN} < V_{SS}-0.3\text{V}$ (Negative current injection) 	-3	—	mA	2
I _{ICcont}	Contiguous pin DC injection current —regional limit, includes sum of negative injection currents or sum of positive injection currents of 16 contiguous pins <ul style="list-style-type: none"> • Negative current injection 	-25	—	mA	
V _{ODPU}	Open drain pullup voltage level	V _{DD}	V _{DD}	V	3
V _{RAM}	V _{DD} voltage required to retain RAM	1.2	—	V	
V _{RFVBAT}	V _{BAT} voltage required to retain the VBAT register file	V _{POR_VBAT}	—	V	

1. USB nominal operating voltage is 3.3 V.
2. All analog and I/O pins are internally clamped to V_{SS} through ESD protection diodes. If V_{IN} is less than V_{IO_MIN} or greater than V_{IO_MAX}, a current limiting resistor is required. The negative DC injection current limiting resistor is calculated as $R=(V_{IO_MIN}-V_{IN})/|I_{ICIO}|$.
3. Open drain outputs must be pulled to V_{DD}.

5.3.2.2 HVD, LVD and POR operating requirements

Table 41. V_{DD} supply HVD, LVD and POR operating requirements

Symbol	Description	Min.	Typ.	Max.	Unit	Notes
V _{HVDH}	High Voltage Detect (High Trip Point)	—	3.72	—	V	
V _{HVDL}	High Voltage Detect (Low Trip Point)	—	3.46	—	V	
V _{POR}	Falling V _{DD} POR detect voltage	0.8	1.1	1.5	V	
V _{LVDH}	Falling low-voltage detect threshold — high range (LVDV=01)	2.48	2.56	2.64	V	
V _{LVW1H} V _{LVW2H} V _{LVW3H} V _{LVW4H}	Low-voltage warning thresholds — high range <ul style="list-style-type: none"> • Level 1 falling (LVWV=00) • Level 2 falling (LVWV=01) • Level 3 falling (LVWV=10) • Level 4 falling (LVWV=11) 	2.62	2.70	2.78	V	1
		2.72	2.80	2.88	V	
		2.82	2.90	2.98	V	
		2.92	3.00	3.08	V	
V _{HYSH}	Low-voltage inhibit reset/recover hysteresis — high range	—	80	—	mV	
V _{LVDL}	Falling low-voltage detect threshold — low range (LVDV=00)	1.54	1.60	1.66	V	
	Low-voltage warning thresholds — low range					1

Table continues on the next page...

Table 41. V_{DD} supply HVD, LVD and POR operating requirements (continued)

Symbol	Description	Min.	Typ.	Max.	Unit	Notes
V _{LVW1L}	• Level 1 falling (LVWV=00)	1.74	1.80	1.86	V	
V _{LVW2L}	• Level 2 falling (LVWV=01)	1.84	1.90	1.96	V	
V _{LVW3L}	• Level 3 falling (LVWV=10)	1.94	2.00	2.06	V	
V _{LVW4L}	• Level 4 falling (LVWV=11)	2.04	2.10	2.16	V	
V _{HYSL}	Low-voltage inhibit reset/recover hysteresis — low range	—	60	—	mV	
V _{BG}	Bandgap voltage reference	0.97	1.00	1.03	V	
t _{LPO}	Internal low power oscillator period — factory trimmed	900	1000	1100	μs	

1. Rising threshold is the sum of falling threshold and hysteresis voltage

Table 42. VBAT power operating requirements

Symbol	Description	Min.	Typ.	Max.	Unit	Notes
V _{POR_VBAT}	Falling VBAT supply POR detect voltage	0.8	1.1	1.5	V	

5.3.2.3 Voltage and current operating behaviors

Table 43. Voltage and current operating behaviors

Symbol	Description	Min.	Typ.	Max.	Unit	Notes
V _{OH}	Output high voltage — Normal drive pad except RESET_B					
	2.7 V ≤ V _{DD} ≤ 3.6 V, I _{OH} = -5 mA	V _{DD} - 0.5	—	—	V	1
V _{OH}	Output high voltage — High drive pad except RESET_B					
	2.7 V ≤ V _{DD} ≤ 3.6 V, I _{OH} = -20 mA	V _{DD} - 0.5	—	—	V	1
V _{OH}	Output high voltage — High drive pad except RESET_B					
	1.71 V ≤ V _{DD} ≤ 2.7 V, I _{OH} = -10 mA	V _{DD} - 0.5	—	—	V	
I _{OHT}	Output high current total for all ports	—	—	100	mA	
V _{OL}	Output low voltage — Normal drive pad except RESET_B					
	2.7 V ≤ V _{DD} ≤ 3.6 V, I _{OL} = 5 mA	—	—	0.5	V	1
V _{OL}	Output low voltage — Normal drive pad except RESET_B					
	1.71 V ≤ V _{DD} ≤ 2.7 V, I _{OL} = 2.5 mA	—	—	0.5	V	
V _{OL}	Output low voltage — High drive pad except RESET_B					
	2.7 V ≤ V _{DD} ≤ 3.6 V, I _{OL} = 20 mA	—	—	0.5	V	1
V _{OL}	Output low voltage — High drive pad except RESET_B					
	1.71 V ≤ V _{DD} ≤ 2.7 V, I _{OL} = 10 mA	—	—	0.5	V	
V _{OL}	Output low voltage — RESET_B					
V _{OL}	2.7 V ≤ V _{DD} ≤ 3.6 V, I _{OL} = 3 mA	—	—	0.5	V	

Table continues on the next page...

Table 43. Voltage and current operating behaviors (continued)

Symbol	Description	Min.	Typ.	Max.	Unit	Notes
	$1.71\text{ V} \leq V_{DD} \leq 2.7\text{ V}$, $I_{OL} = 1.5\text{ mA}$	—	—	0.5	V	
I_{OLT}	Output low current total for all ports	—	—	100	mA	
I_{IN}	Input leakage current (per pin) for full temperature range					
	All pins other than high drive port pins	—	0.002	0.5	μA	1, 2
	High drive port pins	—	0.004	0.5	μA	
I_{IN}	Input leakage current (total all pins) for full temperature range	—	—	1.0	μA	2
R_{PU}	Internal pullup resistors	20	—	50	$\text{k}\Omega$	3
R_{PD}	Internal pulldown resistors	20	—	50	$\text{k}\Omega$	4

1. PTB0, PTB1, PTD4, PTD5, PTD6, PTD7, PTC3, and PTC4 I/O have both high drive and normal drive capability selected by the associated $PTx_PCRn[DSE]$ control bit. All other GPIOs are normal drive only.
2. Measured at $V_{DD}=3.6\text{V}$
3. Measured at V_{DD} supply voltage = V_{DD} min and $V_{input} = V_{SS}$
4. Measured at V_{DD} supply voltage = V_{DD} min and $V_{input} = V_{DD}$

5.3.2.4 Power mode transition operating behaviors

All specifications except t_{POR} and $VLLSx \rightarrow \text{RUN}$ recovery times in the following table assume this clock configuration:

- CPU and system clocks = 80 MHz
- Bus clock = 40 MHz
- Flash clock = 20 MHz
- MCG mode: FEI

Table 44. Power mode transition operating behaviors

Symbol	Description	Min.	Typ.	Max.	Unit	Notes
t_{POR}	After a POR event, amount of time from the point V_{DD} reaches 1.71 V to execution of the first instruction across the operating temperature range of the chip.	—	—	300	μs	1
	• $VLLS0 \rightarrow \text{RUN}$	—	—	140	μs	
	• $VLLS1 \rightarrow \text{RUN}$	—	—	140	μs	
	• $VLLS2 \rightarrow \text{RUN}$	—	—	80	μs	
	• $VLLS3 \rightarrow \text{RUN}$	—	—	80	μs	

Table continues on the next page...

Table 44. Power mode transition operating behaviors (continued)

Symbol	Description	Min.	Typ.	Max.	Unit	Notes
	• LLS2 → RUN	—	—	6	μs	
	• LLS3 → RUN	—	—	6	μs	
	• VLPS → RUN	—	—	5.7	μs	
	• STOP → RUN	—	—	5.7	μs	

1. Normal boot (FTFA_FOPT[LPBOOT]=1)

5.3.2.5 Power consumption operating behaviors

The maximum values stated in the following table represent the characterized results equivalent to the mean plus three times the standard deviation (mean + 3 sigma).

NOTE

The while(1) test is executed with flash cache enabled.

Table 45. Power consumption operating behaviors

Symbol	Description	Min.	Typ.	Max.	Unit	Notes
I _{DDA}	Analog supply current	—	—	See note	mA	1
I _{DD_HSRUN}	High Speed Run mode current - all peripheral clocks disabled, CoreMark benchmark code executing from flash @ 1.8V	—	24.17	26.215	mA	2, 3, 4
		—	24.20	26.292	mA	
I _{DD_HSRUN}	High Speed Run mode current - all peripheral clocks disabled, code executing from flash @ 1.8V	—	20.97	23.015	mA	2
		—	20.97	23.062	mA	
I _{DD_HSRUN}	High Speed Run mode current — all peripheral clocks enabled, code executing from flash @ 1.8V	—	27.77	30.028	mA	5
		—	27.79	30.083	mA	
I _{DD_RUN}	Run mode current in Compute operation — CoreMark benchmark code executing from flash @ 1.8V	—	15.58	16.790	mA	3, 4, 6
		—	16.19	17.457	mA	

Table continues on the next page...

Table 45. Power consumption operating behaviors (continued)

Symbol	Description	Min.	Typ.	Max.	Unit	Notes
I _{DD_RUN}	Run mode current in Compute operation — code executing from flash @ 1.8V @ 3.0V	— —	13.38 13.42	14.590 14.687	mA mA	6
I _{DD_RUN}	Run mode current — all peripheral clocks disabled, code executing from flash @ 1.8V @ 3.0V • @ 25°C • @ -40°C • @ 70°C • @ 85°C • @ 105°C	— — — — —	13.81 13.87 13.72 14.03 14.12 14.31	15.087 15.158 15.050 15.267 15.347 15.529	mA mA mA mA mA mA	7
I _{DD_RUN}	Run mode current — all peripheral clocks enabled, code executing from flash @ 1.8V @ 3.0V • @ 25°C • @ -40°C • @ 70°C • @ 85°C • @ 105°C	— — — — —	18.00 18.08 17.88 18.27 18.35 18.55	20.042 20.145 20.022 20.229 20.321 20.544	mA mA mA mA mA mA	8
I _{DD_RUN}	Run mode current — Compute operation, code executing from flash @ 1.8V @ 3.0V • @ 25°C • @ -40°C • @ 70°C • @ 85°C • @ 105°C	— — — — —	12.68 12.62 12.53 12.76 12.84 13.02	13.763 13.714 13.652 13.827 13.895 14.078	mA mA mA mA mA mA	9
I _{DD_WAIT}	Wait mode high frequency current at 3.0 V — all peripheral clocks disabled	—	6.56	7.022	mA	7
I _{DD_WAIT}	Wait mode reduced frequency current at 3.0 V — all peripheral clocks disabled	—	3.80	4.118	mA	10

Table continues on the next page...

Table 45. Power consumption operating behaviors (continued)

Symbol	Description	Min.	Typ.	Max.	Unit	Notes
I _{DD_VLPR}	Very-low-power run mode current in Compute operation — CoreMark benchmark code executing from flash @ 1.8V @ 3.0V	—	967.09	1031.341	μA	3, 4, 11
		—	973.06	1040.294	μA	
I _{DD_VLPR}	Very-low-power run mode current in Compute operation, code executing from flash @ 1.8V @ 3.0V	—	449.10	513.351	μA	11
		—	462.61	529.844	μA	
I _{DD_VLPR}	Very-low-power run mode current at 3.0 V — all peripheral clocks disabled	—	520.34	592.022	μA	12
I _{DD_VLPR}	Very-low-power run mode current at 3.0 V — all peripheral clocks enabled	—	845.46	1005.706	μA	13
I _{DD_VLPW}	Very-low-power wait mode current at 3.0 V — all peripheral clocks disabled	—	240.81	269.275	μA	14
I _{DD_STOP}	Stop mode current at 3.0 V @ 25°C @ -40°C @ 70°C @ 85°C @ 105°C	—	269.63	292.223	μA	
		—	253.73	280.001	μA	
		—	309.98	346.335	μA	
		—	347.88	401.693	μA	
		—	450.05	565.013	μA	
I _{DD_VLPS}	Very-low-power stop mode current at 3.0 V @ 25°C @ -40°C @ 70°C @ 85°C @ 105°C	—	3.48	6.005	μA	
		—	2.47	3.740	μA	
		—	15.20	30.384	μA	
		—	28.62	52.396	μA	
		—	65.48	115.129	μA	
I _{DD_LLS3}	Low leakage stop mode 3 current at 3.0 V @ 25°C @ -40°C @ 70°C @ 85°C @ 105°C	—	2.78	3.778	μA	
		—	2.14	2.881	μA	
		—	7.72	12.481	μA	
		—	13.30	21.607	μA	
		—	29.50	47.202	μA	
I _{DD_LLS2}	Low leakage stop mode 2 current at 3.0 V @ 25°C @ -40°C @ 70°C @ 85°C @ 105°C	—	2.56	3.293	μA	
		—	2.10	2.802	μA	
		—	6.14	8.758	μA	
		—	10.34	15.242	μA	
		—	22.68	33.393	μA	
I _{DD_VLLS3}	Very low-leakage stop mode 3 current at 3.0 V @ 25°C	—	2.01	2.769	μA	

Table continues on the next page...

Table 45. Power consumption operating behaviors (continued)

Symbol	Description	Min.	Typ.	Max.	Unit	Notes
	@ -40°C @ 70°C @ 85°C @ 105°C	— — — —	1.55 5.81 10.06 22.30	2.485 9.658 16.695 35.783	μA μA μA μA	
I _{DD_VLLS2}	Very low-leakage stop mode 2 current at 3.0 V @ 25°C @ -40°C @ 70°C @ 85°C @ 105°C	— — — — —	1.76 1.51 3.73 6.12 13.22	2.298 1.963 5.221 8.624 18.408	μA μA μA μA μA	
I _{DD_VLLS1}	Very low-leakage stop mode 1 current at 3.0 V @ 25°C @ -40°C @ 70°C @ 85°C @ 105°C	— — — — —	0.64 0.55 1.88 3.52 8.62	0.835 0.795 2.427 4.640 11.273	μA μA μA μA μA	
I _{DD_VLLS0}	Very low-leakage stop mode 0 current at 3.0 V with POR detect circuit enabled @ 25°C @ -40°C @ 70°C @ 85°C @ 105°C	— — — — —	0.36 0.29 1.58 3.19 8.20	0.525 0.513 2.108 4.289 10.838	μA μA μA μA μA	
I _{DD_VLLS0}	Very low-leakage stop mode 0 current at 3.0 V with POR detect circuit disabled @ 25°C @ -40°C @ 70°C @ 85°C @ 105°C	— — — — —	0.093 0.016 1.30 2.91 7.92	0.249 0.145 1.821 3.994 10.501	μA μA μA μA μA	
I _{DD_VBAT}	Average current with RTC and 32kHz disabled at 3.0 V @ 25°C @ -40°C @ 70°C @ 85°C @ 105°C	— — — — —	0.21 0.14 1.15 2.44 6.49	0.245 0.163 1.498 3.596 9.557	μA μA μA μA μA	V _{DD} is off.
I _{DD_VBAT}	Average current when CPU is not accessing RTC registers at 3.0 V • @ 25°C	—	0.76	0.899	μA	V _{DD} is off.

Table continues on the next page...

Table 45. Power consumption operating behaviors (continued)

Symbol	Description	Min.	Typ.	Max.	Unit	Notes
	• @ -40°C	—	0.63	0.745	μA	
	• @ 70°C	—	1.80	2.346	μA	
	• @ 85°C	—	3.11	4.575	μA	
	• @ 105°C	—	7.24	10.653	μA	

- The analog supply current is the sum of the active or disabled current for each of the analog modules on the device. See each module's specification for its supply current.
- 120MHz core and system clock, 60MHz bus clock, and 24MHz flash clock. MCG configured for PEE mode. All peripheral clocks disabled.
- Cache on and prefetch on, low compiler optimization.
- Coremark benchmark compiled using IAR 7.2 with optimization level high.
- 120MHz core and system clock, 60MHz bus clock, and 24MHz flash clock. MCG configured for PEE mode. All peripheral clocks enabled.
- 80 MHz core and system clock, 40 MHz bus clock, and 26.67 MHz flash clock. MCG configured for PEE mode. Compute operation.
- 80MHz core and system clock, 40MHz bus clock, and 26.67MHz flash clock. MCG configured for FEI mode. All peripheral clocks disabled.
- 80MHz core and system clock, 40MHz bus clock, and 26.67MHz flash clock. MCG configured for FEI mode. All peripheral clocks enabled.
- 80MHz core and system clock, 40MHz bus clock, and 26.67MHz flash clock. MCG configured for FEI mode. Compute operation.
- 25MHz core and system clock, 25MHz bus clock, and 25MHz flash clock. MCG configured for FEI mode.
- 4 MHz core, system, and bus clock and 1MHz flash clock. MCG configured for BLPE mode. Compute operation. Code executing from flash.
- 4 MHz core, system, and bus clock and 1MHz flash clock. MCG configured for BLPE mode. All peripheral clocks disabled. Code executing from flash.
- 4 MHz core, system, and bus clock and 1MHz flash clock. MCG configured for BLPE mode. All peripheral clocks enabled but peripherals are not in active operation. Code executing from flash.
- 4 MHz core, system, and bus clock and 1MHz flash clock. MCG configured for BLPE mode. All peripheral clocks disabled.

5.3.2.5.1 Diagram: Typical IDD_RUN operating behavior

The following data was measured under these conditions:

- MCG in FBE mode for 50 MHz and lower frequencies. MCG in FEE mode at frequencies between 50 MHz and 100MHz.
- No GPIOs toggled
- Code execution from flash with cache enabled
- For the ALLOFF curve, all peripheral clocks are disabled except FTFA

Electrical characteristics

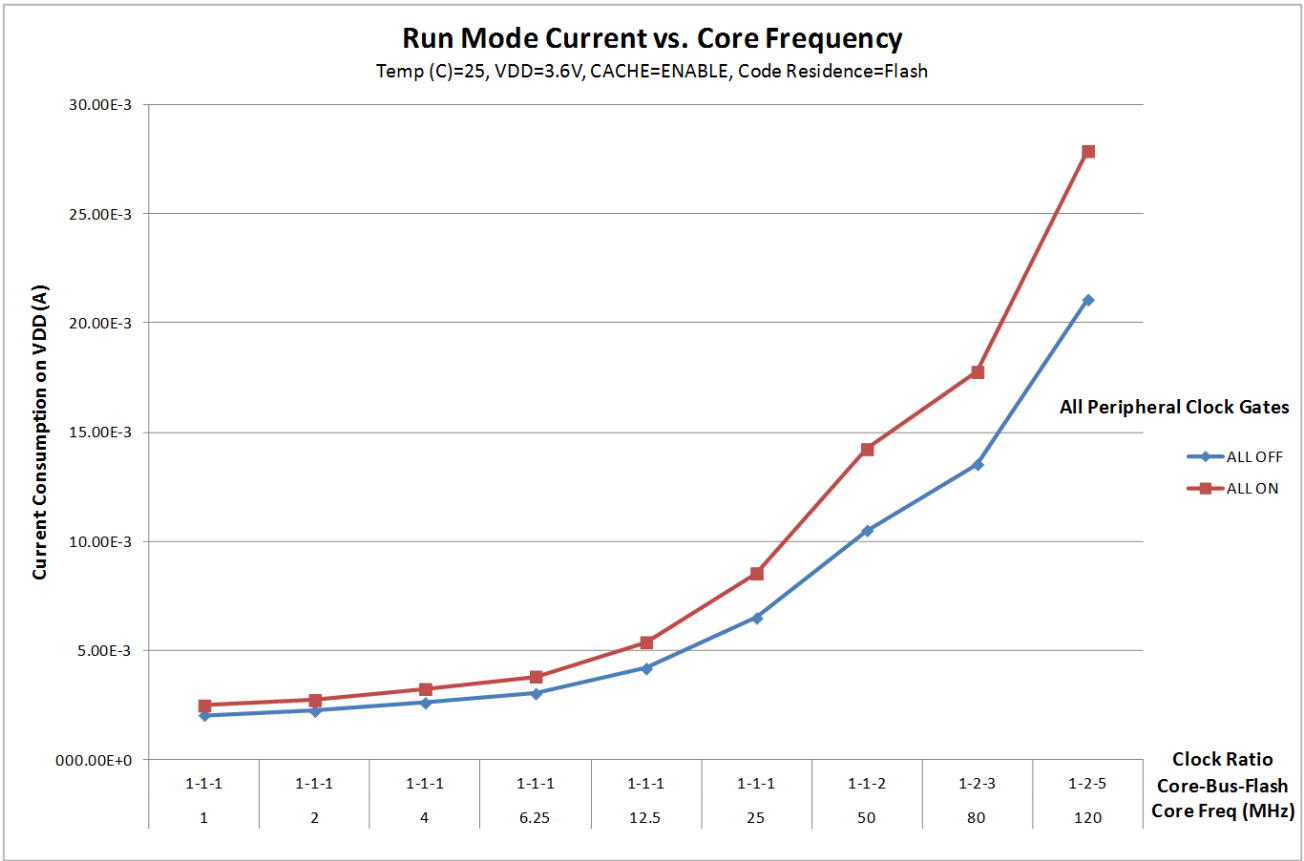

Figure 16. Run mode supply current vs. core frequency

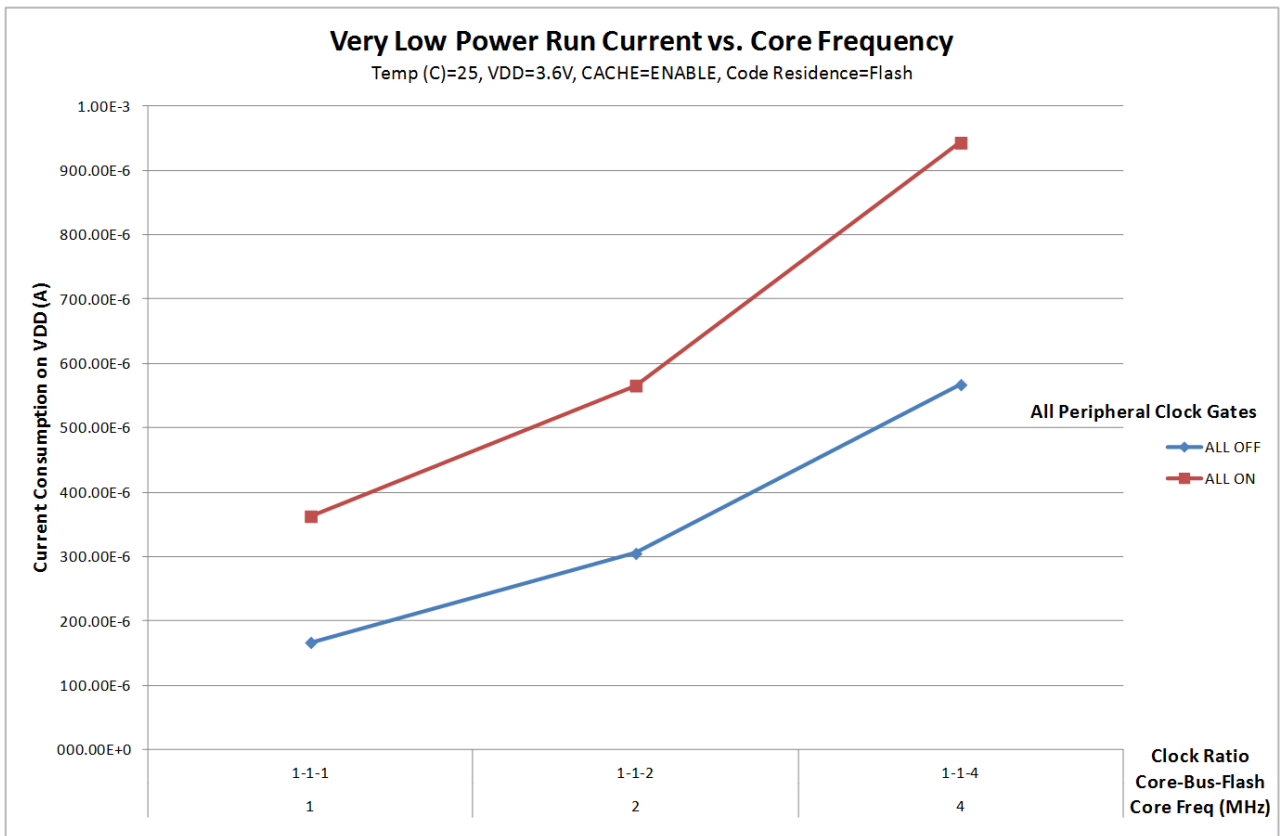

Figure 17. VLPR mode supply current vs. core frequency

5.3.2.6 EMC performance

Electromagnetic compatibility (EMC) performance is highly dependent on the environment in which the MCU resides. Board design and layout, circuit topology choices, location and characteristics of external components, and MCU software operation play a significant role in the EMC performance. The system designer can consult the following applications notes, available on <http://www.nxp.com> for advice and guidance specifically targeted at optimizing EMC performance.

- AN2321: Designing for Board Level Electromagnetic Compatibility
- AN1050: Designing for Electromagnetic Compatibility (EMC) with HCMOS Microcontrollers
- AN1263: Designing for Electromagnetic Compatibility with Single-Chip Microcontrollers

Electrical characteristics

- AN2764: Improving the Transient Immunity Performance of Microcontroller-Based Applications
- AN1259: System Design and Layout Techniques for Noise Reduction in MCU-Based Systems

5.3.2.6.1 EMC radiated emissions operating behaviors

Table 46. EMC radiated emissions operating behaviors for 64 LQFP package

Parameter	Conditions	Clocks	Frequency range	Level (Typ.)	Unit	Notes
V _{EME}	Device configuration, test conditions and EM testing per standard IEC 61967-2. Supply voltages: • VDD = 3.3 V Temp = 25°C	FSYS = 120 MHz FBUS = 60 MHz External crystal = 8 MHz	150 kHz–50 MHz	14	dBuV	1, 2
			50 MHz–150 MHz	23		
			150 MHz–500 MHz	23		
			500 MHz–1000 MHz	9		
		IEC level	L		3	

1. Measurements were made per IEC 61967-2 while the device was running typical application code.
2. The reported emission level is the value of the maximum measured emission, rounded up to the next whole number, from among the measured orientations in each frequency range.
3. IEC Level Maximums: M ≤ 18dBmV, L ≤ 24dBmV, K ≤ 30dBmV, I ≤ 36dBmV, H ≤ 42dBmV .

5.3.2.6.2 Designing with radiated emissions in mind

To find application notes that provide guidance on designing your system to minimize interference from radiated emissions:

1. Go to www.nxp.com.
2. Perform a keyword search for “EMC design.”

5.3.2.7 Capacitance attributes

Table 47. Capacitance attributes

Symbol	Description	Min.	Max.	Unit
C _{IN_A}	Input capacitance: analog pins	—	7	pF
C _{IN_D}	Input capacitance: digital pins	—	7	pF

5.3.3 Switching specifications

5.3.3.1 Device clock specifications

Table 48. Device clock specifications

Symbol	Description	Min.	Max.	Unit
High Speed run mode				
f_{SYS}	System and core clock	—	120	MHz
f_{BUS}	Bus clock	—	60	MHz
Normal run mode				
f_{SYS}	System and core clock	—	80	MHz
f_{SYS_USB}	System and core clock when Full Speed USB in operation	20	—	MHz
f_{BUS}	Bus clock	—	50	MHz
f_{FLASH}	Flash clock	—	26.67	MHz
f_{LPTMR}	LPTMR clock	—	25	MHz
VLPR and VLPS modes ¹				
f_{SYS}	System and core clock	—	4	MHz
f_{BUS}	Bus clock	—	4	MHz
f_{FLASH}	Flash clock	—	1	MHz
f_{ERCLK}	External reference clock	—	16	MHz
f_{LPTMR_pin}	LPTMR clock	—	25	MHz
f_{LPTMR_ERCLK}	LPTMR external reference clock	—	16	MHz
f_{I2S_MCLK}	I2S master clock	—	12.5	MHz
f_{I2S_BCLK}	I2S bit clock	—	4	MHz
f_{FlexIO}	FlexIO clock	—	16	MHz
f_{LPI2C}	LPI2C clock	—	16	MHz
$f_{FlexCAN}$	FlexCAN clock	—	4	MHz

1. The frequency limitations in VLPR and VLPS modes here override any frequency specification listed in the timing specification for any other module. These same frequency limits apply to VLPS, whether VLPS was entered from RUN or from VLPR.

5.3.3.2 General switching specifications

These general purpose specifications apply to all signals configured for GPIO, UART, and timers.

Table 49. General switching specifications

Symbol	Description	Min.	Max.	Unit	Notes
	GPIO pin interrupt pulse width (digital glitch filter disabled) — Synchronous path	1.5	—	Bus clock cycles	1, 2
	External RESET and NMI pin interrupt pulse width — Asynchronous path	100	—	ns	3

Table continues on the next page...

Table 49. General switching specifications (continued)

Symbol	Description	Min.	Max.	Unit	Notes
	GPIO pin interrupt pulse width (digital glitch filter disabled, passive filter disabled) — Asynchronous path	50	—	ns	4
	Port rise and fall time <ul style="list-style-type: none"> • Slew disabled <ul style="list-style-type: none"> • $1.71 \leq V_{DD} \leq 2.7V$ • $2.7 \leq V_{DD} \leq 3.6V$ • Slew enabled <ul style="list-style-type: none"> • $1.71 \leq V_{DD} \leq 2.7V$ • $2.7 \leq V_{DD} \leq 3.6V$ 	—			5
		—	10	ns	
		—	5	ns	
		—	30	ns	
		—	16	ns	

1. This is the minimum pulse width that is guaranteed to pass through the pin synchronization circuitry. Shorter pulses may or may not be recognized. In Stop, VLPS, LLS, and VLLSx modes, the synchronizer is bypassed so shorter pulses can be recognized in that case.
2. The greater of synchronous and asynchronous timing must be met.
3. These pins have a passive filter enabled on the inputs. This is the shortest pulse width that is guaranteed to be recognized.
4. These pins do not have a passive filter on the inputs. This is the shortest pulse width that is guaranteed to be recognized.
5. 25 pF load

5.3.4 Thermal specification

5.3.4.1 Thermal operating requirements

Table 50. Thermal operating requirements

Symbol	Description	Min.	Max.	Unit	Notes
T_J	Die junction temperature	-40	125	°C	
T_A	Ambient temperature	-40	105	°C	1

1. Maximum T_A can be exceeded only if the user ensures that T_J does not exceed maximum T_J . The simplest method to determine T_J is: $T_J = T_A + R_{\theta JA} \times \text{chip power dissipation}$.

5.3.4.2 Thermal attributes

Table 51. Thermal attributes

Board type	Symbol	Description	100 LQFP	64 LQFP	48 QFN	Unit	Notes
Single-layer (1s)	$R_{\theta JA}$	Thermal resistance, junction to ambient (natural convection)	58	61	81	°C/W	1, 2, 3

Table continues on the next page...

Table 51. Thermal attributes (continued)

Board type	Symbol	Description	100 LQFP	64 LQFP	48 QFN	Unit	Notes
Four-layer (2s2p)	$R_{\theta JA}$	Thermal resistance, junction to ambient (natural convection)	46	43	28	°C/W	1, 2, 3,4
Single-layer (1s)	$R_{\theta JMA}$	Thermal resistance, junction to ambient (200 ft./min. air speed)	48	49	66	°C/W	1, 4, 5
Four-layer (2s2p)	$R_{\theta JMA}$	Thermal resistance, junction to ambient (200 ft./min. air speed)	40	36	23	°C/W	1, 4, 5
—	$R_{\theta JB}$	Thermal resistance, junction to board	31	25	11	°C/W	6
—	$R_{\theta JC}$	Thermal resistance, junction to case	16	13	1.3	°C/W	7
—	Ψ_{JT}	Thermal characterization parameter, junction to package top outside center (natural convection)	2	2	2	°C/W	8
—	Ψ_{JB}	Thermal characterization parameter, junction to package bottom (natural convection)	-	-	-	°C/W	9

1. Junction temperature is a function of die size, on-chip power dissipation, package thermal resistance, mounting site (board) temperature, ambient temperature, air flow, power dissipation of other components on the board, and board thermal resistance.
2. Per SEMI G38-87 and JEDEC JESD51-2 with the single layer board horizontal.
3. Per JEDEC JESD51-2 with natural convection for horizontally oriented board. Board meets JESD51-9 specification for 1s or 2s2p board, respectively.
4. Per JEDEC JESD51-6 with the board horizontal.
5. Per JEDEC JESD51-6 with forced convection for horizontally oriented board. Board meets JESD51-9 specification for 1s or 2s2p board, respectively.
6. Thermal resistance between the die and the printed circuit board per JEDEC JESD51-8. Board temperature is measured on the top surface of the board near the package.
7. Thermal resistance between the die and the case top surface as measured by the cold plate method (MIL SPEC-883 Method 1012.1).
8. Thermal characterization parameter indicating the temperature difference between package top and the junction temperature per JEDEC JESD51-2. When Greek letters are not available, the thermal characterization parameter is written as Psi-JT.
9. Thermal characterization parameter indicating the temperature difference between package bottom center and the junction temperature per JEDEC JESD51-12. When Greek letters are not available, the thermal characterization parameter is written as Psi-JB.

5.4 Peripheral operating requirements and behaviors

5.4.1 Debug modules

5.4.1.1 SWD electricals

Table 52. SWD full voltage range electricals

Symbol	Description	Min.	Max.	Unit
	Operating voltage	1.71	3.6	V
S1	SWD_CLK frequency of operation <ul style="list-style-type: none"> Serial wire debug 	0	33	MHz
S2	SWD_CLK cycle period	1/S1	—	ns
S3	SWD_CLK clock pulse width <ul style="list-style-type: none"> Serial wire debug 	15	—	ns
S4	SWD_CLK rise and fall times	—	3	ns
S9	SWD_DIO input data setup time to SWD_CLK rise	8	—	ns
S10	SWD_DIO input data hold time after SWD_CLK rise	1.4	—	ns
S11	SWD_CLK high to SWD_DIO data valid	—	25	ns
S12	SWD_CLK high to SWD_DIO high-Z	5	—	ns

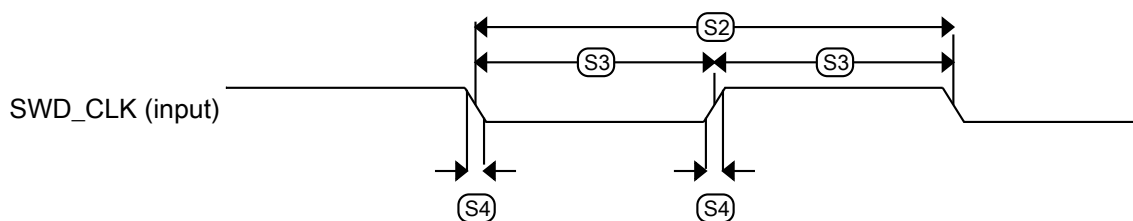

Figure 18. Serial wire clock input timing

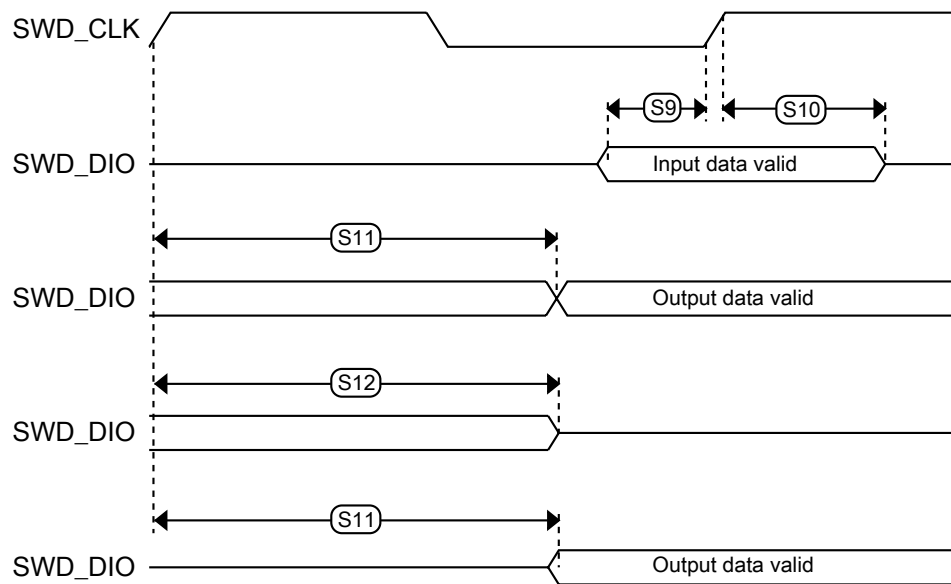

Figure 19. Serial wire data timing

5.4.1.2 JTAG electricals

Table 53. JTAG limited voltage range electricals

Symbol	Description	Min.	Max.	Unit
	Operating voltage	2.7	3.6	V
J1	TCLK frequency of operation <ul style="list-style-type: none"> • Boundary Scan • JTAG and CJTAG 	0 0	10 20	MHz
J2	TCLK cycle period	1/J1	—	ns
J3	TCLK clock pulse width <ul style="list-style-type: none"> • Boundary Scan • JTAG and CJTAG 	50 25	— —	ns ns
J4	TCLK rise and fall times	—	3	ns
J5	Boundary scan input data setup time to TCLK rise	20	—	ns
J6	Boundary scan input data hold time after TCLK rise	1	—	ns
J7	TCLK low to boundary scan output data valid	—	25	ns
J8	TCLK low to boundary scan output high-Z	—	25	ns
J9	TMS, TDI input data setup time to TCLK rise	8	—	ns
J10	TMS, TDI input data hold time after TCLK rise	1	—	ns

Table continues on the next page...

Table 53. JTAG limited voltage range electricals (continued)

Symbol	Description	Min.	Max.	Unit
J11	TCLK low to TDO data valid	—	19	ns
J12	TCLK low to TDO high-Z	—	19	ns
J13	$\overline{\text{TRST}}$ assert time	100	—	ns
J14	$\overline{\text{TRST}}$ setup time (negation) to TCLK high	8	—	ns

Table 54. JTAG full voltage range electricals

Symbol	Description	Min.	Max.	Unit
	Operating voltage	1.71	3.6	V
J1	TCLK frequency of operation <ul style="list-style-type: none"> • Boundary Scan • JTAG and CJTAG 	0 0	10 15	MHz
J2	TCLK cycle period	1/J1	—	ns
J3	TCLK clock pulse width <ul style="list-style-type: none"> • Boundary Scan • JTAG and CJTAG 	50 33	— —	ns ns
J4	TCLK rise and fall times	—	3	ns
J5	Boundary scan input data setup time to TCLK rise	20	—	ns
J6	Boundary scan input data hold time after TCLK rise	1.4	—	ns
J7	TCLK low to boundary scan output data valid	—	27	ns
J8	TCLK low to boundary scan output high-Z	—	27	ns
J9	TMS, TDI input data setup time to TCLK rise	8	—	ns
J10	TMS, TDI input data hold time after TCLK rise	1.4	—	ns
J11	TCLK low to TDO data valid	—	26.2	ns
J12	TCLK low to TDO high-Z	—	26.2	ns
J13	$\overline{\text{TRST}}$ assert time	100	—	ns
J14	$\overline{\text{TRST}}$ setup time (negation) to TCLK high	8	—	ns

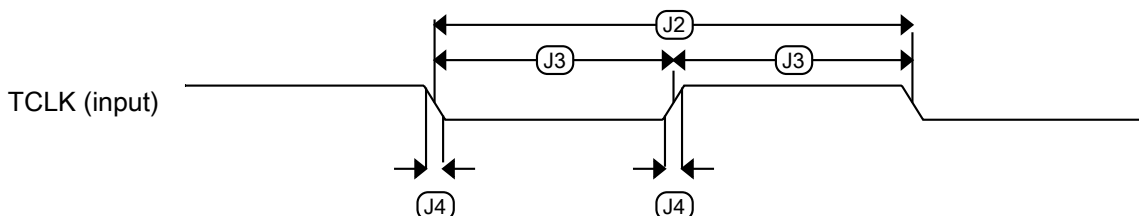

Figure 20. Test clock input timing

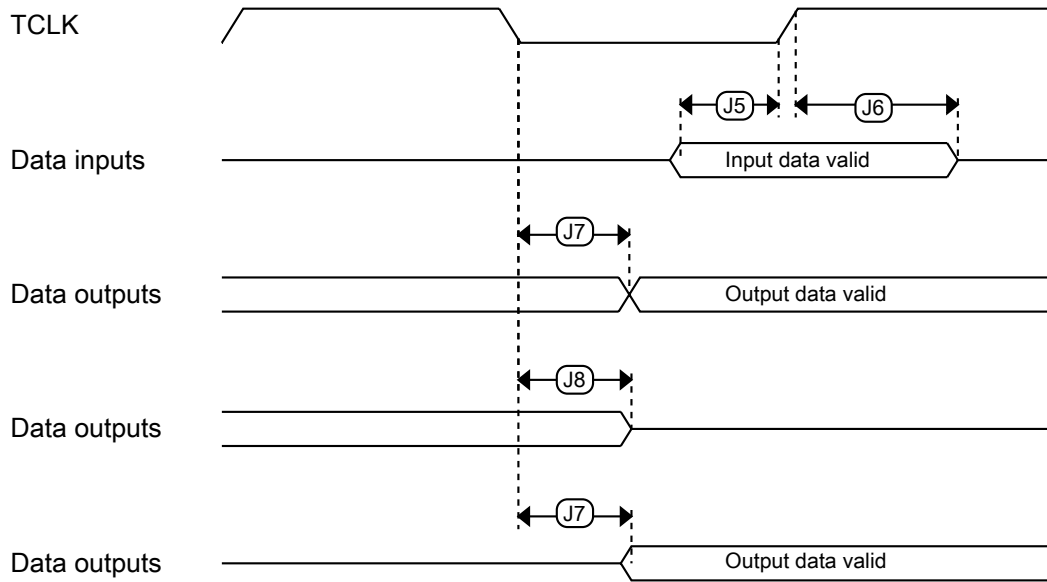

Figure 21. Boundary scan (JTAG) timing

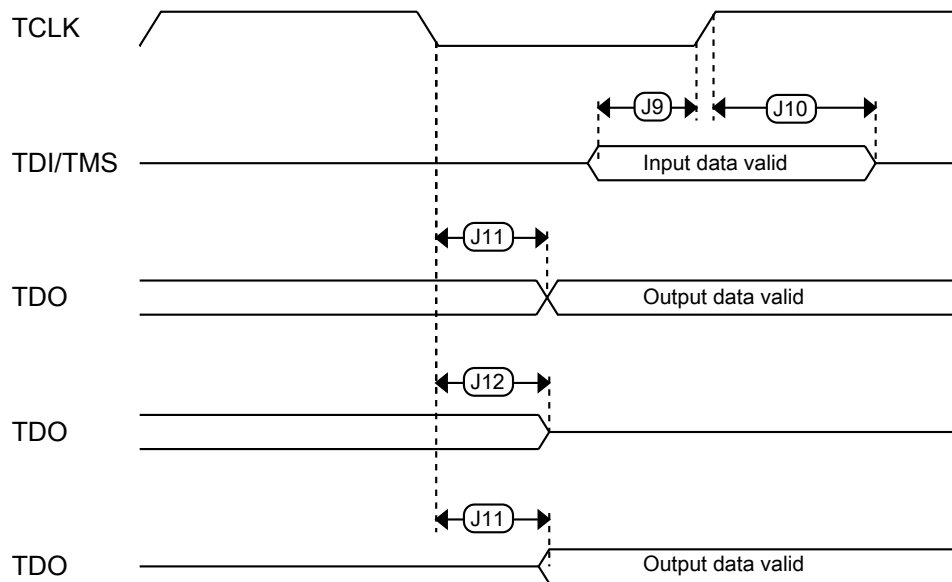

Figure 22. Test Access Port timing

Electrical characteristics

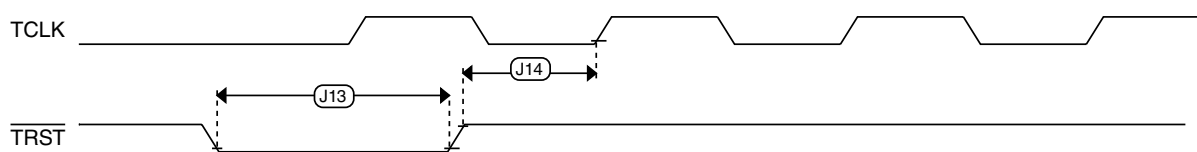

Figure 23. TRST timing

5.4.2 System modules

There are no specifications necessary for the device's system modules.

5.4.3 Clock modules

5.4.3.1 MCG specifications

Table 55. MCG specifications

Symbol	Description	Min.	Typ.	Max.	Unit	Notes
$f_{\text{ints_ft}}$	Internal reference frequency (slow clock) — factory trimmed at nominal VDD and 25 °C	—	32.768	—	kHz	
$\Delta f_{\text{ints_t}}$	Total deviation of internal reference frequency (slow clock) over voltage and temperature	—	+0.5/-0.7	± 2	%	
$f_{\text{ints_t}}$	Internal reference frequency (slow clock) — user trimmed	31.25	—	39.0625	kHz	
$\Delta f_{\text{dco_res_t}}$	Resolution of trimmed average DCO output frequency at fixed voltage and temperature — using SCTRIM and SCFTRIM	—	± 0.3	± 0.6	% f_{dco}	1
$\Delta f_{\text{dco_t}}$	Total deviation of trimmed average DCO output frequency over voltage and temperature	—	+0.5/-0.7	± 2	% f_{dco}	1, 2
$\Delta f_{\text{dco_t}}$	Total deviation of trimmed average DCO output frequency over fixed voltage and temperature range of 0–70°C	—	± 0.3	± 1.5	% f_{dco}	1
$f_{\text{intf_ft}}$	Internal reference frequency (fast clock) — factory trimmed at nominal VDD and 25°C	—	4	—	MHz	
$\Delta f_{\text{intf_ft}}$	Frequency deviation of internal reference clock (fast clock) over temperature and voltage — factory trimmed at nominal VDD and 25 °C	—	+1/-2	± 5	% $f_{\text{intf_ft}}$	
$f_{\text{intf_t}}$	Internal reference frequency (fast clock) — user trimmed at nominal VDD and 25 °C	3	—	5	MHz	
$f_{\text{loc_low}}$	Loss of external clock minimum frequency — RANGE = 00	$(3/5) \times f_{\text{ints_t}}$	—	—	kHz	

Table continues on the next page...

Table 55. MCG specifications (continued)

Symbol	Description	Min.	Typ.	Max.	Unit	Notes	
f_{loc_high}	Loss of external clock minimum frequency — RANGE = 01, 10, or 11	$(16/5) \times f_{ints_t}$	—	—	kHz		
FLL							
f_{fill_ref}	FLL reference frequency range	31.25	—	39.0625	kHz		
f_{dco}	DCO output frequency range	Low range (DRS=00) $640 \times f_{fill_ref}$	20	20.97	25	MHz	3, 4
		Mid range (DRS=01) $1280 \times f_{fill_ref}$	40	41.94	50	MHz	
		Mid-high range (DRS=10) $1920 \times f_{fill_ref}$	60	62.91	75	MHz	
		High range (DRS=11) $2560 \times f_{fill_ref}$	80	83.89	100	MHz	
$f_{dco_t_DMX3_2}$	DCO output frequency	Low range (DRS=00) $732 \times f_{fill_ref}$	—	23.99	—	MHz	5, 6
		Mid range (DRS=01) $1464 \times f_{fill_ref}$	—	47.97	—	MHz	
		Mid-high range (DRS=10) $2197 \times f_{fill_ref}$	—	71.99	—	MHz	
		High range (DRS=11) $2929 \times f_{fill_ref}$	—	95.98	—	MHz	
J_{cyc_fll}	FLL period jitter • $f_{VCO} = 48$ MHz • $f_{VCO} = 98$ MHz	— —	— 180 150	— —	ps		
$t_{fill_acquire}$	FLL target frequency acquisition time	—	—	1	ms	7	
PLL							
f_{vco}	VCO operating frequency	48.0	—	120	MHz		
I_{pll}	PLL operating current • PLL @ 96 MHz ($f_{osc_hi_1} = 8$ MHz, $f_{pll_ref} = 2$ MHz, VDIV multiplier = 48)	—	1060	—	μ A	8	
I_{pll}	PLL operating current • PLL @ 48 MHz ($f_{osc_hi_1} = 8$ MHz, $f_{pll_ref} = 2$ MHz, VDIV multiplier = 24)	—	600	—	μ A	8	
f_{pll_ref}	PLL reference frequency range	2.0	—	4.0	MHz		
J_{cyc_pll}	PLL period jitter (RMS) • $f_{vco} = 48$ MHz • $f_{vco} = 100$ MHz	—	120	—	ps	9	
		—	75	—	ps		
J_{acc_pll}	PLL accumulated jitter over 1 μ s (RMS)	—	1350	—	ps	9	

Table continues on the next page...

Table 55. MCG specifications (continued)

Symbol	Description	Min.	Typ.	Max.	Unit	Notes
	<ul style="list-style-type: none"> $f_{VCO} = 48 \text{ MHz}$ $f_{VCO} = 100 \text{ MHz}$ 	—	600	—	ps	
D_{lock}	Lock entry frequency tolerance	± 1.49	—	± 2.98	%	
D_{unl}	Lock exit frequency tolerance	± 4.47	—	± 5.97	%	
t_{pll_lock}	Lock detector detection time	—	—	$150 \times 10^{-6} + 1075(1/f_{pll_ref})$	s	10

1. This parameter is measured with the internal reference (slow clock) being used as a reference to the FLL (FEI clock mode).
2. $2.0 \text{ V} \leq VDD \leq 3.6 \text{ V}$.
3. These typical values listed are with the slow internal reference clock (FEI) using factory trim and DMX32=0.
4. The resulting system clock frequencies should not exceed their maximum specified values. The DCO frequency deviation (Δf_{dco_t}) over voltage and temperature should be considered.
5. These typical values listed are with the slow internal reference clock (FEI) using factory trim and DMX32=1.
6. The resulting clock frequency must not exceed the maximum specified clock frequency of the device.
7. This specification applies to any time the FLL reference source or reference divider is changed, trim value is changed, DMX32 bit is changed, DRS bits are changed, or changing from FLL disabled (BLPE, BLPI) to FLL enabled (FEI, FEE, FBE, FBI). If a crystal/resonator is being used as the reference, this specification assumes it is already running.
8. Excludes any oscillator currents that are also consuming power while PLL is in operation.
9. This specification was obtained using a NXP developed PCB. PLL jitter is dependent on the noise characteristics of each PCB and results will vary.
10. This specification applies to any time the PLL VCO divider or reference divider is changed, or changing from PLL disabled (BLPE, BLPI) to PLL enabled (PBE, PEE). If a crystal/resonator is being used as the reference, this specification assumes it is already running.

5.4.3.2 IRC48M specifications

Table 56. IRC48M specifications

Symbol	Description	Min.	Typ.	Max.	Unit	Notes
V_{DD}	Supply voltage	1.71	—	3.6	V	
I_{DD48M}	Supply current	—	400	500	μA	
f_{irc48m}	Internal reference frequency	—	48	—	MHz	
$\Delta f_{irc48m_ol_hv}$	Open loop total deviation of IRC48M frequency at high voltage ($VDD=1.89\text{V}-3.6\text{V}$) over 0°C to 70°C Regulator enable ($USB_CLK_RECOVER_IRC_EN[REG_EN]=1$)	—	± 0.2	± 0.5	$\%f_{irc48m}$	1
$\Delta f_{irc48m_ol_hv}$	Open loop total deviation of IRC48M frequency at high voltage ($VDD=1.89\text{V}-3.6\text{V}$) over full temperature Regulator enable ($USB_CLK_RECOVER_IRC_EN[REG_EN]=1$)	—	± 0.4	± 1.0	$\%f_{irc48m}$	1
$\Delta f_{irc48m_ol_lv}$	Open loop total deviation of IRC48M frequency at low voltage ($VDD=1.71\text{V}-1.89\text{V}$) over full temperature Regulator disable ($USB_CLK_RECOVER_IRC_EN[REG_EN]=0$)	—	± 0.4	± 1.0	$\%f_{irc48m}$	1

Table continues on the next page...

Table 56. IRC48M specifications (continued)

Symbol	Description	Min.	Typ.	Max.	Unit	Notes
	Regulator enable (USB_CLK_RECOVER_IRC_EN[REG_EN]=1)	—	± 0.5	± 1.5		
Δf_{irc48m_cl}	Closed loop total deviation of IRC48M frequency over voltage and temperature	—	—	± 0.1	% f_{host}	2
J_{cyc_irc48m}	Period Jitter (RMS)	—	35	150	ps	
$t_{irc48mst}$	Startup time	—	2	3	µs	3

- The maximum value represents characterized results equivalent to the mean plus or minus three times the standard deviation (mean ± 3 sigma).
- Closed loop operation of the IRC48M is only feasible for USB device operation; it is not usable for USB host operation. It is enabled by configuring for USB Device, selecting IRC48M as USB clock source, and enabling the clock recover function (USB_CLK_RECOVER_IRC_CTRL[CLOCK_RECOVER_EN]=1, USB_CLK_RECOVER_IRC_EN[IRC_EN]=1).
- IRC48M startup time is defined as the time between clock enablement and clock availability for system use. Enable the clock by one of the following settings:
 - USB_CLK_RECOVER_IRC_EN[IRC_EN]=1 or
 - MCG operating in an external clocking mode and MCG_C7[OSCSSEL]=10 or MCG_C5[PLLCLKEN0]=1, or
 - SIM_SOPT2[PLLFLLSEL]=11

5.4.3.3 Oscillator electrical specifications

5.4.3.3.1 Oscillator DC electrical specifications

Table 57. Oscillator DC electrical specifications

Symbol	Description	Min.	Typ.	Max.	Unit	Notes
V_{DD}	Supply voltage	1.71	—	3.6	V	
I_{DDOSC}	Supply current — low-power mode (HGO=0) <ul style="list-style-type: none"> 32 kHz 4 MHz 8 MHz (RANGE=01) 16 MHz 24 MHz 32 MHz 	—	500	—	nA	1
		—	200	—	µA	
		—	300	—	µA	
		—	950	—	µA	
		—	1.2	—	mA	
		—	1.5	—	mA	
I_{DDOSC}	Supply current — high-gain mode (HGO=1) <ul style="list-style-type: none"> 32 kHz 4 MHz 8 MHz (RANGE=01) 16 MHz 	—	25	—	µA	1
		—	400	—	µA	
		—	500	—	µA	
		—	2.5	—	mA	
		—	3	—	mA	

Table continues on the next page...

Table 57. Oscillator DC electrical specifications (continued)

Symbol	Description	Min.	Typ.	Max.	Unit	Notes
	<ul style="list-style-type: none"> • 24 MHz • 32 MHz 	—	4	—	mA	
C_x	EXTAL load capacitance	—	—	—		2, 3
C_y	XTAL load capacitance	—	—	—		2, 3
R_F	Feedback resistor — low-frequency, low-power mode (HGO=0)	—	—	—	M Ω	2, 4
	Feedback resistor — low-frequency, high-gain mode (HGO=1)	—	10	—	M Ω	
	Feedback resistor — high-frequency, low-power mode (HGO=0)	—	—	—	M Ω	
	Feedback resistor — high-frequency, high-gain mode (HGO=1)	—	1	—	M Ω	
R_S	Series resistor — low-frequency, low-power mode (HGO=0)	—	—	—	k Ω	
	Series resistor — low-frequency, high-gain mode (HGO=1)	—	200	—	k Ω	
	Series resistor — high-frequency, low-power mode (HGO=0)	—	—	—	k Ω	
	Series resistor — high-frequency, high-gain mode (HGO=1)	—	0	—	k Ω	
V_{pp}^5	Peak-to-peak amplitude of oscillation (oscillator mode) — low-frequency, low-power mode (HGO=0)	—	0.6	—	V	
	Peak-to-peak amplitude of oscillation (oscillator mode) — low-frequency, high-gain mode (HGO=1)	—	V_{DD}	—	V	
	Peak-to-peak amplitude of oscillation (oscillator mode) — high-frequency, low-power mode (HGO=0)	—	0.6	—	V	
	Peak-to-peak amplitude of oscillation (oscillator mode) — high-frequency, high-gain mode (HGO=1)	—	V_{DD}	—	V	

1. $V_{DD}=3.3$ V, Temperature =25 °C
2. See crystal or resonator manufacturer's recommendation.
3. C_x and C_y can be provided by using either integrated capacitors or external components.
4. When low-power mode is selected, R_F is integrated and must not be attached externally.
5. The EXTAL and XTAL pins should only be connected to required oscillator components and must not be connected to any other device.

5.4.3.3.2 Oscillator frequency specifications

Table 58. Oscillator frequency specifications

Symbol	Description	Min.	Typ.	Max.	Unit	Notes
f_{osc_lo}	Oscillator crystal or resonator frequency — low-frequency mode (MCG_C2[RANGE]=00)	32	—	40	kHz	
$f_{osc_hi_1}$	Oscillator crystal or resonator frequency — high-frequency mode (low range) (MCG_C2[RANGE]=01)	3	—	8	MHz	
$f_{osc_hi_2}$	Oscillator crystal or resonator frequency — high frequency mode (high range) (MCG_C2[RANGE]=1x)	8	—	32	MHz	
f_{ec_extal}	Input clock frequency (external clock mode)	—	—	50	MHz	1, 2
t_{dc_extal}	Input clock duty cycle (external clock mode)	40	50	60	%	
t_{cst}	Crystal startup time — 32 kHz low-frequency, low-power mode (HGO=0)	—	750	—	ms	3, 4
	Crystal startup time — 32 kHz low-frequency, high-gain mode (HGO=1)	—	250	—	ms	
	Crystal startup time — 8 MHz high-frequency (MCG_C2[RANGE]=01), low-power mode (HGO=0)	—	0.6	—	ms	
	Crystal startup time — 8 MHz high-frequency (MCG_C2[RANGE]=01), high-gain mode (HGO=1)	—	1	—	ms	

1. Other frequency limits may apply when external clock is being used as a reference for the FLL or PLL.
2. When transitioning from FEI or FBI to FBE mode, restrict the frequency of the input clock so that, when it is divided by FRDIV, it remains within the limits of the DCO input clock frequency.
3. Proper PC board layout procedures must be followed to achieve specifications.
4. Crystal startup time is defined as the time between the oscillator being enabled and the OSCINIT bit in the MCG_S register being set.

5.4.3.4 32 kHz oscillator electrical characteristics

5.4.3.4.1 32 kHz oscillator DC electrical specifications

Table 59. 32 kHz oscillator DC electrical specifications

Symbol	Description	Min.	Typ.	Max.	Unit
V_{BAT}	Supply voltage	1.71	—	3.6	V
R_F	Internal feedback resistor	—	100	—	M Ω
C_{para}	Parasitical capacitance of EXTAL32 and XTAL32	—	5	7	pF
V_{pp}^1	Peak-to-peak amplitude of oscillation	—	0.6	—	V

1. When a crystal is being used with the 32 kHz oscillator, the EXTAL32 and XTAL32 pins should only be connected to required oscillator components and must not be connected to any other devices.

5.4.3.4.2 32 kHz oscillator frequency specifications

Table 60. 32 kHz oscillator frequency specifications

Symbol	Description	Min.	Typ.	Max.	Unit	Notes
f_{osc_lo}	Oscillator crystal	—	32.768	—	kHz	
t_{start}	Crystal start-up time	—	1000	—	ms	1
$f_{ec_extal32}$	Externally provided input clock frequency	—	32.768	—	kHz	2
$V_{ec_extal32}$	Externally provided input clock amplitude	700	—	V_{BAT}	mV	2, 3

1. Proper PC board layout procedures must be followed to achieve specifications.
2. This specification is for an externally supplied clock driven to EXTAL32 and does not apply to any other clock input. The oscillator remains enabled and XTAL32 must be left unconnected.
3. The parameter specified is a peak-to-peak value and V_{IH} and V_{IL} specifications do not apply. The voltage of the applied clock must be within the range of V_{SS} to V_{BAT} .

5.4.4 Memories and memory interfaces

5.4.4.1 Flash electrical specifications

This section describes the electrical characteristics of the flash memory module.

5.4.4.1.1 Flash timing specifications — program and erase

The following specifications represent the amount of time the internal charge pumps are active and do not include command overhead.

Table 61. NVM program/erase timing specifications

Symbol	Description	Min.	Typ.	Max.	Unit	Notes
t_{hvp4}	Longword Program high-voltage time	—	7.5	18	μ s	—
$t_{hversscr}$	Sector Erase high-voltage time	—	13	113	ms	1
$t_{hversall}$	Erase All high-voltage time	—	104	904	ms	1

1. Maximum time based on expectations at cycling end-of-life.

5.4.4.1.2 Flash timing specifications — commands

Table 62. Flash command timing specifications

Symbol	Description	Min.	Typ.	Max.	Unit	Notes
$t_{rd1sec2k}$	Read 1s Section execution time (flash sector)	—	—	60	μ s	1
t_{pgmchk}	Program Check execution time	—	—	45	μ s	1
t_{rdsrc}	Read Resource execution time	—	—	30	μ s	1

Table continues on the next page...

Table 62. Flash command timing specifications (continued)

Symbol	Description	Min.	Typ.	Max.	Unit	Notes
t_{pgm4}	Program Longword execution time	—	65	145	μ s	—
t_{ersscr}	Erase Flash Sector execution time	—	14	114	ms	2
t_{rd1all}	Read 1s All Blocks execution time	—	—	1.8	ms	1
t_{rdonce}	Read Once execution time	—	—	30	μ s	1
$t_{pgmonce}$	Program Once execution time	—	100	—	μ s	—
t_{ersall}	Erase All Blocks execution time	—	175	1300	ms	2
t_{vfykey}	Verify Backdoor Access Key execution time	—	—	30	μ s	1

1. Assumes 25 MHz flash clock frequency.
2. Maximum times for erase parameters based on expectations at cycling end-of-life.

5.4.4.1.3 Flash high voltage current behaviors

Table 63. Flash high voltage current behaviors

Symbol	Description	Min.	Typ.	Max.	Unit
I_{DD_PGM}	Average current adder during high voltage flash programming operation	—	2.5	6.0	mA
I_{DD_ERS}	Average current adder during high voltage flash erase operation	—	1.5	4.0	mA

5.4.4.1.4 Reliability specifications

Table 64. NVM reliability specifications

Symbol	Description	Min.	Typ. ¹	Max.	Unit	Notes
Program Flash						
$t_{nvmp10k}$	Data retention after up to 10 K cycles	5	50	—	years	—
t_{nvmp1k}	Data retention after up to 1 K cycles	20	100	—	years	—
n_{nvmp}	Cycling endurance	10 K	50 K	—	cycles	2

1. Typical data retention values are based on measured response accelerated at high temperature and derated to a constant 25 °C use profile. Engineering Bulletin EB618 does not apply to this technology. Typical endurance defined in Engineering Bulletin EB619.
2. Cycling endurance represents number of program/erase cycles at $-40\text{ °C} \leq T_j \leq 125\text{ °C}$.

5.4.5 Security and integrity modules

There are no specifications necessary for the device's security and integrity modules.

5.4.6 Analog

5.4.6.1 ADC electrical specifications

The 16-bit accuracy specifications listed in [Table 65](#) and [Table 66](#) are achievable on the differential pins ADCx_DPx, ADCx_DMx.

All other ADC channels meet the 13-bit differential/12-bit single-ended accuracy specifications.

5.4.6.1.1 16-bit ADC operating conditions

Table 65. 16-bit ADC operating conditions

Symbol	Description	Conditions	Min.	Typ. ¹	Max.	Unit	Notes
V _{DDA}	Supply voltage	Absolute	1.71	—	3.6	V	
ΔV _{DDA}	Supply voltage	Delta to V _{DD} (V _{DD} – V _{DDA})	-100	0	+100	mV	2
ΔV _{SSA}	Ground voltage	Delta to V _{SS} (V _{SS} – V _{SSA})	-100	0	+100	mV	2
V _{REFH}	ADC reference voltage high		1.13	V _{DDA}	V _{DDA}	V	
V _{REFL}	ADC reference voltage low		V _{SSA}	V _{SSA}	V _{SSA}	V	
V _{ADIN}	Input voltage	<ul style="list-style-type: none"> 16-bit differential mode All other modes 	V _{REFL} V _{REFL}	— —	31/32 * V _{REFH} V _{REFH}	V	
C _{ADIN}	Input capacitance	<ul style="list-style-type: none"> 16-bit mode 8-bit / 10-bit / 12-bit modes 	— —	8 4	10 5	pF	
R _{ADIN}	Input series resistance		—	2	5	kΩ	
R _{AS}	Analog source resistance (external)	13-bit / 12-bit modes f _{ADCK} < 4 MHz	—	—	5	kΩ	3
f _{ADCK}	ADC conversion clock frequency	≤ 13-bit mode	1.0	—	24.0	MHz	4
f _{ADCK}	ADC conversion clock frequency	16-bit mode	2.0	—	12.0	MHz	4
C _{rate}	ADC conversion rate	≤ 13-bit modes No ADC hardware averaging Continuous conversions enabled, subsequent conversion time	20	—	1200	Ksps	5
C _{rate}	ADC conversion rate	16-bit mode No ADC hardware averaging	37	—	461	Ksps	5

Table 65. 16-bit ADC operating conditions

Symbol	Description	Conditions	Min.	Typ. ¹	Max.	Unit	Notes
		Continuous conversions enabled, subsequent conversion time					

1. Typical values assume $V_{DDA} = 3.0\text{ V}$, $\text{Temp} = 25\text{ }^{\circ}\text{C}$, $f_{ADCK} = 1.0\text{ MHz}$, unless otherwise stated. Typical values are for reference only, and are not tested in production.
2. DC potential difference.
3. This resistance is external to MCU. To achieve the best results, the analog source resistance must be kept as low as possible. The results in this data sheet were derived from a system that had $< 8\ \Omega$ analog source resistance. The R_{AS}/C_{AS} time constant should be kept to $< 1\text{ ns}$.
4. To use the maximum ADC conversion clock frequency, $\text{CFG2}[\text{ADHSC}]$ must be set and $\text{CFG1}[\text{ADLPC}]$ must be clear.
5. For guidelines and examples of conversion rate calculation, download the [ADC calculator tool](#).

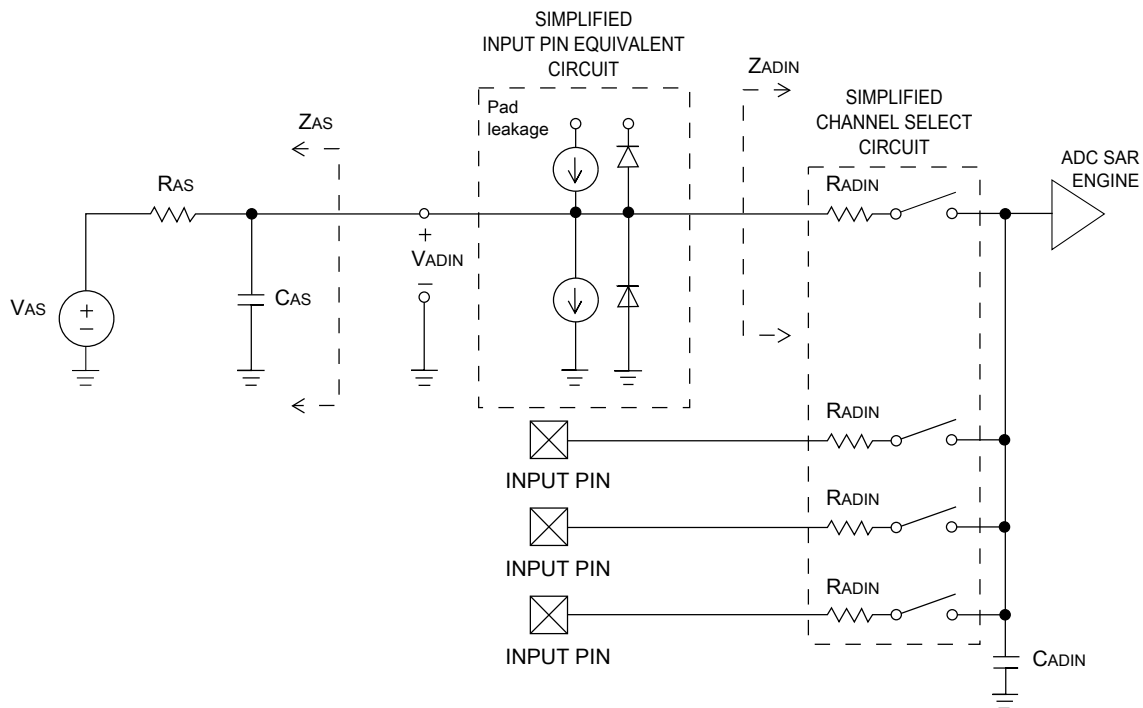
**Figure 24. ADC input impedance equivalency diagram**

5.4.6.1.2 16-bit ADC electrical characteristics

Table 66. 16-bit ADC characteristics ($V_{REFH} = V_{DDA}$, $V_{REFL} = V_{SSA}$)

Symbol	Description	Conditions ¹	Min.	Typ. ²	Max.	Unit	Notes
I_{DDA_ADC}	Supply current		0.215	—	1.7	mA	3
f_{ADACK}	ADC asynchronous clock source	• $\text{ADLPC} = 1$, $\text{ADHSC} = 0$	1.2	2.4	3.9	MHz	$t_{ADACK} = 1/f_{ADACK}$

Table continues on the next page...

Table 66. 16-bit ADC characteristics ($V_{REFH} = V_{DDA}$, $V_{REFL} = V_{SSA}$) (continued)

Symbol	Description	Conditions ¹	Min.	Typ. ²	Max.	Unit	Notes
		<ul style="list-style-type: none"> ADLPC = 1, ADHSC = 1 ADLPC = 0, ADHSC = 0 ADLPC = 0, ADHSC = 1 	2.4	4.0	6.1	MHz	
	Sample Time	See Reference Manual chapter for sample times					
TUE	Total unadjusted error	<ul style="list-style-type: none"> 12-bit modes <12-bit modes 	—	±4	±6.8	LSB ⁴	5
			—	±1.4	±2.1		
DNL	Differential non-linearity	<ul style="list-style-type: none"> 12-bit modes <12-bit modes 	—	±0.7	-1.1 to +1.9	LSB ⁴	5
			—	±0.2	-0.3 to 0.5		
INL	Integral non-linearity	<ul style="list-style-type: none"> 12-bit modes <12-bit modes 	—	±1.0	-2.7 to +1.9	LSB ⁴	5
			—	±0.5	-0.7 to +0.5		
E _{FS}	Full-scale error	<ul style="list-style-type: none"> 12-bit modes <12-bit modes 	—	-4	-5.4	LSB ⁴	V _{ADIN} = V _{DDA} ⁵
			—	-1.4	-1.8		
E _Q	Quantization error	<ul style="list-style-type: none"> 16-bit modes ≤13-bit modes 	—	-1 to 0	—	LSB ⁴	
			—	—	±0.5		
ENOB	Effective number of bits	16-bit differential mode <ul style="list-style-type: none"> Avg = 32 Avg = 4 16-bit single-ended mode <ul style="list-style-type: none"> Avg = 32 Avg = 4 	12.8	14.5	—	bits	6
			11.9	13.8	—	bits	
			12.2	13.9	—	bits	
			11.4	13.1	—	bits	
SINAD	Signal-to-noise plus distortion	See ENOB	6.02 × ENOB + 1.76			dB	
THD	Total harmonic distortion	16-bit differential mode <ul style="list-style-type: none"> Avg = 32 16-bit single-ended mode <ul style="list-style-type: none"> Avg = 32 	—	-94	—	dB	7
			—	-85	—	dB	
SFDR	Spurious free dynamic range	16-bit differential mode <ul style="list-style-type: none"> Avg = 32 16-bit single-ended mode <ul style="list-style-type: none"> Avg = 32 	82	95	—	dB	7
			78	90	—	dB	

Table continues on the next page...

Table 66. 16-bit ADC characteristics ($V_{REFH} = V_{DDA}$, $V_{REFL} = V_{SSA}$) (continued)

Symbol	Description	Conditions ¹	Min.	Typ. ²	Max.	Unit	Notes
E_{IL}	Input leakage error		$I_{in} \times R_{AS}$			mV	I_{in} = leakage current (refer to the MCU's voltage and current operating ratings)
	Temp sensor slope	Across the full temperature range of the device	1.55	1.62	1.69	mV/°C	8
V_{TEMP25}	Temp sensor voltage	25 °C	706	716	726	mV	8

1. All accuracy numbers assume the ADC is calibrated with $V_{REFH} = V_{DDA}$
2. Typical values assume $V_{DDA} = 3.0$ V, Temp = 25 °C, $f_{ADCK} = 2.0$ MHz unless otherwise stated. Typical values are for reference only and are not tested in production.
3. The ADC supply current depends on the ADC conversion clock speed, conversion rate and ADC_CFG1[ADLPC] (low power). For lowest power operation, ADC_CFG1[ADLPC] must be set, the ADC_CFG2[ADHSC] bit must be clear with 1 MHz ADC conversion clock speed.
4. $1 \text{ LSB} = (V_{REFH} - V_{REFL})/2^N$
5. ADC conversion clock < 16 MHz, Max hardware averaging (AVGE = %1, AVGS = %11)
6. Input data is 100 Hz sine wave. ADC conversion clock < 12 MHz.
7. Input data is 1 kHz sine wave. ADC conversion clock < 12 MHz.
8. ADC conversion clock < 3 MHz

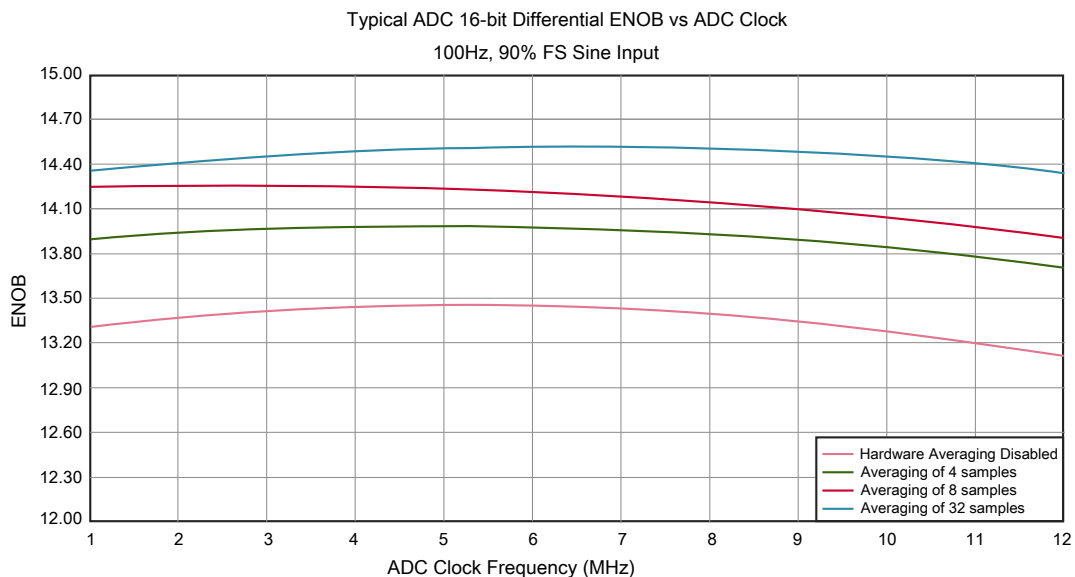
**Figure 25. Typical ENOB vs. ADC_CLK for 16-bit differential mode**

Electrical characteristics

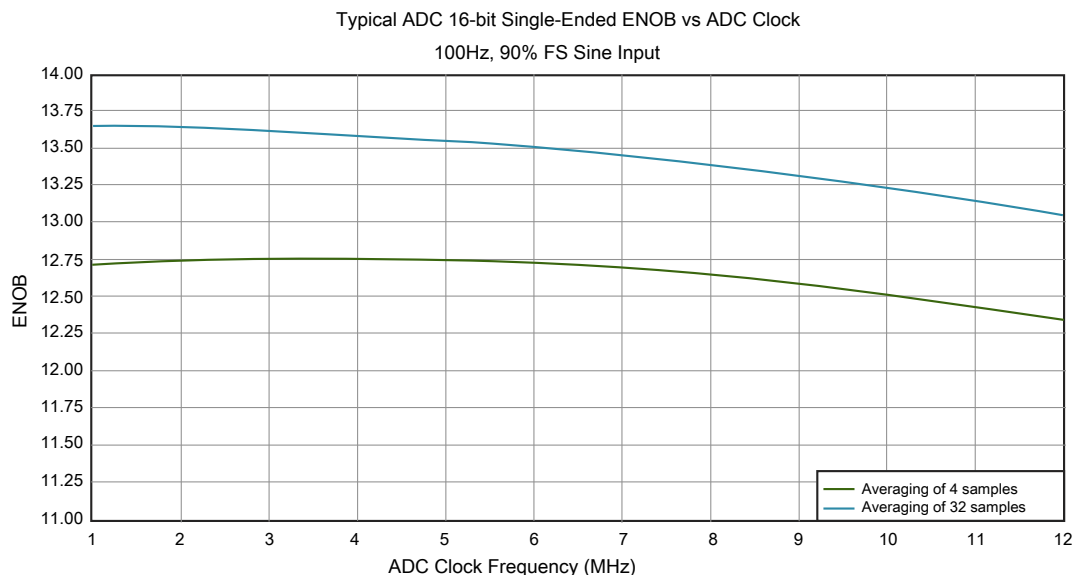

Figure 26. Typical ENOB vs. ADC_CLK for 16-bit single-ended mode

5.4.6.2 CMP and 6-bit DAC electrical specifications

Table 67. Comparator and 6-bit DAC electrical specifications

Symbol	Description	Min.	Typ.	Max.	Unit
V_{DD}	Supply voltage	1.71	—	3.6	V
I_{DDHS}	Supply current, high-speed mode (EN=1, PMODE=1)	—	—	200	μ A
$I_{DDL S}$	Supply current, low-speed mode (EN=1, PMODE=0)	—	—	20	μ A
V_{AIN}	Analog input voltage	$V_{SS} - 0.3$	—	V_{DD}	V
V_{AIO}	Analog input offset voltage	—	—	20	mV
V_H	Analog comparator hysteresis ¹				
	• CR0[HYSTCTR] = 00	—	5	—	mV
	• CR0[HYSTCTR] = 01	—	10	—	mV
	• CR0[HYSTCTR] = 10	—	20	—	mV
	• CR0[HYSTCTR] = 11	—	30	—	mV
V_{CMPOh}	Output high	$V_{DD} - 0.5$	—	—	V
V_{CMPOl}	Output low	—	—	0.5	V
t_{DHS}	Propagation delay, high-speed mode (EN=1, PMODE=1)	20	50	200	ns
t_{DLS}	Propagation delay, low-speed mode (EN=1, PMODE=0)	80	250	600	ns
	Analog comparator initialization delay ²	—	—	40	μ s
I_{DAC6b}	6-bit DAC current adder (enabled)	—	7	—	μ A
INL	6-bit DAC integral non-linearity	-0.5	—	0.5	LSB ³
DNL	6-bit DAC differential non-linearity	-0.3	—	0.3	LSB

1. Typical hysteresis is measured with input voltage range limited to 0.6 to $V_{DD}-0.6$ V.

2. Comparator initialization delay is defined as the time between software writes to change control inputs (Writes to CMP_DACCR[DACEN], CMP_DACCR[VRSEL], CMP_DACCR[VOSEL], CMP_MUXCR[PSEL], and CMP_MUXCR[MSEL]) and the comparator output settling to a stable level.
3. $1 \text{ LSB} = V_{\text{reference}}/64$

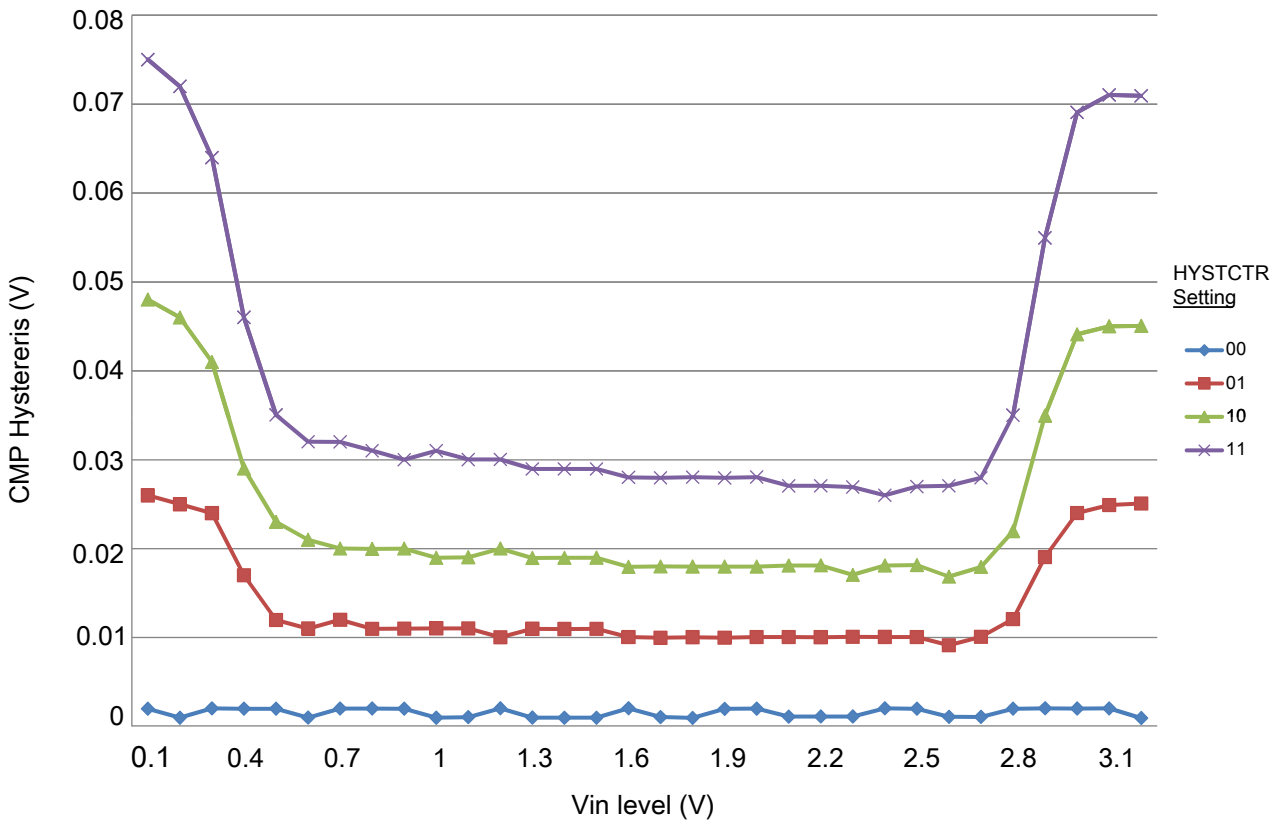

Figure 27. Typical hysteresis vs. Vin level (VDD = 3.3 V, PMODE = 0)

Electrical characteristics

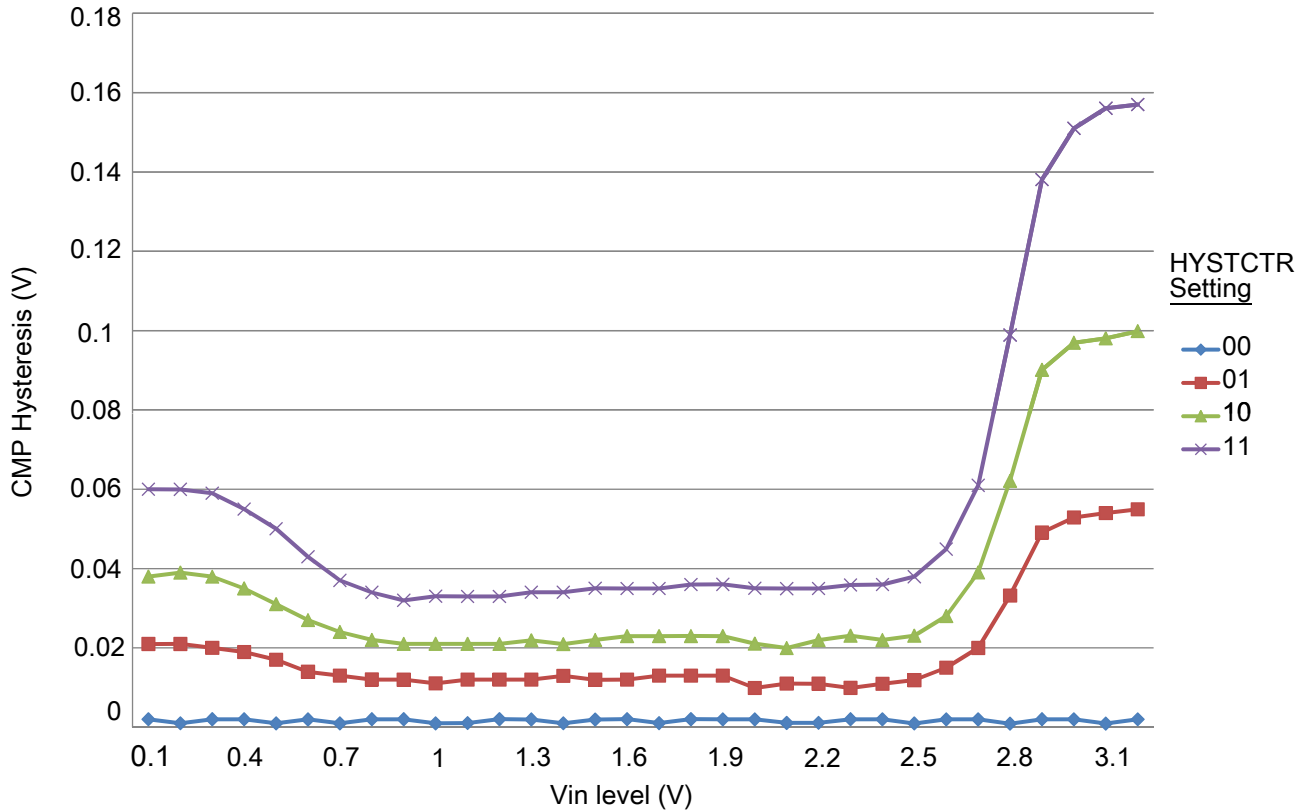

Figure 28. Typical hysteresis vs. Vin level (VDD = 3.3 V, PMODE = 1)

5.4.6.3 12-bit DAC electrical characteristics

5.4.6.3.1 12-bit DAC operating requirements

Table 68. 12-bit DAC operating requirements

Symbol	Description	Min.	Max.	Unit	Notes
V_{DDA}	Supply voltage	1.71	3.6	V	
V_{DACR}	Reference voltage	1.13	3.6	V	1
C_L	Output load capacitance	—	100	pF	2
I_L	Output load current	—	1	mA	

1. The DAC reference can be selected to be V_{DDA} or V_{REFH} .
2. A small load capacitance (47 pF) can improve the bandwidth performance of the DAC

5.4.6.3.2 12-bit DAC operating behaviors

Table 69. 12-bit DAC operating behaviors

Symbol	Description	Min.	Typ.	Max.	Unit	Notes
I_{DDA_DACLP}	Supply current — low-power mode	—	—	330	μA	
I_{DDA_DACHP}	Supply current — high-speed mode	—	—	1200	μA	
t_{DACLP}	Full-scale settling time (0x080 to 0xF7F) — low-power mode	—	100	200	μs	1
t_{DACHP}	Full-scale settling time (0x080 to 0xF7F) — high-power mode	—	15	30	μs	1
$t_{CCDACLP}$	Code-to-code settling time (0xBF8 to 0xC08) — low-power mode and high-speed mode	—	0.7	1	μs	1
$V_{dacoutl}$	DAC output voltage range low — high-speed mode, no load, DAC set to 0x000	—	—	100	mV	
$V_{dacouth}$	DAC output voltage range high — high-speed mode, no load, DAC set to 0xFFFF	$V_{DACR} - 100$	—	V_{DACR}	mV	
INL	Integral non-linearity error — high speed mode	—	—	± 8	LSB	2
DNL	Differential non-linearity error — $V_{DACR} > 2\text{ V}$	—	—	± 1	LSB	3
DNL	Differential non-linearity error — $V_{DACR} = V_{REF_OUT}$	—	—	± 1	LSB	4
V_{OFFSET}	Offset error	—	± 0.4	± 0.8	%FSR	5
E_G	Gain error	—	± 0.1	± 0.6	%FSR	5
PSRR	Power supply rejection ratio, $V_{DDA} \geq 2.4\text{ V}$	60	—	90	dB	
T_{CO}	Temperature coefficient offset voltage	—	3.7	—	$\mu\text{V}/\text{C}$	6
T_{GE}	Temperature coefficient gain error	—	0.000421	—	%FSR/C	
R_{op}	Output resistance (load = 3 k Ω)	—	—	250	Ω	
SR	Slew rate -80h → F7Fh → 80h <ul style="list-style-type: none"> High power (SP_{HP}) Low power (SP_{LP}) 	1.2 0.05	1.7 0.12	— —	V/ μs	
BW	3dB bandwidth <ul style="list-style-type: none"> High power (SP_{HP}) Low power (SP_{LP}) 	550 40	— —	— —	kHz	

- Settling within ± 1 LSB
- The INL is measured for 0 + 100 mV to $V_{DACR} - 100$ mV
- The DNL is measured for 0 + 100 mV to $V_{DACR} - 100$ mV
- The DNL is measured for 0 + 100 mV to $V_{DACR} - 100$ mV with $V_{DDA} > 2.4\text{ V}$
- Calculated by a best fit curve from $V_{SS} + 100$ mV to $V_{DACR} - 100$ mV
- $V_{DDA} = 3.0\text{ V}$, reference select set for V_{DDA} (DAC_X_CO:DACRFS = 1), high power mode (DAC_X_CO:LPEN = 0), DAC set to 0x800, temperature range is across the full range of the device

Electrical characteristics

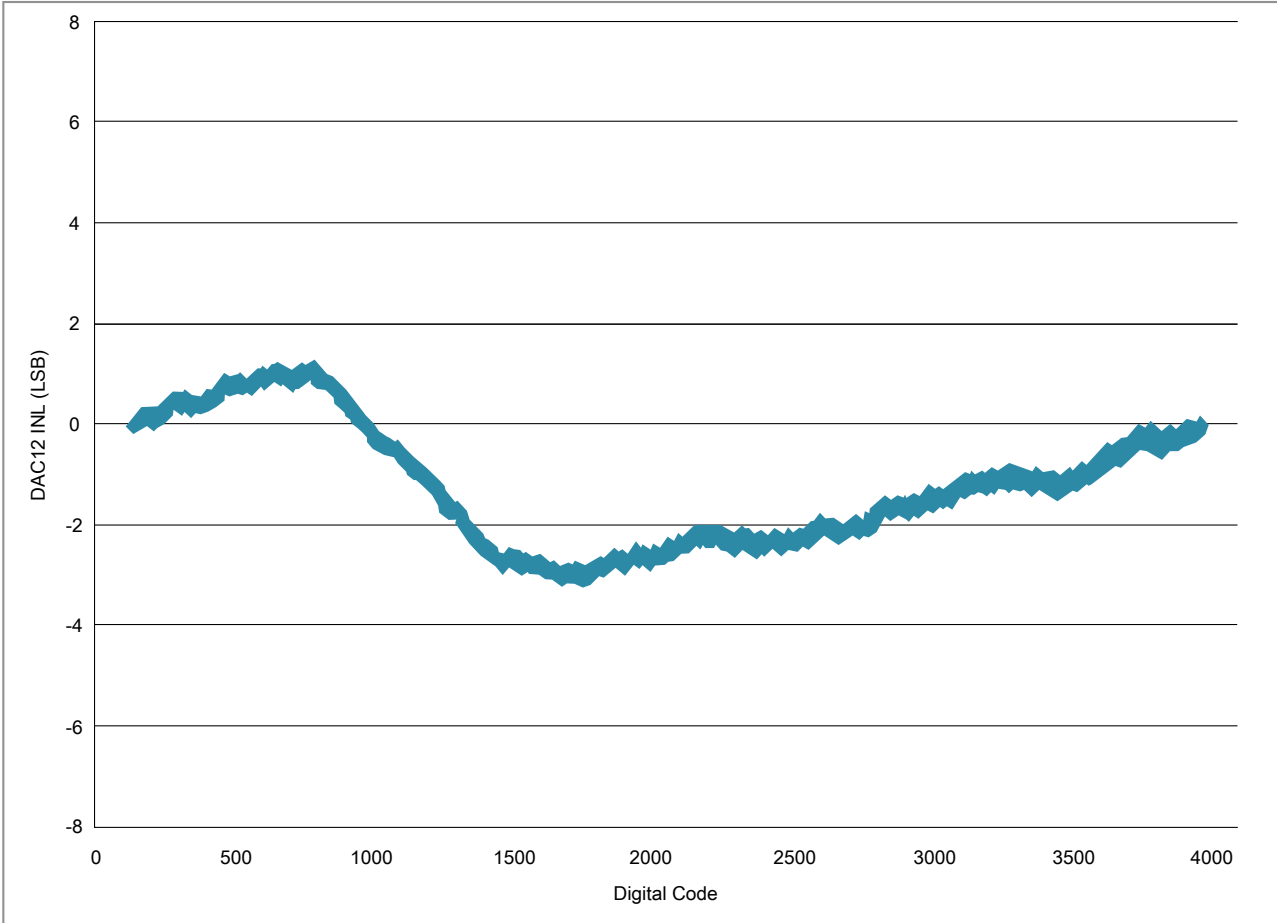

Figure 29. Typical INL error vs. digital code

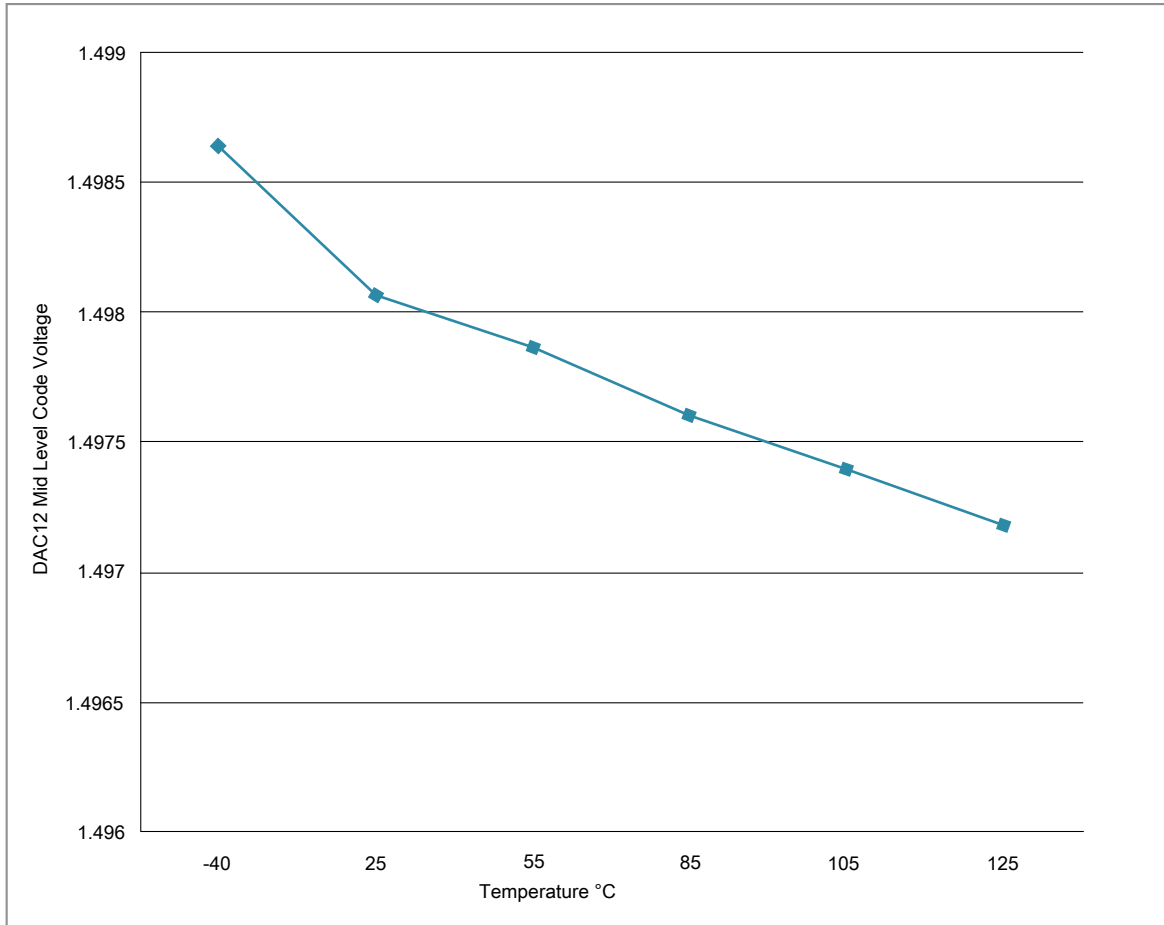

Figure 30. Offset at half scale vs. temperature

5.4.7 Timers

See [General switching specifications](#).

5.4.8 Communication interfaces

5.4.8.1 USB electrical specifications

The USB electricals for the USB On-the-Go module conform to the standards documented by the Universal Serial Bus Implementers Forum. For the most up-to-date standards, visit usb.org.

NOTE

The MCGPLLCLK meets the USB jitter and signaling rate specifications for certification with the use of an external clock/crystal for both Device and Host modes.

The MCGFLLCLK does not meet the USB jitter or signaling rate specifications for certification.

The IRC48M meets the USB jitter and signaling rate specifications for certification in Device mode when the USB clock recovery mode is enabled. It does not meet the USB signaling rate specifications for certification in Host mode operation.

5.4.8.2 DSPI switching specifications (limited voltage range)

The Deserial Serial Peripheral Interface (DSPI) provides a synchronous serial bus with master and slave operations. Many of the transfer attributes are programmable. The tables below provide DSPI timing characteristics for classic SPI timing modes. Refer to the SPI chapter of the Reference Manual for information on the modified transfer formats used for communicating with slower peripheral devices.

Table 70. Master mode DSPI timing (limited voltage range)

Num	Description	Min.	Max.	Unit	Notes
	Operating voltage	2.7	3.6	V	
	Frequency of operation	—	30	MHz	
DS1	DSPI_SCK output cycle time	$2 \times t_{BUS}$	—	ns	
DS2	DSPI_SCK output high/low time	$(t_{SCK}/2) - 2$	$(t_{SCK}/2) + 2$	ns	
DS3	DSPI_PCS _n valid to DSPI_SCK delay	$(t_{BUS} \times 2) - 2$	—	ns	1
DS4	DSPI_SCK to DSPI_PCS _n invalid delay	$(t_{BUS} \times 2) - 2$	—	ns	2
DS5	DSPI_SCK to DSPI_SOUT valid	—	8.5	ns	
DS6	DSPI_SCK to DSPI_SOUT invalid	-2	—	ns	
DS7	DSPI_SIN to DSPI_SCK input setup	16.2	—	ns	
DS8	DSPI_SCK to DSPI_SIN input hold	0	—	ns	

1. The delay is programmable in SPIx_CTARn[PSSCK] and SPIx_CTARn[CSSCK].
2. The delay is programmable in SPIx_CTARn[PASC] and SPIx_CTARn[ASC].

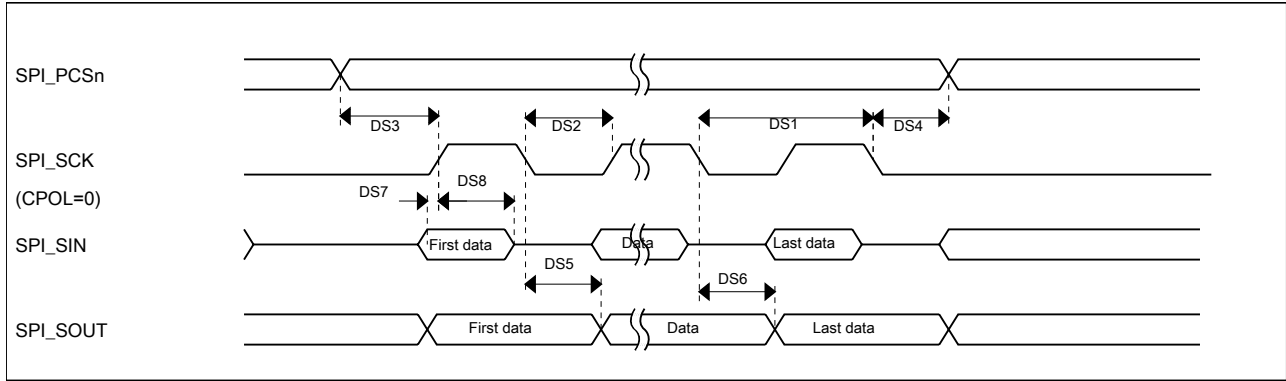

Figure 31. DSPI classic SPI timing — master mode

Table 71. Slave mode DSPI timing (limited voltage range)

Num	Description	Min.	Max.	Unit	Notes
	Operating voltage	2.7	3.6	V	
	Frequency of operation	—	15	MHz	1
DS9	DSPI_SCK input cycle time	$4 \times t_{BUS}$	—	ns	
DS10	DSPI_SCK input high/low time	$(t_{SCK}/2) - 2$	$(t_{SCK}/2) + 2$	ns	
DS11	DSPI_SCK to DSPI_SOUT valid	—	21.4	ns	
DS12	DSPI_SCK to DSPI_SOUT invalid	0	—	ns	
DS13	DSPI_SIN to DSPI_SCK input setup	2.6	—	ns	
DS14	DSPI_SCK to DSPI_SIN input hold	7	—	ns	
DS15	$\overline{DSPI_SS}$ active to DSPI_SOUT driven	—	17	ns	
DS16	$\overline{DSPI_SS}$ inactive to DSPI_SOUT not driven	—	17	ns	

1. The maximum operating frequency is measured with noncontinuous CS and SCK. When DSPI is configured with continuous CS and SCK, the SPI clock must not be greater than 1/6 of the bus clock. For example, when the bus clock is 60 MHz, the SPI clock must not be greater than 10 MHz.

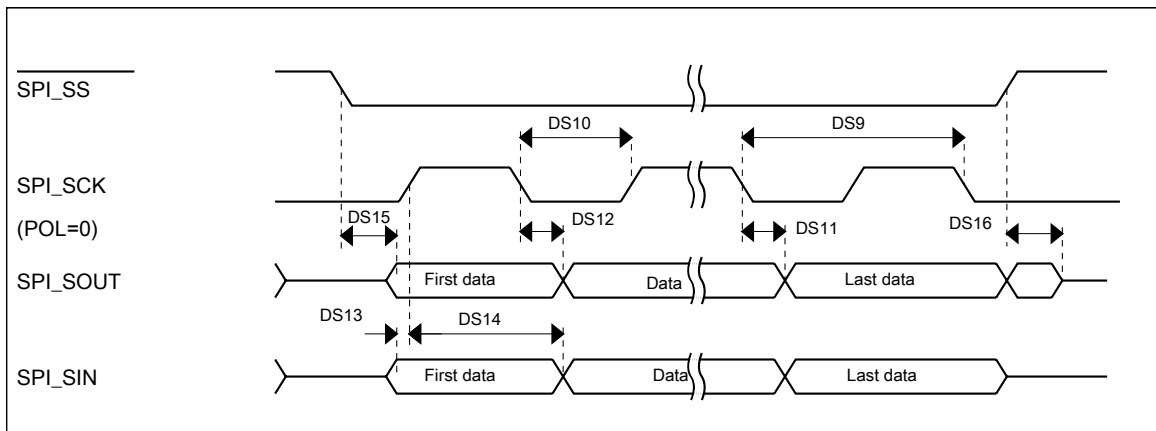

Figure 32. DSPI classic SPI timing — slave mode

5.4.8.3 DSPI switching specifications (full voltage range)

The Deserial Serial Peripheral Interface (DSPI) provides a synchronous serial bus with master and slave operations. Many of the transfer attributes are programmable. The tables below provides DSPI timing characteristics for classic SPI timing modes. Refer to the SPI chapter of the Reference Manual for information on the modified transfer formats used for communicating with slower peripheral devices.

Table 72. Master mode DSPI timing (full voltage range)

Num	Description	Min.	Max.	Unit	Notes
	Operating voltage	1.71	3.6	V	1
	Frequency of operation	—	15	MHz	
DS1	DSPI_SCK output cycle time	$4 \times t_{BUS}$	—	ns	
DS2	DSPI_SCK output high/low time	$(t_{SCK/2}) - 4$	$(t_{SCK/2}) + 4$	ns	
DS3	DSPI_PCSn valid to DSPI_SCK delay	$(t_{BUS} \times 2) - 4$	—	ns	2
DS4	DSPI_SCK to DSPI_PCSn invalid delay	$(t_{BUS} \times 2) - 4$	—	ns	3
DS5	DSPI_SCK to DSPI_SOUT valid	—	10	ns	
DS6	DSPI_SCK to DSPI_SOUT invalid	-4.5	—	ns	
DS7	DSPI_SIN to DSPI_SCK input setup	24.6	—	ns	
DS8	DSPI_SCK to DSPI_SIN input hold	0	—	ns	

1. The DSPI module can operate across the entire operating voltage for the processor, but to run across the full voltage range the maximum frequency of operation is reduced.
2. The delay is programmable in SPIx_CTARn[PSSCK] and SPIx_CTARn[CSSCK].
3. The delay is programmable in SPIx_CTARn[PASC] and SPIx_CTARn[ASC].

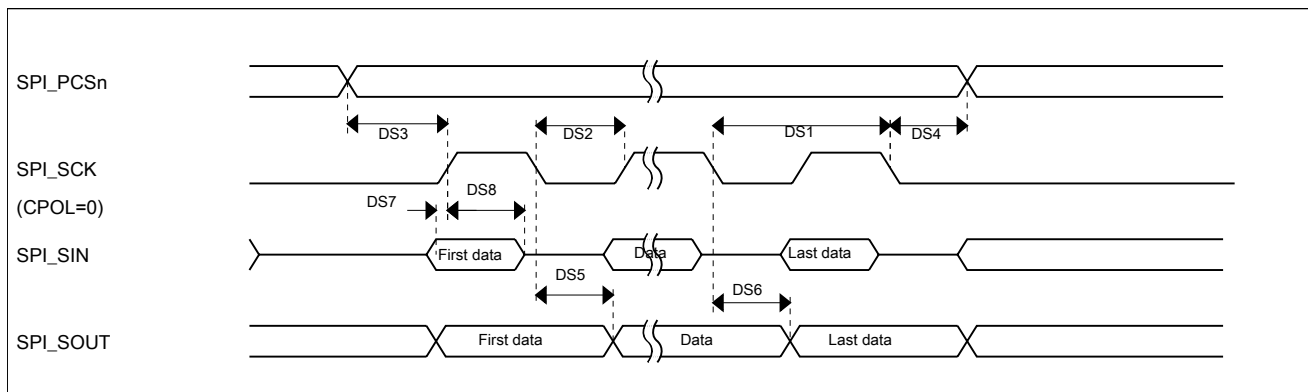
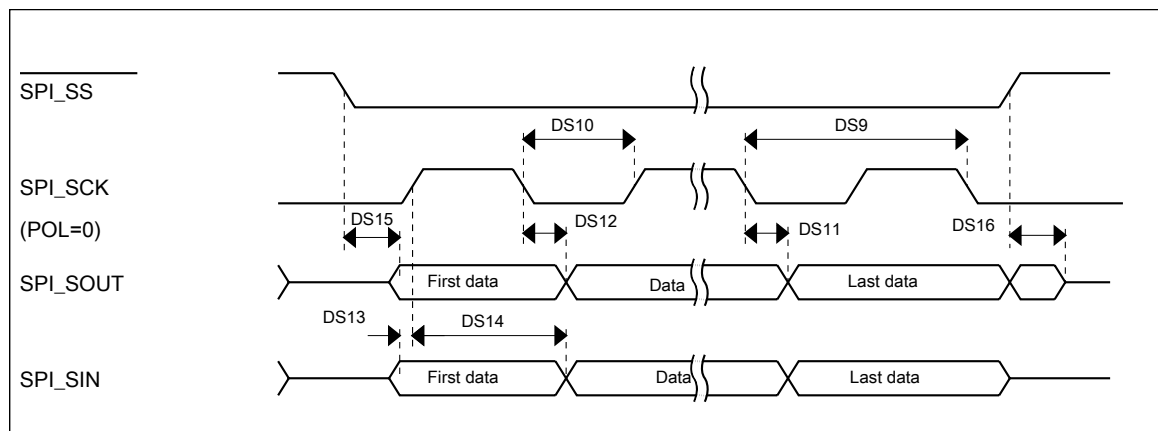

Figure 33. DSPI classic SPI timing — master mode

Table 73. Slave mode DSPI timing (full voltage range)

Num	Description	Min.	Max.	Unit
	Operating voltage	1.71	3.6	V
	Frequency of operation	—	7.5	MHz
DS9	DSPI_SCK input cycle time	$8 \times t_{\text{BUS}}$	—	ns
DS10	DSPI_SCK input high/low time	$(t_{\text{SCK}}/2) - 4$	$(t_{\text{SCK}}/2) + 4$	ns
DS11	DSPI_SCK to DSPI_SOUT valid	—	29.5	ns
DS12	DSPI_SCK to DSPI_SOUT invalid	0	—	ns
DS13	DSPI_SIN to DSPI_SCK input setup	3.2	—	ns
DS14	DSPI_SCK to DSPI_SIN input hold	7	—	ns
DS15	$\overline{\text{DSPI_SS}}$ active to DSPI_SOUT driven	—	25	ns
DS16	$\overline{\text{DSPI_SS}}$ inactive to DSPI_SOUT not driven	—	25	ns

**Figure 34. DSPI classic SPI timing — slave mode**

5.4.8.4 LPI²C

Table 74. LPI²C specifications

Symbol	Description		Min.	Max.	Unit	Notes
f _{SCL}	SCL clock frequency	Standard mode (Sm)	0	100	kHz	1
		Fast mode (Fm)	0	400		1, 2
		Fast mode Plus (Fm+)	0	1000		1, 3
		Ultra Fast mode (UFm)	0	5000		1, 4
		High speed mode (Hs-mode)	0	3400		1, 5

1. See [General switching specifications](#), measured at room temperature.
2. Measured with the maximum bus loading of 400pF at 3.3V VDD with pull-up $R_p = 220\Omega$, and at 1.8V VDD with $R_p = 880\Omega$. For all other cases, select appropriate R_p per I2C Bus Specification and the pin drive capability.
3. Fm+ is only supported on high drive pin with high drive enabled. It is measured with the maximum bus loading of 400pF at 3.3V VDD with $R_p = 220\Omega$. For all other cases, select appropriate R_p per I2C Bus Specification and the pin drive capability.

Electrical characteristics

- UFm is only supported on high drive pin with high drive enabled and push-pull output only mode. It is measured at 3.3V VDD with the maximum bus loading of 400pF. For 1.8V VDD, the maximum speed is 4Mbps.
- Hs-mode is only supported in slave mode and on the high drive pins with high drive enabled.

5.4.8.5 UART switching specifications

See [General switching specifications](#).

5.4.8.6 I2S/SAI switching specifications

This section provides the AC timing for the I2S/SAI module in master mode (clocks are driven) and slave mode (clocks are input). All timing is given for noninverted serial clock polarity (TCR2[BCP] is 0, RCR2[BCP] is 0) and a noninverted frame sync (TCR4[FSP] is 0, RCR4[FSP] is 0). If the polarity of the clock and/or the frame sync have been inverted, all the timing remains valid by inverting the bit clock signal (BCLK) and/or the frame sync (FS) signal shown in the following figures.

5.4.8.6.1 Normal Run, Wait and Stop mode performance over a limited operating voltage range

This section provides the operating performance over a limited operating voltage for the device in Normal Run, Wait and Stop modes.

Table 75. I2S/SAI master mode timing in Normal Run, Wait and Stop modes (limited voltage range)

Num.	Characteristic	Min.	Max.	Unit
	Operating voltage	2.7	3.6	V
S1	I2S_MCLK cycle time	40	—	ns
S2	I2S_MCLK pulse width high/low	45%	55%	MCLK period
S3	I2S_TX_BCLK/I2S_RX_BCLK cycle time (output)	80	—	ns
S4	I2S_TX_BCLK/I2S_RX_BCLK pulse width high/low	45%	55%	BCLK period
S5	I2S_TX_BCLK/I2S_RX_BCLK to I2S_TX_FS/ I2S_RX_FS output valid	—	15	ns
S6	I2S_TX_BCLK/I2S_RX_BCLK to I2S_TX_FS/ I2S_RX_FS output invalid	0	—	ns
S7	I2S_TX_BCLK to I2S_TXD valid	—	15	ns
S8	I2S_TX_BCLK to I2S_TXD invalid	0	—	ns
S9	I2S_RXD/I2S_RX_FS input setup before I2S_RX_BCLK	18	—	ns
S10	I2S_RXD/I2S_RX_FS input hold after I2S_RX_BCLK	0	—	ns

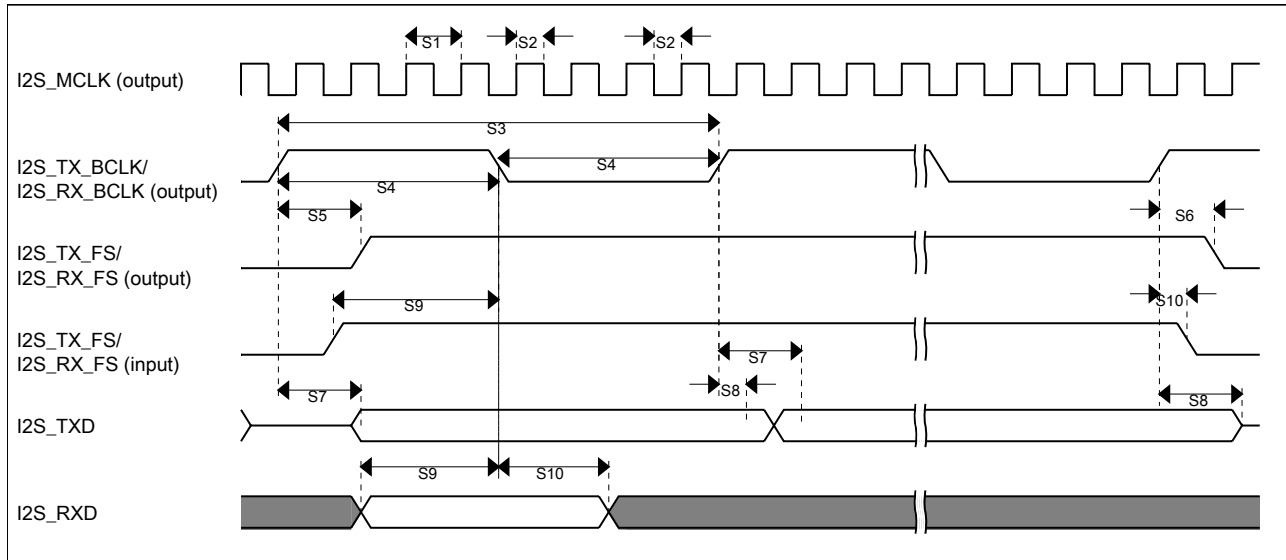

Figure 35. I2S/SAI timing — master modes

Table 76. I2S/SAI slave mode timing in Normal Run, Wait and Stop modes (limited voltage range)

Num.	Characteristic	Min.	Max.	Unit
	Operating voltage	2.7	3.6	V
S11	I2S_TX_BCLK/I2S_RX_BCLK cycle time (input)	80	—	ns
S12	I2S_TX_BCLK/I2S_RX_BCLK pulse width high/low (input)	45%	55%	MCLK period
S13	I2S_TX_FS/I2S_RX_FS input setup before I2S_TX_BCLK/I2S_RX_BCLK	4.5	—	ns
S14	I2S_TX_FS/I2S_RX_FS input hold after I2S_TX_BCLK/I2S_RX_BCLK	2	—	ns
S15	I2S_TX_BCLK to I2S_TXD/I2S_TX_FS output valid	—	20	ns
S16	I2S_TX_BCLK to I2S_TXD/I2S_TX_FS output invalid	0	—	ns
S17	I2S_RXD setup before I2S_RX_BCLK	4.5	—	ns
S18	I2S_RXD hold after I2S_RX_BCLK	2	—	ns
S19	I2S_TX_FS input assertion to I2S_TXD output valid ¹	—	25	ns

1. Applies to first bit in each frame and only if the TCR4[FSE] bit is clear

Electrical characteristics

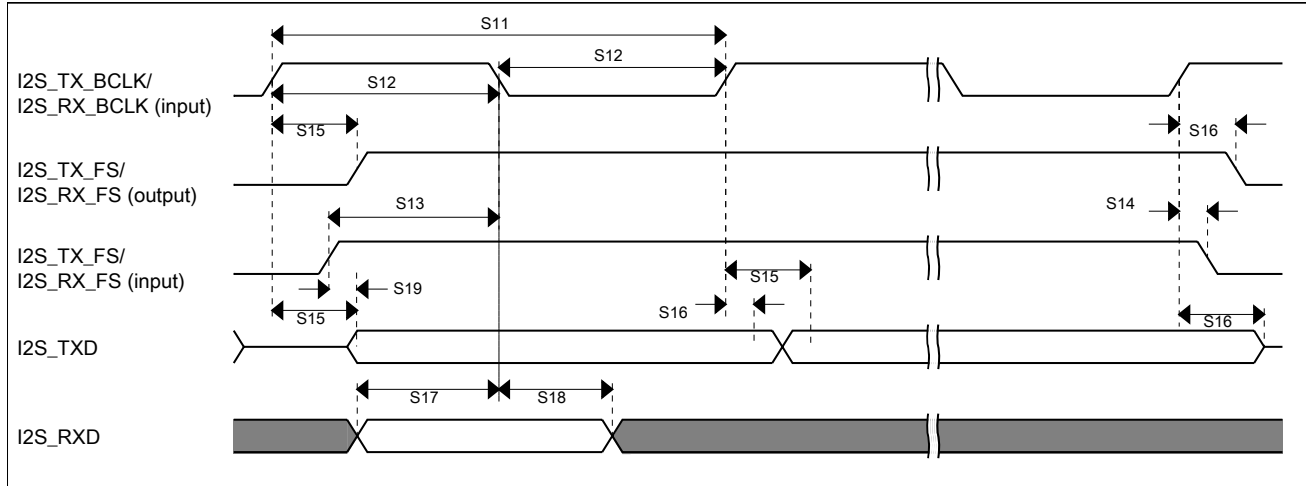

Figure 36. I2S/SAI timing — slave modes

5.4.8.6.2 Normal Run, Wait and Stop mode performance over the full operating voltage range

This section provides the operating performance over the full operating voltage for the device in Normal Run, Wait and Stop modes.

Table 77. I2S/SAI master mode timing in Normal Run, Wait and Stop modes (full voltage range)

Num.	Characteristic	Min.	Max.	Unit
	Operating voltage	1.71	3.6	V
S1	I2S_MCLK cycle time	40	—	ns
S2	I2S_MCLK pulse width high/low	45%	55%	MCLK period
S3	I2S_TX_BCLK/I2S_RX_BCLK cycle time (output)	80	—	ns
S4	I2S_TX_BCLK/I2S_RX_BCLK pulse width high/low	45%	55%	BCLK period
S5	I2S_TX_BCLK/I2S_RX_BCLK to I2S_TX_FS/ I2S_RX_FS output valid	—	15	ns
S6	I2S_TX_BCLK/I2S_RX_BCLK to I2S_TX_FS/ I2S_RX_FS output invalid	-1.0	—	ns
S7	I2S_TX_BCLK to I2S_TXD valid	—	15	ns
S8	I2S_TX_BCLK to I2S_TXD invalid	0	—	ns
S9	I2S_RXD/I2S_RX_FS input setup before I2S_RX_BCLK	27	—	ns
S10	I2S_RXD/I2S_RX_FS input hold after I2S_RX_BCLK	0	—	ns

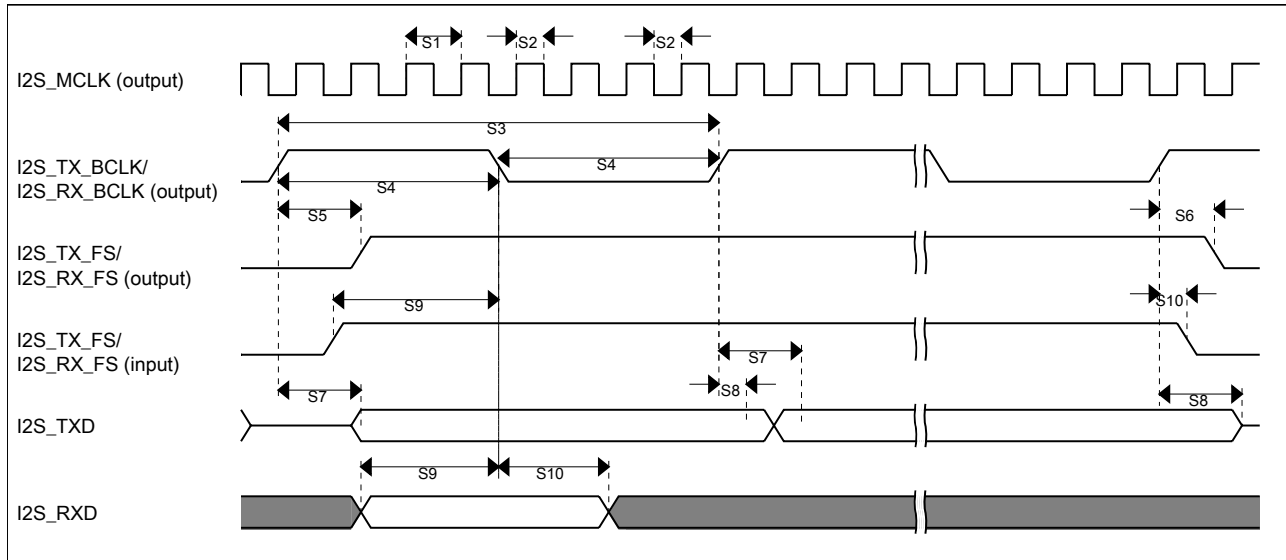

Figure 37. I2S/SAI timing — master modes

Table 78. I2S/SAI slave mode timing in Normal Run, Wait and Stop modes (full voltage range)

Num.	Characteristic	Min.	Max.	Unit
	Operating voltage	1.71	3.6	V
S11	I2S_TX_BCLK/I2S_RX_BCLK cycle time (input)	80	—	ns
S12	I2S_TX_BCLK/I2S_RX_BCLK pulse width high/low (input)	45%	55%	MCLK period
S13	I2S_TX_FS/I2S_RX_FS input setup before I2S_TX_BCLK/I2S_RX_BCLK	5.8	—	ns
S14	I2S_TX_FS/I2S_RX_FS input hold after I2S_TX_BCLK/I2S_RX_BCLK	2	—	ns
S15	I2S_TX_BCLK to I2S_TXD/I2S_TX_FS output valid	—	28.5	ns
S16	I2S_TX_BCLK to I2S_TXD/I2S_TX_FS output invalid	0	—	ns
S17	I2S_RXD setup before I2S_RX_BCLK	5.8	—	ns
S18	I2S_RXD hold after I2S_RX_BCLK	2	—	ns
S19	I2S_TX_FS input assertion to I2S_TXD output valid ¹	—	26.3	ns

1. Applies to first bit in each frame and only if the TCR4[FSE] bit is clear

Electrical characteristics

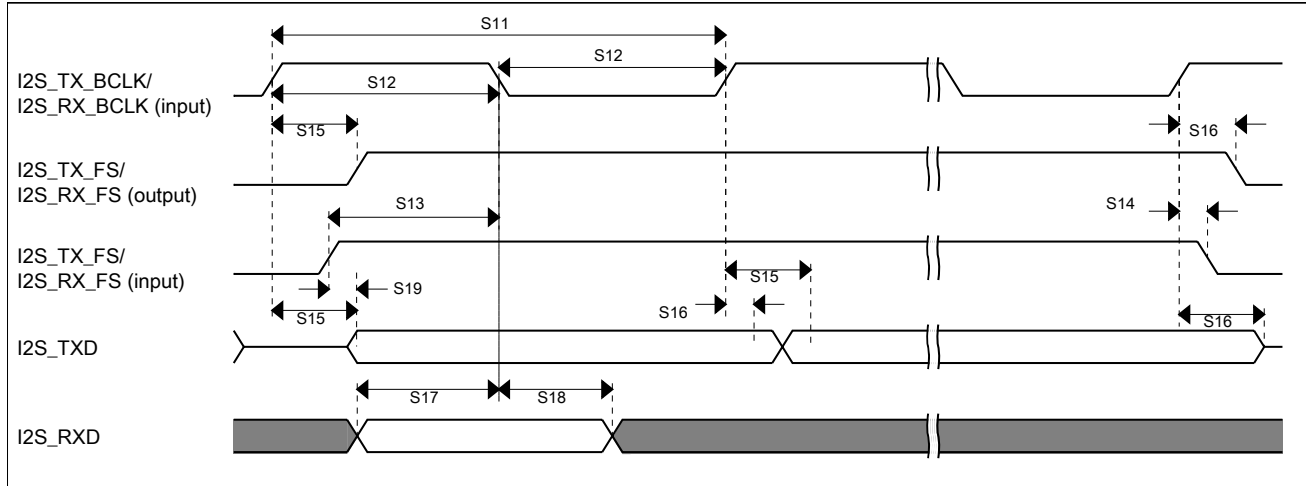

Figure 38. I2S/SAI timing — slave modes

5.4.8.6.3 VLPR, VLPW, and VLPS mode performance over the full operating voltage range

This section provides the operating performance over the full operating voltage for the device in VLPR, VLPW, and VLPS modes.

Table 79. I2S/SAI master mode timing in VLPR, VLPW, and VLPS modes (full voltage range)

Num.	Characteristic	Min.	Max.	Unit
	Operating voltage	1.71	3.6	V
S1	I2S_MCLK cycle time	62.5	—	ns
S2	I2S_MCLK pulse width high/low	45%	55%	MCLK period
S3	I2S_TX_BCLK/I2S_RX_BCLK cycle time (output)	250	—	ns
S4	I2S_TX_BCLK/I2S_RX_BCLK pulse width high/low	45%	55%	BCLK period
S5	I2S_TX_BCLK/I2S_RX_BCLK to I2S_TX_FS/ I2S_RX_FS output valid	—	45	ns
S6	I2S_TX_BCLK/I2S_RX_BCLK to I2S_TX_FS/ I2S_RX_FS output invalid	-1	—	ns
S7	I2S_TX_BCLK to I2S_TXD valid	—	45	ns
S8	I2S_TX_BCLK to I2S_TXD invalid		—	ns
S9	I2S_RXD/I2S_RX_FS input setup before I2S_RX_BCLK		—	ns
S10	I2S_RXD/I2S_RX_FS input hold after I2S_RX_BCLK	0	—	ns

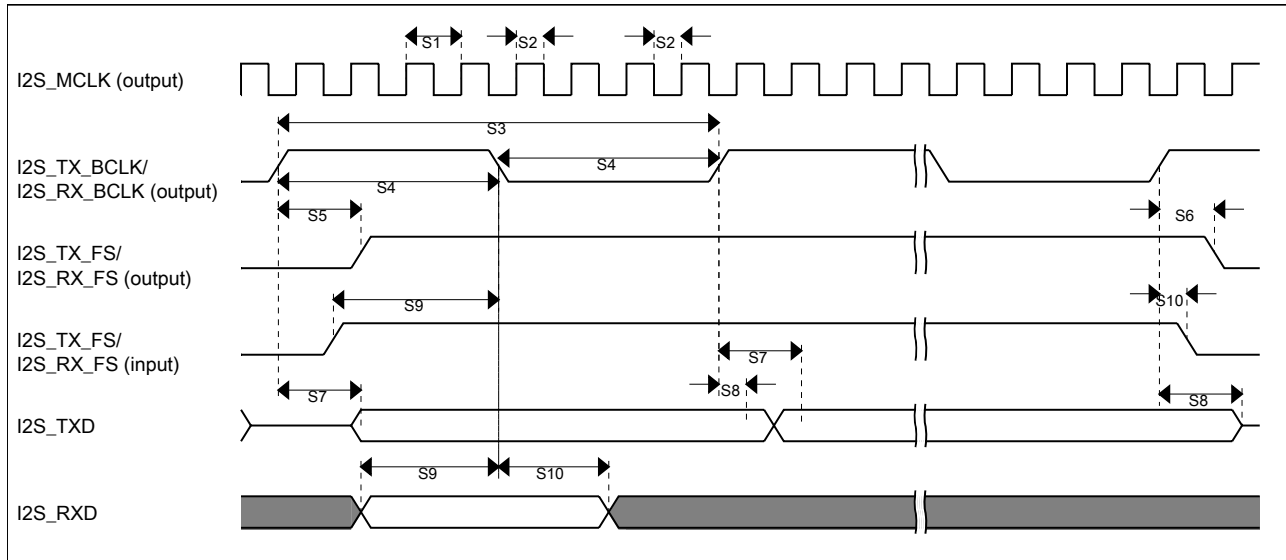

Figure 39. I2S/SAI timing — master modes

Table 80. I2S/SAI slave mode timing in VLPR, VLPW, and VLPS modes (full voltage range)

Num.	Characteristic	Min.	Max.	Unit
	Operating voltage	1.71	3.6	V
S11	I2S_TX_BCLK/I2S_RX_BCLK cycle time (input)	250	—	ns
S12	I2S_TX_BCLK/I2S_RX_BCLK pulse width high/low (input)	45%	55%	MCLK period
S13	I2S_TX_FS/I2S_RX_FS input setup before I2S_TX_BCLK/I2S_RX_BCLK	30	—	ns
S14	I2S_TX_FS/I2S_RX_FS input hold after I2S_TX_BCLK/I2S_RX_BCLK	7	—	ns
S15	I2S_TX_BCLK to I2S_TXD/I2S_TX_FS output valid	—	—	ns
S16	I2S_TX_BCLK to I2S_TXD/I2S_TX_FS output invalid	0	—	ns
S17	I2S_RXD setup before I2S_RX_BCLK	30	—	ns
S18	I2S_RXD hold after I2S_RX_BCLK	4	—	ns
S19	I2S_TX_FS input assertion to I2S_TXD output valid ¹	—	72	ns

1. Applies to first bit in each frame and only if the TCR4[FSE] bit is clear

Design considerations

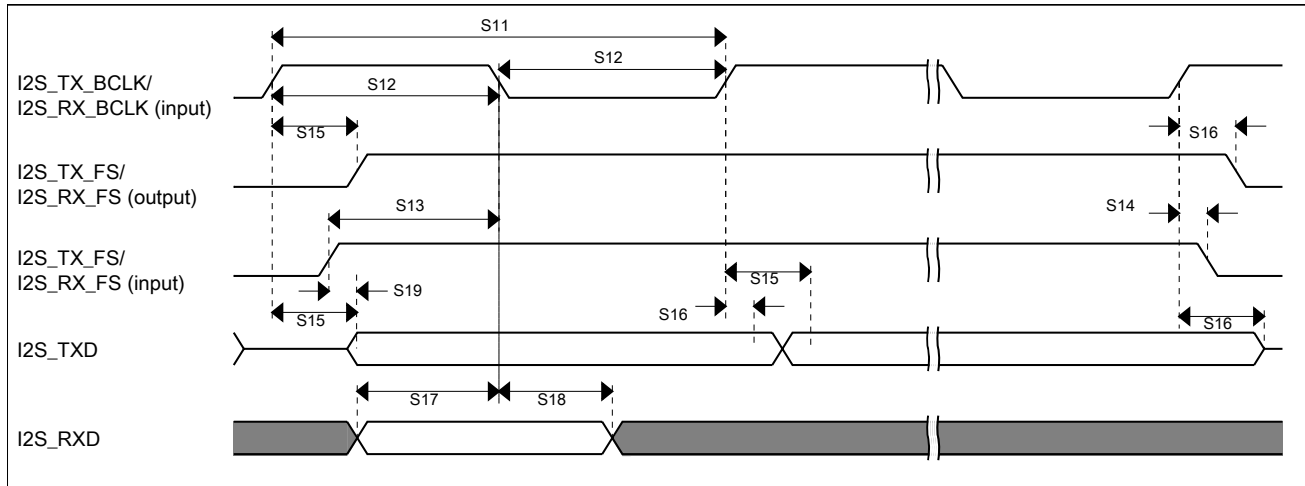

Figure 40. I2S/SAI timing — slave modes

6 Design considerations

6.1 Hardware design considerations

This device contains protective circuitry to guard against damage due to high static voltage or electric fields. However, take normal precautions to avoid application of any voltages higher than maximum-rated voltages to this high-impedance circuit.

6.1.1 Printed circuit board recommendations

- Place connectors or cables on one edge of the board and do not place digital circuits between connectors.
- Drivers and filters for I/O functions must be placed as close to the connectors as possible. Connect TVS devices at the connector to a good ground. Connect filter capacitors at the connector to a good ground. Consider to add ferrite bead or inductor to some sensitive lines.
- Physically isolate analog circuits from digital circuits if possible.
- Place input filter capacitors as close to the MCU as possible.
- For best EMC performance, route signals as transmission lines; use a ground plane directly under LQFP packages; and solder the exposed pad (EP) to ground directly under QFN packages.

6.1.2 Power delivery system

Consider the following items in the power delivery system:

- Use a plane for ground.
- Use a plane for MCU VDD supply if possible.
- Always route ground first, as a plane or continuous surface, and never as sequential segments.
- Always route the power net as star topology, and make each power trace loop as minimum as possible.
- Route power next, as a plane or traces that are parallel to ground traces.
- Place bulk capacitance, 10 μF or more, at the entrance of the power plane.
- Place bypass capacitors for MCU power domain as close as possible to each VDD/VSS pair, including VDDA/VSSA and VREFH/VREFL.
- The minimum bypass requirement is to place 0.1 μF capacitors positioned as near as possible to the package supply pins.
- The USB_VDD voltage range is 3.0 V to 3.6 V. It is recommended to include a filter circuit with one bulk capacitor (no less than 2.2 μF) and one 0.1 μF capacitor at the USB_VDD pin to improve USB performance.

6.1.3 Analog design

Each ADC input must have an RC filter as shown in the following figure. The maximum value of R must be $R_{AS\ max}$ if fast sampling and high resolution are required. The value of C must be chosen to ensure that the RC time constant is very small compared to the sample period.

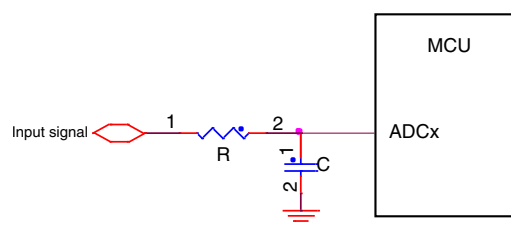

Figure 41. RC circuit for ADC input

High voltage measurement circuits require voltage division, current limiting, and over-voltage protection as shown the following figure. The voltage divider formed by R1 – R4 must yield a voltage less than or equal to VREFH. The current must be limited to less than the injection current limit. Since the ADC pins do not have diodes to VDD, external clamp diodes must be included to protect against transient over-voltages.

Design considerations

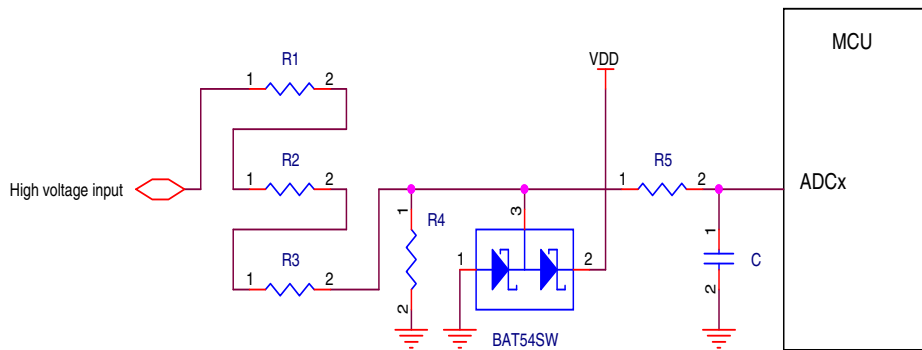

Figure 42. High voltage measurement with an ADC input

NOTE

For more details of ADC related usage, refer to [AN5250: How to Increase the Analog-to-Digital Converter Accuracy in an Application](#).

6.1.4 Digital design

Ensure that all I/O pins cannot get pulled above VDD (Max I/O is $VDD+0.3V$).

CAUTION

Do not provide power to I/O pins prior to VDD, especially the RESET_b pin.

- RESET_b pin

The RESET_b pin is an open-drain I/O pin that has an internal pullup resistor. An external RC circuit is recommended to filter noise as shown in the following figure. The resistor value must be in the range of 4.7 k Ω to 10 k Ω ; the recommended capacitance value is 0.1 μ F. The RESET_b pin also has a selectable digital filter to reject spurious noise.

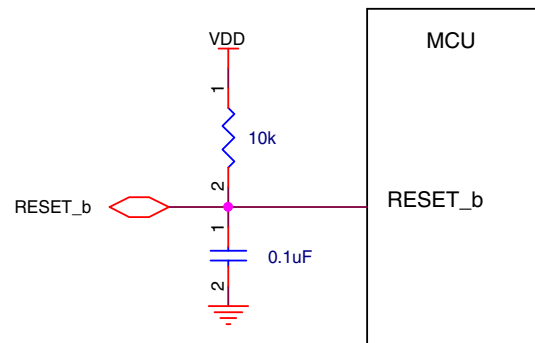

Figure 43. Reset circuit

When an external supervisor chip is connected to the RESET_b pin, a series resistor must be used to avoid damaging the supervisor chip or the RESET_b pin, as shown in the following figure. The series resistor value (R_S below) must be in the range of $100\ \Omega$ to $1\ \text{k}\Omega$ depending on the external reset chip drive strength. The supervisor chip must have an active high, open-drain output.

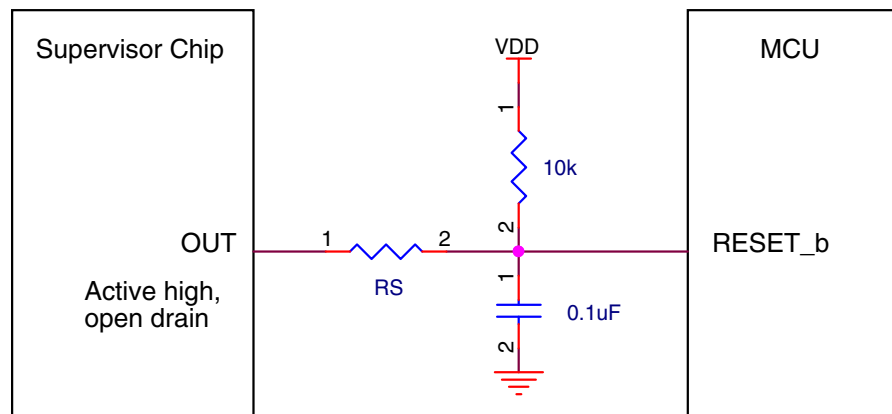

Figure 44. Reset signal connection to external reset chip

- NMI pin

Do not add a pull-down resistor or capacitor on the NMI_b pin, because a low level on this pin will trigger non-maskable interrupt. When this pin is enabled as the NMI function, an external pull-up resistor ($10\ \text{k}\Omega$) as shown in the following figure is recommended for robustness.

If the NMI_b pin is used as an I/O pin, the non-maskable interrupt handler is required to disable the NMI function by remapping to another function. The NMI function is disabled by programming the FOPT[NMI_DIS] bit to zero.

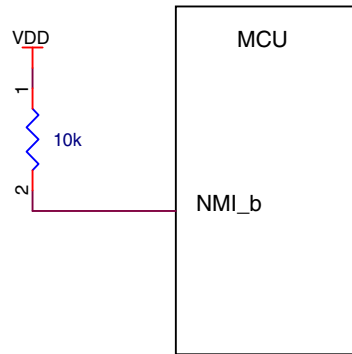

Figure 45. NMI pin biasing

- Debug interface

This MCU uses the standard ARM SWD interface protocol as shown in the following figure. While pull-up or pull-down resistors are not required (SWD_DIO has an internal pull-up and SWD_CLK has an internal pull-down), external 10 kΩ pull resistors are recommended for system robustness. The RESET_b pin recommendations mentioned above must also be considered.

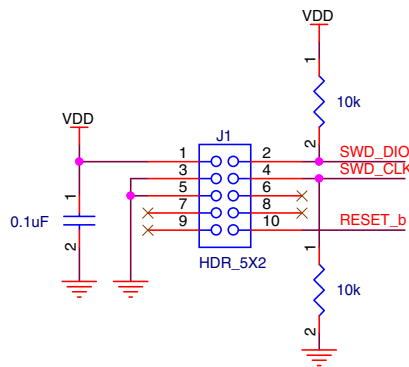

Figure 46. SWD debug interface

- Low leakage stop mode wakeup

Select low leakage wakeup pins (LLWU_Px) to wake the MCU from one of the low leakage stop modes (LLS/VLLSx). See the pinout table for pin selection.

- Unused pin

Unused GPIO pins must be left floating (no electrical connections) with the MUX field of the pin's PORTx_PCRn register equal to 0:0:0. This disables the digital input path to the MCU.

If the USB module is not used, leave the USB data pins (USB0_DP, USB0_DM) floating. Connect USB_VDD to ground through a 10 k Ω resistor if the USB module is not used.

6.1.5 Crystal oscillator

When using an external crystal or ceramic resonator as the frequency reference for the MCU clock system, refer to the following table and diagrams.

The feedback resistor, RF, is incorporated internally with the low power oscillators. An external feedback is required when using high gain (HGO=1) mode.

Internal load capacitors (Cx, Cy) are provided in the low frequency (32.786 kHz) mode. Use the SCxP bits in the OSC0_CR register to adjust the load capacitance for the crystal. Typically, values of 10pF to 16 pF are sufficient for 32.768 kHz crystals that have a 12.5 pF CL specification. The internal load capacitor selection must not be used for high frequency crystals and resonators.

Table 81. External crystal/resonator connections

Oscillator mode	Oscillator mode
Low frequency (32.768 kHz), low power	Diagram 1
Low frequency (32.768 kHz), high gain	Diagram 2, Diagram 4
High frequency (3-32 MHz), low power	Diagram 3
High frequency (3-32 MHz), high gain	Diagram 4

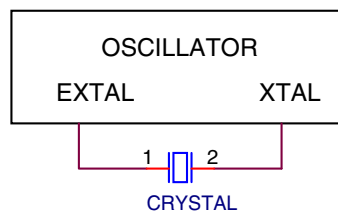

Figure 47. Crystal connection – Diagram 1

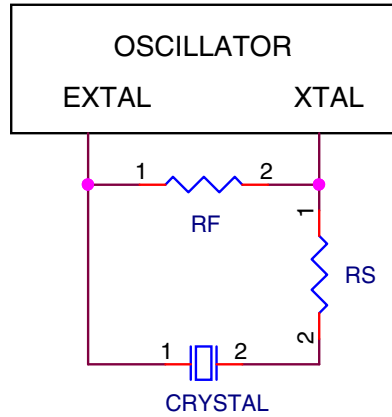

Figure 48. Crystal connection – Diagram 2

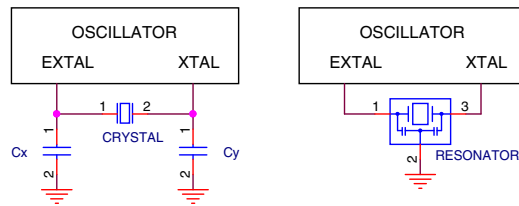

Figure 49. Crystal connection – Diagram 3

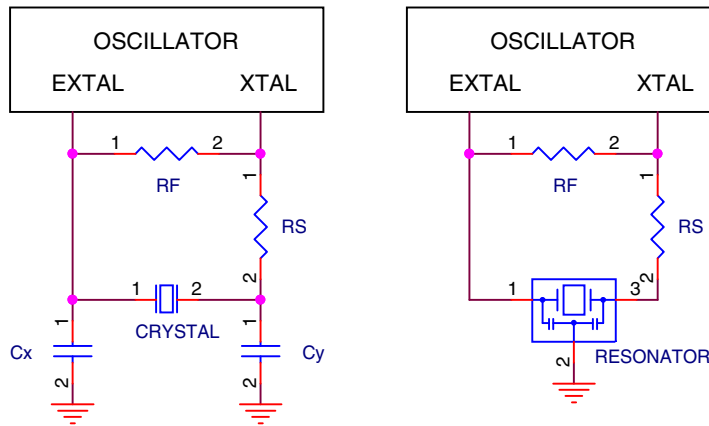

Figure 50. Crystal connection – Diagram 4

6.2 Software considerations

All Kinetis MCUs are supported by comprehensive NXP and third-party hardware and software enablement solutions, which can reduce development costs and time to market. Featured software and tools are listed below. Visit <http://www.nxp.com/kinetis/sw> for more information and supporting collateral.

Evaluation and Prototyping Hardware

- MAPS Development Kit: <http://www.nxp.com/KS>

IDEs for Kinetis MCUs

- Kinetis Design Studio IDE: <http://www.nxp.com/kds>
- Partner IDEs: <http://www.nxp.com/kide>

Run-time Software

- Kinetis SDK: <http://www.nxp.com/ksdk>
- Kinetis Bootloader: <http://www.nxp.com/kboot>
- ARM mbed Development Platform: <http://www.nxp.com/mbed>

For all other partner-developed software and tools, visit <http://www.nxp.com/partners>.

7 Part identification

7.1 Description

Part numbers for the chip have fields that identify the specific part. You can use the values of these fields to determine the specific part you have received.

7.2 Format

Part numbers for this device have the following format:

Q KS## A FFF R T PP CC N

7.3 Fields

This table lists the possible values for each field in the part number (not all combinations are valid):

Table 82. Part number fields description

Field	Description	Values
Q	Qualification status	<ul style="list-style-type: none"> • M = Fully qualified, general market flow • P = Prequalification
KS##	Kinetis family	<ul style="list-style-type: none"> • KS20 • KS22

Table continues on the next page...

Table 82. Part number fields description (continued)

Field	Description	Values
A	Key attribute	<ul style="list-style-type: none"> F = Cortex-M4 with DSP and FPU
FFF	Program flash memory size	<ul style="list-style-type: none"> 128 = 128 KB 256 = 256 KB
R	Silicon revision	<ul style="list-style-type: none"> (Blank) = Main A = Revision after main
T	Temperature range (°C)	<ul style="list-style-type: none"> V = -40 to 105
PP	Package identifier	<ul style="list-style-type: none"> FT = 48 QFN (7 mm x 7 mm) LH = 64 LQFP (10 mm x 10 mm) LL = 100 LQFP (14 mm x 14 mm)
CC	Maximum CPU frequency (MHz)	<ul style="list-style-type: none"> 12 = 120 MHz
N	Packaging type	<ul style="list-style-type: none"> R = Tape and reel (Blank) = Trays

7.4 Example

This is an example part number:

MKS22FN256VLL12

8 Revision history

The following table provides a revision history for this document.

Table 83. Revision history

Rev. No.	Date	Substantial Changes
2	12/2015	Initial public release.
3	04/2016	Added 48-pin QFN package.
3.1	06/2022	<ul style="list-style-type: none"> Updated the USB descriptions, in "Communication interfaces" section of the front matter feature list, and "USB" sub-section of the "Peripheral features" section. Minor correction in the "Pin properties" table: pin number 8-11 rows for 48QFN.

How to Reach Us:**Home Page:**nxp.com**Web Support:**nxp.com/support

Limited warranty and liability — Information in this document is believed to be accurate and reliable. However, NXP Semiconductors does not give any representations or warranties, expressed or implied, as to the accuracy or completeness of such information and shall have no liability for the consequences of use of such information. NXP Semiconductors takes no responsibility for the content in this document if provided by an information source outside of NXP Semiconductors. In no event shall NXP Semiconductors be liable for any indirect, incidental, punitive, special or consequential damages (including - without limitation - lost profits, lost savings, business interruption, costs related to the removal or replacement of any products or rework charges) whether or not such damages are based on tort (including negligence), warranty, breach of contract or any other legal theory.

Notwithstanding any damages that customer might incur for any reason whatsoever, NXP Semiconductors' aggregate and cumulative liability towards customer for the products described herein shall be limited in accordance with the Terms and conditions of commercial sale of NXP Semiconductors.

Right to make changes - NXP Semiconductors reserves the right to make changes to information published in this document, including without limitation specifications and product descriptions, at any time and without notice. This document supersedes and replaces all information supplied prior to the publication hereof.

Security — Customer understands that all NXP products may be subject to unidentified or documented vulnerabilities. Customer is responsible for the design and operation of its applications and products throughout their lifecycles to reduce the effect of these vulnerabilities on customer's applications and products. Customer's responsibility also extends to other open and/or proprietary technologies supported by NXP products for use in customer's applications. NXP accepts no liability for any vulnerability. Customer should regularly check security updates from NXP and follow up appropriately.

Customer shall select products with security features that best meet rules, regulations, and standards of the intended application and make the ultimate design decisions regarding its products and is solely responsible for compliance with all legal, regulatory, and security related requirements concerning its products, regardless of any information or support that may be provided by NXP. NXP has a Product Security Incident Response Team (PSIRT) (reachable at PSIRT@nxp.com) that manages the investigation, reporting, and solution release to security vulnerabilities of NXP products.

Suitability for use — NXP Semiconductors products are not designed, authorized or warranted to be suitable for use in life support, life-critical or safety-critical systems or equipment, nor in applications where failure or malfunction of an NXP Semiconductors product can reasonably be expected to result in personal injury, death or severe property or environmental damage. NXP Semiconductors and its suppliers accept no liability for inclusion and/or use of NXP Semiconductors products in such equipment or applications and therefore such inclusion and/or use is at the customer's own risk.

Non-automotive qualified products — Unless this data sheet expressly states that this specific NXP Semiconductors product is automotive qualified, the product is not suitable for automotive use. It is neither qualified nor tested in accordance with automotive testing or application requirements. NXP Semiconductors accepts no liability for inclusion and/or use of non-automotive qualified products in automotive equipment or applications.

In the event that customer uses the product for design-in and use in automotive applications to automotive specifications and standards, customer (a) shall use the product without NXP Semiconductors' warranty of the product for such automotive applications, use and specifications,

and (b) whenever customer uses the product for automotive applications beyond NXP Semiconductors' specifications such use shall be solely at customer's own risk, and (c) customer fully indemnifies NXP Semiconductors for any liability, damages or failed product claims resulting from customer design and use of the product for automotive applications beyond NXP Semiconductors' standard warranty and NXP Semiconductors' product specifications.

Applications — Applications that are described herein for any of these products are for illustrative purposes only. NXP Semiconductors makes no representation or warranty that such applications will be suitable for the specified use without further testing or modification.

Customers are responsible for the design and operation of their applications and products using NXP Semiconductors products, and NXP Semiconductors accepts no liability for any assistance with applications or customer product design. It is customer's sole responsibility to determine whether the NXP Semiconductors product is suitable and fit for the customer's applications and products planned, as well as for the planned application and use of customer's third party customer(s). Customers should provide appropriate design and operating safeguards to minimize the risks associated with their applications and products.

NXP Semiconductors does not accept any liability related to any default, damage, costs or problem which is based on any weakness or default in the customer's applications or products, or the application or use by customer's third party customer(s). Customer is responsible for doing all necessary testing for the customer's applications and products using NXP Semiconductors products in order to avoid a default of the applications and the products or of the application or use by customer's third party customer(s). NXP does not accept any liability in this respect.

Limiting values — Stress above one or more limiting values (as defined in the Absolute Maximum Ratings System of IEC 60134) will cause permanent damage to the device. Limiting values are stress ratings only and (proper) operation of the device at these or any other conditions above those given in the Recommended operating conditions section (if present) or the Characteristics sections of this document is not warranted. Constant or repeated exposure to limiting values will permanently and irreversibly affect the quality and reliability of the device.

Terms and conditions of commercial sale — NXP Semiconductors products are sold subject to the general terms and conditions of commercial sale, as published at <http://www.nxp.com/profile/terms>, unless otherwise agreed in a valid written individual agreement. In case an individual agreement is concluded only the terms and conditions of the respective agreement shall apply. NXP Semiconductors hereby expressly objects to applying the customer's general terms and conditions with regard to the purchase of NXP Semiconductors products by customer.

No offer to sell or license — Nothing in this document may be interpreted or construed as an offer to sell products that is open for acceptance or the grant, conveyance or implication of any license under any copyrights, patents or other industrial or intellectual property rights.

Quick reference data — The Quick reference data is an extract of the product data given in the Limiting values and Characteristics sections of this document, and as such is not complete, exhaustive or legally binding.

Export control — This document as well as the item(s) described herein may be subject to export control regulations. Export might require a prior authorization from competent authorities.

Translations — A non-English (translated) version of a document is for reference only. The English version shall prevail in case of any discrepancy between the translated and English versions.

NXP, the NXP logo, NXP SECURE CONNECTIONS FOR A SMARTER WORLD, Freescale, the Freescale logo, Kinetic, are trademarks of NXP B.V. All other product or service names are the property of their respective owners. AMBA, Arm, Arm7, Arm7TDMI, Arm9, Arm11, Artisan, big.LITTLE, Cordio, CoreLink, CoreSight, Cortex, DesignStart, DynamIQ, Jazelle, Keil, Mali, Mbed, Mbed Enabled, NEON, POP, RealView, SecurCore, Socrates, Thumb, TrustZone, ULINK, ULINK2, ULINK-ME, ULINK-PLUS, ULINKpro, μ Vision, Versatile are trademarks or registered trademarks of Arm Limited (or its subsidiaries) in the US and/or elsewhere. The related technology may be protected by any or all of patents, copyrights, designs and trade secrets. All rights reserved.

© 2015–2022 NXP B.V.

Document Number KS22P100M120SF0
Revision 3.1, 06/2022



Looking for pricing, stock, or lifecycle information?

Click below to explore more details on WIN SOURCE:

 [View MKS22FN128VLL12 on WIN SOURCE](#)

 [NXP / Nexperia Information](#)

Optimize Your Supply Chain with WIN SOURCE Solutions

-  Global Sourcing Solution
-  Obsolete Management
-  Cost Control Management
-  Shortage Management
-  Alternative Solution
-  Excess Inventory Management