



**THE DATASHEET OF  
MC74LV594ADR2G**



# MC74LV594A

## 8-Bit Shift Register with Output Register

The MC74LV594A is an 8-bit shift register designed for 2 V to 6.0 V  $V_{CC}$  operation. The device contains an 8-bit serial-in, parallel-out shift register that feeds an 8-bit D-type storage register. Separate clocks (RCLK, SRCLK) and direct overriding clear ( $\overline{RCLR}$ ,  $\overline{SRCLR}$ ) inputs are provided on the shift and storage registers. A serial output ( $Q_H$ ) is provided for cascading purposes.

The shift-register (SRCLK) and storage-register (RCLK) clocks are positive-edge triggered. If the clocks are tied together, the shift register always is one clock pulse ahead of the storage register.

### Features

- 2.0 V to 6.0 V  $V_{CC}$  Operation
- Low Input Current: 1.0  $\mu$ A
- Max  $t_{pd}$  of 6.5 ns at 5 V
- Typical  $V_{OLP}$  (Output Ground Bounce) < 0.8 V at  $V_{CC} = 3.3$  V,  $T_A = 25^\circ$ C
- Typical  $V_{OHV}$  (Output  $V_{OH}$  Undershoot) > 2.3 V at  $V_{CC} = 3.3$  V,  $T_A = 25^\circ$ C
- Support Mixed-Mode Voltage Operation on All Ports
- 8-Bit Serial-In, Parallel-Out Shift Registers With Storage
- Independent Direct Overriding Clears on Shift and Storage Registers
- Independent Clocks for Shift and Storage Registers
- High Noise Immunity Characteristic of CMOS Devices
- In Compliance with the Requirements Defined by JEDEC Standard No. 7A
- These Devices are Pb-Free, Halogen Free/BFR Free and are RoHS Compliant



ON Semiconductor®

[www.onsemi.com](http://www.onsemi.com)

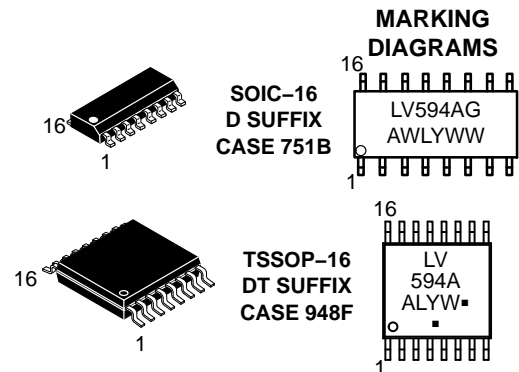

A = Assembly Location  
 WL, L = Wafer Lot  
 YY, Y = Year  
 WW, W = Work Week  
 G or ■ = Pb-Free Package

(Note: Microdot may be in either location)

### PIN ASSIGNMENT

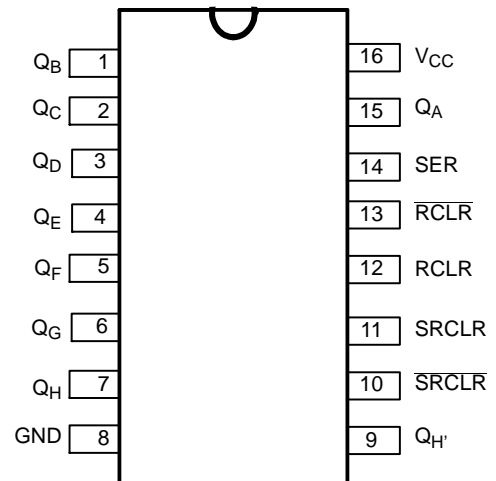

### ORDERING INFORMATION

See detailed ordering and shipping information in the package dimensions section on page 4 of this data sheet.

## MC74LV594A

FUNCTION TABLE

INPUTS					FUNCTION
SER	SRCLK	$\overline{\text{SRCLR}}$	RCLK	$\overline{\text{RCLR}}$	
X	X	L	X	X	Shift register is cleared.
L	↑	H	X	X	First stage of shift register goes low. Other stages store the data of previous stage, respectively.
H	↑	H	X	X	First stage of shift register goes high. Other stages store the data of previous stage, respectively.
L	↓	H	X	X	Shift register state is not changed.
X	X	X	X	L	Storage register is cleared.
X	X	X	↑	H	Shift register data is stored in the storage register.
X	X	X	↓	H	Storage register state is not changed.



# MC74LV594A

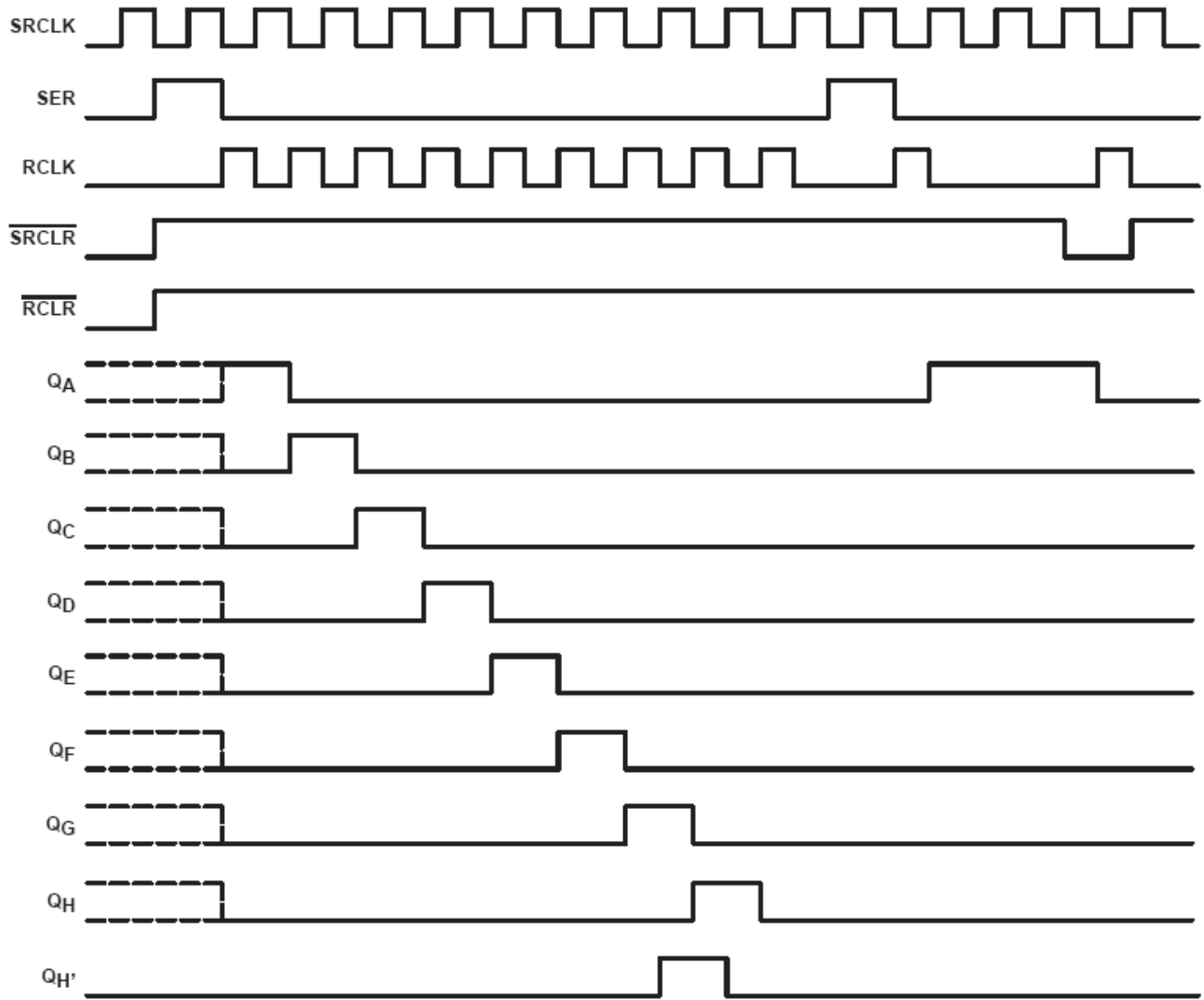

Figure 2. Timing Diagram

## ORDERING INFORMATION

Device	Package	Shipping†
MC74LV594ADR2G	SOIC-16 (Pb-Free)	2500 / Tape & Reel
MC74LV594ADTR2G	TSSOP-16 (Pb-Free)	2500 / Tape & Reel

†For information on tape and reel specifications, including part orientation and tape sizes, please refer to our Tape and Reel Packaging Specifications Brochure, BRD8011/D.

# MC74LV594A

## MAXIMUM RATINGS

Symbol	Parameter	Value	Unit
$V_{CC}$	DC Supply Voltage	-0.5 to +7.0	V
$V_I$	DC Input Voltage	-0.5 to $V_{CC} + 0.5$	V
$V_O$	DC Output Voltage Active Mode (Note 1)	-0.5 to $V_{CC} + 0.5$	V
	High Impedance or Power-Off Mode	-0.5 to +7.0	
$I_{IK}$	DC Input Clamp Current	$\pm 20$	mA
$I_{OK}$	DC Output Clamp Current	$\pm 35$	mA
$I_{IN}$	DC Input Current	$\pm 20$	mA
$I_O$	DC Output Source / Sink Current	$\pm 35$	mA
$I_{CC}$	DC Supply Current per Supply Pin	$\pm 75$	mA
$I_{GND}$	DC Ground Current per Ground Pin	$\pm 75$	mA
$T_{STG}$	Storage Temperature Range	-65 to +150	$^{\circ}C$
$T_L$	Lead temperature, 1 mm from Case for 10 Seconds	260	$^{\circ}C$
$T_J$	Junction temperature under Bias	+150	$^{\circ}C$
$\theta_{JA}$	Thermal Resistance SOIC TSSOP	112 148	$^{\circ}C$
$P_D$	Power Dissipation in Still Air at SOIC TSSOP	500 450	mW
MSL	Moisture Sensitivity	Level 1	
$F_R$	Flammability Rating Oxygen Index: 30% – 35%	UL-94-V0 (0.125 in)	
$V_{ESD}$	ESD Withstand Voltage Human Body Model (Note 2) Machine Model (Note 3) Charged Device Model (Note 4)	> 3000 >400 N/A	V
$I_{Latchup}$	Latchup Performance Above $V_{CC}$ and Below GND at 85 $^{\circ}C$ (Note 5)	$\pm 300$	mA

Stresses exceeding those listed in the Maximum Ratings table may damage the device. If any of these limits are exceeded, device functionality should not be assumed, damage may occur and reliability may be affected.

1.  $I_O$  absolute maximum rating must be observed.
2. Tested to EIA/JESD22-A114-A.
3. Tested to EIA/JESD22-A115-A.
4. Tested to JESD22-C101-A.
5. Tested to EIA/JESD78.

## RECOMMENDED OPERATING CONDITIONS (Note 6)

Symbol	Parameter	Min	Max	Unit
$V_{CC}$	DC Supply Voltage (Referenced to GND)	2.0	6.0	V
$V_I$	DC Input Voltage (Referenced to GND)	0	$V_{CC}$	V
$V_O$	DC Output Voltage (Referenced to GND)	0	$V_{CC}$	V
$T_A$	Operating Free-Air Temperature	-55	+85	$^{\circ}C$
$t_r, t_f$	Input Rise or Fall Rate $V_{CC} = 2.0\text{ V}$ $V_{CC} = 4.5\text{ V}$ $V_{CC} = 6.0\text{ V}$	0 0 0	1000 500 400	nS

Functional operation above the stresses listed in the Recommended Operating Ranges is not implied. Extended exposure to stresses beyond the Recommended Operating Ranges limits may affect device reliability.

6. All unused inputs of the device must be held at  $V_{CC}$  or GND to ensure proper device operation.

# MC74LV594A

## DC ELECTRICAL CHARACTERISTICS

Symbol	Parameter	Conditions	V <sub>CC</sub> , (V)	Guaranteed Limits					Unit
				T <sub>A</sub> = 25°C			T <sub>A</sub> = -55°C to 125°C		
				Min	Typ	Max	Min	Max	
V <sub>IH</sub>	Minimum High-Level Input Voltage		2.0	1.5			1.5		V
			2.3 – 6.0	0.7 x V <sub>CC</sub>			0.7 x V <sub>CC</sub>		
V <sub>IL</sub>	Maximum Low-Level Input Voltage		2.0			0.5		0.5	V
			2.3 – 6.0			0.3 x V <sub>CC</sub>		0.3 x V <sub>CC</sub>	
V <sub>OH</sub>	Minimum High-Level Output Voltage	V <sub>IN</sub> = V <sub>IH</sub> or V <sub>IL</sub>							V
		I <sub>oH</sub> = -50 μA	2.0 – 6.0	V <sub>CC</sub> - 0.1			V <sub>CC</sub> - 0.1		
		I <sub>oH</sub> = -2 mA	2.3	2			2		
		I <sub>oH</sub> = -6 mA	3.0	2.48			2.48		
		I <sub>oH</sub> = -12 mA	4.5	3.8			3.8		
V <sub>OL</sub>	Maximum Low-Level Output Voltage	V <sub>IN</sub> = V <sub>IH</sub> or V <sub>IL</sub>							V
		I <sub>oH</sub> = 50 μA	2.0 – 6.0			0.1		0.1	
		I <sub>oH</sub> = 2 mA	2.3			0.4		0.4	
		I <sub>oH</sub> = 6 mA	3.0			0.44		0.44	
		I <sub>oH</sub> = 12 mA	4.5			0.55		0.55	
I <sub>IN</sub>	Maximum Input Leakage Current	V <sub>I</sub> = V <sub>CC</sub> or GND	6.0		±0.1		±1		μA
I <sub>CC</sub>	Maximum Supply Current	V <sub>I</sub> = V <sub>CC</sub> or GND, I <sub>O</sub> = 0 A	6.0			8.0		80	μA
C <sub>I</sub>	Input Capacitance	V <sub>I</sub> = V <sub>CC</sub> or GND	3.3		3.5				pF

Product parametric performance is indicated in the Electrical Characteristics for the listed test conditions, unless otherwise noted. Product performance may not be indicated by the Electrical Characteristics if operated under different conditions.

# MC74LV594A

## TIMING SPECIFICATIONS (See Figure 3)

Symbol	Parameter	Conditions	V <sub>CC</sub> , (V)	T <sub>A</sub> = 25°C		T <sub>A</sub> = -55°C to 125°C		Unit			
				Min	Max	Min	Max				
t <sub>w</sub>	Pulse Duration	RCLK or SRCLK High or Low	2.3 – 2.7	7		7.5		ns			
			3.0 – 3.6	5.5		5.5					
			4.5 – 5.5	5		5					
		RCLR or SRCLR Low	2.3 – 2.7	6		6.5					
			3.0 – 3.6	5		5					
			4.5 – 5.5	5.2		5.2					
t <sub>su</sub>	Setup Time	SER before SRCLK↑	2.3 – 2.7	5.5		5.5		ns			
			3.0 – 3.6	3.5		3.5					
			4.5 – 5.5	3		3					
		SRCLK↑ before RCLK↑	2.3 – 2.7	8		9					
			3.0 – 3.6	8		8.5					
			4.5 – 5.5	5		5					
		SRCLR Low before RCLK↑	2.3 – 2.7	8.5		9.5					
			3.0 – 3.6	8		9					
			4.5 – 5.5	5		5					
		SRCLR High (Inactive) before SRCLK↑	2.3 – 2.7	6		6.8					
			3.0 – 3.6	4.2		4.8					
			4.5 – 5.5	2.9		3.3					
		RCLR High (Inactive) before RCLK↑	2.3 – 2.7	6.7		7.6					
			3.0 – 3.6	4.6		5.3					
			4.5 – 5.5	3.2		3.7					
		t <sub>H</sub>	Hold Time	SER after SRCLK↑	2.3 – 2.7	1.5			1.5		ns
					3.0 – 3.6	1.5			1.5		
					4.5 – 5.5	2			2		

# MC74LV594A

## AC CHARACTERISTICS (See Figure 3)

Symbol	Parameter	Load Conditions	Input to Output	V <sub>CC</sub> (V)	Guaranteed Limits					Unit
					T <sub>A</sub> = 25°C			T <sub>A</sub> = -55°C to 125°C		
					Min	Typ	Max	Min	Max	
f <sub>MAX</sub>		C <sub>L</sub> = 15 pF		2.3 – 2.7	65	80		45		MHz
				3.0 – 3.6	80	120		70		
				4.5 – 5.5	135	170		115		
		C <sub>L</sub> = 50 pF		2.3 – 2.7	50	51		40		
				3.0 – 3.6	70	74		55		
				4.5 – 5.5	115	120		90		
t <sub>PLH</sub>	Propagation Delay Low to High	C <sub>L</sub> = 15 pF	RCLK to Q <sub>A</sub> -Q <sub>H</sub>	2.3 – 2.7			27.5	1	32.5	ns
				3.0 – 3.6			18	1	22.5	
				4.5 – 5.5			12	1	15	
			SRCLK to Q <sub>H</sub> '	2.3 – 2.7			27.5	1	32	
				3.0 – 3.6			18	1	22	
				4.5 – 5.5			12.5	1	12	
		C <sub>L</sub> = 50 pF	RCLK to Q <sub>A</sub> -Q <sub>H</sub>	2.3 – 2.7		22.1	25.0	1	30.0	
				3.0 – 3.6		15.6	17.5	1	21.0	
				4.5 – 5.5		11.5	12.5	1	15.5	
			SRCLK to Q <sub>H</sub> '	2.3 – 2.7		21.6	25.5	1	29.5	
				3.0 – 3.6		15.2	18.0	1	21.0	
				4.5 – 5.5		10.9	12.5	1	15.0	
t <sub>PHL</sub>	Propagation Delay High to Low	C <sub>L</sub> = 15 pF	RCLK to Q <sub>A</sub> -Q <sub>H</sub>	2.3 – 2.7			23	1	27.5	ns
				3.0 – 3.6			15.5	1	19	
				4.5 – 5.5			11	1	14	
			SRCLK to Q <sub>H</sub> '	2.3 – 2.7			23.5	1	27	
				3.0 – 3.6			16	1	19	
				4.5 – 5.5			11	1	13.5	
			RCLR to Q <sub>A</sub> -Q <sub>H</sub>	2.3 – 2.7			20.5	1	25	
				3.0 – 3.6			14.5	1	17.5	
				4.5 – 5.5			10	1	12	
			SRCLR to Q <sub>H</sub> '	2.3 – 2.7				1	23	
				3.0 – 3.6			13	1	16	
				4.5 – 5.5			9	1	11	
		C <sub>L</sub> = 50 pF	RCLK to Q <sub>A</sub> -Q <sub>H</sub>	2.3 – 2.7		19.7	23.0	1	27.0	
				3.0 – 3.6		14.0	16.5	1	19.5	
				4.5 – 5.5		10.1	11.5	1	13.5	
			SRCLK to Q <sub>H</sub> '	2.3 – 2.7		18.4	21.5	1	25.0	
				3.0 – 3.6		13.1	15.0	1	18.0	
				4.5 – 5.5		9.0	10.5	1	12.5	
			RCLR to Q <sub>A</sub> -Q <sub>H</sub>	2.3 – 2.7		25.7	30.0	1	35.0	
				3.0 – 3.6		17.6	20.0	1	24.5	
				4.5 – 5.5		12.2	13.5	1	17.0	
			SRCLR to Q <sub>H</sub> '	2.3 – 2.7		25.3	30.0	1	34	
				3.0 – 3.6		17.3	20.0	1	24.0	
				4.5 – 5.5		11.9	14.0	1	16.5	

# MC74LV594A

## NOISE CHARACTERISTICS, $V_{CC} = 3.3\text{ V}$ , $C_L = 50\text{ pF}$ , $T_A = 25^\circ\text{C}$

Symbol	Parameter	Min	Typ	Max	Unit
$V_{OL(P)}$	Quiet Output, Maximum Dynamic $V_{OL}$		0.8	0.8	V
$V_{OL(V)}$	Quiet Output, Minimum Dynamic $V_{OL}$		-0.1	-0.8	V
$V_{OH(V)}$	Quiet Output, Minimum Dynamic $V_{OH}$		2.8		V
$V_{IH(D)}$	High-Level Dynamic Input Voltage	2.31			V
$V_{IL(D)}$	Low-Level Dynamic Input Voltage			0.99	V

## POWER DISSIPATION CHARACTERISTICS, $T_A = 25^\circ\text{C}$

Symbol	Parameter	Test Conditions	$V_{CC}$ (V)	Typ	Unit
$C_{PD}$	Power Dissipation Capacitance	$f = 10\text{ MHz}$	3.3	93	pF
			5	112	

# MC74LV594A

## PARAMETER MEASUREMENT INFORMATION

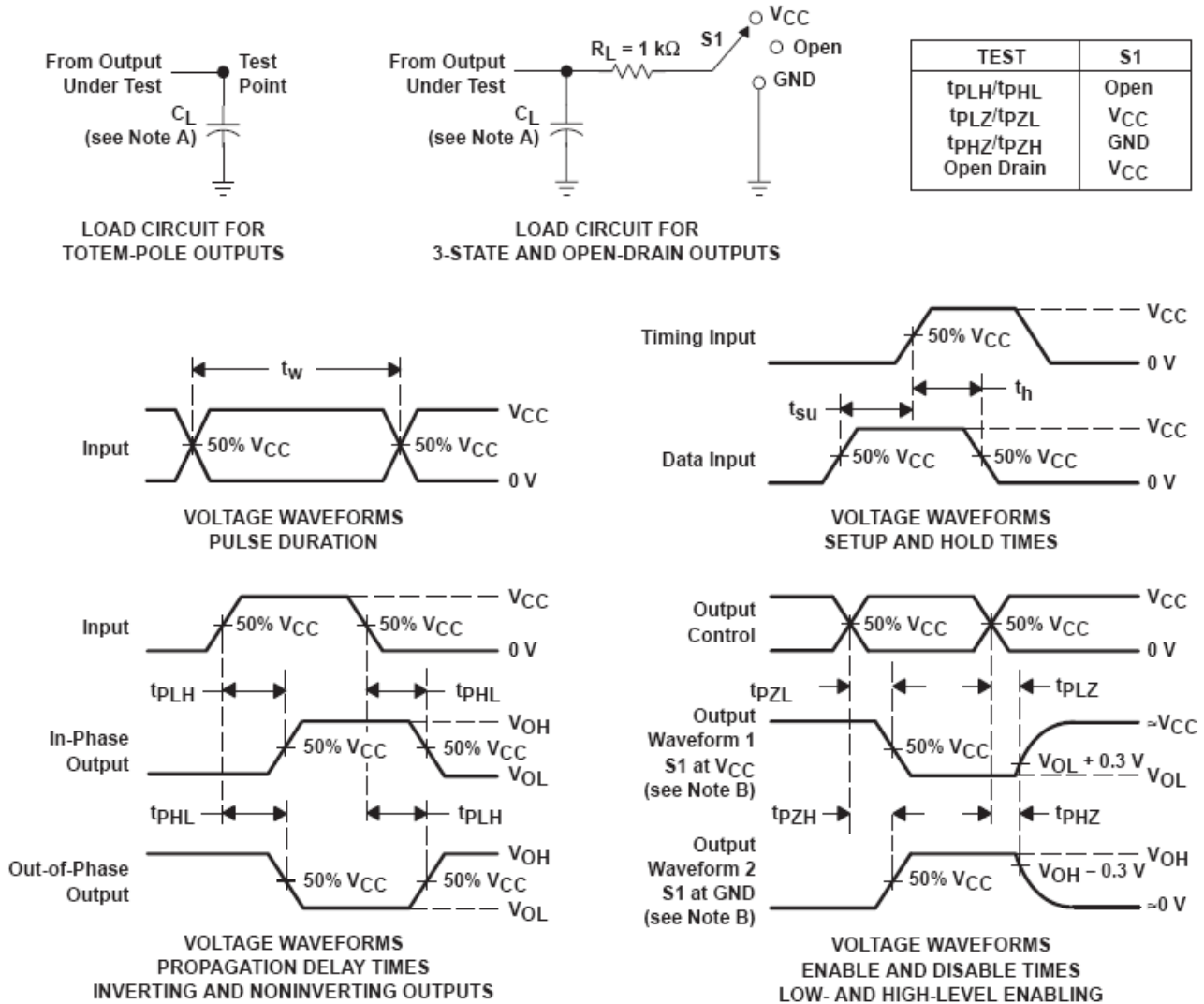

- NOTES:
- A.  $C_L$  includes probe and jig capacitance.
  - B. Waveform 1 is for an output with internal conditions such that the output is low, except when disabled by the output control. Waveform 2 is for an output with internal conditions such that the output is high, except when disabled by the output control.
  - C. All input pulses are supplied by generators having the following characteristics:  $PRR \leq 1\text{ MHz}$ ,  $Z_O = 50\ \Omega$ ,  $t_r \leq 3\text{ ns}$ ,  $t_f \leq 3\text{ ns}$ .
  - D. The outputs are measured one at a time, with one input transition per measurement.
  - E.  $t_{PLZ}$  and  $t_{PHZ}$  are the same as  $t_{dis}$ .
  - F.  $t_{PZL}$  and  $t_{PZH}$  are the same as  $t_{en}$ .
  - G.  $t_{PHL}$  and  $t_{PLH}$  are the same as  $t_{pd}$ .
  - H. All parameters and waveforms are not applicable to all devices.

Figure 3. Load Circuit and Voltage Waveforms

# MECHANICAL CASE OUTLINE PACKAGE DIMENSIONS

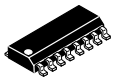

SCALE 1:1

SOIC-16  
CASE 751B-05  
ISSUE K

DATE 29 DEC 2006

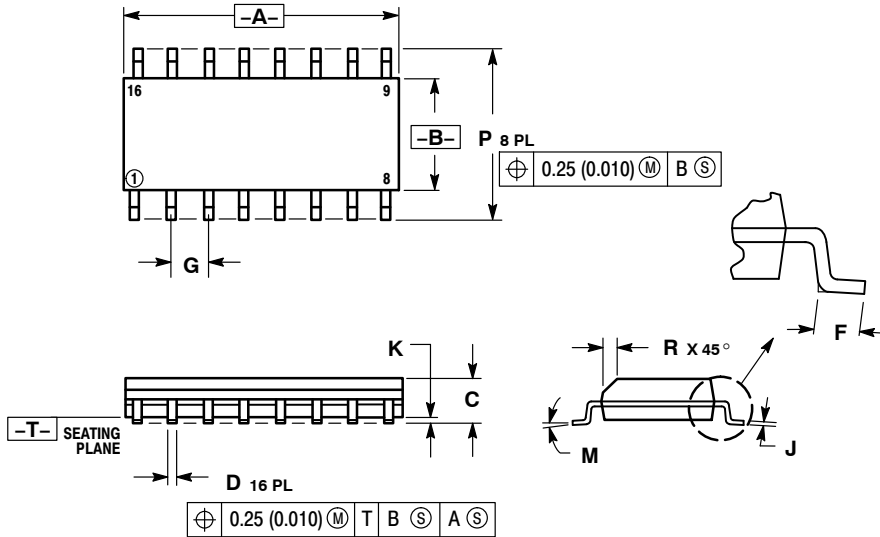

NOTES:

1. DIMENSIONING AND TOLERANCING PER ANSI Y14.5M, 1982.
2. CONTROLLING DIMENSION: MILLIMETER.
3. DIMENSIONS A AND B DO NOT INCLUDE MOLD PROTRUSION.
4. MAXIMUM MOLD PROTRUSION 0.15 (0.006) PER SIDE.
5. DIMENSION D DOES NOT INCLUDE DAMBAR PROTRUSION. ALLOWABLE DAMBAR PROTRUSION SHALL BE 0.127 (0.005) TOTAL IN EXCESS OF THE D DIMENSION AT MAXIMUM MATERIAL CONDITION.

DIM	MILLIMETERS		INCHES	
	MIN	MAX	MIN	MAX
A	9.80	10.00	0.386	0.393
B	3.80	4.00	0.150	0.157
C	1.35	1.75	0.054	0.068
D	0.35	0.49	0.014	0.019
F	0.40	1.25	0.016	0.049
G	1.27 BSC		0.050 BSC	
J	0.19	0.25	0.008	0.009
K	0.10	0.25	0.004	0.009
M	0° 7°		0° 7°	
P	5.80	6.20	0.229	0.244
R	0.25	0.50	0.010	0.019

- |  |  |  |  |
|--|--|--|--|
| <p>STYLE 1:</p> <p>PIN 1. COLLECTOR</p> <p>2. BASE</p> <p>3. EMITTER</p> <p>4. NO CONNECTION</p> <p>5. EMITTER</p> <p>6. BASE</p> <p>7. COLLECTOR</p> <p>8. COLLECTOR</p> <p>9. BASE</p> <p>10. EMITTER</p> <p>11. NO CONNECTION</p> <p>12. EMITTER</p> <p>13. BASE</p> <p>14. COLLECTOR</p> <p>15. EMITTER</p> <p>16. COLLECTOR</p>                           | <p>STYLE 2:</p> <p>PIN 1. CATHODE</p> <p>2. ANODE</p> <p>3. NO CONNECTION</p> <p>4. CATHODE</p> <p>5. CATHODE</p> <p>6. NO CONNECTION</p> <p>7. ANODE</p> <p>8. CATHODE</p> <p>9. CATHODE</p> <p>10. ANODE</p> <p>11. NO CONNECTION</p> <p>12. CATHODE</p> <p>13. CATHODE</p> <p>14. NO CONNECTION</p> <p>15. ANODE</p> <p>16. CATHODE</p> | <p>STYLE 3:</p> <p>PIN 1. COLLECTOR, DYE #1</p> <p>2. BASE, #1</p> <p>3. EMITTER, #1</p> <p>4. COLLECTOR, #1</p> <p>5. COLLECTOR, #2</p> <p>6. BASE, #2</p> <p>7. EMITTER, #2</p> <p>8. COLLECTOR, #2</p> <p>9. COLLECTOR, #3</p> <p>10. BASE, #3</p> <p>11. EMITTER, #3</p> <p>12. COLLECTOR, #3</p> <p>13. COLLECTOR, #4</p> <p>14. BASE, #4</p> <p>15. EMITTER, #4</p> <p>16. COLLECTOR, #4</p>   | <p>STYLE 4:</p> <p>PIN 1. COLLECTOR, DYE #1</p> <p>2. COLLECTOR, #1</p> <p>3. COLLECTOR, #2</p> <p>4. COLLECTOR, #2</p> <p>5. COLLECTOR, #3</p> <p>6. COLLECTOR, #3</p> <p>7. COLLECTOR, #4</p> <p>8. COLLECTOR, #4</p> <p>9. BASE, #4</p> <p>10. EMITTER, #4</p> <p>11. BASE, #3</p> <p>12. EMITTER, #3</p> <p>13. BASE, #2</p> <p>14. EMITTER, #2</p> <p>15. BASE, #1</p> <p>16. EMITTER, #1</p> |
| <p>STYLE 5:</p> <p>PIN 1. DRAIN, DYE #1</p> <p>2. DRAIN, #1</p> <p>3. DRAIN, #2</p> <p>4. DRAIN, #2</p> <p>5. DRAIN, #3</p> <p>6. DRAIN, #3</p> <p>7. DRAIN, #4</p> <p>8. DRAIN, #4</p> <p>9. GATE, #4</p> <p>10. SOURCE, #4</p> <p>11. GATE, #3</p> <p>12. SOURCE, #3</p> <p>13. GATE, #2</p> <p>14. SOURCE, #2</p> <p>15. GATE, #1</p> <p>16. SOURCE, #1</p> | <p>STYLE 6:</p> <p>PIN 1. CATHODE</p> <p>2. CATHODE</p> <p>3. CATHODE</p> <p>4. CATHODE</p> <p>5. CATHODE</p> <p>6. CATHODE</p> <p>7. CATHODE</p> <p>8. CATHODE</p> <p>9. ANODE</p> <p>10. ANODE</p> <p>11. ANODE</p> <p>12. ANODE</p> <p>13. ANODE</p> <p>14. ANODE</p> <p>15. ANODE</p> <p>16. ANODE</p>                                 | <p>STYLE 7:</p> <p>PIN 1. SOURCE N-CH</p> <p>2. COMMON DRAIN (OUTPUT)</p> <p>3. COMMON DRAIN (OUTPUT)</p> <p>4. GATE P-CH</p> <p>5. COMMON DRAIN (OUTPUT)</p> <p>6. COMMON DRAIN (OUTPUT)</p> <p>7. COMMON DRAIN (OUTPUT)</p> <p>8. SOURCE P-CH</p> <p>9. SOURCE P-CH</p> <p>10. COMMON DRAIN (OUTPUT)</p> <p>11. COMMON DRAIN (OUTPUT)</p> <p>12. COMMON DRAIN (OUTPUT)</p> <p>13. GATE N-CH</p> <p>14. COMMON DRAIN (OUTPUT)</p> <p>15. COMMON DRAIN (OUTPUT)</p> <p>16. SOURCE N-CH</p> |  |

RECOMMENDED  
SOLDERING FOOTPRINT\*

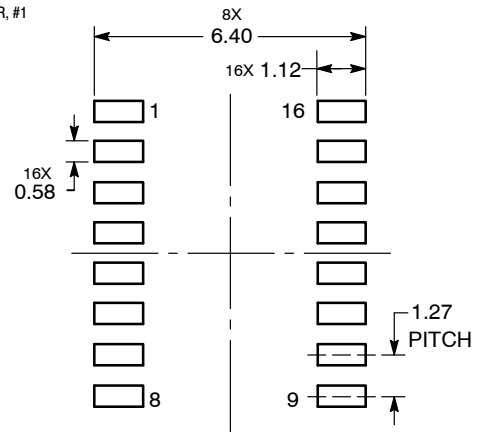

DIMENSIONS: MILLIMETERS

\*For additional information on our Pb-Free strategy and soldering details, please download the onsemi Soldering and Mounting Techniques Reference Manual, SOLDERRM/D.

DOCUMENT NUMBER:	98ASB42566B	Electronic versions are uncontrolled except when accessed directly from the Document Repository. Printed versions are uncontrolled except when stamped "CONTROLLED COPY" in red.
DESCRIPTION:	SOIC-16	PAGE 1 OF 1

onsemi and onsemi are trademarks of Semiconductor Components Industries, LLC dba onsemi or its subsidiaries in the United States and/or other countries. onsemi reserves the right to make changes without further notice to any products herein. onsemi makes no warranty, representation or guarantee regarding the suitability of its products for any particular purpose, nor does onsemi assume any liability arising out of the application or use of any product or circuit, and specifically disclaims any and all liability, including without limitation special, consequential or incidental damages. onsemi does not convey any license under its patent rights nor the rights of others.

# MECHANICAL CASE OUTLINE PACKAGE DIMENSIONS

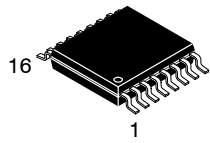

**TSSOP-16 WB**  
CASE 948F  
ISSUE B

DATE 19 OCT 2006

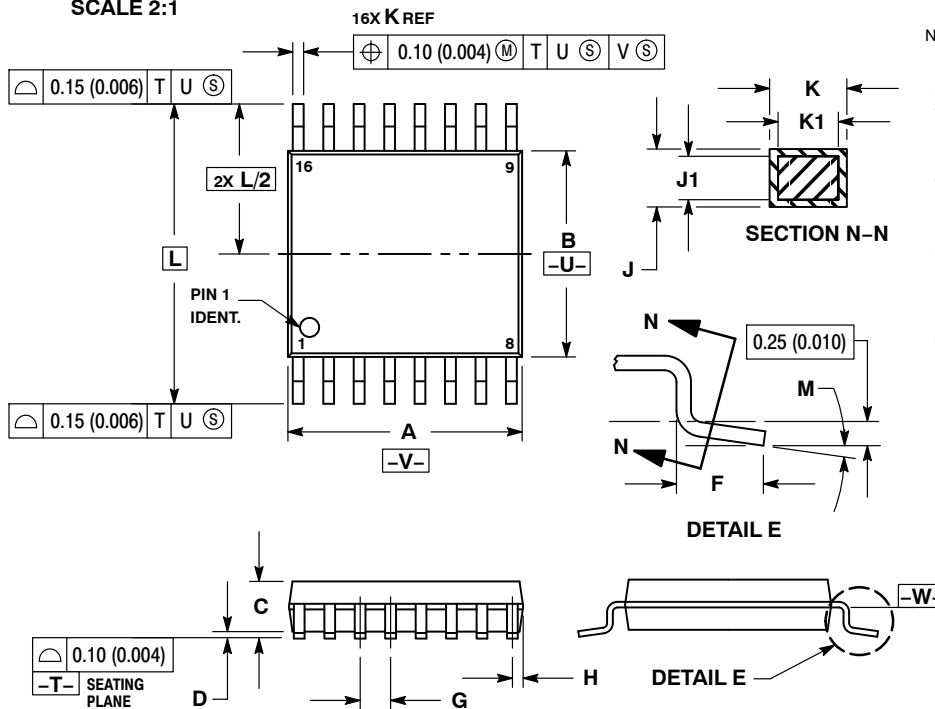

**NOTES:**

1. DIMENSIONING AND TOLERANCING PER ANSI Y14.5M, 1982.
2. CONTROLLING DIMENSION: MILLIMETER.
3. DIMENSION A DOES NOT INCLUDE MOLD FLASH, PROTRUSIONS OR GATE BURRS. MOLD FLASH OR GATE BURRS SHALL NOT EXCEED 0.15 (0.006) PER SIDE.
4. DIMENSION B DOES NOT INCLUDE INTERLEAD FLASH OR PROTRUSION. INTERLEAD FLASH OR PROTRUSION SHALL NOT EXCEED 0.25 (0.010) PER SIDE.
5. DIMENSION K DOES NOT INCLUDE DAMBAR PROTRUSION. ALLOWABLE DAMBAR PROTRUSION SHALL BE 0.08 (0.003) TOTAL IN EXCESS OF THE K DIMENSION AT MAXIMUM MATERIAL CONDITION.
6. TERMINAL NUMBERS ARE SHOWN FOR REFERENCE ONLY.
7. DIMENSION A AND B ARE TO BE DETERMINED AT DATUM PLANE -W-.

DIM	MILLIMETERS		INCHES	
	MIN	MAX	MIN	MAX
A	4.90	5.10	0.193	0.200
B	4.30	4.50	0.169	0.177
C	---	1.20	---	0.047
D	0.05	0.15	0.002	0.006
F	0.50	0.75	0.020	0.030
G	0.65 BSC		0.026 BSC	
H	0.18	0.28	0.007	0.011
J	0.09	0.20	0.004	0.008
J1	0.09	0.16	0.004	0.006
K	0.19	0.30	0.007	0.012
K1	0.19	0.25	0.007	0.010
L	6.40 BSC		0.252 BSC	
M	0°	8°	0°	8°

**RECOMMENDED  
SOLDERING FOOTPRINT\***

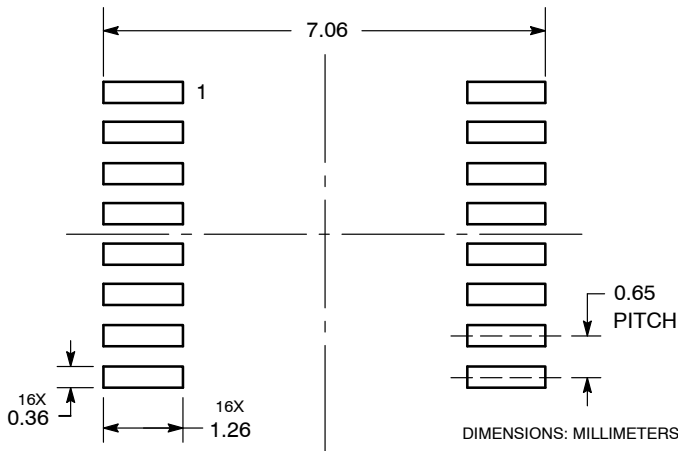

**GENERIC  
MARKING DIAGRAM\***

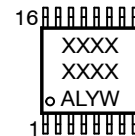

- XXXX = Specific Device Code
- A = Assembly Location
- L = Wafer Lot
- Y = Year
- W = Work Week
- G or ■ = Pb-Free Package

\*This information is generic. Please refer to device data sheet for actual part marking. Pb-Free indicator, "G" or microdot "■", may or may not be present. Some products may not follow the Generic Marking.

\*For additional information on our Pb-Free strategy and soldering details, please download the **onsemi** Soldering and Mounting Techniques Reference Manual, SOLDERRM/D.

<b>DOCUMENT NUMBER:</b>	<b>98ASH70247A</b>	Electronic versions are uncontrolled except when accessed directly from the Document Repository. Printed versions are uncontrolled except when stamped "CONTROLLED COPY" in red.
<b>DESCRIPTION:</b>	<b>TSSOP-16</b>	<b>PAGE 1 OF 1</b>

onsemi and onsemi are trademarks of Semiconductor Components Industries, LLC dba onsemi or its subsidiaries in the United States and/or other countries. onsemi reserves the right to make changes without further notice to any products herein. onsemi makes no warranty, representation or guarantee regarding the suitability of its products for any particular purpose, nor does onsemi assume any liability arising out of the application or use of any product or circuit, and specifically disclaims any and all liability, including without limitation special, consequential or incidental damages. onsemi does not convey any license under its patent rights nor the rights of others.

**onsemi**, **Onsemi**, and other names, marks, and brands are registered and/or common law trademarks of Semiconductor Components Industries, LLC dba "**onsemi**" or its affiliates and/or subsidiaries in the United States and/or other countries. **onsemi** owns the rights to a number of patents, trademarks, copyrights, trade secrets, and other intellectual property. A listing of **onsemi**'s product/patent coverage may be accessed at [www.onsemi.com/site/pdf/Patent-Marking.pdf](http://www.onsemi.com/site/pdf/Patent-Marking.pdf). **onsemi** reserves the right to make changes at any time to any products or information herein, without notice. The information herein is provided "as-is" and **onsemi** makes no warranty, representation or guarantee regarding the accuracy of the information, product features, availability, functionality, or suitability of its products for any particular purpose, nor does **onsemi** assume any liability arising out of the application or use of any product or circuit, and specifically disclaims any and all liability, including without limitation special, consequential or incidental damages. Buyer is responsible for its products and applications using **onsemi** products, including compliance with all laws, regulations and safety requirements or standards, regardless of any support or applications information provided by **onsemi**. "Typical" parameters which may be provided in **onsemi** data sheets and/or specifications can and do vary in different applications and actual performance may vary over time. All operating parameters, including "Typicals" must be validated for each customer application by customer's technical experts. **onsemi** does not convey any license under any of its intellectual property rights nor the rights of others. **onsemi** products are not designed, intended, or authorized for use as a critical component in life support systems or any FDA Class 3 medical devices or medical devices with a same or similar classification in a foreign jurisdiction or any devices intended for implantation in the human body. Should Buyer purchase or use **onsemi** products for any such unintended or unauthorized application, Buyer shall indemnify and hold **onsemi** and its officers, employees, subsidiaries, affiliates, and distributors harmless against all claims, costs, damages, and expenses, and reasonable attorney fees arising out of, directly or indirectly, any claim of personal injury or death associated with such unintended or unauthorized use, even if such claim alleges that **onsemi** was negligent regarding the design or manufacture of the part. **onsemi** is an Equal Opportunity/Affirmative Action Employer. This literature is subject to all applicable copyright laws and is not for resale in any manner.

## ADDITIONAL INFORMATION

### TECHNICAL PUBLICATIONS:

Technical Library: [www.onsemi.com/design/resources/technical-documentation](http://www.onsemi.com/design/resources/technical-documentation)  
onsemi Website: [www.onsemi.com](http://www.onsemi.com)

### ONLINE SUPPORT: [www.onsemi.com/support](http://www.onsemi.com/support)

For additional information, please contact your local Sales Representative at [www.onsemi.com/support/sales](http://www.onsemi.com/support/sales)



## Looking for pricing, stock, or lifecycle information?

Click below to explore more details on WIN SOURCE:

 [View MC74LV594ADR2G on WIN SOURCE](#)

 [ON Semiconductor](#) Information

## Optimize Your Supply Chain with WIN SOURCE Solutions

-  Global Sourcing Solution
-  Obsolete Management
-  Cost Control Management
-  Shortage Management
-  Alternative Solution
-  Excess Inventory Management