



**THE DATASHEET OF  
MC68HC705JP7CDW**



**MC68HC705JJ7**  
**MC68HC705JP7**  
**MC68HC705SJ7**  
**MC68HC705SP7**  
**MC68HRC705JJ7**  
**MC68HRC705JP7**

Advance Information Data Sheet

**M68HC05**  
**Microcontrollers**

MC68HC705JJ7  
Rev. 4.1  
09/2005

[freescale.com](http://freescale.com)





**MC68HC705JJ7**  
**MC68HC705SJ7**  
**MC68HRC705JJ7**

**MC68HRC705SJ7**  
**MC68HC705JP7**  
**MC68HC705SP7**

**Advance Information Data Sheet**

---

To provide the most up-to-date information, the revision of our documents on the World Wide Web will be the most current. Your printed copy may be an earlier revision. To verify you have the latest information available, refer to:

<http://www.freescale.com/>

Freescale™ and the Freescale logo are trademarks of Freescale Semiconductor, Inc.

© Freescale Semiconductor, Inc., 2005. All rights reserved.

## Revision History

The following revision history table summarizes changes contained in this document. For your convenience, the page number designators have been linked to the appropriate location.

## Revision History

Date	Revision Level	Description	Page Number(s)
August, 2001	4.0	General reformat to bring document up to current publication standards	All
		References to MC68HRC705SJ7 and MC68HRC705SP7 removed throughout	All
		Figure 7-9. PB4/AN4/TCMP/CMP1 Pin I/O Circuit — Change label of register \$1FF0 from mask option register to COP register	94
		Table 7-2. Port B Pin Functions — PB0–PB4 — Change heading under Comparator 1 from OPT in MOR to OPT in COPR	96
		12.4 PEPROM Programming — Contact information updated	179
		Figure 13-3. EPROM Security in COP and Security Register (COPR) — Figure title change	188
		13.4 EPROM Programming — Contact information updated and corrected reference to COP register from COP to COPR	189
		15.15 SIOP Timing (VDD = 5.0 Vdc) — Value change for clock (SCK) low time	225
		15.16 SIOP Timing (VDD = 3.0 Vdc) — Value change for clock (SCK) low time	226
		Section 15. Electrical Specifications — Added Figure 15-1 through Figure 15-10 and Figure 15-12	213, 214, 219, 223, and 227
September, 2005	4.1	Updated to meet Freescale identity guidelines.	Throughout

## List of Chapters

Chapter 1 General Description . . . . .	13
Chapter 2 Memory . . . . .	21
Chapter 3 Central Processor Unit (CPU). . . . .	29
Chapter 4 Interrupts . . . . .	33
Chapter 5 Resets . . . . .	43
Chapter 6 Operating Modes . . . . .	49
Chapter 7 Parallel Input/Output . . . . .	55
Chapter 8 Analog Subsystem . . . . .	71
Chapter 9 Simple Synchronous Serial Interface . . . . .	95
Chapter 10 Core Timer . . . . .	101
Chapter 11 Programmable Timer. . . . .	105
Chapter 12 Personality EPROM (PEPROM) . . . . .	115
Chapter 13 EPROM/OTPROM. . . . .	119
Chapter 14 Instruction Set . . . . .	125
Chapter 15 Electrical Specifications . . . . .	139
Chapter 16 Mechanical Specifications . . . . .	157
Chapter 17 Ordering Information. . . . .	161



# Table of Contents

## Chapter 1 General Description

1.1	Introduction .....	13
1.2	Features .....	13
1.3	Device Options .....	14
1.4	Functional Pin Description .....	16
1.5	V <sub>DD</sub> and V <sub>SS</sub> Pins .....	17
1.6	OSC1 and OSC2 Pins .....	17
1.6.1	Crystal Oscillator .....	17
1.6.2	Ceramic Resonator Oscillator .....	18
1.6.3	RC Oscillator .....	18
1.6.4	External Clock .....	18
1.6.5	Internal Low-Power Oscillator .....	18
1.7	$\overline{\text{RESET}}$ Pin .....	18
1.8	$\overline{\text{IRQ}}/\text{V}_{\text{PP}}$ Pin .....	19
1.9	PA0–PA5 .....	19
1.10	PB0–PB7 .....	19
1.11	PC0–PC7 (MC68HC705JP7) .....	19

## Chapter 2 Memory

2.1	Introduction .....	21
2.2	Memory Map .....	21
2.3	Input/Output Registers .....	21
2.4	User and Interrupt Vector Mapping .....	26
2.5	Random-Access Memory (RAM) .....	26
2.6	Erasable Programmable Read-Only Memory (EPROM) .....	26
2.7	COP Register .....	27

## Chapter 3 Central Processor Unit (CPU)

3.1	Introduction .....	29
3.2	Accumulator .....	29
3.3	Index Register .....	30
3.4	Stack Pointer .....	30
3.5	Program Counter .....	30
3.6	Condition Code Register .....	31
3.7	Arithmetic/Logic Unit (ALU) .....	31

## Chapter 4 Interrupts

4.1	Introduction . . . . .	33
4.2	Interrupt Vectors . . . . .	33
4.3	Interrupt Processing . . . . .	34
4.4	Software Interrupt . . . . .	36
4.5	External Interrupts . . . . .	36
4.5.1	IRQ/V <sub>PP</sub> Pin . . . . .	36
4.5.2	PA0–PA3 Pins . . . . .	37
4.5.3	IRQ Status and Control Register (ISCR) . . . . .	38
4.6	Core Timer Interrupts . . . . .	39
4.6.1	Core Timer Overflow Interrupt . . . . .	39
4.6.2	Real-Time Interrupt . . . . .	39
4.7	Programmable Timer Interrupts . . . . .	40
4.7.1	Input Capture Interrupt . . . . .	40
4.7.2	Output Compare Interrupt . . . . .	40
4.7.3	Timer Overflow Interrupt . . . . .	40
4.8	Serial Interrupts . . . . .	40
4.9	Analog Interrupts . . . . .	41
4.9.1	Comparator Input Match Interrupt . . . . .	41
4.9.2	Input Capture Interrupt . . . . .	41

## Chapter 5 Resets

5.1	Introduction . . . . .	43
5.2	Power-On Reset . . . . .	44
5.3	External Reset . . . . .	44
5.4	Internal Resets . . . . .	44
5.4.1	Power-On Reset (POR) . . . . .	44
5.4.2	Computer Operating Properly (COP) Reset . . . . .	45
5.4.3	Low-Voltage Reset (LVR) . . . . .	45
5.4.4	Illegal Address Reset . . . . .	46
5.5	Reset States . . . . .	46
5.5.1	CPU . . . . .	46
5.5.2	I/O Registers . . . . .	46
5.5.3	Core Timer . . . . .	46
5.5.4	COP Watchdog . . . . .	47
5.5.5	16-Bit Programmable Timer . . . . .	47
5.5.6	Serial Interface . . . . .	47
5.5.7	Analog Subsystem . . . . .	47
5.5.8	External Oscillator and Internal Low-Power Oscillator . . . . .	47

## Chapter 6 Operating Modes

6.1	Introduction . . . . .	49
6.2	Oscillator Source . . . . .	49

6.3	Low-Power Modes . . . . .	50
6.3.1	Stop Mode . . . . .	52
6.3.2	Wait Mode . . . . .	53
6.3.3	Halt Mode . . . . .	53
6.3.4	Data-Retention Mode . . . . .	54

**Chapter 7  
Parallel Input/Output**

7.1	Introduction . . . . .	55
7.2	Port A . . . . .	55
7.2.1	Port A Data Register . . . . .	55
7.2.2	Data Direction Register A . . . . .	56
7.2.3	Pulldown Register A . . . . .	56
7.2.4	Port A External Interrupts . . . . .	57
7.2.5	Port A Logic . . . . .	57
7.3	Port B . . . . .	58
7.3.1	Port B Data Register . . . . .	58
7.3.2	Data Direction Register B . . . . .	59
7.3.3	Pulldown Register B . . . . .	59
7.3.4	Port B Logic . . . . .	60
7.3.5	PB0, PBI, PB2, and PB3 Logic . . . . .	60
7.3.6	PB4/AN4/TCMP/CMP1 Logic . . . . .	61
7.3.7	PB5/SDO Logic . . . . .	63
7.3.8	PB6/SDI Logic . . . . .	64
7.3.9	PB7/SCK Logic . . . . .	65
7.4	Port C (28-Pin Versions Only) . . . . .	67
7.4.1	Port C Data Register . . . . .	67
7.4.2	Data Direction Register C . . . . .	67
7.4.3	Port C Pulldown Devices . . . . .	68
7.4.4	Port C Logic . . . . .	68
7.5	Port Transitions . . . . .	69

**Chapter 8  
Analog Subsystem**

8.1	Introduction . . . . .	71
8.2	Analog Multiplex Register . . . . .	73
8.3	Analog Control Register . . . . .	76
8.4	Analog Status Register . . . . .	79
8.5	A/D Conversion Methods . . . . .	81
8.6	Voltage Measurement Methods . . . . .	89
8.6.1	Absolute Voltage Readings . . . . .	90
8.6.1.1	Internal Absolute Reference . . . . .	90
8.6.1.2	External Absolute Reference . . . . .	90
8.6.2	Ratiometric Voltage Readings . . . . .	91
8.6.2.1	Internal Ratiometric Reference . . . . .	91
8.6.2.2	External Ratiometric Reference . . . . .	91

## Table of Contents

8.7	Voltage Comparator Features	92
8.7.1	Voltage Comparator 1	92
8.7.2	Voltage Comparator 2	93
8.8	Current Source Features	93
8.9	Internal Temperature Sensing Diode Features	93
8.10	Sample and Hold	93
8.11	Port B Interaction with Analog Inputs	94
8.12	Port B Pins as Inputs	94
8.13	Port B Pulldowns	94
8.14	Noise Sensitivity	94

## Chapter 9 Simple Synchronous Serial Interface

9.1	Introduction	95
9.2	SIOP Signal Format	96
9.2.1	Serial Clock (SCK)	96
9.2.2	Serial Data Input (SDI)	97
9.2.3	Serial Data Output (SDO)	97
9.3	SIOP Registers	97
9.3.1	SIOP Control Register (SCR)	97
9.3.2	SIOP Status Register	99
9.3.3	SIOP Data Register	100

## Chapter 10 Core Timer

10.1	Introduction	101
10.2	Core Timer Status and Control Register	102
10.3	Core Timer Counter Register	103
10.4	COP Watchdog	103

## Chapter 11 Programmable Timer

11.1	Introduction	105
11.2	Timer Registers	107
11.3	Alternate Counter Registers	108
11.4	Input Capture Registers	109
11.5	Output Compare Registers	110
11.6	Timer Control Register	112
11.7	Timer Status Register	113
11.8	Timer Operation during Wait Mode	114
11.9	Timer Operation during Stop Mode	114
11.10	Timer Operation during Halt Mode	114

**Chapter 12**  
**Personality EPROM (PEPROM)**

12.1	Introduction	115
12.2	PEPROM Registers	116
12.2.1	PEPROM Bit Select Register	116
12.2.2	PEPROM Status and Control Register	116
12.3	PEPROM Programming	117
12.4	PEPROM Reading	118
12.5	PEPROM Erasing	118

**Chapter 13**  
**EPROM/OTEPROM**

13.1	Introduction	119
13.2	EPROM Registers	119
13.2.1	EPROM Programming Register	119
13.2.2	Mask Option Register	120
13.2.3	EPROM Security Bit	122
13.3	EPROM Programming	122
13.3.1	MOR Programming	123
13.3.2	EPMSEC Programming	123
13.4	EPROM Erasing	123

**Chapter 14**  
**Instruction Set**

14.1	Introduction	125
14.2	Addressing Modes	125
14.2.1	Inherent	125
14.2.2	Immediate	125
14.2.3	Direct	125
14.2.4	Extended	126
14.2.5	Indexed, No Offset	126
14.2.6	Indexed, 8-Bit Offset	126
14.2.7	Indexed, 16-Bit Offset	126
14.2.8	Relative	126
14.3	Instruction Types	127
14.3.1	Register/Memory Instructions	127
14.3.2	Read-Modify-Write Instructions	128
14.3.3	Jump/Branch Instructions	129
14.3.4	Bit Manipulation Instructions	130
14.3.5	Control Instructions	130
14.4	Instruction Set Summary	131
14.5	Opcode Map	136

**Chapter 15**  
**Electrical Specifications**

15.1	Introduction . . . . .	139
15.2	Maximum Ratings . . . . .	139
15.3	Operating Temperature Range . . . . .	139
15.4	Thermal Characteristics . . . . .	139
15.5	Supply Current Characteristics ( $V_{DD} = 4.5$ to $5.5$ Vdc) . . . . .	140
15.6	Supply Current Characteristics ( $V_{DD} = 2.7$ to $3.3$ Vdc) . . . . .	140
15.7	DC Electrical Characteristics (5.0 Vdc) . . . . .	143
15.8	DC Electrical Characteristics (3.0 Vdc) . . . . .	144
15.9	Analog Subsystem Characteristics (5.0 Vdc) . . . . .	145
15.10	Analog Subsystem Characteristics (3.0 Vdc) . . . . .	146
15.11	Control Timing (5.0 Vdc) . . . . .	148
15.12	Control Timing (3.0 Vdc) . . . . .	149
15.13	PEPROM and EPROM Programming Characteristics . . . . .	152
15.14	SIOPTiming ( $V_{DD} = 5.0$ Vdc) . . . . .	153
15.15	SIOPTiming ( $V_{DD} = 3.0$ Vdc) . . . . .	154
15.16	Reset Characteristics . . . . .	154

**Chapter 16**  
**Mechanical Specifications**

16.1	Introduction . . . . .	157
16.2	20-Pin Plastic Dual In-Line Package (Case 738) . . . . .	157
16.3	20-Pin Small Outline Integrated Circuit (Case 751D) . . . . .	158
16.4	28-Pin Plastic Dual In-Line Package (Case 710) . . . . .	158
16.5	28-Pin Small Outline Integrated Circuit (Case 751F) . . . . .	159
16.6	20-Pin Windowed Ceramic Integrated Circuit (Case 732) . . . . .	159
16.7	28-Pin Windowed Ceramic Integrated Circuit (Case 733A) . . . . .	160

**Chapter 17**  
**Ordering Information**

17.1	Introduction . . . . .	161
17.2	MC68HC705JJ7 Order Numbers . . . . .	161
17.3	MC68HC705JP7 Order Numbers . . . . .	162

# Chapter 1

## General Description

### 1.1 Introduction

The MC68HC705JJ7 and MC68HC705JP7 are erasable programmable read-only memory (EPROM) versions of the MC68HC05JJ/JP Family of microcontrollers (MCU).

### 1.2 Features

Features of the two parts include:

- Low-cost, M68HC05 core MCU in 20-pin package (MC68HC705JJ7) or 28-pin package (MC68HC705JP7)
- 6160 bytes of user EPROM, including 16 bytes of user vectors
- 224 bytes of low-power user random-access memory (RAM)
- 64 bits of personality EPROM (serial access)
- 16-bit programmable timer with input capture and output compare
- 15-stage core timer, including 8-bit free-running counter and 4-stage selectable real-time interrupt generator
- Simple serial input/output port (SIOP) with interrupt capability
- Two voltage comparators, one of which can be combined with the 16-bit programmable timer to create a 4-channel, single-slope analog-to-digital (A/D) converter
- Output of voltage comparator can drive port pin PB4 directly under software control
- 14 input/output (I/O) lines (MC68HC705JJ7) or 22 I/O lines (MC68HC705JP7), including high-source/sink current capability on 6 I/O pins (MC68HC705JJ7) or 14 I/O pins (MC68HC705JP7)
- Programmable 8-bit mask option register (MOR) to select mask options found in read-only memory (ROM) based versions
- MOR selectable software programmable pulldowns on all I/O pins and keyboard scan interrupt on four I/O pins
- Software mask and request bit for IRQ interrupt with MOR selectable sensitivity on IRQ interrupt (edge- and level-sensitive or edge-only)
- On-chip oscillator with device option of crystal/ceramic resonator or resistor-capacitor (RC) operation and MOR selectable shunt resistor, 2 M $\Omega$  by design
- Internal oscillator for lower-power operation, approximately 100 kHz (500 kHz selected as device option)
- EPROM security bit<sup>(1)</sup> to aid in locking out access to programmable EPROM array
- MOR selectable computer operating properly (COP) watchdog system

---

1. No security feature is absolutely secure. However, Freescale's strategy is to make reading or copying the EPROM/OTPROM difficult for unauthorized users.

## General Description

- Power-saving stop and wait mode instructions (MOR selectable STOP conversion to halt and option for fast 16-cycle restart and power-on reset)
- On-chip temperature measurement diode
- MOR selectable reset module to reset central processor unit (CPU) in low-voltage conditions
- Illegal address reset
- Internal steering diode and pullup device on  $\overline{\text{RESET}}$  pin to  $V_{DD}$

## 1.3 Device Options

These device options are available:

- On-chip oscillator type: crystal/ceramic resonator connections or resistor-capacitor (RC) connections
- Nominal frequency of internal low-power oscillator: 100 or 500 kHz

### NOTE

*A line over a signal name indicates an active low signal. For example, RESET is active high and  $\overline{\text{RESET}}$  is active low.*

*Any reference to voltage, current, or frequency specified in the following sections will refer to the nominal values. The exact values and their tolerance or limits are specified in [Chapter 15 Electrical Specifications](#).*

Combinations of the various device options are specified by part number. Refer to [Table 1-1](#) and to [Chapter 17 Ordering Information](#) for specific ordering information.

**Table 1-1. Device Options by Part Number**

Part Number	Pin Count	Oscillator Type	Internal LPO Nominal Frequency (kHz)
MC68HC705JJ7	20	Crystal/resonator	100
MC68HC705JP7	28	Crystal/resonator	100
MC68HC705SJ7	20	Crystal/resonator	500
MC68HC705SP7	28	Crystal/resonator	500
MC68HRC705JJ7	20	Resistor-capacitor	100
MC68HRC705JP7	28	Resistor-capacitor	100

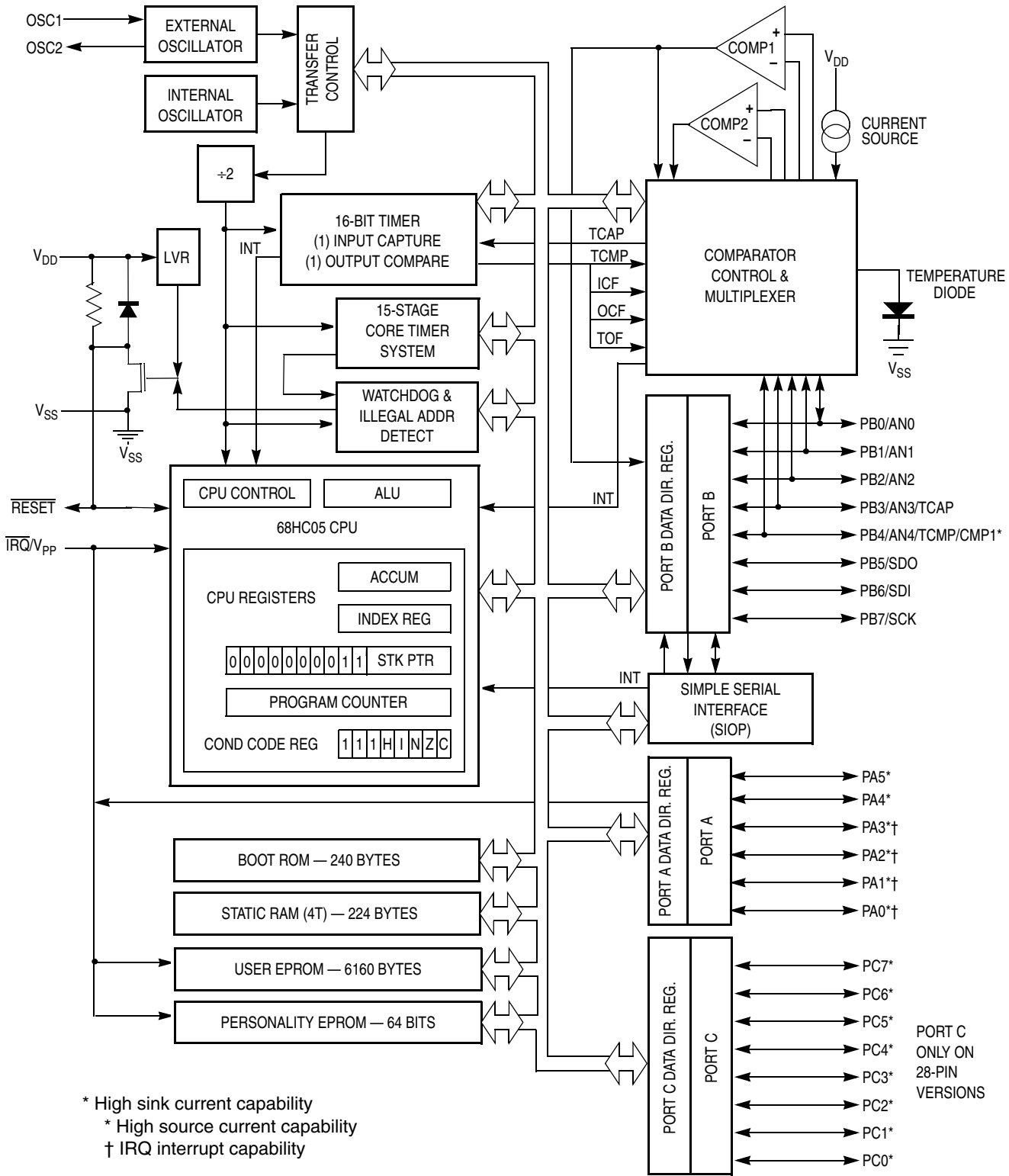
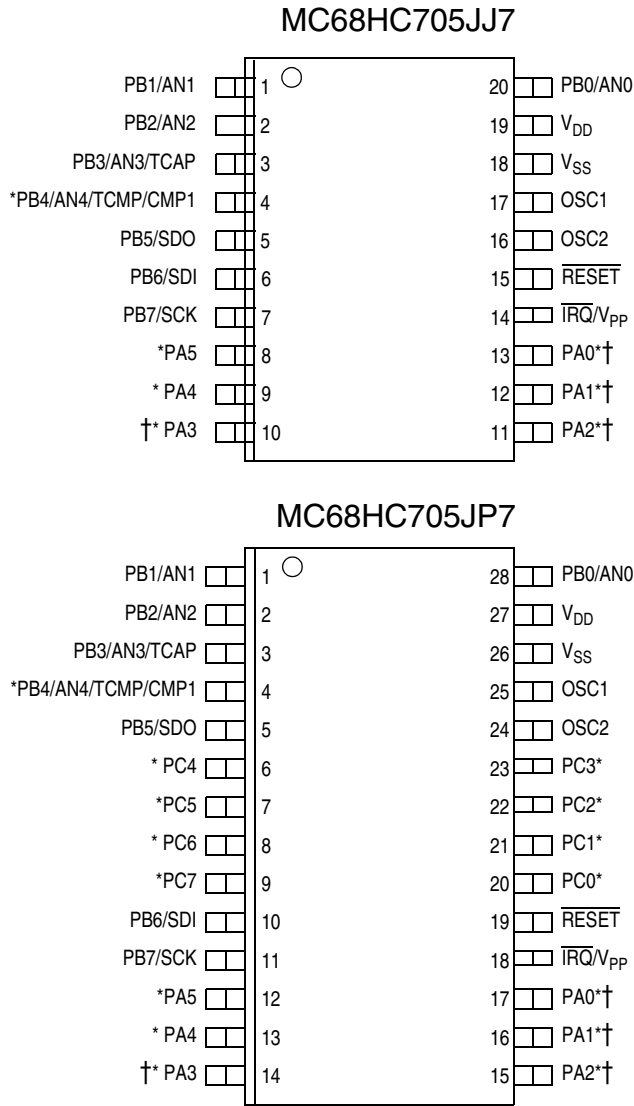

Figure 1-1. User Mode Block Diagram

## 1.4 Functional Pin Description

Refer to [Figure 1-2](#) for the pinouts of the MC68HC705JJ7 and MC68HC705JP7 in the user mode. The following paragraphs give a description of the general function of each pin.



\* Denotes 10 mA sink /5 mA source capability  
 † Denotes IRQ interrupt capability

**Figure 1-2. User Mode Pinouts**

## 1.5 V<sub>DD</sub> and V<sub>SS</sub> Pins

Power is supplied to the MCU through V<sub>DD</sub> and V<sub>SS</sub>. V<sub>DD</sub> is the positive supply, and V<sub>SS</sub> is ground. The MCU operates from a single power supply.

Very fast signal transitions occur on the MCU pins. The short rise and fall times place very high short-duration current demands on the power supply. To prevent noise problems, special care should be taken to provide good power supply bypassing at the MCU by using bypass capacitors with good high-frequency characteristics that are positioned as close to the MCU as possible.

## 1.6 OSC1 and OSC2 Pins

The OSC1 and OSC2 pins are the connections for the external pin oscillator (EPO). The OSC1 and OSC2 pins can accept these sets of components:

- A crystal as shown in [Figure 1-3 \(a\)](#)
- A ceramic resonator as shown in [Figure 1-3 \(a\)](#)
- An external resistor as shown in [Figure 1-3 \(b\)](#)
- An external clock signal as shown in [Figure 1-3 \(c\)](#)

The selection of the crystal/ceramic resonator or RC oscillator configuration is done by product part number selection as described in [Chapter 17 Ordering Information](#).

The frequency,  $f_{OSC}$ , of the EPO or external clock source is divided by two to produce the internal operating frequency,  $f_{OP}$ .

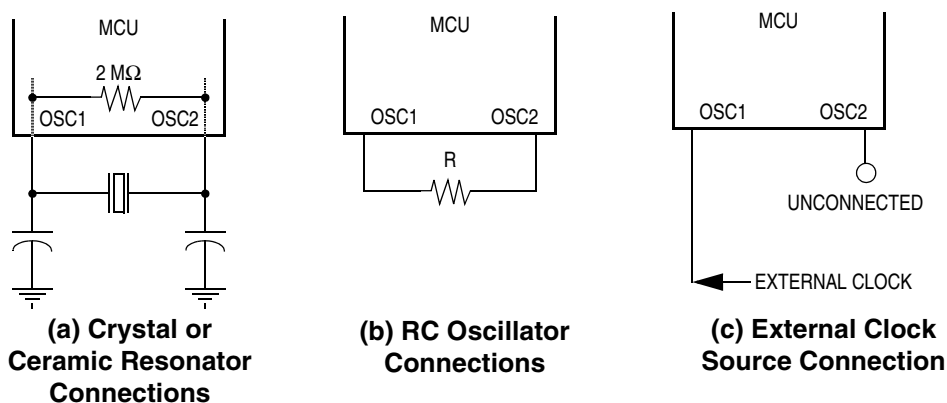

Figure 1-3. EPO Oscillator Connections

### 1.6.1 Crystal Oscillator

The circuit in [Figure 1-3 \(a\)](#) shows a typical oscillator circuit for an AT-cut, parallel resonant crystal. The crystal manufacturer's recommendations should be followed, as the crystal parameters determine the external component values required to provide maximum stability and reliable startup. The load capacitance values used in the oscillator circuit design should include all stray capacitances. The crystal and components should be mounted as close as possible to the pins for startup stabilization and to minimize output distortion. An internal startup resistor of approximately 2 MΩ can be provided between OSC1 and OSC2 for the crystal type oscillator by use of the OSCRES bit in the MOR.

## 1.6.2 Ceramic Resonator Oscillator

In cost-sensitive applications, a ceramic resonator can be used in place of the crystal. The circuit in [Figure 1-3 \(a\)](#) can be used for a ceramic resonator. The resonator manufacturer's recommendations should be followed, as the resonator parameters determine the external component values required for maximum stability and reliable starting. The load capacitance values used in the oscillator circuit design should include all stray capacitances. The ceramic resonator and components should be mounted as close as possible to the pins for startup stabilization and to minimize output distortion. An internal startup resistor of approximately 2 M $\Omega$  can be provided between OSC1 and OSC2 for the ceramic resonator type oscillator by use of the OSCRES bit in the MOR.

## 1.6.3 RC Oscillator

The lowest cost oscillator is the RC oscillator configuration where a resistor is connected between the two oscillator pins as shown in [Figure 1-3 \(b\)](#).

The selection of the RC oscillator configuration is done by product part number selection as described in [Chapter 17 Ordering Information](#).

### NOTE

*Do not use the internal startup resistor between OSC1 and OSC2 for the RC-type oscillator.*

## 1.6.4 External Clock

An external clock from another CMOS-compatible device can be connected to the OSC1 input, with the OSC2 input not connected, as shown in [Figure 1-3 \(c\)](#). This oscillator can be selected via software. This configuration is possible regardless of whether the crystal/ceramic resonator or RC oscillator configuration is used.

### NOTE

*Do not use the internal startup resistor between OSC1 and OSC2 for the external clock.*

## 1.6.5 Internal Low-Power Oscillator

An internal low-power oscillator (LPO) is provided which is the default oscillator out of reset. When operating from this internal LPO, the other oscillator can be powered down by software to further conserve power.

The selection of the LPO configuration is done by product part number selection as described in [Chapter 17 Ordering Information](#).

## 1.7 $\overline{\text{RESET}}$ Pin

The  $\overline{\text{RESET}}$  pin can be used as an input to reset the MCU to a known startup state by pulling it to the low state. It also functions as an output to indicate that an internal COP watchdog, illegal address, or low-voltage reset has occurred. The  $\overline{\text{RESET}}$  pin contains a pullup device to allow the pin to be left disconnected without an external pullup resistor. The  $\overline{\text{RESET}}$  pin also contains a steering diode that, when the power is removed, will discharge to  $V_{DD}$  any charge left on an external capacitor connected between the  $\overline{\text{RESET}}$  pin and  $V_{SS}$ . The  $\overline{\text{RESET}}$  pin also contains an internal Schmitt trigger to improve its noise immunity as an input.

## 1.8 $\overline{\text{IRQ}}/\text{V}_{\text{PP}}$ Pin

The  $\overline{\text{IRQ}}/\text{V}_{\text{PP}}$  input pin drives the asynchronous IRQ interrupt function of the CPU. The IRQ interrupt function uses the LEVEL bit in the MOR to provide either negative edge-sensitive triggering or both negative edge-sensitive and low level-sensitive triggering. If the LEVEL bit is set to enable level-sensitive triggering, the  $\overline{\text{IRQ}}/\text{V}_{\text{PP}}$  pin requires an external resistor to V<sub>DD</sub> for “wired-OR” operation. If the  $\overline{\text{IRQ}}/\text{V}_{\text{PP}}$  pin is not used, it must be tied to the V<sub>DD</sub> supply. The  $\overline{\text{IRQ}}/\text{V}_{\text{PP}}$  pin contains an internal Schmitt trigger as part of its input to improve noise immunity.

The voltage on this pin may affect operation if the voltage on the  $\overline{\text{IRQ}}/\text{V}_{\text{PP}}$  pin is above V<sub>DD</sub> when the device is released from a reset condition. The  $\overline{\text{IRQ}}/\text{V}_{\text{PP}}$  pin should only be taken above V<sub>DD</sub> to program an EPROM memory location or personality EPROM bit. For more information, refer to [15.13 PEPROM and EPROM Programming Characteristics](#).

### NOTE

*Each of the PA0–PA3 I/O pins may be connected as an OR function with the IRQ interrupt function by the PIRQ bit in the MOR. This capability allows keyboard scan applications where the transitions or levels on the I/O pins will behave the same as the  $\overline{\text{IRQ}}/\text{V}_{\text{PP}}$  pin, except that active transitions and levels are inverted. The edge or level sensitivity selected by the LEVEL bit in the MOR for the  $\overline{\text{IRQ}}/\text{V}_{\text{PP}}$  pin also applies to the I/O pins that are ORed to create the IRQ signal. For more information, refer to [4.5 External Interrupts](#).*

## 1.9 PA0–PA5

These six I/O lines comprise port A, a general-purpose bidirectional I/O port. This port also has four pins which have keyboard interrupt capability. All six of these pins have high current source and sink capability. All of these pins have software programmable pulldowns which can be disabled by the SWPDI bit in the MOR.

## 1.10 PB0–PB7

These eight I/O lines comprise port B, a general-purpose bidirectional I/O port. This port is also shared with the 16-bit programmable timer input capture and output compare functions, with the two voltage comparators in the analog subsystem, and with the simple serial interface (SIOP).

The outputs of voltage comparator 1 can directly drive the PB4 pin; and the PB4 pin has high current source and sink capability.

All of these pins have software programmable pulldowns which can be disabled by the SWPDI bit in the MOR.

## 1.11 PC0–PC7 (MC68HC705JP7)

These eight I/O lines comprise port C, a general-purpose bidirectional I/O port. This port is only available on the 28-pin MC68HC705JP7. All eight of these pins have high current source and sink capability.

All of these pins have software programmable pulldowns which can be disabled by the SWPDI bit in the MOR.



# Chapter 2

## Memory

### 2.1 Introduction

This section describes the organization of the memory on the MC68HC705JJ7/MC68HC705JP7.

### 2.2 Memory Map

The central processor unit (CPU) can address 8 kilobytes of memory space as shown in [Figure 2-1](#). The memory map includes:

- The erasable programmable read-only memory (EPROM) portion of memory holds the program instructions, fixed data, user-defined vectors, and interrupt service routines.
- The random-access memory (RAM) portion of memory holds variable data.
- Input/output (I/O) registers are memory mapped so that the CPU can access their locations in the same way that it accesses all other memory locations.

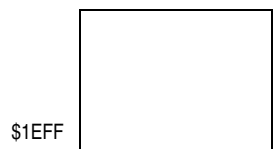

**Figure 2-1. Memory Map**

### 2.3 Input/Output Registers

[Figure 2-2](#) and [Figure 2-3](#) summarize:

- The first 32 addresses of the memory space, \$0000–\$001F, containing the I/O registers section
- One I/O register located outside the 32-byte I/O section, which is the computer operating properly register (COPR) mapped at \$1FF0

Address	Register Name
\$0000	Port A Data Register
\$0001	Port B Data Register
\$0002	Port C Data Register *
\$0003	Analog MUX Register
\$0004	Port A Data Direction Register
\$0005	Port B Data Direction Register
\$0006	Port C Data Direction Register *
\$0007	Unused
\$0008	Core Timer Status & Control Register
\$0009	Core Timer Counter
\$000A	Serial Control Register
\$000B	Serial Status Register
\$000C	Serial Data Register
\$000D	IRQ Status & Control Register
\$000E	Personality EPROM Bit Select Register
\$000F	Personality EPROM Status & Control Register
\$0010	Port A and Port C Pulldown Register *
\$0011	Port B Pulldown Register
\$0012	Timer Control Register
\$0013	Timer Status Register
\$0014	Input Capture Register (MSB)
\$0015	Input Capture Register (LSB)
\$0016	Output Compare Register (MSB)
\$0017	Output Compare Register (LSB)
\$0018	Timer Counter Register (MSB)
\$0019	Timer Counter Register (LSB)
\$001A	Alternate Counter Register (MSB)
\$001B	Alternate Counter Register (LSB)
\$001C	EPROM Programming Register
\$001D	Analog Control Register
\$001E	Analog Status Register
\$001F	Reserved

\* Features related to port C are only available on the 28-pin MC68HC705JP7 devices.

**Figure 2-2. I/O Registers**

Addr.	Register		Bit 7	6	5	4	3	2	1	Bit 0	
\$0000	Port A Data Register (PORTA) <a href="#">See page 55.</a>	Read:	0	0	PA5	PA4	PA3	PA2	PA1	PA0	
		Write:									
		Reset:	Unaffected by reset								
\$0001	Port B Data Register (PORTB) <a href="#">See page 58.</a>	Read:	PB7	PB6	PB5	PB4	PB3	PB2	PB1	PB0	
		Write:									
		Reset:	Unaffected by reset								
\$0002	Port C <sup>(1)</sup> Data Register (PORTC) <a href="#">See page 67.</a>	Read:	PC7	PC6	PC5	PC4	PC3	PC2	PC1	PC0	
		Write:									
		Reset:	Unaffected by reset								
\$0003	Analog Multiplex Register (AMUX) <a href="#">See page 73.</a>	Read:	HOLD	DHOLD	INV	VREF	MUX4	MUX3	MUX2	MUX1	
		Write:									
		Reset:	1	0	0	0	0	0	0	0	0
\$0004	Data Direction Register A (DDRA) <a href="#">See page 56.</a>	Read:	0	0	DDRA5	DDRA4	DDRA3	DDRA2	DDRA1	DDRA0	
		Write:									
		Reset:	0	0	0	0	0	0	0	0	0
\$0005	Data Direction Register B (DDRB) <a href="#">See page 59.</a>	Read:	DDRB7	DDRB6	DDRB5	DDRB4	DDRB3	DDRB2	DDRB1	DDRB0	
		Write:									
		Reset:	0	0	0	0	0	0	0	0	0
\$0006	Data Direction Register C (DDRC) <a href="#">See page 67.</a>	Read:	DDRC7	DDRC6	DDRC5	DDRC4	DDRC3	DDRC2	DDRC1	DDRC0	
		Write:									
		Reset:	0	0	0	0	0	0	0	0	0
\$0007	Unimplemented										
\$0008	Core Timer Status and Control Register (CTSCR) <a href="#">See page 102.</a>	Read:	CTOF	RTIF	CTOFE	RTIE	0	0	RT1	RT0	
		Write:					CTOFR	RTIFR			
		Reset:	0	0	0	0	0	0	1	1	
\$0009	Core Timer Counter Register (CTCR) <a href="#">See page 103.</a>	Read:	Bit 7	6	5	4	3	2	1	Bit 0	
		Write:									
		Reset:	0	0	0	0	0	0	0	0	0
\$000A	SIOP Control Register (SCR) <a href="#">See page 97.</a>	Read:	SPIE	SPE	LSBF	MSTR	0	CPHA	SPR1	SPR0	
		Write:					SPIR				
		Reset:	0	0	0	0	0	0	0	0	
\$000B	SIOP Status Register (SSR) <a href="#">See page 99.</a>	Read:	SPIF	DCOL	0	0	0	0	0	0	
		Write:									
		Reset:	0	0	0	0	0	0	0	0	

  = Unimplemented     
 R = Reserved     
 U = Unaffected

1. Features related to port C are only available on the 28-pin MC68HC705JP7 devices.

**Figure 2-3. Register Summary (Sheet 1 of 3)**

## Memory

Addr.	Register		Bit 7	6	5	4	3	2	1	Bit 0	
\$000C	SIOF Data Register (SDR) <a href="#">See page 100.</a>	Read:									
		Write:	Bit 7	6	5	4	3	2	1	Bit 0	
		Reset:									
\$000D	IRQ Status and Control Register (ISCR) <a href="#">See page 38.</a>	Read:	IRQE	OM2	OM1	0	IRQF	0	0	0	
		Write:				R			IRQR		
		Reset:	1	1	0	0	0	0	U	0	
\$000E	PEPROM Bit Select Register (PEBSR) <a href="#">See page 116.</a>	Read:	PEB7	PEB6	PEB5	PEB4	PEB3	PEB2	PEB1	PEB0	
		Write:									
		Reset:	0	0	0	0	0	0	0	0	0
\$000F	PEPROM Status and Control Register (PESCR) <a href="#">See page 116.</a>	Read:	PEDATA	0	PEPGM	0	0	0	0	PEPRZF	
		Write:					R	R	R		
		Reset:	U	0	0	0	0	0	0	0	1
\$0010	Pulldown Register Port A and Port C <sup>(1)</sup> (PDRA) <a href="#">See page 56.</a>	Read:									
		Write:	PDICH	PDICL	PDIA5	PDIA4	PDIA3	PDIA2	PDIA1	PDIA0	
		Reset:	0	0	0	0	0	0	0	0	0
\$0011	Pulldown Register B (PDRB) <a href="#">See page 59.</a>	Read:									
		Write:	PDIB7	PDIB6	PDIB5	PDIB4	PDIB3	PDIB2	PDIB1	PDIB0	
		Reset:	0	0	0	0	0	0	0	0	0
\$0012	Timer Control Register (TCR) <a href="#">See page 112.</a>	Read:	ICIE	OCIE	TOIE	0	0	0	IEDG	OLVL	
		Write:									
		Reset:	0	0	0	0	0	0	U	0	0
\$0013	Timer Status Register (TSR) <a href="#">See page 113.</a>	Read:	ICF	OCF	TOF	0	0	0	0	0	
		Write:									
		Reset:	U	U	U	0	0	0	0	0	0
\$0014	Input Capture Register High (ICRH) <a href="#">See page 110.</a>	Read:	Bit 15	14	13	12	11	10	9	Bit 8	
		Write:									
		Reset:	Unaffected by reset								
\$0015	Input Capture Register Low (ICRL) <a href="#">See page 110.</a>	Read:	Bit 7	6	5	4	3	2	1	Bit 0	
		Write:									
		Reset:	Unaffected by reset								
\$0016	Output Compare Register High (OCRH) <a href="#">See page 111.</a>	Read:	Bit 15	14	13	12	11	10	9	Bit 8	
		Write:									
		Reset:	Unaffected by reset								
\$0017	Output Compare Register Low (OCRL) <a href="#">See page 111.</a>	Read:	Bit 7	6	5	4	3	2	1	Bit 0	
		Write:									
		Reset:	Unaffected by reset								

= Unimplemented   
R = Reserved   
U = Unaffected

1. Features related to port C are only available on the 28-pin MC68HC705JP7 devices.

**Figure 2-3. Register Summary (Sheet 2 of 3)**

Addr.	Register		Bit 7	6	5	4	3	2	1	Bit 0	
\$0018	Programmable Timer Register High (TMRH) <a href="#">See page 107.</a>	Read:	Bit 15	14	13	12	11	10	9	Bit 8	
		Write:									
		Reset:	1	1	1	1	1	1	1	1	1
\$0019	Programmable Timer Register Low (TMRL) <a href="#">See page 107.</a>	Read:	Bit 7	6	5	4	3	2	1	Bit 0	
		Write:									
		Reset:	1	1	1	1	1	1	0	0	0
\$001A	Alternate Counter Register High (ACRH) <a href="#">See page 108.</a>	Read:	Bit 15	14	13	12	11	10	9	Bit 8	
		Write:									
		Reset:	1	1	1	1	1	1	1	1	1
\$001B	Alternate Counter Register Low (ACRL) <a href="#">See page 108.</a>	Read:	Bit 15	14	13	12	11	10	9	Bit 8	
		Write:									
		Reset:	1	1	1	1	1	1	0	0	0
\$001C	EPROM Programming Register (EPROG) <a href="#">See page 119.</a>	Read:	0	0	0	0	0	ELAT	MPGM	EPGM	
		Write:		R	R	R	R				
		Reset:	0	0	0	0	0	0	0	0	0
\$001D	Analog Counter Register (ACR) <a href="#">See page 77.</a>	Read:	CHG	ATD2	ATD1	ICEN	CPIE	CP2EN	CP1EN	ISEN	
		Write:									
		Reset:	0	0	0	0	0	0	0	0	0
\$001E	Analog Status Register (ASR) <a href="#">See page 77.</a>	Read:	CPF2	CPF1	0	0	COE1	VOFF	CMP2	CMP1	
		Write:			CPFR2	CPFR1					
		Reset:	0	0	0	0	0	0	0	0	0
\$001F	Reserved		R	R	R	R	R	R	R	R	
↓											
\$1FEF	Reserved		R	R	R	R	R	R	R	R	
\$1FF0	COP and Security Register (COPR) <a href="#">See pages 27, 92, 104, and 122.</a>	Read:		OPT							
		Write:	EPMSEC							COPC	
		Reset:			Unaffected by reset						

  = Unimplemented    
 R = Reserved    
 U = Unaffected

1. Features related to port C are only available on the 28-pin MC68HC705JP7 devices.

**Figure 2-3. Register Summary (Sheet 3 of 3)**

## 2.4 User and Interrupt Vector Mapping

The interrupt vectors are contained in the upper memory addresses above \$1FF0 as shown in [Figure 2-4](#).

Address	Register Name
\$1FF0	COP Register and EPROM Security
\$1FF1	Mask Option Register
\$1FF2	Analog Interrupt Vector (MSB)
\$1FF3	Analog Interrupt Vector (LSB)
\$1FF4	Serial Interrupt Vector (MSB)
\$1FF5	Serial Interrupt Vector (LSB)
\$1FF6	Timer Interrupt Vector (MSB)
\$1FF7	Timer Interrupt Vector (LSB)
\$1FF8	Core Timer Interrupt Vector (MSB)
\$1FF9	Core Timer Interrupt Vector (LSB)
\$1FFA	External IRQ Vector (MSB)
\$1FFB	External IRQ Vector (LSB)
\$1FFC	SWI Vector (MSB)
\$1FFD	SWI Vector (LSB)
\$1FFE	Reset Vector (MSB)
\$1FFF	Reset Vector (LSB)

**Figure 2-4. Vector Mapping**

## 2.5 Random-Access Memory (RAM)

The 224 addresses from \$0020 to \$00FF serve as both the user RAM and the stack RAM. The central processor unit (CPU) uses five RAM bytes to save all CPU register contents before processing an interrupt. During a subroutine call, the CPU uses two bytes to store the return address. The stack pointer decrements during pushes and increments during pulls.

**NOTE**

*Be careful when using nested subroutines or multiple interrupt levels. The CPU may overwrite data in the RAM during a subroutine or during the interrupt stacking operation.*

## 2.6 Erasable Programmable Read-Only Memory (EPROM)

The EPROM is located in three areas of the memory map:

- Addresses \$0700–\$1EFF contain 6144 bytes of user EPROM.
- Addresses \$1FF0–\$1FF1 contain 2 bytes of EPROM reserved for user vectors and COP and security register (COPR), and the mask option register. Only bit 7 of \$1FF0 is a programmable bit.
- Addresses \$1FF2–\$1FFF contain 14 bytes of interrupt vectors.

## 2.7 COP Register

As shown in [Figure 2-5](#), a register location is provided at \$1FF0 to set the EPROM security<sup>(1)</sup>, select the optional features, and reset the COP watchdog timer. The OPT bit controls the function of the PB4 port pin and the availability to add an offset to any measured analog voltages. See [8.4 Analog Status Register](#) for more information

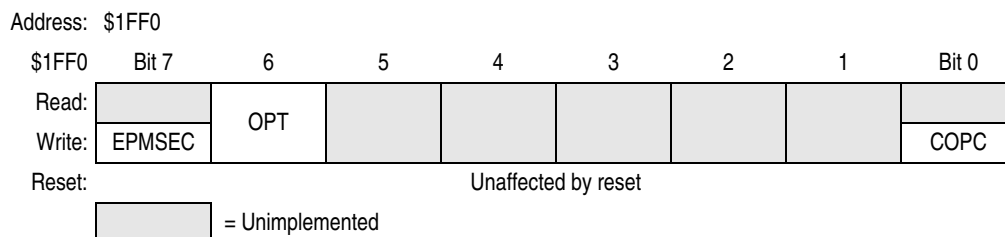

**Figure 2-5. COP and Security Register (COPR)**

1. No security feature is absolutely secure. However, Freescale’s strategy is to make reading or copying the EPROM/OTPROM difficult for unauthorized users.



# Chapter 3

## Central Processor Unit (CPU)

### 3.1 Introduction

This section describes the central processor unit (CPU) registers. [Figure 3-1](#) shows the five CPU registers. CPU registers are not part of the memory map.

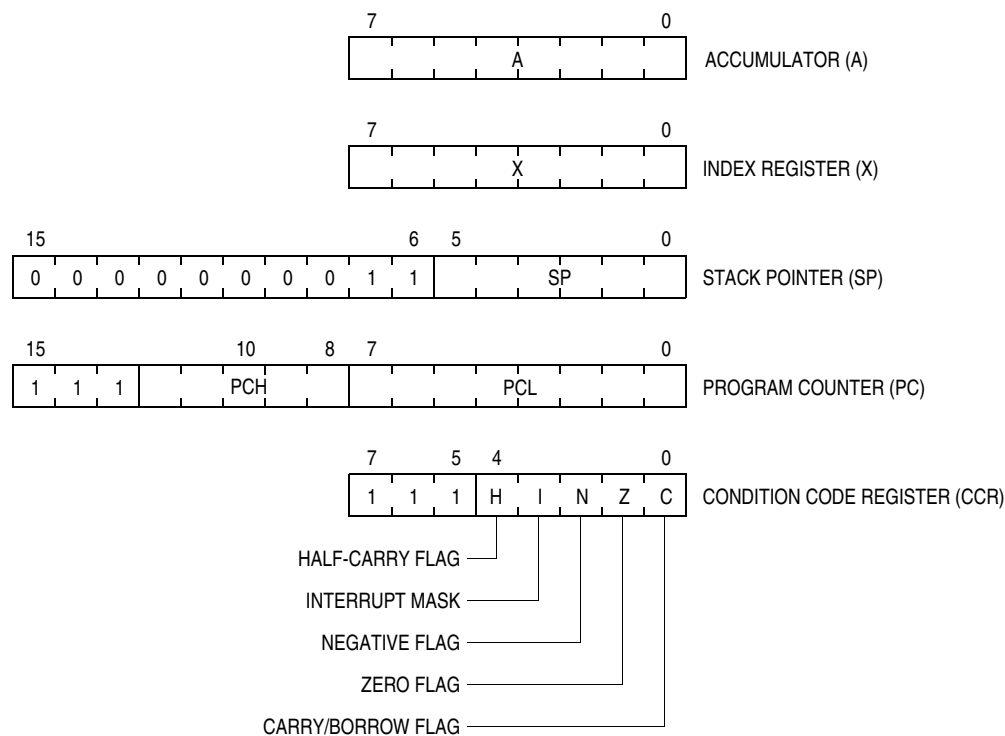

**Figure 3-1. M68HC05 Programming Model**

### 3.2 Accumulator

The accumulator is a general-purpose 8-bit register as shown in [Figure 3-2](#). The CPU uses the accumulator to hold operands and results of arithmetic and non-arithmetic operations.

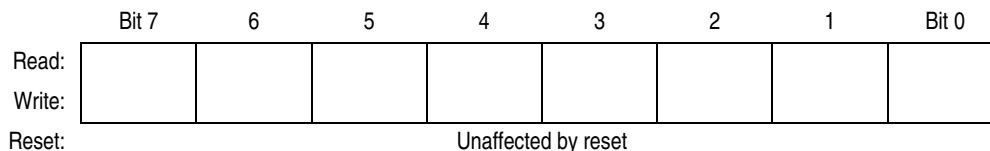

**Figure 3-2. Accumulator (A)**

### 3.3 Index Register

The index register is a general-purpose 8-bit register as shown in Figure 3-3. In the indexed addressing modes, the CPU uses the byte in the index register to determine the conditional address of the operand. The 8-bit index register can also serve as a temporary data storage location.

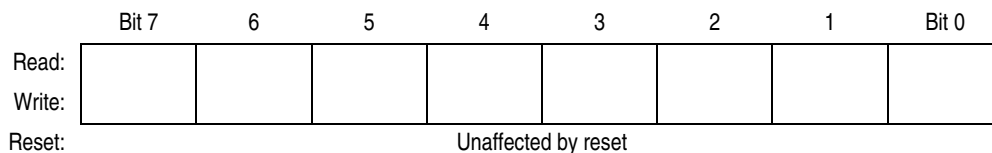

Figure 3-3. Index Register (X)

### 3.4 Stack Pointer

The stack pointer is a 16-bit register that contains the address of the next location on the stack as shown in Figure 3-4. During a reset or after the reset stack pointer (RSP) instruction, the stack pointer initializes to \$00FF. The address in the stack pointer decrements as data is pushed onto the stack and increments as data is pulled from the stack.

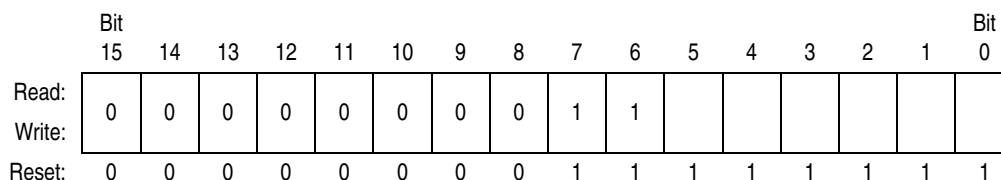

Figure 3-4. Stack Pointer (SP)

The 10 most significant bits of the stack pointer are permanently fixed at 000000011, so the stack pointer produces addresses from \$00C0 to \$00FF. If subroutines and interrupts use more than 64 stack locations, the stack pointer wraps around to address \$00FF and begins writing over the previously stored data. A subroutine uses two stack locations; an interrupt uses five locations.

### 3.5 Program Counter

The program counter is a 16-bit register that contains the address of the next instruction or operand to be fetched as shown in Figure 3-5. The three most significant bits of the program counter are ignored internally and appear as 111 during stacking and subroutine calls.

Normally, the address in the program counter automatically increments to the next sequential memory location every time an instruction or operand is fetched. Jump, branch, and interrupt operations load the program counter with an address other than that of the next sequential location.

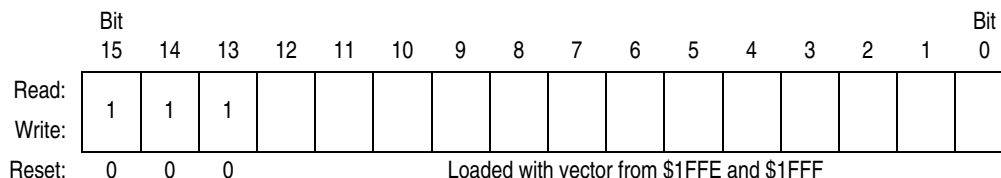

Figure 3-5. Program Counter (PC)

## 3.6 Condition Code Register

The condition code register is an 8-bit register whose three most significant bits are permanently fixed at 111 as shown in Figure 3-6. The condition code register contains the interrupt mask and four flags that indicate the results of the instruction just executed. The following paragraphs describe the functions of the condition code register.

	Bit 7	6	5	4	3	2	1	Bit 0
Read:	1	1	1	H	I	N	C	Z
Write:	1	1	1	H	I	N	C	Z
Reset:	1	1	1	U	1	U	U	U

U = Unaffected

**Figure 3-6. Condition Code Register (CCR)**

### Half-Carry Flag (H)

The CPU sets the half-carry flag when a carry occurs between bits 3 and 4 of the accumulator during an ADD or ADC operation. The half-carry flag is required for binary coded decimal (BCD) arithmetic operations. Reset has no effect on the half-carry flag.

### Interrupt Mask (I)

Setting the interrupt mask disables interrupts. If an interrupt request occurs while the interrupt mask is a logic 0, the CPU saves the CPU registers on the stack, sets the interrupt mask, and then fetches the interrupt vector. If an interrupt request occurs while the interrupt mask is set, the interrupt request is latched. The CPU processes the latched interrupt as soon as the interrupt mask is cleared again. A return-from-interrupt (RTI) instruction pulls the CPU registers from the stack, restoring the interrupt mask to its cleared state. After a reset, the interrupt mask is set and can be cleared only by a CLI instruction.

### Negative Flag (N)

The CPU sets the negative flag when an arithmetic operation, logical operation, or data manipulation produces a negative result. Reset has no effect on the negative flag.

### Zero Flag (Z)

The CPU sets the zero flag when an arithmetic operation, logical operation, or data manipulation produces a result of \$00. Reset has no effect on the zero flag.

### Carry/Borrow Flag (C)

The CPU sets the carry/borrow flag when an addition operation produces a carry out of bit 7 of the accumulator or when a subtraction operation requires a borrow. Some logical operations and data manipulation instructions also clear or set the carry/borrow flag. Reset has no effect on the carry/borrow flag.

## 3.7 Arithmetic/Logic Unit (ALU)

The ALU performs the arithmetic and logical operations defined by the instruction set. The binary arithmetic circuits decode instructions and set up the ALU for the selected operation. Most binary arithmetic is based on the addition algorithm, carrying out subtraction as negative addition. Multiplication is not performed as a discrete operation but as a chain of addition and shift operations within the ALU. The multiply instruction (MUL) requires 11 internal clock cycles to complete this chain of operations.



# Chapter 4 Interrupts

## 4.1 Introduction

An interrupt temporarily stops normal program execution to process a particular event. An interrupt does not stop the execution of the instruction in progress, but takes effect when the current instruction completes its execution. Interrupt processing automatically saves the central processor unit (CPU) registers on the stack and loads the program counter with a user-defined vector address.

## 4.2 Interrupt Vectors

Table 4-1 summarizes the reset and interrupt sources and vector assignments.

**NOTE**

*If more than one interrupt request is pending, the CPU fetches the vector of the higher priority interrupt first. A higher priority interrupt does not actually interrupt a lower priority interrupt service routine unless the lower priority interrupt service routine clears the I bit.*

**Table 4-1. Reset/Interrupt Vector Addresses**

Function	Source	MOR Control Bit	Global Hardware Mask	Local Software Mask	Priority (1 = Highest)	Vector Address
Reset	Power-on logic RESET pin Low-voltage reset Illegal address reset	—	—	—	1	\$1FFE–\$1FFF
	COP watchdog	COPEN <sup>(1)</sup>				
Software interrupt (SWI)	User code	—	—	—	Same priority as instruction	\$1FFC–\$1FFD
External interrupt (IRQ)	IRQ/V <sub>PP</sub> pin	—	I bit	IRQE bit	2	\$1FFA–\$1FFB
	PA3 pin PA2 pin PA1 pin PA0 pin	PIRQ <sup>(2)</sup>				
Core timer interrupts	TOF bit RTIF bit	—	I bit	TOFE bit RTIE bit	3	\$1FF8–\$1FF9
Programmable timer interrupts	ICF bit OCF bit TOF bit	—	I bit	ICIE bit OCIE bit TOIE bit	4	\$1FF6–\$1FF7
Serial interrupt	SPIF bit	—	I bit	SPIE bit	5	\$1FF4–\$1FF5
Analog interrupt	CPF1 bit CPF2 bit	—	I bit	CPIE bit	6	\$1FF2–\$1FF3

1. COPEN enables the COP watchdog timer.

2. PIRQ enables port A external interrupts on PA0–PA3.

### 4.3 Interrupt Processing

To begin servicing an interrupt, the CPU does these actions:

- Stores the CPU registers on the stack in the order shown in [Figure 4-1](#)
- Sets the I bit in the condition code register to prevent further interrupts
- Loads the program counter with the contents of the appropriate interrupt vector locations as shown in [Table 4-1](#)

The return-from-interrupt (RTI) instruction causes the CPU to recover its register contents from the stack as shown in [Figure 4-1](#). The sequence of events caused by an interrupt is shown in the flowchart in [Figure 4-2](#).

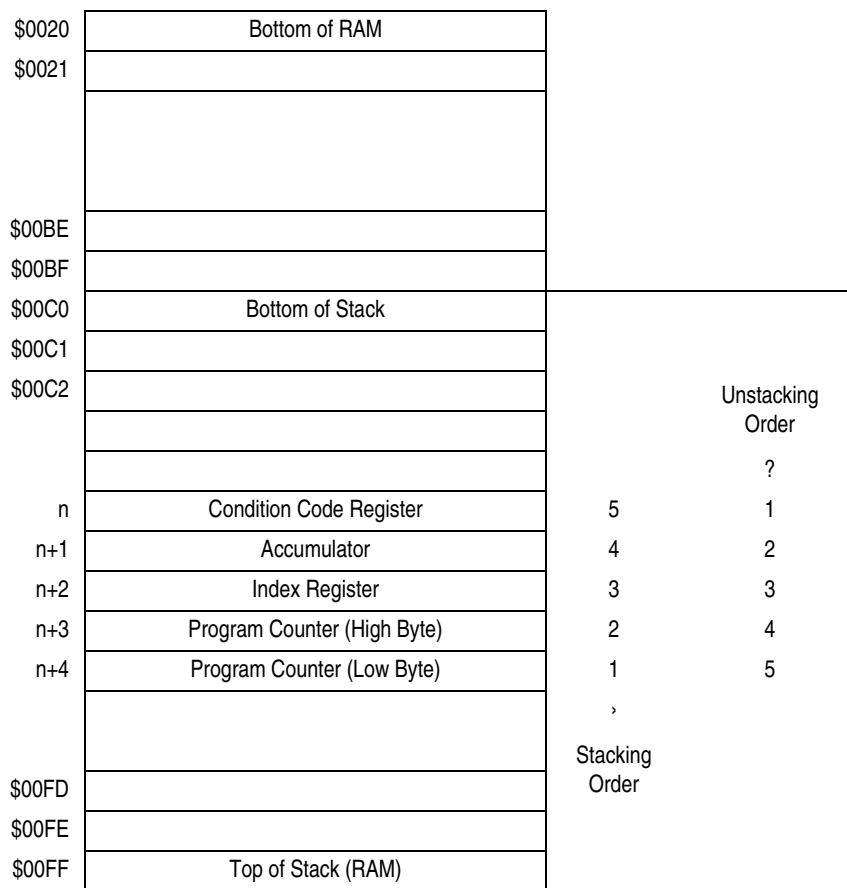

**Figure 4-1. Interrupt Stacking Order**

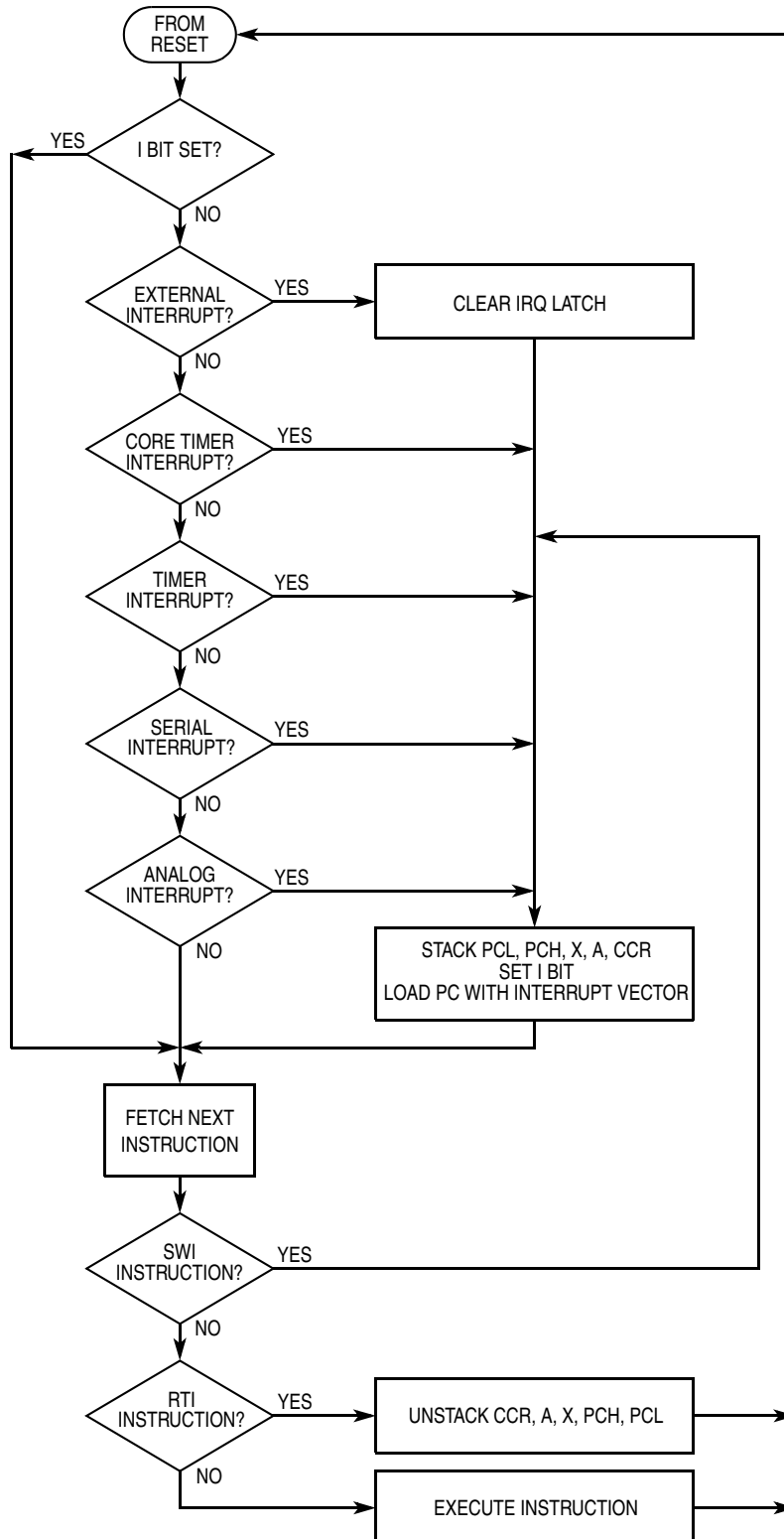

**Figure 4-2. Interrupt Flowchart**

## 4.4 Software Interrupt

The software interrupt (SWI) instruction causes a non-maskable interrupt.

## 4.5 External Interrupts

These sources can generate external interrupts:

- $\overline{\text{IRQ}}/V_{PP}$  pin
- PA3–PA0 pins

Setting the I bit in the condition code register or clearing the IRQE bit in the interrupt status and control register disables these external interrupts.

### 4.5.1 $\overline{\text{IRQ}}/V_{PP}$ Pin

An interrupt signal on the  $\overline{\text{IRQ}}/V_{PP}$  pin latches an external interrupt request. To help clean up slow edges, the input from the  $\overline{\text{IRQ}}/V_{PP}$  pin is processed by a Schmitt trigger gate. When the CPU completes its current instruction, it tests the IRQ latch. If the IRQ latch is set, the CPU then tests the I bit in the condition code register and the IRQE bit in the IRQ status and control register (ISCR). If the I bit is clear and the IRQE bit is set, then the CPU begins the interrupt sequence. The CPU clears the IRQ latch while it fetches the interrupt vector, so that another external interrupt request can be latched during the interrupt service routine. As soon as the I bit is cleared during the return from interrupt, the CPU can recognize the new interrupt request. [Figure 4-3](#) shows the logic for external interrupts.

#### **NOTE**

*If the  $\overline{\text{IRQ}}/V_{PP}$  pin is not in use, it should be connected to the  $V_{DD}$  pin.*

The  $\overline{\text{IRQ}}/V_{PP}$  pin can be negative edge-triggered only or negative edge- and low level-triggered. External interrupt sensitivity is programmed with the LEVEL bit in the mask option register (MOR).

With the edge- and level-sensitive trigger MOR option, a falling edge or a low level on the  $\overline{\text{IRQ}}/V_{PP}$  pin latches an external interrupt request. The edge- and level-sensitive trigger MOR option allows connection to the  $\overline{\text{IRQ}}/V_{PP}$  pin of multiple wired-OR interrupt sources. As long as any source is holding the IRQ low, an external interrupt request is present, and the CPU continues to execute the interrupt service routine.

With the edge-sensitive-only trigger option, a falling edge on the  $\overline{\text{IRQ}}/V_{PP}$  pin latches an external interrupt request. A subsequent interrupt request can be latched only after the voltage level on the  $\overline{\text{IRQ}}/V_{PP}$  pin returns to a logic 1 and then falls again to logic 0.

#### **NOTE**

*The response of the  $\overline{\text{IRQ}}/V_{PP}$  pin can be affected if the external interrupt capability of the PA0 through PA3 pins is enabled. If the port A pins are enabled as external interrupts, then any high level on a PA0–PA3 pin will cause the IRQ changes and state to be ignored until all of the PA0–PA3 pins have returned to a low level.*

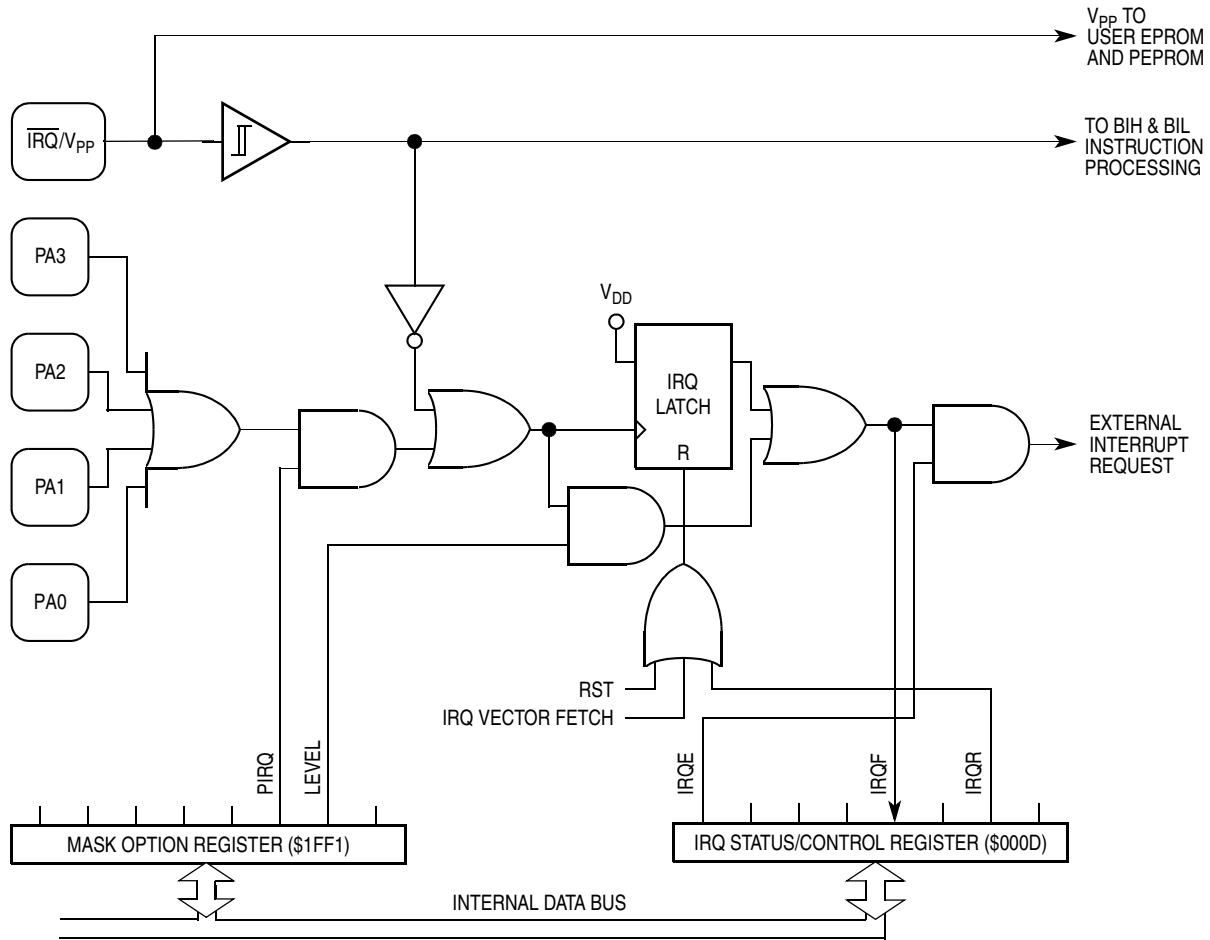

Figure 4-3. External Interrupt Logic

### 4.5.2 PA0–PA3 Pins

Programming the PIRQ bit in the MOR to a logic 1 enables the PA0–PA3 pins (PA0:3) to serve as additional external interrupt sources. A rising edge on a PA0:3 pin latches an external interrupt request. After completing the current instruction, the CPU tests the IRQ latch. If the IRQ latch is set, the CPU then tests the I bit in the condition code register and the IRQE bit in the ISCR. If the I bit is clear and the IRQE bit is set, the CPU then begins the interrupt sequence. The CPU clears the IRQ latch while it fetches the interrupt vector, so that another external interrupt request can be latched during the interrupt service routine. As soon as the I bit is cleared during the return from interrupt, the CPU can recognize the new interrupt request.

The PA0:3 pins can be edge-triggered or edge- and level-triggered. External interrupt triggering sensitivity is selected by the LEVEL bit in the MOR.

With the edge- and level-sensitive trigger MOR option, a rising edge or a high level on a PA0:3 pin latches an external interrupt request. The edge- and level-sensitive trigger MOR option allows connection to a PA0:3 pin of multiple wired-OR interrupt sources. As long as any source is holding the pin high, an external interrupt request is present, and the CPU continues to execute the interrupt service routine.

## Interrupts

With the edge-sensitive only trigger MOR option, a rising edge on a PA0:3 pin latches an external interrupt request. A subsequent external interrupt request can be latched only after the voltage level of the previous interrupt signal returns to a logic 0 and then rises again to a logic 1.

### NOTE

*If the port A pins are enabled as external interrupts, then a high level on any PA0:3 pin will drive the state of the IRQ function such that the  $\overline{IRQ}/V_{PP}$  pin and other PA0:3 pins are to be ignored until ALL of the PA0:3 pins have returned to a low level. Similarly, if the  $\overline{IRQ}/V_{PP}$  pin is at a low level, the PA0:3 pins will be ignored until the  $\overline{IRQ}/V_{PP}$  pin returns to a high state.*

### 4.5.3 IRQ Status and Control Register (ISCR)

The IRQ status and control register (ISCR), shown in Figure 4-4, contains an external interrupt mask (IRQE), an external interrupt flag (IRQF), and a flag reset bit (IRQR). Unused bits will read as logic 0s. The ISCR also contains two control bits for the oscillators, external pin oscillator, and internal low-power oscillator. Reset sets the IRQE and OM2 bits and clears all the other bits.

Address: \$000D

	Bit 7	6	5	4	3	2	1	Bit 0
Read:	IRQE	OM2	OM1	0	IRQF	0	0	0
Write:				R			IRQR	
Reset:	1	1	0	0	0	0	U	0

= Unimplemented     
 R = Reserved     
 U = Unaffected

**Figure 4-4. IRQ Status and Control Register (ISCR)**

#### IRQE — External Interrupt Request Enable Bit

This read/write bit enables external interrupts. Reset sets the IRQE bit.

- 1 = External interrupt processing enabled
- 0 = External interrupt processing disabled

#### OM1 and OM2 — Oscillator Select Bits

These bits control the selection and enabling of the oscillator source for the MCU. One choice is the internal low-power oscillator (LPO). The other choice is the external pin oscillator (EPO) which is common to most M68HC05 MCU devices. The EPO uses external components like filter capacitors and a crystal or ceramic resonator and consumes more power. The selection and enable conditions for these two oscillators are shown in Table 4-2.

**Table 4-2. Oscillator Selection**

OM2	OM1	Oscillator Selected by CPU	Internal Low-Power Oscillator (LPO)	External Pin Oscillator (EPO)	Power Consumption
0	0	Internal	Enabled	Disabled	Lowest
0	1	External	Disabled	Enabled	Normal
1	0	Internal	Enabled	Disabled	Lowest
1	1	Internal	Enabled	Enabled	Normal

Therefore, the lowest power is consumed when OM1 is cleared. The state with both OM1 and OM2 set is provided so that the EPO can be started and allowed to stabilize while the LPO still clocks the MCU. The reset state is for OM1 to be cleared and OM2 to be set, which selects the LPO and disables the EPO.

#### IRQF — External Interrupt Request Flag

The IRQ flag is a clearable, read-only bit that is set when an external interrupt request is pending. Writing to the IRQF bit has no effect. Reset clears the IRQF bit.

- 1 = Interrupt request pending
- 0 = No interrupt request pending

The following conditions set the IRQ flag:

- An external interrupt signal on the  $\overline{\text{IRQ}}/\text{V}_{\text{PP}}$  pin
- An external interrupt signal on pin PA0, PA1, PA2, or PA3 when the PA0–PA3 pins are enabled by the PIRQ bit in the MOR to serve as external interrupt sources.

The following conditions clear the IRQ flag:

- When the CPU fetches the interrupt vector
- When a logic 1 is written to the IRQR bit

#### IRQR — Interrupt Request Reset Bit

This write-only bit clears the IRQF flag bit and prevents redundant execution of interrupt routines. Writing a logic 1 to IRQR clears the IRQF. Writing a logic 0 to IRQR has no effect. IRQR always reads as a logic 0. Reset has no effect on IRQR.

- 1 = Clear IRQF flag bit
- 0 = No effect

## 4.6 Core Timer Interrupts

The core timer can generate the following interrupts:

- Timer overflow interrupt
- Real-time interrupt

Setting the I bit in the condition code register disables core timer interrupts. The controls and flags for these interrupts are in the core timer status and control register (CTSCR) located at \$0008.

### 4.6.1 Core Timer Overflow Interrupt

An overflow interrupt request occurs if the core timer overflow flag (TOF) becomes set while the core timer overflow interrupt enable bit (TOFE) is also set. The TOF flag bit can be reset by writing a logic 1 to the CTOFR bit in the CTSCR or by a reset of the device.

### 4.6.2 Real-Time Interrupt

A real-time interrupt request occurs if the real-time interrupt flag (RTIF) in the CTSCR becomes set while the real-time interrupt enable bit (RTIE) is also set. The RTIF flag bit can be reset by writing a logical 1 to the RTIFR bit in the CTSCR or by a reset of the device.

## 4.7 Programmable Timer Interrupts

The 16-bit programmable timer can generate an interrupt whenever the following events occur:

- Input capture
- Output compare
- Timer counter overflow

Setting the I bit in the condition code register disables timer interrupts. The controls for these interrupts are in the timer control register (TCR) located at \$0012 and in the status bits in the timer status register (TSR) located at \$0013.

### 4.7.1 Input Capture Interrupt

An input capture interrupt occurs if the input capture flag (ICF) becomes set while the input capture interrupt enable bit (ICIE) is also set. The ICF flag bit is in the TSR, and the ICIE enable bit is located in the TCR. The ICF flag bit is cleared by a read of the TSR with the ICF flag bit set, and then followed by a read of the LSB of the input capture register (ICRL) or by reset. The ICIE enable bit is unaffected by reset.

### 4.7.2 Output Compare Interrupt

An output compare interrupt occurs if the output compare flag (OCF) becomes set while the output compare interrupt enable bit (OCIE) is also set. The OCF flag bit is in the TSR and the OCIE enable bit is in the TCR. The OCF flag bit is cleared by a read of the TSR with the OCF flag bit set, and then followed by an access to the LSB of the output compare register (OCRL) or by reset. The OCIE enable bit is unaffected by reset.

### 4.7.3 Timer Overflow Interrupt

A timer overflow interrupt occurs if the timer overflow flag (TOF) becomes set while the timer overflow interrupt enable bit (TOIE) is also set. The TOF flag bit is in the TSR and the TOIE enable bit is in the TCR. The TOF flag bit is cleared by a read of the TSR with the TOF flag bit set, and then followed by an access to the LSB of the timer registers (TMRL) or by reset. The TOIE enable bit is unaffected by reset.

## 4.8 Serial Interrupts

The simple serial interface can generate the following interrupts:

- Receive sequence complete
- Transmit sequence complete

Setting the I bit in the condition code register disables serial interrupts. The controls for these interrupts are in the serial control register (SCR) located at \$000A and in the status bits in the serial status register (SSR) located at \$000B.

A transfer complete interrupt occurs if the serial interrupt flag (SPIF) becomes set while the serial interrupt enable bit (SPIE) is also set. The SPIF flag bit is in the serial status register (SSR) located at \$000B, and the SPIE enable bit is located in the serial control register (SCR) located at \$000A. The SPIF flag bit is cleared by a read of the SSR with the SPIF flag bit set, and then followed by a read or write to the serial data register (SDR) located at \$000C. The SPIF flag bit can also be reset by writing a one to the SPIR bit in the SCR.

## 4.9 Analog Interrupts

The analog subsystem can generate the following interrupts:

- Voltage on positive input of comparator 1 is greater than the voltage on the negative input of comparator 1.
- Voltage on positive input of comparator 2 is greater than the voltage on the negative input of comparator 2.
- Trigger of the input capture interrupt from the programmable timer as described in [4.7.1 Input Capture Interrupt](#)

Setting the I bit in the condition code register disables analog subsystem interrupts. The controls for these interrupts are in the analog subsystem control register (ACR) located at \$001D, and the status bits are in the analog subsystem status register (ASR) located at \$001E.

### 4.9.1 Comparator Input Match Interrupt

A comparator input match interrupt occurs if either compare flag bit (CPF1 or CPF2) in the ASR becomes set while the comparator interrupt enable bit (CPIE) in the ACR is also set. The CPF1 and CPF2 flag bits can be reset by writing a one to the corresponding CPFR1 or CPFR2 bits in the ASR. Reset clears these bits.

### 4.9.2 Input Capture Interrupt

The analog subsystem can also generate an input capture interrupt through the 16-bit programmable timer. The input capture can be triggered when there is a match in the input conditions for the voltage comparator 2. If comparator 2 sets the CP2F flag bit in the ASR and the input capture enable (ICEN) in the ACR is set, then an input capture will be performed by the programmable timer. If the ICIE enable bit in the TCR is also set, then an input compare interrupt will occur. Reset clears these bits.

#### **NOTE**

*For the analog subsystem to generate an interrupt using the input capture function of the programmable timer, the ICEN enable bit in the ACR, and the ICIE and IEDG bits in the TCR must all be set.*



# Chapter 5

## Resets

### 5.1 Introduction

This section describes the five reset sources and how they initialize the microcontroller unit (MCU). A reset immediately stops the operation of the instruction being executed, initializes certain control bits, and loads the program counter with a user-defined reset vector address. These conditions produce a reset:

- Initial power-up of device (power-on reset)
- A logic 0 applied to the  $\overline{\text{RESET}}$  pin (external reset)
- Timeout of the computer operating properly (COP) watchdog (COP reset)
- Low voltage applied to the device (LVR reset)
- Fetch of an opcode from an address not in the memory map (illegal address reset)

Figure 5-1 shows a block diagram of the reset sources and their interaction.

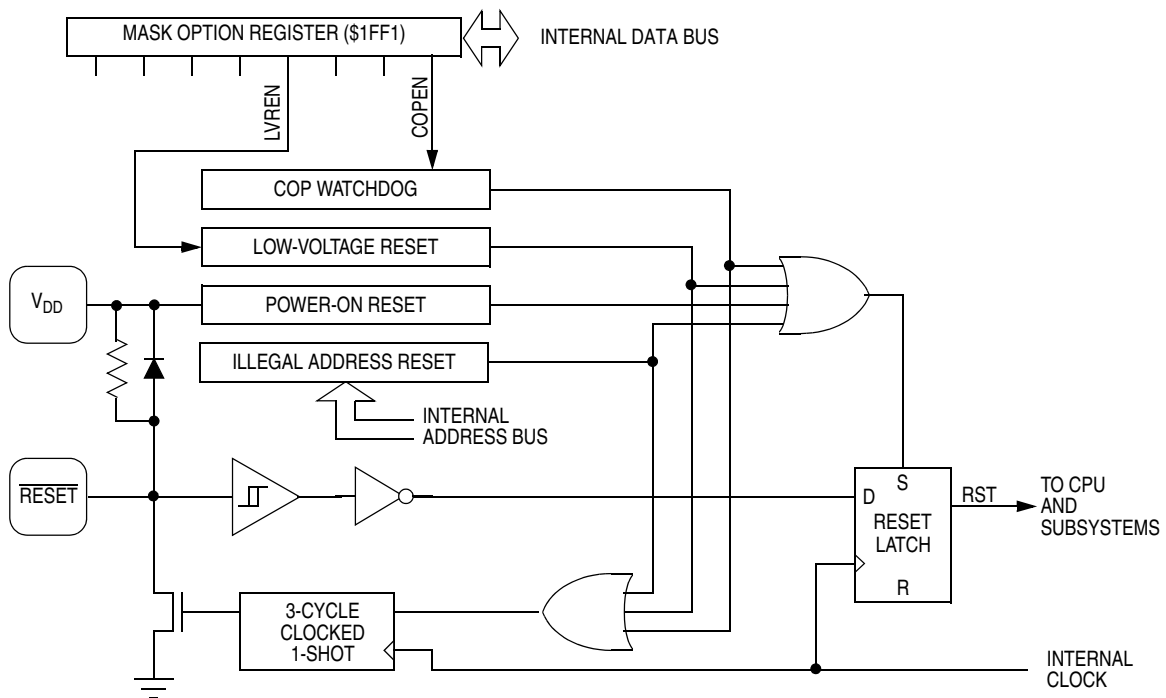

Figure 5-1. Reset Sources

## 5.2 Power-On Reset

A positive transition on the  $V_{DD}$  pin generates a power-on reset. The power-on reset is strictly for conditions during powering up and cannot be used to detect drops in power supply voltage.

A delay of 16 or 4064 internal bus cycles ( $t_{cyc}$ ) after the oscillator becomes active allows the clock generator to stabilize. If the  $\overline{RESET}$  pin is at logic 0 at the end of this multiple  $t_{cyc}$  time, the MCU remains in the reset condition until the signal on the  $\overline{RESET}$  pin goes to a logic 1.

## 5.3 External Reset

A logic 0 applied to the  $\overline{RESET}$  pin for a minimum of one and one half  $t_{cyc}$  generates an external reset. This pin is connected to a Schmitt trigger input gate to provide an upper and lower threshold voltage separated by a minimum amount of hysteresis. The external reset occurs whenever the  $\overline{RESET}$  pin is pulled below the lower threshold and remains in reset until the  $\overline{RESET}$  pin rises above the upper threshold. This active low input will generate the internal RST signal that resets the CPU and peripherals.

The  $\overline{RESET}$  pin can also be pulled to a low state by an internal pulldown device that is activated by three internal reset sources. This reset pulldown device will only be asserted for three to four cycles of the internal bus or as long as the internal reset source is asserted.

### NOTE

*Do not connect the  $\overline{RESET}$  pin directly to  $V_{DD}$ , as this may overload some power supply designs if the internal pulldown on the  $\overline{RESET}$  pin should activate. If an external reset function is not required, the  $\overline{RESET}$  pin should be left unconnected.*

## 5.4 Internal Resets

The four internally generated resets are:

- Initial power-on reset (POR) function
- COP watchdog timer reset
- Low-voltage reset (LVR)
- Illegal address detector

Only the COP watchdog timer reset, low-voltage reset, and illegal address detector will also assert the pulldown device on the  $\overline{RESET}$  pin for the duration of the reset function or for three to four internal bus cycles, whichever is longer.

### 5.4.1 Power-On Reset (POR)

The internal POR is generated on power-up to allow the clock oscillator to stabilize. The POR is strictly for power turn-on conditions and is not able to detect a drop in the power supply voltage (brown-out); that function can be performed by the LVR. Depending on the DELAY bit in the mask option register (MOR), there is an oscillator stabilization delay of 16 or 4064 internal bus cycles after the LPO becomes active.

The POR will generate the RST signal which will reset the CPU. If any other reset function is active at the end of the 16- or 4064-cycle delay, the RST signal will remain in the reset condition until the other reset condition(s) end.

POR will not activate the pulldown device on the  $\overline{RESET}$  pin.  $V_{DD}$  must drop below  $V_{POR}$  for the internal POR circuit to detect the next rise of  $V_{DD}$ .

### 5.4.2 Computer Operating Properly (COP) Reset

A timeout of the COP watchdog generates a COP reset. The COP watchdog is part of a software error detection system and must be cleared periodically to start a new timeout period. To clear the COP watchdog and prevent a COP reset, write a logic 0 to the COPC bit of the COPR register at location \$1FF0. The COPC bit, shown in Figure 5-2, is a write-only bit.

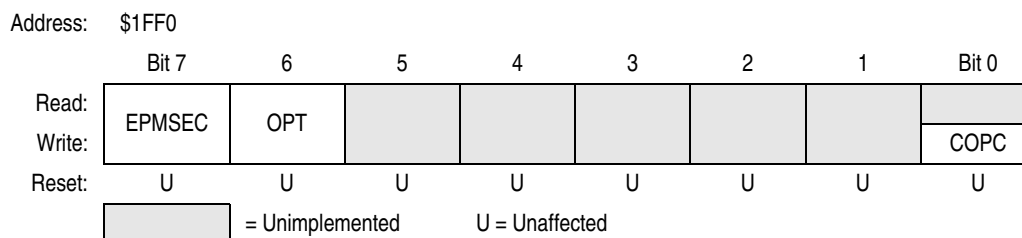

**Figure 5-2. COP and Security Register (COPR)**

#### EPMSEC — EPROM Security<sup>(1)</sup> Bit

The EPMSEC bit is an EPROM, write-only security bit to protect the contents of the user EPROM code stored in locations \$0700–\$1FFF.

#### OPT — Optional Features Bit

The OPT bit enables two additional features: direct drive by comparator 1 output to PB4 and voltage offset capability to sample capacitor in analog subsystem.

- 1 = Optional features enabled
- 0 = Optional features disabled

**NOTE**

See [8.7.1 Voltage Comparator 1](#) and [8.10 Sample and Hold](#) for further descriptions of the OPT bit.

#### COPC — COP Clear Bit

COPC is a write-only bit. Periodically writing a logic 0 to COPC prevents the COP watchdog from resetting the MCU. Reset clears the COPC bit.

- 1 = No effect on COP watchdog timer
- 0 = Reset COP watchdog timer

The COP watchdog reset will assert the pulldown device to pull the  $\overline{\text{RESET}}$  pin low for three to four cycles of the internal bus.

The COP watchdog reset function can be enabled or disabled by programming the COPEN bit in the MOR.

### 5.4.3 Low-Voltage Reset (LVR)

The LVR activates the RST reset signal to reset the device when the voltage on the  $V_{DD}$  pin falls below the LVR trip voltage. The LVR will assert the pulldown device to pull the  $\overline{\text{RESET}}$  pin low for three to four cycles of the internal bus.

1. No security feature is absolutely secure. However, Freescale’s strategy is to make reading or copying the EPROM/OTPROM difficult for unauthorized users.

## Resets

The LVR reset function can be enabled or disabled by programming the LVREN bit in the MOR.

### **NOTE**

*The LVR is intended for applications where the  $V_{DD}$  supply voltage normally operates above 4.5 volts.*

### 5.4.4 Illegal Address Reset

An opcode fetch (execution of an instruction) at an address that is not in the EPROM (locations \$0700–\$1FFF) or the RAM (locations \$0020–\$00FF) generates an illegal address reset. The illegal address reset will assert the pulldown device to pull the  $\overline{\text{RESET}}$  pin low for three to four cycles of the internal bus.

## 5.5 Reset States

This subsection describe how the various resets initialize the MCU.

### 5.5.1 CPU

A reset has these effects on the CPU:

- Loads the stack pointer with \$FF
- Sets the I bit in the condition code register, inhibiting interrupts
- Loads the program counter with the user-defined reset vector from locations \$1FFE and \$1FFF
- Clears the stop latch, enabling the CPU clock
- Clears the wait latch, bringing the CPU out of the wait mode

### 5.5.2 I/O Registers

A reset has these effects on input/output (I/O) registers:

- Clears bits in data direction registers configuring pins as inputs:
  - DDRA5–DDRA0 in DDRA for port A
  - DDRB7–DDRB0 in DDRB for port B
  - DDRC7–DDRC0 in DDRC for port C<sup>(1)</sup>
- Clears bits in pulldown inhibit registers to enable pulldown devices:
  - PDIA5–PDIA0 in PDRA for port A
  - PDIB7–PDIB0 in PDRB for port B
  - PDICH and PDICL in PDRA for port C<sup>(1)</sup>
- Has no effect on port A, B, or C<sup>(1)</sup> data registers
- Sets the IRQE bit in the interrupt status and control register (ISCR)

### 5.5.3 Core Timer

A reset has these effects on the core timer:

- Clears the core timer counter register (CTCR)
- Clears the core timer interrupt flag and enable bits in the core timer status and control register (CTSCR)
- Sets the real-time interrupt (RTI) rate selection bits (RT0 and RT1) such that the device will start with the longest real-time interrupt and longest COP timeout delays

1. Features related to port C are only available on the 28-pin MC68HC705JP7 devices

### 5.5.4 COP Watchdog

A reset clears the COP watchdog timeout counter.

### 5.5.5 16-Bit Programmable Timer

A reset has these effects on the 16-bit programmable timer:

- Initializes the timer counter registers (TMRH and TMRL) to a value of \$FFFC
- Initializes the alternate timer counter registers (ACRH and ACRL) to a value of \$FFFF
- Clears all the interrupt enables and the output level bit (OLVL) in the timer control register (TCR)
- Does not affect the input capture edge bit (IEDG) in the TCR
- Does not affect the interrupt flags in the timer status register (TSR)
- Does not affect the input capture registers (ICRH and ICRL)
- Does not affect the output compare registers (OCRH and OCRL)

### 5.5.6 Serial Interface

A reset has these effects on the serial interface:

- Clears all bits in the SIOP control register (SCR)
- Clears all bits in the SIOP status register (SSR)
- Does not affect the contents of the SIOP data register (SDR)

A reset, therefore, disables the SIOP and leaves the shared port B pins as general I/O. Any pending interrupt flag is cleared and the SIOP interrupt is disabled. Also the baud rate defaults to the slowest rate.

### 5.5.7 Analog Subsystem

A reset has these effects on the analog subsystem:

- Clears all the bits in the multiplex register (AMUX) bits except the hold switch bit (HOLD) which is set
- Clears all the bits in the analog control register (ACR)
- Clears all the bits in the analog status register (ASR)

A reset, therefore, connects the negative input of comparator 2 to the channel selection bus, which is switched to  $V_{SS}$ . Both comparators are set up as non-inverting (a higher positive voltage on the positive input results in a positive output) and both are powered down. The current source and discharge device on the PB0/AN0 pin is disabled and powered down. Any analog subsystem interrupt flags are cleared and the analog interrupt is disabled. Direct drive by comparator 1 to the PB4 pin and the voltage offset to the sample capacitor are disabled (if both are enabled by the OPT bit being set in the COPR).

### 5.5.8 External Oscillator and Internal Low-Power Oscillator

A reset presets the oscillator select bits (OM1 and OM2) in the interrupt status and control register (ISCR) such that the device runs from the internal oscillator (OM1 = 0, OM2 = 1) which has these effects on the oscillators:

- The internal low-power oscillator is enabled and selected.
- The external oscillator is disabled.
- The CPU bus clock is driven from the internal low-power oscillator.



# Chapter 6

## Operating Modes

### 6.1 Introduction

This section describes the operation of the device with respect to the oscillator source and the low-power modes:

- Stop mode
- Wait mode
- Halt mode
- Data-retention mode

### 6.2 Oscillator Source

The microcontroller unit (MCU) can be clocked by either an internal low-power oscillator (LPO) without external components or by an external pin oscillator (EPO) which uses external components. The enable and selection of the clock source is determined by the state of the oscillator select bits (OM1 and OM2) in the interrupt status and control register (ISCR) as shown in [Figure 6-1](#).

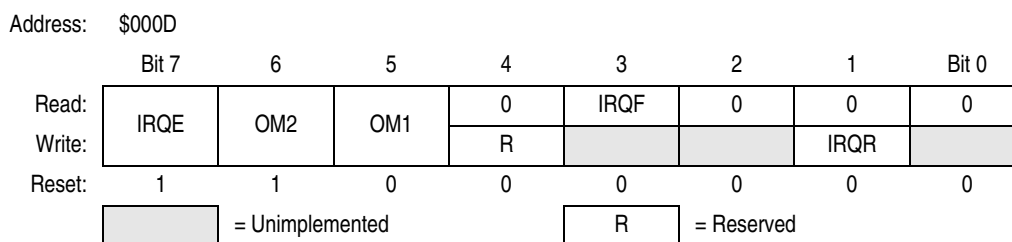

**Figure 6-1. IRQ Status and Control Register (ISCR)**

#### IRQE — External Interrupt Request Enable Bit

This read/write bit enables external interrupts. Refer to [Chapter 4 Interrupts](#) for more details.

#### OM1 and OM2 — Oscillator Select Bits

These bits control the selection and enabling of the oscillator source for the MCU. One choice is the internal LPO and the other oscillator is the EPO which is common to most M68HC05 MCU devices. The EPO uses external components like filter capacitors and a crystal or ceramic resonator and consumes more power than the LPO. The selection and enable conditions for these two oscillators are shown in [Table 6-1](#). Reset clears OM1 and sets OM2, which selects the LPO and disables the EPO. Therefore, the lowest power is consumed when OM1 is cleared. The state with both OM1 and OM2 set is provided so that the EPO can be started up and allowed to stabilize while the LPO still clocks the MCU.

**Table 6-1. Oscillator Selection**

OM2	OM1	Oscillator Selected	Internal Low-Power Oscillator (LPO)	External Pin Oscillator (EPO)	Power Consumption
0	0	Internal	Enabled	Disabled	Lowest
0	1	External	Disabled	Enabled	Normal
1	0	Internal	Enabled	Disabled	Lowest
1	1	Internal	Enabled	Enabled	Normal

**NOTE**

*When switching from LPO to EPO, the user must be careful to ensure that the EPO has been enabled and powered up long enough to stabilize before shifting clock sources.*

**IRQF — External Interrupt Request Flag**

The IRQF flag is a clearable, read-only bit that is set when an external interrupt request is pending. Refer to [Chapter 4 Interrupts](#) for more details.

**IRQR — Interrupt Request Reset Bit**

This write-only bit clears the IRQF flag bit and prevents redundant execution of interrupt routines. Refer to [Chapter 4 Interrupts](#) for more details.

## 6.3 Low-Power Modes

Four modes of operation reduce power consumption:

- Stop mode
- Wait mode
- Halt mode
- Data-retention mode

[Figure 6-2](#) shows the sequence of events in stop, wait, and halt modes.

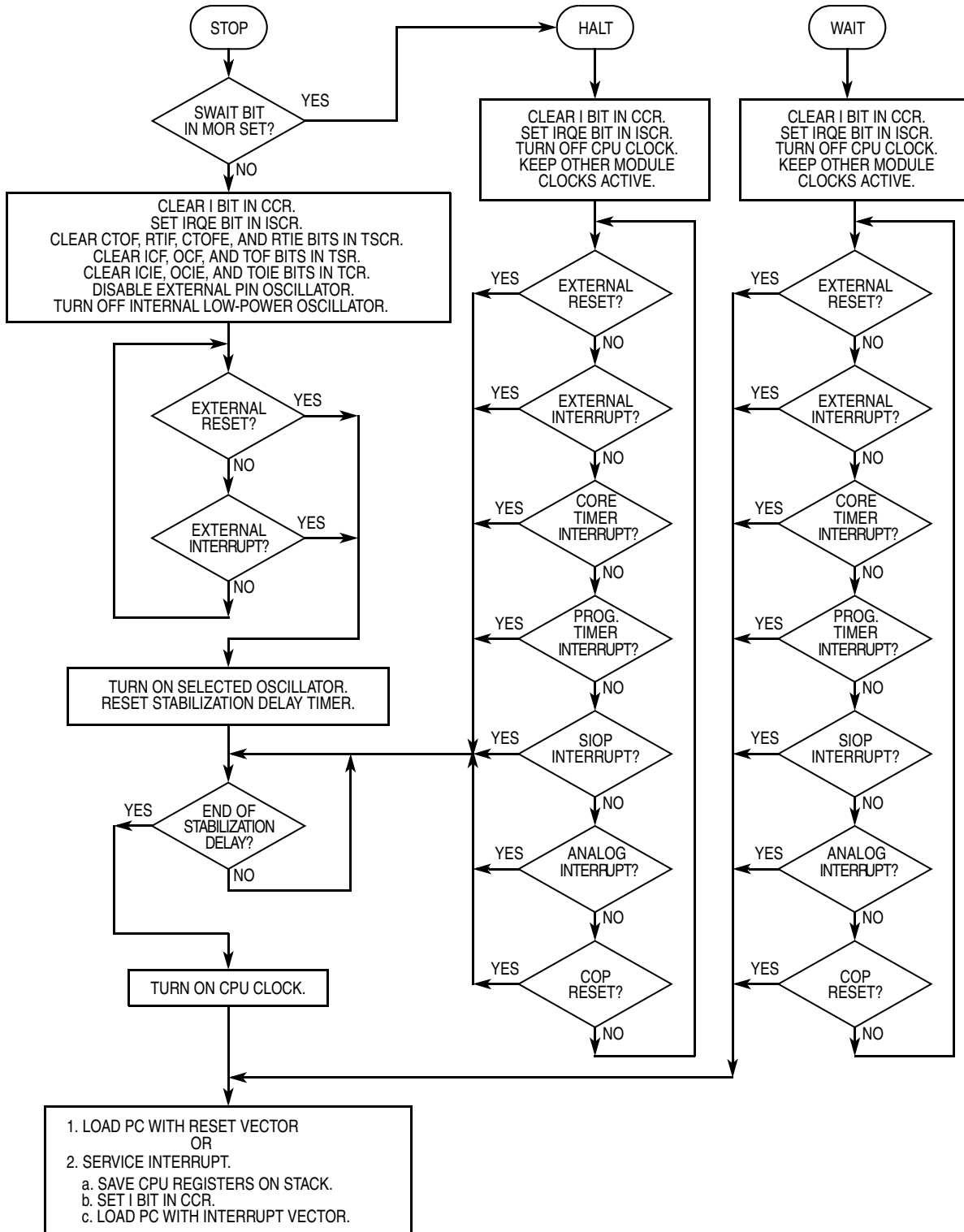

Figure 6-2. Stop/Wait/Halt Flowchart

### 6.3.1 Stop Mode

The STOP instruction puts the MCU in a mode with the lowest power consumption and affects the MCU as follows:

- Turns off the central processor unit (CPU) clock and all internal clocks by stopping both the external pin oscillator and the internal low-power oscillator. The selection of the oscillator by the OM1 and OM2 bits in the ISCR is not affected. The stopped clocks turn off the COP watchdog, the core timer, the programmable timer, the analog subsystem, and the SIOF.
- Removes any pending core timer interrupts by clearing the core timer interrupt flags (CTOF and RTIF) in the core timer status and control register (CTSCR)
- Disables any further core timer interrupts by clearing the core timer interrupt enable bits (CTOFE and RTIE) in the CTSCR
- Removes any pending programmable timer interrupts by clearing the timer interrupt flags (ICF, OCF, and TOF) in the timer status register (TSR)
- Disables any further programmable timer interrupts by clearing the timer interrupt enable bits (ICIE, OCIE, and TOIE) in the timer control register (TCR)
- Enables external interrupts via the  $\overline{\text{IRQ}}/\text{V}_{\text{PP}}$  pin by setting the IRQE bit in the IRQ status and control register (ISCR). External interrupts are also enabled via the PA0 through PA3 pins, if the port A interrupts are enabled by the PIRQ bit in the mask option register (MOR).
- Enables interrupts in general by clearing the I bit in the condition code register

The STOP instruction does not affect any other bits, registers, or I/O lines.

The following conditions bring the MCU out of stop mode:

- An external interrupt signal on the  $\overline{\text{IRQ}}/\text{V}_{\text{PP}}$  pin — A high-to-low transition on the  $\overline{\text{IRQ}}/\text{V}_{\text{PP}}$  pin loads the program counter with the contents of locations \$1FFA and \$1FFB.
- An external interrupt signal on a port A external interrupt pin — If selected by the PIRQ bit in the MOR, a low-to-high transition on a PA3–PA0 pin loads the program counter with the contents of locations \$1FFA and \$1FFB.
- External reset — A logic 0 on the  $\overline{\text{RESET}}$  pin resets the MCU and loads the program counter with the contents of locations \$1FFE and \$1FFF.

When the MCU exits stop mode, processing resumes after a stabilization delay of 16 or 4064 internal bus cycles, depending on the state of the DELAY bit in the MOR.

**NOTE**

*Execution of the STOP instruction without setting the SWAIT bit in the MOR will cause the oscillators to stop, and, therefore, disable the COP watchdog timer. If the COP watchdog timer is to be used, stop mode should be changed to halt mode as described in [6.3.3 Halt Mode](#).*

### 6.3.2 Wait Mode

The WAIT instruction puts the MCU in a low-power wait mode which consumes more power than the stop mode and affects the MCU as follows:

- Enables interrupts by clearing the I bit in the condition code register
- Enables external interrupts by setting the IRQE bit in the IRQ status and control register
- Stops the CPU clock which drives the address and data buses, but allows the selected oscillator to continue to clock the core timer, programmable timer, analog subsystem, and SIOPI

The WAIT instruction does not affect any other bits, registers, or I/O lines.

These conditions restart the CPU bus clock and bring the MCU out of wait mode:

- An external interrupt signal on the  $\overline{\text{IRQ}}/V_{\text{PP}}$  pin — A high-to-low transition on the  $\overline{\text{IRQ}}/V_{\text{PP}}$  pin loads the program counter with the contents of locations \$1FFA and \$1FFB.
- An external interrupt signal on a port A external interrupt pin — If selected by PIRQ bit in the MOR, a low-to-high transition on a PA3–PA0 pin loads the program counter with the contents of locations \$1FFA and \$1FFB.
- A core timer interrupt — A core timer overflow or a real-time interrupt loads the program counter with the contents of locations \$1FF8 and \$1FF9.
- A programmable timer interrupt — A programmable timer interrupt driven by an input capture, output compare, or timer overflow loads the program counter with the contents of locations \$1FF6 and \$1FF7.
- An SIOPI interrupt — An SIOPI interrupt driven by the completion of transmitted or received 8-bit data loads the program counter with the contents of locations \$1FF4 and \$1FF5.
- An analog subsystem interrupt — An analog subsystem interrupt driven by a voltage comparison loads the program counter with the contents of locations \$1FF2 and \$1FF3.
- A COP watchdog reset — A timeout of the COP watchdog resets the MCU and loads the program counter with the contents of locations \$1FFE and \$1FFF. Software can enable real-time interrupts so that the MCU can periodically exit the wait mode to reset the COP watchdog.
- An external reset — A logic 0 on the  $\overline{\text{RESET}}$  pin resets the MCU and loads the program counter with the contents of locations \$1FFE and \$1FFF.

When the MCU exits the wait mode, there is no delay before code executes like occurs when exiting the stop or halt modes.

### 6.3.3 Halt Mode

The STOP instruction puts the MCU in halt mode if selected by the SWAIT bit in the MOR. Halt mode is identical to wait mode, except that a variable recovery delay occurs when the MCU exits halt mode. A recovery time of from 1 to 16 or from 1 to 4064 internal bus cycles can be selected by the DELAY bit in the MOR.

If the SWAIT bit is set in the MOR to put the MCU in halt mode, the COP watchdog cannot be turned off inadvertently by a STOP instruction.

### 6.3.4 Data-Retention Mode

In the data-retention mode, the MCU retains random-access memory (RAM) contents and CPU register contents at  $V_{DD}$  voltages as low as 2.0 Vdc. The data retention feature allows the MCU to remain in a low-power consumption state during which it retains data, but the CPU cannot execute instructions. Current consumption in this mode is not tested.

To put the MCU in the data retention mode:

1. Drive the  $\overline{\text{RESET}}$  pin to a logic 0.
2. Lower the  $V_{DD}$  voltage. The  $\overline{\text{RESET}}$  pin must remain low continuously during data retention mode.

To take the MCU out of the data retention mode:

1. Return  $V_{DD}$  to normal operating voltage.
2. Return the  $\overline{\text{RESET}}$  pin to a logic 1.

# Chapter 7

## Parallel Input/Output

### 7.1 Introduction

The MC68HC705JJ7 has 14 bidirectional input/output (I/O) pins which form two parallel I/O ports, A and B. The MC68HC705JP7 has 22 bidirectional I/O pins which form three parallel I/O ports, A, B and C. Each I/O pin is programmable as an input or an output. The contents of the data direction registers determine the data direction of each of the I/O pins. All I/O pins have software programmable pulldown devices which can be enabled or disabled globally by the SWPDI bit in the mask option register (MOR).

### 7.2 Port A

Port A is a 6-bit, general-purpose, bidirectional I/O port with these features:

- Individual programmable pulldown devices
- High current sinking capability on all port A pins, with a maximum total for port A
- High current sourcing capability on all port A pins, with a maximum total for port A
- External interrupt capability (pins PA3–PA0)

#### 7.2.1 Port A Data Register

The port A data register (PORTA) contains a bit for each of the port A pins. When a port A pin is programmed to be an output, the state of its data register bit determines the state of the output pin. When a port A pin is programmed to be an input, reading the port A data register returns the logic state of the pin. The upper two bits of the port A data register will always read as logic 0s.

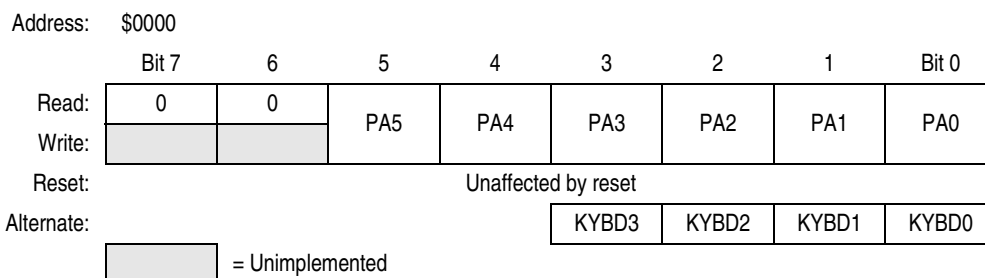

**Figure 7-1. Port A Data Register (PORTA)**

#### PA5–PA0 — Port A Data Bits

These read/write bits are software programmable. Data direction of each bit is under the control of the corresponding bit in the port A data direction register (DDRA). Reset has no effect on port A data.

## 7.2.2 Data Direction Register A

The contents of the port A data direction register (DDRA) determine whether each port A pin is an input or an output. Writing a logic 1 to a DDRA bit enables the output buffer for the associated port A pin. A DDRA bit set to a logic 1 also disables the pull-down device for that pin. Writing a logic 0 to a DDRA bit disables the output buffer for the associated port A pin. The upper two bits always read as logic 0s. A reset initializes all DDRA bits to logic 0s, configuring all port A pins as inputs and disabling the voltage comparators from driving PA4 or PA5.

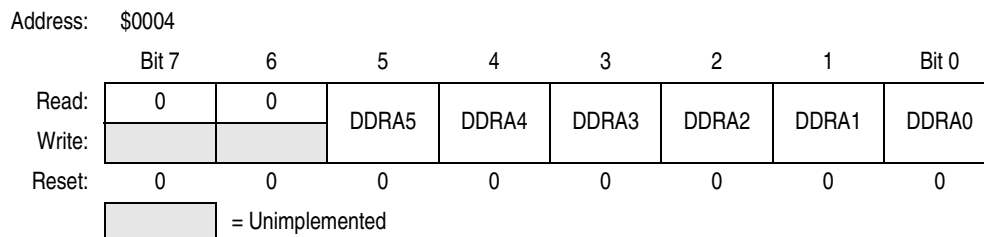

**Figure 7-2. Data Direction Register A (DDRA)**

### DDRA5–DDRA0 — Port A Data Direction Bits

These read/write bits control port A data direction. Reset clears the DDRA5–DDRA0 bits.

- 1 = Corresponding port A pin configured as output and pull-down device disabled
- 0 = Corresponding port A pin configured as input

## 7.2.3 Pulldown Register A

All port A pins can have software programmable pull-down devices enabled or disabled globally by SWPDI bit in the MOR. These pull-down devices are controlled by the write-only pulldown register A (PDRA) shown in [Figure 7-3](#). Clearing the PDIA5–PDIA0 bits in the PDRA turns on the pull-down devices if the port A pin is an input. Reading the PDRA returns undefined results since it is a write-only register; therefore, do not change the value in PDRA with read/modify/write instructions. On the MC68HC705JP7 the PDRA contains two pulldown control bits (PDICH and PDICL) for port C. Reset clears the PDIA5–PDIA0, PDICH, and PDICL bits, which turns on all the port A and port C pull-down devices.

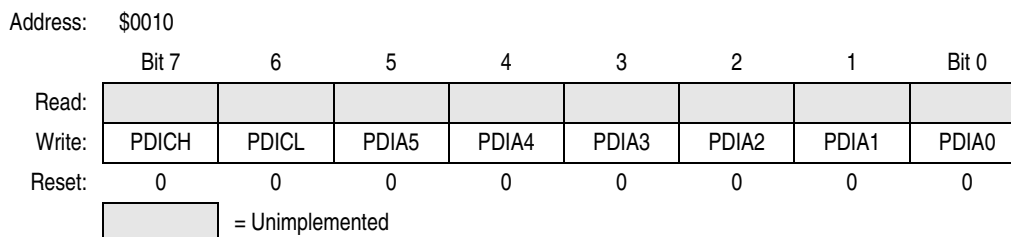

**Figure 7-3. Pulldown Register A (PDRA)**

### PDICH — Upper Port C Pulldown Inhibit Bits (MC68HC705JP7)

Writing to this write-only bit controls the port C pull-down devices on the upper four bits (PC4–PC7). Reading these pulldown register A bits returns undefined data. Reset clears bit PDICH.

- 1 = Upper four port C pins pull-down devices turned off
- 0 = Upper four port C pins pull-down devices turned on if pin has been programmed by the DDRC to be an input

**PDICL — Lower Port C Pulldown Inhibit Bits (MC68HC705JP7)**

Writing to this write-only bit controls the port C pulldown devices on the lower four bits (PC0–PC3). Reading these pulldown register A bits returns undefined data. Reset clears bit PDICL.

- 1 = Lower four port C pins pulldown devices turned off
- 0 = Lower four port C pins pulldown devices turned on if pin has been programmed by the DDRC to be an input

**PDIA5–PDIA0 — Port A Pulldown Inhibit Bits**

Writing to these write-only bits controls the port A pulldown devices. Reading these pulldown register A bits returns undefined data. Reset clears bits PDIA5–PDIA0.

- 1 = Corresponding port A pin pulldown device turned off
- 0 = Corresponding port A pin pulldown device turned on if pin has been programmed by the DDRA to be an input

**7.2.4 Port A External Interrupts**

The PIRQ bit in the MOR enables the PA3–PA0 pins to serve as external interrupt pins in addition to the  $\overline{IRQ}/V_{PP}$  pin. The active interrupt state for the PA3–PA0 pins is a logic 1 or a rising edge. A state of the PIRQ bit in the MOR determines whether external interrupt inputs are edge-sensitive only or both edge- and level-sensitive. Port A interrupts are also interactive with each other and the  $\overline{IRQ}/V_{PP}$  pin as described in 4.5 External Interrupts.

**NOTE**

*When testing for external interrupts, the BIH and BIL instructions test the voltage on the  $\overline{IRQ}/V_{PP}$  pin, not the state of the internal IRQ signal. Therefore, BIH and BIL cannot test the port A external interrupt pins.*

**7.2.5 Port A Logic**

When a PA0:PA5 pin is programmed as an output, reading the port bit actually reads the value of the data latch and not the voltage on the pin itself. When a PA0:PA5 pin is programmed as an input, reading the port bit reads the voltage level on the pin. The data latch can always be written, regardless of the state of its DDR bit. Figure 7-4 shows the I/O logic of PA0–PA5 pins of port A.

The data latch can always be written, regardless of the state of its DDR bits. Table 7-1 summarizes the operations of the port A pins.

**Table 7-1. Port A Pin Functions**

Port A Pin(s)	SWPDI (in MOR)	Port A		PORTA Access (Pin or Data Register)		Result on Port A Pins	
		PDIAx	DDRAx <sup>(1)</sup>	Read	Write	Pulldown	Pin
PA0	0	0	0	Pin	Data	On	PAx in
PA1	0	1	0	Pin	Data	Off	PAx in
PA2							
PA3	1	X	0	Pin	Data	Off	PAx in
PA4	X <sup>(2)</sup>	X <sup>(2)</sup>	1	Data	Data	Off	PAx out
PA5							

1. DDRA can always be read or written.  
 2. Don't care

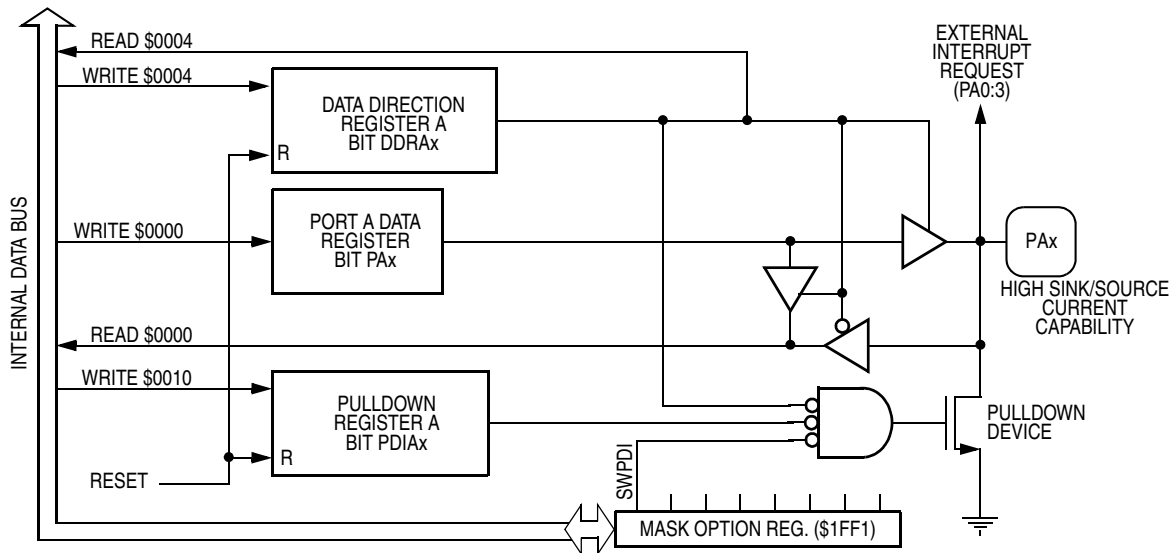

Figure 7-4. Port A I/O Circuit

### 7.3 Port B

Port B is an 8-bit, general-purpose, bidirectional I/O port with these features:

- Programmable pulldown devices
- PB0–PB4 are shared with the analog subsystem.
- PB3 and PB4 are shared with the 16-bit programmable timer.
- PB4 can be driven directly by the output of comparator 1.
- PB5–PB7 are shared with the simple serial interface (SIOP).
- High current sinking capability on the PB4 pin
- High current sourcing capability on the PB4 pin

#### 7.3.1 Port B Data Register

The port B data register (PORTB) contains a bit for each of the port B pins. When a port B pin is programmed to be an output, the state of its data register bit determines the state of the output pin. When a port B pin is programmed to be an input, reading the port B data register returns the logic state of the pin. Reset has no effect on port B data.

Address:	\$0001							
	Bit 7	6	5	4	3	2	1	Bit 0
Read:	PB7	PB6	PB5	PB4	PB3	PB2	PB1	PB0
Write:	PB7	PB6	PB5	PB4	PB3	PB2	PB1	PB0
Reset:	Unaffected by reset							
Alternate:	SCK	SDI	SDO	AN4	AN3	AN2	AN1	AN0
Alternate:	SCK	SDI	SDO	TCMP	TCAP	AN2	AN1	AN0
Alternate:	SCK	SDI	SDO	CMP1	TCAP	AN2	AN1	AN0

Figure 7-5. Port B Data Register (PORTB)

### PB0-PB7 — Port B Data Bits

These read/write bits are software programmable. Data direction of each bit is under the control of the corresponding bit in data direction register B. Reset has no effect on port B data.

### 7.3.2 Data Direction Register B

The contents of the port B data direction register (DDRB) determine whether each port B pin is an input or an output. Writing a logic 1 to a DDRB bit enables the output buffer for the associated port B pin. A DDRB bit set to a logic 1 also disables the pull-down device for that pin. Writing a logic 0 to a DDRB bit disables the output buffer for the associated port B pin. A reset initializes all DDRB bits to logic 0s, configuring all port B pins as inputs.

Address: \$0005

	Bit 7	6	5	4	3	2	1	Bit 0
Read:	DDRB7	DDRB6	DDRB5	DDRB4	DDRB3	DDRB2	DDRB1	DDRB0
Write:	DDRB7	DDRB6	DDRB5	DDRB4	DDRB3	DDRB2	DDRB1	DDRB0
Reset:	0	0	0	0	0	0	0	0

**Figure 7-6. Data Direction Register B (DDRB)**

### DDRB7–DDRB0 — Port B Data Direction Bits

These read/write bits control port B data direction. Reset clears the bits DDRB7–DDRB0.

- 1 = Corresponding port B pin configured as output and pull-down device disabled
- 0 = Corresponding port B pin configured as input

### 7.3.3 Pull-down Register B

All port B pins can have software programmable pull-down devices enabled or disabled globally by the SWPDI bit in the MOR. These pull-down devices are individually controlled by the write-only pull-down register B (PDRB) shown in Figure 7-7. Clearing the PDIB7–PDIB0 bits in the PDRB turns on the pull-down devices if the port B pin is an input. Reading the PDRB returns undefined results since it is a write-only register. Reset clears the PDIB7–PDIB0 bits, which turns on all the port B pull-down devices.

Address: \$0011

	Bit 7	6	5	4	3	2	1	Bit 0
Read:								
Write:	PDIB7	PDIB6	PDIB5	PDIB4	PDIB3	PDIB2	PDIB1	DIB0
Reset:	0	0	0	0	0	0	0	0

= Unimplemented

**Figure 7-7. Pull-down Register B (PDRB)**

### PDIB7–PDIB0 — Port B Pull-down Inhibit Bits

Writing to these write-only bits controls the port B pull-down devices. Reading these pull-down register B bits returns undefined data. Reset clears bits PDIB7–PDIB0.

- 1 = Corresponding port B pin pull-down device turned off
- 0 = Corresponding port B pin pull-down device turned on if pin has been programmed by the DDRB to be an input

### 7.3.4 Port B Logic

All port B pins have the general I/O port logic similar to port A; but they also share this function with inputs or outputs from other modules, which are also attached to the pin itself or override the general I/O function. PB0, PB1, PB2, and PB3 simply share their inputs with another module. PB4, PB5, PB6, and PB7 will have their operation altered by outputs or controls from other modules.

### 7.3.5 PB0, PB1, PB2, and PB3 Logic

The typical I/O logic shown in [Figure 7-8](#) is used for PB0, PB1, PB2, and PB3 pins of port B. When these port B pins are programmed as an output, reading the port bit actually reads the value of the data latch and not the voltage on the pin itself. When these port B pins are programmed as an input, reading the port bit reads the voltage level on the pin. The data latch can always be written, regardless of the state of its DDRB bit. The operations of the PB0–PB3 pins are summarized in [Table 7-2](#).

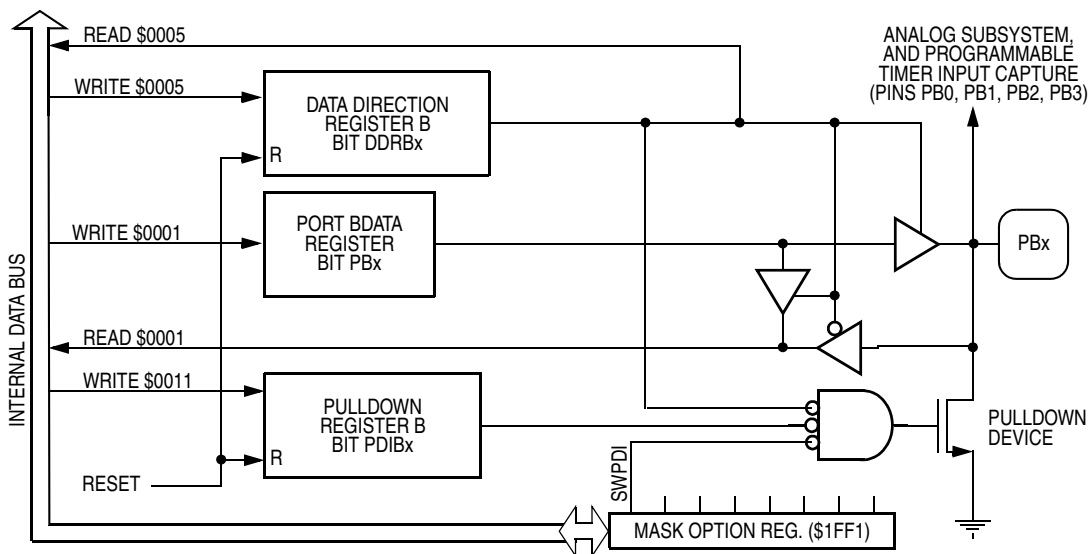

**Figure 7-8. PB0–PB3 Pin I/O Circuit**

The PB0–PB3 pins share their inputs with another module. When using the other attached module, these conditions must be observed:

1. If the DDRB configures the pin as an output, then the port data register can provide an output which may conflict with any external input source to the other module. The pull-down device will be disabled in this case.
2. If the DDRB configures the pin as an input, then reading the port data register will return the state of the input in terms of the digital threshold for that pin (analog inputs will default to logic states).
3. If DDRB configures the pin as an input and the pull-down device is activated for a pin, it will also load the input to the other module.
4. If interaction between the port logic and the other module is not desired, the pin should be configured as an input by clearing the appropriate DDRB bit. The input pull-down device is disabled by clearing the appropriate PDRB bit (or by disabling programmable pulldowns with the SWPDI bit in the MOR).

### 7.3.6 PB4/AN4/TCMP/CMP1 Logic

The PB4/AN4/TCMP/CMP1 pin can be used as a simple I/O port pin, be controlled by the OLVL bit from the output compare function of the 16-bit programmable timer, or be controlled directly by the output of comparator 1 as shown in Figure 7-9. The PB4 data, the programmable timer OLVL bit, and the output of comparator 1 are all logically ORed together to drive the pin. Also, the analog subsystem input channel 4 multiplexer is connected directly to this pin. The operations of PB4 pin are summarized in Table 7-2.

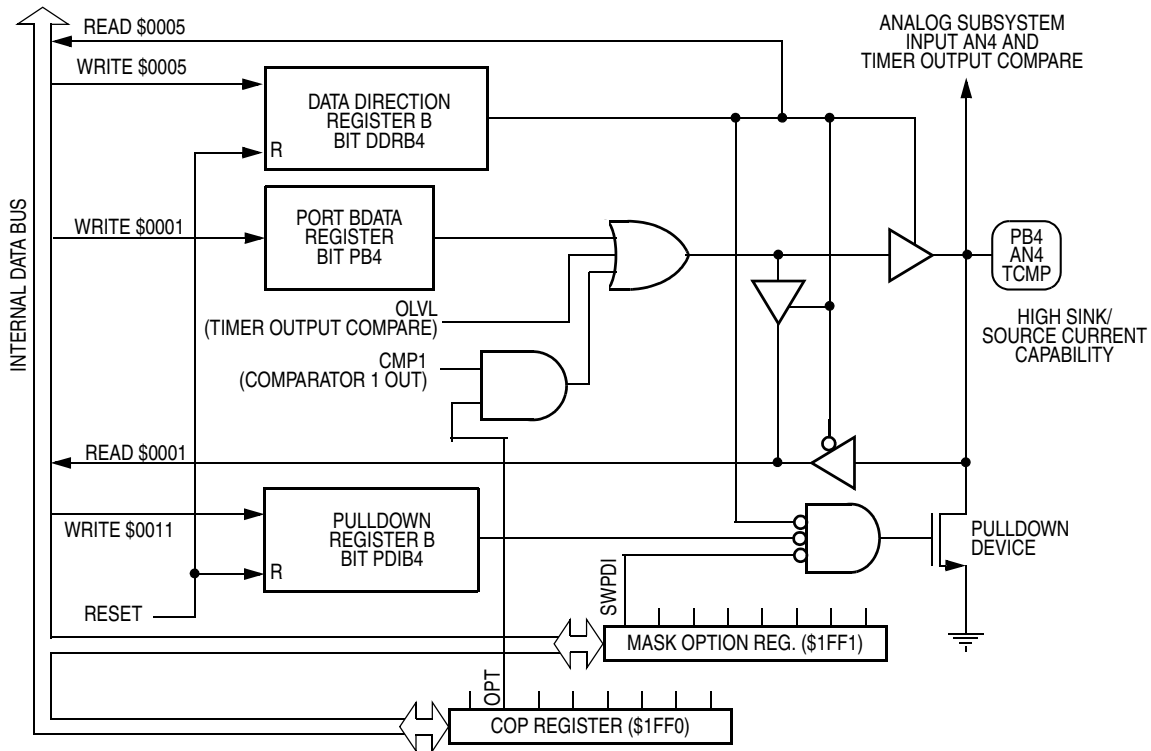

**Figure 7-9. PB4/AN4/TCMP/CMP1 Pin I/O Circuit**

When using the PB4/AN4/TCMP/CMP1 pin, these interactions must be noted:

1. If the OLVL timer output compare function is the required output function, then the DDRB4 bit must be set, the PB4 data bit must be cleared, and the OPT bit in the COPR must be cleared. The PB4/AN4/TCMP/CMP1 pin becomes an output which follows the state of the OLVL bit. The pull-down device will be disabled in this case. The analog subsystem would not normally use this pin as an analog input in this case.
2. If the PB4 data bit is the required output function, then the DDRB4 bit must be set, the OLVL bit in the TCR must be cleared, and the OPT bit in the COPR must be cleared. The pull-down device will be disabled in this case. The analog subsystem would not normally use this pin as an analog input in this case.
3. If the comparator 1 output is the desired output function, then the PB4 data bit must be cleared, the DDRB4 bit must be set, the OLVL bit in the TCR must be cleared, and the OPT bit in the COPR must be set. The PB4/AN4/TCMP/CMP1 pin becomes an output which follows the state of the OLVL bit. The pull-down device will be disabled in this case. The analog subsystem would not normally use this pin as an analog input in this case.

## Parallel Input/Output

- If the PB4 pin is to be an input to the analog subsystem or a digital input, then the DDRB4 bit must be cleared. In this case, the PB4 pin can still be read, but the voltage present will be returned as a binary value. Depending on the external application, the PB4 pulldown may also be disabled by setting the PDIB4 pulldown inhibit bit. In this case, both the digital and analog functions connected to this pin can be utilized.

**Table 7-2. Port B Pin Functions — PB0–PB4**

Port B Pin	Control Bits							PORTB Access (Pin or Data Register)		Result on Port B Pins	
	Comparator 1			Timer	SWPDI in MOR	Port B		Read	Write	Pulldown	Pin
	CMP1	COE1	OPT in COPR	OLVL		PDIBx	DDRBx <sup>(1)</sup>				
PB0 PB1 PB2 PB3	X <sup>(2)</sup>	X <sup>(2)</sup>	X <sup>(2)</sup>	X <sup>(2)</sup>	0	0	0	Pin	Data	On	PBx in
					0	1	0	Pin	Data	Off	PBx in
					1	X <sup>(2)</sup>	0	Pin	Data	Off	PBx in
					X <sup>(2)</sup>	X <sup>(2)</sup>	1	Data	Data	Off	PBx out
PB4	X <sup>(2)</sup>	X <sup>(2)</sup>	X <sup>(2)</sup>	X <sup>(2)</sup>	0	0	0	Pin	Data	On	PB4 in
					0	1	0	Pin	Data	Off	PB4 in
					1	X <sup>(2)</sup>	0	Pin	Data	Off	PB4 in
	X <sup>(2)</sup>	X <sup>(2)</sup>	0	0	X <sup>(2)</sup>	X <sup>(2)</sup>	1	Data	Data	Off	PB4 out
	X <sup>(2)</sup>	0	1	0	X <sup>(2)</sup>	X <sup>(2)</sup>	1	Data	Data	Off	PB4 out
	0	1	1	0	X <sup>(2)</sup>	X <sup>(2)</sup>	1	Data	Data	Off	PB4 out
	X <sup>(2)</sup>	X <sup>(2)</sup>	X <sup>(2)</sup>	1	X <sup>(2)</sup>	X <sup>(2)</sup>	1	1	Data	Off	1
1	1	1	X <sup>(2)</sup>	X <sup>(2)</sup>	X <sup>(2)</sup>	1	1	Data	Off	1	

- DDRB can always be read or written.
- Don't care

### 7.3.7 PB5/SDO Logic

The PB5/SDO pin can be used as a simple I/O port pin or be controlled by the SIOP serial interface as shown in Figure 7-10. The operations of the PB5 pin are summarized in Table 7-3.

When using the PB5/SDO pin, these interactions must be noted:

1. If the SIOP function is required, then the SPE bit in the SCR must be set. This causes the PB5/SDO pin buffer to be enabled and to be driven by the serial data output (SDO) from the SIOP. The pull-down device will be disabled in this case.
2. If the SIOP function is in control of the PB5/SDO pin, the DDRB5 and PB5 data register bits are still accessible to the CPU and can be altered or read without affecting the SIOP functionality. However, if the DDRB5 bit is cleared, reading the PB5 data register will return the current state of the PB5/SDO pin.

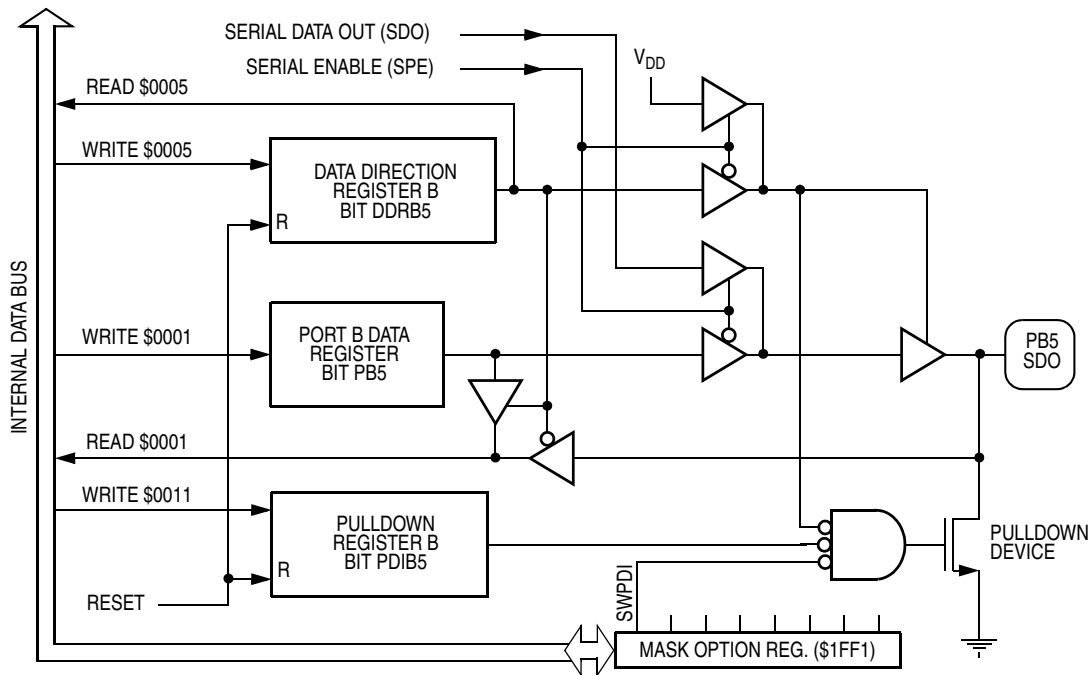
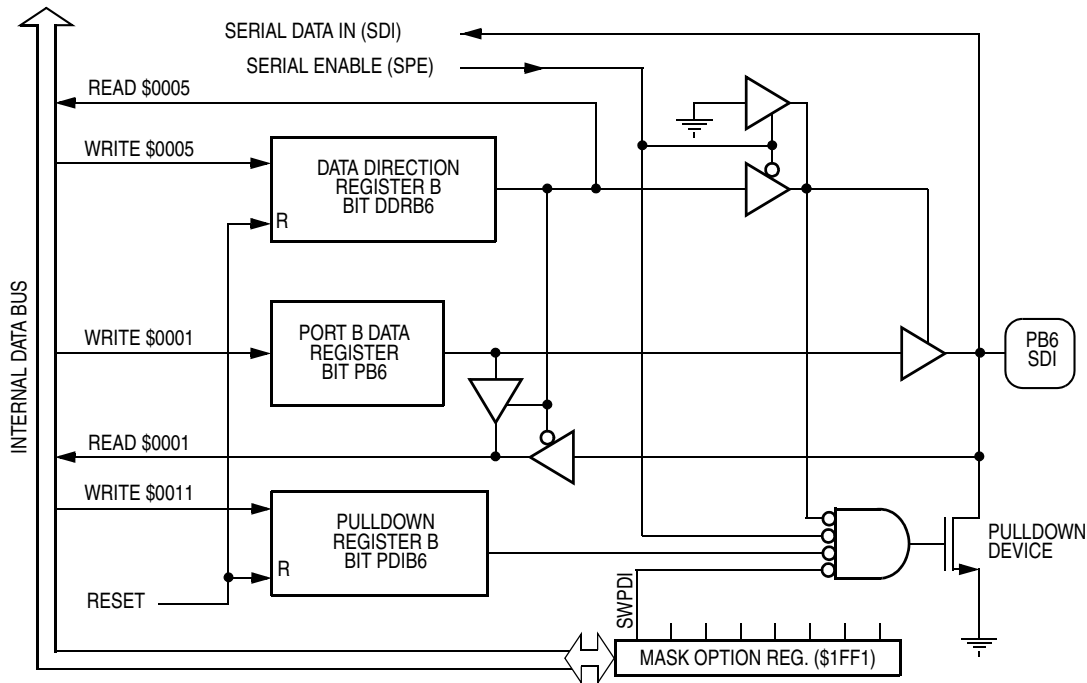

Figure 7-10. PB5/SDO Pin I/O Circuit

3. If the SIOP function is terminated by clearing the SPE bit in the SCR, then the last conditions stored in the DDRB5, PDIB5, and PB5 register bits will then control the PB5/SDO pin.
4. If the PB5/SDO pin is to be a digital input, then both the SPE bit in the SCR and the DDRB5 bit must be cleared. Depending on the external application, the pull-down device may also be disabled by setting the PDIB5 pull-down inhibit bit.
5. If the PB5/SDO pin is to be a digital output, then the SPE bit in the SCR must be cleared and the PDIB5 bit must be set. The pull-down device will be disabled in this case.

### 7.3.8 PB6/SDI Logic

The PB6/SDI pin can be used as a simple I/O port pin or be controlled by the SIOP serial interface as shown in Figure 7-11. The operations of PB6/SDI pin are summarized in Table 7-3.



**Figure 7-11. PB6/SDI Pin I/O Circuit**

When using the PB6/SDI pin, these interactions must be noted:

1. If the SIOP function is required, then the SPE bit in the SCR must be set. This causes the PB6/SDI pin buffer to be disabled to allow the PB6/SDI pin to act as an input that feeds the serial data input (SDI) of the SIOP. The pull-down device is disabled in this case.
2. If the SIOP function is in control of the PB6/SDI pin, the DDRB6 and PB6 data register bits are still accessible to the CPU and can be altered or read without affecting the SIOP functionality. However, if the DDRB6 bit is cleared, reading the PB6 data register will return the current state of the PB6/SDI pin.
3. If the SIOP function is terminated by clearing the SPE bit in the SCR, then the last conditions stored in the DDRB6, PDIB6, and PB6 register bits will then control the PB6/SDI pin.
4. If the PB6/SDI pin is to be a digital input, then both the SPE bit in the SCR and the DDRB6 bit must be cleared. Depending on the external application, the pull-down device may also be disabled by setting the PDIB6 pull-down inhibit bit.
5. If the PB6/SDI pin is to be a digital output, then the SPE bit in the SCR must be cleared and the DDRB6 bit must be set. The pull-down device will be disabled in this case.

### 7.3.9 PB7/SCK Logic

The PB7/SCK pin can be used as a simple I/O port pin or be controlled by the SIOP serial interface as shown in Figure 7-12. The operations of the PB7/SCK pin are summarized in Table 7-3.

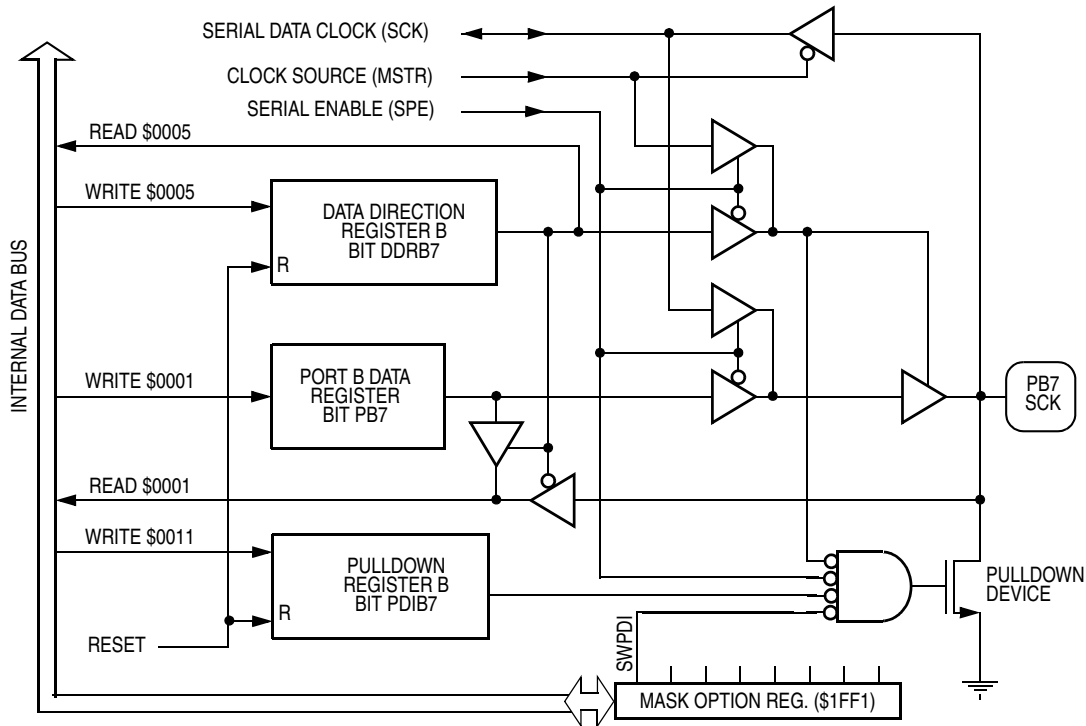

**Figure 7-12. PB7/SCK Pin I/O Circuit**

When using the PB7/SCK pin, these interactions must be noted:

1. If the SIOP function is required, then the SPE bit in the SCR must be set. This causes the PB7/SCK pin buffer to be controlled by the MSTR control bit in the SCR. The pull-down device is disabled in these cases.
  - a. If the MSTR bit is set, then the PB7/SCK pin buffer will be enabled and driven by the serial data clock (SCK) from the SIOP.
  - b. If the MSTR bit is clear, then the PB7/SCK pin buffer will be disabled, allowing the PB7/SCK pin to drive the serial data clock (SCK) into the SIOP.
2. If the SIOP function is in control of the PB7/SCK pin, the DDRB7 and PB7 data register bits are still accessible to the CPU and can be altered or read without affecting the SIOP functionality. However, if the DDRB7 bit is cleared, reading the PB7 data register will return the current state of the PB7/SCK pin.
3. If the SIOP function is terminated by clearing the SPE bit in the SCR, then the last conditions stored in the DDRB7, PDIB7, and PB7 register bits will then control the PB7/SCK pin.
4. If the PB7/SCK pin is to be a digital input, then both the SPE bit in the SCR and the DDRB7 bit must be cleared. Depending on the external application, the pull-down device may also be disabled by setting the PDIB7 pull-down inhibit bit.

- If the PB7/SCK pin is to be a digital output, then the SPE bit in the SCR must be cleared and the DDRB7 bit must be set. The pulldown device will be disabled when the pin is set as an output.

**Table 7-3. Port B Pin Functions — PB5–PB7**

Port B Pin	Control Bits				PORTB Access (Pin or Data Register)		Result on Port B Pins		
	SIOP		SWPDI in MOR	Port B		Read	Write	Pulldown	Pin
	SPE	MSTR		PDIBx	DDRBx <sup>(1)</sup>				
PB5	0	X <sup>(2)</sup>	0	0	0	Pin	Data	On	PB5 in
			0	1	0	Pin	Data	Off	PB5 in
			1	X	0	Pin	Data	Off	PB5 in
			X <sup>(2)</sup>	X <sup>(2)</sup>	1	Data	Data	Off	PB5 out
	1	X <sup>(2)</sup>	X <sup>(2)</sup>	X <sup>(2)</sup>	0	SDO	Data	Off	SDO out
					1	Data	Data	Off	SDO out
PB6	0	X <sup>(2)</sup>	0	0	0	Pin	Data	On	PB6 in
			0	1	0	Pin	Data	Off	PB6 in
			1	X <sup>(2)</sup>	0	Pin	Data	Off	PB6 in
			X <sup>(2)</sup>	X <sup>(2)</sup>	1	Data	Data	Off	PB6 out
	1	X <sup>(2)</sup>	X <sup>(2)</sup>	X <sup>(2)</sup>	0	SDI	Data	Off	SDI in
					1	Data	Data	Off	SDI in
PB7	0	X <sup>(2)</sup>	0	0	0	Pin	Data	On	PB7 in
			0	1	0	Pin	Data	Off	PB7 in
			1	X <sup>(2)</sup>	0	Pin	Data	Off	PB7 in
			X <sup>(2)</sup>	X <sup>(2)</sup>	1	Data	Data	Off	PB7 out
	1	0	X <sup>(2)</sup>	X <sup>(2)</sup>	0	SCK	Data	Off	SCK in
					1	Data	Data	Off	SCK in
		1	X <sup>(2)</sup>	X <sup>(2)</sup>	0	SCK	Data	Off	SCK out
					1	Data	Data	Off	SCK out

1. DDRB can always be read or written.  
 2. Don't care

## 7.4 Port C (28-Pin Versions Only)

Port C is an 8-bit, general-purpose, bidirectional I/O port with these features:

- Individual programmable pulldown devices
- High current sinking capability on all port C pins, with a maximum total for port C
- High current sourcing capability on all port C pins, with a maximum total for port C

### 7.4.1 Port C Data Register

The port C data register (PORTC) contains a bit for each of the port C pins. When a port C pin is programmed to be an output, the state of its data register bit determines the state of the output pin. When a port C pin is programmed to be an input, reading the port C data register returns the logic state of the pin.



**Figure 7-13. Port C Data Register (PORTC)**

#### PC7–PC0 — Port C Data Bits

These read/write bits are software programmable. Data direction of each bit is under the control of the corresponding bit in the port C data direction register (DDRC). Reset has no effect on port C data.

### 7.4.2 Data Direction Register C

The contents of the port C data direction register (DDRC) determine whether each port C pin is an input or an output. Writing a logic 1 to a DDRC bit enables the output buffer for the associated port C pin. A DDRC bit set to a logic 1 also disables the pulldown device for that pin. Writing a logic 0 to a DDRC bit disables the output buffer for the associated port C pin. A reset initializes all DDRC bits to logic 0s, configuring all port C pins as inputs.

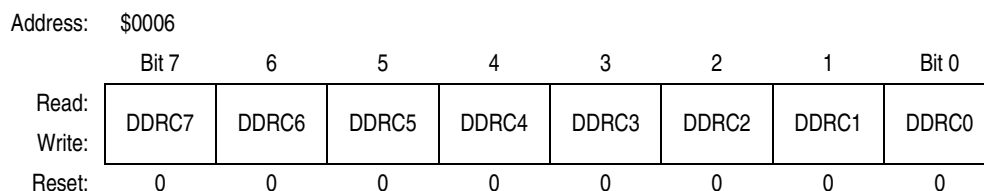

**Figure 7-14. Data Direction Register C (DDRC)**

#### DDRC7–DDRC0 — Port C Data Direction Bits

These read/write bits control port C data direction. Reset clears the DDRC7–DDRC0 bits.

- 1 = Corresponding port C pin configured as output and pulldown device disabled
- 0 = Corresponding port C pin configured as input

### 7.4.3 Port C Pulldown Devices

All port C pins can have software programmable pulldown devices enabled or disabled globally by the SWPDI bit in the MOR. These pulldown devices are individually controlled by the write-only pulldown register A (PDRA) shown in Figure 7-3. PDICH controls the upper four pins (PC7–PC4) and PDICL controls the lower four pins (PC3–PC0). Clearing the PDICH or PDICL bits in the PDRA turns on the pulldown devices if the port C pin is an input. Reading the PDRA returns undefined results since it is a write-only register. Reset clears the PDICH and PDICL bits, which turns on all the port C pulldown devices.

### 7.4.4 Port C Logic

Figure 7-15 shows the I/O logic of port C.

When a port C pin is programmed as an output, reading the port bit actually reads the value of the data latch and not the voltage on the pin itself. When a port C pin is programmed as an input, reading the port bit reads the voltage level on the pin. The data latch can always be written, regardless of the state of its DDR bit. Table 7-4 summarizes the operations of the port C pins.

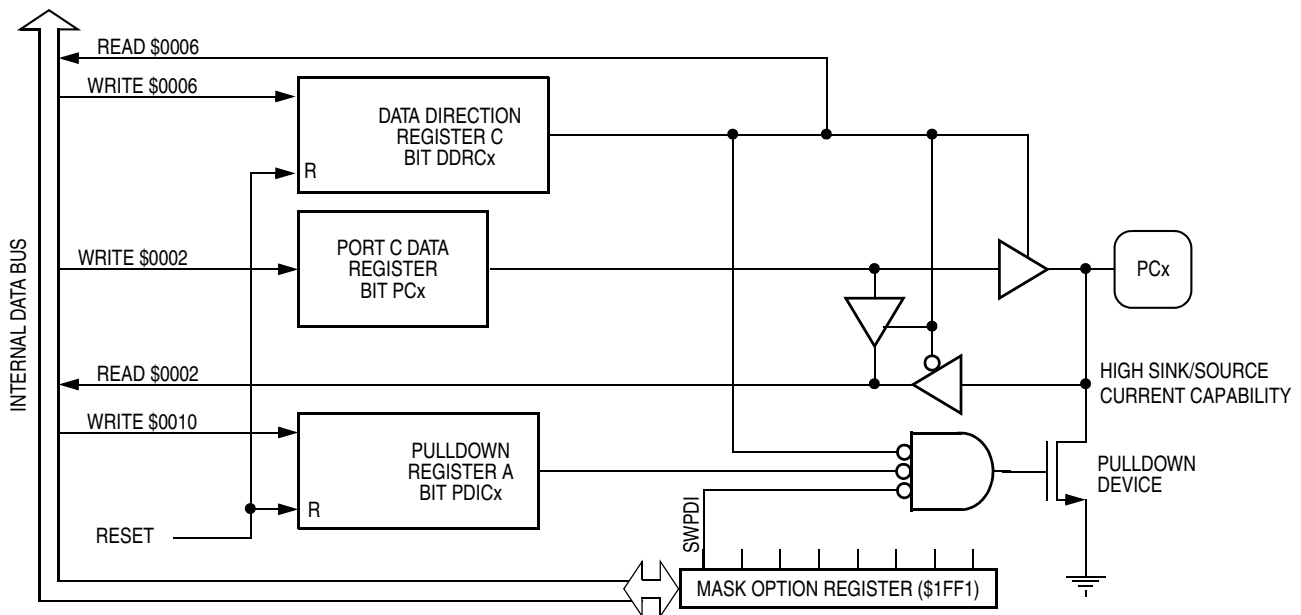

Figure 7-15. Port C I/O Circuit

**Table 7-4. Port C Pin Functions (28-Pin Versions Only)**

Port C Pin(s)	Control Bits				PORTC Access (Pin or Data Register)		Result on Port C Pins	
	SWPDI in MOR	Port C			Read	Write	Pulldown	Pin
		PDICH	PDICL	DDRCx <sup>(1)</sup>				
PC0	0	X <sup>(2)</sup>	0	0	Pin	Data	On	PCx in
PC1	0	X <sup>(2)</sup>	1	0	Pin	Data	Off	PCx in
PC2	1	X	X <sup>(2)</sup>	0	Pin	Data	Off	PCx in
PC3	X <sup>(2)</sup>	X <sup>(2)</sup>	X <sup>(2)</sup>	1	Data	Data	Off	PCx out
PC4	0	0	X <sup>(2)</sup>	0	Pin	Data	On	PCx in
PC5	0	1	X <sup>(2)</sup>	0	Pin	Data	Off	PCx in
PC6	1	X	X <sup>(2)</sup>	0	Pin	Data	Off	PCx in
PC7	X <sup>(2)</sup>	X <sup>(2)</sup>	X <sup>(2)</sup>	1	Data	Data	Off	PCx out

1. DDRC can always be read or written.

2. Don't care

## 7.5 Port Transitions

Glitches and temporary floating inputs can occur if the control bits regarding each port I/O pin are not performed in the correct sequence.

- Do not use read-modify-write instructions on pulldown register A or B.
- Avoid glitches on port pins by writing to the port data register before changing data direction register bits from a logic 0 to a logic 1.
- Avoid a floating port input by clearing its pulldown register bit before changing its data direction register bit from a logic 1 to a logic 0.
- The SWPDI bit in the MOR turns off all port pulldown devices and disables software control of the pulldown devices. Reset has no effect on the pulldown devices when the SWPDI bit is set.
- Two or more output pins of the same port can be connected electrically to provide output currents up to the sum of the maximum specified drive currents as defined in [15.7 DC Electrical Characteristics \(5.0 Vdc\)](#) and [15.8 DC Electrical Characteristics \(3.0 Vdc\)](#). Care must be taken to ensure that all ganged pins always maintain the same output logic value.



# Chapter 8

## Analog Subsystem

### 8.1 Introduction

The analog subsystem of the MC68HC705JJ7/MC68HC705P7 is based on two on-chip voltage comparators and a selectable current charge/discharge function as shown in [Figure 8-1](#).

This configuration provides several features:

- Two independent voltage comparators with external access to both inverting and non-inverting inputs
- One voltage comparator can be connected as a single-slope analog-to-digital (A/D) and the other connected as a single-voltage comparator. The possible single-slope A/D connection provides these features:
  - A/D conversions can use  $V_{DD}$  or an external voltage as a reference with software used to calculate ratiometric or absolute results
  - Channel access of up to four inputs via multiplexer control with independent multiplexer control allowing mixed input connections
  - Access to  $V_{DD}$  and  $V_{SS}$  for calibration
  - Divide by 2 to extend input voltage range
  - Each comparator can be inverted to calculate input offsets.
  - Internal sample and hold capacitor
  - Direct digital output of comparator 1 to the PB4 pin

Voltages are resolved by measuring the time it takes an external capacitor to charge up to the level of the unknown input voltage being measured. The beginning of the A/D conversion time can be started by several means:

- Output compare from the 16-bit programmable timer
- Timer overflow from the 16-bit programmable timer
- Direct software control via a register bit

The end of the A/D conversion time can be captured by these means:

- Input capture in the 16-bit programmable timer
- Interrupt generated by the comparator output
- Software polling of the comparator output using software loop time

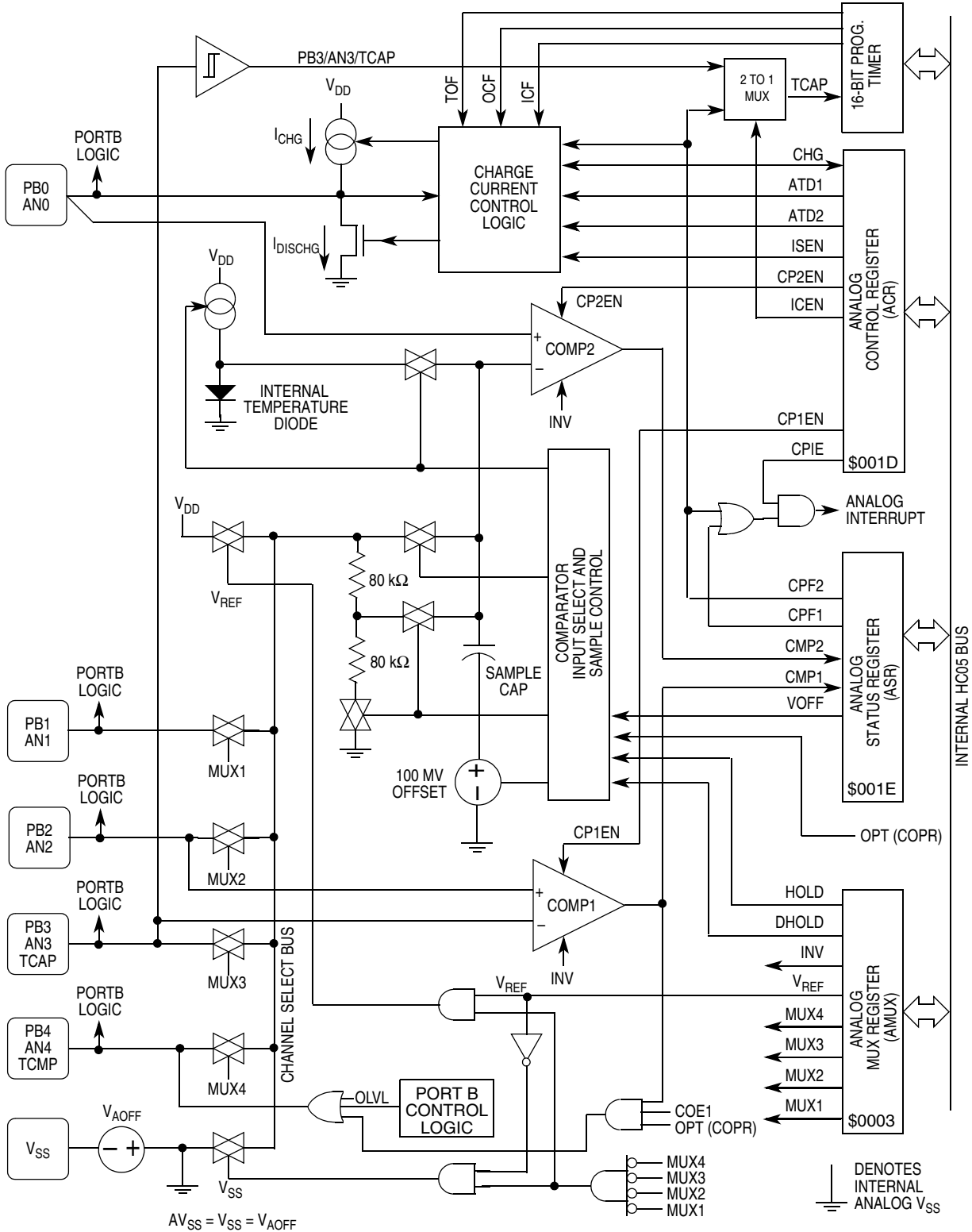

Figure 8-1. Analog Subsystem Block Diagram

## 8.2 Analog Multiplex Register

The analog multiplex register (AMUX) controls the general interconnection and operation. The control bits in the AMUX are shown in [Figure 8-2](#).

Address: \$0003

	Bit 7	6	5	4	3	2	1	Bit 0
Read:	HOLD	DHOLD	INV	VREF	MUX4	MUX3	MUX2	MUX1
Write:								
Reset:	1	0	0	0	0	0	0	0

**Figure 8-2. Analog Multiplex Register (AMUX)**

### HOLD, DHOLD

These read/write bits control the source connection to the negative input of voltage comparator 2 shown in [Figure 8-3](#). This allows the voltage on the internal temperature sensing diode, the channel selection bus, or the divide-by-two channel selection bus to charge the internal sample capacitor and to also be presented to comparator 2. The decoding of these sources is given in [Table 8-1](#).

During the hold case when both the HOLD and DHOLD bits are clear, the VOFF bit in the analog status register (ASR) can offset the  $V_{SS}$  reference on the sample capacitor by approximately 100 mV. This offset source is bypassed whenever the sample capacitor is being charged with either the HOLD or DHOLD bit set. The VOFF bit must be enabled by the OPT bit in the COPR at location \$1FF0.

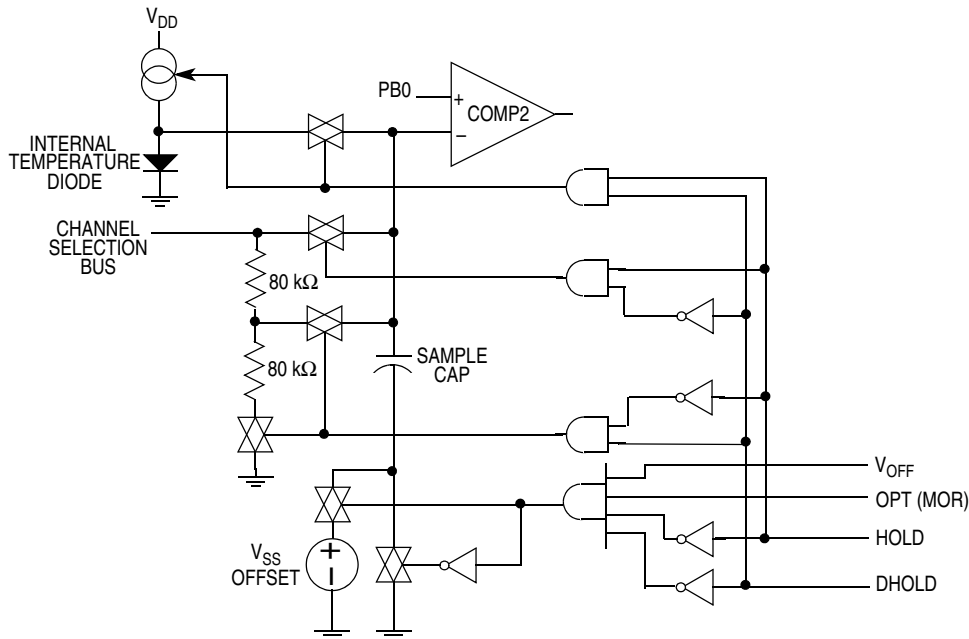

**Figure 8-3. Comparator 2 Input Circuit**

**Table 8-1. Comparator 2 Input Sources**

Case	HOLD (AMUX)	DHOLD (AMUX)	OPT (MOR)	VOFF (ASR)	Voltage Offset	Source To Negative Input of Comparator 2
Hold sample voltage	0	0	0	$\chi^{(1)}$	No	Sample capacitor connected to comparator 2 negative input; very low leakage current.
			1	0		
			1	1	Yes	Sample capacitor connected to comparator 2 negative input; bottom of capacitor offset from $V_{SS}$ by approximately 100 mV, very low leakage current.
Divide input	0	1	$\chi^{(1)}$	$\chi^{(1)}$	No	Signal on channel selection bus is divided by 2 and connected to sample capacitor and comparator 2 negative input
Direct input	1	0	$\chi^{(1)}$	$\chi^{(1)}$	No	Signal on channel selection bus is connected directly to sample capacitor and comparator 2 negative input.
Internal temperature diode	1	1	$\chi^{(1)}$	$\chi^{(1)}$	No	Internal temperature sensing diode connected directly to sample capacitor and comparator 2 negative input.

1. Don't care

During a reset, the HOLD bit is set and the DHOLD bit is cleared, which connects the internal sample capacitor to the channel selection bus. And since a reset also clears the MUX[1:4] bits, then the channel selection bus will be connected to  $V_{SS}$  and the internal sample capacitor will be discharged to  $V_{SS}$  following the reset.

**NOTE**

*When sampling a voltage for later conversion, the HOLD and DHOLD bits should be cleared before making any changes in the MUX channel selection. If the MUX channel and the HOLD/DHOLD are changed on the same write cycle to the AMUX register, the sampled voltage may be altered during the channel switching.*

**INV**

This is a read/write bit that controls the relative polarity of the inherent input offset voltage of the voltage comparators. This bit allows voltage comparisons to be made with both polarities and then averaged together by taking the sum of the two readings and then dividing by 2 (logical shift right).

The polarity of the input offset is reversed by interchanging the internal voltage comparator inputs while also inverting the comparator output. This interchange does not alter the action of the voltage comparator output with respect to its port pins. That is, the output will only go high if the voltage on the positive input (PB2 pin for comparator 1 and PB0 pin for comparator 2) is above the voltage on the respective negative input (PB3 pin for comparator 1 and PB1 pin for comparator 2). This is shown schematically in [Figure 8-4](#). This bit is cleared by a reset of the device.

- 1 = The voltage comparators are internally inverted.
- 0 = The voltage comparators are not internally inverted.

**NOTE**

*The effect of changing the state of the INV bit is to only change the polarity of the input offset voltage. It **does not** change the output phase of the CPF1 or CPF2 flags with respect to the external port pins.*

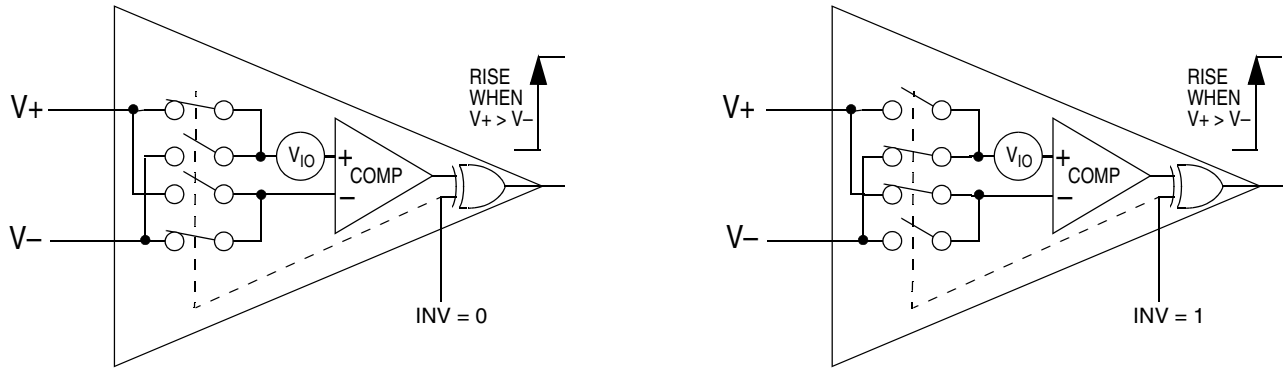
**Figure 8-4. INV Bit Action**
**NOTE**

Either comparator may generate an output flag when the inputs are exchanged due to a change in the state of the INV bit. It is therefore recommended that the INV bit not be changed while waiting for a comparator flag. Further, any changes to the state of the INV bit should be followed by writing a logic 1 to both the CPFR1 and CPFR2 bits to clear any extraneous CPF1 or CPF2 flags that may have occurred.

**VREF**

This read/write bit connects the channel select bus to  $V_{DD}$  for making a reference voltage measurement. It cannot be selected if any of the other input sources to the channel select bus are selected as shown in [Table 8-2](#). This bit is cleared by a reset of the device.

1 = Channel select bus connected to  $V_{DD}$  if all MUX1:4 are cleared.

0 = Channel select bus cannot be connected to  $V_{DD}$ .

**MUX1:4**

These are read/write bits that connect the analog subsystem pins to the channel select bus and voltage comparator 2 for purposes of making a voltage measurement. They can be selected individually or combined with any of the other input sources to the channel select bus as shown in [Table 8-2](#).

**NOTE**

The  $V_{AOFF}$  voltage source shown in [Figure 8-1](#) depicts a small offset voltage generated by the total chip current passing through the package bond wires and lead frame that are attached to the single  $V_{SS}$  pin. This offset raises the internal  $V_{SS}$  reference ( $AV_{SS}$ ) in the analog subsystem with respect to the external  $V_{SS}$  pin. Turning on the  $V_{SS}$  MUX to the channel select bus connects it to this internal  $AV_{SS}$  reference line.

When making A/D conversions, this  $AV_{SS}$  offset gets placed on the external ramping capacitor since the discharge device on the PB0/AN0 pin discharges the external capacitor to the internal  $AV_{SS}$  line. Under these circumstances, the positive input (+) to comparator 2 will always be higher than the negative input (-) until the negative input reaches the  $AV_{SS}$  offset voltage plus any offset in comparator 2.

Therefore, input voltages cannot be resolved if they are less than the sum of the  $AV_{SS}$  offset and the comparator offset, because they will always yield a low output from the comparator.

**Table 8-2. Channel Select Bus Combinations**

Analog Multiplex Register					Channel Select Bus Connected to:					
VREF	MUX4	MUX3	MUX2	MUX1	V <sub>DD</sub>	PB4/AN4/ TCMP	PB3/AN3/ TCAP	PB2/AN2	PB1/AN1	V <sub>SS</sub>
0	0	0	0	0	Hi-Z	Hi-Z	Hi-Z	Hi-Z	Hi-Z	On
X <sup>(1)</sup>	0	0	0	1	Hi-Z	Hi-Z	Hi-Z	Hi-Z	On	Hi-Z
X <sup>(1)</sup>	0	0	1	0	Hi-Z	Hi-Z	Hi-Z	On	Hi-Z	Hi-Z
X <sup>(1)</sup>	0	0	1	1	Hi-Z	Hi-Z	Hi-Z	On	On	Hi-Z
X <sup>(1)</sup>	0	1	0	0	Hi-Z	Hi-Z	On	Hi-Z	Hi-Z	Hi-Z
X <sup>(1)</sup>	0	1	0	1	Hi-Z	Hi-Z	On	Hi-Z	On	Hi-Z
X <sup>(1)</sup>	0	1	1	0	Hi-Z	Hi-Z	On	On	Hi-Z	Hi-Z
X <sup>(1)</sup>	0	1	1	1	Hi-Z	Hi-Z	On	On	On	Hi-Z
X <sup>(1)</sup>	1	0	0	0	Hi-Z	On	Hi-Z	Hi-Z	Hi-Z	Hi-Z
X <sup>(1)</sup>	1	0	0	1	Hi-Z	On	Hi-Z	Hi-Z	On	Hi-Z
X <sup>(1)</sup>	1	0	1	0	Hi-Z	On	Hi-Z	On	Hi-Z	Hi-Z
X <sup>(1)</sup>	1	0	1	1	Hi-Z	On	Hi-Z	On	On	Hi-Z
X <sup>(1)</sup>	1	1	0	0	Hi-Z	On	On	Hi-Z	Hi-Z	Hi-Z
X <sup>(1)</sup>	1	1	0	1	Hi-Z	On	On	Hi-Z	On	Hi-Z
X <sup>(1)</sup>	1	1	1	0	Hi-Z	On	On	On	Hi-Z	Hi-Z
X <sup>(1)</sup>	1	1	1	1	Hi Z	On	On	On	On	Hi Z

1. Don't care

### 8.3 Analog Control Register

The analog control register (ACR) controls the power-up, interrupt, and flag operation. The analog subsystem draws current while it is operating. The resulting power consumption can be reduced by powering down the analog subsystem when not in use (refer to [15.5 Supply Current Characteristics \(V<sub>DD</sub> = 4.5 to 5.5 Vdc\)](#)). This can be done by clearing three enable bits (ISEN, CP1EN, and CP2EN) in the ACR at \$001D. Since these bits are cleared following a reset, the voltage comparators and the charge current source will be powered down following a reset of the device.

The control bits in the ACR are shown in [Figure 8-5](#). All the bits in this register are cleared by a reset of the device.

Address: \$001D

	Bit 7	6	5	4	3	2	1	Bit 0
Read:	CHG	ATD2	ATD1	ICEN	CPIE	CP2EN	CP1EN	ISEN
Write:								
Reset:	0	0	0	0	0	0	0	0

**Figure 8-5. Analog Control Register (ACR)**

### CHG

The CHG enable bit allows direct control of the charge current source and the discharge device and also reflects the state of the discharge device. This bit is cleared by a reset of the device.

1 = If the ISEN bit is also set, the charge current source is sourcing current out of the PB0/AN0 pin.

Writing a logic 1 enables the charging current out of the PB0/AN0 pin.

0 = The discharge device is sinking current into the PB0/AN0 pin. Writing a logic 0 disables the charging current and enables the discharging current into the PB0/AN0 pin, if the ISEN bit is also set.

### ATD1–ATD2

The ATD1–ATD2 enable bits select one of the four operating modes used for making A/D conversions via the single-slope method. These four modes are given in [Table 8-3](#). These bits have no effect if the ISEN enable bit is cleared. These bits are cleared by a reset of the device and thereby return the analog subsystem to the manual A/D conversion method.

**Table 8-3. A/D Conversion Options**

A/D Option Mode	Charge Control	A/D Options				Current Flow to/from PB0/AN0
		ISEN	ATD2	ATD1	CHG	
Disabled	Current source and discharge disabled	0	X	X	X	Current control disabled, no source or sink current
		1	0	0	1	Begin sourcing current when the CHG bit is set and continue to source current until the CHG bit is cleared.
		1	1	0	1	The CHG bit remains set until the next time ICF occurs.
3	Automatic charge and discharge (OCF–ICF) synchronized to timer	1	1	1	0	The CHG bit remains cleared until the next time OCF occurs.
		1	1	1	1	The CHG bit remains set until the next time ICF occurs.

### ICEN

This is a read/write bit that enables a voltage comparison to trigger the input capture register of the programmable timer when the CPF2 flag bit is set. Therefore, an A/D conversion could be started by receiving an OCF or TOF from the programmable timer and then terminated when the voltage on the external ramping capacitor reaches the level of the unknown voltage. The time of termination will be stored in the 16-bit buffer located at \$0014 and \$0015. This bit is automatically set whenever mode 2 or 3 is selected by setting the ATD2 control bit. This bit is cleared by a reset of the device.

- 1 = Connects the CPF2 flag bit to the timer input capture register
- 0 = Connects the PB3/AN3 pin to the timer input capture register

#### NOTE

*For the input capture to occur when the output of comparator 2 goes high, the IEDG bit in the TCR must also be set.*

*When the ICEN bit is set, the input capture function of the programmable timer is not connected to the PB3/AN3/TCAP pin but is driven by the CPF2 output flag from comparator 2. To return to capturing times from external events, the ICEN bit must first be cleared before the timed event occurs.*

### CP1E

This is a read/write bit that enables an analog interrupt when either of the CPF1 or CPF2 flag bits is set to a logic 1. This bit is cleared by a reset of the device.

- 1 = Enables analog interrupts when comparator flag bits are set
- 0 = Disables analog interrupts when comparator flag bits are set

#### NOTE

*If both the ICEN and CP1E bits are set, they will both generate an interrupt by different paths. One will be the programmable timer interrupt due to the input capture and the other will be the analog interrupt due to the output of comparator 2 going high. In this case, the input capture interrupt will be entered first due to its higher priority. The analog interrupt will then need to be serviced even if the comparator 2 output has been reset or the input capture flag (ICF) has been cleared.*

### CP2EN

The CP2EN enable bit controls power to voltage comparator 2 in the analog subsystem. Powering down a comparator will drop the supply current. This bit is cleared by a reset of the device.

- 1 = Writing a logic 1 powers up voltage comparator 2.
- 0 = Writing a logic 0 powers down voltage comparator 2.

#### NOTE

*Voltage comparators power up slower than digital logic and their outputs may go through indeterminate states which might set their respective flags (CPF1, CPF2). It is therefore recommended to power up the charge current source first (ISEN), then to power up any comparators, and finally clear the flag bits by writing a logic 1 to the respective CPFR1 or CPFR2 bits in the ACR.*

### CP1EN

The CP1EN enable bit will power down the voltage comparator 1 in the analog subsystem. Powering down a comparator will drop the supply current. This bit is cleared by a reset of the device.

- 1 = Writing a logic 1 powers up voltage comparator 1
- 0 = Writing a logic 0 powers down voltage comparator 1

### ISEN

The ISEN enable bit will power down the charge current source and disable the discharge device in the analog subsystem. Powering down the current source will drop the supply current by about 200  $\mu$ A. This bit is cleared by a reset of the device.

1 = Writing a logic 1 powers up the ramping current source and enables the discharge device on the PB0/AN0 pin.

0 = Writing a logic 0 powers down the ramping current source and disables the discharge device on the PB0/AN0 pin.

#### NOTE

*The analog subsystem has support circuitry which draws current. This current will be powered down if both comparators and the charge current source are powered down (ISEN, CP1EN, and CP2EN all cleared). Powering up either comparator or the charge current source will activate the support circuitry.*

## 8.4 Analog Status Register

The analog status register (ASR) contains status and control of the comparator flag bits. These bits in the ASR are shown in [Figure 8-6](#). All the bits in this register are cleared by a reset of the device.

Address: \$001E

	Bit 7	6	5	4	3	2	1	Bit 0
Read:	CPF2	CPF1	0	0	COE1	VOFF	CMP2	CMP1
Write:			CPFR2	CPFR1				R
Reset:	0	0	0	0	0	0	0	0

  = Unimplemented
 R = Reserved

**Figure 8-6. Analog Status Register (ASR)**

### CPF2

This read-only flag bit is edge sensitive to the rising output of comparator 2. It is set when the voltage on the PB0/AN0 pin rises above the voltage on a sample capacitor which creates a positive edge on the output of comparator 2, regardless of the state of the INV bit in the AMUX register. This bit is reset by writing a logic 1 to the CPFR2 reset bit in the ASR. This bit is cleared by a reset of the device.

1 = A positive transition on the output of comparator 2 has occurred since the last time the CPF2 flag has been cleared.

0 = A positive transition on the output of comparator 2 has **not** occurred since the last time the CPF2 flag has been cleared.

### CPF1

This read-only flag bit is edge sensitive to the rising output of comparator 1. It is set when the voltage on the PB2/AN2 pin rises above the voltage on the PN3/AN3/TCAP pin which creates a positive edge on the output of comparator 1, regardless of the state of the INV bit in the AMUX register. This bit is reset by writing a logic 1 to the CPFR1 reset bit in the ASR. This bit is cleared by a reset of the device.

1 = A positive transition on the output of comparator 1 has occurred since the last time the CPF1 flag has been cleared.

0 = A positive transition on the output of comparator 1 has **not** occurred since the last time the CPF1 flag has been cleared.

### CPFR2

Writing a logic 1 to this write-only flag clears the CPF2 flag in the ASR. Writing a logic 0 to this bit has no effect. Reading the CPFR2 bit will return a logic 0. By default, this bit looks cleared following a reset of the device.

- 1 = Clears the CPF2 flag bit
- 0 = No effect

### CPFR1

Writing a logic 1 to this write-only flag clears the CPF1 flag in the ASR. Writing a logic 0 to this bit has no effect. Reading the CPFR1 bit will return a logic 0. By default, this bit looks cleared after a reset of the device.

- 1 = Clears the CPF1 flag bit
- 0 = No effect

#### NOTE

*The CPFR1 and CPFR2 bits should be written with logic 1s following a power-up of either comparator. This will clear out any latched CPF1 or CPF2 flag bits which might have been set during the slower power-up sequence of the analog circuitry.*

*If both inputs to a comparator are above the maximum common-mode input voltage ( $V_{DD} - 1.5 V$ ), the output of the comparator is indeterminate and may set the comparator flag. Applying a reset to the device may only temporarily clear this flag as long as both inputs of a comparator remain above the maximum common-mode input voltages.*

### VOFF

This read-write bit controls the addition of an offset voltage to the bottom of the sample capacitor. It is not active unless the OPT bit in the COPR at location \$1FF0 is set. Any reads of the VOFF bit location return a logic 0 if the OPT bit is clear. During the time that the sample capacitor is connected to an input (either HOLD or DHOLD set), the bottom of the sample capacitor is connected to  $V_{SS}$ . The VOFF bit is cleared by a reset of the device. For more information, see [8.10 Sample and Hold](#).

- 1 = Enables approximately 100 mV offset to be added to the sample voltage when both the HOLD and DHOLD control bits are cleared
- 0 = Connects the bottom of the sample capacitor to  $V_{SS}$

### COE1

This read-write bit controls the output of comparator 1 to the PB4 pin. It is not active unless the OPT bit in the COPR at location \$1FF0 is set. Any reads of the COE1 bit location return a logic 0 if the OPT bit is clear. The COE1 bit is cleared by a reset of the device.

- 1 = Enables the output of comparator 1 to be ORed with the PB4 data bit and OLVL bit, if the DDRB4 bit is also set
- 0 = Disables the output of comparator 1 from affecting the PB4 pin

### CMP2

This read-only bit shows the state of comparator 2 during the time that the bit is read. This bit is therefore the current state of the comparator without any latched history. The CMP2 bit will be high if the voltage on the PB0/AN0 pin is greater than the voltage on the PB1/AN1 pin, regardless of the state of the INV bit in the AMUX register. Since a reset disables comparator 2, this bit returns a logic 0 following a reset of the device.

- 1 = The voltage on the positive input on comparator 2 is higher than the voltage on the negative input of comparator 2.
- 0 = The voltage on the positive input on comparator 2 is lower than the voltage on the negative input of comparator 2.

**CMP1**

This read-only bit shows the state of comparator 1 during the time that the bit is read. This bit is therefore the current state of the comparator without any latched history. The CMP1 bit will be high if the voltage on the PB2/AN2 pin is greater than the voltage on the PB3/AN3/TCAP pin, regardless of the state of the INV bit in the AMUX register. Since a reset disables comparator 1, this bit returns a logic 0 following a reset of the device.

- 1 = The voltage on the positive input on comparator 1 is higher than the voltage on the negative input of comparator 1.
- 0 = The voltage on the positive input on comparator 1 is lower than the voltage on the negative input of comparator 1.

**8.5 A/D Conversion Methods**

The control bits in the ACR provide various options to charge or discharge current through the PB0/AN0 pin to perform single-slope A/D conversions using an external capacitor from the PB0/AN0 pin to  $V_{SS}$  as shown in Figure 8-7. The various A/D conversion triggering options are given in Table 8-3.

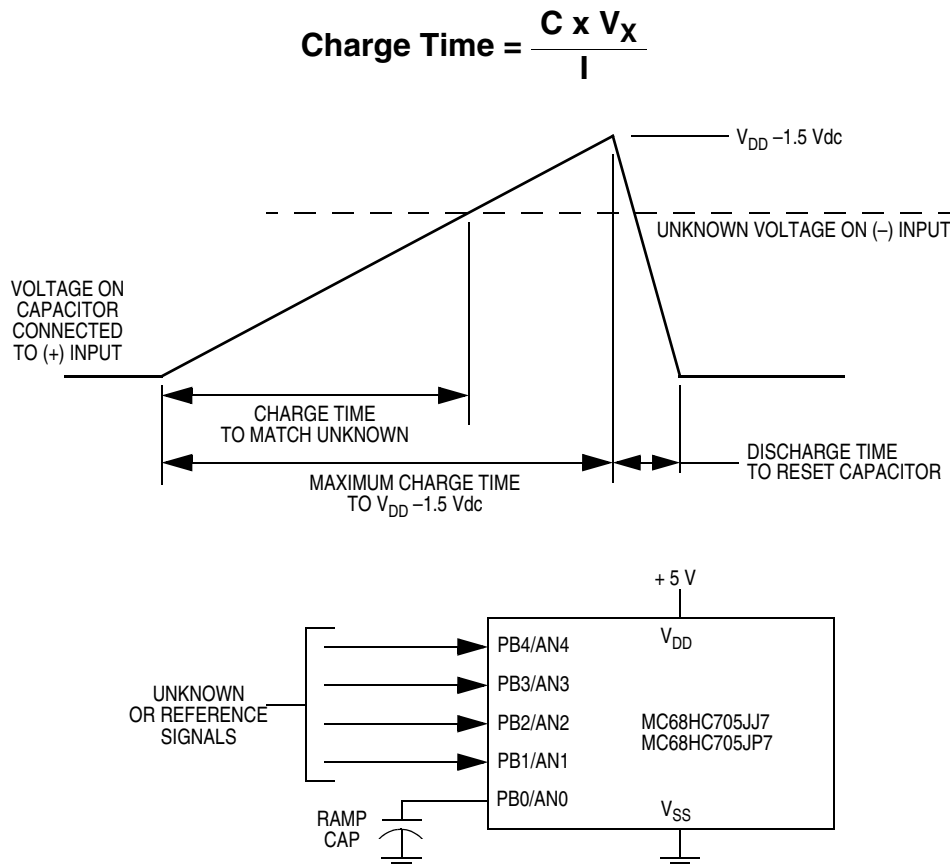

**Figure 8-7. Single-Slope A/D Conversion Method**

The top three bits of the ACR control the charging and discharging current into or out of the PB0/AN0 pin. These three bits will have no effect on the PB0/AN0 pin if the ISEN enable bit is cleared. Any clearing of the ISEN bit will immediately disable both the charge current source and the discharge device. Since all

## Analog Subsystem

these bits and the ISEN bit are cleared when the device is reset, the MC68HC705JJ7/MC68HC705JP7 starts with the charge and discharge function disabled.

The length of time required to reach the maximum voltage to be measured and the speed of the time counting mechanism will determine the resolution of the reading. The time to ramp the external capacitor voltage to match the maximum voltage is dependent on:

- Charging current to external capacitor
- Value of the external capacitor
- Clock rate for timing function
- Any prescaling of the clock to the timing function
- Desired resolution

The charging behavior is described by the general equation:

$$t_{\text{CHG}} = C_{\text{EXT}} \times V_X / I_{\text{CHG}}$$

### Where:

$t_{\text{CHG}}$  = Charge time (seconds)

$C_{\text{EXT}}$  = Capacitance ( $\mu\text{F}$ )

$V_X$  = Unknown voltage (volts)

$I_{\text{CHG}}$  = Charge current ( $\mu\text{A}$ )

Since the MCU can measure time in a variety of ways, the resolution of the conversion will depend on the length of the time keeping function and its prescaling to the oscillator frequency ( $f_{\text{OSC}}$ ). Therefore, the charge time also equals:

$$t_{\text{CHG}} = P \times N / f_{\text{OSC}}$$

### Where:

P = Prescaler value ( $\div 2, \div 4, \div 8$ , etc.)

N = Number of counts during charge time

$f_{\text{OSC}}$  = Oscillator clock frequency (Hz)

### NOTE

*Noise on the system ground or the external ramping capacitor can cause the comparator to trip prematurely. Therefore, in any given application it is best to use the fastest possible ramp rate (shortest charge time).*

The previous two equations for the charge time,  $t_{\text{CHG}}$ , can be combined to form the following expression for the full scale count ( $N_{\text{FS}}$ ) of the measured time versus the full scale unknown voltage ( $V_{\text{FS}}$ ):

$$N_{\text{FS}} = C_{\text{EXT}} \times V_{\text{FS}} \times f_{\text{OSC}} / (P \times I_{\text{CHG}})$$

Since a given timing method has a fixed charge current and prescaler, then the variation in the resultant count for a given unknown voltage is mainly dependent on the operating frequency and the capacitance value used. The desired external capacitance for a given voltage range,  $f_{\text{OSC}}$ , conversion method, and resolution is defined as:

$$C_{\text{EXT}} = N_{\text{FS}} \times P \times I_{\text{CHG}} / (V_{\text{FS}} \times f_{\text{OSC}})$$

### NOTE

*The value of any capacitor connected directly to the PB0/AN0 pin should be limited to less than 2 microfarads. Larger capacitances will create high discharge currents which may damage the device or create signal noise.*

The full scale voltage range for a given capacitance,  $f_{OSC}$ , conversion method, and resolution is defined as:

$$V_{FS} = N_{FS} \times P \times I_{CHG} / (C_{EXT} \times f_{OSC})$$

Once charged to a given voltage, a finite amount of time will be required to discharge the capacitor back to its start voltage at  $V_{SS}$ . This discharge time will be solely based on the value of capacitance used and the sinking current of the internal discharge device. To allow a reasonable time for the capacitor to return to  $V_{SS}$  levels, the discharge time should last about 10 milliseconds per microfarad of capacitance attached to the PBO pin. If the total charge/discharge cycle time is critical, then the discharge time should be at least 1/10 of the most recent charge time. Shorter discharge times may be used if lesser accuracy in the voltage measurement is acceptable.

**NOTE**

*Sufficient time should be allowed to discharge the external capacitor or subsequent charge times will be shortened with resultant errors in timing conversion.*

Table 8-4 gives the range of values of each parameter in the A/D timing conversion and Table 8-5 gives some A/D conversion examples for several bit resolutions.

The mode selection bits in the ACR allow four methods of single-slope A/D conversion. Each of these methods is shown in Figure 8-8 through Figure 8-11 using the signal names and parameters given in Table 8-4.

- Manual start and stop (mode 0) [Figure 8-8](#)
- Manual start and automatic discharge (mode 1) [Figure 8-9](#)
- Automatic start and stop from TOF to ICF (mode 2) [Figure 8-10](#)
- Automatic start and stop from OCF to ICF (mode 3) [Figure 8-11](#)

**Table 8-4. A/D Conversion Parameters**

Name	Function	Min	Typ	Max	Units
$V_X$	Unknown voltage on channel selection bus	$V_{SS}$	—	$V_{DD} - 1.5$	V
$V_{MAX}$	Maximum charging voltage on external capacitor	—	—	$V_{DD} - 1.5$	V
$I_{CHG}$	Charging current on external ramping capacitor $V_{DD} = 3$ Vdc $V_{DD} = 5$ Vdc	Refer to <a href="#">15.9 Analog Subsystem Characteristics (5.0 Vdc)</a> and <a href="#">15.10 Analog Subsystem Characteristics (3.0 Vdc)</a>			
$I_{DIS}$	Discharge current on external ramping capacitor	Refer to <a href="#">15.9 Analog Subsystem Characteristics (5.0 Vdc)</a> and <a href="#">15.10 Analog Subsystem Characteristics (3.0 Vdc)</a>			
$t_{CHG}$	Time to charge external capacitor (100 kHz < $f_{OSC}$ < 4.0 MHz) 4-bit result 6-bit result 8-bit result 10-bit result 12-bit result	0.032 0.128 0.512 2.048 8.192	0.128 0.512 2.048 8.196 32.768	2.56 10.24 40.96 120 <sup>(1)</sup> 120 <sup>(1)</sup>	ms
$t_{DIS}$	Time to discharge external capacitor, $C_{EXT}$	—	5	10	ms/ $\mu$ F
$C_{EXT}$	Capacitance of external ramping capacitor	0.0001	0.1	2.0	$\mu$ F
N	Number of counts for $I_{CHG}$ to charge $C_{EXT}$ to $V_X$	1	1024	65536	Counts

Continued on next page

**Table 8-4. A/D Conversion Parameters (Continued)**

Name	Function	Min	Typ	Max	Units
P	Prescaler into timing function ( $\div P$ )	8	8	8	$\div P$
	Using core timer	8	8	8	
	Using 16-bit programmable timer Using software loops	24	User defined	User defined	
$f_{OSC}$	Clock source frequency (excluding any prescaling)	Refer to <a href="#">15.11 Control Timing (5.0 Vdc)</a> and <a href="#">15.12 Control Timing (3.0 Vdc)</a>			

1. Limited by requirement for  $C_{EXT}$  to be less than 2.0  $\mu F$

**Table 8-5. Sample Conversion Timing ( $V_{DD} = 5.0 Vdc$ )**

Bits	Counts	$V_X$ (Vdc)	A/D Method	Clock Source	$f_{OSC}$ (MHz)	$t_{CHG}$ (ms)	$C_{EXT}$ ( $\mu F$ )
4	16	3.5	Software loop (12 bus cycles) (24 $f_{OSC}$ cycles) Mode 0 or 1 (manual)	Low-power oscillator	0.1	3.840	0.110
				External pin oscillator	1.0	0.384	0.011
					2.0	0.192	0.006
				4.0	0.096	0.003	
4	16	3.5	Programmable timer (prescaler = 8) Mode 2 or 3 (TOF $\geq$ ICF or OCF $\geq$ ICF)	Low-power oscillator	0.1	1.280	0.037
				External pin oscillator	1.0	0.128	0.004
					2.0	0.064	0.002
				4.0	0.032	0.001	
6	64	3.5	Software loop (12 bus cycles) (24 $f_{OSC}$ cycles) Mode 0 or 1 (manual)	Low-power oscillator	0.1	15.36	0.439
				External pin oscillator	1.0	1.536	0.044
					2.0	0.768	0.022
				4.0	0.384	0.011	
6	64	3.5	Programmable timer (prescaler = 8) Mode 2 or 3 (TOF $\geq$ CF or OCF $\geq$ ICF)	Low-power oscillator	0.1	5.120	0.585
				External pin oscillator	1.0	0.512	0.059
					2.0	0.256	0.029
				4.0	0.128	0.015	
8	256	3.5	Software loop (12 bus cycles) (24 $f_{OSC}$ cycles) Mode 0 or 1 (manual)	Low-power oscillator	0.1	61.44	1.755
				External pin oscillator	1.0	6.144	0.176
					2.0	3.072	0.088
				4.0	1.536	0.044	
8	256	3.5	Programmable timer (prescaler = 8) Mode 2 or 3 (TOF $\geq$ CF or OCF $\geq$ ICF)	Low-power oscillator	0.1	20.48	0.585
				External pin oscillator	1.0	2.048	0.059
					2.0	1.024	0.029
				4.0	0.512	0.015	
10	1024	3.5	Programmable timer (prescaler = 8) Mode 2 or 3 (TOF $\geq$ ICF or OCF $\geq$ ICF)	Low-power oscillator	0.1	Note 1	Note 1
				External pin oscillator	1.0	8.192	0.234
					2.0	4.096	0.117
				4.0	2.048	0.059	
12	4096	3.5	Programmable timer (prescaler = 8) Mode 2 or 3 (TOF $\geq$ ICF or OCF $\geq$ ICF)	Low-power oscillator	0.1	Note 1	Note 1
				External pin oscillator	1.0	32.768	0.936
					2.0	16.384	0.468
				4.0	8.192	0.234	

1. Not usable as the value of  $C_{EXT}$  would be greater than 2.0  $\mu F$

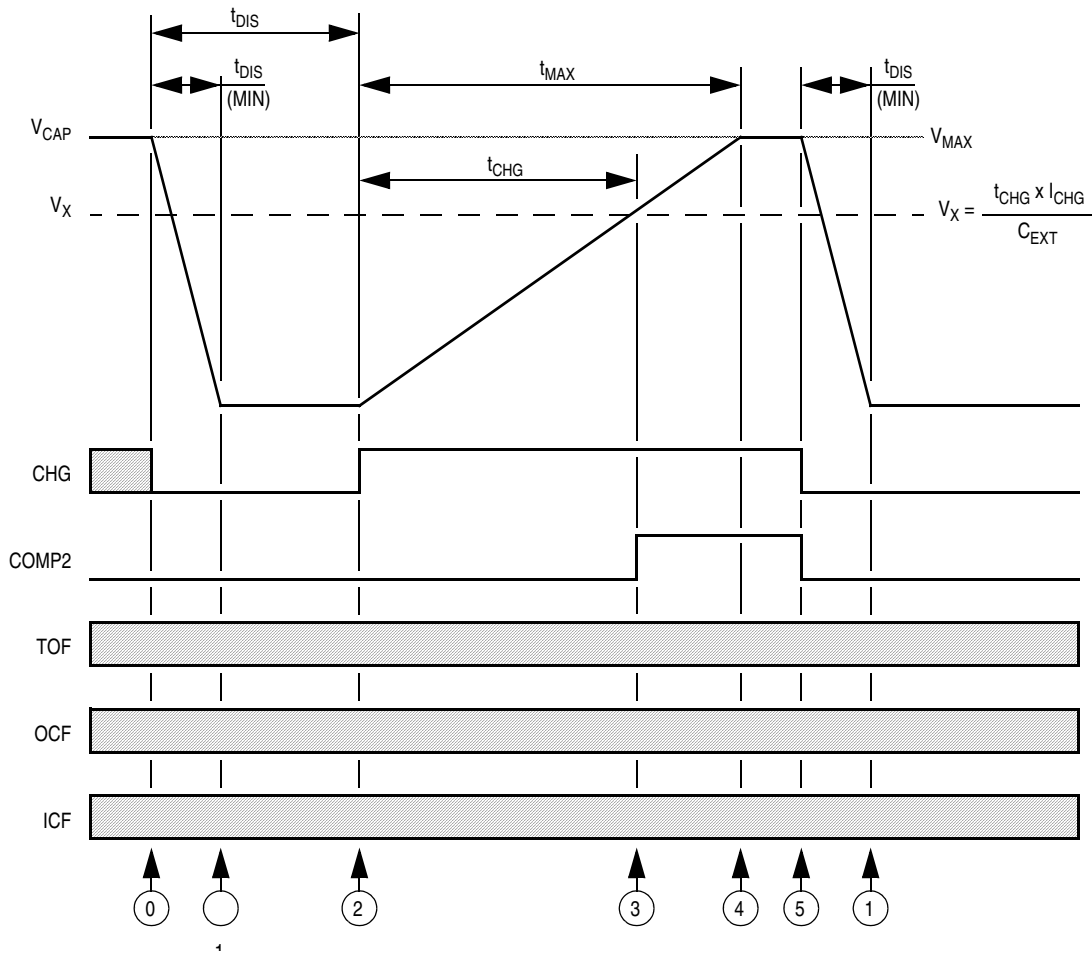

Point	Action	Software/Hardware Action	Dependent Variable(s)
0	Begin initial discharge and select mode 0 by clearing the CHG, ATD2, and ATD1 control bits in the ACR.	Software write	Software
1	$V_{CAP}$ falls to $V_{SS}$ .	Wait out minimum $t_{DIS}$ time.	$V_{MAX}$ , $I_{DIS}$ , $C_{EXT}$
2	Stop discharge and begin charge by setting CHG control bit in ACR.	Software write	Software
3	$V_{CAP}$ rises to $V_X$ and comparator 2 output trips, setting CPF2 and CMP2.	Wait out $t_{CHG}$ time.	$V_X$ , $I_{CHG}$ , $C_{EXT}$
4	$V_{CAP}$ reaches $V_{MAX}$ .	None	$V_{MAX}$ , $I_{CHG}$ , $C_{EXT}$
5	Begin next discharge by clearing the CHG control bit in the ACR. Reset CPF2 by writing a 1 to CPFR2.	Software write	Software

Figure 8-8. A/D Conversion — Full Manual Control (Mode 0)

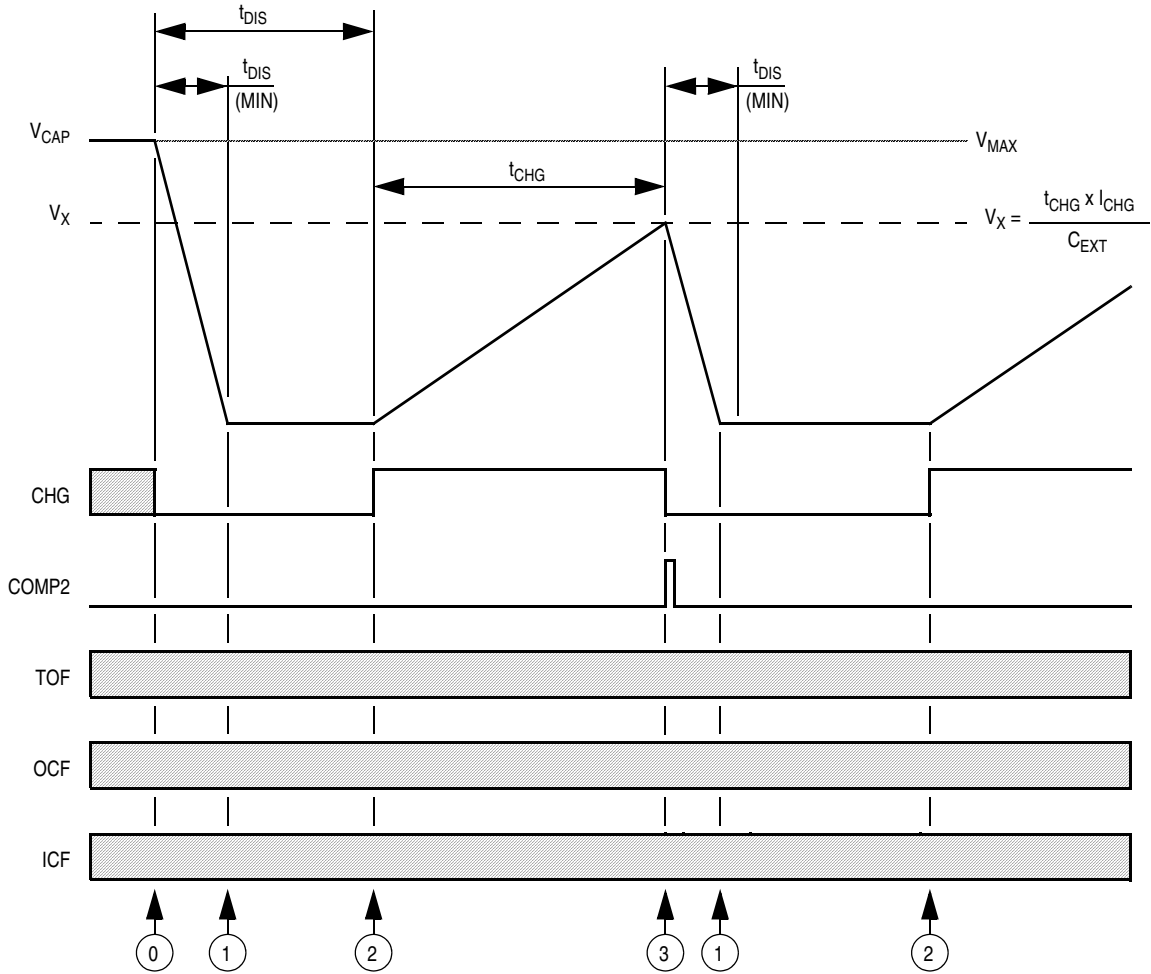

Point	Action	Software/Hardware Action	Dependent Variable(s)
0	Begin initial discharge and select mode 1 by clearing CHG and ATD2 and setting ATD1 in the ACR.	Software write	Software
1	$V_{CAP}$ falls to $V_{SS}$ .	Wait out minimum $t_{DIS}$ time.	$V_{MAX}$ , $I_{DIS}$ , $C_{EXT}$
2	Stop discharge and begin charge by setting CHG control bit in ACR.	Software write	Software
3	$V_{CAP}$ rises to $V_X$ and comparator 2 output trips, setting CPF2 and CMP2, which clears CHG control bit in the ACR. Reset CPF2 by writing a 1 to CPFR2.	Wait out $t_{CHG}$ time. CPF2 clears CHG control bit.	$V_X$ , $I_{CHG}$ , $C_{EXT}$

**Figure 8-9. A/D Conversion — Manual/Auto Discharge Control (Mode 1)**

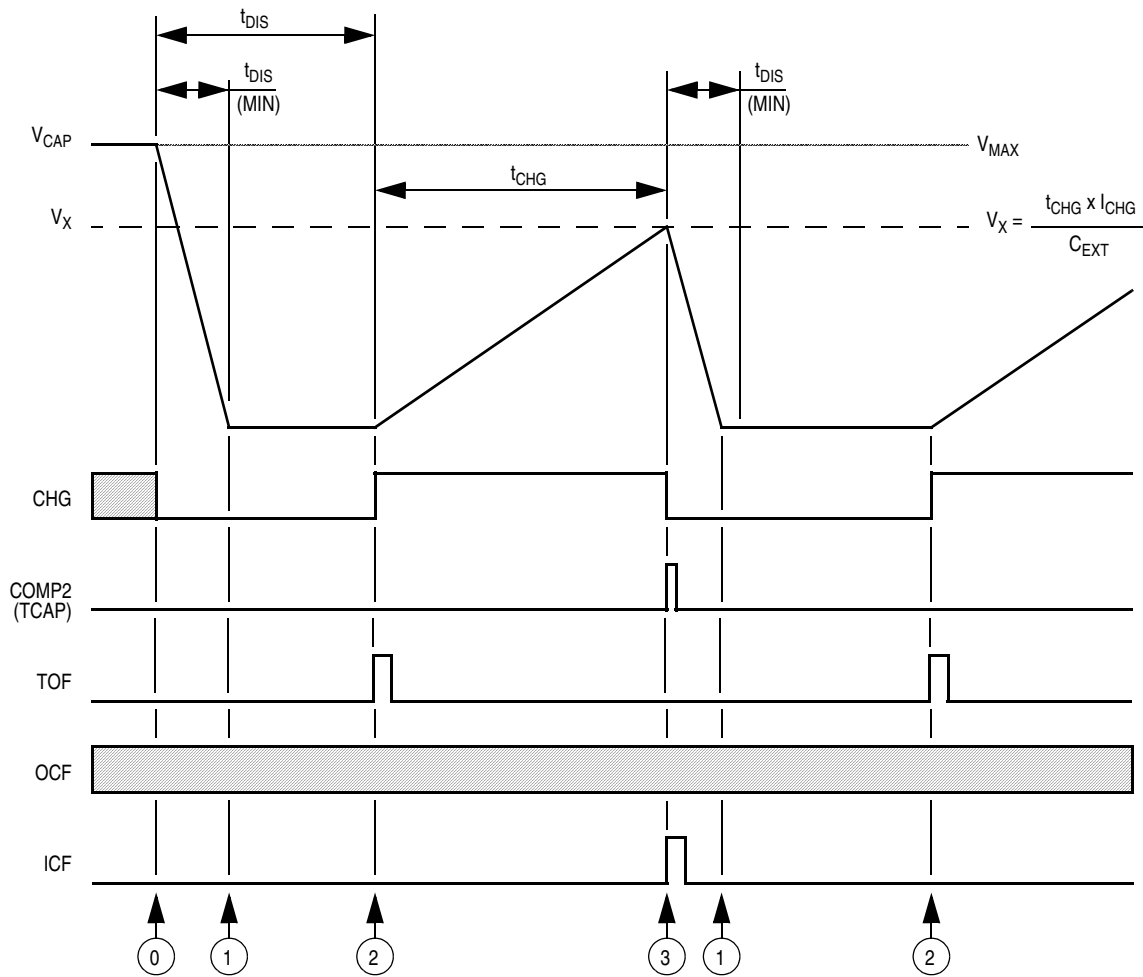

Point	Action	Software/Hardware Action	Dependent Variable(s)
0	Begin initial discharge and select mode 2 by clearing CHG and ATD1 and setting ATD2 in the ACR. Also set ICEN bit in ACR and IEDG bit in TCR.	Software write	Software
1	$V_{CAP}$ falls to $V_{SS}$ .	Wait out minimum $t_{DIS}$ time.	$V_{MAX}$ , $I_{DIS}$ , $C_{EXT}$
2	Stop discharge and begin charge when the next TOF sets the CHG control bit in the ACR.	Timer TOF sets the CHG control bit in the ACR.	Free-running timer counter overflow, $f_{OSC}$
3	$V_{CAP}$ rises to $V_X$ and comparator 2 output trips, setting CPF2 and CMP2, which causes an ICF from the timer and clears the CHG control bit in ACR. Must clear CPF2 to trap next CPF2 flag.	Wait out $t_{CHG}$ time. Timer ICF clears the CHG control bit in the ACR.	$V_X$ , $I_{CHG}$ , $C_{EXT}$

Figure 8-10. A/D Conversion — TOF/ICF Control (Mode 2)

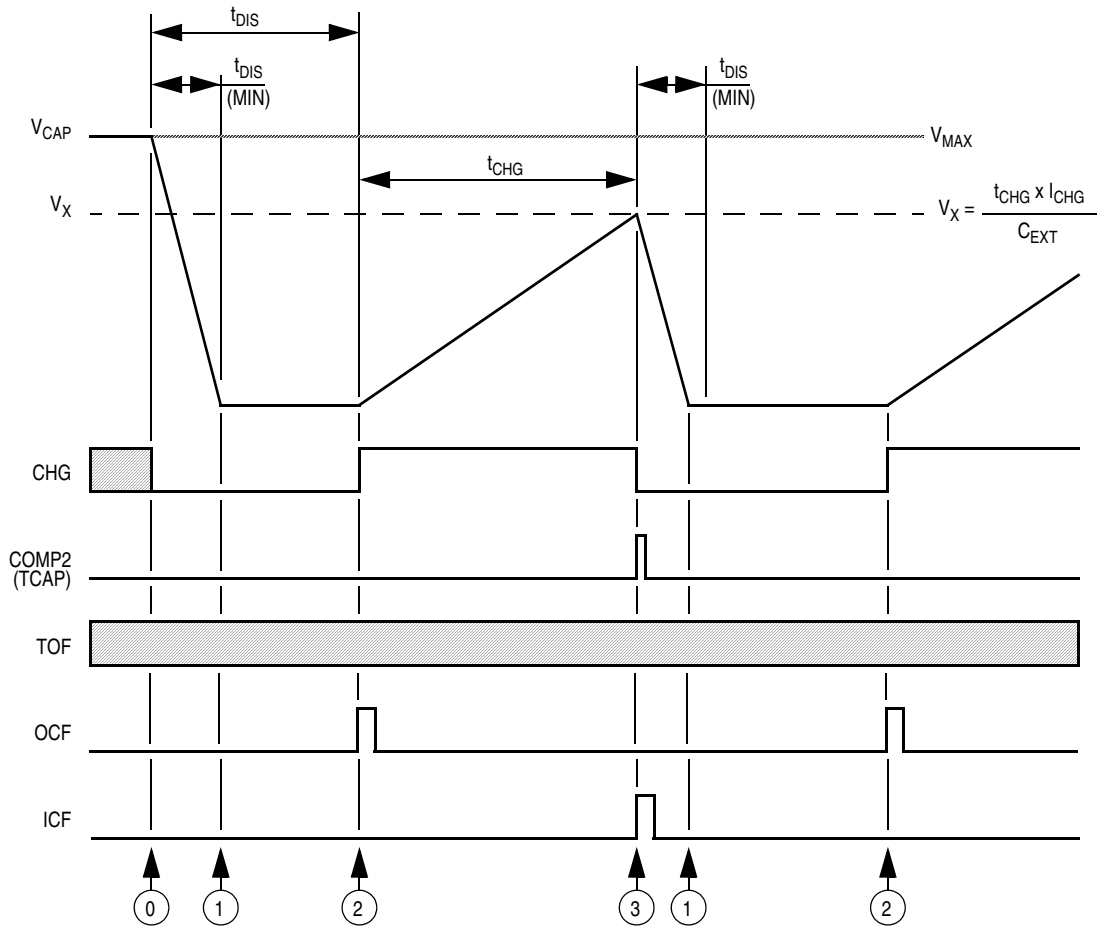

Point	Action	Software/Hardware Action	Dependent Variable(s)
0	Begin initial discharge and select mode 3 by clearing CHG and setting ATD2 and ATD1 in the ACR. Also set ICEN bit in ACR and IEDG bit in TCR.	Software write	Software
1	$V_{CAP}$ falls to $V_{SS}$ . Set timer output compare registers (OCRH and OCRL) to desired charge start time.	Wait out minimum $t_{DIS}$ time. Software write to OCRH, OCRL	$V_{MAX}$ , $I_{DIS}$ , $C_{EXT}$ , software
2	Stop discharge and begin charge when the next OCF sets the CHG control bit in the ACR.	Timer OCF sets the CHG control bit in the ACR.	Free-running timer output compare, $f_{OSC}$
3	$V_{CAP}$ rises to $V_X$ and comparator 2 output trips, setting CPF2 and CMP2, which causes an ICF from the timer and clears the CHG control bit in ACR. Must clear CPF2 to trap next CPF2 flag. Load next OCF.	Wait out $t_{CHG}$ time. Timer ICF clears the CHG control bit in the ACR.	$V_X$ , $I_{CHG}$ , $C_{EXT}$

Figure 8-11. A/D Conversion — OCF/ICF Control (Mode 3)

## 8.6 Voltage Measurement Methods

The methods for obtaining a voltage measurement can use software techniques to express these voltages as absolute or ratiometric readings.

In most applications the external capacitor, the clock source, the reference voltage, and the charging current may vary between devices and with changes in supply voltage or ambient temperature. All of these variations must be considered when determining the desired resolution of the measurement. The maximum and minimum extremes for the full scale count will be:

$$N_{FSMIN} = C_{EXTMIN} \times V_{FSMIN} \times f_{OSCMIN} / (P \times I_{CHGMAX})$$

$$N_{FSMAX} = C_{EXTMAX} \times V_{FSMAX} \times f_{OSCMAX} / (P \times I_{CHGMIN})$$

The minimum count should be the desired resolution, and the counting mechanism must be capable of counting to the maximum. The final scaling of the count will be by a math routine which calculates:

$$V_X = V_{REF} \times (N_X - N_{OFF}) / (N_{REF} - N_{OFF})$$

Where:

$V_{REF}$  = Known reference voltage

$V_X$  = Unknown voltage between  $V_{SS}$  and  $V_{REF}$

$N_X$  = Conversion count for unknown voltage

$N_{REF}$  = Conversion count for known reference voltage ( $V_{REF}$ )

$N_{OFF}$  = Conversion count for minimum reference voltage ( $V_{SS}$ )

When  $V_{REF}$  is a stable voltage source such as a zener or other reference source, then the unknown voltage will be determined as an absolute reading. If  $V_{REF}$  is the supply source to the device ( $V_{DD}$ ), then the unknown voltage will be determined as a ratio of  $V_{DD}$ , or a ratiometric reading.

If the unknown voltage applied to the comparator is greater than its common-mode range ( $V_{DD} - 1.5$  volts), then the external capacitor will try to charge to the same level. This will cause both comparator inputs to be above the common-mode range and the output of the comparator will be indeterminate. In this case the comparator output flags may also be set even if the actual voltage on the positive input (+) is less than the voltage on the negative input (-). All A/D conversion methods should have a maximum time check to determine if this case is occurring.

Once the maximum timeout detection has been made, the state of the comparator outputs can be tested to determine the situation. However, such tests should be carefully designed when using modes 1, 2, or 3 as these modes cause the immediate automatic discharge of the external ramping capacitor before any software check can be made of the output state of comparator 2.

### NOTE

*All A/D conversion methods should include a test for a maximum elapsed time to detect error cases where the inputs may be outside of the design specification.*

## 8.6.1 Absolute Voltage Readings

The absolute value of a voltage measurement can be calculated in software by first taking a reference reading from a fixed source and then comparing subsequent unknown voltages to that reading as a percentage of the reference voltage multiplied times the known reference value.

The accuracy of absolute readings will depend on the error sources taken into account using the features of the analog subsystem and appropriate software as described in [Table 8-6](#). As can be seen from this table, most of the errors can be reduced by frequent comparisons to a known voltage, use of the inverted comparator inputs, and averaging of multiple samples.

### 8.6.1.1 Internal Absolute Reference

If a stable source of  $V_{DD}$  is provided, the reference measurement point can be internally selected. In this case, the reference reading can be taken by setting the  $V_{REF}$  bit and clearing the MUX1:4 bits in the AMUX register. This connects the channel selection bus to the  $V_{DD}$  pin. To stay within the  $V_{MAX}$  range, the DHOLD bit should be used to select the 1/2 divided input.

### 8.6.1.2 External Absolute Reference

If a stable external source is provided, the reference measurement point can be any one of the channel selected pins from PB1–PB4. In this case the reference reading can be taken by setting the MUX bit in the AMUX which connects channel selection bus to the pin connected to the external reference source. If the external reference is greater than  $V_{DD} - 1.5$  volts, then the DHOLD bit should be used to select the 1/2 divided input.

**Table 8-6. Absolute Voltage Reading Errors**

Error Source	Accuracy Improvements Possible	
	In Hardware	In Software
Change in reference voltage	Provide closer tolerance reference	Calibration and storage of reference source over temperature and supply voltage
Change in magnitude of ramp current source	Not adjustable	Compare unknown with recent measurement from reference
Non-linearity of ramp current source vs. voltage	Not adjustable	Calibration and storage of voltages at 1/4, 1/2, 3/4, and FS
Frequency shift in internal low-power oscillator	Use external oscillator with crystal	Compare unknown with recent measurement from reference
Sampling capacitor leakage	Use faster conversion times	Compare unknown with recent measurement from reference
Internal voltage divider ratio	Not adjustable	Compare unknown with recent measurement from reference OR avoid use of divided input
Input offset voltage of comparator 2	Not adjustable	Sum two readings on reference or unknown using INV and $\overline{INV}$ control bit and divide by 2 (average of both)
Noise internal to MCU	Close decoupling at $V_{DD}$ and $V_{SS}$ pins and reduce supply source impedence	Average multiple readings on both the reference and the unknown voltage

## 8.6.2 Ratiometric Voltage Readings

The ratiometric value of a voltage measurement can be calculated in software by first taking a reference reading from a reference source and then comparing subsequent unknown voltages to that reading as a percentage of the reference value. The accuracy of ratiometric readings will depend on the variety of sources, but will generally be better than for absolute readings. Many of these error sources can be taken into account using the features of the analog subsystem and appropriate software as described in [Table 8-7](#). As with absolute measurements, most of the errors can be reduced by frequent comparisons to the reference voltage, use of the inverted comparator inputs, and averaging of multiple samples.

**Table 8-7. Ratiometric Voltage Reading Errors**

Error Source	Accuracy Improvements Possible	
	In Hardware	In Software
Change in reference voltage	Not required for ratiometric	Compare unknown with recent measurement from reference
Change in magnitude of ramp current source	Not adjustable	Compare unknown with recent measurement from reference
Non-linearity of ramp current source vs. voltage	Not adjustable	Calibration and storage of voltages at 1/4, 1/2, 3/4, and FS
Frequency shift in internal low-power oscillator	Not required for ratiometric	Compare unknown with recent measurement from reference
Sampling capacitor leakage	Use faster conversion times	Compare unknown with recent measurement from reference
Internal voltage divider ratio	Not adjustable	Compare unknown with recent measurement from reference
Input offset voltage of comparator 2	Not adjustable	Sum two readings on reference or unknown using INV and $\overline{INV}$ control bit and divide by 2 (average of both)
Noise internal to MCU	Close decoupling at $V_{DD}$ and $V_{SS}$ pins and reduce supply source impedance	Average multiple readings on both the reference and the unknown voltage

### 8.6.2.1 Internal Ratiometric Reference

If readings are to be ratiometric to  $V_{DD}$ , the reference measurement point can be internally selected. In this case the reference reading can be taken by setting the  $V_{REF}$  bit and clearing the MUX1:4 bits in the AMUX register which connects the channel selection bus to the  $V_{DD}$  pin. In order to stay within the  $V_{MAX}$  range, the DHOLD bit should be used to select the 1/2 divided input.

### 8.6.2.2 External Ratiometric Reference

If readings are to be ratiometric to some external source, the reference measurement point can be connected to any one of the channel selected pins from PB1–PB4. In this case, the reference reading can be taken by setting the MUX bit in the AMUX which connects channel selection bus to the pin connected to the external reference source. If the external reference is greater than  $V_{DD} - 1.5$  volts, then the DHOLD bit should be used to select the 1/2 divided input.

## 8.7 Voltage Comparator Features

The two internal comparators can be used as simple voltage comparators if set up as described in [Table 8-8](#). Both comparators can be active in the wait mode and can directly restart the part by means of the analog interrupt. Both comparators can also be active in the stop mode, but cannot directly restart the part. However, the comparators can directly drive PB4 which can then be connected externally to activate either a port interrupt on the PA0:3 pins or the  $\overline{IRQ}/V_{PP}$  pin.

**Table 8-8. Voltage Comparator Setup Conditions**

Comparator	Current Source Enable	Discharge Device Disable	Port B Pin as Inputs	Port B Pin Pulldowns Disabled	Prog. Timer Input Capture Source
1	Not affected	Not affected	DDRB2 = 0 DDRB3 = 0	PDIB2 = 1 PDIB3 = 1	Not affected
2	ISEN = 0	ISEN = 0	DDRB0 = 0 DDRB1 = 0	PDIB0 = 1 PDIB1 = 1	ICEN = 0 IEDG = 1

### 8.7.1 Voltage Comparator 1

Voltage comparator 1 is always connected to two of the port B I/O pins. These pins should be configured as inputs and have their software programmable pulldowns disabled. Also, the negative input of voltage comparator 1 is connected to the PB3/AN3/TCAP and shared with the input capture function of the 16-bit programmable timer. Therefore, the timer input capture interrupt should be disabled so that changes in the voltage on the PB3/AN3/TCAP pin do not cause unwanted input capture interrupts.

The output of comparator 1 can be connected to the port logic driving the PB4/AN4/TCMP/CMP1 pin such that the output of the comparator is ORed with the PB4 data bit and the OLVL bit from the 16-bit timer. This capability requires that the OPT bit is set in the COPR at location \$1FF0 as in [Figure 8-12](#), and the COE1 bit is set in the ASR at location \$001E.

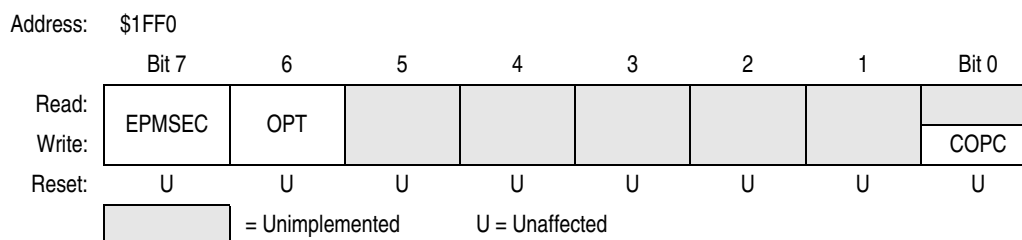

**Figure 8-12. COP and Security Register (COPR)**

#### OPT — Optional Features Bit

The OPT bit enables two additional features: direct drive by comparator 1 output to PB4 and voltage offset capability to sample capacitor in analog subsystem.

- 1 = Optional features enabled
- 0 = Optional features disabled

## 8.7.2 Voltage Comparator 2

Voltage comparator 2 can be used as a simple comparator if its charge current source and discharge device are disabled by clearing the ISEN bit in the ACR. If the ISEN bit is set, the internal ramp discharge device connected to PB0/AN0 may become active and try to pull down any voltage source that may be connected to that pin. Also, since voltage comparator 2 is always connected to two of the port B I/O pins, these pins should be configured as inputs and have their software programmable pulldowns disabled.

## 8.8 Current Source Features

The internal current source connected to the PB0/AN0 pin supplies about 100  $\mu\text{A}$  of current when the discharge device is disabled and the current source is active. Therefore, this current source can be used in an application if the ISEN enable bit is set to power up the current source and by setting the A/D conversion method to manual mode 0 (ATD1 and ATD2 cleared) and the charge current enabled (CHG set).

## 8.9 Internal Temperature Sensing Diode Features

An internal diode is forward biased to  $V_{SS}$  and will have its voltage change,  $V_D$ , for each degree centigrade rise in the temperature of the device. This temperature sensing diode is powered up from a current source only during the time that the diode is selected. When on, this current source typically adds about 30  $\mu\text{A}$  to the  $I_{DD}$  current.

The temperature sensing diode can be selected by setting both the HOLD and DHOLD bits in the AMUX register (see [8.2 Analog Multiplex Register](#)).

## 8.10 Sample and Hold

When using the internal sample capacitor to capture a voltage for later conversion, the HOLD or DHOLD bit must be cleared first before changing any channel selection. If both the HOLD (or DHOLD) bit and the channel selection are changed on the same write cycle, the sample may be corrupted during the switching transitions.

### NOTE

*The sample capacitor can be affected by excessive noise created with respect to the device's  $V_{SS}$  pin such that it may appear to leak down or charge up depending on the voltage level stored on the sample capacitor. It is recommended to avoid switching large currents through the port pins while a voltage is to remain stored on the sample capacitor.*

The additional option of adding an offset voltage to the bottom of the sample capacitor allows unknown voltages near  $V_{SS}$  to be sampled and then shifted up past the comparator offset and the device offset caused by a single  $V_{SS}$  return pin. This offset also provides a means to measure the internal  $V_{SS}$  level regardless of the comparator offset to determine  $N_{OFF}$  as described in [8.6 Voltage Measurement Methods](#). In either case the OPT bit must be set in the COPR located at \$1FF0 as in [Figure 8-12](#) and the VOFF bit must be set in the ASR. It is not necessary to switch the VOFF bit during conversions, since the offset is controlled by the HOLD and DHOLD bits when the VOFF is active. Refer to [8.2 Analog Multiplex Register](#) for more details on the design and decoding of the sample and hold circuit.

## 8.11 Port B Interaction with Analog Inputs

The analog subsystem is connected directly to the port B I/O pins without any intervening gates. It is, therefore, possible to measure the voltages on port B pins set as inputs or to have the analog voltage measurements corrupted by port B pins set as outputs.

## 8.12 Port B Pins as Inputs

All the port B pins will power up as inputs or return to inputs after a reset of the device since the bits in the port B data direction register will be reset.

If any port B pins are to be used for analog voltage measurements, they should be left as inputs. In this case, not only can the voltage on the pin be measured, but the logic state of the port B pins can be read from location \$0002.

## 8.13 Port B Pulldowns

All the port B pins have internal software programmable pulldown devices available dependent on the state of the SWPDI bit in the mask option register (MOR).

If the pulldowns are enabled, they will create an approximate 100  $\mu$ A load to any analog source connected to the pin. In some cases, the analog source may be able to supply this current without causing any error due to the analog source output impedance. Since this may not always be true, it is therefore best to disable port B pulldowns on those pins used for analog input sources.

## 8.14 Noise Sensitivity

In addition to the normal effects of electrical noise on the analog input signal there can also be other noise-related effects caused by the digital-to-analog interface. Since there is only one  $V_{SS}$  return for both the digital and the analog subsystems on the device, currents in the digital section may affect the analog ground reference within the device. This can add voltage offsets to measured inputs or cause channel-to-channel crosstalk.

To reduce the impact of these effects, there should be no switching of heavy I/O currents to or from the device while there is a critical analog conversion or voltage comparison in process. Limiting switched I/O currents to 2–4 mA during these times is recommended.

A noise reduction benefit can be gained with 0.1- $\mu$ F bypass capacitors from each analog input (PB4:1) to the  $V_{SS}$  pin. Also, try to keep all the digital power supply or load currents from passing through any conductors which are the return paths for an analog signal.

# Chapter 9

## Simple Synchronous Serial Interface

### 9.1 Introduction

The simple synchronous serial I/O port (SIOP) subsystem is designed to provide efficient serial communications with peripheral devices or other MCUs. SIOP is implemented as a 3-wire master/slave system with serial clock (SCK), serial data input (SDI), and serial data output (SDO). A block diagram of the SIOP is shown in [Figure 9-1](#).

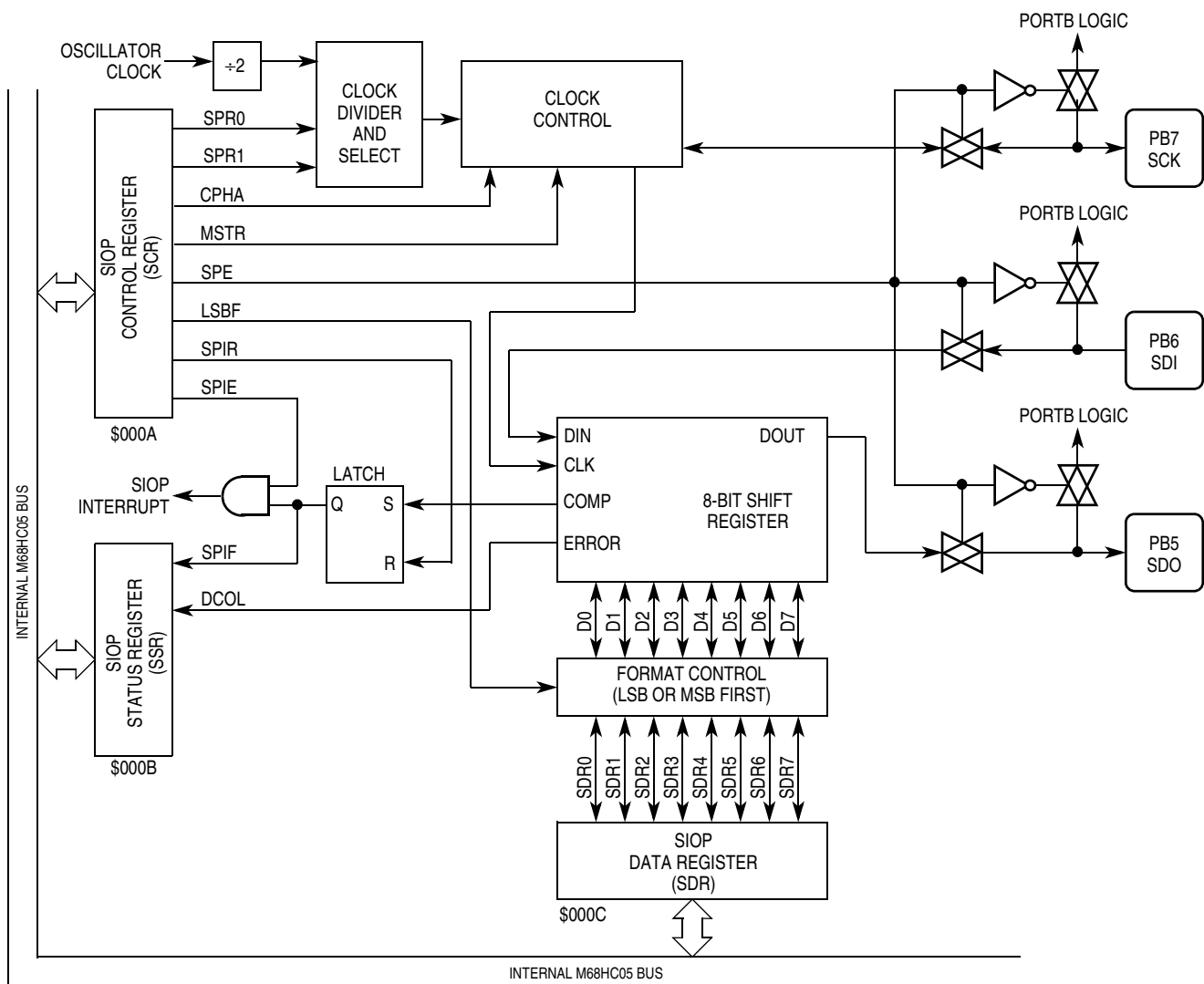

**Figure 9-1. SIOP Block Diagram**

## Simple Synchronous Serial Interface

The SIOP subsystem shares its input/output pins with port B. When the SIOP is enabled (SPE bit set in the SCR), the port B data direction and data registers are bypassed by the SIOP. The port B data direction and data registers will remain accessible and can be altered by the application software, but these actions will not affect the SIOP transmitted or received data.

## 9.2 SIOP Signal Format

The SIOP subsystem can be software configured for master or slave operation. No external mode selection inputs are available (for instance, no slave select pin).

### 9.2.1 Serial Clock (SCK)

The state of the SCK output remains a fixed logic level during idle periods between data transfers. The edges of SCK indicate the beginning of each output data transfer and latch any incoming data received. The first bit of transmitted data is output from the SDO pin on the first falling edge of SCK. The first bit of received data is accepted at the SDI pin on the first rising edge of SCK after the first falling edge. The transfer is terminated upon the eighth rising edge of SCK.

The idle state of the SCK is determined by the state of the CPHA bit in the SCR. When the CPHA is clear, SCK will remain idle at a logic 1 as shown in Figure 9-2. When the CPHA is set, SCK will remain idle at a logic 0 as shown in Figure 9-3. In both cases, the SDO changes data on the falling edge of the SCK, and the SDI latches data in on the rising edge of SCK.

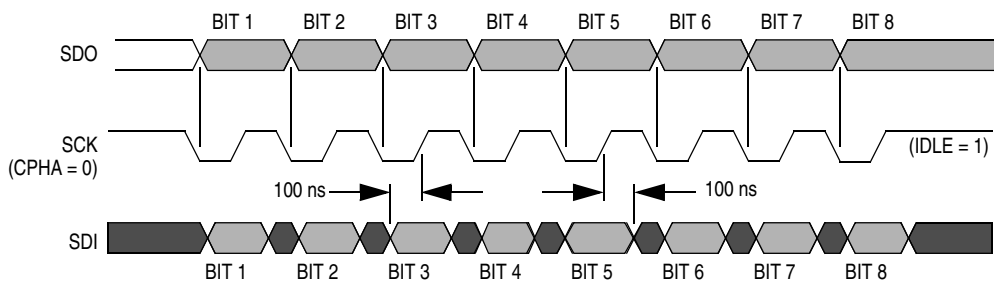

**Figure 9-2. SIOP Timing Diagram (CPHA = 0)**

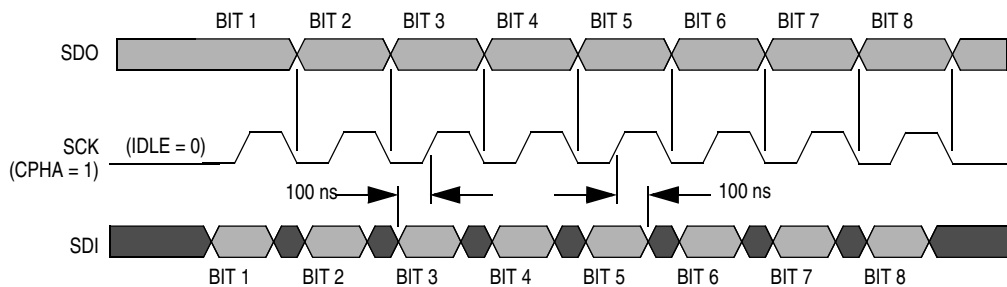

**Figure 9-3. SIOP Timing Diagram (CPHA = 1)**

The only difference in the master and slave modes of operation is the sourcing of the SCK. In master mode, SCK is driven from an internal source within the MCU. In slave mode, SCK is driven from a source external to the MCU. The SCK frequency is based on one of four divisions of the oscillator clock that is selected by the SPR0 and SPR1 bits in the SCR.

### 9.2.2 Serial Data Input (SDI)

The SDI pin becomes an input as soon as the SIOP subsystem is enabled. New data is presented to the SDI pin on the falling edge of SCK. Valid data must be present at least 100 nanoseconds before the rising edge of SCK and remain valid for 100 nanoseconds after the rising edge of SCK. See [Figure 9-3](#).

### 9.2.3 Serial Data Output (SDO)

The SDO pin becomes an output as soon as the SIOP subsystem is enabled. The state of the PB5/SDO pin reflects the value of the first bit received on the previous transmission. Prior to enabling the SIOP, the PB5/SDO can be initialized to determine the beginning state. While SIOP is enabled, the port B logic cannot be used as a standard output since that pin is connected to the last stage of the SIOP serial shift register. A control bit (LSBF) is included in the SCR to allow the data to be transmitted in either the MSB first format or the LSB first format.

The first data bit will be shifted out to the SDO pin on the first falling edge of the SCK. The remaining data bits will be shifted out to the SDI pin on subsequent falling edges of SCK. The SDO pin will present valid data at least 100 nanoseconds before the rising edge of the SCK and remain valid for 100 nanoseconds after the rising edge of SCK. See [Figure 9-3](#).

## 9.3 SIOP Registers

The SIOP is programmed and controlled by the SIOP control register (SCR) located at address \$000A, the SIOP status register (SSR) located at address \$000B, and the SIOP data register (SDR) located at address \$000C.

### 9.3.1 SIOP Control Register (SCR)

The SIOP control register (SCR) is located at address \$000A and contains seven control bits and a write-only reset of the interrupt flag. [Figure 9-4](#) shows the position of each bit in the register and indicates the value of each bit after reset.

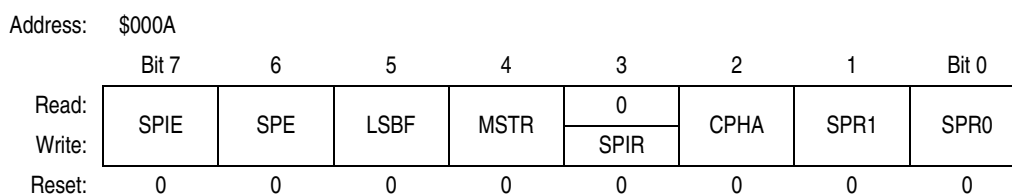

**Figure 9-4. SIOP Control Register (SCR)**

#### SPIE — Serial Peripheral Interrupt Enable Bit

The SPIE bit enables the SIOP to generate an interrupt whenever the SPIF flag bit in the SSR is set. Clearing the SPIE bit will not affect the state of the SPIF flag bit and will not terminate a serial interrupt once the interrupt sequence has started. Reset clears the SPIE bit.

- 1 = Serial interrupt enabled
- 0 = Serial interrupt disabled

**NOTE**

*If the SPIE bit is cleared just after the serial interrupt sequence has started (for instance, the CPU status is being stacked), then the CPU will be unable*

*to determine the source of the interrupt and will vector to the reset vector as a default.*

### **SPE — Serial Peripheral Enable Bit**

The SPE bit switches the port B interface such that SDO/PB5 is the serial data output, SDI/PB6 is the serial data input, and SCK/PB7 is a serial clock input in the slave mode or a serial clock output in the master mode. The port B DDR and data registers can be manipulated as usual, but these actions will not affect the transmitted or received data. The SPE bit is readable and writable at any time, but clearing the SPE bit while a transmission is in progress will 1) abort the transmission, 2) reset the serial bit counter, and 3) convert port B to a general-purpose I/O port. Reset clears the SPE bit.

- 1 = Serial peripheral enabled (port B I/O disabled)
- 0 = Serial peripheral disabled (port B I/O enabled)

### **LSBF — Least Significant Bit First Bit**

The LSBF bit controls the format of the transmitted and received data to be transferred LSB or MSB first. Reset clears this bit.

- 1 = LSB transferred first
- 0 = MSB transferred first

### **MSTR — Master Mode Select Bit**

The MSTR bit configures the serial I/O port for master mode. A transfer is initiated by writing to the SDR. Also, the SCK pin becomes an output providing a synchronous data clock dependent upon the divider of the oscillator frequency selected by the SPR0:1 bits. When the device is in master mode, the SDO and SDI pins do not change function. These pins behave exactly the same in both the master and slave modes. The MSTR bit is readable and writable at any time regardless of the state of the SPE bit. Clearing the MSTR bit will abort any transfers that may have been in progress. Reset clears the MSTR bit, placing the SIOP subsystem in slave mode.

- 1 = SIOP set up as master, SCK is an output
- 0 = SIOP set up as slave, SCK is an input

### **SPIR — Serial Peripheral Interrupt Reset Bit**

The SPIR bit is a write-only control to reset the SPIF flag bit in the SSR. Reading the SPIR bit will return a logic 0.

- 1 = Reset the SPIF flag bit
- 0 = No effect

### **CPHA — Clock Phase Bit**

The CPHA bit controls the clock timing and phase in the SIOP. Data is changed on the falling edge of SCK and data is captured (read) on the rising edge of SCK. This bit is cleared by reset.

- 1 = SCK is idle low
- 0 = SCK is idle high

### **SPR0:1 — Serial Peripheral Clock Rate Select Bits**

The SPR0 and SPR1 bits select one of four clock rates given in [Table 9-1](#) to be supplied on the PB7/SCK pin when the device is configured with the SIOP as a master (MSTR = 1). The fastest rate is when both SPR0 and SPR1 are set. Both the SPR0 and SPR1 bits are cleared by reset, which places the SIOP clock selection at the slowest rate.

**Table 9-1. SIOPI Clock Rate Selection**

SPR1	SPR0	SIOPI Clock Rate Oscillator Frequency Divided by:
0	0	64
0	1	32
1	0	16
1	1	8

### 9.3.2 SIOPI Status Register

The SIOPI status register (SSR) is located at address \$000B and contains two read-only bits. Figure 9-5 shows the position of each bit in the register and indicates the value of each bit after reset.

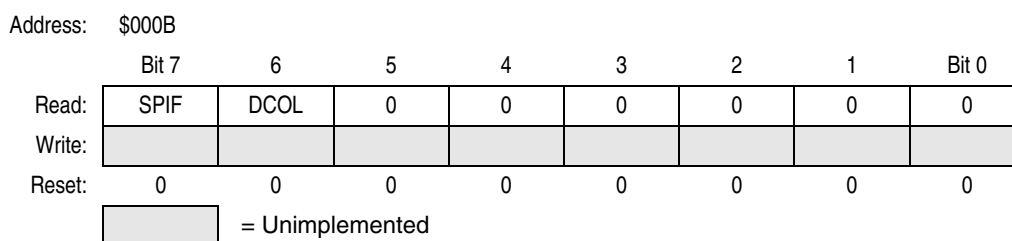

**Figure 9-5. SIOPI Status Register (SSR)**

#### SPIF — Serial Port Interrupt Flag

The SPIF is a read-only status bit that is set on the last rising edge of SCK and indicates that a data transfer has been completed. It has no effect on any future data transfers and can be ignored. The SPIF bit can be cleared by reading the SSR followed by a read or write of the SDR or by writing a logic 1 to the SPIR bit in the SCR. If the SPIF is cleared before the last rising edge of SCK it will be set again on the last rising edge of SCK. Reset clears the SPIF bit.

- 1 = Serial transfer complete, serial interrupt if the SPIE bit in SCR is set
- 0 = Serial transfer in progress or serial interface idle

#### DCOL — Data Collision Bit

The DCOL is a read-only status bit which indicates that an illegal access of the SDR has occurred. The DCOL bit will be set when reading or writing the SDR after the first falling edge of SCK and before SPIF is set. Reading or writing the SDR during this time will result in invalid data being transmitted or received. The DCOL bit is cleared by reading the SSR (when the SPIF bit is set) followed by a read or write of the SDR. If the last part of the clearing sequence is done after another transfer has started, the DCOL bit will be set again. Reset clears the DCOL bit.

- 1 = Illegal access of the SDR occurred
- 0 = No illegal access of the SDR detected

### 9.3.3 SIOP Data Register

The SIOP data register (SDR) is located at address \$000C and serves as both the transmit and receive data register. Writing to this register will initiate a message transmission if the node is in master mode. The SIOP subsystem is not double buffered and any write to this register will destroy the previous contents. The SDR can be read at any time. However, if a transfer is in progress the results may be ambiguous. Writing to the SDR while a transfer is in progress can cause invalid data to be transmitted and/or received. [Figure 9-6](#) shows the position of each bit in the register. This register is not affected by reset.

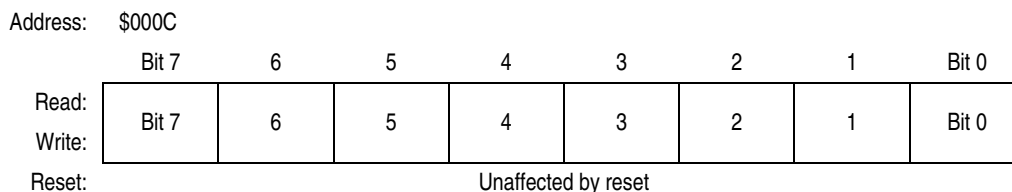
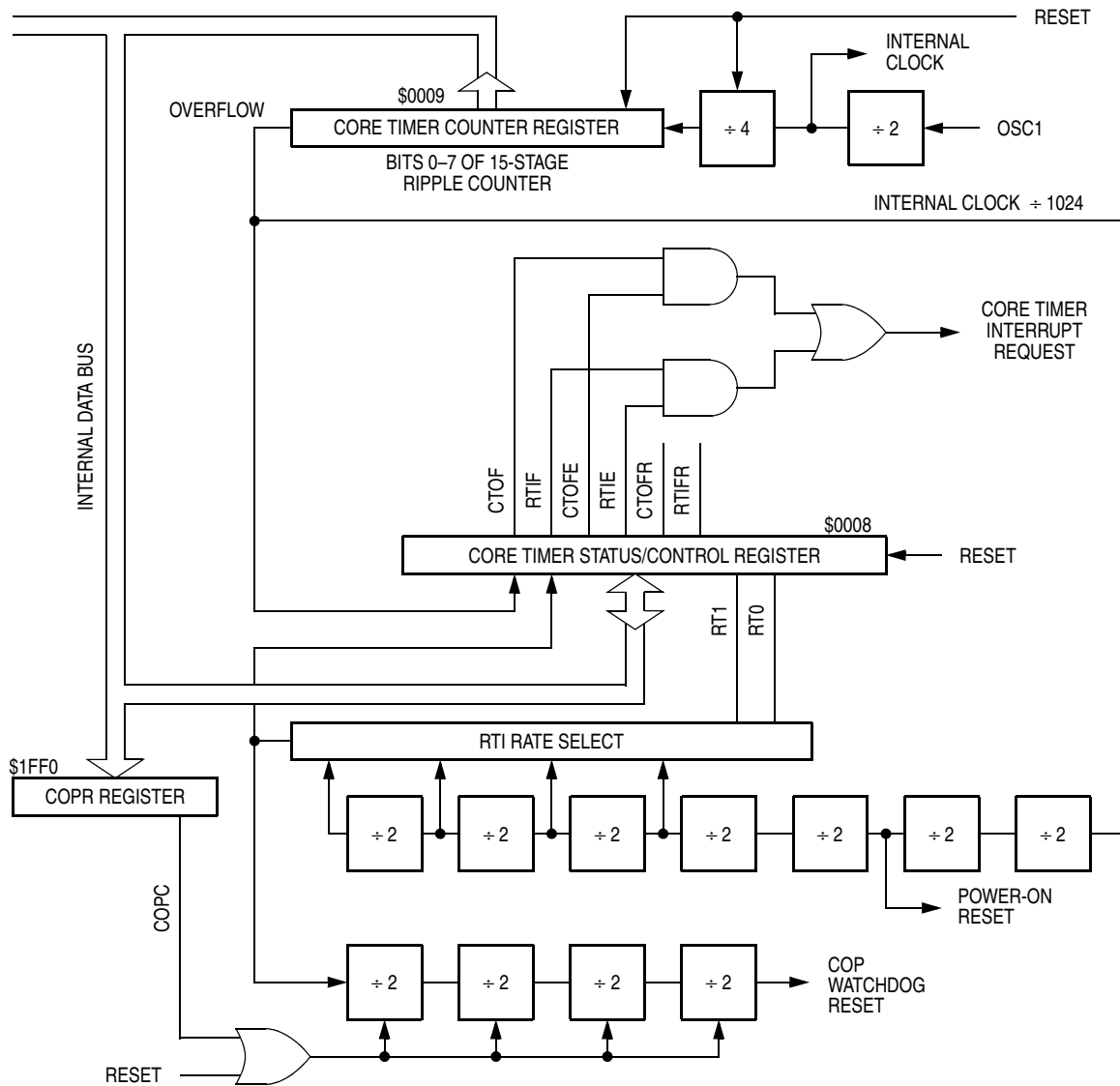

**Figure 9-6. SIOP Data Register (SDR)**

# Chapter 10 Core Timer

## 10.1 Introduction

This section describes the operation of the core timer and the computer operating properly (COP) watchdog as shown by the block diagram in [Figure 10-1](#).



**Figure 10-1. Core Timer Block Diagram**

## 10.2 Core Timer Status and Control Register

The read/write core timer status and control register (CTSCR) contains the interrupt flag bits, interrupt enable bits, interrupt flag bit resets, and the rate selects for the real-time interrupt as shown in [Figure 10-2](#).

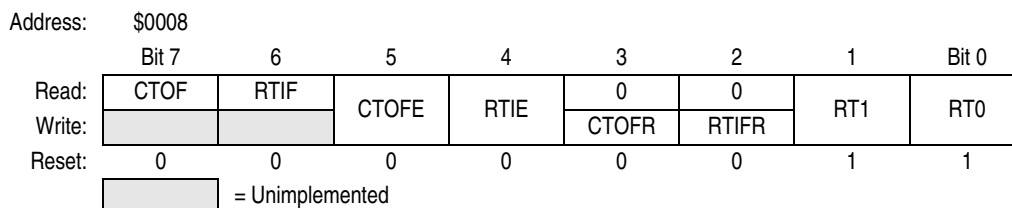

**Figure 10-2. Core Timer Status and Control Register (CTSCR)**

### CTOF — Core Timer Overflow Flag

This read-only flag becomes set when the first eight stages of the core timer counter roll over from \$FF to \$00. The CTOF flag bit generates a timer overflow interrupt request if CTOFE is also set. The CTOF flag bit is cleared by writing a logic 1 to the CTOFR bit. Writing to CTOF has no effect. Reset clears CTOF.

- 1 = Overflow in core timer has occurred.
- 0 = No overflow of core timer since CTOF last cleared

### RTIF — Real-Time Interrupt Flag

This read-only flag becomes set when the selected real-time interrupt (RTI) output becomes active. RTIF generates a real-time interrupt request if RTIE is also set. The RTIF enable bit is cleared by writing a logic 1 to the RTIFR bit. Writing to RTIF has no effect. Reset clears RTIF.

- 1 = Overflow in real-time counter has occurred.
- 0 = No overflow of real-time counter since RTIF last cleared

### CTOFE — Core Timer Overflow Interrupt Enable Bit

This read/write bit enables core timer overflow interrupts. Reset clears CTOFE.

- 1 = Core timer overflow interrupts enabled
- 0 = Core timer overflow interrupts disabled

### RTIE — Real-Time Interrupt Enable Bit

This read/write bit enables real-time interrupts. Reset clears RTIE.

- 1 = Real-time interrupts enabled
- 0 = Real-time interrupts disabled

### CTOFR — Core Timer Overflow Flag Reset Bit

Writing a logic 1 to this write-only bit clears the CTOF bit. CTOFR always reads as a logic 0. Reset does not affect CTOFR.

- 1 = Clear CTOF flag bit
- 0 = No effect on CTOF flag bit

### RTIFR — Real-Time Interrupt Flag Reset Bit

Writing a logic 1 to this write-only bit clears the RTIF bit. RTIFR always reads as a logic 0. Reset does not affect RTIFR.

- 1 = Clear RTIF flag bit
- 0 = No effect on RTIF flag bit

### RT1 and RT0 — Real-Time Interrupt Select Bits 1 and 0

These read/write bits select one of four real-time interrupt rates, as shown in [Table 10-1](#). Because the selected RTI output drives the COP watchdog, changing the real-time interrupt rate also changes the

counting rate of the COP watchdog. Reset sets RT1 and RT0, selecting the longest COP timeout period and longest real-time interrupt period.

**NOTE**

*Changing RT1 and RT0 when a COP timeout is imminent or uncertain may cause a real-time interrupt request to be missed or an additional real-time interrupt request to be generated. Clear the COP timer just before changing RT1 and RT0.*

**Table 10-1. Core Timer Interrupt Rates and COP Timeout Selection**

Timer Overflow Interrupt Period TOF = 1/(f <sub>OSC</sub> ÷ 2 <sup>11</sup> ) (Microseconds)			RT1	RT0	RTI Rate = f <sub>OSC</sub> divided by:	Real-Time Interrupt Period (RTI) (Milliseconds)			COP Timeout Period COP = 7-to-8 RTI Periods (Milliseconds)					
@ f <sub>OSC</sub> (MHz)						@ f <sub>OSC</sub> (MHz)			@ f <sub>OSC</sub> (MHz)					
4.2 MHz	2.0 MHz	1.0 MHz				4.2 MHz	2.0 MHz	1.0 MHz	4.2 MHz		2.0 MHz		1.0 MHz	
			Min	Max	Min	Max	Min	Max	Min	Max	Min	Max		
488	1024	2048	0	0	2 <sup>15</sup>	7.80	16.4	32.8	54.6	62.4	115	131	229	262
			0	1	2 <sup>16</sup>	15.6	32.8	65.5	109	125	229	262	459	524
			1	0	2 <sup>17</sup>	31.2	65.5	131	218	250	459	524	918	1049
			1	1	2 <sup>18</sup>	62.4	131	262	437	499	918	1049	1835	2097

### 10.3 Core Timer Counter Register

A 15-stage ripple counter driven by a divide-by-eight prescaler is the basis of the core timer. The value of the first eight stages is readable at any time from the read-only timer counter register as shown in [Figure 10-3](#).

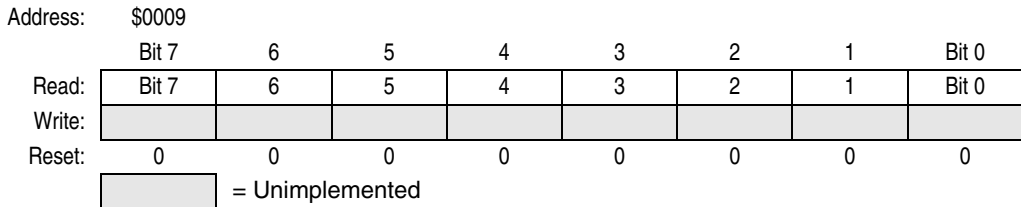

**Figure 10-3. Core Timer Counter Register (CTCR)**

Power-on clears the entire counter chain and begins clocking the counter. After the startup delay (16 or 4064 internal bus cycles depending on the DELAY bit in the mask option register (MOR)), the power-on reset circuit is released, clearing the counter again and allowing the MCU to come out of reset.

Each count of the timer counter register takes eight oscillator cycles or four cycles of the internal bus. A timer overflow function at the eighth counter stage allows a timer interrupt every 2048 oscillator clock cycles or every 1024 internal bus cycles.

### 10.4 COP Watchdog

Four counter stages at the end of the core timer make up the computer operating properly (COP) watchdog which can be enabled by the COPEN bit in the MOR. The COP watchdog is a software error detection system that automatically times out and resets the MCU if the COP watchdog is not cleared

periodically by a program sequence. Writing a logic 0 to COPC bit in the COPR register clears the COP watchdog and prevents a COP reset.

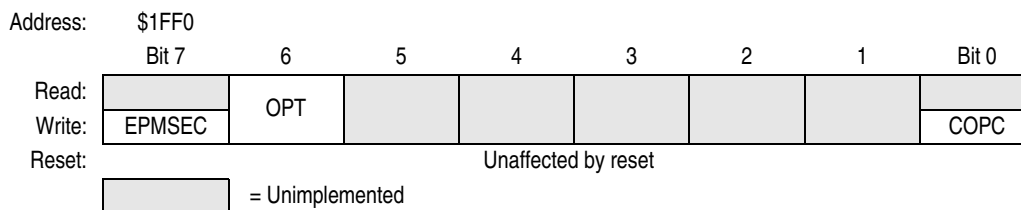

**Figure 10-4. COP and Security Register (COPR)**

**EPMSEC — EPROM Security<sup>(1)</sup> Bit**

The EPMSEC bit is a write-only security bit to protect the contents of the user EPROM code stored in locations \$0700–\$1FFF.

**OPT — Optional Features Bit**

The OPT bit enables two additional features: direct drive by comparator outputs to port A and voltage offset capability to sample capacitor in analog subsystem.

- 1 = Optional features enabled
- 0 = Optional features disabled

**COPC — COP Clear Bit**

This write-only bit resets the COP watchdog. The COP watchdog is active in the run, wait, and halt modes of operation if the COP is enabled by setting the COPEN bit in the MOR. The STOP instruction disables the COP watchdog by clearing the counter and turning off its clock source.

In applications that depend on the COP watchdog, the STOP instruction can be disabled by setting the SWAIT bit in the MOR. In applications that have wait cycles longer than the COP timeout period, the COP watchdog can be disabled by clearing the COPEN bit. [Table 10-2](#) summarizes recommended conditions for enabling and disabling the COP watchdog.

**NOTE**

*If the voltage on the  $\overline{TRQ}/V_{PP}$  pin exceeds  $1.5 \times V_{DD}$ , the COP watchdog turns off and remains off until the  $\overline{TRQ}/V_{PP}$  pin voltage falls below  $1.5 \times V_{DD}$ .*

**Table 10-2. COP Watchdog Recommendations**

Voltage on $\overline{TRQ}/V_{PP}$ Pin	SWAIT (in MOR) <sup>(1)</sup>	Wait/Halt Time	Recommended COP Watchdog Condition
Less than $1.5 \times V_{DD}$	1	Less than COP timeout period	Enabled <sup>(2)</sup>
Less than $1.5 \times V_{DD}$	1	Greater than COP timeout period	Disabled
Less than $1.5 \times V_{DD}$	0	X <sup>(3)</sup>	Disabled
More than $1.5 \times V_{DD}$	X	X <sup>(3)</sup>	Disabled

1. The SWAIT bit in the MOR converts STOP instructions to HALT instructions.
2. Reset the COP watchdog immediately before executing the WAIT/HALT instruction.
3. Don't care

1. No security feature is absolutely secure. However, Freescale's strategy is to make reading or copying the EPROM/OTPROM difficult for unauthorized users.

# Chapter 11

## Programmable Timer

### 11.1 Introduction

The MC68HC705JJ7/MC68HC705JP7 MCU contains a 16-bit programmable timer with an input capture function and an output compare function as shown by the block diagram in [Figure 11-1](#).

The basis of the capture/compare timer is a 16-bit free-running counter which increases in count with every four internal bus clock cycles. The counter is the timing reference for the input capture and output compare functions. The input capture and output compare functions provide a means to latch the times at which external events occur, to measure input waveforms, and to generate output waveforms and timing delays. Software can read the value in the 16-bit free-running counter at any time without affecting the counter sequence.

The input/output (I/O) registers for the input capture and output compare functions are pairs of 8-bit registers, because of the 16-bit timer architecture used. Each register pair contains the high and low bytes of that function. Generally, accessing the low byte of a specific timer function allows full control of that function; however, an access of the high byte inhibits that specific timer function until the low byte is also accessed.

Because the counter is 16 bits long and preceded by a fixed divide-by-four prescaler, the counter rolls over every 262,144 internal clock cycles (every 524,288 oscillator clock cycles). Timer resolution with a 4-MHz crystal oscillator is 2 microseconds/count.

The interrupt capability, the input capture edge, and the output compare state are controlled by the timer control register (TCR) located at \$0012, and the status of the interrupt flags can be read from the timer status register (TSR) located at \$0013.

# Programmable Timer

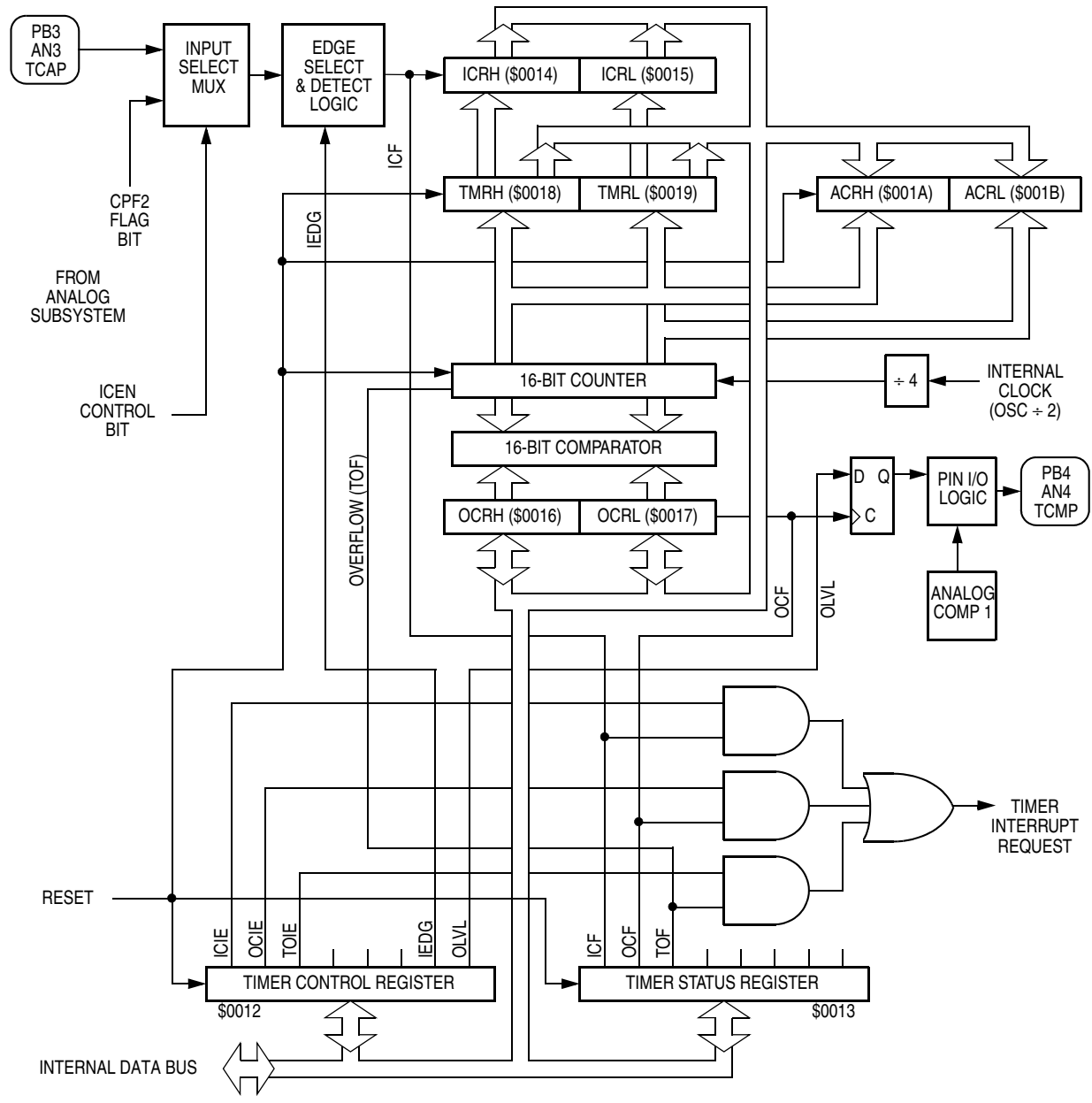

**Figure 11-1. Programmable Timer Overall Block Diagram**

## 11.2 Timer Registers

The functional block diagram of the 16-bit free-running timer counter and timer registers is shown in [Figure 11-2](#). The timer registers include a transparent buffer latch on the LSB of the 16-bit timer counter.

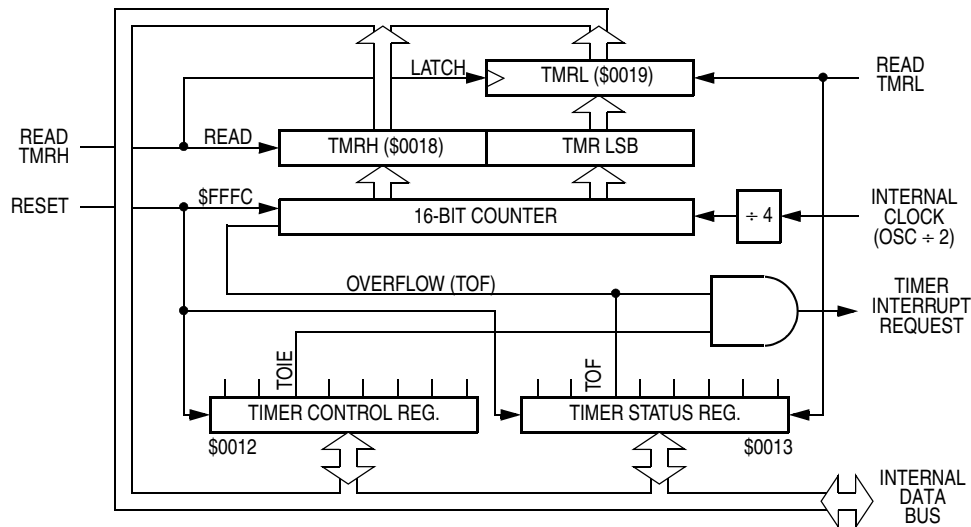

**Figure 11-2. Programmable Timer Block Diagram**

The timer registers (TMRH and TMRL) shown in [Figure 11-3](#) are read-only locations which contain the current high and low bytes of the 16-bit free-running counter. Writing to the timer registers has no effect. Reset of the device presets the timer counter to \$FFFC.

The TMRL latch is a transparent read of the LSB until a read of the TMRH takes place. A read of the TMRH latches the LSB into the TMRL location until the TMRL is again read. The latched value remains fixed even if multiple reads of the TMRH take place before the next read of the TMRL. Therefore, when reading the MSB of the timer at TMRH, the LSB of the timer at TMRL must also be read to complete the read sequence.

During power-on reset (POR), the counter is initialized to \$FFFC and begins counting after the oscillator startup delay. Because the counter is 16 bits and preceded by a fixed prescaler, the value in the counter repeats every 262,144 internal bus clock cycles (524,288 oscillator cycles).

Address:	\$0018							
	Bit 7	6	5	4	3	2	1	Bit 0
Read:	Bit 15	14	13	12	11	10	9	Bit 8
Write:								
Reset:	1	1	1	1	1	1	1	1

Address:	\$0018							
	Bit 7	6	5	4	3	2	1	Bit 0
Read:	Bit 7	6	5	4	3	2	1	Bit 0
Write:								
Reset:	1	1	1	1	1	1	0	0

= Unimplemented

**Figure 11-3. Programmable Timer Registers (TMRH and TMRL)**

## Programmable Timer

When the free-running counter rolls over from \$FFFF to \$0000, the timer overflow flag bit (TOF) is set in the TSR. When the TOF is set, it can generate an interrupt if the timer overflow interrupt enable bit (TOIE) is also set in the TCR. The TOF flag bit can only be reset by reading the TMRL after reading the TSR.

Other than clearing any possible TOF flags, reading the TMRH and TMRL in any order or any number of times does not have any effect on the 16-bit free-running counter.

### NOTE

*To prevent interrupts from occurring between readings of the TMRH and TMRL, set the I bit in the condition code register (CCR) before reading TMRH and clear the I bit after reading TMRL.*

## 11.3 Alternate Counter Registers

The functional block diagram of the 16-bit free-running timer counter and alternate counter registers is shown in Figure 11-4. The alternate counter registers behave the same as the timer registers, except that any reads of the alternate counter will not have any effect on the TOF flag bit and timer interrupts. The alternate counter registers include a transparent buffer latch on the LSB of the 16-bit timer counter.

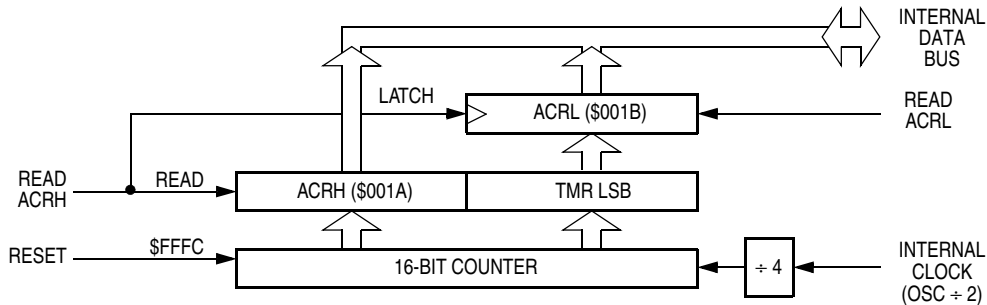

**Figure 11-4. Alternate Counter Block Diagram**

The alternate counter registers (ACRH and ACRL) shown in Figure 11-5 are read-only locations which contain the current high and low bytes of the 16-bit free-running counter. Writing to the alternate counter registers has no effect. Reset of the device presets the timer counter to \$FFFC.

Address:	\$001A							
	Bit 7	6	5	4	3	2	1	Bit 0
Read:	Bit 15	14	13	12	11	10	9	Bit 8
Write:								
Reset:	1	1	1	1	1	1	1	1
Address:	\$001B							
	Bit 7	6	5	4	3	2	1	Bit 0
Read:	Bit 7	6	5	4	3	2	1	Bit 0
Write:								
Reset:	1	1	1	1	1	1	0	0
	= Unimplemented							

**Figure 11-5. Alternate Counter Registers (ACRH and ACRL)**

The ACRL latch is a transparent read of the LSB until a read of the ACRH takes place. A read of the ACRH latches the LSB into the ACRL location until the ACRL is again read. The latched value remains fixed even

if multiple reads of the ACRH take place before the next read of the ACRL. Therefore, when reading the MSB of the timer at ACRH, the LSB of the timer at ACRL must also be read to complete the read sequence.

During power-on reset (POR), the counter is initialized to \$FFFC and begins counting after the oscillator startup delay. Because the counter is 16 bits and preceded by a fixed prescaler, the value in the counter repeats every 262,144 internal bus clock cycles (524,288 oscillator cycles).

Reading the ACRH and ACRL in any order or any number of times does not have any effect on the 16-bit free-running counter or the TOF flag bit.

**NOTE**

*To prevent interrupts from occurring between readings of the ACRH and ACRL, set the I bit in the condition code register (CCR) before reading ACRH and clear the I bit after reading ACRL.*

### 11.4 Input Capture Registers

The input capture function is a means to record the time at which an event occurs. The source of the event can be the change on an external pin (PB3/AN3/TCAP) or the CPF2 flag bit of voltage comparator 2 in the analog subsystem. The ICEN bit in the analog subsystem control register (ACR) at \$001D selects which source is the input signal. When the input capture circuitry detects an active edge on the selected source, it latches the contents of the free-running timer counter registers into the input capture registers as shown in Figure 11-6.

**NOTE**

*Both the ICEN bit in the ACR and the IEDG bit in the TCR must be set when using voltage comparator 2 to trigger the input capture function.*

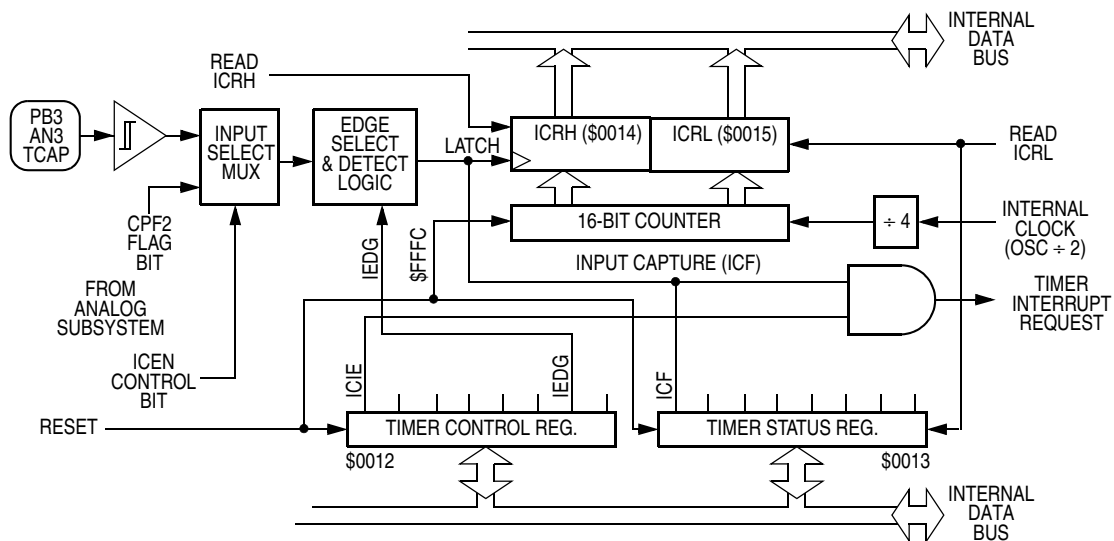
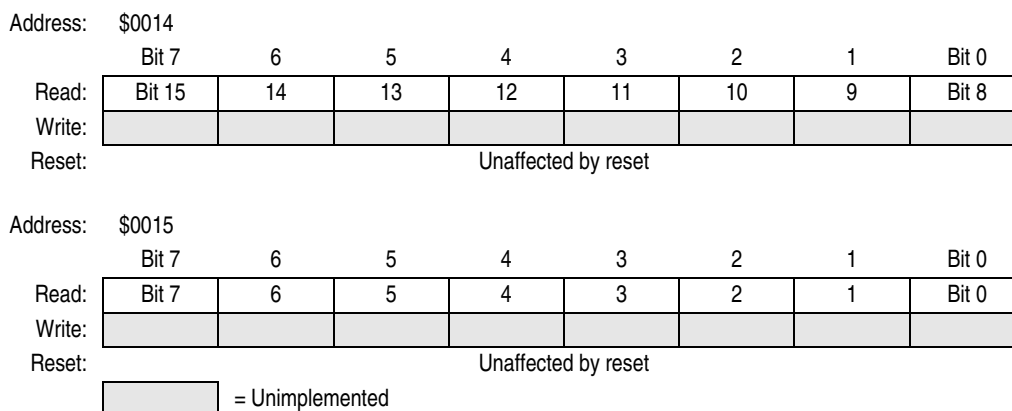

**Figure 11-6. Timer Input Capture Block Diagram**

Latching values into the input capture registers at successive edges of the same polarity measures the period of the selected input signal. Latching the counter values at successive edges of opposite polarity measures the pulse width of the signal.

## Programmable Timer

The input capture registers are made up of two 8-bit read-only registers (ICRH and ICRL) as shown in Figure 11-7. The input capture edge detector contains a Schmitt trigger to improve noise immunity. The edge that triggers the counter transfer is defined by the input edge bit (IEDG) in the TCR. Reset does not affect the contents of the input capture registers.



**Figure 11-7. Input Capture Registers (ICRH and ICRL)**

The result obtained by an input capture will be one count higher than the value of the free-running timer counter preceding the external transition. This delay is required for internal synchronization. Resolution is affected by the prescaler, allowing the free-running timer counter to increment once every four internal clock cycles (eight oscillator clock cycles).

Reading the ICRH inhibits future captures until the ICRL is also read. Reading the ICRL after reading the timer status register (TSR) clears the ICF flag bit. There is no conflict between reading the ICRL and transfers from the free-running timer counters. The input capture registers always contain the free-running timer counter value which corresponds to the most recent input capture.

### NOTE

*To prevent interrupts from occurring between readings of the ICRH and ICRL, set the I bit in the condition code register (CCR) before reading ICRH and clear the I bit after reading ICRL.*

## 11.5 Output Compare Registers

The output compare function is a means of generating an output signal when the 16-bit timer counter reaches a selected value as shown in Figure 11-8. Software writes the selected value into the output compare registers. On every fourth internal clock cycle (every eight oscillator clock cycles) the output compare circuitry compares the value of the free-running timer counter to the value written in the output compare registers. When a match occurs, the timer transfers the output level (OLVL) from the timer control register (TCR) to the PB4/AN4/TCMP pin.

Software can use the output compare register to measure time periods, to generate timing delays, or to generate a pulse of specific duration or a pulse train of specific frequency and duty cycle on the PB4/AN4/TCMP pin.

The planned action on the PB4/AN4/TCMP pin depends on the value stored in the OLVL bit in the TCR, and it occurs when the value of the 16-bit free-running timer counter matches the value in the output compare registers shown in Figure 11-9. These registers are read/write bits and are unaffected by reset.

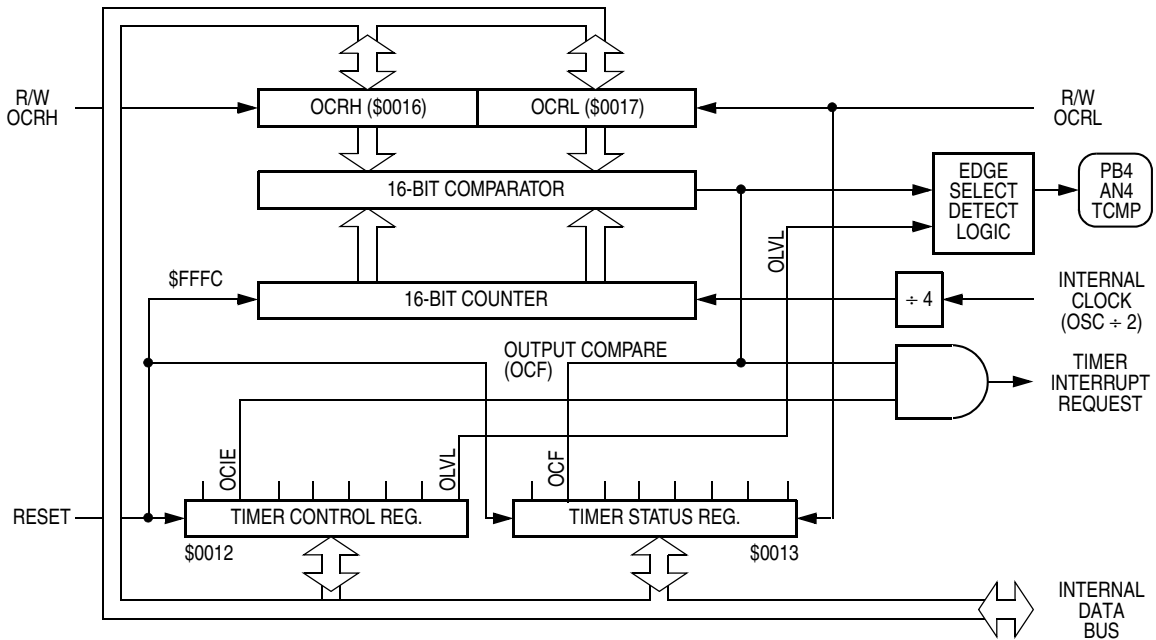

Figure 11-8. Timer Output Compare Block Diagram

Address:	\$0016							
	Bit 7	6	5	4	3	2	1	Bit 0
Read:	Bit 15	14	13	12	11	10	9	Bit 8
Write:	Bit 15	14	13	12	11	10	9	Bit 8
Reset:	Unaffected by reset							

Address:	\$0017							
	Bit 7	6	5	4	3	2	1	Bit 0
Read:	Bit 7	6	5	4	3	2	1	Bit 0
Write:	Bit 7	6	5	4	3	2	1	Bit 0
Reset:	Unaffected by reset							

Figure 11-9. Output Compare Registers (OCRH and OCRL)

Writing to the OCRH before writing to the OCRL inhibits timer compares until the OCRL is written. Reading or writing to the OCRL after reading the TCR will clear the output compare flag bit (OCF). The output compare OLV state will be clocked to its output latch regardless of the state of the OCF.

To prevent OCF from being set between the time it is read and the time the output compare registers are updated, use this procedure:

1. Disable interrupts by setting the I bit in the condition code register.
2. Write to the OCRH. Compares are now inhibited until OCRL is written.
3. Read the TSR to arm the OCF for clearing.
4. Enable the output compare registers by writing to the OCRL. This also clears the OCF flag bit in the TSR.
5. Enable interrupts by clearing the I bit in the condition code register.

A software example of this procedure is shown in [Table 11-1](#).

**Table 11-1. Output Compare Initialization Example**

9B		SEI		DISABLE INTERRUPTS
...		...		.....
...		...		.....
B7	16	STA	OCRH	INHIBIT OUTPUT COMPARE
B6	13	LDA	TSR	ARM OCF FLAG FOR CLEARING
BF	17	STX	OCRL	READY FOR NEXT COMPARE, OCF CLEARED
...		...		.....
...		...		.....
9A		CLI		ENABLE INTERRUPTS

## 11.6 Timer Control Register

The timer control register (TCR) shown in [Figure 11-10](#), performs the following functions:

- Enables input capture interrupts
- Enables output compare interrupts
- Enables timer overflow interrupts
- Controls the active edge polarity of the TCAP signal
- Controls the active level of the TCMP output

Reset clears all the bits in the TCR with the exception of the IEDG bit which is unaffected.

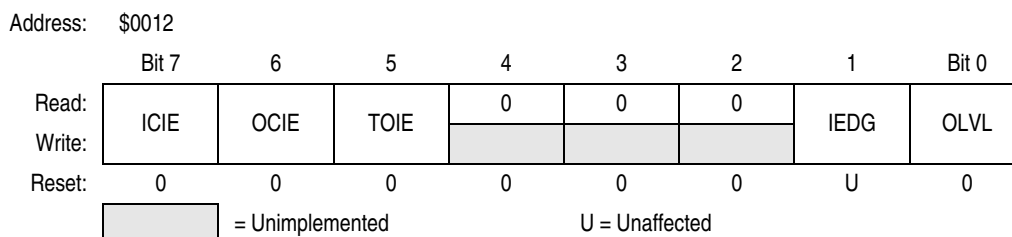

**Figure 11-10. Timer Control Register (TCR)**

### ICIE — Input Capture Interrupt Enable Bit

This read/write bit enables interrupts caused by an active signal on the TCAP pin or from CPF2 flag bit of the analog subsystem voltage comparator 2. Reset clears the ICIE bit.

- 1 = Input capture interrupts enabled
- 0 = Input capture interrupts disabled

### OCIE — Output Compare Interrupt Enable Bit

This read/write bit enables interrupts caused by an active match of the output compare function. Reset clears the OCIE bit.

- 1 = Output compare interrupts enabled
- 0 = Output compare interrupts disabled

### TOIE — Timer Overflow Interrupt Enable

This read/write bit enables interrupts caused by a timer overflow. Reset clears the TOIE bit.

- 1 = Timer overflow interrupts enabled
- 0 = Timer overflow interrupts disabled

### IEDG — Input Capture Edge Select

The state of this read/write bit determines whether a positive or negative transition triggers a transfer of the contents of the timer register to the input capture register. This transfer can occur due to transitions on the TCAP pin or the CPF2 flag bit of voltage comparator 2. Resets have no effect on the IEDG bit.

- 1 = Positive edge (low-to-high transition) triggers input capture
- 0 = Negative edge (high-to-low transition) triggers input capture

**NOTE**

*The IEDG bit must be set when either mode 2 or 3 of the analog subsystem is being used for A/D conversions. Otherwise, the input capture will not occur on the rising edge of the comparator 2 flag.*

### OLVL — Output Compare Output Level Select

The state of this read/write bit determines whether a logic 1 or a logic 0 is transferred to the TCMP pin when a successful output compare occurs. Reset clears the OLVL bit.

- 1 = Signal to TCMP pin goes high on output compare.
- 0 = Signal to TCMP pin goes low on output compare.

## 11.7 Timer Status Register

The timer status register (TSR) shown in Figure 11-11 contains flags for these events:

- An active signal on the TCAP pin or the CPF2 flag bit of voltage comparator 2 in the analog subsystem, transferring the contents of the timer registers to the input capture registers
- A match between the 16-bit counter and the output compare registers, transferring the OLVL bit to the PB4/AN4/TCMP pin if that pin is set as an output
- An overflow of the timer registers from \$FFFF to \$0000

Writing to any of the bits in the TSR has no effect. Reset does not change the state of any of the flag bits in the TSR.

Address: \$0013

	Bit 7	6	5	4	3	2	1	Bit 0
Read:	ICF	OCF	TOF	0	0	0	0	0
Write:								
Reset:	U	U	U	0	0	0	0	0

= Unimplemented
 U = Unaffected

**Figure 11-11. Timer Status Register (TSR)**

### ICF — Input Capture Flag

The ICF bit is automatically set when an edge of the selected polarity occurs on the TCAP pin. Clear the ICF bit by reading the timer status register with the ICF set, and then reading the low byte (ICRL, \$0015) of the input capture registers. Resets have no effect on ICF.

### OCF — Output Compare Flag

The OCF bit is automatically set when the value of the timer registers matches the contents of the output compare registers. Clear the OCF bit by reading the timer status register with the OCF set and then accessing the low byte (OCRL, \$0017) of the output compare registers. Resets have no effect on OCF.

### TOF — Timer Overflow Flag

The TOF bit is automatically set when the 16-bit timer counter rolls over from \$FFFF to \$0000. Clear the TOF bit by reading the timer status register with the TOF set and then accessing the low byte (TMRL, \$0019) of the timer registers. Resets have no effect on TOF.

## 11.8 Timer Operation during Wait Mode

During wait mode, the 16-bit timer continues to operate normally and may generate an interrupt to trigger the MCU out of wait mode.

## 11.9 Timer Operation during Stop Mode

When the MCU enters stop mode, the free-running counter stops counting (the internal processor clock is stopped). It remains at that particular count value until stop mode is exited by applying a low signal to the  $\overline{\text{IRQ}}/V_{\text{PP}}$  pin, at which time the counter resumes from its stopped value as if nothing had happened. If stop mode is exited via an external reset (logic low applied to the  $\overline{\text{RESET}}$  pin), the counter is forced to \$FFFC.

If a valid input capture edge occurs during stop mode, the input capture detect circuitry will be armed. This action does not set any flags or wake up the MCU, but when the MCU does wake up there will be an active input capture flag (and data) from the first valid edge. If the stop mode is exited by an external reset, no input capture flag or data will be present even if a valid input capture edge was detected during stop mode.

## 11.10 Timer Operation during Halt Mode

When the MCU enters halt mode, the functions and states of the 16-bit programmable timer are the same as for wait mode described in [11.8 Timer Operation during Wait Mode](#).

# Chapter 12

## Personality EPROM (PEPROM)

### 12.1 Introduction

This section describes how to program the 64-bit personality erasable programmable read-only memory (PEPROM). Figure 12-1 shows the structure of the PEPROM subsystem.

**NOTE**

*In packages with no quartz window, the PEPROM functions as one-time programmable ROM (OTPROM).*

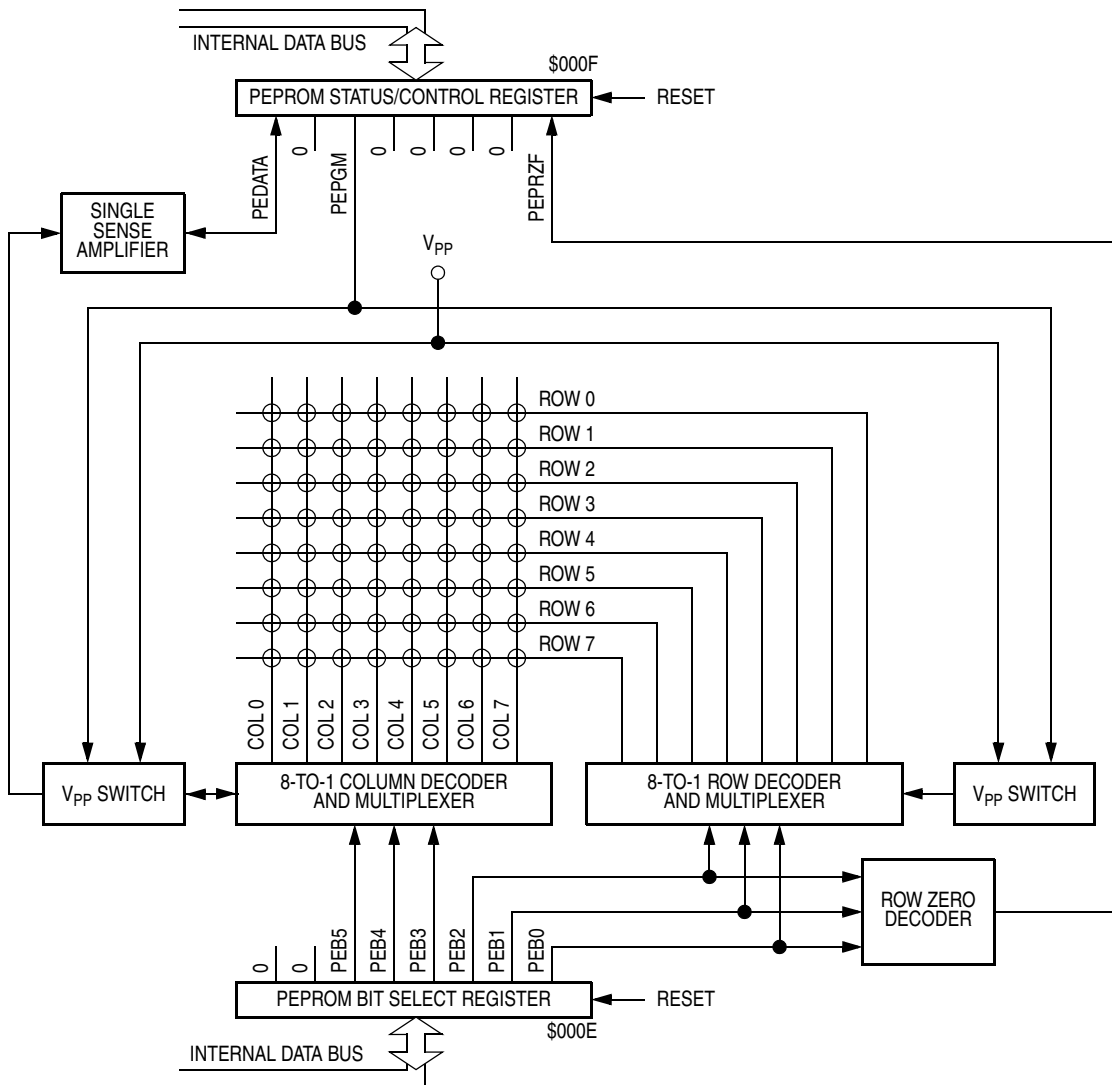

**Figure 12-1. Personality EPROM Block Diagram**

## 12.2 PEPROM Registers

Two I/O registers control programming and reading of the PEPROM:

- The PEPROM bit select register (PEBSR)
- The PEPROM status and control register (PESCR)

### 12.2.1 PEPROM Bit Select Register

The PEPROM bit select register (PEBSR) selects one of 64 bits in the PEPROM array. Reset clears all the bits in the PEPROM bit select register.

Address:	\$000E							
	Bit 7	6	5	4	3	2	1	Bit 0
Read:	PEB7	PEB6	PEB5	PEB4	PEB3	PEB2	PEB1	PEB0
Write:								
Reset:	0	0	0	0	0	0	0	0

**Figure 12-2. PEPROM Bit Select Register (PEBSR)**

#### PEB7 and PEB6 — Not connected to the PEPROM array

These read/write bits are available as storage locations. Reset clears PEB7 and PEB6.

#### PEB5–PEB0 — PEPROM Bit Selects

These read/write bits select one of 64 bits in the PEPROM as shown in [Table 12-1](#). Bits PEB2–0 select the PEPROM row, and bits PEB5–PEB3 select the PEPROM column. Reset clears PEB5–PEB0, selecting the PEPROM bit in row zero, column zero.

### 12.2.2 PEPROM Status and Control Register

The PEPROM status and control register (PESCR) controls the PEPROM programming voltage. This register also transfers the PEPROM bits to the internal data bus and contains a flag bit when row zero is selected.

Address:	\$000F							
	Bit 7	6	5	4	3	2	1	Bit 0
Read:	PEDATA	0	PEPGM	0	0	0	0	PEPRZF
Write:					R	R	R	
Reset:	U	0	0	0	0	0	0	1

  = Unimplemented     
 R = Reserved     
 U = Unaffected

**Figure 12-3. PEPROM Status and Control Register (PESCR)**

#### PEDATA — PEPROM Data Bit

This read-only bit is the output state of the PEPROM sense amplifier and shows the state of the currently selected bit. The state of the PEDATA bit does not affect the programming of the bit selected by the PEBSR. Reset does not affect the PEDATA bit.

- 1 = PEPROM data is a logic 1.
- 0 = PEPROM data is a logic 0.

**PEPGM — PEPROM Program Control Bit**

This read/write bit controls the switches that apply the programming voltage from the  $\overline{IRQ}/V_{PP}$  pin to the selected PEPROM bit cell. When the PEPGM bit is set, the selected bit cell will be programmed to a logic 1, regardless of the state of the PEDATA bit. Reset clears the PEPGM bit.

- 1 = Programming voltage applied to array bit
- 0 = Programming voltage not applied to array bit

**PEPRZF — PEPROM Row Zero Flag**

This read-only bit is set when the PEPROM bit select register selects the first row (row zero) of the PEPROM array. Selecting any other row clears PEPRZF. Monitoring PEPRZF can reduce the code needed to access one byte of eight PEPROM locations. Reset clears the PEPROM bit select register, thereby setting the PEPRZF bit by default.

- 1 = Row zero selected
- 0 = Row zero not selected

**Table 12-1. PEPROM Bit Selection**

PEBSR	PEPROM Bit Selected	
\$00	Row 0	Column 0
\$01	Row 1	Column 0
V	V	V
\$07	Row 7	Column 0
\$08	Row 0	Column 1
\$09	Row 1	Column 1
V	V	V
\$37	Row 7	Column 6
\$38	Row 0	Column 7
\$39	Row 1	Column 7
V	V	V
\$3E	Row 6	Column 7
\$3F	Row 7	Column 7

**12.3 PEPROM Programming**

Factory-provided software for programming the PEPROM is available on the World Wide Web at: <http://www.freescale.com>

**NOTE**

*While the PEPGM bit is set and the  $V_{PP}$  voltage level is applied to the  $\overline{IRQ}/V_{PP}$  pin, do not access bits that are to be left unprogrammed (erased).  
To program the PEPROM bits properly, the  $V_{DD}$  voltage must be greater than 4.5 Vdc.*

The PEPROM can also be programmed by user software with the  $V_{PP}$  voltage level applied to the  $\overline{IRQ}/V_{PP}$  pin. This sequence shows how to program each PEPROM bit:

1. Select a PEPROM bit by writing to the PEBSR.
2. Set the PEPGM bit in the PESCR.
3. Wait for the programming time,  $t_{EPGM}$ .
4. Clear the PEPGM bit.
5. Move to next PEPROM bit to be programmed in step 1.

## 12.4 PEPROM Reading

This sequence shows how to read the PEPROM:

1. Select a bit by writing to the PEBSR.
2. Read the PEDATA bit in the PESCR.
3. Store the PEDATA bit in RAM or in a register.
4. Select another bit by changing the PEBSR.
5. Continue reading and storing the PEDATA bits until the required personality EPROM data is retrieved and stored.

Reading the PEPROM is easiest when each PEPROM column contains one byte. Selecting a row 0 bit selects the first bit, and incrementing the PEPROM bit select register (PEBSR) selects the next bit in row 1 from the same column. Incrementing PEBSR seven more times selects the remaining bits of the column and ends up selecting the bit in row 0 of the next column, thereby setting the row 0 flag, PEPRZF.

### **NOTE**

*A PEPROM byte that has been read can be transferred to the personality EPROM bit select register (PEBSR) as a temporary storage location such that subsequent reads of the PEBSR quickly yield that PEPROM byte.*

## 12.5 PEPROM Erasing

MCUs with windowed packages permit PEPROM erasing with ultraviolet light. Erase the PEPROM by exposing it to  $15 \text{ Ws/cm}^2$  of ultraviolet light with a wavelength of 2537 angstroms. Position the ultraviolet light source 1 inch from the window. Do not use a shortwave filter. The erased state of a PEPROM bit is a logic 0.

# Chapter 13

## EPROM/OTPROM

### 13.1 Introduction

This section describes how to program the 6160-byte erasable programmable read-only memory/one-time programmable read-only memory (EPROM/OTPROM), the mask option register (MOR), and the EPROM security bit (EPMSEC).

**NOTE**

*In packages with no quartz window, the EPROM functions as one-time programmable ROM (OTPROM).*

### 13.2 EPROM Registers

The EPROM programming register (EPROG) controls the actual programming of the EPROM bytes and the mask option register (MOR). The MOR controls eight mask options found on the read-only memory (ROM) version of this microcontroller unit (MCU). There is an additional EPROM bit (EPMSEC) located at the computer operating properly (COP) address to provide EPROM array security.

#### 13.2.1 EPROM Programming Register

The EPROM programming register (EPROG) shown in [Figure 13-1](#) contains the control bits for programming the EPROM. In normal operation, the EPROM programming register contains all logic 0s.

Address: \$001C

	Bit 7	6	5	4	3	2	1	Bit 0
Read:	0	0	0	0	0	ELAT		MPGM
Write:		R	R	R	R			EPGM
Reset:	0	0	0	0	0	0	0	0

  = Unimplemented
 R = Reserved for test

**Figure 13-1. EPROM Programming Register (EPROG)**

#### EPGM — EPROM Programming Bit

This read/write bit applies the voltage from the  $\overline{\text{IRQ}}/V_{\text{PP}}$  pin to the EPROM. To write the EPGM bit, the ELAT bit must already be set. Clearing the ELAT bit also clears the EPGM bit. Reset clears EPGM.

- 1 = EPROM programming power switched on
- 0 = EPROM programming power switched off

#### MPGM — Mask Option Register (MOR) Programming Bit

This read/write bit applies programming power from the  $\overline{\text{IRQ}}/V_{\text{PP}}$  pin to the MOR. Reset clears MPGM.

- 1 = MOR programming power switched on
- 0 = MOR programming power switched off

**ELAT — EPROM Bus Latch Bit**

This read/write bit configures address and data buses for programming the EPROM array. EPROM data cannot be read when ELAT is set. Clearing the ELAT bit also clears the EPGM bit. Reset clears ELAT.

- 1 = Address and data buses configured for EPROM programming of the array. The address and data buses are latched in the EPROM array when a subsequent write to the array is made. Data in the EPROM array cannot be read.
- 0 = Address and data buses configured for normal operation

Whenever the ELAT bit is cleared, the EPGM bit is also cleared. Both the EPGM and the ELAT bit cannot be set using the same write instruction. Any attempt to set both the ELAT and EPGM bit on the same write instruction cycle will result in the ELAT bit being set and the EPGM bit being cleared. To program a byte of EPROM, manipulate the EPROG register as follows:

1. Set the ELAT bit in the EPROG register.
2. Write the desired data to the desired EPROM address.
3. Set the EPGM bit in the EPROG register for the specified programming time,  $t_{EPGM}$ .
4. Clear the ELAT and EPGM bits in the EPROG register.

**13.2.2 Mask Option Register**

The mask option register (MOR) shown in Figure 13-2 is an EPROM byte that controls eight mask options. The MOR is unaffected by reset. The erased state of the MOR is \$00. The options that can be programmed by the MOR are:

1. Port software programmable pulldown devices (enable or disable)
2. Startup delay after stop (16 or 4064 cycles)
3. Oscillator shunt resistor (2 MΩ or open)
4. STOP instruction (enable or disable)
5. Low-voltage reset (enable or disable)
6. Port A external interrupt function (enable or disable)
7. IRQ trigger sensitivity (edge-triggered only or both edge- and level-triggered)
8. COP watchdog (enable or disable)

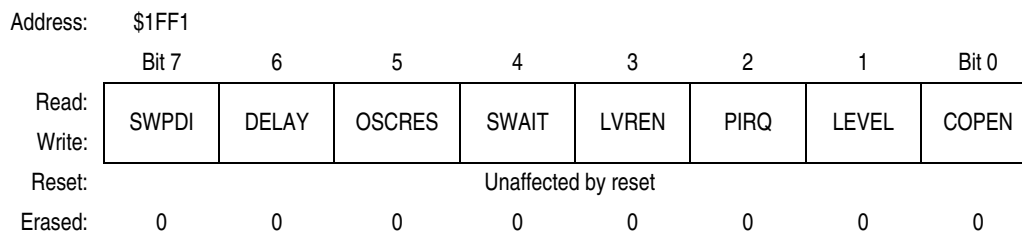

**Figure 13-2. Mask Option Register (MOR)**

**SWPDI — Software Pulldown Inhibit Bit**

This EPROM bit inhibits software control of the port A and port B pulldown devices.

- 1 = Software pulldown inhibited
- 0 = Software pulldown enabled

**DELAY — Stop Startup Delay Bit**

This EPROM bit selects the number of bus cycles that must elapse before bus activity begins following a restart from the stop mode.

- 1 = Startup delay is 4064 bus cycles.
- 0 = Startup delay is 16 bus cycles.

**CAUTION**

*The 16-cycle delay option will work properly in devices with the internal low-power oscillator or with a steady external clock source. Check crystal/ceramic resonator specifications carefully before using the 16-cycle delay option with a crystal or ceramic resonator.*

**OSCRES — Oscillator Resistor Bit**

This EPROM bit configures the internal shunt resistor.

- 1 = Oscillator configured with 2 M<sup>3</sup>/<sub>4</sub> shunt resistor
- 0 = Oscillator configured without a shunt resistor

**NOTE**

*The optional oscillator resistor is NOT recommended for devices that use an external RC oscillator. For such devices, this bit should be left erased as a 0.*

**SWAIT — STOP Conversion to WAIT Bit**

This EPROM bit disables the STOP instruction and prevents inadvertently turning off the COP watchdog with a STOP instruction. When the SWAIT bit is set, a STOP instruction puts the MCU in halt mode. Halt mode is a wait-like low-power state. The internal oscillator and timer clock continue to run, but the CPU clock stops. When the SWAIT bit is clear, a STOP instruction stops the internal oscillator, the internal clock, the CPU clock, the timer clock, and the COP watchdog timer.

- 1 = STOP instruction converted to WAIT instruction
- 0 = STOP instruction not converted to WAIT instruction

**LVREN — Low-Voltage Reset Enable Bit**

This EPROM bit enables the low-voltage reset (LVR) function.

- 1 = LVR function enabled
- 0 = LVR function disabled

**PIRQ — Port A IRQ Enable Bit**

This EPROM bit enables the PA3–PA0 pins to function as external interrupt sources.

- 1 = PA3–PA0 enabled as external interrupt sources
- 0 = PA3–PA0 not enabled as external interrupt sources

**LEVEL — External Interrupt Sensitivity Bit**

This EPROM bit makes the external interrupt inputs level-triggered as well as edge-triggered

- 1 =  $\overline{IRQ}/V_{PP}$  pin negative-edge triggered and low-level triggered;  
PA3–PA0 pins positive-edge triggered and high-level triggered
- 0 =  $\overline{IRQ}/V_{PP}$  pin negative-edge triggered only; PA3–PA0 pins positive-edge triggered only

**COPEN — COP Watchdog Enable Bit**

This EPROM bit enables the COP watchdog.

- 1 = COP watchdog enabled
- 0 = COP watchdog disabled

### 13.2.3 EPROM Security Bit

An EPROM programmable bit is provided at the location of the COP watchdog register at \$1FF0 as shown in Figure 13-3. This bit allows control of access to the EPROM array. Any accesses of the EPROM locations will return undefined results when the EPMSEC bit is set. Refer to 13.3.2 EPMSEC Programming for programming instructions.

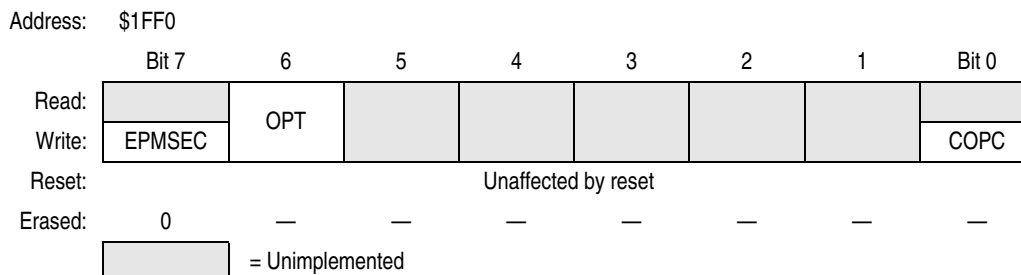

**Figure 13-3. EPROM Security in COP and Security Register (COPR)**

#### EPMSEC — EPROM Security<sup>(1)</sup>

This EPROM write-only bit enables the access to the EPROM array.

- 1 = Access to the EPROM array in non-user modes is denied.
- 0 = Access to the EPROM array in non-user modes is enabled.

### 13.3 EPROM Programming

A programming board is available from Freescale to download to the on-chip EPROM/OTPROM using the factory-provided programming software. Factory-provided software for programming the PEPROM is available on the World Wide Web at:

<http://www.freescale.com>

The programming software copies to the 6144-byte space located at EPROM addresses \$0700–\$1EFF and to the 16-byte space at addresses \$1FF0–\$1FFF which includes the mask option register at address \$1FF1, and the security bit at address \$1FF0.

**NOTE**

*To program the EPROM/OTPROM, MOR, or EPMSEC bits properly, the  $V_{DD}$  voltage must be greater than 4.5 volts.*

1. No security feature is absolutely secure. However, Freescale’s strategy is to make reading or copying the EPROM/OTPROM difficult for unauthorized users.

### 13.3.1 MOR Programming

The contents of the MOR should be programmed using the programmer board. To program any bits in the MOR, the desired bit states must be written to the MOR address and then the MPGM bit in the EPROG register must be used. The following sequence will program the MOR:

1. Write the desired data to the MOR location (\$1FF1).
2. Apply the programming voltage to the  $\overline{\text{IRQ}}/V_{\text{PP}}$  pin.
3. Set the MPGM bit in the EPROG.
4. Wait for the programming time,  $t_{\text{MPGM}}$ .
5. Clear the MPGM bit in the EPROG.
6. Remove the programming voltage from the  $\overline{\text{IRQ}}/V_{\text{PP}}$  pin.

Once the MOR bits have been programmed, some of the options may experience glitches in operation after removal of the programming voltage. It is recommended that the part be reset before trying to verify the contents of the user EPROM or the MOR itself.

#### **NOTE**

*The contents of the EPROM or the MOR cannot be accessed if the EPMSEC bit in the COPR register has been set.*

### 13.3.2 EPMSEC Programming

The EPMSEC bit is programmable. To program the EPMSEC bit, the desired state must be written to the COP address and then the MPGM bit in the EPROG register must be used. The following sequence will program the EPMSEC bit:

1. Write the desired data to bit 7 of the COPR location (\$1FF0).
2. Apply the programming voltage to the  $\overline{\text{IRQ}}/V_{\text{PP}}$  pin.
3. Set the MPGM bit in the EPROG.
4. Wait for the programming time,  $t_{\text{MPGM}}$ .
5. Clear the MPGM bit in the EPROG.
6. Remove the programming voltage from the  $\overline{\text{IRQ}}/V_{\text{PP}}$  pin.

Once the EPMSEC bit has been programmed to a logic 1, access to the contents of the EPROM and MOR in the expanded non-user modes will be denied. It is therefore recommended that the user EPROM and MOR in the part first be programmed and fully verified before setting the EPMSEC bit.

## 13.4 EPROM Erasing

MCUs with windowed packages permit EPROM erasing with ultraviolet light. Erase the EPROM by exposing it to  $15 \text{ Ws/cm}^2$  of ultraviolet light with a wavelength of 2537 angstroms. Position the ultraviolet light source 1 inch from the window. Do not use a shortwave filter. The erased state of an EPROM bit is a logic 0.

#### **NOTE**

*Unlike many commercial EPROMs, an erased EPROM byte in the MCU will read as \$00. All unused locations should be programmed as 0s.*



# Chapter 14

## Instruction Set

### 14.1 Introduction

The microcontroller unit (MCU) instruction set has 62 instructions and uses eight addressing modes. The instructions include all those of the M146805 CMOS Family plus one more: the unsigned multiply (MUL) instruction. The MUL instruction allows unsigned multiplication of the contents of the accumulator (A) and the index register (X). The high-order product is stored in the index register, and the low-order product is stored in the accumulator.

### 14.2 Addressing Modes

The CPU uses eight addressing modes for flexibility in accessing data. The addressing modes provide eight different ways for the CPU to find the data required to execute an instruction. The eight addressing modes are:

- Inherent
- Immediate
- Direct
- Extended
- Indexed, no offset
- Indexed, 8-bit offset
- Indexed, 16-bit offset
- Relative

#### 14.2.1 Inherent

Inherent instructions are those that have no operand, such as return from interrupt (RTI) and stop (STOP). Some of the inherent instructions act on data in the CPU registers, such as set carry flag (SEC) and increment accumulator (INCA). Inherent instructions require no operand address and are one byte long.

#### 14.2.2 Immediate

Immediate instructions are those that contain a value to be used in an operation with the value in the accumulator or index register. Immediate instructions require no operand address and are two bytes long. The opcode is the first byte, and the immediate data value is the second byte.

#### 14.2.3 Direct

Direct instructions can access any of the first 256 memory locations with two bytes. The first byte is the opcode, and the second is the low byte of the operand address. In direct addressing, the CPU automatically uses \$00 as the high byte of the operand address.

### 14.2.4 Extended

Extended instructions use three bytes and can access any address in memory. The first byte is the opcode; the second and third bytes are the high and low bytes of the operand address.

When using the Freescale assembler, the programmer does not need to specify whether an instruction is direct or extended. The assembler automatically selects the shortest form of the instruction.

### 14.2.5 Indexed, No Offset

Indexed instructions with no offset are 1-byte instructions that can access data with variable addresses within the first 256 memory locations. The index register contains the low byte of the effective address of the operand. The CPU automatically uses \$00 as the high byte, so these instructions can address locations \$0000–\$00FF.

Indexed, no offset instructions are often used to move a pointer through a table or to hold the address of a frequently used random-access memory (RAM) or input/output (I/O) location.

### 14.2.6 Indexed, 8-Bit Offset

Indexed, 8-bit offset instructions are 2-byte instructions that can access data with variable addresses within the first 511 memory locations. The CPU adds the unsigned byte in the index register to the unsigned byte following the opcode. The sum is the effective address of the operand. These instructions can access locations \$0000–\$01FE.

Indexed 8-bit offset instructions are useful for selecting the *k*th element in an *n*-element table. The table can begin anywhere within the first 256 memory locations and could extend as far as location 510 (\$01FE). The *k* value is typically in the index register, and the address of the beginning of the table is in the byte following the opcode.

### 14.2.7 Indexed, 16-Bit Offset

Indexed, 16-bit offset instructions are 3-byte instructions that can access data with variable addresses at any location in memory. The CPU adds the unsigned byte in the index register to the two unsigned bytes following the opcode. The sum is the effective address of the operand. The first byte after the opcode is the high byte of the 16-bit offset; the second byte is the low byte of the offset.

Indexed, 16-bit offset instructions are useful for selecting the *k*th element in an *n*-element table anywhere in memory.

As with direct and extended addressing, the Freescale assembler determines the shortest form of indexed addressing.

### 14.2.8 Relative

Relative addressing is only for branch instructions. If the branch condition is true, the CPU finds the effective branch destination by adding the signed byte following the opcode to the contents of the program counter. If the branch condition is not true, the CPU goes to the next instruction. The offset is a signed, two's complement byte that gives a branching range of –128 to +127 bytes from the address of the next location after the branch instruction.

When using the Freescale assembler, the programmer does not need to calculate the offset, because the assembler determines the proper offset and verifies that it is within the span of the branch.

## 14.3 Instruction Types

The MCU instructions fall into the following five categories:

- Register/memory instructions
- Read-modify-write instructions
- Jump/branch instructions
- Bit manipulation instructions
- Control instructions

### 14.3.1 Register/Memory Instructions

These instructions operate on CPU registers and memory locations. Most of them use two operands. One operand is in either the accumulator or the index register. The CPU finds the other operand in memory.

**Table 14-1. Register/Memory Instructions**

Instruction	Mnemonic
Add Memory Byte and Carry Bit to Accumulator	ADC
Add Memory Byte to Accumulator	ADD
AND Memory Byte with Accumulator	AND
Bit Test Accumulator	BIT
Compare Accumulator	CMP
Compare Index Register with Memory Byte	CPX
EXCLUSIVE OR Accumulator with Memory Byte	EOR
Load Accumulator with Memory Byte	LDA
Load Index Register with Memory Byte	LDX
Multiply	MUL
OR Accumulator with Memory Byte	ORA
Subtract Memory Byte and Carry Bit from Accumulator	SBC
Store Accumulator in Memory	STA
Store Index Register in Memory	STX
Subtract Memory Byte from Accumulator	SUB

### 14.3.2 Read-Modify-Write Instructions

These instructions read a memory location or a register, modify its contents, and write the modified value back to the memory location or to the register.

**NOTE**

*Do not use read-modify-write operations on write-only registers.*

**Table 14-2. Read-Modify-Write Instructions**

Instruction	Mnemonic
Arithmetic Shift Left (Same as LSL)	ASL
Arithmetic Shift Right	ASR
Bit Clear	BCLR <sup>(1)</sup>
Bit Set	BSET <sup>(1)</sup>
Clear Register	CLR
Complement (One's Complement)	COM
Decrement	DEC
Increment	INC
Logical Shift Left (Same as ASL)	LSL
Logical Shift Right	LSR
Negate (Two's Complement)	NEG
Rotate Left through Carry Bit	ROL
Rotate Right through Carry Bit	ROR
Test for Negative or Zero	TST <sup>(2)</sup>

1. Unlike other read-modify-write instructions, BCLR and BSET use only direct addressing.
2. TST is an exception to the read-modify-write sequence because it does not write a replacement value.

### 14.3.3 Jump/Branch Instructions

Jump instructions allow the CPU to interrupt the normal sequence of the program counter. The unconditional jump instruction (JMP) and the jump-to-subroutine instruction (JSR) have no register operand. Branch instructions allow the CPU to interrupt the normal sequence of the program counter when a test condition is met. If the test condition is not met, the branch is not performed.

The BRCLR and BRSET instructions cause a branch based on the state of any readable bit in the first 256 memory locations. These 3-byte instructions use a combination of direct addressing and relative addressing. The direct address of the byte to be tested is in the byte following the opcode. The third byte is the signed offset byte. The CPU finds the effective branch destination by adding the third byte to the program counter if the specified bit tests true. The bit to be tested and its condition (set or clear) is part of the opcode. The span of branching is from  $-128$  to  $+127$  from the address of the next location after the branch instruction. The CPU also transfers the tested bit to the carry/borrow bit of the condition code register.

**Table 14-3. Jump and Branch Instructions**

Instruction	Mnemonic
Branch if Carry Bit Clear	BCC
Branch if Carry Bit Set	BCS
Branch if Equal	BEQ
Branch if Half-Carry Bit Clear	BHCC
Branch if Half-Carry Bit Set	BHCS
Branch if Higher	BHI
Branch if Higher or Same	BHS
Branch if $\overline{\text{IRQ}}/\text{V}_{\text{PP}}$ Pin High	BIH
Branch if $\overline{\text{IRQ}}/\text{V}_{\text{PP}}$ Pin Low	BIL
Branch if Lower	BLO
Branch if Lower or Same	BLS
Branch if Interrupt Mask Clear	BMC
Branch if Minus	BMI
Branch if Interrupt Mask Set	BMS
Branch if Not Equal	BNE
Branch if Plus	BPL
Branch Always	BRA
Branch if Bit Clear	BRCLR
Branch Never	BRN
Branch if Bit Set	BRSET
Branch to Subroutine	BSR
Unconditional Jump	JMP
Jump to Subroutine	JSR

### 14.3.4 Bit Manipulation Instructions

The CPU can set or clear any writable bit in the first 256 bytes of memory, which includes I/O registers and on-chip RAM locations. The CPU can also test and branch based on the state of any bit in any of the first 256 memory locations.

**Table 14-4. Bit Manipulation Instructions**

Instruction	Mnemonic
Bit Clear	BCLR
Branch if Bit Clear	BRCLR
Branch if Bit Set	BRSET
Bit Set	BSET

### 14.3.5 Control Instructions

These instructions act on central processor unit (CPU) registers and control CPU operation during program execution.

**Table 14-5. Control Instructions**

Instruction	Mnemonic
Clear Carry Bit	CLC
Clear Interrupt Mask	CLI
No Operation	NOP
Reset Stack Pointer	RSP
Return from Interrupt	RTI
Return from Subroutine	RTS
Set Carry Bit	SEC
Set Interrupt Mask	SEI
Stop Oscillator and Enable $\overline{\text{IRQ}}/V_{PP}$ Pin	STOP
Software Interrupt	SWI
Transfer Accumulator to Index Register	TAX
Transfer Index Register to Accumulator	TXA
Stop CPU Clock and Enable Interrupts	WAIT

## 14.4 Instruction Set Summary

Table 14-6. Instruction Set Summary (Sheet 1 of 6)

Source Form	Operation	Description	Effect on CCR					Address Mode	Opcode	Operand	Cycles
			H	I	N	Z	C				
ADC #opr ADC opr ADC opr ADC opr,X ADC opr,X ADC ,X	Add with Carry	$A \leftarrow (A) + (M) + (C)$	†	—	†	†	†	IMM DIR EXT IX2 IX1 IX	A9 B9 C9 D9 E9 F9	ii dd hh ll ee ff ff	2 3 4 5 4 3
ADD #opr ADD opr ADD opr ADD opr,X ADD opr,X ADD ,X	Add without Carry	$A \leftarrow (A) + (M)$	†	—	†	†	†	IMM DIR EXT IX2 IX1 IX	AB BB CB DB EB FB	ii dd hh ll ee ff ff	2 3 4 5 4 3
AND #opr AND opr AND opr AND opr,X AND opr,X AND ,X	Logical AND	$A \leftarrow (A) \wedge (M)$	—	—	†	†	—	IMM DIR EXT IX2 IX1 IX	A4 B4 C4 D4 E4 F4	ii dd hh ll ee ff ff	2 3 4 5 4 3
ASL opr ASLA ASLX ASL opr,X ASL ,X	Arithmetic Shift Left (Same as LSL)		—	—	†	†	†	DIR INH INH IX1 IX	38 48 58 68 78	dd  ff	5 3 3 6 5
ASR opr ASRA ASRX ASR opr,X ASR ,X	Arithmetic Shift Right		—	—	†	†	†	DIR INH INH IX1 IX	37 47 57 67 77	dd  ff	5 3 3 6 5
BCC rel	Branch if Carry Bit Clear	$PC \leftarrow (PC) + 2 + rel ? C = 0$	—	—	—	—	—	REL	24	rr	3
BCLR n opr	Clear Bit n	$M_n \leftarrow 0$	—	—	—	—	—	DIR (b0) DIR (b1) DIR (b2) DIR (b3) DIR (b4) DIR (b5) DIR (b6) DIR (b7)	11 13 15 17 19 1B 1D 1F	dd dd dd dd dd dd dd dd	5 5 5 5 5 5 5 5
BCS rel	Branch if Carry Bit Set (Same as BLO)	$PC \leftarrow (PC) + 2 + rel ? C = 1$	—	—	—	—	—	REL	25	rr	3
BEQ rel	Branch if Equal	$PC \leftarrow (PC) + 2 + rel ? Z = 1$	—	—	—	—	—	REL	27	rr	3
BHCC rel	Branch if Half-Carry Bit Clear	$PC \leftarrow (PC) + 2 + rel ? H = 0$	—	—	—	—	—	REL	28	rr	3
BHCS rel	Branch if Half-Carry Bit Set	$PC \leftarrow (PC) + 2 + rel ? H = 1$	—	—	—	—	—	REL	29	rr	3
BHI rel	Branch if Higher	$PC \leftarrow (PC) + 2 + rel ? C \vee Z = 0$	—	—	—	—	—	REL	22	rr	3

Table 14-6. Instruction Set Summary (Sheet 2 of 6)

Source Form	Operation	Description	Effect on CCR					Address Mode	Opcode	Operand	Cycles
			H	I	N	Z	C				
BHS <i>rel</i>	Branch if Higher or Same	$PC \leftarrow (PC) + 2 + rel ? C = 0$	—	—	—	—	—	REL	24	rr	3
BIH <i>rel</i>	Branch if $\overline{IRQ}$ Pin High	$PC \leftarrow (PC) + 2 + rel ? \overline{IRQ} = 1$	—	—	—	—	—	REL	2F	rr	3
BIL <i>rel</i>	Branch if $\overline{IRQ}$ Pin Low	$PC \leftarrow (PC) + 2 + rel ? \overline{IRQ} = 0$	—	—	—	—	—	REL	2E	rr	3
BIT # <i>opr</i> BIT <i>opr</i> BIT <i>opr</i> BIT <i>opr,X</i> BIT <i>opr,X</i> BIT <i>,X</i>	Bit Test Accumulator with Memory Byte	(A) ^ (M)	—	—	†	†	—	IMM DIR EXT IX2 IX1 IX	A5 B5 C5 D5 E5 F5	ii dd hh ll ee ff ff p	2 3 4 5 4 3
BLO <i>rel</i>	Branch if Lower (Same as BCS)	$PC \leftarrow (PC) + 2 + rel ? C = 1$	—	—	—	—	—	REL	25	rr	3
BLS <i>rel</i>	Branch if Lower or Same	$PC \leftarrow (PC) + 2 + rel ? C \vee Z = 1$	—	—	—	—	—	REL	23	rr	3
BMC <i>rel</i>	Branch if Interrupt Mask Clear	$PC \leftarrow (PC) + 2 + rel ? I = 0$	—	—	—	—	—	REL	2C	rr	3
BMI <i>rel</i>	Branch if Minus	$PC \leftarrow (PC) + 2 + rel ? N = 1$	—	—	—	—	—	REL	2B	rr	3
BMS <i>rel</i>	Branch if Interrupt Mask Set	$PC \leftarrow (PC) + 2 + rel ? I = 1$	—	—	—	—	—	REL	2D	rr	3
BNE <i>rel</i>	Branch if Not Equal	$PC \leftarrow (PC) + 2 + rel ? Z = 0$	—	—	—	—	—	REL	26	rr	3
BPL <i>rel</i>	Branch if Plus	$PC \leftarrow (PC) + 2 + rel ? N = 0$	—	—	—	—	—	REL	2A	rr	3
BRA <i>rel</i>	Branch Always	$PC \leftarrow (PC) + 2 + rel ? 1 = 1$	—	—	—	—	—	REL	20	rr	3
BRCLR <i>n opr rel</i>	Branch if bit n clear	$PC \leftarrow (PC) + 2 + rel ? Mn = 0$	—	—	—	—	†	DIR (b0)	01	dd rr	5
								DIR (b1)	03	dd rr	5
								DIR (b2)	05	dd rr	5
								DIR (b3)	07	dd rr	5
								DIR (b4)	09	dd rr	5
								DIR (b5)	0B	dd rr	5
								DIR (b6)	0D	dd rr	5
								DIR (b7)	0F	dd rr	5
BRSET <i>n opr rel</i>	Branch if Bit n Set	$PC \leftarrow (PC) + 2 + rel ? Mn = 1$	—	—	—	—	†	DIR (b0)	00	dd rr	5
								DIR (b1)	02	dd rr	5
								DIR (b2)	04	dd rr	5
								DIR (b3)	06	dd rr	5
								DIR (b4)	08	dd rr	5
								DIR (b5)	0A	dd rr	5
								DIR (b6)	0C	dd rr	5
								DIR (b7)	0E	dd rr	5
BRN <i>rel</i>	Branch Never	$PC \leftarrow (PC) + 2 + rel ? 1 = 0$	—	—	—	—	—	REL	21	rr	3
BSET <i>n opr</i>	Set Bit n	$Mn \leftarrow 1$	—	—	—	—	—	DIR (b0)	10	dd	5
								DIR (b1)	12	dd	5
								DIR (b2)	14	dd	5
								DIR (b3)	16	dd	5
								DIR (b4)	18	dd	5
								DIR (b5)	1A	dd	5
								DIR (b6)	1C	dd	5
								DIR (b7)	1E	dd	5

Table 14-6. Instruction Set Summary (Sheet 3 of 6)

Source Form	Operation	Description	Effect on CCR					Address Mode	Opcode	Operand	Cycles
			H	I	N	Z	C				
BSR <i>rel</i>	Branch to Subroutine	PC ← (PC) + 2; push (PCL) SP ← (SP) - 1; push (PCH) SP ← (SP) - 1 PC ← (PC) + <i>rel</i>	—	—	—	—	—	REL	AD	rr	6
CLC	Clear Carry Bit	C ← 0	—	—	—	—	0	INH	98		2
CLI	Clear Interrupt Mask	I ← 0	—	0	—	—	—	INH	9A		2
CLR <i>opr</i> CLRA CLR X CLR <i>opr,X</i> CLR ,X	Clear Byte	M ← \$00 A ← \$00 X ← \$00 M ← \$00 M ← \$00	—	—	0	1	—	DIR INH INH IX1 IX	3F 4F 5F 6F 7F	dd  ff	5 3 3 6 5
CMP # <i>opr</i> CMP <i>opr</i> CMP <i>opr</i> CMP <i>opr,X</i> CMP <i>opr,X</i> CMP ,X	Compare Accumulator with Memory Byte	(A) - (M)	—	—	↑	↑	↑	IMM DIR EXT IX2 IX1 IX	A1 B1 C1 D1 E1 F1	ii dd hh ll ee ff ff	2 3 4 5 4 3
COM <i>opr</i> COMA COM X COM <i>opr,X</i> COM ,X	Complement Byte (One's Complement)	M ← (M) = \$FF - (M) A ← (A) = \$FF - (M) X ← (X) = \$FF - (M) M ← (M) = \$FF - (M) M ← (M) = \$FF - (M)	—	—	↑	↑	1	DIR INH INH IX1 IX	33 43 53 63 73	dd  ff	5 3 3 6 5
CPX # <i>opr</i> CPX <i>opr</i> CPX <i>opr</i> CPX <i>opr,X</i> CPX <i>opr,X</i> CPX ,X	Compare Index Register with Memory Byte	(X) - (M)	—	—	↑	↑	1	IMM DIR EXT IX2 IX1 IX	A3 B3 C3 D3 E3 F3	ii dd hh ll ee ff ff	2 3 4 5 4 3
DEC <i>opr</i> DECA DEC X DEC <i>opr,X</i> DEC ,X	Decrement Byte	M ← (M) - 1 A ← (A) - 1 X ← (X) - 1 M ← (M) - 1 M ← (M) - 1	—	—	↑	↑	—	DIR INH INH IX1 IX	3A 4A 5A 6A 7A	dd  ff	5 3 3 6 5
EOR # <i>opr</i> EOR <i>opr</i> EOR <i>opr</i> EOR <i>opr,X</i> EOR <i>opr,X</i> EOR ,X	EXCLUSIVE OR Accumulator with Memory Byte	A ← (A) ⊕ (M)	—	—	↑	↑	—	IMM DIR EXT IX2 IX1 IX	A8 B8 C8 D8 E8 F8	ii dd hh ll ee ff ff	2 3 4 5 4 3
INC <i>opr</i> INCA INC X INC <i>opr,X</i> INC ,X	Increment Byte	M ← (M) + 1 A ← (A) + 1 X ← (X) + 1 M ← (M) + 1 M ← (M) + 1	—	—	↑	↑	—	DIR INH INH IX1 IX	3C 4C 5C 6C 7C	dd  ff	5 3 3 6 5
JMP <i>opr</i> JMP <i>opr</i> JMP <i>opr,X</i> JMP <i>opr,X</i> JMP ,X	Unconditional Jump	PC ← Jump Address	—	—	—	—	—	DIR EXT IX2 IX1 IX	BC CC DC EC FC	dd hh ll ee ff ff	2 3 4 3 2

Table 14-6. Instruction Set Summary (Sheet 4 of 6)

Source Form	Operation	Description	Effect on CCR					Address Mode	Opcode	Operand	Cycles
			H	I	N	Z	C				
JSR <i>opr</i> JSR <i>opr</i> JSR <i>opr,X</i> JSR <i>opr,X</i> JSR ,X	Jump to Subroutine	PC ← (PC) + n (n = 1, 2, or 3) Push (PCL); SP ← (SP) – 1 Push (PCH); SP ← (SP) – 1 PC ← Conditional Address	—	—	—	—	—	DIR EXT IX2 IX1 IX	BD CD DD ED FD	dd hh ll ee ff ff	5 6 7 6 5
LDA # <i>opr</i> LDA <i>opr</i> LDA <i>opr</i> LDA <i>opr,X</i> LDA <i>opr,X</i> LDA ,X	Load Accumulator with Memory Byte	A ← (M)	—	—	†	†	—	IMM DIR EXT IX2 IX1 IX	A6 B6 C6 D6 E6 F6	ii dd hh ll ee ff ff	2 3 4 5 4 3
LDX # <i>opr</i> LDX <i>opr</i> LDX <i>opr</i> LDX <i>opr,X</i> LDX <i>opr,X</i> LDX ,X	Load Index Register with Memory Byte	X ← (M)	—	—	†	†	—	IMM DIR EXT IX2 IX1 IX	AE BE CE DE EE FE	ii dd hh ll ee ff ff	2 3 4 5 4 3
LSL <i>opr</i> LSLA LSLX LSL <i>opr,X</i> LSL ,X	Logical Shift Left (Same as ASL)		—	—	†	†	—	DIR INH INH IX1 IX	38 48 58 68 78	dd	5 3 3 6 5
LSR <i>opr</i> LSRA LSRX LSR <i>opr,X</i> LSR ,X	Logical Shift Right		—	—	0	†	†	DIR INH INH IX1 IX	34 44 54 64 74	dd	5 3 3 6 5
MUL	Unsigned Multiply	X : A ← (X) × (A)	0	—	—	—	0	INH	42		11
NEG <i>opr</i> NEGA NEGX NEG <i>opr,X</i> NEG ,X	Negate Byte (Two's Complement)	M ← –(M) = \$00 – (M) A ← –(A) = \$00 – (A) X ← –(X) = \$00 – (X) M ← –(M) = \$00 – (M) M ← –(M) = \$00 – (M)	—	—	†	†	†	DIR INH INH IX1 IX	30 40 50 60 70	ii ff	5 3 3 6 5
NOP	No Operation		—	—	—	—	—	INH	9D		2
ORA # <i>opr</i> ORA <i>opr</i> ORA <i>opr</i> ORA <i>opr,X</i> ORA <i>opr,X</i> ORA ,X	Logical OR Accumulator with Memory	A ← (A) ∨ (M)	—	—	†	†	—	IMM DIR EXT IX2 IX1 IX	AA BA CA DA EA FA	ii dd hh ll ee ff ff	2 3 4 5 4 3
ROL <i>opr</i> ROLA ROLX ROL <i>opr,X</i> ROL ,X	Rotate Byte Left through Carry Bit		—	—	†	†	†	DIR INH INH IX1 IX	39 49 59 69 79	dd	5 3 3 6 5

Table 14-6. Instruction Set Summary (Sheet 5 of 6)

Source Form	Operation	Description	Effect on CCR					Address Mode	Opcode	Operand	Cycles
			H	I	N	Z	C				
ROR <i>opr</i> RORA RORX ROR <i>opr,X</i> ROR ,X	Rotate Byte Right through Carry Bit		—	—	†	†	†	DIR INH INH IX1 IX	36 46 56 66 76	dd  ff	5 3 3 6 5
RSP	Reset Stack Pointer	SP ← \$00FF	—	—	—	—	—	INH	9C		2
RTI	Return from Interrupt	SP ← (SP) + 1; Pull (CCR) SP ← (SP) + 1; Pull (A) SP ← (SP) + 1; Pull (X) SP ← (SP) + 1; Pull (PCH) SP ← (SP) + 1; Pull (PCL)	†	†	†	†	†	INH	80		6
RTS	Return from Subroutine	SP ← (SP) + 1; Pull (PCH) SP ← (SP) + 1; Pull (PCL)						INH			
SBC # <i>opr</i> SBC <i>opr</i> SBC <i>opr</i> SBC <i>opr,X</i> SBC <i>opr,X</i> SBC ,X	Subtract Memory Byte and Carry Bit from Accumulator	A ← (A) – (M) – (C)	—	—	†	†	†	IMM DIR EXT IX2 IX1 IX	A2 B2 C2 D2 E2 F2	ii dd hh ll ee ff ff	2 3 4 5 4 3
SEC	Set Carry Bit	C ← 1	—	—	—	—	1	INH	99		2
SEI	Set Interrupt Mask	I ← 1	—	1	—	—	—	INH	9B		2
STA <i>opr</i> STA <i>opr</i> STA <i>opr,X</i> STA <i>opr,X</i> STA ,X	Store Accumulator in Memory	M ← (A)	—	—	†	†	—	DIR EXT IX2 IX1 IX	B7 C7 D7 E7 F7	dd hh ll ee ff ff	4 5 6 5 4
STOP	Stop Oscillator and Enable IRQ Pin		—	0	—	—	—	INH	8E		2
STX <i>opr</i> STX <i>opr</i> STX <i>opr,X</i> STX <i>opr,X</i> STX ,X	Store Index Register In Memory	M ← (X)	—	—	†	†	—	DIR EXT IX2 IX1 IX	BF CF DF EF FF	dd hh ll ee ff ff	4 5 6 5 4
SUB # <i>opr</i> SUB <i>opr</i> SUB <i>opr</i> SUB <i>opr,X</i> SUB <i>opr,X</i> SUB ,X	Subtract Memory Byte from Accumulator	A ← (A) – (M)	—	—	†	†	†	IMM DIR EXT IX2 IX1 IX	A0 B0 C0 D0 E0 F0	ii dd hh ll ee ff ff	2 3 4 5 4 3
SWI	Software Interrupt	PC ← (PC) + 1; Push (PCL) SP ← (SP) – 1; Push (PCH) SP ← (SP) – 1; Push (X) SP ← (SP) – 1; Push (A) SP ← (SP) – 1; Push (CCR) SP ← (SP) – 1; I ← 1 PCH ← Interrupt Vector High Byte PCL ← Interrupt Vector Low Byte	—	1	—	—	—	INH	83		10

**Table 14-6. Instruction Set Summary (Sheet 6 of 6)**

Source Form	Operation	Description	Effect on CCR					Address Mode	Opcode	Operand	Cycles
			H	I	N	Z	C				
TAX	Transfer Accumulator to Index Register	$X \leftarrow (A)$	—	—	—	—	—	INH	97		2
TST <i>opr</i> TSTA TSTX TST <i>opr,X</i> TST ,X	Test Memory Byte for Negative or Zero	$(M) - \$00$	—	—	—	—	—	DIR INH INH IX1 IX	3D 4D 5D 6D 7D	dd  ff	4 3 3 5 4
TXA	Transfer Index Register to Accumulator	$A \leftarrow (X)$	—	—	—	—	—	INH	9F		2
WAIT	Stop CPU Clock and Enable Interrupts		—	↑	—	—	—	INH	8F		2

- A Accumulator
- C Carry/borrow flag
- CCR Condition code register
- dd Direct address of operand
- dd rr Direct address of operand and relative offset of branch instruction
- DIR Direct addressing mode
- ee ff High and low bytes of offset in indexed, 16-bit offset addressing
- EXT Extended addressing mode
- ff Offset byte in indexed, 8-bit offset addressing
- H Half-carry flag
- hh ll High and low bytes of operand address in extended addressing
- I Interrupt mask
- ii Immediate operand byte
- IMM Immediate addressing mode
- INH Inherent addressing mode
- IX Indexed, no offset addressing mode
- IX1 Indexed, 8-bit offset addressing mode
- IX2 Indexed, 16-bit offset addressing mode
- M Memory location
- N Negative flag
- n Any bit

- opr* Operand (one or two bytes)
- PC Program counter
- PCH Program counter high byte
- PCL Program counter low byte
- REL Relative addressing mode
- rel* Relative program counter offset byte
- rr Relative program counter offset byte
- SP Stack pointer
- X Index register
- Z Zero flag
- # Immediate value
- ^ Logical AND
- ∨ Logical OR
- ⊕ Logical EXCLUSIVE OR
- ( ) Contents of
- ( ) Negation (two's complement)
- ← Loaded with
- ? If
- :
- ↑ Set or cleared
- Not affected

## 14.5 Opcode Map

See [Table 14-7](#).

Table 14-7. Opcode Map

MSB LSB	Bit Manipulation			Branch			Read-Modify-Write					Control			Register/Mem								
	DIR	DIR	REL	DIR	INH	INH	IX1	IX	INH	INH	INH	IX1	IX	INH	INH	IMM	DIR	EXT	DIR	B	C	D	
0	5 DIR2	5 DIR2	3 REL2	5 DIR1	3 INH1	3 INH1	6 IX11	5 NEG IX1	3 NEGX INH2	3 NEG INH2	5 IX1	7	5 NEG IX1	9 RTI INH	2 IMM2	2 SUB DIR3	3 SUB DIR3	4 SUB EXT3	2 IMM2	2 SUB DIR3	3 SUB DIR3	4 SUB EXT3	4 SUB EXT3
1	5 DIR2	5 DIR2	3 REL	5 DIR1	3 INH1	3 INH1	6 IX11	5 NEG IX1	3 NEGX INH2	3 NEG INH2	5 IX1	7	5 NEG IX1	9 RTI INH	2 IMM2	2 SUB DIR3	3 SUB DIR3	4 SUB EXT3	2 IMM2	2 SUB DIR3	3 SUB DIR3	4 SUB EXT3	4 SUB EXT3
2	5 DIR2	5 DIR2	3 REL	5 DIR1	3 INH1	3 INH1	6 IX11	5 NEG IX1	3 NEGX INH2	3 NEG INH2	5 IX1	7	5 NEG IX1	9 RTI INH	2 IMM2	2 SUB DIR3	3 SUB DIR3	4 SUB EXT3	2 IMM2	2 SUB DIR3	3 SUB DIR3	4 SUB EXT3	4 SUB EXT3
3	5 DIR2	5 DIR2	3 REL2	5 DIR1	3 INH1	3 INH1	6 IX11	5 NEG IX1	3 NEGX INH2	3 NEG INH2	5 IX1	7	5 NEG IX1	9 RTI INH	2 IMM2	2 SUB DIR3	3 SUB DIR3	4 SUB EXT3	2 IMM2	2 SUB DIR3	3 SUB DIR3	4 SUB EXT3	4 SUB EXT3
4	5 DIR2	5 DIR2	3 REL2	5 DIR1	3 INH1	3 INH1	6 IX11	5 NEG IX1	3 NEGX INH2	3 NEG INH2	5 IX1	7	5 NEG IX1	9 RTI INH	2 IMM2	2 SUB DIR3	3 SUB DIR3	4 SUB EXT3	2 IMM2	2 SUB DIR3	3 SUB DIR3	4 SUB EXT3	4 SUB EXT3
5	5 DIR2	5 DIR2	3 REL	5 DIR1	3 INH1	3 INH1	6 IX11	5 NEG IX1	3 NEGX INH2	3 NEG INH2	5 IX1	7	5 NEG IX1	9 RTI INH	2 IMM2	2 SUB DIR3	3 SUB DIR3	4 SUB EXT3	2 IMM2	2 SUB DIR3	3 SUB DIR3	4 SUB EXT3	4 SUB EXT3
6	5 DIR2	5 DIR2	3 REL2	5 DIR1	3 INH1	3 INH1	6 IX11	5 NEG IX1	3 NEGX INH2	3 NEG INH2	5 IX1	7	5 NEG IX1	9 RTI INH	2 IMM2	2 SUB DIR3	3 SUB DIR3	4 SUB EXT3	2 IMM2	2 SUB DIR3	3 SUB DIR3	4 SUB EXT3	4 SUB EXT3
7	5 DIR2	5 DIR2	3 REL2	5 DIR1	3 INH1	3 INH1	6 IX11	5 NEG IX1	3 NEGX INH2	3 NEG INH2	5 IX1	7	5 NEG IX1	9 RTI INH	2 IMM2	2 SUB DIR3	3 SUB DIR3	4 SUB EXT3	2 IMM2	2 SUB DIR3	3 SUB DIR3	4 SUB EXT3	4 SUB EXT3
8	5 DIR2	5 DIR2	3 REL2	5 DIR1	3 INH1	3 INH1	6 IX11	5 NEG IX1	3 NEGX INH2	3 NEG INH2	5 IX1	7	5 NEG IX1	9 RTI INH	2 IMM2	2 SUB DIR3	3 SUB DIR3	4 SUB EXT3	2 IMM2	2 SUB DIR3	3 SUB DIR3	4 SUB EXT3	4 SUB EXT3
9	5 DIR2	5 DIR2	3 REL2	5 DIR1	3 INH1	3 INH1	6 IX11	5 NEG IX1	3 NEGX INH2	3 NEG INH2	5 IX1	7	5 NEG IX1	9 RTI INH	2 IMM2	2 SUB DIR3	3 SUB DIR3	4 SUB EXT3	2 IMM2	2 SUB DIR3	3 SUB DIR3	4 SUB EXT3	4 SUB EXT3
A	5 DIR2	5 DIR2	3 REL2	5 DIR1	3 INH1	3 INH1	6 IX11	5 NEG IX1	3 NEGX INH2	3 NEG INH2	5 IX1	7	5 NEG IX1	9 RTI INH	2 IMM2	2 SUB DIR3	3 SUB DIR3	4 SUB EXT3	2 IMM2	2 SUB DIR3	3 SUB DIR3	4 SUB EXT3	4 SUB EXT3
B	5 DIR2	5 DIR2	3 REL	5 DIR1	3 INH1	3 INH1	6 IX11	5 NEG IX1	3 NEGX INH2	3 NEG INH2	5 IX1	7	5 NEG IX1	9 RTI INH	2 IMM2	2 SUB DIR3	3 SUB DIR3	4 SUB EXT3	2 IMM2	2 SUB DIR3	3 SUB DIR3	4 SUB EXT3	4 SUB EXT3
C	5 DIR2	5 DIR2	3 REL2	5 DIR1	3 INH1	3 INH1	6 IX11	5 NEG IX1	3 NEGX INH2	3 NEG INH2	5 IX1	7	5 NEG IX1	9 RTI INH	2 IMM2	2 SUB DIR3	3 SUB DIR3	4 SUB EXT3	2 IMM2	2 SUB DIR3	3 SUB DIR3	4 SUB EXT3	4 SUB EXT3
D	5 DIR2	5 DIR2	3 REL2	5 DIR1	3 INH1	3 INH1	6 IX11	5 NEG IX1	3 NEGX INH2	3 NEG INH2	5 IX1	7	5 NEG IX1	9 RTI INH	2 IMM2	2 SUB DIR3	3 SUB DIR3	4 SUB EXT3	2 IMM2	2 SUB DIR3	3 SUB DIR3	4 SUB EXT3	4 SUB EXT3
E	5 DIR2	5 DIR2	3 REL	5 DIR1	3 INH1	3 INH1	6 IX11	5 NEG IX1	3 NEGX INH2	3 NEG INH2	5 IX1	7	5 NEG IX1	9 RTI INH	2 IMM2	2 SUB DIR3	3 SUB DIR3	4 SUB EXT3	2 IMM2	2 SUB DIR3	3 SUB DIR3	4 SUB EXT3	4 SUB EXT3
F	5 DIR2	5 DIR2	3 REL2	5 DIR1	3 INH1	3 INH1	6 IX11	5 NEG IX1	3 NEGX INH2	3 NEG INH2	5 IX1	7	5 NEG IX1	9 RTI INH	2 IMM2	2 SUB DIR3	3 SUB DIR3	4 SUB EXT3	2 IMM2	2 SUB DIR3	3 SUB DIR3	4 SUB EXT3	4 SUB EXT3

INH = Inherent  
 IMM = Immediate  
 DIR = Direct  
 EXT = Extended

REL = Relative  
 IX = Indexed, No Offset  
 IX1 = Indexed, 8-Bit Offset  
 IX2 = Indexed, 16-Bit Offset

MSB	0
LSB	0

MSB of Opcode

LSB of Opcode in Hexadecimal

Number of Cycles  
 Opcode Minemom  
 Number of Bytes/



# Chapter 15

## Electrical Specifications

### 15.1 Introduction

This section contains the electrical and timing specifications.

### 15.2 Maximum Ratings

Maximum ratings are the extreme limits to which the MCU can be exposed without permanently damaging it.

The MCU contains circuitry to protect the inputs against damage from high static voltages; however, do not apply voltages higher than those shown in the table below. Keep  $V_{In}$  and  $V_{Out}$  within the range  $V_{SS} \leq (V_{In} \text{ or } V_{Out}) \leq V_{DD}$ . Connect unused inputs to the appropriate voltage level, either  $V_{SS}$  or  $V_{DD}$ .

Rating	Symbol	Value	Unit
Supply voltage	$V_{DD}$	-0.3 to +7.0	V
Bootloader/self-check mode ( $\overline{IRQ}/V_{PP}$ pin only)	$V_{In}$	$V_{SS}$ -0.3 to 17	V
Current drain per pin excluding $V_{DD}$ and $V_{SS}$	I	25	mA
Operating junction temperature	$T_J$	+150	°C
Storage temperature range	$T_{stg}$	-65 to +150	°C

#### NOTE

*This device is not guaranteed to operate properly at the maximum ratings. Refer to [15.7 DC Electrical Characteristics \(5.0 Vdc\)](#) and [15.8 DC Electrical Characteristics \(3.0 Vdc\)](#) for guaranteed operating conditions.*

### 15.3 Operating Temperature Range

Characteristic	Symbol	Value	Unit
Operating temperature range Extended	$T_A$	$T_L$ to $T_H$ -40 to +85	°C

### 15.4 Thermal Characteristics

Characteristic	Symbol	Value	Unit
Thermal resistance Plastic DIP SOIC	$\theta_{JA}$	60	°C/W

## 15.5 Supply Current Characteristics ( $V_{DD} = 4.5$ to $5.5$ Vdc)

Characteristic <sup>(1)</sup>	Symbol	Min	Typ <sup>(2)</sup>	Max	Unit
<b>RUN<sup>(3)</sup></b> (analog and LVR disabled) Internal low-power oscillator at 100 kHz Internal low-power oscillator at 500 kHz External oscillator running at 4.2 MHz	$I_{DD}$	—	150 375 3.00	568 1100 5.20	$\mu$ A $\mu$ A mA
<b>WAIT<sup>(4)</sup></b> (analog and LVR disabled) Internal low-power oscillator at 100 kHz Internal low-power oscillator at 500 kHz External oscillator running at 4.2 MHz	$I_{DD}$	—	45 75 1.00	85 375 2.20	$\mu$ A $\mu$ A mA
<b>STOP<sup>(5)</sup></b> (analog and LVR disabled) Typical –40°C to 85°C	$I_{DD}$	—	2 4	10 20	$\mu$ A
<b>Incremental <math>I_{DD}</math> for enabled modules</b> LVR Analog subsystem	$I_{DD}$	—	5 380	15 475	$\mu$ A

- $V_{DD} = 4.5$  to  $5.5$  Vdc,  $V_{SS} = 0$  V,  $T_L \leq T_A \leq T_H$ , unless otherwise noted. All values shown reflect average measurements.
- Typical values at midpoint of voltage range, 25°C only
- Run (Operating)  $I_{DD}$ , Wait  $I_{DD}$ : Measured using external square wave clock source to OSC1 pin or internal oscillator, all inputs 0.2 Vdc from either supply rail ( $V_{DD}$  or  $V_{SS}$ ); no dc loads, less than 50 pF on all outputs,  $C_L = 20$  pF on OSC2.
- Wait  $I_{DD}$  is affected linearly by the OSC2 capacitance.
- Stop  $I_{DD}$ : All ports configured as inputs,  $V_{IL} = 0.2$  Vdc,  $V_{IH} = V_{DD} - 0.2$  Vdc, OSC1 =  $V_{DD}$ .

## 15.6 Supply Current Characteristics ( $V_{DD} = 2.7$ to $3.3$ Vdc)

Characteristic <sup>(1)</sup>	Symbol	Min	Typ <sup>(2)</sup>	Max	Unit
<b>RUN<sup>(3)</sup></b> (analog and LVR disabled) Internal low-power oscillator at 100 kHz Internal low-power oscillator at 500 kHz External oscillator running at 2.1 MHz	$I_{DD}$	—	70 320 1.25	320 800 2.60	$\mu$ A $\mu$ A mA
<b>WAIT<sup>(4)</sup></b> (analog and LVR disabled) Internal low-power oscillator at 100 kHz Internal low-power oscillator at 500 kHz External oscillator running at 2.1 MHz	$I_{DD}$	—	20 40 0.50	65 250 1.10	$\mu$ A $\mu$ A mA
<b>STOP<sup>(5)</sup></b> (analog and LVR disabled) 25°C –40°C to 85°C	$I_{DD}$	—	1 2	5 10	$\mu$ A
<b>Incremental <math>I_{DD}</math> for enabled modules</b> LVR Analog subsystem	$I_{DD}$	—	5 380	15 475	$\mu$ A

- $V_{DD} = 2.7$  to  $3.3$  Vdc,  $V_{SS} = 0$  V,  $T_L \leq T_A \leq T_H$ , unless otherwise noted. All values shown reflect average measurements.
- Typical values at midpoint of voltage range, 25°C only.
- Run (Operating)  $I_{DD}$ , Wait  $I_{DD}$ : Measured using external square wave clock source to OSC1 pin or internal oscillator, all inputs 0.2 Vdc from either supply rail ( $V_{DD}$  or  $V_{SS}$ ); no dc loads, less than 50 pF on all outputs,  $C_L = 20$  pF on OSC2.
- Wait  $I_{DD}$  is affected linearly by the OSC2 capacitance.
- Stop  $I_{DD}$ : All ports configured as inputs,  $V_{IL} = 0.2$  Vdc,  $V_{IH} = V_{DD} - 0.2$  Vdc, OSC1 =  $V_{DD}$ .

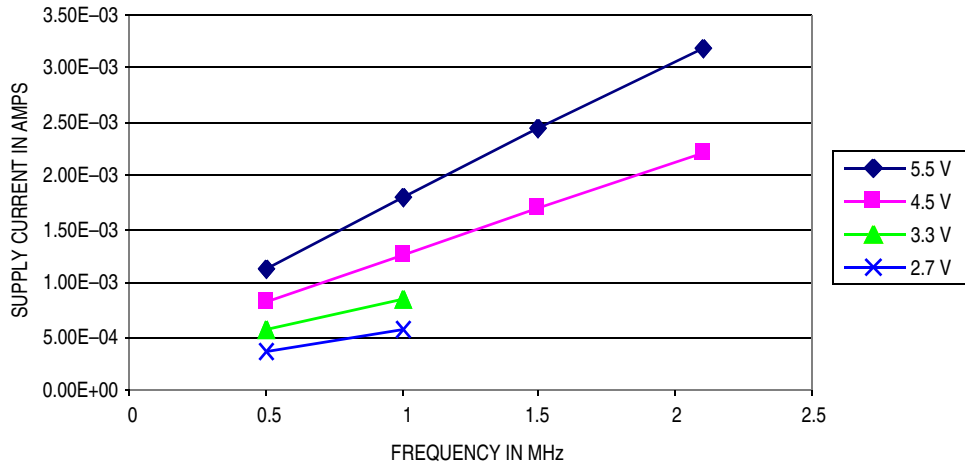

Figure 15-1. Typical Run  $I_{DD}$  versus Internal Clock Frequency at 25°C

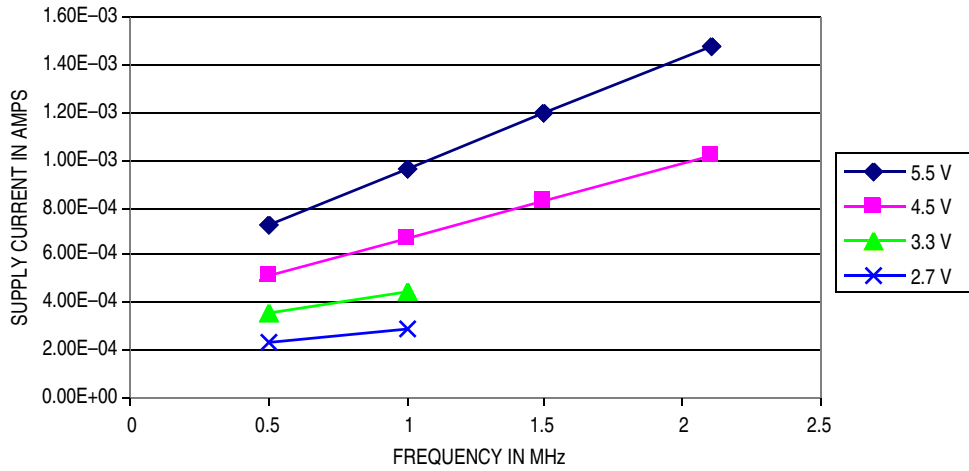

Figure 15-2. Typical Wait  $I_{DD}$  versus Internal Clock Frequency at 25°C

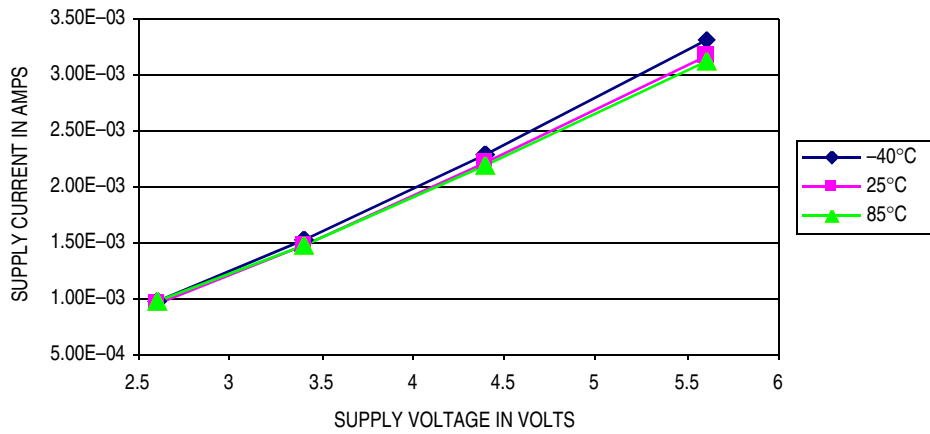
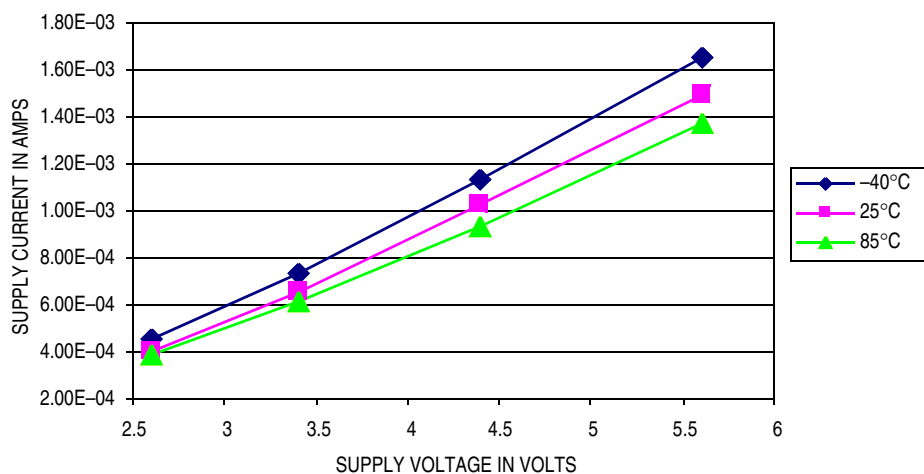
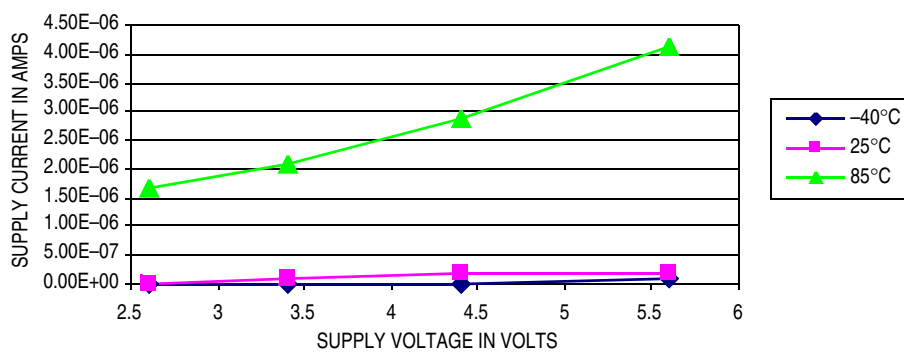

Figure 15-3. Typical Run  $I_{DD}$  with External Oscillator

## Electrical Specifications



**Figure 15-4. Typical Wait  $I_{DD}$  with External Oscillator**



**Figure 15-5. Typical Stop  $I_{DD}$  with Analog and LVR Disabled**

## 15.7 DC Electrical Characteristics (5.0 Vdc)

Characteristic <sup>(1), (2)</sup>	Symbol	Min	Typ <sup>(3)</sup>	Max	Unit
Output voltage $I_{Load} = 10.0 \mu A$ $I_{Load} = -10.0 \mu A$	$V_{OL}$ $V_{OH}$	— $V_{DD} - 0.1$	— —	0.1 —	V
Output high voltage ( $I_{Load} = -0.8 \text{ mA}$ ) PB0–PB7 ( $I_{Load} = -4.0 \text{ mA}$ ) PA0–PA5, PB4, PC0–PC7 <sup>(4)</sup>	$V_{OH}$	$V_{DD} - 0.8$ $V_{DD} - 0.8$	— —	— —	V
Output low voltage ( $I_{Load} = 1.6 \text{ mA}$ ) PB0–PB7, $\overline{RESET}$ ( $I_{Load} = 10 \text{ mA}$ ) PA0–PA5, PB4, PC0–PC7 <sup>(4)</sup> ( $I_{Load} = 15 \text{ mA}$ ) PA0–PA5, PB4, PC0–PC7 <sup>(4)</sup>	$V_{OL}$	— — —	— — —	0.4 0.4 1.5	V
High source current Total for all (6) PA0–PA5 pins and PB4 Total for all (8) PC0–PC7 <sup>(4)</sup> pins	$I_{OH}$	— —	— —	20 30	mA
High sink current Total for all (6) PA0–PA5 pins and PB4 Total for all (8) PC0–PC7 <sup>(4)</sup> pins	$I_{OL}$	— —	— —	40 60	mA
Input high voltage PA0–PA5, PB0–PB7, PC0–PC7 <sup>(4)</sup> , $\overline{RESET}$ , OSC1, $\overline{IRQ}/V_{PP}$	$V_{IH}$	$0.7 \times V_{DD}$	—	$V_{DD}$	V
Input low voltage PA0–PA5, PB0–PB7, PC0–PC7 <sup>(4)</sup> , $\overline{RESET}$ , OSC1, $\overline{IRQ}/V_{PP}$	$V_{IL}$	$V_{SS}$	—	$0.3 \times V_{DD}$	V
Input current OSC1, $\overline{IRQ}/V_{PP}$	$I_{In}$	-1	—	1	$\mu A$
Input current $\overline{RESET}$ (pullup, source) $\overline{RESET}$ (pulldown, sink)	$I_{In}$	10 -6	— —	— —	$\mu A$ mA
I/O ports hi-Z leakage current (pulldowns off) PA0–PA6, PB0–PB7, PC0–PC7 <sup>(4)</sup>	$I_{OZ}$	-2	—	2	$\mu A$
Input pulldown current PA0–PA5, PB0–PB7, PC0–PC7 <sup>(4)</sup> ( $V_{In}$ ; $V_{IH} = 0.7 \times V_{DD}$ ) PA0–PA5, PB0–PB7, PC0–PC7 <sup>(4)</sup> ( $V_{In}$ ; $V_{IL} = 0.3 \times V_{DD}$ )	$I_{IL}$	40 25	100 65	280 190	$\mu A$

1.  $+4.5 \leq V_{DD} \leq +5.5 \text{ V}$ ,  $V_{SS} = 0 \text{ V}$ ,  $T_L \leq T_A \leq T_H$ , unless otherwise noted
2. All values shown reflect average measurements.
3. Typical values at midpoint of voltage range, 25°C only.
4. PC0–PC7 parameters only apply to MC68HC705JP7.

## 15.8 DC Electrical Characteristics (3.0 Vdc)

Characteristic <sup>(1), (2)</sup>	Symbol	Min	Typ <sup>(3)</sup>	Max	Unit
Output voltage $I_{Load} = 10.0 \mu A$ $I_{Load} = -10.0 \mu A$	$V_{OL}$ $V_{OH}$	— $V_{DD} - 0.1$	— —	0.1 —	V
Output high voltage ( $I_{Load} = -0.2 \text{ mA}$ ) PB0–PB7 ( $I_{Load} = -2.0 \text{ mA}$ ) PA0–PA5, PB4, PC0–PC7 <sup>(4)</sup>	$V_{OH}$	$V_{DD} - 0.8$ $V_{DD} - 0.8$	— —	— —	V
Output low voltage ( $I_{Load} = 1.6 \text{ mA}$ ) PB0–PB7, $\overline{RESET}$ ( $I_{Load} = 5 \text{ mA}$ ) PA0–PA5, PB4, PC0–PC7 <sup>(4)</sup>	$V_{OL}$	— —	— —	0.3 0.3	V
High source current Total for all (6) PA0–PA5 pins and PB4 Total for all (8) PC0–PC7 <sup>(4)</sup> pins	$I_{OH}$	— —	— —	20 30	mA
High sink current Total for all (6) PA0–PA5 pins and PB4 Total for all (8) PC0–PC7 <sup>(4)</sup> pins	$I_{OL}$	— —	— —	40 60	mA
Input high voltage PA0–PA5, PB0–PB7, PC0–PC7 <sup>(4)</sup> , $\overline{RESET}$ , OSC1, $\overline{IRQ}/V_{PP}$	$V_{IH}$	$0.7 \times V_{DD}$	—	$V_{DD}$	V
Input low voltage PA0–PA5, PB0–PB7, PC0–PC7 <sup>(4)</sup> , $\overline{RESET}$ , OSC1, $\overline{IRQ}/V_{PP}$	$V_{IL}$	$V_{SS}$	—	$0.2 \times V_{DD}$	V
Input current OSC1, $\overline{IRQ}/V_{PP}$	$I_{in}$	-1	—	1	$\mu A$
Input current $\overline{RESET}$ (pullup, source) $\overline{RESET}$ (pulldown, sink)	$I_{in}$	5 -3	— —	— —	$\mu A$ mA
I/O ports hi-Z leakage current (pulldowns off) PA0–PA6, PB0–PB7, PC0–PC7 <sup>(4)</sup>	$I_{OZ}$	-2	—	2	$\mu A$
Input pulldown current PA0–PA5, PB0–PB7, PC0–PC7 <sup>(4)</sup> ( $V_{in}$ ; $V_{IH} = 0.7 \times V_{DD}$ ) PA0–PA5, PB0–PB7, PC0–PC7 <sup>(4)</sup> ( $V_{in}$ ; $V_{IL} = 0.3 \times V_{DD}$ )	$I_{IL}$	10 4	25 20	75 40	$\mu A$

1.  $+2.7 \leq V_{DD} \leq +3.3 \text{ V}$ ,  $V_{SS} = 0 \text{ V}$ ,  $T_L \leq T_A \leq T_H$ , unless otherwise noted
2. All values shown reflect average measurements.
3. Typical values at midpoint of voltage range, 25°C only.
4. PC0–PC7 parameters only apply to MC68HC705JP7.

## 15.9 Analog Subsystem Characteristics (5.0 Vdc)

**NOTE**  
See [Figure 15-6](#).

Characteristic <sup>(1)</sup>	Symbol	Min	Max	Unit
Voltage comparators				
Input offset voltage	$V_{IO}$	—	15	mV
Common-mode range	$V_{CMR}$	—	$V_{DD} - 1.5$	V
Comparator 1 input impedance	$Z_{In}$	800	—	k $\Omega$
Comparator 2 input impedance				
Direct input to comparator 2 (HOLD = 1, DHOLD = 0)	$Z_{In}$	800	—	k $\Omega$
Divider input to comparator 2 (HOLD = 0, DHOLD = 1)	$Z_{In}$	80	—	k $\Omega$
Input divider ratio (comparator 2, HOLD = 0, DHOLD = 1) $V_{In} = 0$ to $V_{DD} - 1.5$ V	$R_{DIV}$	0.49	0.51	
Analog subsystem internal $V_{SS}$ offset Sum of comparator offset and IR drop through $V_{SS}$	$V_{AOFF}$	20	40	mV
Channel selection multiplexer switch resistance	$R_{MUX}$	—	3	k $\Omega$
External current source (PB0/AN0)				
Source current ( $V_{Out} = V_{DD}/2$ )	$I_{CHG}$	85	113	$\mu$ A
Source current linearity ( $V_{Out} = 0$ to $V_{DD} - 1.5$ Vdc)	$I_{CHG}$	—	$\pm 1$	%FS
Discharge sink current ( $V_{Out} = 0.4$ V)	$I_{DIS}$	1.1	—	mA
External capacitor (connected to PB0/AN0)				
Voltage range	$V_{CAP}$	$V_{SS}$	$V_{DD} - 1.5$	V
Discharge time	$t_{DIS}$	5	10	ms/ $\mu$ F
Value of external ramping capacitor	$C_{EXT}$	—	2	$\mu$ F
Internal sample and hold capacitor				
Capacitance	$C_{SH}$	8	13	pF
Charge/discharge time (0 to 3.5 Vdc)				
Direct connection (HOLD = 1, DHOLD = 0)	$t_{SHCHG}$	1	—	$\mu$ s
Divided connection (HOLD = 0, DHOLD = 1)	$t_{SHDCHG}$	2	—	$\mu$ s
Temperature diode connection (HOLD = 1, DHOLD = 1)	$t_{SHTCHG}$	1	—	$\mu$ s
Leakage discharge rate	$C_{SHDIS}$	—	0.2	V/sec
Internal temperature sensing diode				
Voltage at $T_J = 25^\circ\text{C}$	$V_D$	0.65	0.71	V
Temperature change in voltage	$TC_D$	1.8	2.0	mV/ $^\circ\text{C}$

1.  $+4.5 \leq V_{DD} \leq +5.5$  V,  $V_{SS} = 0$  V,  $T_L \leq T_A \leq T_H$ , unless otherwise noted

### 15.10 Analog Subsystem Characteristics (3.0 Vdc)

**NOTE**  
See [Figure 15-6](#).

Characteristic <sup>(1)</sup>	Symbol	Min	Max	Unit
Voltage comparators				
Input offset voltage	$V_{IO}$	—	15	mV
Common-mode range	$V_{CMR}$	—	$V_{DD} - 1.5$	V
Comparator 1 input impedance	$Z_{in}$	800	—	k $\Omega$
Comparator 2 input impedance				
Direct input to comparator 2 (HOLD = 1, DHOLD = 0)	$Z_{in}$	800	—	k $\Omega$
Divider input to comparator 2 (HOLD = 0, DHOLD = 1)	$Z_{in}$	80	—	k $\Omega$
Input divider ratio (comparator 2, HOLD = 0, DHOLD = 1) $V_{in} = 0$ to $V_{DD} - 1.5$ V	$R_{DIV}$	0.49	0.51	
Analog subsystem internal $V_{SS}$ offset	$V_{AOFF}$	10	30	mV
Multiplexer switch resistance	$R_{MUX}$	—	5	k $\Omega$
External current source (PB0/AN0)				
Source current ( $V_{Out} = V_{DD}/2$ )	$I_{CHG}$	75	104	$\mu$ A
Source current linearity ( $V_{Out} = 0$ to $V_{DD} - 1.5$ Vdc)	$I_{CHG}$	—	$\pm 1$	%FS
Discharge sink current ( $V_{Out} = 0.4$ V)	$I_{DIS}$	1	—	mA
External capacitor (connected to PB0/AN0)				
Voltage range	$V_{CAP}$	$V_{SS}$	$V_{DD} - 1.5$	V
Discharge time	$t_{DIS}$	5	10	ms/ $\mu$ F
Value of external ramping capacitor	$C_{EXT}$	—	2	$\mu$ F
Internal sample and hold capacitor				
Capacitance	$C_{SH}$	8	13	pF
Charge/discharge time (0 to 3.5 Vdc)				
Direct connection (HOLD = 1, DHOLD = 0)	$t_{SHCHG}$	1	—	$\mu$ s
Divided connection (HOLD = 0, DHOLD = 1)	$t_{SHDCHG}$	2	—	$\mu$ s
Temperature diode connection (HOLD = 1, DHOLD = 1)	$t_{SHTCHG}$	1	—	$\mu$ s
Leakage discharge rate	$C_{SHDIS}$	—	0.1	V/sec
Internal temperature sensing diode				
Voltage at $T_J = 25^\circ\text{C}$	$V_D$	0.65	0.71	V
Temperature change in voltage	$TC_D$	1.8	2.0	mV/ $^\circ\text{C}$

1.  $+2.7 \leq V_{DD} \leq +3.3$  V,  $V_{SS} = 0$  V,  $T_L \leq T_A \leq T_H$ , unless otherwise noted

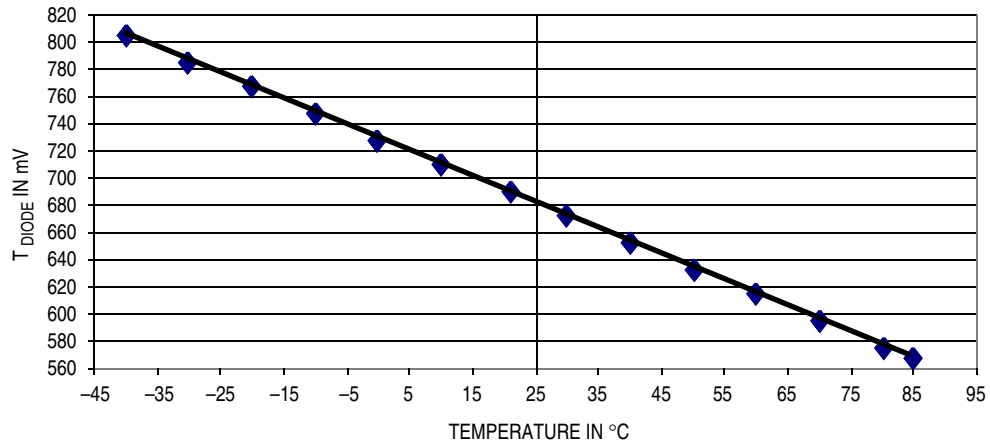

Figure 15-6. Typical Temperature Diode Performance

## 15.11 Control Timing (5.0 Vdc)

Characteristic <sup>(1)</sup>	Symbol	Min	Max	Unit
Frequency of oscillation (OSC)	$f_{OSC}$	—	4.2	MHz
RC oscillator option				
Crystal oscillator option				
External clock source		dc	4.2	MHz
Internal low-power oscillator		60	140	kHz
Standard product (100 kHz nominal)				
Mask option (500 kHz nominal, see Note 3)	300	700	kHz	
Internal operating frequency, crystal, or external clock ( $f_{OSC}/2$ )	$f_{OP}$	—	2.1	MHz
RC oscillator option				
Crystal oscillator option				
External clock source		dc	2.1	MHz
Internal low-power oscillator		30	75	kHz
Standard product (100 kHz nominal)				
Mask option (500 kHz nominal <sup>(2)</sup> )	150	350	kHz	
Cycle time ( $1/f_{OP}$ )	$t_{cyc}$	476	—	ns
External oscillator or clock source				
Internal low-power oscillator		14.29	33.33	$\mu$ s
Standard product (100 kHz nominal)				
Mask option (500 kHz nominal <sup>(2)</sup> )	2.86	6.67	$\mu$ s	
16-bit timer	$t_{RESL}$ $t_{TH}, t_{TL}$	4.0	—	$t_{cyc}$ ns
Resolution				
Input capture (TCAP) pulse width				
Interrupt pulse width low (edge-triggered)	$t_{LIH}$	284	—	ns
Interrupt pulse period	$t_{LIL}$	(3)	—	$t_{cyc}$
OSC1 pulse width (external clock input)	$t_{OH}, t_{OL}$	110	—	ns
Analog subsystem response	$t_{CPROP}$ $t_{CDELAY}$ $t_{ISTART}$ $t_{IDELAY}$ $t_{BDELAY}$	—	2	$\mu$ s
Voltage comparators				
Switching time (10 mV overdrive, either input)				
Comparator power-up delay (bias circuit already powered up)		—	2	$\mu$ s
External current source (PBO/ANO)		—	1	$\mu$ s
Switching time ( $I_{DIS}$ to $I_{RAMP}$ )				
Power-up delay (bias circuit already powered up)		—	2	$\mu$ s
Bias circuit power-up delay		—	2	$\mu$ s

1.  $V_{DD} = 4.5$  to  $5.5$  Vdc,  $V_{SS} = 0$  V,  $T_L \leq T_A \leq T_H$ , unless otherwise noted

2. The 500-kHz nominal mask option is available through special order only. Contact your local Freescale sales representative for detailed ordering information. Not offered with the RC oscillator.

3. The minimum period,  $t_{LIL}$ , should not be less than the number of cycle times it takes to execute the interrupt service routine plus  $21 t_{cyc}$ .

## 15.12 Control Timing (3.0 Vdc)

Characteristic <sup>(1)</sup>	Symbol	Min	Max	Unit				
Frequency of oscillation (OSC)	$f_{OSC}$	—	2.1	MHz				
RC oscillator option								
Crystal oscillator option								
External clock source		dc	2.1	MHz				
Internal low-power oscillator		60	140	kHz				
Standard product (100 kHz nominal)								
Mask option (500 kHz nominal, see Note 3))	300	700	kHz					
Internal operating frequency, crystal, or external clock ( $f_{OSC}/2$ )	$f_{OP}$	—	1.05	MHz				
RC oscillator option								
Crystal oscillator option								
External clock source		dc	1.05	MHz				
Internal low-power oscillator		30	70	kHz				
Standard product (100 kHz nominal)								
Mask option (500 kHz nominal <sup>(2)</sup> )	150	350	kHz					
Cycle time ( $1/f_{OP}$ )	$t_{cyc}$	952	—	ns				
External oscillator or clock source								
Internal low-power oscillator		14.29	33.33	$\mu$ s				
Standard product (100 kHz nominal)								
Mask option (500 kHz nominal <sup>(2)</sup> )	2.86	6.67	$\mu$ s					
16-bit timer	$t_{RESL}$	4.0	—	$t_{cyc}$				
Resolution								
Input capture (TCAP) pulse width	$t_{TH}, t_{TL}$	284	—	ns				
Interrupt pulse width low (edge-triggered)	$t_{LILH}$	284	—	ns				
Interrupt pulse period	$t_{LIL}$	(3)	—	$t_{cyc}$				
OSC1 pulse width (external clock input)	$t_{OH}, t_{OL}$	110	—	ns				
Analog subsystem response								
Voltage comparators								
Switching time (10 mV overdrive, either input)					$t_{CPROP}$	—	2	$\mu$ s
Comparator power-up delay (bias circuit already powered up)					$t_{CDELAY}$	—	2	$\mu$ s
External current source (PBO/ANO)								
Switching time ( $I_{DIS}$ to $I_{RAMP}$ )					$t_{ISTART}$	—	1	$\mu$ s
Power-up delay (bias circuit already powered up)					$t_{IDELAY}$	—	2	$\mu$ s
Bias circuit power-up delay					$t_{BDELAY}$	—	2	$\mu$ s

1.  $+2.7 \leq V_{DD} \leq +3.3$  V,  $V_{SS} = 0$  V,  $T_L \leq T_A \leq T_H$ , unless otherwise noted

2. The 500 kHz nominal mask option is available through special order only. Contact your local Freescale sales representative for detailed ordering information. Not offered with the RC oscillator option.

3. The minimum period,  $t_{LIL}$ , should not be less than the number of cycle times it takes to execute the interrupt service routine plus  $21 t_{cyc}$ .

## Electrical Specifications

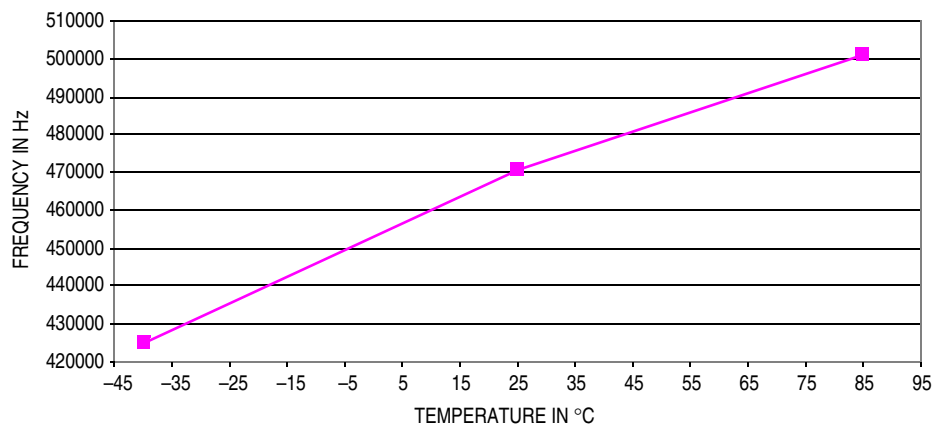

**Figure 15-7. Typical 500 kHz External Low-Power Oscillator Frequency**

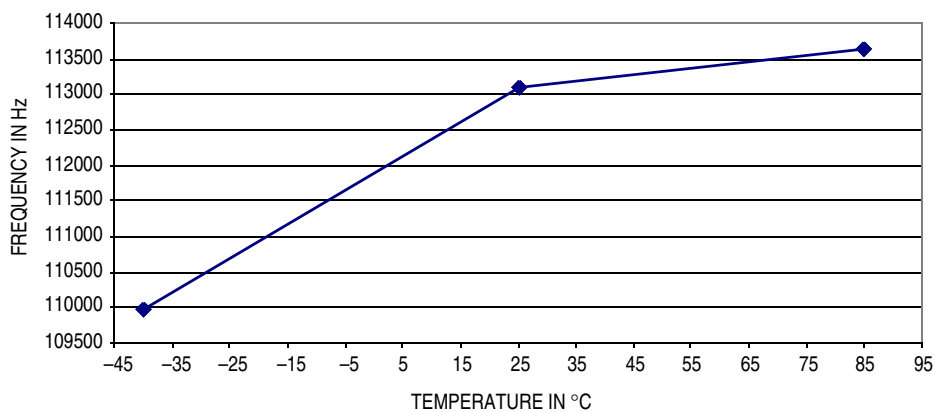

**Figure 15-8. Typical 100 kHz External Low-Power Oscillator Frequency**

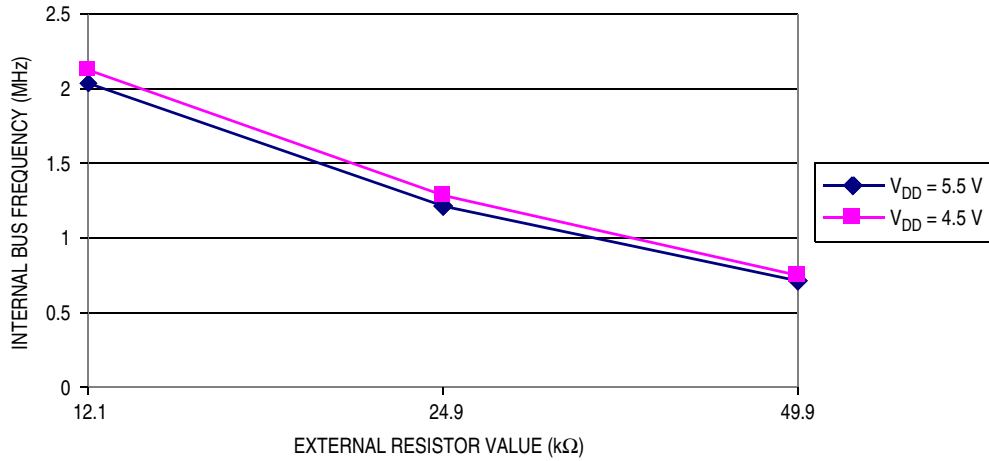

**Figure 15-9. Typical RC Oscillator Internal Operating Frequency Range versus Resistance for High V<sub>DD</sub> Operating Range at T = 25°C**

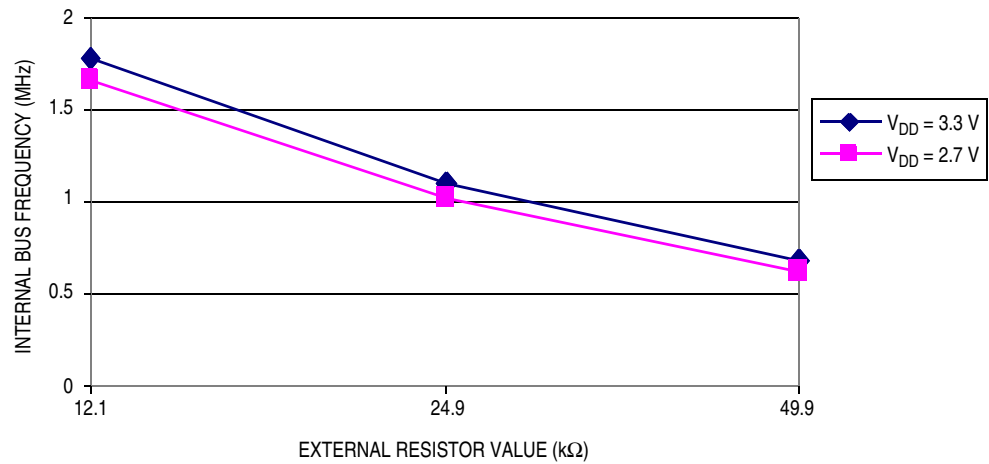

**Figure 15-10. Typical RC Oscillator Internal Operating Frequency Range versus Resistance for Low V<sub>DD</sub> Operating Range at T = 25°C**

### 15.13 PEPROM and EPROM Programming Characteristics

Characteristic <sup>(1)</sup>	Symbol	Min	Typ	Max	Unit
PEPROM programming voltage ( $\overline{IRQ}/V_{PP}$ )	$V_{PP}$	16.0	16.5	17.0	V
PEPROM programming voltage ( $\overline{IRQ}/V_{PP}$ )	$I_{PP}$	—	3.0	5.0	mA
PEPROM programming time per bit	$t_{EPGM}$	4.0	—	—	ms
EPROM/MOR programming voltage ( $\overline{IRQ}/V_{PP}$ )	$V_{PP}$	16.0	16.5	17.0	V
EPROM/MOR programming current ( $\overline{IRQ}/V_{PP}$ )	$I_{PP}$	—	3.0	5.0	mA
EPROM programming time per byte	$t_{EPGM}$	4.0	—	—	ms
MOR programming time	$t_{MPGM}$	10.0	—	—	ms

1.  $+4.5 \leq V_{DD} \leq +5.5$  V,  $V_{SS} = 0$  V,  $T_L \leq T_A \leq T_H$ , unless otherwise noted

**NOTE**

*To program the EPROM/OTPROM, MOR, or EPMSEC bits, the voltage on  $V_{DD}$  must be greater than 4.5 volts.*

## 15.14 SIOP Timing (V<sub>DD</sub> = 5.0 Vdc)

Characteristic <sup>(1)</sup>	Symbol	Min	Typ	Max	Unit
Frequency of operation Master Slave	f <sub>SIOP(M)</sub> f <sub>SIOP(S)</sub>	0.25 x f <sub>OP</sub> dc	0.25 x f <sub>OP</sub> —	0.25 x f <sub>OP</sub> 1050	kHz
Cycle time Master Slave	t <sub>SCK(M)</sub> t <sub>SCK(S)</sub>	4.0 x t <sub>cyc</sub> —	4.0 x t <sub>cyc</sub> —	4.0 x t <sub>cyc</sub> 3.8	μs
Clock (SCK) low time (f <sub>OP</sub> = 4.2 MHz)	t <sub>SCKL</sub>	952	—	—	ns
SDO data valid time	t <sub>v</sub>	—	—	200	ns
SDO hold time	t <sub>HO</sub>	0	—	—	ns
SDI setup time	t <sub>s</sub>	100	—	—	ns
SDI hold time	t <sub>H</sub>	100	—	—	ns

1. +4.5 ≤ V<sub>DD</sub> ≤ +5.5 V, V<sub>SS</sub> = 0 V, T<sub>L</sub> ≤ T<sub>A</sub> ≤ T<sub>H</sub>, unless otherwise noted

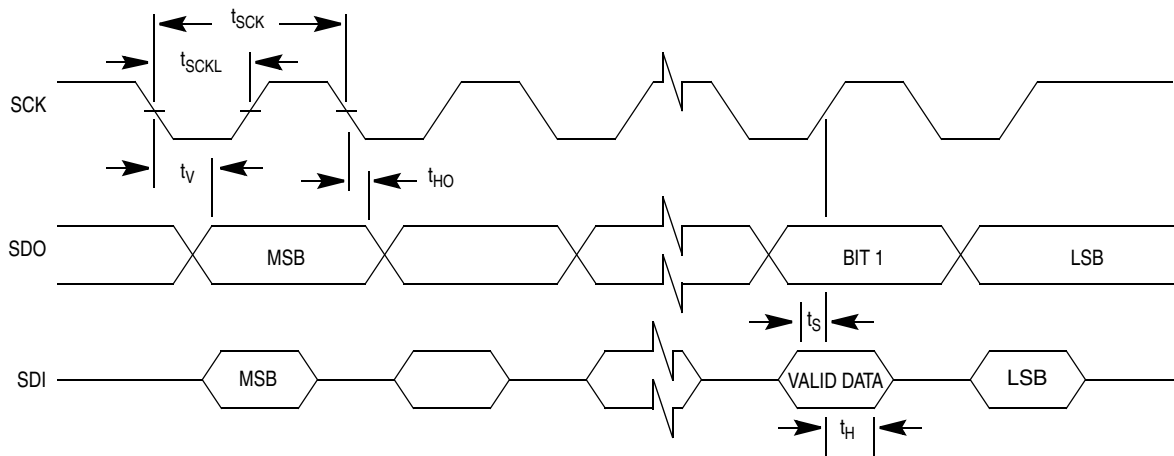

Figure 15-11. SIOP Timing Diagram

### 15.15 SIOP Timing ( $V_{DD} = 3.0$ Vdc)

Characteristic <sup>(1)</sup>	Symbol	Min	Typ	Max	Unit
Frequency of operation Master Slave	$f_{SIOP(M)}$ $f_{SIOP(S)}$	$0.25 \times f_{OP}$ dc	$0.25 \times f_{OP}$ —	$0.25 \times f_{OP}$ 525	kHz
Cycle time Master Slave	$t_{SCK(M)}$ $t_{SCK(S)}$	$4.0 \times t_{cyc}$ —	$4.0 \times t_{cyc}$ —	$4.0 \times t_{cyc}$ 1.9	$\mu$ s
Clock (SCK) low time ( $f_{OP} = 2.1$ MHz)	$t_{SCKL}$	1905	—	—	ns
SDO data valid time	$t_V$	—	—	400	ns
SDO hold time	$t_{HO}$	0	—	—	ns
SDI setup time	$t_S$	200	—	—	ns
SDI hold time	$t_H$	200	—	—	ns

1.  $+2.7 \leq V_{DD} \leq +3.3$  V,  $V_{SS} = 0$  V,  $T_L \leq T_A \leq T_H$ , unless otherwise noted

### 15.16 Reset Characteristics

Characteristic <sup>(1)</sup>	Symbol	Min	Typ	Max	Unit
Low-voltage reset Rising recovery voltage	$V_{LVRR}$	2.4	3.4	4.4	V
Falling reset voltage	$V_{LVRF}$	2.3	3.3	4.3	V
LVR hysteresis	$V_{LVRH}$	30	70	—	mV
POR recovery voltage <sup>(2)</sup>	$V_{POR}$	0	—	100	mV
POR $V_{DD}$ slew rate <sup>(2)</sup> Rising <sup>(2)</sup>	$S_{VDDR}$	—	—	0.1	V/ $\mu$ s
Falling <sup>(2)</sup>	$S_{VDDF}$	—	—	0.05	V/ $\mu$ s
$\overline{RESET}$ pulse width (when bus clock active)	$t_{RL}$	1.5	—	—	$t_{CYC}$
$\overline{RESET}$ pulldown pulse width from internal reset	$t_{RPD}$	3	—	4	$t_{CYC}$

1.  $+2.7 \leq V_{DD} \leq +3.3$  V,  $V_{SS} = 0$  V,  $T_L \leq T_A \leq T_H$ , unless otherwise noted  
 2. By design, not tested

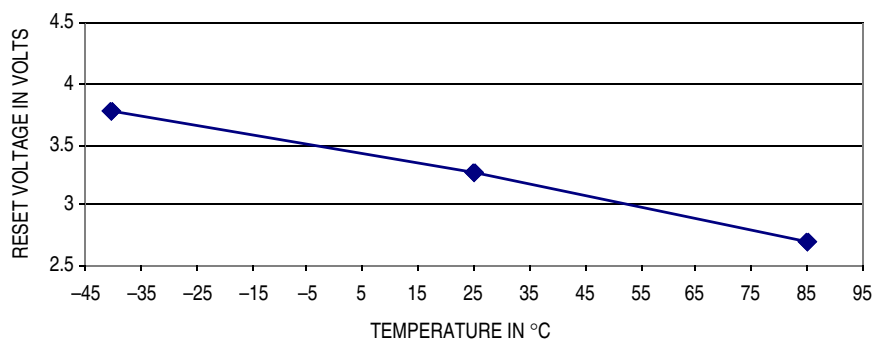
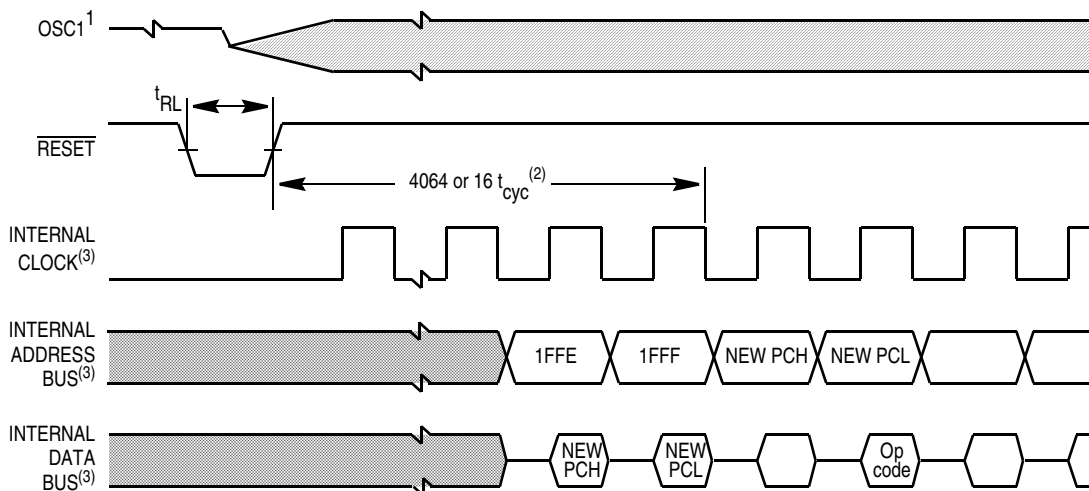
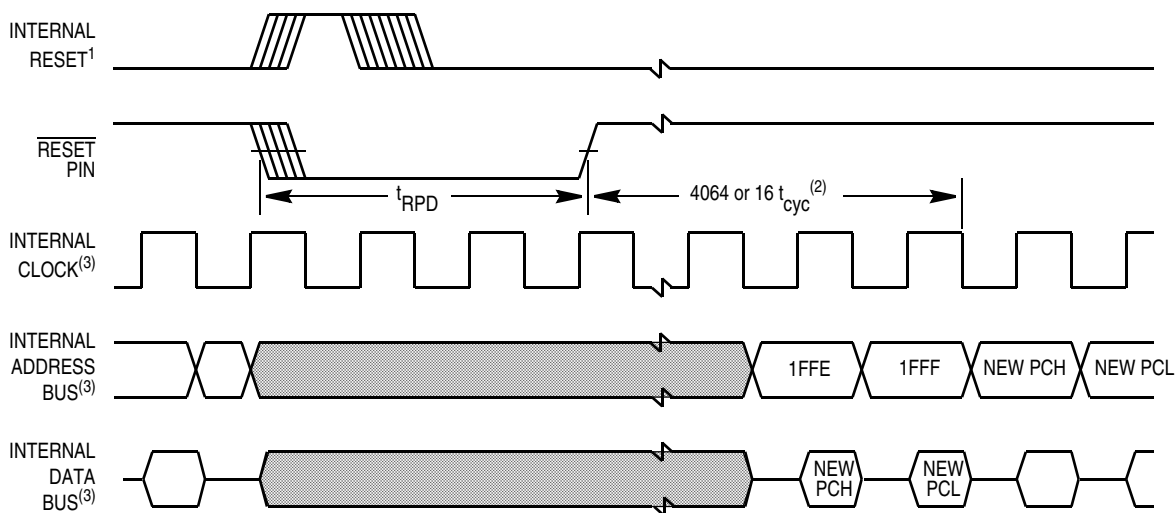

Figure 15-12. Typical Falling Low Voltage Reset



- Notes:
1. Represents the internal gating of the OSC1 pin
  2. Normal delay of 4064  $t_{cyc}$  or short delay option of 16  $t_{cyc}$
  3. Internal timing signal and data information not available externally

**Figure 15-13. Stop Recovery Timing Diagram**



- Notes:
1. Represents the internal reset from low-voltage reset, illegal opcode fetch or COP watchdog timeout
  2. Only if reset occurs during normal delay of 4064  $t_{cyc}$  or short delay option of 16  $t_{cyc}$  for initial power-up or stop recovery.
  3. Internal timing signal and data information not available externally

**Figure 15-14. Internal Reset Timing Diagram**

## Electrical Specifications

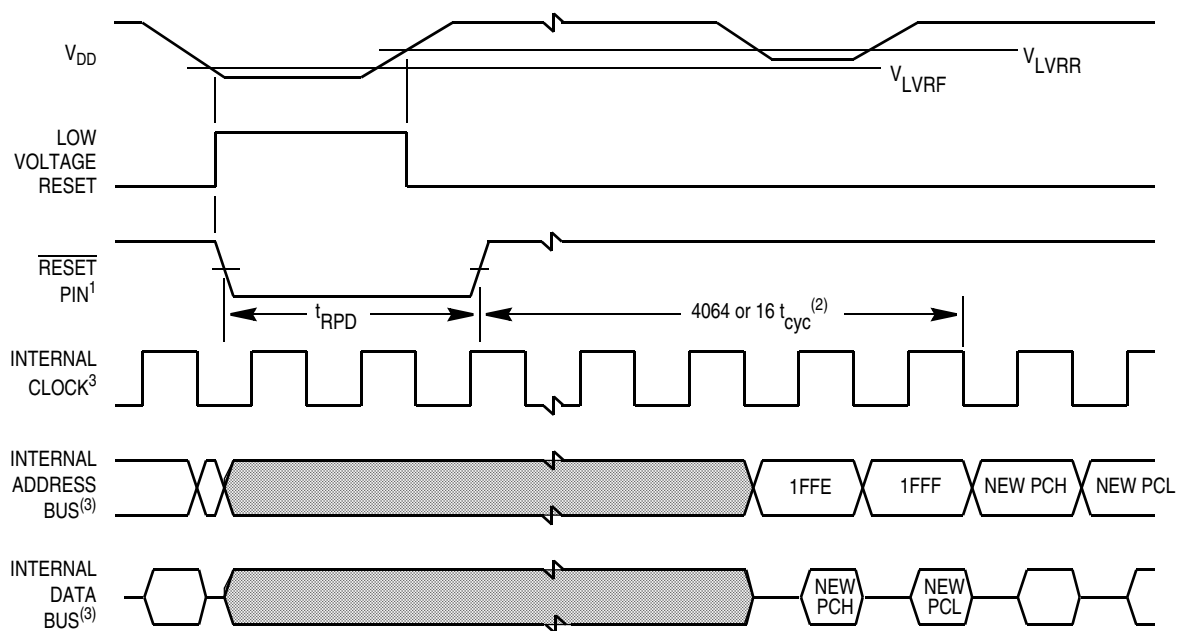

**Notes:**

1.  $\overline{\text{RESET}}$  pin pulled down by internal device
- 2 Only if LVR occurs during normal delay of  $4064 t_{cyc}$  or short delay option of  $16 t_{cyc}$  for initial power-up or stop recovery.
- 3 Internal timing signal and data information not available externally

**Figure 15-15. Low-Voltage Reset Timing Diagram**

# Chapter 16

## Mechanical Specifications

### 16.1 Introduction

The MC68HC705JJ7 is available in:

- 20-pin plastic dual in-line package (PDIP)
- 20-pin small outline integrated circuit (SOIC) package
- 20-pin windowed ceramic package

The MC68HC705JP7 is available in:

- 28-pin plastic dual in-line package (PDIP)
- 28-pin small outline integrated circuit (SOIC) package
- 28-pin windowed ceramic package

The following figures show the latest package drawings at the time of this publication. To make sure that you have the latest package specifications, contact your local Freescale Sales Office.

### 16.2 20-Pin Plastic Dual In-Line Package (Case 738)

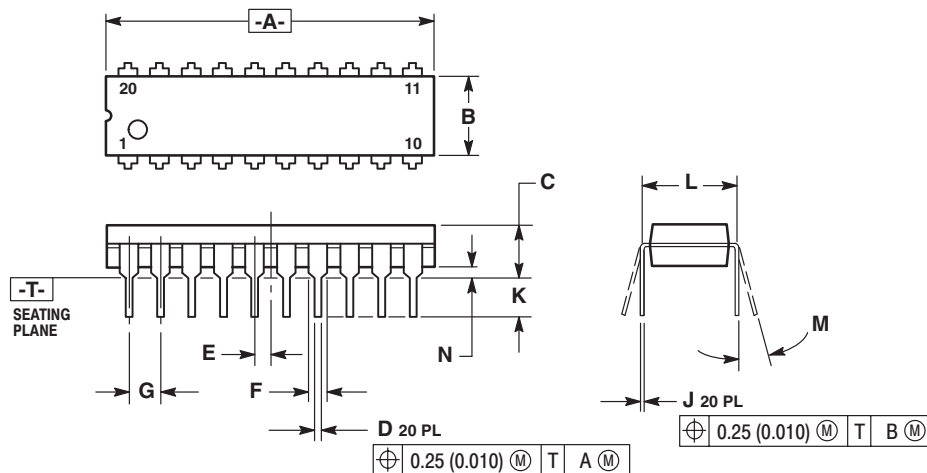

- NOTES:
1. DIMENSIONING AND TOLERANCING PER ANSI Y14.5M, 1982.
  2. CONTROLLING DIMENSION: INCH.
  3. DIMENSION L TO CENTER OF LEAD WHEN FORMED PARALLEL.
  4. DIMENSION B DOES NOT INCLUDE MOLD FLASH.

DIM	INCHES		MILLIMETERS	
	MIN	MAX	MIN	MAX
A	1.010	1.070	25.66	27.17
B	0.240	0.260	6.10	6.60
C	0.150	0.180	3.81	4.57
D	0.015	0.022	0.39	0.55
E	0.050 BSC		1.27 BSC	
F	0.050	0.070	1.27	1.77
G	0.100 BSC		2.54 BSC	
J	0.008	0.015	0.21	0.38
K	0.110	0.140	2.80	3.55
L	0.300 BSC		7.62 BSC	
M	0° - 15°		0° - 15°	
N	0.020	0.040	0.51	1.01

### 16.3 20-Pin Small Outline Integrated Circuit (Case 751D)

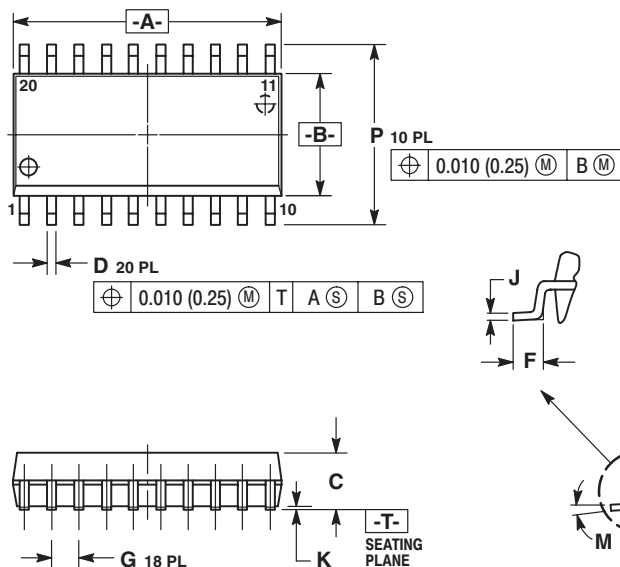

- NOTES:
1. DIMENSIONING AND TOLERANCING PER ANSI Y14.5M, 1982.
  2. CONTROLLING DIMENSION: MILLIMETER.
  3. DIMENSIONS A AND B DO NOT INCLUDE MOLD PROTRUSION.
  4. MAXIMUM MOLD PROTRUSION 0.150 (0.006) PER SIDE.
  5. DIMENSION D DOES NOT INCLUDE DAMBAR PROTRUSION. ALLOWABLE DAMBAR PROTRUSION SHALL BE 0.13 (0.005) TOTAL IN EXCESS OF D DIMENSION AT MAXIMUM MATERIAL CONDITION.

DIM	MILLIMETERS		INCHES	
	MIN	MAX	MIN	MAX
A	12.65	12.95	0.499	0.510
B	7.40	7.60	0.292	0.299
C	2.35	2.65	0.093	0.104
D	0.35	0.49	0.014	0.019
F	0.50	0.90	0.020	0.035
G	1.27 BSC		0.050 BSC	
J	0.25	0.32	0.010	0.012
K	0.10	0.25	0.004	0.009
M	0°	7°	0°	7°
P	10.05	10.55	0.395	0.415
R	0.25	0.75	0.010	0.029

### 16.4 28-Pin Plastic Dual In-Line Package (Case 710)

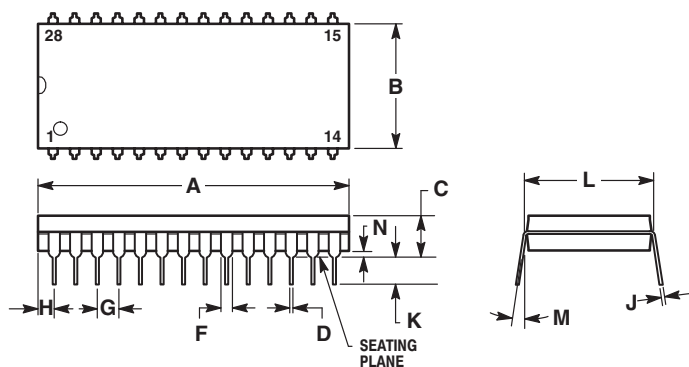

- NOTES:
1. POSITIONAL TOLERANCE OF LEADS (D), SHALL BE WITHIN 0.25mm (0.010) AT MAXIMUM MATERIAL CONDITION, IN RELATION TO SEATING PLANE AND EACH OTHER.
  2. DIMENSION L TO CENTER OF LEADS WHEN FORMED PARALLEL.
  3. DIMENSION B DOES NOT INCLUDE MOLD FLASH.

DIM	MILLIMETERS		INCHES	
	MIN	MAX	MIN	MAX
A	36.45	37.21	1.435	1.465
B	13.72	14.22	0.540	0.560
C	3.94	5.08	0.155	0.200
D	0.36	0.56	0.014	0.022
F	1.02	1.52	0.040	0.060
G	2.54 BSC		0.100 BSC	
H	1.65	2.16	0.065	0.085
J	0.20	0.38	0.008	0.015
K	2.92	3.43	0.115	0.135
L	15.24 BSC		0.600 BSC	
M	0°	15°	0°	15°
N	0.51	1.02	0.020	0.040

## 16.5 28-Pin Small Outline Integrated Circuit (Case 751F)

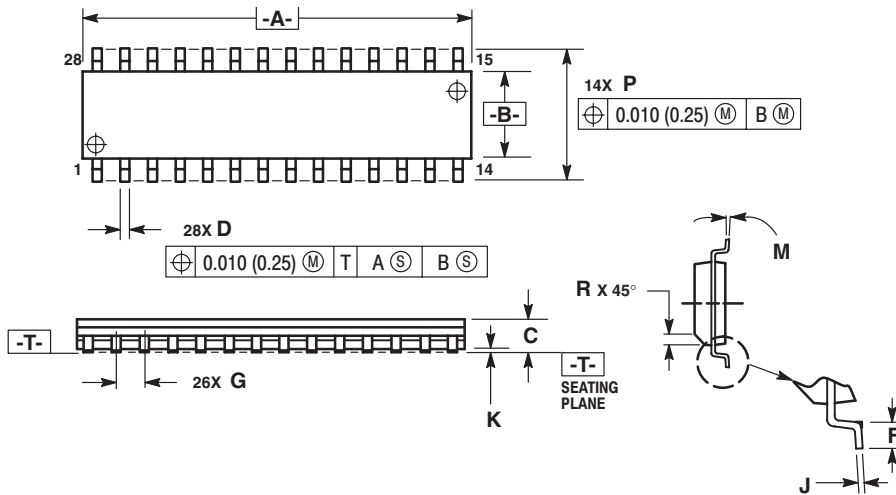
**NOTES:**

- DIMENSIONING AND TOLERANCING PER ANSI Y14.5M, 1982.
- CONTROLLING DIMENSION: MILLIMETER.
- DIMENSION A AND B DO NOT INCLUDE MOLD PROTRUSION.
- MAXIMUM MOLD PROTRUSION 0.15 (0.006) PER SIDE.
- DIMENSION D DOES NOT INCLUDE DAMBAR PROTRUSION. ALLOWABLE DAMBAR PROTRUSION SHALL BE 0.13 (0.005) TOTAL IN EXCESS OF D DIMENSION AT MAXIMUM MATERIAL CONDITION.

DIM	MILLIMETERS		INCHES	
	MIN	MAX	MIN	MAX
A	17.80	18.05	0.701	0.711
B	7.40	7.60	0.292	0.299
C	2.35	2.65	0.093	0.104
D	0.35	0.49	0.014	0.019
F	0.41	0.90	0.016	0.035
G	1.27 BSC		0.050 BSC	
J	0.23	0.32	0.009	0.013
K	0.13	0.29	0.005	0.011
M	0°	8°	0°	8°
P	10.05	10.55	0.395	0.415
R	0.25	0.75	0.010	0.029

## 16.6 20-Pin Windowed Ceramic Integrated Circuit (Case 732)

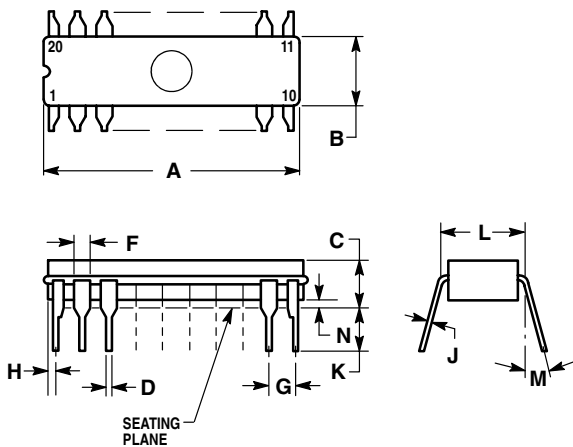
**NOTES:**

- LEADS WITHIN 0.010 DIAMETER, TRUE POSITION AT SEATING PLANE, AT MAXIMUM MATERIAL CONDITION.
- DIMENSION L TO CENTER OF LEADS WHEN FORMED PARALLEL.
- DIMENSIONS A AND B INCLUDE MENISCUS.

DIM	INCHES	
	MIN	MAX
A	0.940	0.990
B	0.260	0.295
C	0.150	0.200
D	0.015	0.022
F	0.055	0.065
G	0.100 BSC	
H	0.020	0.050
J	0.008	0.012
K	0.125	0.160
L	0.300 BSC	
M	0°	15°
N	0.010	0.040

## 16.7 28-Pin Windowed Ceramic Integrated Circuit (Case 733A)

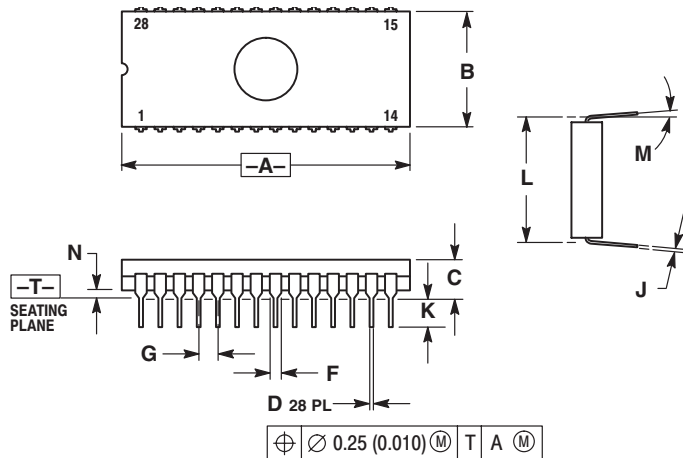

- NOTES:
1. DIMENSIONING AND TOLERANCING PER ANSI Y14.5M, 1982.
  2. CONTROLLING DIMENSION: INCH.
  3. DIMENSION A AND B INCLUDE MENISCUS.
  4. DIMENSION L TO CENTER OF LEADS WHEN FORMED PARALLEL.

DIM	INCHES		MILLIMETERS	
	MIN	MAX	MIN	MAX
A	1.435	1.490	36.45	37.84
B	0.500	0.605	12.70	15.36
C	0.160	0.240	4.06	6.09
D	0.015	0.022	0.38	0.55
F	0.050	0.065	1.27	1.65
G	0.100 BSC		2.54 BSC	
J	0.008	0.012	0.20	0.30
K	0.125	0.160	3.17	4.06
L	0.600 BSC		15.24 BSC	
M	0° 15°		0° 15°	
N	0.020	0.050	0.51	1.27

# Chapter 17

## Ordering Information

### 17.1 Introduction

This section contains instructions for ordering the various erasable programmable read-only memory (EPROM) versions of the MC68HC05JJ/JP Family of microcontrollers.

### 17.2 MC68HC705JJ7 Order Numbers

MC order numbers for the available 20-pin package types are shown here.

Package Type	EPO Oscillator Type <sup>(1)</sup>	LPO Frequency (kHz)	Operating Temperature Range	Order Number
Plastic DIP <sup>(2)</sup>	XTAL	100	-40 to 85°C	MC68HC705JJ7CP
SOIC <sup>(3)</sup>	XTAL	100	-40 to 85°C	MC68HC705JJ7CDW
CERDIP <sup>(4), (5)</sup>	XTAL	100	-40 to 85°C	MC68HC705JJ7S
Plastic DIP	RC	100	-40 to 85°C	MC68HRC705JJ7CP
SOIC	RC	100	-40 to 85°C	MC68HRC705JJ7CDW
CERDIP <sup>(5)</sup>	RC	100	-40 to 85°C	MC68HRC705JJ7S
Plastic DIP	XTAL	500	-40 to 85°C	MC68HC705SJ7CP
SOIC	XTAL	500	-40 to 85°C	MC68HC705SJ7CDW
CERDIP <sup>(5)</sup>	XTAL	500	-40 to 85°C	MC68HC705SJ7S

1. Crystal/ceramic resonator or RC oscillator
2. Plastic dual in-line package (P, case outline 738)
3. Small outline integrated circuit package (DW, case outline 751D)
4. Windowed ceramic dual in-line package (S, case outline 732)
5. CERDIP parts are only guaranteed at room temperature and are for evaluation purposes only.

## 17.3 MC68HC705JP7 Order Numbers

MC order numbers for the available 28-pin package types are shown here.

Package Type	EPO Oscillator Type <sup>(1)</sup>	LPO Frequency (kHz)	Operating Temperature Range	Order Number
Plastic DIP <sup>(2)</sup>	XTAL	100	-40 to 85°C	MC68HC705JP7CP
SOIC <sup>(3)</sup>	XTAL	100	-40 to 85°C	MC68HC705JP7CDW
CERDIP <sup>(4), (5)</sup>	XTAL	100	-40 to 85°C	MC68HC705JP7S
Plastic DIP	RC	100	-40 to 85°C	MC68HRC705JP7CP
SOIC	RC	100	-40 to 85°C	MC68HRC705JP7CDW
CERDIP <sup>(5)</sup>	RC	100	-40 to 85°C	MC68HRC705JP7S
Plastic DIP	XTAL	500	-40 to 85°C	MC68HC705SP7CP
SOIC	XTAL	500	-40 to 85°C	MC68HC705SP7CDW
CERDIP <sup>(5)</sup>	XTAL	500	-40 to 85°C	MC68HC705SP7S

1. Crystal/ceramic resonator or RC oscillator
2. Plastic dual in-line package (P, case outline 710)
3. Small outline integrated circuit package (DW, case outline 751F)
4. Windowed ceramic dual in-line package (S, case outline 733A)
5. CERDIP parts are only guaranteed at room temperature and are for evolution purposes only.



## **How to Reach Us:**

### **Home Page:**

[www.freescale.com](http://www.freescale.com)

### **E-mail:**

[support@freescale.com](mailto:support@freescale.com)

### **USA/Europe or Locations Not Listed:**

Freescale Semiconductor  
Technical Information Center, CH370  
1300 N. Alma School Road  
Chandler, Arizona 85224  
+1-800-521-6274 or +1-480-768-2130  
[support@freescale.com](mailto:support@freescale.com)

### **Europe, Middle East, and Africa:**

Freescale Halbleiter Deutschland GmbH  
Technical Information Center  
Schatzbogen 7  
81829 Muenchen, Germany  
+44 1296 380 456 (English)  
+46 8 52200080 (English)  
+49 89 92103 559 (German)  
+33 1 69 35 48 48 (French)  
[support@freescale.com](mailto:support@freescale.com)

### **Japan:**

Freescale Semiconductor Japan Ltd.  
Headquarters  
ARCO Tower 15F  
1-8-1, Shimo-Meguro, Meguro-ku,  
Tokyo 153-0064  
Japan  
0120 191014 or +81 3 5437 9125  
[support.japan@freescale.com](mailto:support.japan@freescale.com)

### **Asia/Pacific:**

Freescale Semiconductor Hong Kong Ltd.  
Technical Information Center  
2 Dai King Street  
Tai Po Industrial Estate  
Tai Po, N.T., Hong Kong  
+800 2666 8080  
[support.asia@freescale.com](mailto:support.asia@freescale.com)

### **For Literature Requests Only:**

Freescale Semiconductor Literature Distribution Center  
P.O. Box 5405  
Denver, Colorado 80217  
1-800-441-2447 or 303-675-2140  
Fax: 303-675-2150  
[LDCForFreescaleSemiconductor@hibbertgroup.com](mailto:LDCForFreescaleSemiconductor@hibbertgroup.com)

Information in this document is provided solely to enable system and software implementers to use Freescale Semiconductor products. There are no express or implied copyright licenses granted hereunder to design or fabricate any integrated circuits or integrated circuits based on the information in this document.

Freescale Semiconductor reserves the right to make changes without further notice to any products herein. Freescale Semiconductor makes no warranty, representation or guarantee regarding the suitability of its products for any particular purpose, nor does Freescale Semiconductor assume any liability arising out of the application or use of any product or circuit, and specifically disclaims any and all liability, including without limitation consequential or incidental damages. "Typical" parameters that may be provided in Freescale Semiconductor data sheets and/or specifications can and do vary in different applications and actual performance may vary over time. All operating parameters, including "Typicals", must be validated for each customer application by customer's technical experts. Freescale Semiconductor does not convey any license under its patent rights nor the rights of others. Freescale Semiconductor products are not designed, intended, or authorized for use as components in systems intended for surgical implant into the body, or other applications intended to support or sustain life, or for any other application in which the failure of the Freescale Semiconductor product could create a situation where personal injury or death may occur. Should Buyer purchase or use Freescale Semiconductor products for any such unintended or unauthorized application, Buyer shall indemnify and hold Freescale Semiconductor and its officers, employees, subsidiaries, affiliates, and distributors harmless against all claims, costs, damages, and expenses, and reasonable attorney fees arising out of, directly or indirectly, any claim of personal injury or death associated with such unintended or unauthorized use, even if such claim alleges that Freescale Semiconductor was negligent regarding the design or manufacture of the part.

Freescale™ and the Freescale logo are trademarks of Freescale Semiconductor, Inc. All other product or service names are the property of their respective owners.

© Freescale Semiconductor, Inc. 2005. All rights reserved.

## Looking for pricing, stock, or lifecycle information?

Click below to explore more details on WIN SOURCE:

⊖ [View MC68HC705JP7CDW on WIN SOURCE](#)

⊖ [NXP / Nexperia Information](#)

## Optimize Your Supply Chain with WIN SOURCE Solutions

- ✓ Global Sourcing Solution
- ✓ Obsolete Management
- ✓ Cost Control Management
- ✓ Shortage Management
- ✓ Alternative Solution
- ✓ Excess Inventory Management