



**THE DATASHEET OF
MC100EPT622FAG**



3.3 V LVTTTL/LVCMOS to LVPECL Translator

MC100EPT622

Description

The MC100EPT622 is a 10-Bit LVTTTL/LVCMOS to LVPECL translator. Because LVPECL (Positive ECL) levels are used only +3.3 V and ground are required. The device has an OR-ed enable input which can accept either LVPECL (ENPECL) or TTL/LVCMOS inputs (ENTTL). If the inputs are left open, they will default to the enable state. The device design has been optimized for low channel-to-channel skew.

Features

- 450 ps Typical Propagation Delay
- Maximum Frequency > 1.5 GHz Typical
- PECL Mode
- Operating Range: $V_{CC} = 3.0\text{ V}$ to 3.8 V with $V_{EE} = 0\text{ V}$
- PNP LVTTTL Inputs for Minimal Loading
- Q Output Will Default HIGH with Inputs Open
- The 100 Series Contains Temperature Compensation
- These Devices are Pb-Free, Halogen Free and are RoHS Compliant



ON Semiconductor®

www.onsemi.com

MARKING DIAGRAMS*

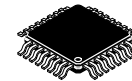

LQFP-32
FA SUFFIX
CASE 561AB

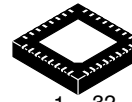
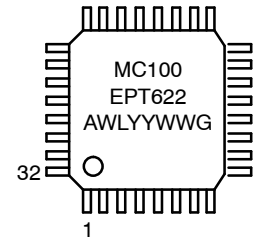

QFN32
MN SUFFIX
CASE 488AM

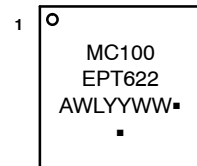

- A = Assembly Location
- WL = Wafer Lot
- YY = Year
- WW = Work Week
- G or ▪ = Pb-Free Package

(Note: Microdot may be in either location)

*For additional marking information, refer to Application Note [AND8002/D](#).

Table 1. TRUTH TABLE

ENPECL	ENTTL	D	Q
H	X	H	H
H	X	L	L
X	H	H	H
X	H	L	L
L	L	X	L

ORDERING INFORMATION

See detailed ordering and shipping information in the package dimensions section on page 6 of this data sheet.

MC100EPT622

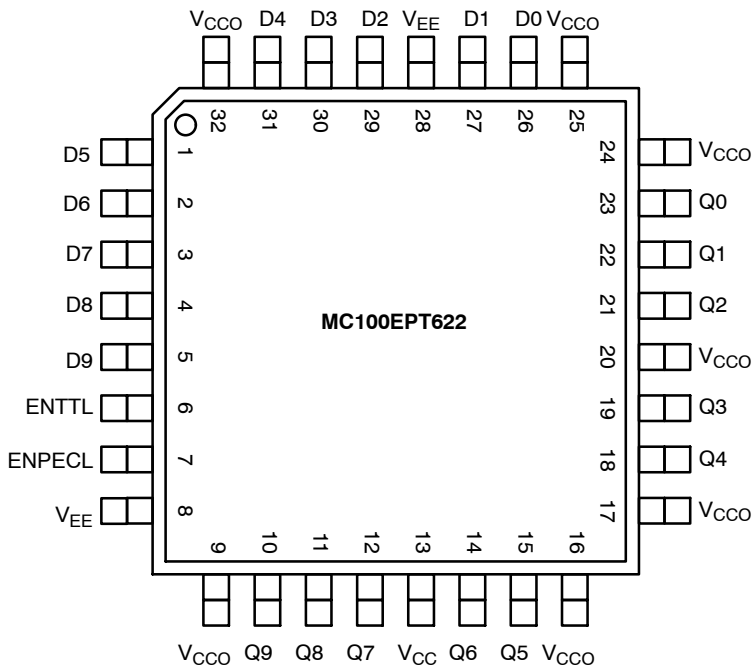

Warning: All V_{CC} , V_{CCO} , and V_{EE} pins must be externally connected to Power Supply to guarantee proper operation.

Figure 1. 32-Lead LQFP Pinout (Top View)

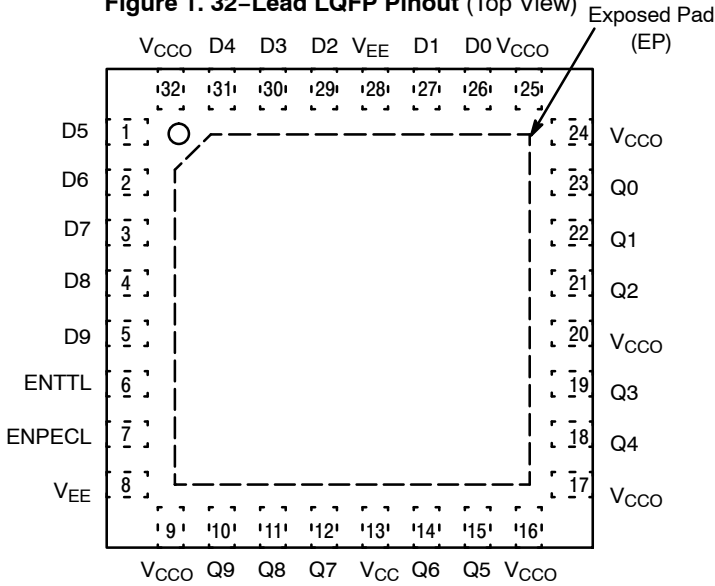

Figure 3. 32-Lead QFN Pinout (Top View)

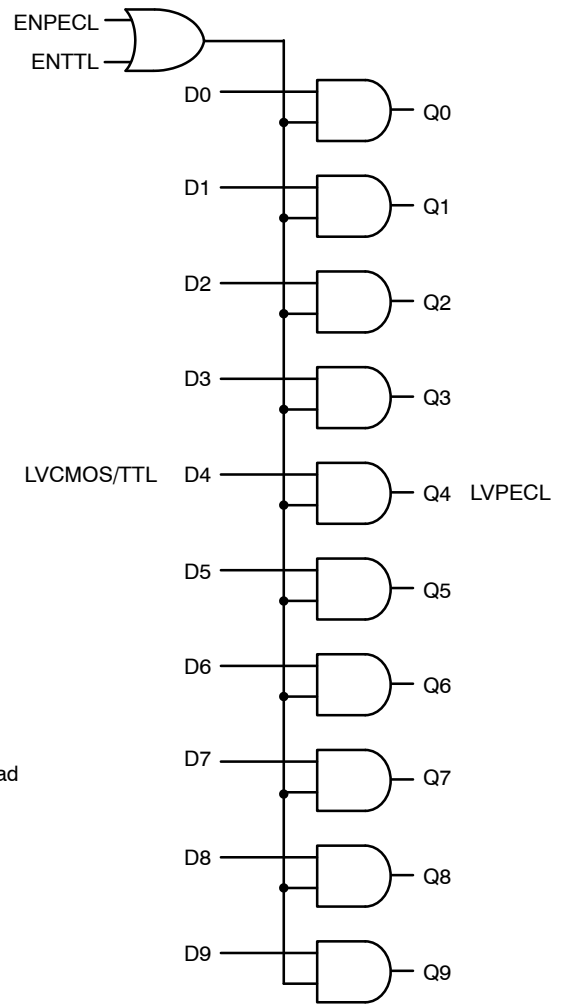

Figure 2. Logic Symbol

Table 1. PIN DESCRIPTION

Pin	Function
D0:9	Data Input (TTL)
Q0:9	Data Outputs (PECL)
ENTTL	Enable Control (TTL)
ENPECL	Enable Control (PECL)
V_{CC} , V_{CCO}	Positive Supply
V_{EE}	Ground
EP	The exposed pad (EP) on the QFN-32 package bottom is thermally connected to the die for improved heat transfer out of the package. The exposed pad must be attached to a heat-sinking conduit. The pad is electrically connected to V_{EE} .

MC100EPT622

Table 2. ATTRIBUTES

Characteristics	Value
Internal Input Pulldown Resistor	N/A
Internal Input Pullup Resistor	N/A
ESD Protection Human Body Model Machine Model Charged Device Model	> 2 kV > 150 V > 2 kV
Moisture Sensitivity, Indefinite Time Out of Drypack	Pb-Free Pkg
LQFP-32 QFN-32	Level 2 Level 1
Flammability Rating Oxygen Index: 28 to 34	UL 94 V-0 @ 0.125 in
Transistor Count	596 Devices
Meets or exceeds JEDEC Spec EIA/JESD78 IC Latchup Test	

Table 3. MAXIMUM RATINGS

Symbol	Parameter	Condition 1	Condition 2	Rating	Unit
V_{CC}	Power Supply	$V_{EE} = 0\text{ V}$		5	V
V_I	Input Voltage	$V_{EE} = 0\text{ V}$	$V_I \leq V_{CC}$	5 to 0	V
I_{out}	Output Current	Continuous Surge		50 100	mA mA
T_A	Operating Temperature Range			-40 to +85	°C
T_{stg}	Storage Temperature Range			-65 to +150	°C
θ_{JA}	Thermal Resistance (Junction-to-Ambient)	0 lfp 500 lfp	32 LQFP 32 LQFP	80 55	°C/W °C/W
θ_{JC}	Thermal Resistance (Junction-to-Case)	Standard Board	32 LQFP	12 to 17	°C/W
θ_{JA}	Thermal Resistance (Junction-to-Ambient)	0 lfp 500 lfp	QFN-32 QFN-32	31 27	°C/W °C/W
θ_{JC}	Thermal Resistance (Junction-to-Case)	2S2P	QFN-32	12	°C/W
T_{sol}	Wave Solder			265	°C

Stresses exceeding those listed in the Maximum Ratings table may damage the device. If any of these limits are exceeded, device functionality should not be assumed, damage may occur and reliability may be affected.

Table 4. TTL INPUT DC CHARACTERISTICS ($V_{CC} = 3.3\text{ V}$, $GND = 0.0\text{ V}$, $T_A = -40^\circ\text{C}$ to 85°C)

Symbol	Characteristic	Condition	Min	Typ	Max	Unit
I_{IH}	Input HIGH Current	$V_{IN} = 2.7\text{ V}$			25	μA
I_{IHH}	Input HIGH Current MAX	$V_{IN} = V_{CC}$			100	μA
I_{IL}	Input LOW Current	$V_{IN} = 0.5\text{ V}$			-0.6	mA
V_{IK}	Input Clamp Voltage	$I_{IN} = -18\text{ mA}$	-1.2	-0.9		V
V_{IH}	Input HIGH Voltage		2.0			V
V_{IL}	Input LOW Voltage				0.8	V

NOTE: Device will meet the specifications after thermal equilibrium has been established when mounted in a test socket or printed circuit board with maintained transverse airflow greater than 500 lfp.

MC100EPT622

Table 5. PECL INPUT DC CHARACTERISTICS $V_{CC} = 3.3\text{ V}$, $GND = 0.0\text{ V}$, $T_A = -40^\circ\text{C}$ to 85°C

Symbol	Characteristic	Condition	Min	Typ	Max	Unit
I_{IH}	Input HIGH Current	$V_{IN} = 2420\text{ mV}$			150	μA
I_{IL}	Input LOW Current	$V_{IN} = 1490\text{ mV}$			200	μA
V_{IH}	Input HIGH Voltage		2075		2420	mV
V_{IL}	Input LOW Voltage		1490		1675	mV

NOTE: Device will meet the specifications after thermal equilibrium has been established when mounted in a test socket or printed circuit board with maintained transverse airflow greater than 500 lpm.

Table 6. PECL OUTPUT DC CHARACTERISTICS $V_{CC} = 3.3\text{ V}$, $GND = 0.0\text{ V}$ (Note 1)

Symbol	Characteristic	-40°C			25°C			85°C			Unit
		Min	Typ	Max	Min	Typ	Max	Min	Typ	Max	
I_{EE}	Power Supply Current	85	115	145	90	120	155	95	130	155	mA
V_{OH}	Output High Voltage (Note 2)	2155	2280	2405	2155	2280	2405	2155	2280	2405	mV
V_{OL}	Output Low Voltage (Note 2)	1355	1520	1700	1355	1520	1700	1355	1520	1700	mV

NOTE: Device will meet the specifications after thermal equilibrium has been established when mounted in a test socket or printed circuit board with maintained transverse airflow greater than 500 lpm.

1. Input and output parameters vary 1:1 with V_{CC} .
2. All loading with $50\ \Omega$ to $V_{CC}-2.0\text{ V}$.

Table 7. AC CHARACTERISTICS $V_{CC} = 3.0\text{ V}$ to 3.8 V (Note 3)

Symbol	Characteristic	-40°C			25°C			85°C			Unit
		Min	Typ	Max	Min	Typ	Max	Min	Typ	Max	
f_{max}	Maximum Frequency (See Figure 4)	1.0	1.5		1.0	1.5		1.0	1.5		GHz
t_{PLH} , t_{PHL}	Propagation Delay to Output (Figure 5, Note 4) D to Q ENPECL to Q ENTTL to Q	100 150 300	450 500 450	800 875 800	100 150 300	500 500 500	875 875 800	100 200 300	500 550 500	800 925 800	ps
t_{JITTER}	Random Clock Jitter (RMS) (See Figure 4)		0.7	3.0		0.7	3.0		0.7	3.0	ps
t_r / t_f	Output Rise/Fall Times (20% – 80%)	100	200	450	100	200	250	100	200	300	ps
T_{SKEW}	Duty Cycle Skew (Note 5) D to Q Channel 0–7 Channel 8–9 ENPECL to Q ENTTL to Q		120 200 120 100	375 775 400 275		120 200 120 100	375 775 400 275		120 200 120 100	375 775 400 275	ps

NOTE: Device will meet the specifications after thermal equilibrium has been established when mounted in a test socket or printed circuit board with maintained transverse airflow greater than 500 lpm.

3. Measured using a 2.4 V source, 50% duty cycle clock source. All loading with $50\ \Omega$ to $V_{CC}-2.0\text{ V}$.
4. 1.5 V to 50% point of the output.
5. Duty cycle skew $|t_{PLH} - t_{PHL}|$ on the specific path.

MC100EPT622

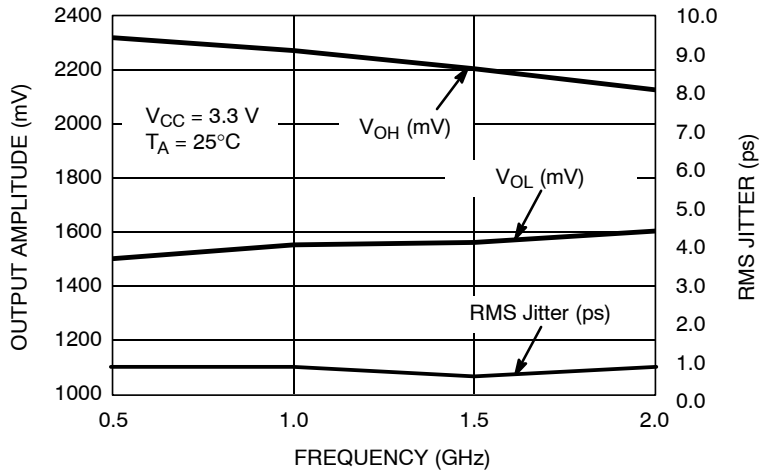

Figure 4. Average Output Amplitude/Jitter (3.3 V, 25°C)

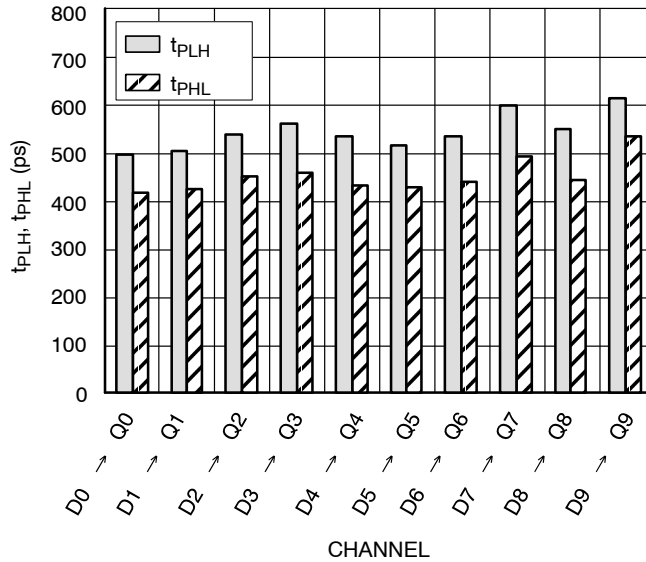

Figure 5. Average Propagation Delay (3.3 V, 25°C)

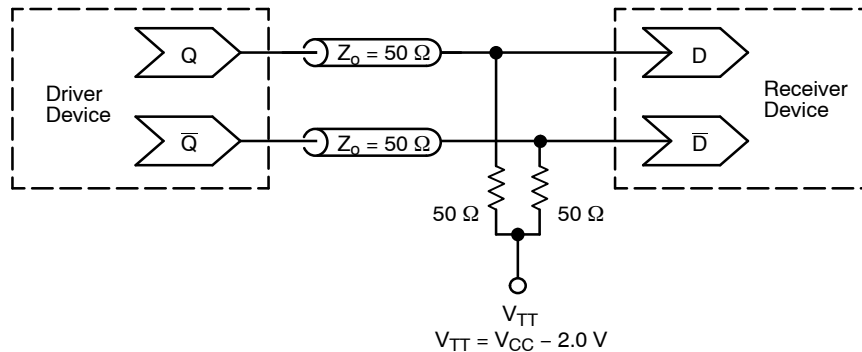

Figure 6. Typical Termination for Output Driver and Device Evaluation (See Application Note [AND8020/D](#) – Termination of ECL Logic Devices.)

MC100EPT622

ORDERING INFORMATION

Device	Package	Shipping
MC100EPT622FAG	LQFP-32 (Pb-Free)	250 Units / Tray
MC100EPT622MNG	QFN32 (Pb-Free)	74 Units / Rail

Resource Reference of Application Notes

- AN1405/D** – ECL Clock Distribution Techniques
- AN1406/D** – Designing with PECL (ECL at +5.0 V)
- AN1503/D** – ECLinPS™ I/O SPiCE Modeling Kit
- AN1504/D** – Metastability and the ECLinPS Family
- AN1568/D** – Interfacing Between LVDS and ECL
- AN1672/D** – The ECL Translator Guide
- AND8001/D** – Odd Number Counters Design
- AND8002/D** – Marking and Date Codes
- AND8020/D** – Termination of ECL Logic Devices
- AND8066/D** – Interfacing with ECLinPS
- AND8090/D** – AC Characteristics of ECL Devices

ECLinPS is a trademark of Semiconductor Components Industries, LLC (SCILLC) or its subsidiaries in the United States and/or other countries.

MECHANICAL CASE OUTLINE

PACKAGE DIMENSIONS

ON Semiconductor®

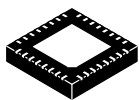

1 32

SCALE 2:1

QFN32 5x5, 0.5P
CASE 488AM
ISSUE A

DATE 23 OCT 2013

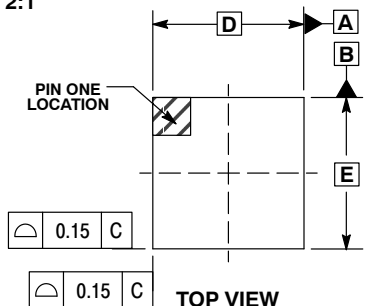

TOP VIEW

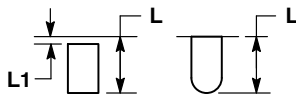

DETAIL A
ALTERNATE TERMINAL
CONSTRUCTIONS

NOTES:

1. DIMENSIONS AND TOLERANCING PER ASME Y14.5M, 1994.
2. CONTROLLING DIMENSION: MILLIMETERS.
3. DIMENSION b APPLIES TO PLATED TERMINAL AND IS MEASURED BETWEEN 0.15 AND 0.30MM FROM THE TERMINAL TIP. COPLANARITY APPLIES TO THE EXPOSED PAD AS WELL AS THE TERMINALS.
4. COPLANARITY APPLIES TO THE EXPOSED PAD AS WELL AS THE TERMINALS.

MILLIMETERS		
DIM	MIN	MAX
A	0.80	1.00
A1	---	0.05
A3	0.20	REF
b	0.18	0.30
D	5.00	BSC
D2	2.95	3.25
E	5.00	BSC
E2	2.95	3.25
e	0.50	BSC
K	0.20	---
L	0.30	0.50
L1	---	0.15

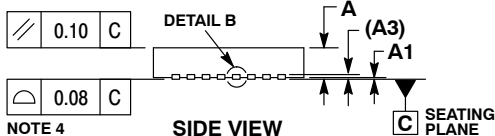

SIDE VIEW

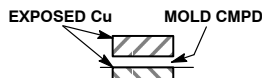

DETAIL B
ALTERNATE
CONSTRUCTION

GENERIC MARKING DIAGRAM*

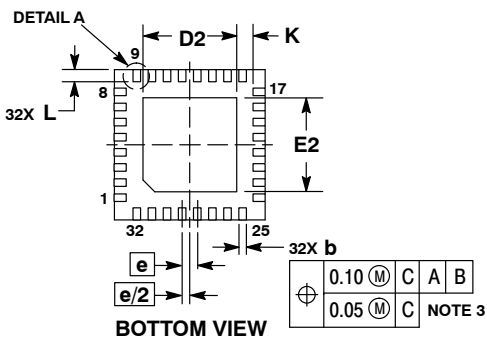

BOTTOM VIEW

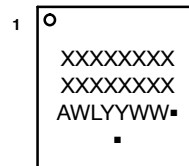

- XXXXXX = Specific Device Code
- A = Assembly Location
- WL = Wafer Lot
- YY = Year
- WW = Work Week
- = Pb-Free Package

(Note: Microdot may be in either location)
*This information is generic. Please refer to device data sheet for actual part marking.
Pb-Free indicator, "G" or microdot "▪", may or may not be present.

RECOMMENDED SOLDERING FOOTPRINT*

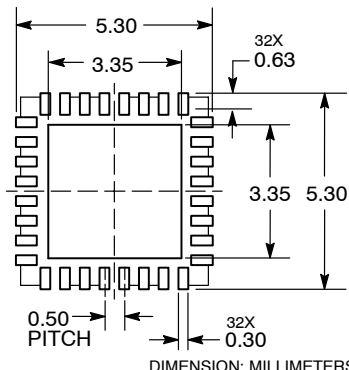

*For additional information on our Pb-Free strategy and soldering details, please download the ON Semiconductor Soldering and Mounting Techniques Reference Manual, SOLDERRM/D.

DOCUMENT NUMBER:	98AON20032D	Electronic versions are uncontrolled except when accessed directly from the Document Repository. Printed versions are uncontrolled except when stamped "CONTROLLED COPY" in red.
DESCRIPTION:	QFN32 5x5 0.5P	PAGE 1 OF 1

ON Semiconductor and ON are trademarks of Semiconductor Components Industries, LLC dba ON Semiconductor or its subsidiaries in the United States and/or other countries. ON Semiconductor reserves the right to make changes without further notice to any products herein. ON Semiconductor makes no warranty, representation or guarantee regarding the suitability of its products for any particular purpose, nor does ON Semiconductor assume any liability arising out of the application or use of any product or circuit, and specifically disclaims any and all liability, including without limitation special, consequential or incidental damages. ON Semiconductor does not convey any license under its patent rights nor the rights of others.

MECHANICAL CASE OUTLINE
PACKAGE DIMENSIONS

ON Semiconductor®



LQFP-32, 7x7
CASE 561AB-01
ISSUE O

DATE 19 JUN 2008

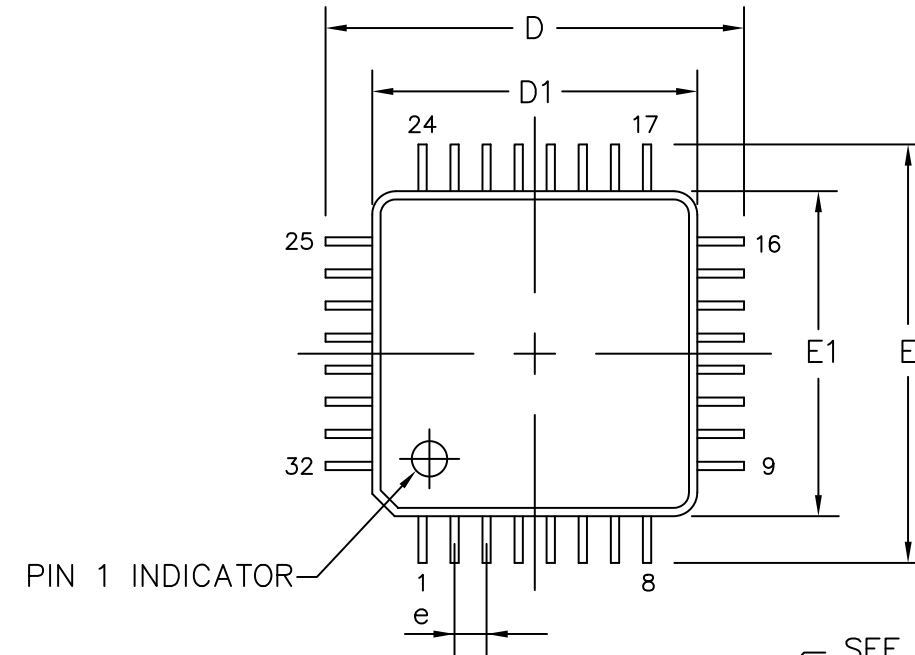

SYMBOL	MIN	NOM	MAX
A	—	—	1.60
A1	0.05	—	0.15
A2	1.35	1.40	1.45
B	0.30	0.37	0.45
B1	0.30	0.35	0.40
C	0.09	—	0.20
C1	0.09	—	0.16
D	9.00 BSC		
D1	7.00 BSC		
E	9.00 BSC		
E1	7.00 BSC		
e	0.80 BSC		
L	0.45	0.60	0.75
L1	1.00		
R1	0.08	—	0.20
α°	11	—	13
β°	0	—	7
γ°	0	—	—

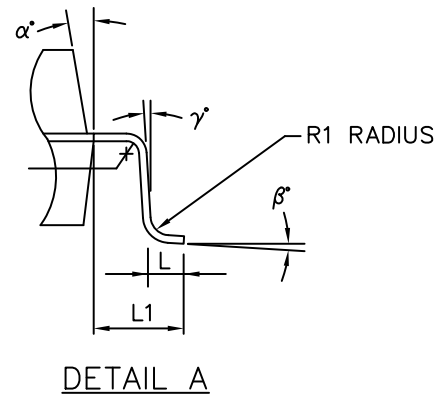
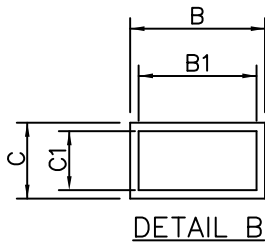
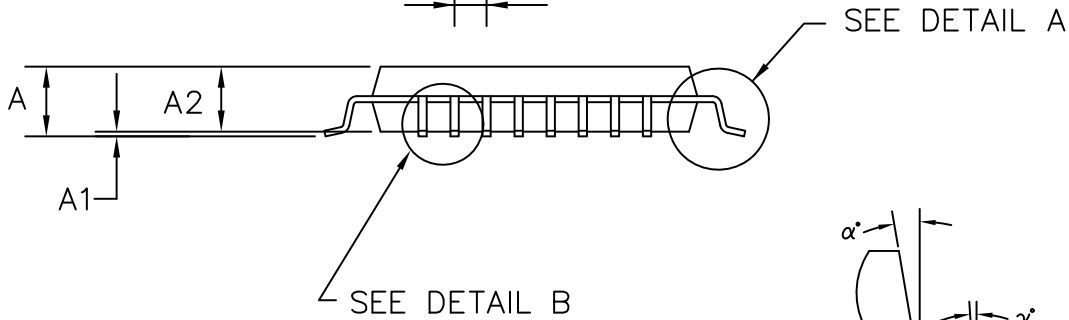

ALL DIMENSIONS IN MM

DOCUMENT NUMBER:	98AON30893E	Electronic versions are uncontrolled except when accessed directly from the Document Repository. Printed versions are uncontrolled except when stamped "CONTROLLED COPY" in red.
DESCRIPTION:	32 LEAD LQFP, 7X7	PAGE 1 OF 1

ON Semiconductor and are trademarks of Semiconductor Components Industries, LLC dba ON Semiconductor or its subsidiaries in the United States and/or other countries. ON Semiconductor reserves the right to make changes without further notice to any products herein. ON Semiconductor makes no warranty, representation or guarantee regarding the suitability of its products for any particular purpose, nor does ON Semiconductor assume any liability arising out of the application or use of any product or circuit, and specifically disclaims any and all liability, including without limitation special, consequential or incidental damages. ON Semiconductor does not convey any license under its patent rights nor the rights of others.

onsemi, **Onsemi**, and other names, marks, and brands are registered and/or common law trademarks of Semiconductor Components Industries, LLC dba "**onsemi**" or its affiliates and/or subsidiaries in the United States and/or other countries. **onsemi** owns the rights to a number of patents, trademarks, copyrights, trade secrets, and other intellectual property. A listing of **onsemi**'s product/patent coverage may be accessed at www.onsemi.com/site/pdf/Patent-Marking.pdf. **onsemi** reserves the right to make changes at any time to any products or information herein, without notice. The information herein is provided "as-is" and **onsemi** makes no warranty, representation or guarantee regarding the accuracy of the information, product features, availability, functionality, or suitability of its products for any particular purpose, nor does **onsemi** assume any liability arising out of the application or use of any product or circuit, and specifically disclaims any and all liability, including without limitation special, consequential or incidental damages. Buyer is responsible for its products and applications using **onsemi** products, including compliance with all laws, regulations and safety requirements or standards, regardless of any support or applications information provided by **onsemi**. "Typical" parameters which may be provided in **onsemi** data sheets and/or specifications can and do vary in different applications and actual performance may vary over time. All operating parameters, including "Typicals" must be validated for each customer application by customer's technical experts. **onsemi** does not convey any license under any of its intellectual property rights nor the rights of others. **onsemi** products are not designed, intended, or authorized for use as a critical component in life support systems or any FDA Class 3 medical devices or medical devices with a same or similar classification in a foreign jurisdiction or any devices intended for implantation in the human body. Should Buyer purchase or use **onsemi** products for any such unintended or unauthorized application, Buyer shall indemnify and hold **onsemi** and its officers, employees, subsidiaries, affiliates, and distributors harmless against all claims, costs, damages, and expenses, and reasonable attorney fees arising out of, directly or indirectly, any claim of personal injury or death associated with such unintended or unauthorized use, even if such claim alleges that **onsemi** was negligent regarding the design or manufacture of the part. **onsemi** is an Equal Opportunity/Affirmative Action Employer. This literature is subject to all applicable copyright laws and is not for resale in any manner.

ADDITIONAL INFORMATION

TECHNICAL PUBLICATIONS:

Technical Library: www.onsemi.com/design/resources/technical-documentation
onsemi Website: www.onsemi.com

ONLINE SUPPORT: www.onsemi.com/support

For additional information, please contact your local Sales Representative at www.onsemi.com/support/sales

Looking for pricing, stock, or lifecycle information?

Click below to explore more details on WIN SOURCE:

 [View MC100EPT622FAG](#) on WIN SOURCE

 [ON Semiconductor](#) Information

Optimize Your Supply Chain with WIN SOURCE Solutions

-  Global Sourcing Solution
-  Obsolete Management
-  Cost Control Management
-  Shortage Management
-  Alternative Solution
-  Excess Inventory Management