



## 16-Bit Microcontroller with Infrared Module

### General Description

The MAXQ613 is a low-power, 16-bit MAXQ® microcontroller designed for low-power applications including universal remote controls, consumer electronics, and white goods. The device combines a powerful 16-bit RISC microcontroller and integrated peripherals including a universal synchronous/asynchronous receiver-transmitter (USART) and an SPI master/slave communications port, along with an IR module with carrier frequency generation and flexible port I/O capable of multiplexed keypad control.

The device includes 48KB of flash program memory and 1.5KB of data SRAM. Intellectual property (IP) protection is provided by a secure MMU that supports multiple application privilege levels and protects code against copying and reverse engineering. Privilege levels enable vendors to provide libraries and applications to execute on the device, while limiting access to only data and code allowed by their privilege level.

For the ultimate in low-power battery-operated performance, the device includes an ultra-low-power stop mode (0.2µA typ). In this mode, the minimum amount of circuitry is powered. Wake-up sources include external interrupts, the power-fail interrupt, and a timer interrupt. The microcontroller runs from a wide 1.70V to 3.6V operating voltage.

### Applications

Remote Controls	Consumer Electronics
Battery-Powered	Home Appliances
Portable Equipment	White Goods

### Features

- ◆ High-Performance, Low-Power, 16-Bit RISC Core
- ◆ DC to 12MHz Operation Across Entire Operating Range
- ◆ 1.70V to 3.6V Operating Voltage
- ◆ 33 Total Instructions for Simplified Programming
- ◆ Three Independent Data Pointers Accelerate Data Movement with Automatic Increment/Decrement
- ◆ Dedicated Pointer for Direct Read from Code Space
- ◆ 16-Bit Instruction Word, 16-Bit Data Bus
- ◆ 16 x 16-Bit General-Purpose Working Registers
- ◆ Secure MMU for Application Partitioning and IP Protection
- ◆ Memory Features
  - 48KB Program Flash Memory
  - 512-Byte Sectors
  - 20,000 Erase/Write Cycles per Sector
  - Masked ROM Available
  - 1.5KB Data SRAM
- ◆ Additional Peripherals
  - Power-Fail Warning
  - Power-On Reset (POR)/Brownout Reset
  - Automatic IR Carrier Frequency Generation and Modulation
  - Two 16-Bit Programmable Timers/Counters with Prescaler and Capture/Compare
  - One SPI and One USART Port
  - Programmable Watchdog Timer
  - 8kHz Nanopower Ring Oscillator Wake-Up Timer
  - Up to 24 General-Purpose I/Os
- ◆ Low Power Consumption
  - 0.2µA (typ), 2.0µA (max) in Stop Mode, TA = +25°C, Power-Fail Monitor Disabled
  - 3.25mA (typ) at 12MHz in Active Mode

### Ordering Information/Selector Guide

PART	TEMP RANGE	OPERATING VOLTAGE (V)	PROGRAM MEMORY (KB)	DATA MEMORY (KB)	GPIO	PIN-PACKAGE
MAXQ613A-0000+	0°C to +70°C	1.7 to 3.6	48 Flash	1.5	20	32 TQFN-EP*
MAXQ613J-0000+	0°C to +70°C	1.7 to 3.6	48 Flash	1.5	24	44 TQFN-EP*
MAXQ613X-0000+	0°C to +70°C	1.7 to 3.6	48 Flash	1.5	24	Bare die

+Denotes a lead(Pb)-free/RoHS-compliant package.

\*EP = Exposed pad.

MAXQ is a registered trademark of Maxim Integrated Products, Inc.

**Note:** Some revisions of this device may incorporate deviations from published specifications known as errata. Multiple revisions of any device may be simultaneously available through various sales channels. For information about device errata, go to: [www.maximintegrated.com/errata](http://www.maximintegrated.com/errata).

**For pricing, delivery, and ordering information, please contact Maxim Direct at 1-888-629-4642, or visit Maxim Integrated's website at [www.maximintegrated.com](http://www.maximintegrated.com).**

# MAXQ613

## 16-Bit Microcontroller with Infrared Module

---

### TABLE OF CONTENTS

---

Absolute Maximum Ratings . . . . .	4
Recommended Operating Conditions . . . . .	4
SPI Electrical Characteristics . . . . .	6
Pin Configurations . . . . .	8
Pin Description . . . . .	8
Block Diagram . . . . .	11
Detailed Description . . . . .	11
Microprocessor . . . . .	11
Memory . . . . .	12
Memory Protection . . . . .	12
Stack Memory . . . . .	12
Utility ROM . . . . .	12
Watchdog Timer . . . . .	13
IR Carrier Generation and Modulation Timer . . . . .	13
Carrier Generation Module . . . . .	14
IR Transmission . . . . .	14
IR Transmit—Independent External Carrier and Modulator Outputs . . . . .	16
IR Receive . . . . .	16
Carrier Burst-Count Mode . . . . .	17
16-Bit Timers/Counters . . . . .	17
USART . . . . .	17
Serial Peripheral Interface (SPI) . . . . .	18
General-Purpose I/O . . . . .	20
On-Chip Oscillator . . . . .	20
ROM Loader . . . . .	20
Loading Flash Memory . . . . .	20
In-Application Flash Programming . . . . .	20
In-Circuit Debug and JTAG Interface . . . . .	21
Operating Modes . . . . .	21
Power-Fail Detection . . . . .	22
Applications Information . . . . .	26
Grounds and Bypassing . . . . .	26
Additional Documentation . . . . .	26
Deviations from the MAXQ610 User's Guide for the MAXQ613 . . . . .	27
Development and Technical Support . . . . .	27
Package Information . . . . .	27
Revision History . . . . .	28

## 16-Bit Microcontroller with Infrared Module

---

### LIST OF FIGURES

---

Figure 1. IR Transmit Frequency Shifting Example (IRCFME = 0) . . . . .	14
Figure 2. IR Transmit Carrier Generation and Carrier Modulator Control . . . . .	15
Figure 3. IR Transmission Waveform (IRCFME = 0) . . . . .	15
Figure 4. External IRTXM (Modulator) Output . . . . .	16
Figure 5. IR Capture . . . . .	17
Figure 6. Receive Burst-Count Example . . . . .	18
Figure 7. SPI Master Communication Timing . . . . .	19
Figure 8. SPI Slave Communication Timing . . . . .	19
Figure 9. On-Chip Oscillator . . . . .	20
Figure 10. In-Circuit Debugger . . . . .	21
Figure 11. Power-Fail Detection During Normal Operation . . . . .	22
Figure 12. Stop Mode Power-Fail Detection States with Power-Fail Monitor Enabled . . . . .	24
Figure 13. Stop Mode Power-Fail Detection with Power-Fail Monitor Disabled . . . . .	25

---

### LIST OF TABLES

---

Table 1. Memory Areas and Associated Maximum Privilege Levels . . . . .	12
Table 2. Watchdog Interrupt Timeout (Sysclk = 12MHz, CD[1:0] = 00) . . . . .	13
Table 3. USART Mode Details . . . . .	18
Table 4. Power-Fail Detection States During Normal Operation . . . . .	23
Table 5. Stop Mode Power-Fail Detection States with Power-Fail Monitor Enabled . . . . .	24
Table 6. Stop Mode Power-Fail Detection States with Power-Fail Monitor Disabled . . . . .	25

# MAXQ613

## 16-Bit Microcontroller with Infrared Module

### ABSOLUTE MAXIMUM RATINGS

Voltage Range on VDD with Respect to GND .....	-0.3V to +3.6V	44 TQFN (single-layer board)
Voltage Range on Any Lead with Respect to GND Except VDD .....	-0.3V to (VDD + 0.5V)	(derate 27mW/°C above +70°C).....2162.2mW
Continuous Power Dissipation (TA = +70°C)		44 TQFN (multilayer board)
32 TQFN (single-layer board)		(derate 37mW/°C above +70°C).....2963mW
(derate 21.3mW/°C above +70°C).....	1702.1mW	Operating Temperature Range.....
32 TQFN (multilayer board)		0°C to +70°C
(derate 34.5mW/°C above +70°C).....	2758.6mW	Storage Temperature Range.....
		-65°C to +150°C
		Lead Temperature (excluding dice; soldering, 10s) .....
		+300°C
		Soldering Temperature (reflow) .....
		+260°C

Stresses beyond those listed under "Absolute Maximum Ratings" may cause permanent damage to the device. These are stress ratings only, and functional operation of the device at these or any other conditions beyond those indicated in the operational sections of the specifications is not implied. Exposure to absolute maximum rating conditions for extended periods may affect device reliability.

### RECOMMENDED OPERATING CONDITIONS

(VDD = VRST to 3.6V, TA = 0°C to +70°C, unless otherwise noted.) (Note 1)

PARAMETER	SYMBOL	CONDITIONS	MIN	TYP	MAX	UNITS
Supply Voltage	VDD		VRST		3.6	V
1.8V Internal Regulator	VREG18		1.62	1.8	1.98	V
Power-Fail Warning Voltage for Supply	VPFW	Monitors VDD (Note 2)	1.75	1.8	1.85	V
Power-Fail Reset Voltage	VRST	Monitors VDD (Note 3)	1.64	1.67	1.70	V
POR Voltage	VPOR	Monitors VDD	1		1.42	V
RAM Data-Retention Voltage	VDRV	(Note 4)	1.0			V
Active Current	IDD_1	Sysclk = 12MHz (Note 5)		3.25	4	mA
Stop-Mode Current	IS1	Power-Fail Off	TA = +25°C	0.2	2.0	µA
			TA = 0°C to +70°C	0.2	8	
	IS2	Power-Fail On	TA = +25°C	22	29.5	
			TA = 0°C to +70°C	27.6	42	
Current Consumption During Power-Fail	IPFR	(Note 6)	$\frac{[(3 \times IS2) + ((PCI - 3) \times (IS1 + INANO))]}{PCI}$			µA
Power Consumption During POR	IPOR	(Note 7)	100			nA
Stop-Mode Resume Time	tON		$375 + (8192 \times t_{HFXIN})$			µs
Power-Fail Monitor Startup Time	tPFM_ON	(Note 4)	150			µs
Power-Fail Warning Detection Time	tPFW	(Note 8)	10			µs
Input Low Voltage for IRTX, IRRX, RESET, and All Port Pins	VIL		VGND		0.3 x VDD	V
Input High Voltage for IRTX, IRRX, RESET, and All Port Pins	VIH		0.7 x VDD		VDD	V

# MAXQ613

## 16-Bit Microcontroller with Infrared Module

### RECOMMENDED OPERATING CONDITIONS (continued)

(V<sub>DD</sub> = V<sub>RST</sub> to 3.6V, T<sub>A</sub> = 0°C to +70°C, unless otherwise noted.) (Note 1)

PARAMETER	SYMBOL	CONDITIONS	MIN	TYP	MAX	UNITS
Input Hysteresis (Schmitt)	V <sub>IHYS</sub>	V <sub>DD</sub> = 3.3V, T <sub>A</sub> = +25°C		300		mV
Input Low Voltage for HFXIN	V <sub>IL_HFXIN</sub>		V <sub>GND</sub>		0.3 x V <sub>DD</sub>	V
Input High Voltage for HFXIN	V <sub>IH_HFXIN</sub>		0.7 x V <sub>DD</sub>		V <sub>DD</sub>	V
IRRX Input Filter Pulse-Width Reject	t <sub>IRRX_R</sub>				50	ns
IRRX Input Filter Pulse-Width Accept	t <sub>IRRX_A</sub>		300			ns
Output Low Voltage for IRTX	V <sub>OL_IRTX</sub>	V <sub>DD</sub> = 3.6V, I <sub>OL</sub> = 25mA (Note 3)			1.0	V
		V <sub>DD</sub> = 2.35V, I <sub>OL</sub> = 10mA (Note 3)			1.0	
		V <sub>DD</sub> = 1.85V, I <sub>OL</sub> = 4.5mA			1.0	
Output Low Voltage for $\overline{\text{RESET}}$ and All Port Pins (Note 9)	V <sub>OL</sub>	V <sub>DD</sub> = 3.6V, I <sub>OL</sub> = 11mA (Note 3)		0.4	0.5	V
		V <sub>DD</sub> = 2.35V, I <sub>OL</sub> = 8mA (Note 3)		0.4	0.5	
		V <sub>DD</sub> = 1.85V, I <sub>OL</sub> = 4.5mA		0.4	0.5	
Output High Voltage for IRTX and All Port Pins	V <sub>OH</sub>	I <sub>OH</sub> = -2mA	V <sub>DD</sub> - 0.5		V <sub>DD</sub>	V
Input/Output Pin Capacitance for All Port Pins	C <sub>IO</sub>	(Note 4)			15	pF
Input Leakage Current	I <sub>L</sub>	Internal pullup disabled	-100		+100	nA
Input Pullup Resistor for $\overline{\text{RESET}}$ , IRTX, IRRX, P0, P1, P2	R <sub>PU</sub>	V <sub>DD</sub> = 3.0V, V <sub>OL</sub> = 0.4V (Note 4)	16	28	39	k $\Omega$
		V <sub>DD</sub> = 2.0V, V <sub>OL</sub> = 0.4V	17	30	41	
<b>EXTERNAL CRYSTAL/RESONATOR</b>						
Crystal/Resonator	f <sub>HFXIN</sub>		1		12	MHz
Crystal/Resonator Period	t <sub>HFXIN</sub>			1/f <sub>HFXIN</sub>		ns
Crystal/Resonator Warmup Time	t <sub>XTAL_RDY</sub>	From initial oscillation		8192 x t <sub>HFXIN</sub>		ms
Oscillator Feedback Resistor	R <sub>OSCF</sub>	(Note 4)	0.5	1.0	1.5	M $\Omega$
<b>EXTERNAL CLOCK INPUT</b>						
External Clock Frequency	f <sub>XCLK</sub>		DC		12	MHz
External Clock Period	t <sub>XCLK</sub>			1/f <sub>XCLK</sub>		ns
External Clock Duty Cycle	t <sub>XCLK_DUTY</sub>	(Note 4)	45		55	%
System Clock Frequency	f <sub>CK</sub>			f <sub>HFXIN</sub>		MHz
		HFXOUT = GND		f <sub>XCLK</sub>		
System Clock Period	t <sub>CK</sub>			1/f <sub>CK</sub>		ns
<b>NANOPOWER RING</b>						
Nanopower Ring Frequency	f <sub>NANO</sub>	T <sub>A</sub> = +25°C	3.0	8.0	20.0	kHz
		T <sub>A</sub> = +25°C, V <sub>DD</sub> = POR voltage (Note 4)	1.7	2.4		
Nanopower Ring Duty Cycle	t <sub>NANO</sub>	(Note 4)	40		60	%
Nanopower Ring Current	I <sub>NANO</sub>	Typical at V <sub>DD</sub> = 1.64V, T <sub>A</sub> = +25°C (Note 4)		40	400	nA

# MAXQ613

## 16-Bit Microcontroller with Infrared Module

### RECOMMENDED OPERATING CONDITIONS (continued)

(V<sub>DD</sub> = V<sub>RST</sub> to 3.6V, T<sub>A</sub> = 0°C to +70°C, unless otherwise noted.) (Note 1)

PARAMETER	SYMBOL	CONDITIONS	MIN	TYP	MAX	UNITS
<b>WAKE-UP TIMER</b>						
Wake-Up Timer Interval	t <sub>WAKEUP</sub>		1/f <sub>NANO</sub>		65,535/ f <sub>NANO</sub>	s
<b>FLASH MEMORY</b>						
System Clock During Flash Programming/Erase	f <sub>FPSYSCLK</sub>		6			MHz
Flash Erase Time	t <sub>ME</sub>	Mass erase	20		40	ms
	t <sub>ERASE</sub>	Page erase	20		40	
Flash Programming Time per Word	t <sub>PROG</sub>	(Note 10)	20		100	μs
Write/Erase Cycles			20,000			Cycles
Data Retention		T <sub>A</sub> = +25°C	100			Years
<b>IR</b>						
Carrier Frequency	f <sub>IR</sub>	(Note 4)			f <sub>CK</sub> /2	Hz

### SPI ELECTRICAL CHARACTERISTICS

(V<sub>DD</sub> = V<sub>RST</sub> to 3.6V, T<sub>A</sub> = 0°C to +70°C, unless otherwise noted.) (Note 11)

PARAMETER	SYMBOL	CONDITIONS	MIN	TYP	MAX	UNITS
SPI Master Operating Frequency	1/t <sub>MCK</sub>				f <sub>CK</sub> /2	MHz
SPI Slave Operating Frequency	1/t <sub>SCK</sub>				f <sub>CK</sub> /4	MHz
SPI I/O Rise/Fall Time	t <sub>SPI_RF</sub>	C <sub>L</sub> = 15pF, pullup = 560Ω	8.3		23.6	ns
SCLK Output Pulse-Width High/Low	t <sub>MCH</sub> , t <sub>MCL</sub>		t <sub>MCK</sub> /2 - t <sub>SPI_RF</sub>			ns
MOSI Output Hold Time After SCLK Sample Edge	t <sub>MOH</sub>		t <sub>MCK</sub> /2 - t <sub>SPI_RF</sub>			ns
MOSI Output Valid to Sample Edge	t <sub>MOV</sub>		t <sub>MCK</sub> /2 - t <sub>SPI_RF</sub>			ns
MISO Input Valid to SCLK Sample Edge Rise/Fall Setup	t <sub>MIS</sub>		25			ns
MISO Input to SCLK Sample Edge Rise/Fall Hold	t <sub>MIH</sub>		0			ns
SCLK Inactive to MOSI Inactive	t <sub>MLH</sub>		t <sub>MCK</sub> /2 - t <sub>SPI_RF</sub>			ns
SCLK Input Pulse-Width High/Low	t <sub>SCH</sub> , t <sub>SCL</sub>			t <sub>SCK</sub> /2		ns
SSEL Active to First Shift Edge	t <sub>SSE</sub>		t <sub>SPI_RF</sub>			ns
MOSI Input to SCLK Sample Edge Rise/Fall Setup	t <sub>SIS</sub>		t <sub>SPI_RF</sub>			ns

## 16-Bit Microcontroller with Infrared Module

### SPI ELECTRICAL CHARACTERISTICS (continued)

(V<sub>DD</sub> = V<sub>RST</sub> to 3.6V, T<sub>A</sub> = 0°C to +70°C, unless otherwise noted.) (Note 11)

PARAMETER	SYMBOL	CONDITIONS	MIN	TYP	MAX	UNITS
MOSI Input from SCLK Sample Edge Transition Hold	t <sub>SIH</sub>		t <sub>SPI_RF</sub>			ns
MISO Output Valid After SCLK Shift Edge Transition	t <sub>SOV</sub>				2t <sub>SPI_RF</sub>	ns
$\overline{\text{SSEL}}$ Inactive	t <sub>SSH</sub>		t <sub>CK</sub> + t <sub>SPI_RF</sub>			ns
SCLK Inactive to $\overline{\text{SSEL}}$ Rising	t <sub>SD</sub>		t <sub>SPI_RF</sub>			ns
MISO Output Disabled After $\overline{\text{SSEL}}$ Edge Rise	t <sub>SLH</sub>				2t <sub>CK</sub> + 2t <sub>SPI_RF</sub>	ns

**Note 1:** Specifications to 0°C are guaranteed by design and are not production tested. Typical = +25°C, V<sub>DD</sub> = +3.3V, unless otherwise noted.

**Note 2:** V<sub>PFW</sub> can be programmed to the following nominal voltage trip points: 1.8V, 1.9V, 2.55V, and 2.75V ±3%. The values listed in the *Recommended Operating Conditions* table are for the default configuration of 1.8V nominal.

**Note 3:** The power-fail reset and POR detectors are designed to operate in tandem to ensure that one or both of these signals is active at all times when V<sub>DD</sub> < V<sub>RST</sub>, ensuring the device maintains the reset state until minimum operating voltage is achieved.

**Note 4:** Guaranteed by design and not production tested.

**Note 5:** Measured on the V<sub>DD</sub> pin and the device not in reset. All inputs are connected to GND or V<sub>DD</sub>. Outputs do not source/sink any current. The device is executing code from flash memory.

**Note 6:** The power-check interval (PCI) can be set to always on, or to 1024, 2048, or 4096 nanopower ring clock cycles.

**Note 7:** Current consumption during POR when powering up while V<sub>DD</sub> is less than the POR release voltage.

**Note 8:** The minimum amount of time that V<sub>DD</sub> must be below V<sub>PFW</sub> before a power-fail event is detected; refer to the *MAXQ610 User's Guide* for details.

**Note 9:** The maximum total current, I<sub>OH(MAX)</sub> and I<sub>OL(MAX)</sub>, for all listed outputs combined should not exceed 32mA to satisfy the maximum specified voltage drop. This does not include the IRTX output.

**Note 10:** Programming time does not include overhead associated with utility ROM interface.

**Note 11:** AC electrical specifications are guaranteed by design and are not production tested.

# MAXQ613

## 16-Bit Microcontroller with Infrared Module

### Pin Configurations

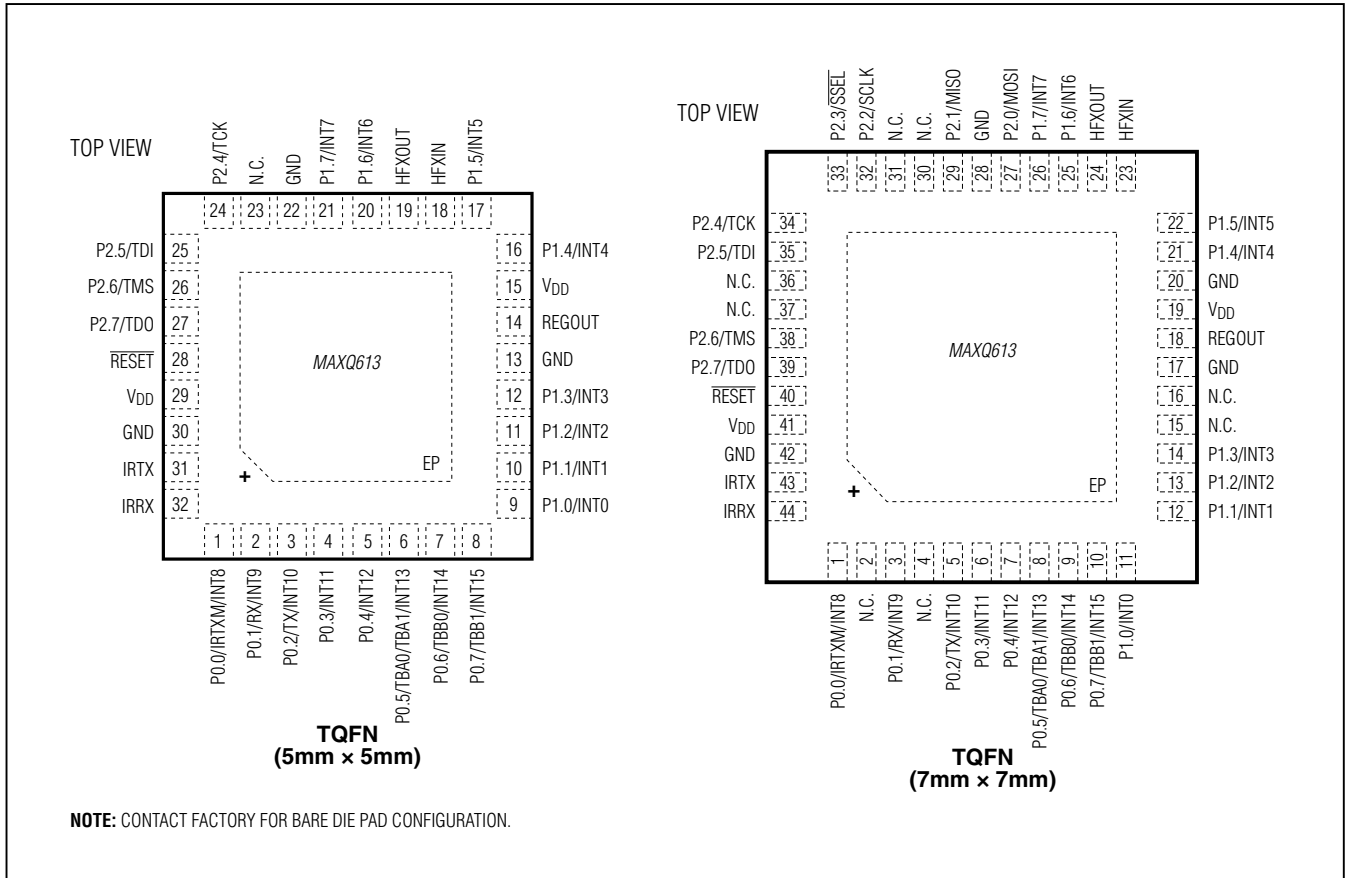

### Pin Description

BARE DIE	PIN		NAME	FUNCTION
	32 TQFN-EP	44 TQFN-EP		
<b>POWER PINS</b>				
15, 36	15, 29	19, 41	V <sub>DD</sub>	Supply Voltage
13, 16, 25, 37	13, 22, 30	17, 20, 28, 42	GND	Ground. Connect directly to the ground plane.
14	14	18	REGOUT	1.8V Regulator Output. This pin must be connected to ground through a 1.0μF external ceramic-chip capacitor. The capacitor must be placed as close to this pin as possible. No devices other than the capacitor should be connected to this pin.

# MAXQ613

## 16-Bit Microcontroller with Infrared Module

### Pin Description (continued)

PIN			NAME	FUNCTION	
BARE DIE	32 TQFN-EP	44 TQFN-EP			
<b>RESET PIN</b>					
35	28	40	$\overline{\text{RESET}}$	Digital, Active-Low, Reset Input/Output. The device remains in reset as long as this pin is low and begins executing from the utility ROM at address 8000h when this pin returns to a high state. The pin includes pullup current source; if this pin is driven by an external device, it should be driven by an open-drain source capable of sinking in excess of 4mA. This pin can be left unconnected if there is no need to place the device in a reset state using an external signal. This pin is driven low as an output when an internal reset condition occurs.	
<b>CLOCK PINS</b>					
20	18	23	HFXIN	High-Frequency Crystal Input. Connect an external crystal or resonator between HFXIN and HFXOUT for use as the high-frequency system clock. Alternatively, HFXIN is the input for an external, high-frequency clock source when HFXOUT is unconnected.	
21	19	24	HFXOUT		
<b>IR FUNCTION PINS</b>					
38	31	43	IRTX	IR Transmit Output. IR transmission pin capable of sinking 25mA. This pin defaults to a high-impedance input with the weak pullup disabled during all forms of reset. Software must configure this pin after release from reset to remove the high-impedance input condition.	
39	32	44	IRRX	IR Receive Input. This pin defaults to a high-impedance input with the weak pullup disabled during all forms of reset. Software must configure this pin after release from reset to remove the high-impedance input condition.	
<b>GENERAL-PURPOSE I/O AND SPECIAL FUNCTION PINS</b>					
				Port 0 General-Purpose, Digital I/O Pins. These port pins function as general-purpose I/O pins with their input and output states controlled by the PD0, PO0, and PIO registers. All port pins default to high-impedance mode after a reset. Software must configure these pins after release from reset to remove the high-impedance condition. All alternate functions must be enabled from software before they can be used.	
				<b>GPIO PORT PIN</b>	<b>SPECIAL FUNCTION</b>
1	1	1	P0.0/IRTXM/ INT8	P0.0	IR Modulator Output/INT8
2	2	3	P0.1/RX/ INT9	P0.1	USART Receive/INT9
3	3	5	P0.2/TX/ INT10	P0.2	USART Transmit/INT10
4	4	6	P0.3/INT11	P0.3	INT11
5	5	7	P0.4/INT12	P0.4	INT12
6	6	8	P0.5/TBA0/ TBA1/INT13	P0.5	Type B Timer 0 Pin A or Type B Timer 1 Pin A/INT13

# MAXQ613

## 16-Bit Microcontroller with Infrared Module

### Pin Description (continued)

BARE DIE	PIN		NAME	FUNCTION	
	32 TQFN-EP	44 TQFN-EP			
7	7	9	P0.6/TBB0/ INT14	P0.6	Type B Timer 0 Pin B/INT14
8	8	10	P0.7/TBB1/ INT15	P0.7	Type B Timer 1 Pin B/INT15
			Port 1 General-Purpose, Digital I/O Pins with Interrupt Capability. These port pins function as general-purpose I/O pins with their input and output states controlled by the PD1, PO1, and PI1 registers. All port pins default to high-impedance mode after a reset. Software must configure these pins after release from reset to remove the high-impedance condition. All external interrupts must be enabled from software before they can be used.		
				<b>GPIO PORT PIN</b>	<b>EXTERNAL INTERRUPT</b>
9	9	11	P1.0/INT0	P1.0	INT0
10	10	12	P1.1/INT1	P1.1	INT1
11	11	13	P1.2/INT2	P1.2	INT2
12	12	14	P1.3/INT3	P1.3	INT3
17	16	21	P1.4/INT4	P1.4	INT4
18	17	22	P1.5/INT5	P1.5	INT5
22	20	25	P1.6/INT6	P1.6	INT6
23	21	26	P1.7/INT7	P1.7	INT7
			Port 2 General-Purpose, Digital I/O Pins. These port pins function as general-purpose I/O pins with their input and output states controlled by the PD2, PO2, and PI2 registers. All port pins default to high-impedance mode after a reset. Software must configure these pins after release from reset to remove the high-impedance condition. All special functions must be enabled from software before they can be used.		
				<b>GPIO PORT PIN</b>	<b>SPECIAL FUNCTION</b>
24	—	27	P2.0/MOSI	P2.0	SPI: Master Out-Slave In
26	—	29	P2.1/MISO	P2.1	SPI: Master In-Slave Out
28	—	32	P2.2/SCLK	P2.2	SPI: Slave Clock
30	—	33	P2.3/SSEL	P2.3	SPI: Active-Low Slave Select
31	24	34	P2.4/TCK	P2.4	JTAG: Test Clock
32	25	35	P2.5/TDI	P2.5	JTAG: Test Data In
33	26	38	P2.6/TMS	P2.6	JTAG: Test Mode Select
34	27	39	P2.7/TDO	P2.7	JTAG: Test Data Out
<b>NO CONNECTION PINS</b>					
—	23	2, 4, 15, 16, 30, 31, 36, 37	N.C.	No Connection. Not internally connected.	
—	—	—	EP	Exposed Pad. Connect EP directly to the ground plane.	

# MAXQ613

## 16-Bit Microcontroller with Infrared Module

### Block Diagram

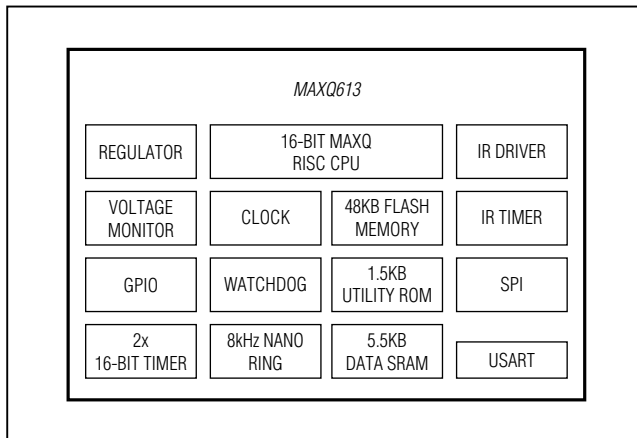

### Detailed Description

The MAXQ613 provides integrated, low-cost solutions that simplify the design of IR communications equipment such as universal remote controls. Standard features include the highly optimized, single-cycle, MAXQ, 16-bit RISC core; 48KB of program flash memory; 1.5KB data RAM; soft stack; 16 general-purpose registers; and three data pointers. The MAXQ core has the industry's best MIPS/mA rating, allowing developers to achieve the same performance as competing microcontrollers at substantially lower clock rates. Lower active-mode current combined with the even lower MAXQ613 stop-mode current (0.2µA typ) results in increased battery life. Application-specific peripherals include flexible timers for generating IR carrier frequencies and modulation. A high-current IR drive pin capable of sinking up to 25mA current and output pins capable of sinking up to 5mA are ideal for IR applications. It also includes general-purpose I/O pins ideal for keypad matrix input, and a power-fail-detection circuit to notify the application when the supply voltage is nearing the microcontroller's minimum operating voltage.

At the heart of the device is the MAXQ 16-bit, RISC core. Operating from DC to 12MHz, almost all instructions execute in a single clock cycle (83.3ns at 12MHz), enabling nearly 12MIPS true-code operation. When active device operation is not required, an ultra-low-power stop mode

can be invoked from software, resulting in quiescent current consumption of less than 0.2µA (typ) and 2.0µA (max). The combination of high-performance instructions and ultra-low stop-mode current increases battery life over competing microcontrollers. An integrated POR circuit with brownout support resets the device to a known condition following a power-up cycle or brownout condition. Additionally, a power-fail warning flag is set, and a power-fail interrupt can be generated when the system voltage falls below the power-fail warning voltage,  $V_{PFW}$ . The power-fail warning feature allows the application to notify the user that the system supply is low and appropriate action should be taken.

### Microprocessor

The device is based on Maxim's low-power, 16-bit MAXQ20S family of RISC cores. The core supports the Harvard memory architecture with separate 16-bit program and data address buses. A fixed 16-bit instruction word is standard, but data can be arranged in 8 or 16 bits. The MAXQ core in the device is implemented as a pipelined processor with performance approaching 1MIPS per MHz. The 16-bit data path is implemented around register modules, and each register module contributes specific functions to the core. The accumulator module consists of sixteen 16-bit registers and is tightly coupled with the arithmetic logic unit (ALU). A configurable soft stack supports program flow.

Execution of instructions is triggered by data transfer between functional register modules or between a functional register module and memory. Because data movement involves only source and destination modules, circuit switching activities are limited to active modules only. For power-conscious applications, this approach localizes power dissipation and minimizes switching noise. The modular architecture also provides a maximum of flexibility and reusability that are important for a microprocessor used in embedded applications.

The MAXQ instruction set is highly orthogonal. All arithmetical and logical operations can use any register in conjunction with the accumulator. Data movement is supported from any register to any other register. Memory is accessed through specific data-pointer registers with autoincrement/decrement support.

# MAXQ613

## 16-Bit Microcontroller with Infrared Module

### Memory

The microcontroller incorporates several memory types:

- 48KB program flash memory
- 1.5KB SRAM data memory
- 5.5KB utility ROM
- Soft stack

### Memory Protection

The optional memory-protection feature separates code memory into three areas: system, user loader, and user application. Code in the system area can be kept confidential. Code in the user areas can be prevented from reading and writing system code. The user loader can also be protected from user application code.

Memory protection is implemented using privilege levels for code. Each area has an associated privilege level. RAM/ROM are assigned privilege levels as well. Refer to the *MAXQ610 User's Guide* for a more thorough explanation of the topic. See Table 1.

### Stack Memory

The device provides a soft stack that can be used to store program return addresses (for subroutine calls and interrupt handling) and other general-purpose data. This soft stack is located in the 1.5KB SRAM data memory, which means that the SRAM data memory must be shared between the soft stack and general-purpose application data storage. However, the location and size of the soft stack is determined by the user, providing maximum flexibility when allocating resources for a particular application. The stack is used automatically by the processor when the CALL, RET, and RETI instructions are executed and when an interrupt is serviced. An application can also store and retrieve values explicitly using the stack by means of the PUSH, POP, and POP1 instructions.

The SP pointer indicates the current top of the stack, which initializes by default to the top of the SRAM data memory. As values are pushed onto the stack, the SP pointer decrements, which means that the stack grows downward towards the bottom (lowest address) of the data memory. Popping values off the stack causes the SP pointer value to increase. Refer to the *MAXQ610 User's Guide* for more details.

### Utility ROM

The utility ROM is a 5.5KB block of internal ROM memory located in program space beginning at address 8000h. This ROM includes the following routines:

- In-system programming (bootstrap loader) using JTAG interface
- In-circuit debugging routines using JTAG interface
- Production test routines (internal memory tests, memory loader, etc.), which are used for internal testing only, and are generally of no use to the end-application developer
- User-callable routines for in-application flash programming, buffer copying, and fast table lookup (more information on these routines can be found in the *MAXQ610 User's Guide*)

Following any reset, execution begins in the utility ROM at address 8000h. At this point, unless loader mode or test mode has been invoked (which requires special programming through the JTAG interface), the utility ROM in the device always automatically jumps to location 0000h, which is the beginning of user application code in program flash memory.

Some applications require protection against unauthorized viewing of program code memory. For these applications, access to in-system programming, in-application programming, or in-circuit debugging functions is prohibited until a password has been supplied. Three

**Table 1. Memory Areas and Associated Maximum Privilege Levels**

AREA	PAGE ADDRESS	MAXIMUM PRIVILEGE LEVEL
System	0 to ULDR-1	High
User Loader	ULDR to UAPP-1	Medium
User Application	UAPP to top	Low
Utility ROM	N/A	High
Other (RAM)	N/A	Low

**16-Bit Microcontroller with Infrared Module****Table 2. Watchdog Interrupt Timeout (Sysclk = 12MHz, CD[1:0] = 00)**

WD[1:0]	WATCHDOG CLOCK	WATCHDOG INTERRUPT TIMEOUT	WATCHDOG RESET AFTER WATCHDOG INTERRUPT (μs)
00	Sysclk/2 <sup>15</sup>	2.7ms	42.7
01	Sysclk/2 <sup>18</sup>	21.9ms	42.7
10	Sysclk/2 <sup>21</sup>	174.7ms	42.7
11	Sysclk/2 <sup>24</sup>	1.4s	42.7

different password locks are provided, each of which can be used to protect a different area of memory (system memory, user loader, and user application). Each password lock is controlled by a 16-word area of flash memory; if the password is set to all FFFFh values or all 0000h values, the password is disabled. Otherwise, the password is active and must be matched by the user of the bootloader or debugger before access is granted to the corresponding area of flash program memory. Refer to the *MAXQ610 User's Guide* for more details.

### **Watchdog Timer**

The internal watchdog timer greatly increases system reliability. The timer resets the device if software execution is disturbed. The watchdog timer is a free-running counter designed to be periodically reset by the application software. If software is operating correctly, the counter is periodically reset and never reaches its maximum count. However, if software operation is interrupted, the timer does not reset, triggering a system reset and optionally a watchdog timer interrupt. This protects the system against electrical noise or electrostatic discharge (ESD) upsets that could cause uncontrolled processor operation. The internal watchdog timer is an upgrade to older designs with external watchdog devices, reducing system cost and simultaneously increasing reliability.

The watchdog timer functions as the source of both the watchdog timer timeout and the watchdog timer reset. The timeout period can be programmed in a range of 2<sup>15</sup> to 2<sup>24</sup> system clock cycles. An interrupt is generated when the timeout period expires if the interrupt is enabled. All watchdog timer resets follow the programmed interrupt timeouts by 512 system clock cycles. If the watchdog timer is not restarted for another full interval in this time period, a system reset occurs when the reset timeout expires. See Table 2.

### **IR Carrier Generation and Modulation Timer**

The dedicated IR timer/counter module simplifies low-speed infrared (IR) communication. The IR timer implements two pins (IRTX and IRRX) for supporting IR transmit and receive, respectively. The IRTX pin has no corresponding port pin designation, so the standard PD, PO, and PI port control status bits are not present. However, the IRTX pin output can be manipulated high or low using the PWCN.IRTXOUT and PWCN.IRTXOE bits when the IR timer is not enabled (i.e., IREN = 0).

The IR timer is composed of a carrier generator and a carrier modulator. The carrier generation module uses the 16-bit IR carrier register (IRCA) to define the high and low time of the carrier through the IR carrier high byte (IRCAH) and IR carrier low byte (IRCAL). The carrier modulator uses the IR data bit (IRDATA) and IR modulator time register (IRMT) to determine whether the carrier or the idle condition is present on IRTX.

The IR timer is enabled when the IR enable bit (IREN) is set to 1. The IR Value register (IRV) defines the beginning value for the carrier modulator. During transmission, the IRV register is initially loaded with the IRMT value and begins down counting towards 0000h, whereas in receive mode it counts upward from the initial IRV register value. During the receive operation, the IRV register can be configured to reload with 0000h when capture occurs on detection of selected edges or can be allowed to continue free-running throughout the receive operation. An overflow occurs when the IR timer value rolls over from 0FFFFh to 0000h. The IR overflow flag (IROV) is set to 1 and an interrupt is generated if enabled (IRIE = 1).

# MAXQ613

## 16-Bit Microcontroller with Infrared Module

### Carrier Generation Module

The IRCAH byte defines the carrier high time in terms of the number of IR input clocks, whereas the IRCAL byte defines the carrier low time.

- IR Input Clock ( $f_{IRCLK}$ ) =  $f_{SYS}/2^{IRDIV[2:0]}$
- Carrier Frequency ( $f_{CARRIER}$ ) =  $f_{IRCLK}/(IRCAH + IRCAL + 2)$
- Carrier High Time =  $IRCAH + 1$
- Carrier Low Time =  $IRCAL + 1$
- Carrier Duty Cycle =  $(IRCAH + 1)/(IRCAH + IRCAL + 2)$

During transmission, the IRCA register is latched for each IRV down-count interval, and is sampled along with the IRTXPOL and IRDATA bits at the beginning of each new IRV down-count interval so that duty-cycle variation and frequency shifting is possible from one interval to the next, which is illustrated in Figure 1.

Figure 2 illustrates the basic carrier generation and its path to the IRTX output pin. The IR transmit polarity bit (IRTXPOL) defines the starting/idle state and the carrier polarity of the IRTX pin when the IR timer is enabled.

### IR Transmission

During IR transmission (IRMODE = 1), the carrier generator creates the appropriate carrier waveform, while the carrier modulator performs the modulation. The carrier modulation can be performed as a function of carrier cycles or IRCLK cycles dependent on the setting of the IRCFME bit. When IRCFME = 0, the IRV down counter is clocked by the carrier frequency and thus the modulation is a function of carrier cycles. When IRCFME = 1, the IRV down counter is clocked by IRCLK, allowing carrier modulation timing with IRCLK resolution.

The IRTXPOL bit defines the starting/idle state as well as the carrier polarity for the IRTX pin. If IRTXPOL = 1, the

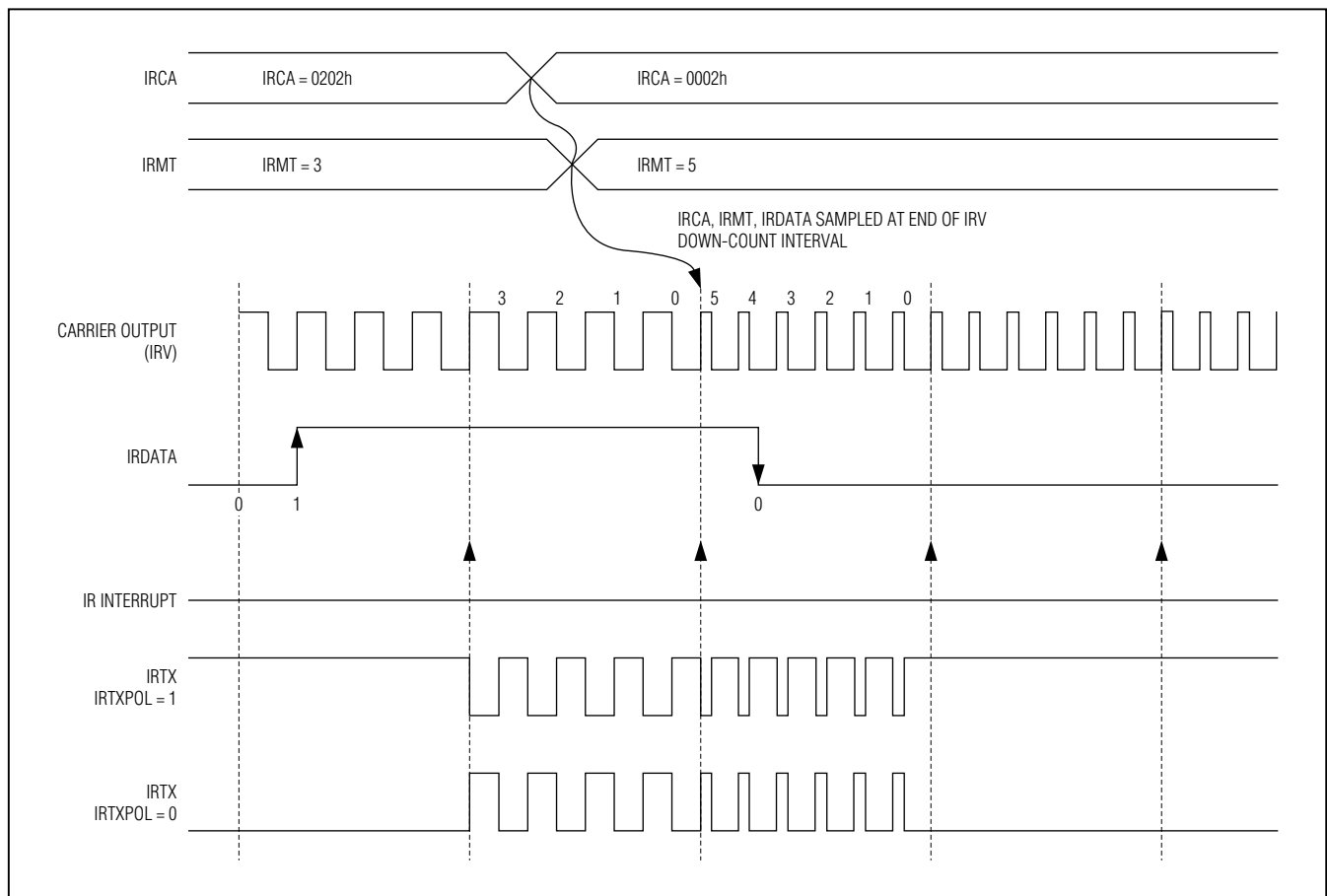

Figure 1. IR Transmit Frequency Shifting Example (IRCFME = 0)

## 16-Bit Microcontroller with Infrared Module

IRTX pin is set to a logic-high when the IR timer module is enabled. If IRTXPOL = 0, the IRTX pin is set to a logic-low when the IR timer is enabled.

A separate register bit, IR data (IRDATA), is used to determine whether the carrier generator output is output to the IRTX pin for the next IRMT carrier cycles. When IRDATA = 1, the carrier waveform (or inversion of this waveform if IRTXPOL = 1) is output on the IRTX pin during the next IRMT cycles. When IRDATA = 0, the idle

condition, as defined by IRTXPOL, is output on the IRTX pin during the next IRMT cycles.

The IR timer acts as a down counter in transmit mode. An IR transmission starts when the IREN bit is set to 1 when IRMODE = 1; when the IRMODE bit is set to 1 when IREN = 1; or when IREN and IRMODE are both set to 1 in the same instruction. The IRMT and IRCA registers, along with the IRDATA and IRTXPOL bits, are sampled at the beginning of the transmit process and every time the IR

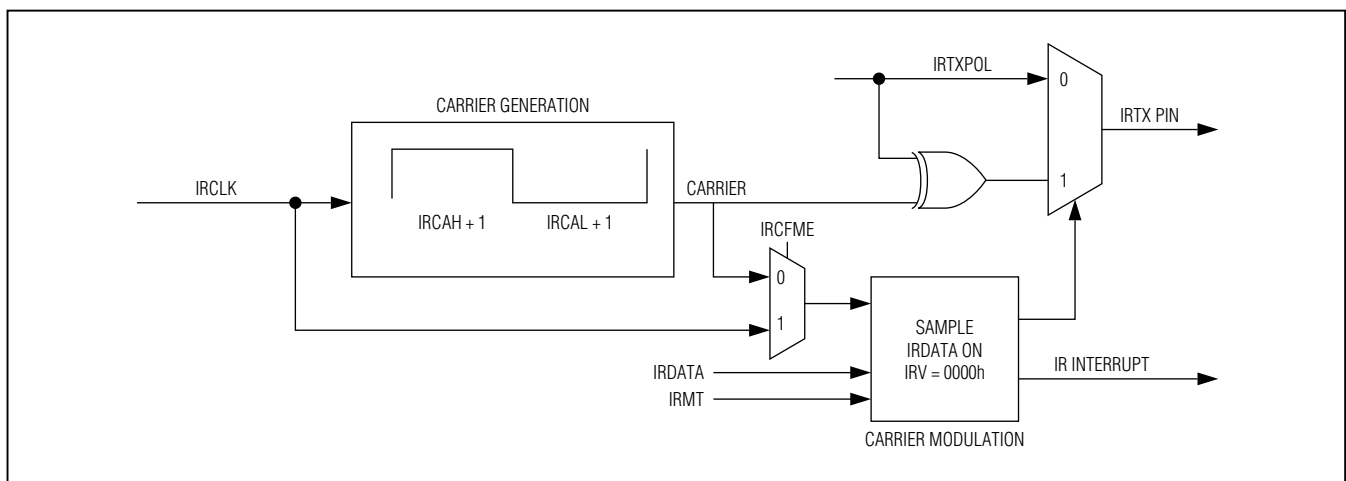

Figure 2. IR Transmit Carrier Generation and Carrier Modulator Control

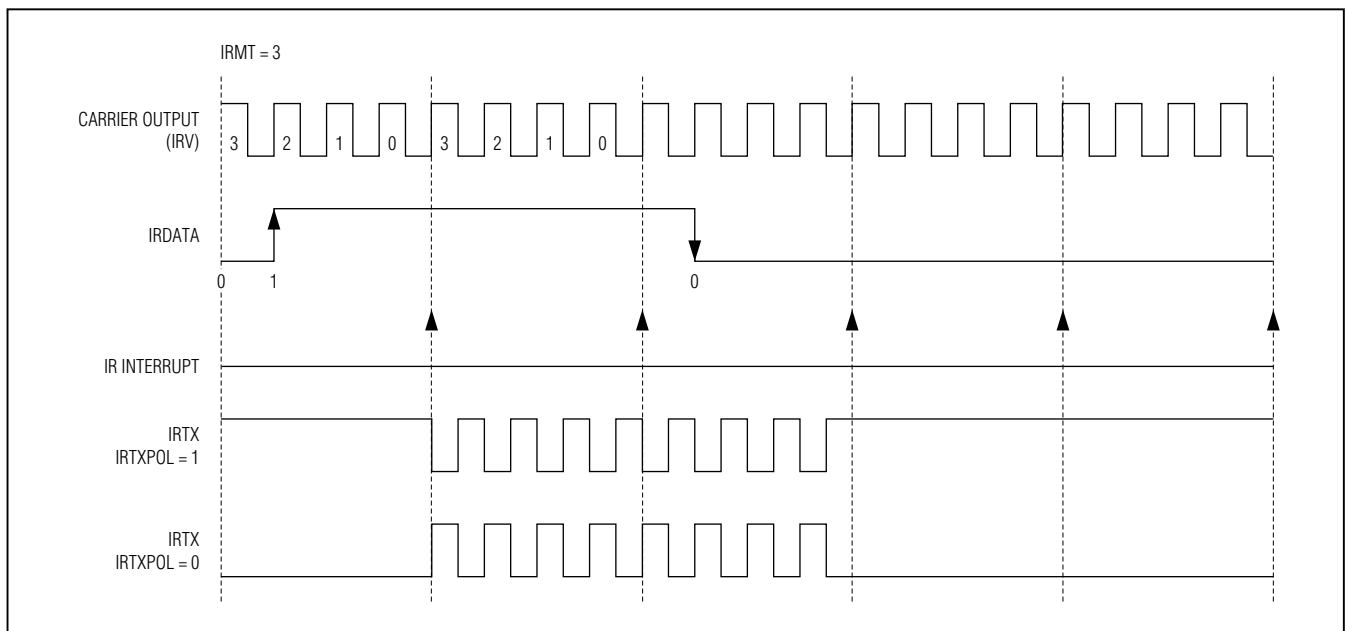

Figure 3. IR Transmission Waveform (IRCFME = 0)

# MAXQ613

## 16-Bit Microcontroller with Infrared Module

timer value reloads its value. When the IRV reaches 0000h value, on the next carrier clock, it does the following:

- 1) Reloads IRV with IRMT.
- 2) Samples IRCA, IRDATA, and IRTXPOL.
- 3) Generates IRTX accordingly.
- 4) Sets IRIF to 1.
- 5) Generates an interrupt to the CPU if enabled (IRIE = 1).

To terminate the current transmission, the user can switch to receive mode (IRMODE = 0) or clear IREN to 0.

$$\text{Carrier Modulation Time} = \text{IRMT} + 1 \text{ carrier cycles}$$

### IR Transmit—Independent External Carrier and Modulator Outputs

The normal transmit mode modulates the carrier based upon the IRDATA bit. However, the user has the option to input the modulator (envelope) on an external pin if desired. If the IRENV[1:0] bits are configured to 01b or 10b, the modulator/envelope is output to the IRTXM pin. The IRDATA bit is output directly to the IRTXM pin (if IRTXPOL = 0) on each IRV down-count interval boundary just as if it were being used to internally modulate the carrier frequency. If IRTXPOL = 1, the inverse of the IRDATA bit is output to the IRTXM pin on the IRV interval down-count boundaries. See Figure 4. When the envelope mode is enabled, it is possible to output either the modulated (IRENV[1:0] = 01b) or unmodulated (IRENV[1:0] = 10b) carrier to the IRTX pin.

### IR Receive

When configured in receive mode (IRMODE = 0), the IR hardware supports the IRRX capture function. The IRRXSEL[1:0] bits define which edge(s) of the IRRX pin should trigger the IR timer capture function.

The IR module starts operating in the receive mode when IRMODE = 0 and IREN = 1. Once started, the IR timer (IRV) starts up counting from 0000h when a qualified capture event as defined by IRRXSEL happens. The IRV register is, by default, counting carrier cycles as defined by the IRCA register. However, the IR carrier frequency detect (IRCFME) bit can be set to 1 to allow clocking of the IRV register directly with the IRCLK for finer resolution. When IRCFME = 0, the IRCA defined carrier is counted by IRV. When IRCFME = 1, the IRCLK clocks the IRV register.

On the next qualified event, the IR module does the following:

- 1) Captures the IRRX pin state and transfers its value to IRDATA. If a falling edge occurs, IRDATA = 0. If a rising edge occurs, IRDATA = 1.
- 2) Transfers its current IRV value to the IRMT.
- 3) Resets IRV content to 0000h (if IRXRL = 1).
- 4) Continues counting again until the next qualified event.

If the IR timer value rolls over from 0FFFFh to 0000h before a qualified event happens, the IR timer overflow (IROV) flag is set to 1 and an interrupt is generated, if

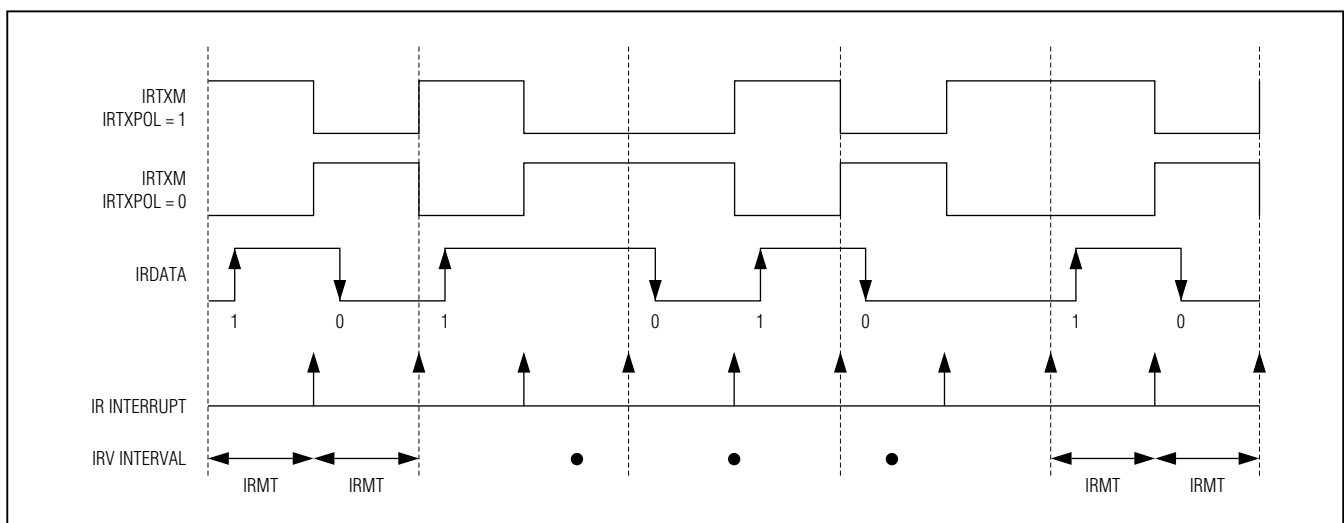

Figure 4. External IRTXM (Modulator) Output

## 16-Bit Microcontroller with Infrared Module

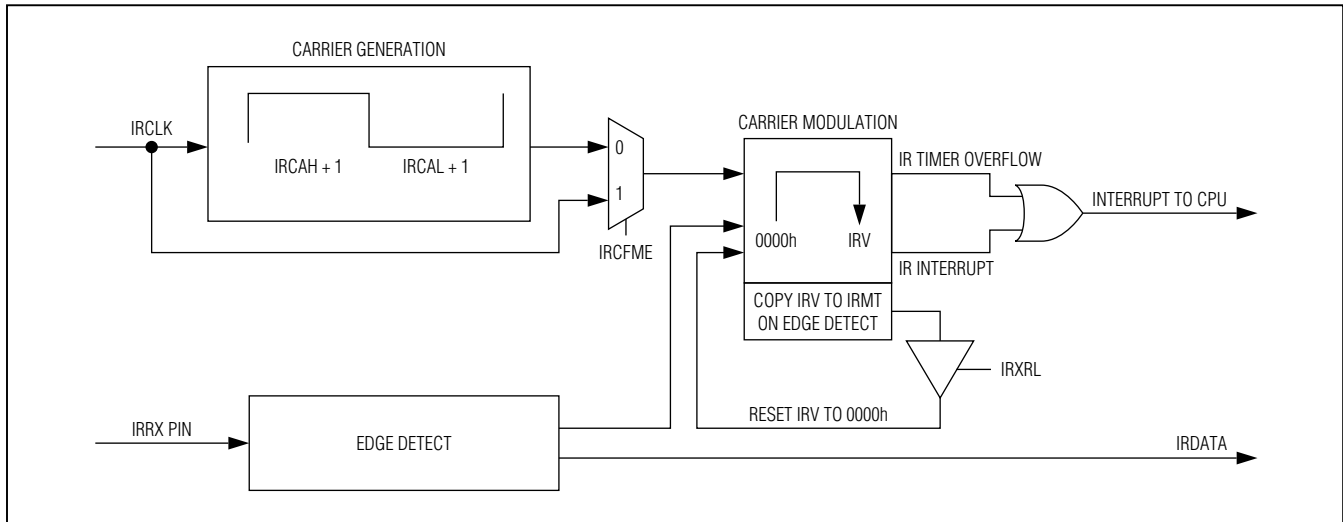

Figure 5. IR Capture

enabled. The IR module continues to operate in receive mode until it is stopped by switching into transmit mode (IRMODE = 1) or clearing IREN = 0.

### Carrier Burst-Count Mode

A special mode reduces the CPU processing burden when performing IR learning functions. Typically, when operating in an IR learning capacity, some number of carrier cycles are examined for frequency determination. Once the frequency has been determined, the IR receive function can be reduced to counting the number of carrier pulses in the burst and the duration of the combined mark-space time within the burst. To simplify this process, the receive burst-count mode (as enabled by the RXBCNT bit) can be used. When RXBCNT = 0, the standard IR receive capture functionality is in place. When RXBCNT = 1, the IRV capture operation is disabled and the interrupt flag associated with the capture no longer denotes a capture. In the carrier burst-count mode, the IRMT register only counts qualified edges. The IRIF interrupt flag (normally used to signal a capture when RXBCNT = 0) now becomes set if two IRCA cycles elapse without getting a qualified edge. The IRIF interrupt flag thus denotes absence of the carrier and the beginning of a space in the receive signal. When the RXBCNT bit is changed from 0 to 1, the IRMT register is set to 0001h. The IRCFME bit is still used to define whether the IRV register is counting system IRCLK clocks or IRCA-defined carrier cycles. The IRXRL bit defines whether the IRV register is reloaded with 0000h on detection of a qualified edge (per the IRXSEL[1:0] bits). Figure 6 and the descriptive sequence embedded

in the figure illustrate the expected usage of the receive burst-count mode.

### 16-Bit Timers/Counters

The microcontroller provides two timers/counters that support the following functions:

- 16-bit timer/counter
- 16-bit up/down autoreload
- Counter function of external pulse
- 16-bit timer with capture
- 16-bit timer with compare
- Input/output enhancements for pulse-width modulation
- Set/reset/toggle output state on comparator match
- Prescaler with 2<sup>n</sup> divider (for n = 0, 2, 4, 6, 8, 10)

### USART

The device provides a USART peripheral with the following features:

- 2-wire interface
- Full-duplex operation for asynchronous data transfers
- Half-duplex operation for synchronous data transfers
- Programmable interrupt when transmit or receive data operation completes
- Independent programmable baud-rate generator
- Optional 9th bit parity support
- Start/stop bit support

# MAXQ613

## 16-Bit Microcontroller with Infrared Module

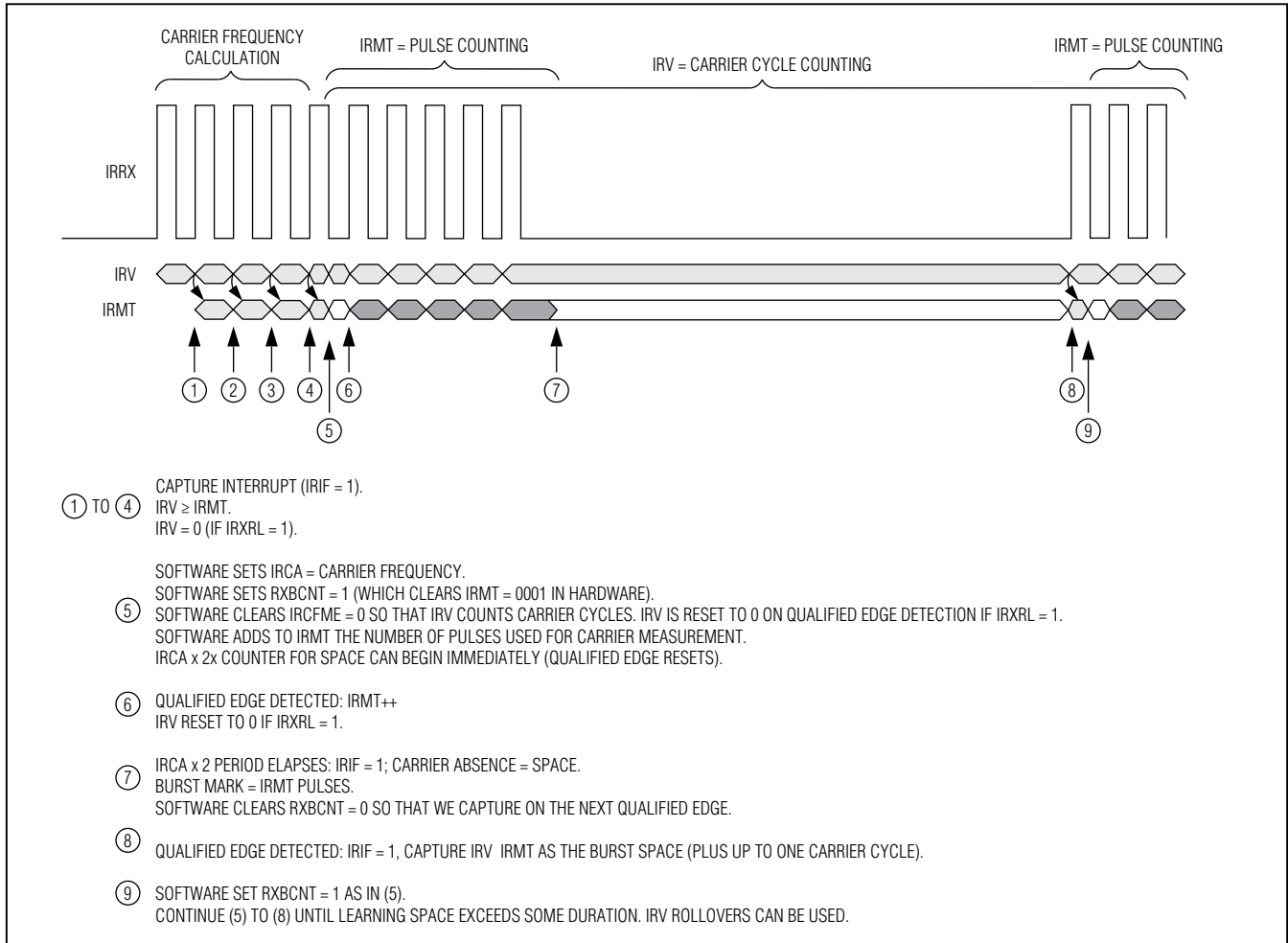

Figure 6. Receive Burst-Count Example

**Table 3. USART Mode Details**

MODE	TYPE	START BITS	DATA BITS	STOP BITS
Mode 0	Synchronous	N/A	8	N/A
Mode 1	Asynchronous	1	8	1
Mode 2	Asynchronous	1	8 + 1	1
Mode 3	Asynchronous	1	8 + 1	1

### Serial Peripheral Interface (SPI)

The integrated SPI provides an independent serial communication channel that communicates synchronously with peripheral devices in a multiple master or multiple slave system. The interface allows access to a 4-wire, full-duplex serial bus, and can be operated in either master mode or slave mode. Collision detection

is provided when two or more masters attempt a data transfer at the same time.

The maximum SPI master transfer rate is Sysclk/2. When operating as an SPI slave, the device can support up to Sysclk/4 SPI transfer rate. Data is transferred as an 8-bit or 16-bit value, MSB first. In addition, the SPI module supports configuration of an active  $\overline{SSEL}$  state (active low or active high) through the slave active select.

## 16-Bit Microcontroller with Infrared Module

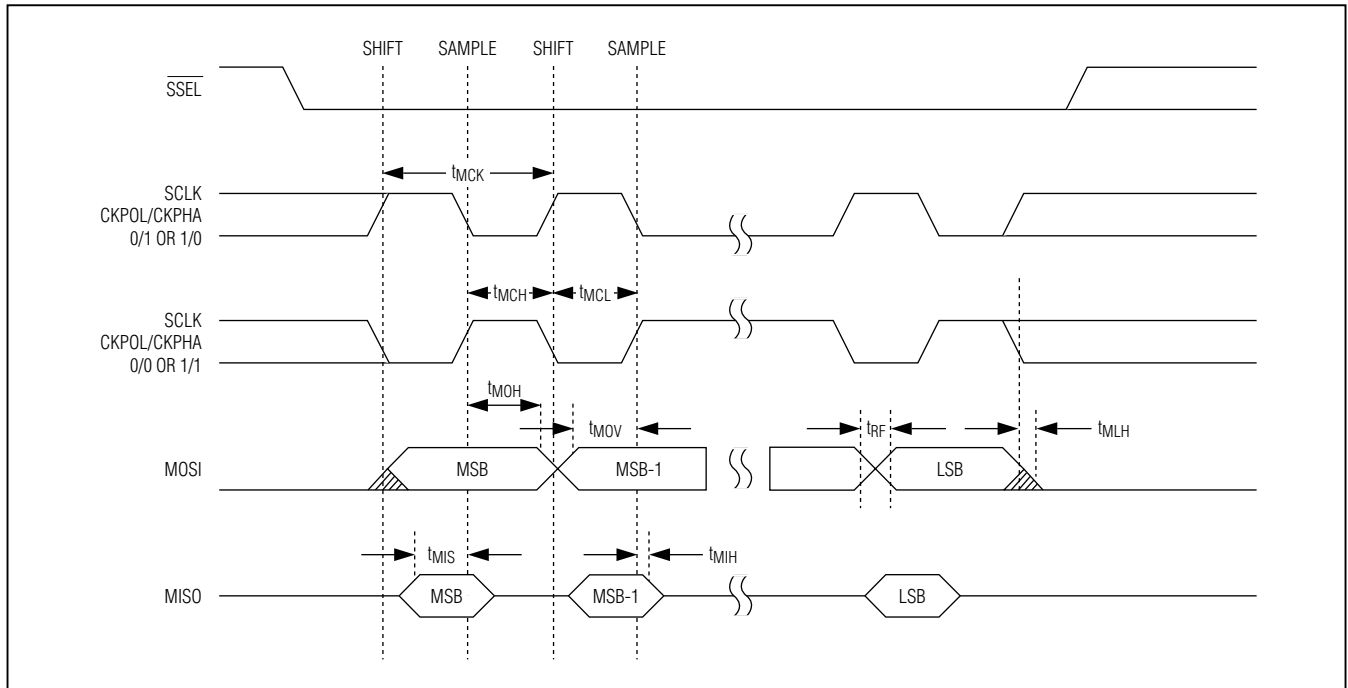

Figure 7. SPI Master Communication Timing

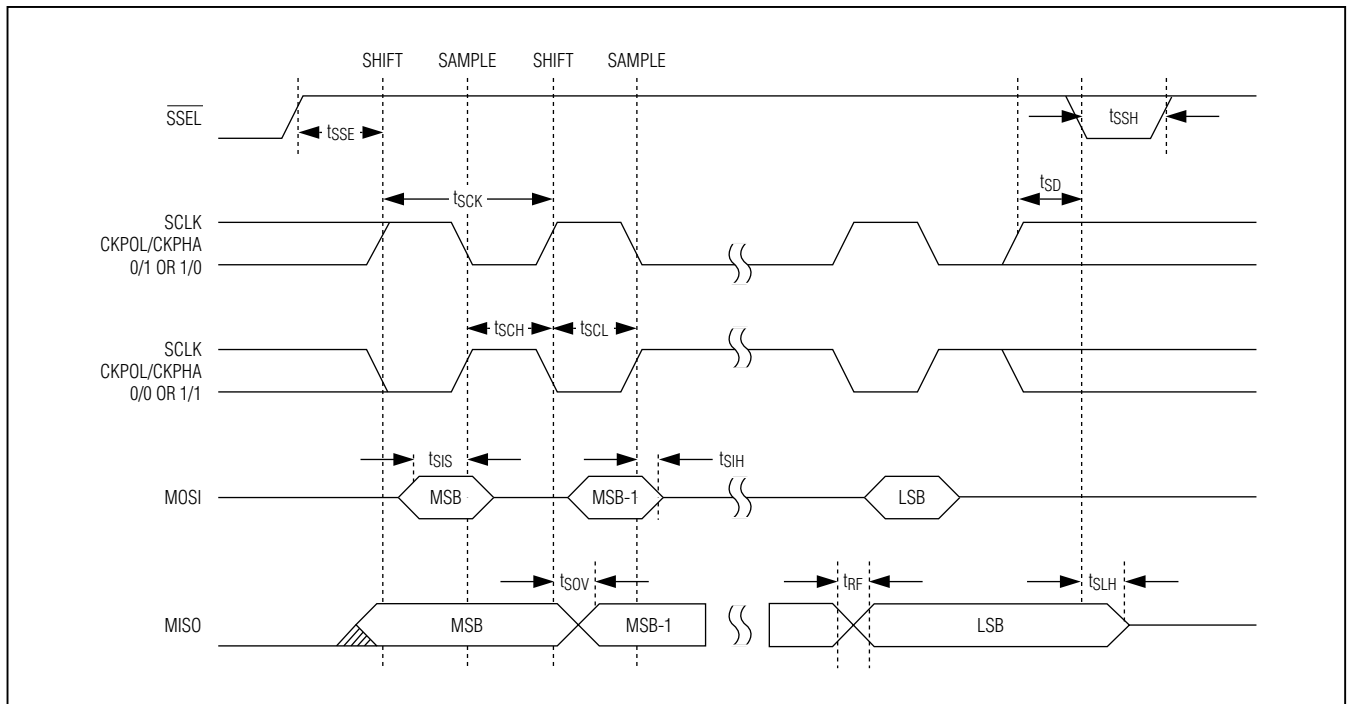

Figure 8. SPI Slave Communication Timing

# MAXQ613

## 16-Bit Microcontroller with Infrared Module

### General-Purpose I/O

The microcontroller provides port pins for general-purpose I/O that have the following features:

- CMOS output drivers
- Schmitt trigger inputs
- Optional weak pullup to  $V_{DD}$  when operating in input mode

While the microcontroller is in a reset state, all port pins become high impedance with both weak pullups and input buffers disabled, unless otherwise noted.

From a software perspective, each port appears as a group of peripheral registers with unique addresses. Special function pins can also be used as general-purpose I/O pins when the special functions are disabled. For a detailed description of the special functions available for each pin, refer to the *MAXQ610 User's Guide*.

### On-Chip Oscillator

An external quartz crystal or a ceramic resonator can be connected between HFXIN and HFXOUT, as illustrated in Figure 9.

Noise at HFXIN and HFXOUT can adversely affect on-chip clock timing. It is good design practice to place the crystal and capacitors near the oscillator circuitry and connect HFXIN and HFXOUT to ground with a direct short trace. The typical values of external capacitors vary with the type of crystal to be used and should be initially selected based on load capacitance as suggested by the manufacturer.

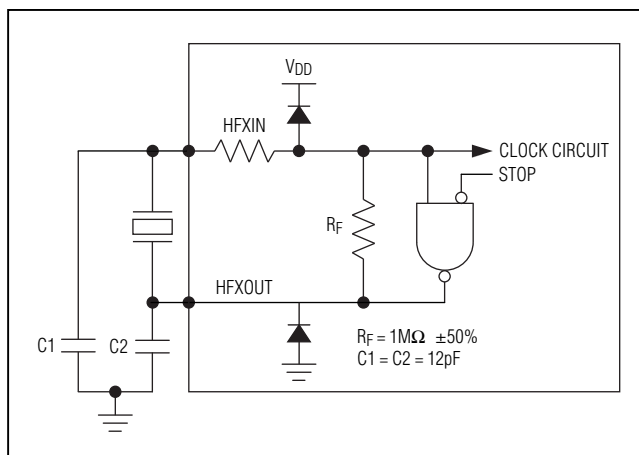

Figure 9. On-Chip Oscillator

### ROM Loader

The ROM loader denies access to the system, user loader, or user-application memories unless an area-specific password is provided. The ROM loader is not available in ROM-only versions.

### Loading Flash Memory

An internal bootstrap loader allows reloading over a simple JTAG interface. As a result, software can be upgraded in-system, eliminating the need for a costly hardware retrofit when updates are required. Remote software uploads are possible that enable physically inaccessible applications to be frequently updated. The interface hardware can be a JTAG connection to another microcontroller, or a connection to a PC serial port using a serial-to-JTAG converter such as the MAXQJTAG-001, available from Maxim. If in-system programmability is not required, a commercial gang programmer can be used for mass programming. Activating the JTAG interface and loading the test access port (TAP) with the system programming instruction invokes the bootstrap loader. Setting the SPE bit to one during reset through the JTAG interface executes the bootstrap-loader mode program that resides in the utility ROM. When programming is complete, the bootstrap loader can clear the SPE bit and reset the device, allowing the device to bypass the utility ROM and begin execution of the application software.

In addition, the ROM loader also enforces the memory-protection policies. Passwords that are 16 words are required to access the ROM loader interface.

Loading memory is not possible for ROM-only versions of the device.

### In-Application Flash Programming

From user-application code, flash memory can be programmed using the ROM utility functions from either C or assembly language. The function declarations below show examples of some of the ROM utility functions provided for in-application flash memory programming:

```
/* Write one 16-bit word to code address 'dest'.
 * Dest must be aligned to 16 bits.
 * Returns 0 = failure, 1 = OK.
 */
int flash_write (uint16_t dest, uint16_t
data);
```

## 16-Bit Microcontroller with Infrared Module

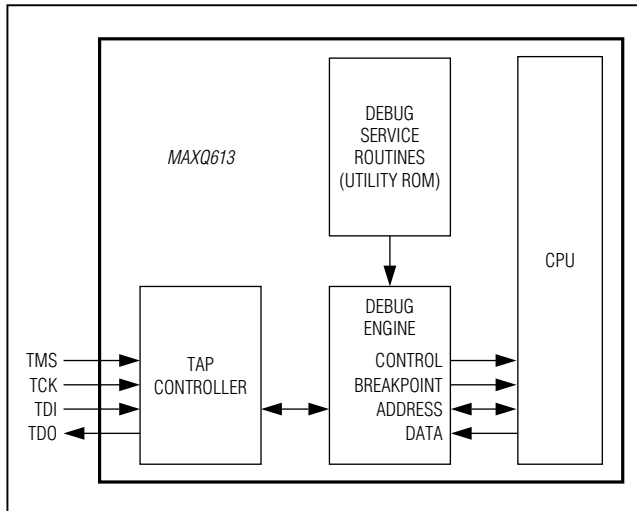

Figure 10. In-Circuit Debugger

To erase, the following function would be used:

```
/* Erase the given Flash page
 * addr: Flash offset (anywhere within page)
 */
int flash_erasepage(uint16_t addr);
```

The in-application flash memory programming must call ROM utility functions to erase and program any of the flash memory. Memory protection is enforced by the ROM utility functions. In-application is not available in ROM-only versions of the device.

### **In-Circuit Debug and JTAG Interface**

Embedded debug hardware and software are developed and integrated to provide full in-circuit debugging capability in a user-application environment. These hardware and software features include the following:

- Debug engine
- Set of registers providing the ability to set breakpoints on register, code, or data using debug service routines stored in ROM

Collectively, these hardware and software features support two modes of in-circuit debug functionality:

- Background mode:
  - CPU is executing the normal user program
  - Allows the host to configure and set up the in-circuit debugger

- Debug mode:
  - Debugger takes over the control of the CPU
  - Read/write accesses to internal registers and memory
  - Single-step of the CPU for trace operation

The interface to the debug engine is the TAP controller. The interface allows for communication with a bus master that can either be automatic test equipment or a component that interfaces to a higher level test bus as part of a complete system. The communication operates across a 4-wire serial interface from a dedicated TAP that is compatible with the JTAG IEEE Standard 1149. The TAP provides an independent serial channel to communicate synchronously with the host system.

To prevent unauthorized access of the protected memory regions through the JTAG interface, the debug engine prevents modification of the privilege registers and disallows all access to system memory, unless memory protection is disabled. In addition, all services (such as register display or modification) are denied when code is executing inside the system area. The debugger is not available for ROM-only versions of the device.

### **Operating Modes**

The lowest power mode of operation is stop mode. In this mode, CPU state and memories are preserved, but the CPU is not actively running. Wake-up sources include external I/O interrupts, the power-fail warning interrupt, wake-up timer, or a power-fail reset. Any time the microcontroller is in a state where code does not need to be executed, the user software can put the device into stop mode. The nanopower ring oscillator is an internal ultra-low-power (400nA) 8kHz ring oscillator that can be used to drive a wake-up timer that exits stop mode. The wake-up timer is programmable by software in steps of 125µs up to approximately 8s.

The power-fail monitor is always on during normal operation. However, it can be selectively disabled during stop mode to minimize power consumption. This feature is enabled using the power-fail monitor disable (PFD) bit in the PWCN register. The reset default state for the PFD bit is 1, which disables the power-fail monitor function during stop mode. If power-fail monitoring is disabled (PFD = 1) during stop mode, the circuitry responsible for generating a power-fail warning or reset is shut down and neither condition is detected. Thus, the  $V_{DD} < V_{RST}$  condition does not invoke a reset state.

# MAXQ613

## 16-Bit Microcontroller with Infrared Module

### Power-Fail Detection

Figures 11, 12, and 13 show the power-fail detection and response during normal and stop-mode operation. If a reset is caused by a power-fail, the power-fail monitor can be set to one of the following intervals:

- Always on—continuous monitoring
- 2<sup>11</sup> nanopower ring oscillator clocks (~256ms)
- 2<sup>12</sup> nanopower ring oscillator clocks (~512ms)
- 2<sup>13</sup> nanopower ring oscillator clocks (~1.024s)

In the case where the power-fail circuitry is periodically turned on, the power-fail detection is turned on for two

nANopower ring-oscillator cycles. If  $V_{DD} > V_{RST}$  during detection,  $V_{DD}$  is monitored for an additional nanopower ring-oscillator period. If  $V_{DD}$  remains above  $V_{RST}$  for the third nanopower ring period, the CPU exits the reset state and resumes normal operation from utility ROM at 8000h after satisfying the crystal warmup period.

If a reset is generated by any other event, such as the  $\overline{RESET}$  pin being driven low externally or the watchdog timer, the power-fail, internal regulator, and crystal remain on during the CPU reset. In these cases, the CPU exits the reset state in less than 20 crystal cycles after the reset source is removed.

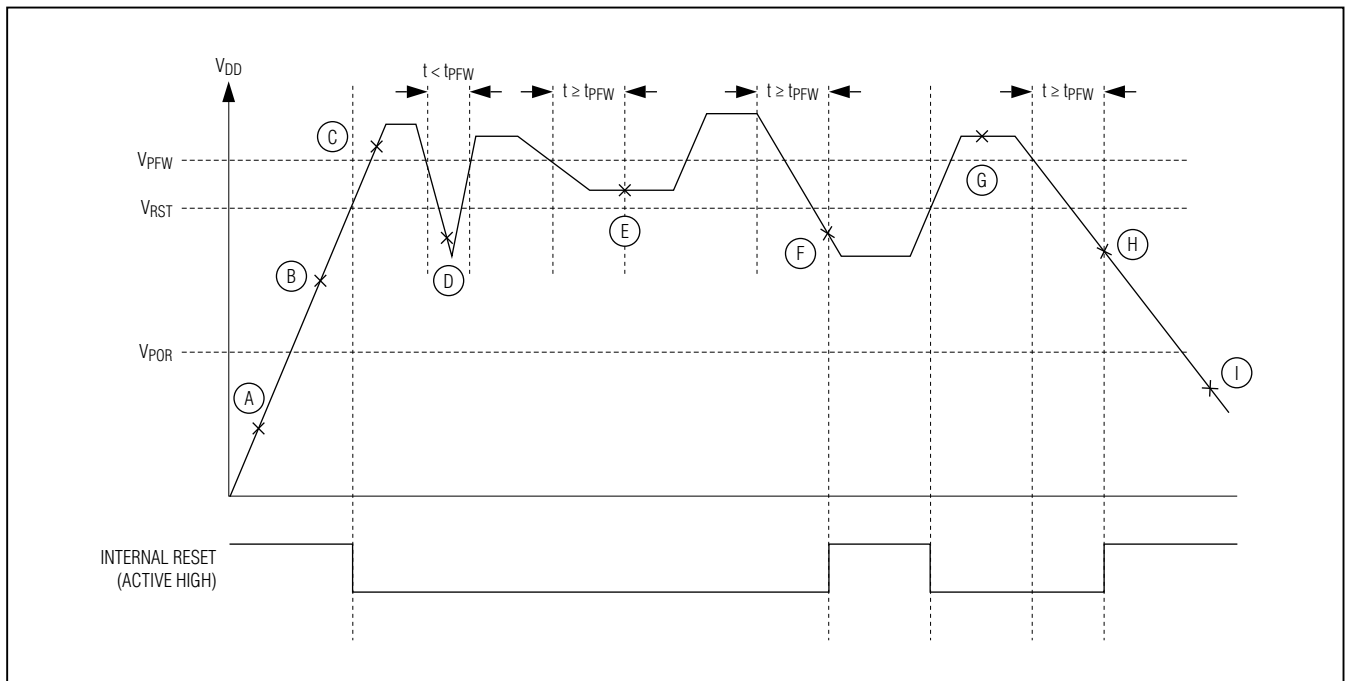

Figure 11. Power-Fail Detection During Normal Operation

**16-Bit Microcontroller with Infrared Module****Table 4. Power-Fail Detection States During Normal Operation**

STATE	POWER-FAIL	INTERNAL REGULATOR	CRYSTAL OSCILLATOR	SRAM RETENTION	COMMENTS
A	On	Off	Off	—	$V_{DD} < V_{POR}$ .
B	On	On	On	—	$V_{POR} < V_{DD} < V_{RST}$ . Crystal warmup time, $t_{XTAL\_RDY}$ . CPU held in reset.
C	On	On	On	—	$V_{DD} > V_{RST}$ . CPU normal operation.
D	On	On	On	—	Power drop too short. Power-fail not detected.
E	On	On	On	—	$V_{RST} < V_{DD} < V_{PFW}$ . PFI is set when $V_{RST} < V_{DD} < V_{PFW}$ and maintains this state for at least $t_{PFW}$ , at which time a power-fail interrupt is generated (if enabled). CPU continues normal operation.
F	On (Periodically)	Off	Off	Yes	$V_{POR} < V_{DD} < V_{RST}$ . Power-fail detected. CPU goes into reset. Power-fail monitor turns on periodically.
G	On	On	On	—	$V_{DD} > V_{RST}$ . Crystal warmup time, $t_{XTAL\_RDY}$ . CPU resumes normal operation from 8000h.
H	On (Periodically)	Off	Off	Yes	$V_{POR} < V_{DD} < V_{RST}$ . Power-fail detected. CPU goes into reset. Power-fail monitor turns on periodically.
I	Off	Off	Off	—	$V_{DD} < V_{POR}$ . Device held in reset. No operation allowed.

# MAXQ613

## 16-Bit Microcontroller with Infrared Module

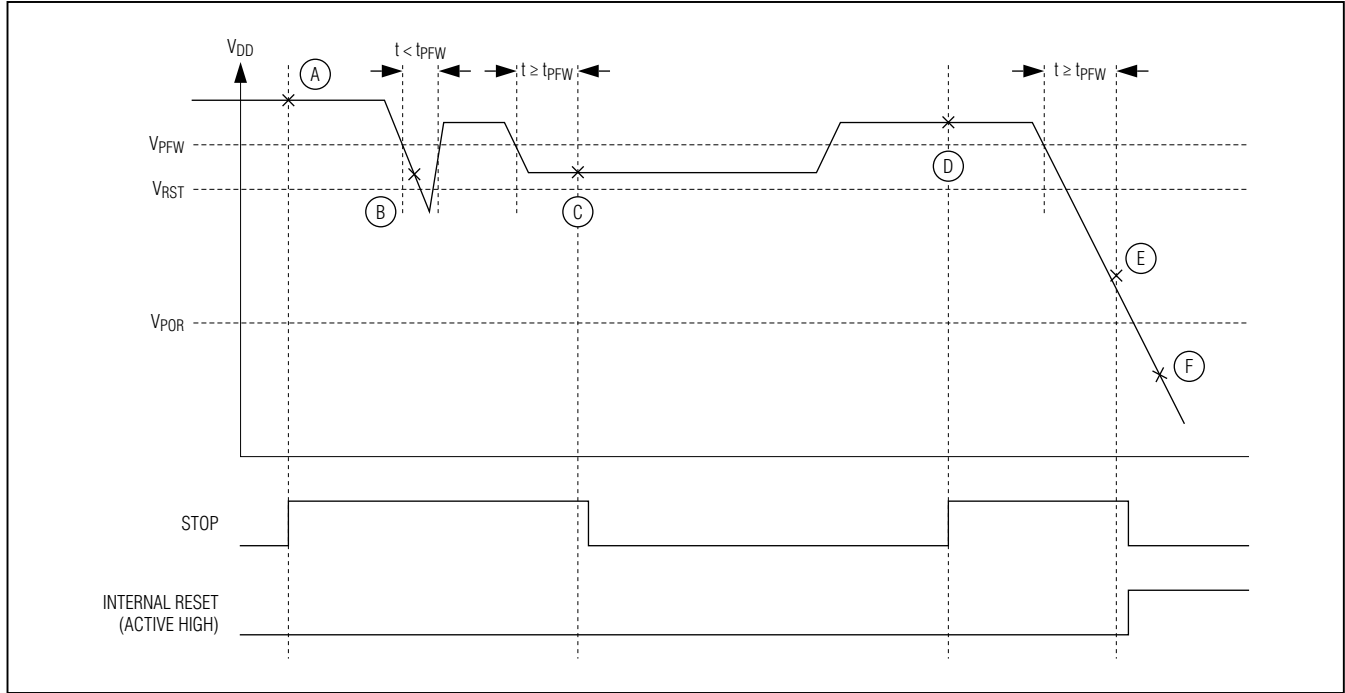

Figure 12. Stop Mode Power-Fail Detection States with Power-Fail Monitor Enabled

**Table 5. Stop Mode Power-Fail Detection States with Power-Fail Monitor Enabled**

STATE	POWER-FAIL	INTERNAL REGULATOR	CRYSTAL OSCILLATOR	SRAM RETENTION	COMMENTS
A	On	Off	Off	Yes	Application enters stop mode. VDD > VRST. CPU in stop mode.
B	On	Off	Off	Yes	Power drop too short. Power-fail not detected.
C	On	On	On	Yes	VRST < VDD < VPPFW. Power-fail warning detected. Turn on regulator and crystal. Crystal warmup time, tXTAL_RDY. Exit stop mode.
D	On	Off	Off	Yes	Application enters stop mode. VDD > VRST. CPU in stop mode.
E	On (Periodically)	Off	Off	Yes	VPOR < VDD < VRST. Power-fail detected. CPU goes into reset. Power-fail monitor turns on periodically.
F	Off	Off	Off	—	VDD < VPOR. Device held in reset. No operation allowed.

## 16-Bit Microcontroller with Infrared Module

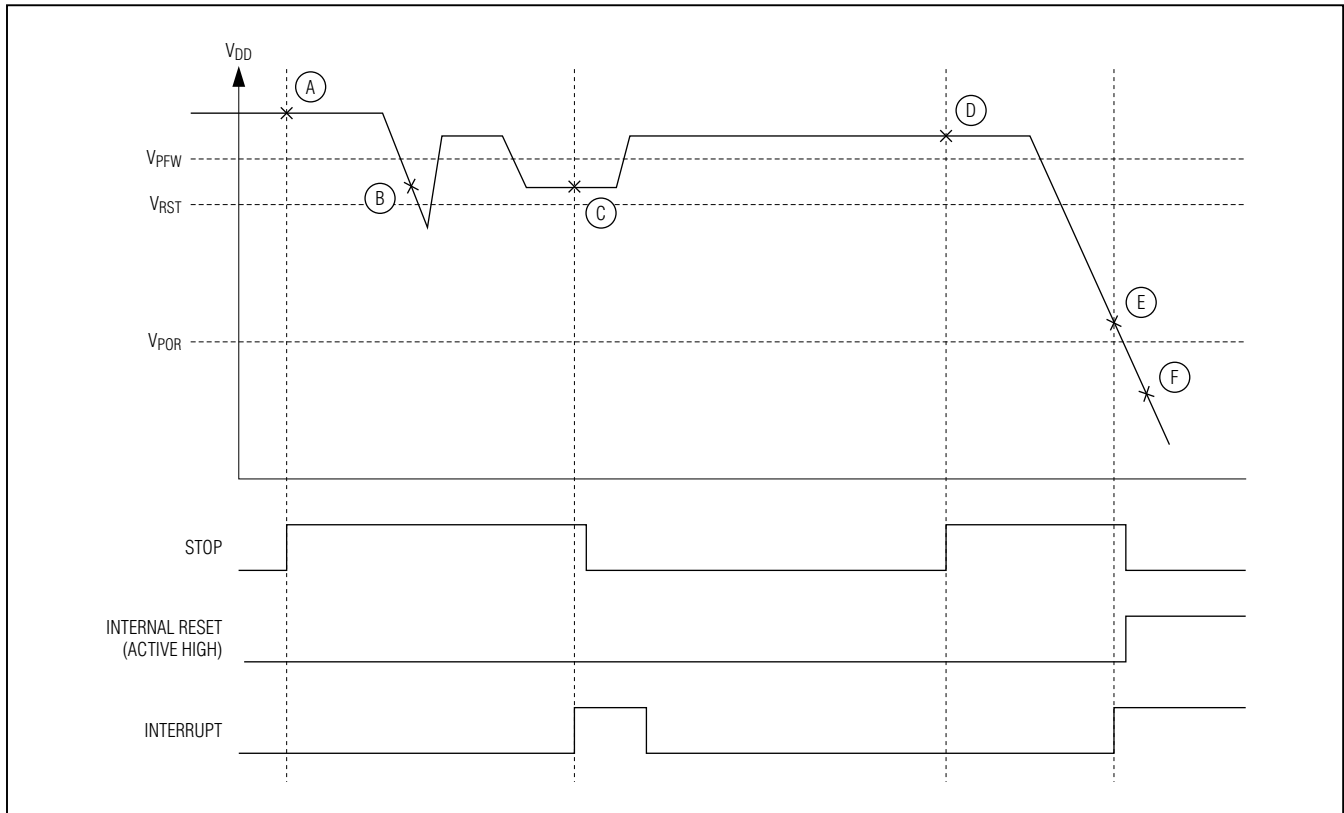

Figure 13. Stop Mode Power-Fail Detection with Power-Fail Monitor Disabled

**Table 6. Stop Mode Power-Fail Detection States with Power-Fail Monitor Disabled**

STATE	POWER-FAIL	INTERNAL REGULATOR	CRYSTAL OSCILLATOR	SRAM RETENTION	COMMENTS
A	Off	Off	Off	Yes	Application enters stop mode. $V_{DD} > V_{RST}$ . CPU in stop mode.
B	Off	Off	Off	Yes	$V_{DD} < V_{PFW}$ . Power-fail not detected because power-fail monitor is disabled.
C	On	On	On	Yes	$V_{RST} < V_{DD} < V_{PFW}$ . An interrupt occurs that causes the CPU to exit stop mode. Power-fail monitor is turned on, detects a power-fail warning, and sets the power-fail interrupt flag. Turn on regulator and crystal. Crystal warmup time, $t_{XTAL\_RDY}$ . On stop mode exit, CPU vectors to the higher priority of power-fail and the interrupt that causes stop mode exit.

# MAXQ613

## 16-Bit Microcontroller with Infrared Module

**Table 6. Stop Mode Power-Fail Detection States with Power-Fail Monitor Disabled (continued)**

STATE	POWER-FAIL	INTERNAL REGULATOR	CRYSTAL OSCILLATOR	SRAM RETENTION	COMMENTS
D	Off	Off	Off	Yes	Application enters stop mode. $V_{DD} > V_{RST}$ . CPU in stop mode.
E	On (Periodically)	Off	Off	Yes	$V_{POR} < V_{DD} < V_{RST}$ . An interrupt occurs that causes the CPU to exit stop mode. Power-fail monitor is turned on, detects a power-fail, and puts CPU in reset. Power-fail monitor is turned on periodically.
F	Off	Off	Off	—	$V_{DD} < V_{POR}$ . Device held in reset. No operation allowed.

### Applications Information

The low-power, high-performance RISC architecture of this device makes it an excellent fit for many portable or battery-powered applications. It is ideally suited for applications such as universal remote controls that require the cost-effective integration of IR transmit/receive capability.

#### Grounds and Bypassing

Careful PCB layout significantly minimizes system-level digital noise that could interact with the microcontroller or peripheral components. The use of multilayer boards is essential to allow the use of dedicated power planes. The area under any digital components should be a continuous ground plane if possible. Keep bypass capacitor leads short for best noise rejection and place the capacitors as close to the leads of the devices as possible.

CMOS design guidelines for any semiconductor require that no pin be taken above  $V_{DD}$  or below GND. Violation of this guideline can result in a hard failure (damage to the silicon inside the device) or a soft failure (unintentional modification of memory contents). Voltage spikes above or below the device's absolute maximum ratings can potentially cause a devastating IC latchup.

Microcontrollers commonly experience negative voltage spikes through either their power pins or general-

purpose I/O pins. Negative voltage spikes on power pins are especially problematic as they directly couple to the internal power buses. Devices such as keypads can conduct electrostatic discharges directly into the microcontroller and seriously damage the device. System designers must protect components against these transients that can corrupt system memory.

### Additional Documentation

Designers must have the following documents to fully use all the features of this device. This data sheet contains pin descriptions, feature overviews, and electrical specifications. Errata sheets contain deviations from published specifications. The user's guides offer detailed information about device features and operation. The following documents can be downloaded from [www.maximintegrated.com/microcontrollers](http://www.maximintegrated.com/microcontrollers).

- This MAXQ613 data sheet, which contains electrical/timing specifications, pin descriptions, and package information.
- The MAXQ613 revision-specific errata sheet ([www.maximintegrated.com/errata](http://www.maximintegrated.com/errata)).
- The *MAXQ610 User's Guide*, which contains detailed information on features and operation, including programming.

## 16-Bit Microcontroller with Infrared Module

### **Deviations from the MAXQ610 User's Guide for the MAXQ613**

The *MAXQ610 User's Guide* contains all the information that is needed to develop application code for the MAXQ613 microcontroller. However, even though the MAXQ610 and the MAXQ613 are largely code-compatible, there are certain differences between the two devices that must be kept in mind when referring to the *MAXQ610 User's Guide*.

The following registers on the MAXQ610 (which are described in the *MAXQ610 User's Guide*) do not exist on the MAXQ613, and all references to them should be disregarded:

- Port 3 Output Register (PO3)
- Port 3 Direction Register (PD3)
- Port 3 Input Register (PI3)
- Port 4 Output Register (PO4)
- Port 4 Direction Register (PD4)
- Port 4 Input Register (PI4)

### **Development and Technical Support**

Maxim and third-party suppliers provide a variety of highly versatile, affordably priced development tools for this microcontroller, including the following:

- Compilers
- In-circuit emulators
- Integrated Development Environments (IDEs)
- Serial-to-JTAG and USB-to-JTAG interface boards for programming and debugging (for microcontrollers with rewritable memory)

A partial list of development tool vendors can be found at [www.maximintegrated.com/MAXQ\\_tools](http://www.maximintegrated.com/MAXQ_tools).

For technical support, go to <https://support.maximintegrated.com/micro>.

### **Package Information**

For the latest package outline information and land patterns (footprints), go to [www.maximintegrated.com/packages](http://www.maximintegrated.com/packages). Note that a "+", "#", or "-" in the package code indicates RoHS status only. Package drawings may show a different suffix character, but the drawing pertains to the package regardless of RoHS status.

PACKAGE TYPE	PACKAGE CODE	OUTLINE NO.	LAND PATTERN NO.
32 TQFN-EP	T3255+3	<a href="#">21-0140</a>	<a href="#">90-0001</a>
44 TQFN-EP	T4477+2	<a href="#">21-0144</a>	<a href="#">90-0127</a>

# MAXQ613

## 16-Bit Microcontroller with Infrared Module

### Revision History

REVISION NUMBER	REVISION DATE	DESCRIPTION	PAGES CHANGED
0	7/10	Initial release	—
1	7/10	Corrected bare die numbers in the <i>Pin Description</i> table for V <sub>DD</sub> , GND, $\overline{\text{RESET}}$ , IRTX, IRRX, P2.5/TDI, P2.6/TMS, and P2.7/TDO	9, 10, 11
2	8/10	Corrected the active mode typ value from 2.0mA to 3.25mA in the <i>Features</i>	1
3	1/11	Removed the LQFP and TQFP packages	1, 4, 8, 9, 10, 27
4	7/12	Removed the ESR reference from the REGOUT description in the <i>Pin Description</i> table; changed the MAXQ core reference to MAXQ20S core in the <i>Microprocessor</i> section; updated the IRDIV bit range from [1:0] to [2:0] in the <i>Carrier Generation Module</i> section	8, 11, 14



Maxim Integrated cannot assume responsibility for use of any circuitry other than circuitry entirely embodied in a Maxim Integrated product. No circuit patent licenses are implied. Maxim Integrated reserves the right to change the circuitry and specifications without notice at any time. The parametric values (min and max limits) shown in the Electrical Characteristics table are guaranteed. Other parametric values quoted in this data sheet are provided for guidance.

## Looking for pricing, stock, or lifecycle information?

Click below to explore more details on WIN SOURCE:

 [View MAXQ613J-UEI+ on WIN SOURCE](#)

 [Maxim Integrated](#) Information

## Optimize Your Supply Chain with WIN SOURCE Solutions

-  Global Sourcing Solution
-  Obsolete Management
-  Cost Control Management
-  Shortage Management
-  Alternative Solution
-  Excess Inventory Management