



**THE DATASHEET OF  
MAX9452EHJ**





# High-Precision Clock Generators with Integrated VCXO

## General Description

The MAX9450/MAX9451/MAX9452 clock generators provide high-precision clocks for timing in SONET/SDH systems or Gigabit Ethernet systems. The MAX9450/MAX9451/MAX9452 can also provide clocks for the high-speed and high-resolution ADCs and DACs in 3G base stations. Additionally, the devices can also be used as a jitter attenuator for generating high-precision CLK signals.

The MAX9450/MAX9451/MAX9452 feature an integrated VCXO. This configuration eliminates the use of an external VCXO and provides a cost-effective solution for generating high-precision clocks. The MAX9450/MAX9451/MAX9452 feature two differential inputs and clock outputs. The inputs accept LVPECL, LVDS, differential signals, and LVCMOS. The input reference clocks range from 8kHz to 500MHz.

The MAX9450/MAX9451/MAX9452 offer LVPECL, HSTL, and LVDS outputs, respectively. The output range is up to 160MHz, depending on the selection of crystal. The input and output frequency selection is implemented through the I<sup>2</sup>C or SPI™ interface. The MAX9450/MAX9451/MAX9452 feature clock output jitter less than 0.8ps RMS (in a 12kHz to 20MHz band) and phase-noise attenuation greater than -130dBc/Hz at 100kHz. The phase-locked loop (PLL) filter can be set externally, and the filter bandwidth can vary from 1Hz to 20kHz.

The MAX9450/MAX9451/MAX9452 feature an input clock monitor with a hitless switch. When a failure is detected at the selected reference clock, the device can switch to the other reference clock. The reaction to the recovery of the failed reference clock can be revertive or nonrevertive. If both reference clocks fail, the PLL retains its nominal frequency within a range of ±20ppm at +25°C.

The MAX9450/MAX9451/MAX9452 operate from 2.4V to 3.6V supply and are available in 32-pin TQFP packages with exposed pads.

## Applications

- SONET/SDH Systems
- 10 Gigabit Network Routers and Switches
- 3G Cellular Phone Base Stations
- General Jitter Attenuation

SPI is a trademark of Motorola, Inc.

## Features

- ◆ Integrated VCXO Provides a Cost-Effective Solution for High-Precision Clocks
- ◆ 8kHz to 500MHz Input Frequency Range
- ◆ 15MHz to 160MHz Output Frequency Range
- ◆ I<sup>2</sup>C or SPI Programming for the Input and Output Frequency Selection
- ◆ PLL Lock Range > ±60ppm
- ◆ Two Differential Outputs with Three Types of Signaling: LVPECL, LVDS, or HSTL
- ◆ Input Clock Monitor with Hitless Switch
- ◆ Internal Holdover Function within ±20ppm of the Nominal Frequency
- ◆ Low Output CLK Jitter: < 0.8ps RMS in the 12kHz to 20MHz Band
- ◆ Low Phase Noise > -130dBc at 100kHz, > -140dBc at 1MHz

## Ordering Information

PART	PIN-PACKAGE	OUTPUT	PKG CODE
MAX9450EHJ	32 TQFP-EP*	LVPECL	H32E-6
MAX9451EHJ	32 TQFP-EP*	HSTL	H32E-6
MAX9452EHJ	32 TQFP-EP*	LVDS	H32E-6

**Note:** All devices are specified over the -40°C to +85°C temperature range.

For lead-free packages, contact factory.

\*EP = Exposed paddle.

## Pin Configuration

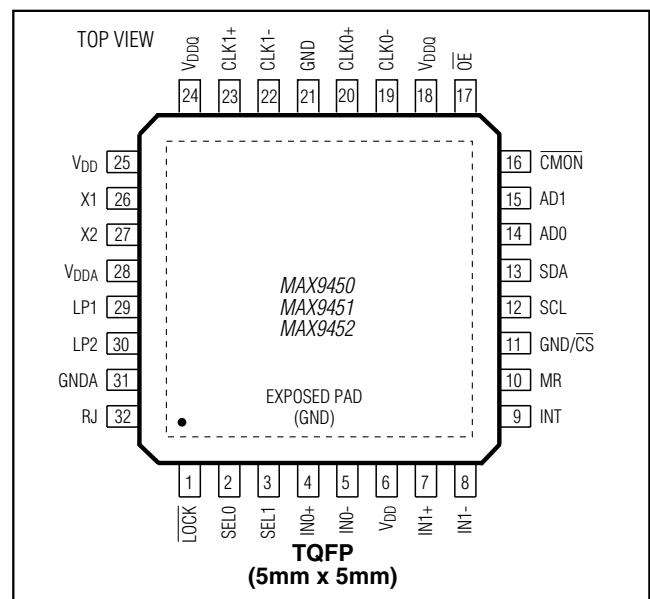

MAX9450/MAX9451/MAX9452

# High-Precision Clock Generators with Integrated VCXO

## ABSOLUTE MAXIMUM RATINGS

V<sub>DD</sub> to GND .....-0.3V to +4.0V  
 V<sub>D<sub>DDA</sub></sub> to G<sub>NDA</sub> .....-0.3V to +4.0V  
 All Other Pins to GND .....-0.3V to V<sub>DD</sub> + 0.3V  
 Short-Circuit Duration (all pins).....Continuous  
 Continuous Power Dissipation (T<sub>A</sub> = +85°C)  
 32-Pin TQFP (derate 27.8mW/°C above +70°C).....2222mW

Storage Temperature Range .....-65°C to +165°C  
 Maximum Junction Temperature .....+150°C  
 Operating Temperature Range .....-40°C to +85°C  
 Lead Temperature (soldering, 10s) .....+300°C  
 ESD Protection  
 Human Body Model (R<sub>D</sub> = 1.5kΩ, C<sub>S</sub> = 100pF) .....±2kV

Stresses beyond those listed under "Absolute Maximum Ratings" may cause permanent damage to the device. These are stress ratings only, and functional operation of the device at these or any other conditions beyond those indicated in the operational sections of the specifications is not implied. Exposure to absolute maximum rating conditions for extended periods may affect device reliability.

## DC ELECTRICAL CHARACTERISTICS

(V<sub>D<sub>DDA</sub></sub> = V<sub>DD</sub> = V<sub>DDQ</sub> = 2.4V to 3.6V, and V<sub>DDQ</sub> = 1.4V to 1.6V for MAX9451, T<sub>A</sub> = -40°C to +85°C. Typical values at V<sub>D<sub>DDA</sub></sub> = V<sub>DD</sub> = V<sub>DDQ</sub> = 3.3V, and V<sub>DDQ</sub> = 1.5V for MAX9451, T<sub>A</sub> = +25°C, unless otherwise noted.)

PARAMETER	SYMBOL	CONDITIONS	MIN	TYP	MAX	UNITS
<b>LVC MOS INPUT (SEL_, CMON, OE, MR)</b>						
Input High Level	V <sub>IH1</sub>		2.0		V <sub>DD</sub>	V
Input Low Level	V <sub>IL1</sub>		0		0.8	V
Input Current	I <sub>IN1</sub>	V <sub>IN</sub> = 0V to V <sub>DD</sub>	-50		+50	μA
<b>LVC MOS OUTPUT (INT, LOCK)</b>						
Output High Level	V <sub>OH1</sub>	I <sub>OH1</sub> = -4mA	V <sub>DD</sub> - 0.4			V
Output Low Level	V <sub>OL1</sub>	I <sub>OL1</sub> = 4mA			0.4	V
<b>THREE-LEVEL INPUT (AD0, AD1)</b>						
Input High Level	V <sub>IH2</sub>		1.8			V
Input Low Level	V <sub>IL2</sub>				0.8	V
Input Open Level	V <sub>IO2</sub>	Measured at the opened inputs	1.05		1.35	V
Input Current	I <sub>IL2</sub> , I <sub>IH2</sub>	V <sub>IL2</sub> = 0V or V <sub>IH2</sub> = V <sub>DD</sub>	-15		+15	μA
<b>DIFFERENTIAL INPUTS (IN0, IN1)</b>						
Differential Input High Threshold	V <sub>IDH</sub>	V <sub>ID</sub> = V <sub>IN+</sub> - V <sub>IN-</sub>			50	mV
Differential Input Low Threshold	V <sub>IDL</sub>	V <sub>ID</sub> = V <sub>IN+</sub> - V <sub>IN-</sub>	-50			mV
Common-Mode Input-Voltage Range	V <sub>COM</sub>	V <sub>ID</sub> = V <sub>IN+</sub> - V <sub>IN-</sub>	V <sub>ID</sub> / 2		2.4 -  V <sub>ID</sub> / 2	V
Input Current	I <sub>IN+</sub> , I <sub>IN-</sub>		-1		+1	μA
<b>MAX9450 OUTPUTS (CLK0, CLK1) (LVPECL)</b>						
Output High Voltage	V <sub>OH2</sub>	50Ω load connected to V <sub>DDQ</sub> - 2.0V	V <sub>DDQ</sub> - 1.42		V <sub>DDQ</sub> - 1.00	V
Output Low Voltage	V <sub>OL2</sub>	50Ω load connected to V <sub>DDQ</sub> - 2.0V	V <sub>DDQ</sub> - 2.15		V <sub>DDQ</sub> - 1.70	V
<b>MAX9451 OUTPUTS (CLK0, CLK1) (differential HSTL)</b>						
Output High-Level Voltage	V <sub>OH3</sub>	With 50Ω load resistor to GND, Figure 1	V <sub>DDQ</sub> - 0.4V		V <sub>DDQ</sub>	V
Output Low-Level Voltage	V <sub>OL3</sub>	With 50Ω to GND and 16mA sink current			0.4	V
<b>MAX9452 OUTPUTS (CLK0, CLK1) (LVDS)</b>						
Differential Output Voltage	V <sub>OD</sub>	With a total 100Ω load, Figure 1	300	370	450	mV
Change in V <sub>OD</sub> Between Complementary Output States	ΔV <sub>OD</sub>			10	35	mV

# High-Precision Clock Generators with Integrated VCXO

MAX9450/MAX9451/MAX9452

## DC ELECTRICAL CHARACTERISTICS (continued)

( $V_{DDA} = V_{DD} = V_{DDQ} = 2.4V$  to  $3.6V$ , and  $V_{DDQ} = 1.4V$  to  $1.6V$  for MAX9451,  $T_A = -40^{\circ}C$  to  $+85^{\circ}C$ . Typical values at  $V_{DDA} = V_{DD} = V_{DDQ} = 3.3V$ , and  $V_{DDQ} = 1.5V$  for MAX9451,  $T_A = +25^{\circ}C$ , unless otherwise noted.)

PARAMETER	SYMBOL	CONDITIONS	MIN	TYP	MAX	UNITS
Output Offset Voltage	$V_{OS}$		1.05	1.2	1.35	V
Change in $V_{OS}$ Between Complementary Output States	$\Delta V_{OS}$			10	35	mV
Output Short-Circuit Current	$I_{OS}$	Two output pins connected to GND		-7.5	-15	mA
<b>SERIAL INTERFACE INPUT, OUTPUT (SCL, SDA, CS)</b>						
Input High Level	$V_{IH}$		0.7 $\times V_{DD}$			V
Input Low Level	$V_{IL}$				0.3 $\times V_{DD}$	V
Input Leakage Current	$I_{IL}$		-1		+1	$\mu A$
Output Low Level	$V_{OL}$	3mA sink current			0.4	V
Input Capacitance	$C_I$			10		pF
<b>POWER CONSUMPTION</b>						
$V_{DD}$ and $V_{DDA}$ Supply Current	$I_{CC1}$	Output clock frequency = 155MHz	MAX9450	55	85	mA
			MAX9451	70	94	
			MAX9452	65	88	
$V_{DDQ}$ Supply Current	$I_{CC2}$	Output clock frequency = 155MHz (MAX9450)	MAX9450	55	80	mA
			MAX9451	65	80	
			MAX9452	14	25	

## AC ELECTRICAL CHARACTERISTICS

( $V_{DDA} = V_{DD} = V_{DDQ} = 2.4V$  to  $3.6V$ , and  $V_{DDQ} = 1.4V$  to  $1.6V$  for MAX9451,  $T_A = -40^{\circ}C$  to  $+85^{\circ}C$ .  $|V_{ID}| = 200mV$ ,  $V_{COM} = |V_{ID}| / 2I$  to  $2.4 - |V_{ID}| / 2I$ . Typical values at  $V_{DDA} = V_{DD} = V_{DDQ} = 3.3V$  and  $V_{DDQ} = 1.5V$  for MAX9451,  $T_A = +25^{\circ}C$ .  $C_L = 10pF$ , clock output = 155.5MHz and clock input = 19.44MHz, unless otherwise noted.) (Note 1)

PARAMETER	SYMBOL	CONDITIONS	MIN	TYP	MAX	UNITS
<b>CLK OUTPUTS (CLK0, CLK1)</b>						
Reference Input Frequency	$f_{IN}$	Measured at IN0 or IN1	0.008		500	MHz
Output Frequency	$f_{OUT}$	Measured at CLK0 or CLK1	15		160	MHz
VCXO Pulling Range		$C_L = 8pF$ (Note 2)			$\pm 60$	ppm
Output-to-Output Skew	$t_{SKO}$	Skew between CLK0 and CLK1 (MAX9450 and MAX9452)		50	90	ps
		Skew between CLK0 and CLK1 (MAX9451)		55	106	
Rise Time	$t_R$	20% to 80% of output swing		0.4	0.590	ns
Fall Time	$t_F$	80% to 20% of output swing		0.4	0.590	ns
Duty Cycle			43		56	%
Period Jitter (RMS)	$T_J$	Measured at the band 12kHz to 20MHz		0.8		ps
Phase Noise		1kHz offset		-70		dBc
		10kHz offset		-110		
		100kHz offset		-130		
		1MHz offset		-140		

# High-Precision Clock Generators with Integrated VCXO

## SERIAL I<sup>2</sup>C-COMPATIBLE INTERFACE TIMING CHARACTERISTICS

(V<sub>DD</sub> = 2.4V to 3.6V, T<sub>A</sub> = -40°C to +85°C. See Figure 4 for the timing parameters definition.)

PARAMETER	SYMBOL	CONDITIONS	MIN	TYP	MAX	UNITS
Serial Clock	f <sub>SCL</sub>				400	kHz
Bus Free Time Between STOP and START Conditions	t <sub>BUF</sub>		1.3			μs
Repeated Hold Time START Condition	t <sub>HD,STA</sub>		0.6			μs
Repeated START Condition Setup Time	t <sub>SU,STA</sub>		0.6			μs
STOP Condition Setup Time	t <sub>SU,STO</sub>		0.6			μs
Data Hold Time	t <sub>HD,DAT</sub>	(Note 3)	100			ns
Data Setup Time	t <sub>SU,DAT</sub>		100			ns
SCL Clock-Low Period	t <sub>LOW</sub>		1.3			μs
SCL Clock-High Period	t <sub>HIGH</sub>		0.7			μs
Maximum Receive SCL/SDA Rise Time	t <sub>R</sub>			300		ns
Minimum Receive SCL/SDA Rise Time	t <sub>R</sub>	(Note 4)		20 + 0.1 × C <sub>b</sub>		ns
Maximum Receive SCL/SDA Fall Time	t <sub>F</sub>			300		ns
Minimum Receive SCL/SDA Fall Time	t <sub>F</sub>	(Note 4)		20 + 0.1 × C <sub>b</sub>		ns
Fall Time of SDA, Transmitting	t <sub>F,TX</sub>	(Note 4)		20 + 0.1C <sub>b</sub>	250	ns
Pulse Width of Suppressed Spike	t <sub>SP</sub>	(Note 5)	0		50	ns
Capacitive Load for Each Bus Line	C <sub>B</sub>	(Note 4)			400	pF

## SERIAL SPI INTERFACE TIMING CHARACTERISTICS

(V<sub>DD</sub> = 2.4V to 3.6V, T<sub>A</sub> = -40°C to +85°C. See Figure 7 for the timing parameters definition.)

PARAMETER	SYMBOL	CONDITIONS	MIN	TYP	MAX	UNITS
Serial-Clock Frequency	f <sub>SCL</sub>				2	MHz
$\overline{\text{CS}}$ Fall to CLK Rise Setup Time	t <sub>CSS</sub>		12.5			ns
DIN Setup Time	t <sub>DS</sub>		12.5			ns
DIN Hold Time	t <sub>DH</sub>		0			ns
CLK High to $\overline{\text{CS}}$ High	t <sub>CSH</sub>		0			ns
$\overline{\text{CS}}$ Pulse-High Time	t <sub>CSW</sub>		20			ns

**Note 1:** All timing AC electrical characteristics and timing specifications are guaranteed by design and not production tested.

**Note 2:** The VCXO tracks the input clock frequency by ±60ppm.

**Note 3:** A master device must provide a hold time of at least 300ns for the SDA signal to bridge the undefined regions of SCL's falling edge.

**Note 4:** C<sub>B</sub> = total capacitance of one bus line in pF. Tested with C<sub>B</sub> = 400pF.

**Note 5:** Input filters on SDA and SCL suppress noise spikes less than 50ns.

# High-Precision Clock Generators with Integrated VCXO

## Typical Operating Characteristics

( $V_{DD} = V_{DDA} = V_{DDQ} = 3.3V$ ,  $T_A = +25^\circ C$ , unless otherwise noted.)

**$V_{DD}$  AND  $V_{DDA}$  SUPPLY CURRENT vs. VOLTAGE (MAX9450)**

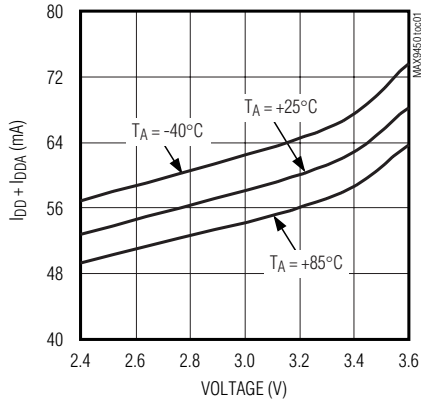

**$V_{DDQ}$  SUPPLY CURRENT vs. VOLTAGE (MAX9450)**

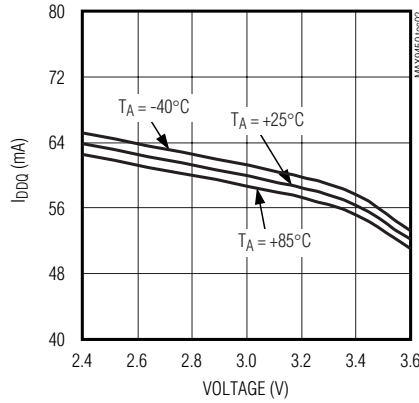

**OUTPUT RMS JITTER vs. TEMPERATURE**

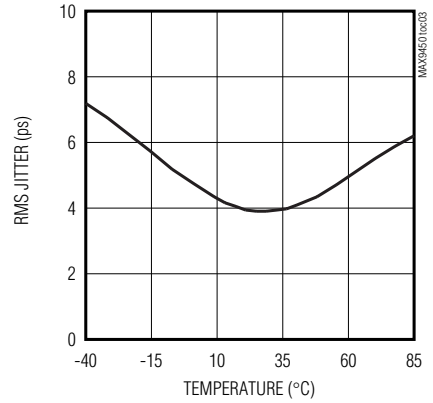

**OUTPUT FREQUENCY CHANGE vs. TEMPERATURE**

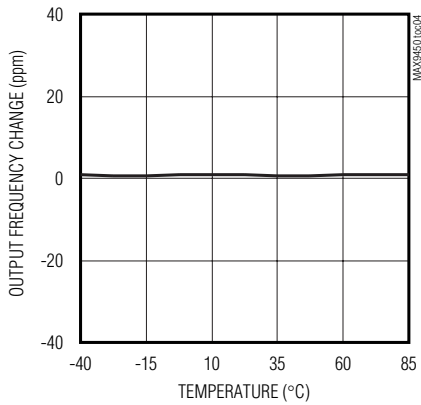

**PHASE NOISE vs. FREQUENCY**

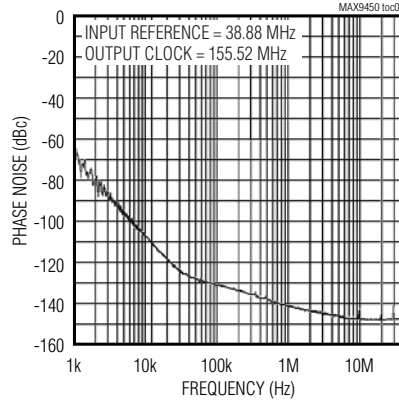

**OUTPUT CLOCK SYNCHRONIZED TO INPUT REFERENCE**

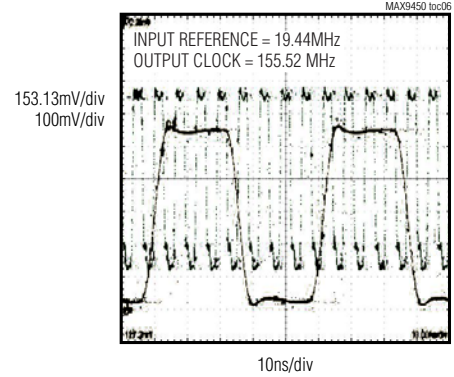

MAX9450/MAX9451/MAX9452

# High-Precision Clock Generators with Integrated VCXO

## Pin Description

PIN	NAME	FUNCTION
1	$\overline{\text{LOCK}}$	Lock Indicator. $\overline{\text{LOCK}}$ goes low when the PLL locks. $\overline{\text{LOCK}}$ is high when the PLL is not locked.
2, 3	SEL0, SEL1	IN0_ and IN1_ Select Inputs. Drive SEL0 high to activate IN0; drive SEL1 high to activate IN1. Driving SEL0 and SEL1 low disables the corresponding input. A 165k $\Omega$ pullup resistor pulls SEL0 and SEL1 up to V <sub>DD</sub> .
4, 5	IN0+, IN0-	Differential Reference Input Pair. IN0+ and IN0- accept LVPECL, LVDS, and LVCMOS signals.
6, 25	V <sub>DD</sub>	Digital Power Supply. Connect a 2.4V to 3.6V power supply to V <sub>DD</sub> . Bypass V <sub>DD</sub> to GND with a 0.1 $\mu$ F capacitor.
7, 8	IN1+, IN1-	Differential Reference Input Pair. IN1+ and IN1- accept LVPECL, LVDS, and LVCMOS signals.
9	INT	Reference Input Condition Indicator. A high indicates a failed reference.
10	MR	Master Reset. Drive MR high to reset all I <sup>2</sup> C registers to their default state and INT to zero.
11	GND/ $\overline{\text{CS}}$	Ground and Chip-Select Input. Connect to GND in I <sup>2</sup> C mode. This is the chip-select input in SPI mode.
12	SCL	Clock Input. SCL is the clock input in I <sup>2</sup> C bus mode and SPI bus mode.
13	SDA	Data Input. SDA is the data input in I <sup>2</sup> C bus mode and SPI bus mode.
14, 15	AD0, AD1	I <sup>2</sup> C Address Selection. Drive AD0 and AD1 high to convert the serial interface from I <sup>2</sup> C to SPI. GND/ $\overline{\text{CS}}$ becomes $\overline{\text{CS}}$ . See Table 3 for the unique addresses list.
16	$\overline{\text{CMON}}$	Clock Monitor. Drive $\overline{\text{CMON}}$ low to enable the clock monitor. Drive $\overline{\text{CMON}}$ high to disable the clock monitor.
17	$\overline{\text{OE}}$	Output Enable Input. Drive $\overline{\text{OE}}$ low to enable the clock outputs. Driving $\overline{\text{OE}}$ high disables the clock outputs, and the outputs go high impedance. An internal 165k $\Omega$ pullup resistor pulls $\overline{\text{OE}}$ up to V <sub>DD</sub> .
18, 24	V <sub>DDQ</sub>	Clock-Output Power Supply. Connect a 2.4V to 3.6V power supply to V <sub>DDQ</sub> for the MAX9450 and MAX9452. Connect a 1.5V power supply to V <sub>DDQ</sub> for the MAX9451. Connect a 0.1 $\mu$ F bypass capacitor from V <sub>DDQ</sub> to GND.
19, 20	CLK0-, CLK0+	Differential Clock Output 0. The MAX9450 features LVPECL outputs. The MAX9451 features HSTL outputs and the MAX9452 features LVDS outputs.
21	GND	Digital GND
22, 23	CLK1-, CLK1+	Differential Clock Output 1. The MAX9450 features LVPECL outputs. The MAX9451 features HSTL outputs, and the MAX9452 features LVDS outputs.
26, 27	X1, X2	Reference Crystal Input. Connect the reference crystal from X1 to X2.
28	V <sub>DDA</sub>	Analog Power Supply. Connect a 2.4V to 3.6V power supply to V <sub>DDA</sub> . Bypass V <sub>DDA</sub> to GNDA with a 0.1 $\mu$ F capacitor.
29, 30	LP1, LP2	External Loop Filter. Connect an RC circuit between LP1 and LP2. See the <i>External Loop Filter</i> section.
31	GNDA	Analog Ground
32	RJ	Charge-Pump Set Current. Connect an external resistor to GND to set the charge-pump current. See Table 11.
EP	EP	Exposed Paddle. Connect to ground.

# High-Precision Clock Generators with Integrated VCXO

## Functional Diagram

MAX9450/MAX9451/MAX9452

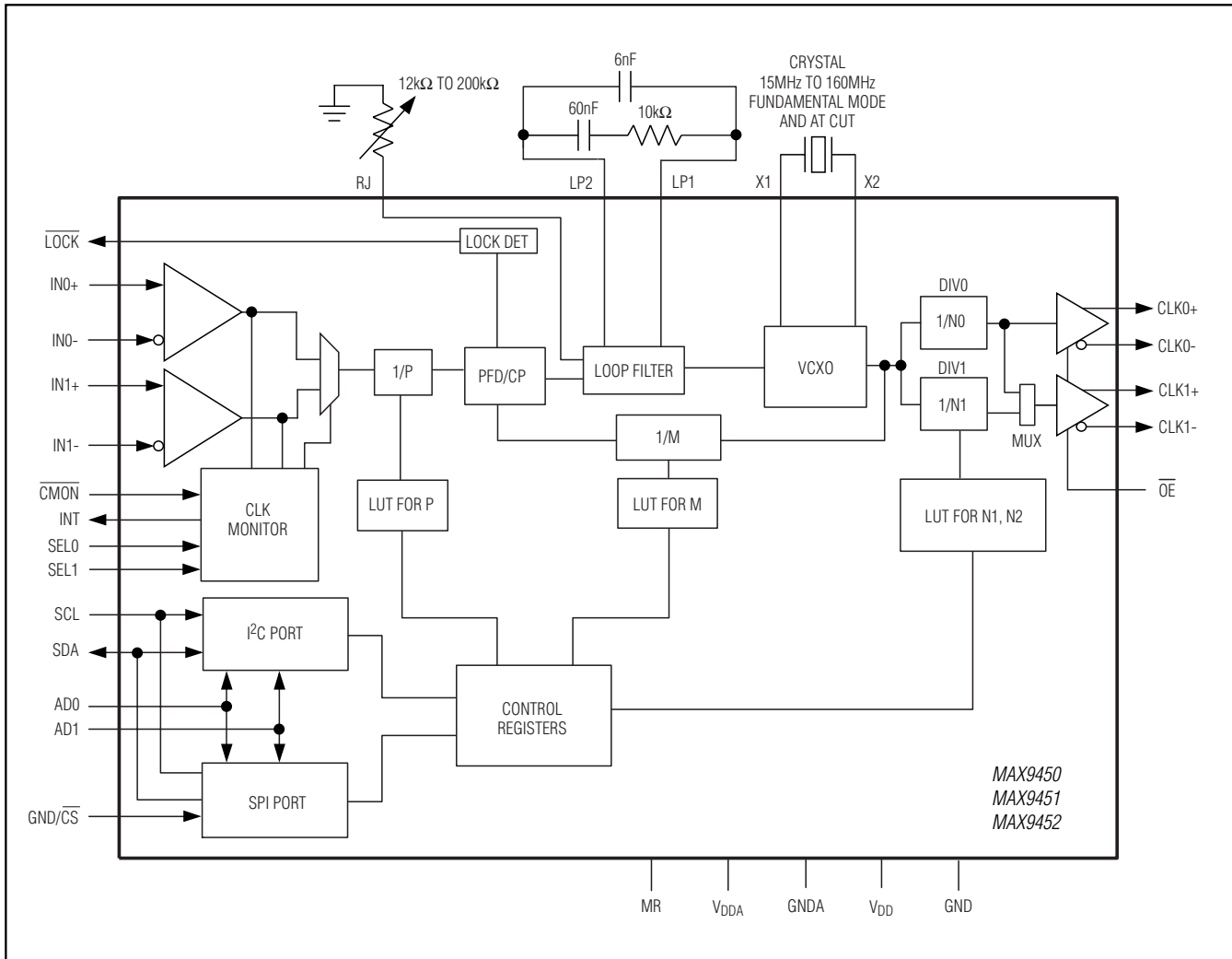

### Detailed Description

The MAX9450/MAX9451/MAX9452 clock generators provide high-precision clocks for timing in SONET/SDH systems or Gigabit Ethernet systems. The MAX9450/MAX9451/MAX9452 can also provide clocks for the high-speed and high-resolution ADCs and DACs in 3G base stations. Additionally, the MAX9450/MAX9451/MAX9452 can be used as a jitter attenuator for generating high-precision clock signals.

The MAX9450/MAX9451/MAX9452 feature two differential inputs and two differential clock outputs. The inputs accept LVPECL, LVDS, and LVCMOS signals. The

input reference clock ranges from 8kHz to 500MHz and the output clock ranges from 15MHz to 160MHz. The internal clock monitor observes the condition of the input reference clocks and provides a hitless switch when an input failure is detected. The MAX9450/MAX9451/MAX9452 also provide holdover in case no input clock is supplied.

### Control and Status Registers

The MAX9450/MAX9451/MAX9452 contain eight 8-bit control registers named CR0 to CR7. The registers are accessible through the I<sup>2</sup>C/SPI interface. CR0 is for the frequency-dividing factor, P. CR1 and CR2 hold the values of the divider, M. CR3 and CR4 are for dividers

# High-Precision Clock Generators with Integrated VCXO

N1 and N2, respectively. CR5 and CR6 are the control function registers for output enabling, reference clock selection, and activation of the clock monitor and the holdover function. CR7 contains the status of clock monitor, holdover, and PLL locking. The addresses of the eight registers are shown in Table 4. Tables 5 through 10 show the register maps.

### Output Buffers

Three different output formats (LVPECL, HSTL, and LVDS) are available. Each output contains its own frequency divider. All the output clocks align to their coincident rising edges. After changing the dividing ratio, the output clocks complete the current cycle and stay logic-low until the rising edges of the newly divided clock. When CR5[7] is high, the MAX9450/MAX9451/MAX9452 set all the outputs to logic-low. Setting the bits CR5[6] and CR5[5] properly enables and disables the outputs individually; see Table 8. A disabled output is always in high impedance. At the receiver end, the two cables or PCB traces can be terminated as shown in Figure 1.

The VCXO output is divided down before driving the output buffers. Program the dividing factor through the serial interface. The MAX9450/MAX9451/MAX9452 feature two output dividers DIV0 and DIV1 (see the *Functional Diagram*). DIV0 drives OUT0 and either DIV0 or DIV1 can drive OUT1. CR6[2] sets which divider output drives OUT1. This function allows for programming OUT1 and OUT0 to different frequencies.

### Reference Clock Inputs

The MAX9450/MAX9451/MAX9452 feature two “anything” differential clock inputs. “Anything” means that the inputs take any differential signals, such as CML, LVDS, LVPECL, or HSTL. The inputs can also take a single-ended input. For example, with LVCMOS reference inputs, connect the inputs to the positive pins INn+ and connect the negative pins INn- to a reference voltage of  $V_{DD} - 1.32V$ . See Figure 2.

Setting CR5[4] and CR6[3] selects the input reference. Failure detection and revert function apply only to IN0 and IN1. Also, SEL0 and SEL1 or CR5[3:2] can disable the corresponding inputs. See Table 2.

### Frequency Selection and Programming

The output frequency at  $CLK_n$ , ( $n = 0, 1$ ) is determined by the reference clock and the dividing factors  $M$ ,  $N_i$  ( $i = 0, 1$ ), and  $P$ , shown in the following equation:

$$f_{CLK_n} = f_{REF} \times \frac{M}{N_i \times P}$$

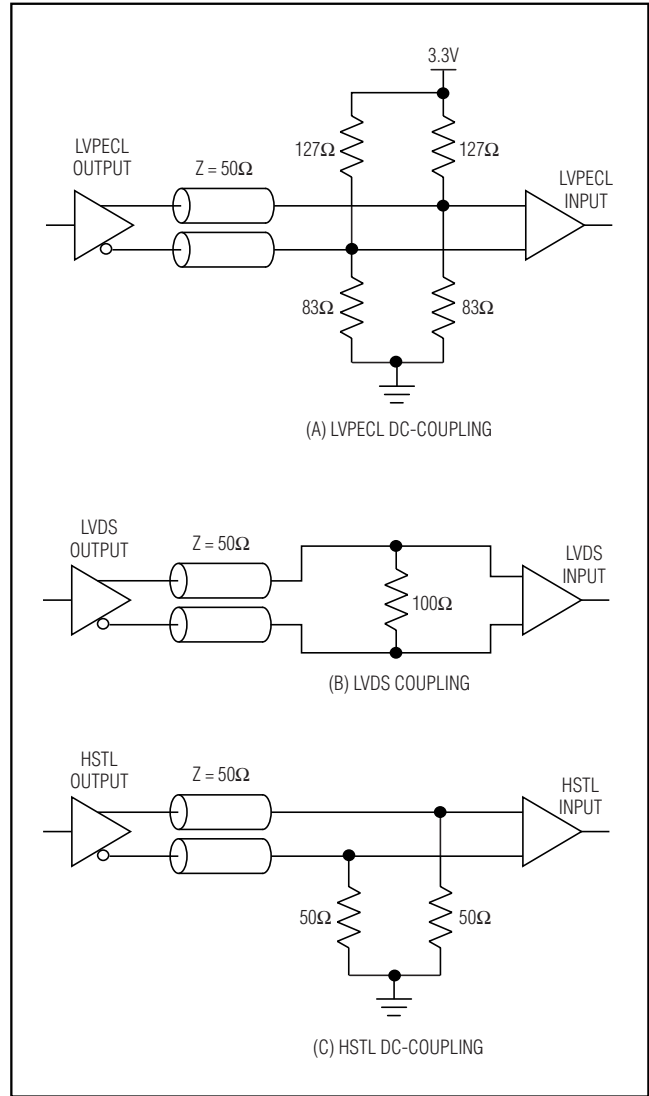

Figure 1. DC LVPECL, LVDS, and HSTL Termination

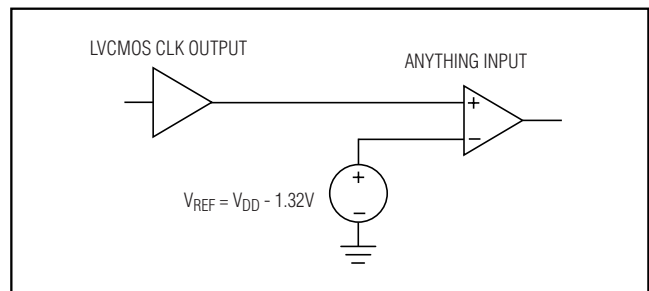

Figure 2. Connecting LVCMOS Output to LVPECL Input

# High-Precision Clock Generators with Integrated VCXO

MAX9450/MAX9451/MAX9452

where  $f_{CLKn}$  is the frequency at the CLK<sub>n</sub> output,  $f_{REF}$  is the frequency of the reference clock, M (1 to 32,768) is the dividing factor in the feedback loop, Ni (1, 2, 3, 4, 5, 6, 8, 16) are the dividing factors of the outputs, and P (1 to 256) is the dividing factor to the input reference clock. It is possible to set various frequencies at the two differential CLK\_ outputs with this configuration. For example, in 10 Gigabit Ethernet or SONET applications, set the dividing factors to generate the required frequencies, as shown in Table 1.

## Input Clock Monitor

### Failure Detection

The MAX9450/MAX9451/MAX9452 clock-failure-detection function monitors the two reference inputs simultaneously. If a reference input clock signal (IN\_) does not transition for two or more VCO cycles, the device reports a failure by setting INT high and bit CR7[6] or CR7[5] to 1. See Table 9. After a reference clock failure, the monitor switches to the other valid input reference. At the same time, the clock monitor loads CR7 with the status of the reference clocks and which input is selected. The mapping of CR7 is given in Table 9. If one of the inputs is disabled according to the bits in CR5[3:2], then the monitor is disabled.

### Revert Function

The response of the MAX9450/MAX9451/MAX9452 to a detected input failure depends on the setting of the revert function. If the failed input recovers from the failure, INT and CR7[5:6] resets to zero if revert is activated. If the recovered input is selected by CR5[4] as the default input reference, the MAX9450/MAX9451/MAX9452 reselect this input. If the revert function is not activated, once an input failure is detected, the monitor remains in the failure state with INT = 1 and CR7[5:6] = 1, until the MAX9450/MAX9451/MAX9452 are reset. Activate the revert function using the bit CR5[1].

### Failure-Detection Monitor Reset

Reset the fault by toggling  $\overline{CMON}$  from low to high, toggling MR or CR6[4] from low to high, or by toggling the bit CR5[0] from low to high. In revert mode, when the monitor is reset, INT and CR7[5:6] reset to zero and the default input is the one indicated by CR5[4].

### Holdover Function

The holdover function locks the output frequency to its nominal value within  $\pm 20$ ppm. Activate this function by setting CR6[7] to 1. The MAX9450/MAX9451/MAX9452 enter holdover when the devices detect a failure from both input references. Setting CR6[6] to 1 forces the device into the holdover state, while resetting CR6[6] exits holdover.

Use a reset holdover. If the revert function is activated once an input is recovered from the failure, the device also exits holdover and switches to the recovered input reference. If both inputs recover simultaneously, the device switches to the default input.

VCXO frequency during holdover is the value of the frequency right before the failure of inputs.

When CR6[5] goes from 0 to 1, the value of the VCXO frequency is acquired and stored. The VCXO can be switched to this acquired frequency by setting CR6[1] to 1. Such a transition can happen in both the normal mode of operation and the holdover mode.

### PLL Lock Detect

The MAX9450/MAX9451/MAX9452 also feature PLL lock detection. The MAX9450/MAX9451/MAX9452 compare the frequency of the phase-detector input with the output frequency of the loop frequency divider. When these two frequencies deviate more than 20ppm, the  $\overline{LOCK}$  output goes high. At power-up,  $\overline{LOCK}$  is high.  $\overline{LOCK}$  goes low when the PLL locks. PLL lock time also depends on the loop filter bandwidth.

**Table 1. Output Frequency Selection and Register Content Values**

10 GIGABIT ETHERNET				SONET					
INPUT CLK: 50MHz				INPUT CLK: 19.44MHz					
CRYSTAL FREQUENCY (MHz)	P	M	Ni	OUTPUT FREQUENCY (MHz)	CRYSTAL FREQUENCY (MHz)	P	M	Ni	OUTPUT FREQUENCY (MHz)
50	2	2	1	50	51.84	1	8	1	51.84
125	2	5	2	62.5	77.76	1	4	1	77.76
125	2	5	1	125	155.52	1	8	1	155.52
—	—	—	—	—	155.52	1	4	2	77.76

# High-Precision Clock Generators with Integrated VCXO

## External Loop Filter

When the device switches from one input reference to the other or reverts to an input reference from holdover, the output phase changes smoothly during the transition due to the narrowband external PLL filter. The narrower the filter bandwidth is, the smoother the phase transition. However, if bandwidth is too narrow, it can cause some degradation on output jitter performance.

## Charge-Pump Current Setting

The MAX9450/MAX9451/MAX9452 allow external setting of the charge-pump current in the PLL. Connect a resistor from RJ to GNDA to set the PLL charge-pump current:

$$\text{charge-pump current } (\mu\text{A}) = 2.48 \times 1000 / (\text{R}_{\text{SET}} (\text{k}\Omega) + 0.375)$$

where  $R_{\text{SET}}$  is in  $\text{k}\Omega$  and the value of the charge-pump current is in  $\mu\text{A}$ . Use  $R_{\text{SET}}$  to adjust the loop response to meet individual application requirements. The charge-pump current and the external filter components change the PLL bandwidth. Table 11 shows the charge-pump current vs. the resistor's value.

The loop response equation is defined as:

$$\text{unity-gain bandwidth} = (\text{I}_{\text{CP}} \times \text{R}_{\text{FILT}} \times 12\text{kHz}) / \text{M}$$

where  $\text{I}_{\text{CP}}$  is the charge-pump current set by REXT,  $\text{R}_{\text{FILT}}$  is the external filter resistance, and M is the feedback divider.

## Input Disable

The two inputs can be disabled separately by SEL0 and SEL1 or the 2 bits in CR5[3:2]. Table 2 shows the state map.

## Power-Up and Master Reset

Upon power-up, default frequency divider rates and the states of the monitor, inputs, and outputs are set according to Table 10. Setting MR high or CR6[4] to 1 also resets the device. When the device resets, INT and CR7[5:6] go low and all the registers revert to their default values.

**Table 2. Input Activation by SEL0, SEL1, or CR5[3:2]**

SEL1	SEL0	CR5[3:2]	IN1	IN0
0	0	00	Disabled	Disabled
0	1	00	Disabled	Enabled
1	0	00	Enabled	Disabled
1	1	00	Enabled	Enabled
X	X	01	Disabled	Enabled
X	X	10	Enabled	Disabled
X	X	11	Enabled	Enabled

## I<sup>2</sup>C Interface

The control interface of the MAX9450/MAX9451/MAX9452 is an I<sup>2</sup>C or SPI depending on the states of AD0 and AD1. Drive both AD0 and AD1 high to active SPI mode. Otherwise, I<sup>2</sup>C is activated. The device operates as a slave that sends and receives data through the clock line, SCL, and data line, SDA, to achieve bidirectional communication with the masters. A master (typically a microcontroller) initiates all data transfers to and from slaves, and generates the SCL clock that synchronizes the data transfer. Figure 4 shows the timing of SCL and SDA. The SDA line operates as both an input and an open-drain output. SDA requires a pullup resistor, typically 4.7k $\Omega$ . The SCL line operates only as an input. A pullup resistor, typically 4.7k $\Omega$ , is required on SCL if there are multiple masters on the 2-wire bus, or if the master in a single-master system has an open-drain SCL output.

## I<sup>2</sup>C Device Address

Every I<sup>2</sup>C port has a 7-bit device address. This 7-bit address is the slave (MAX9450/MAX9451/MAX9452) ID for the master to write and read. In the MAX9450/MAX9451/MAX9452, the first 4 bits (1101) of the address are hard coded into the device at the factory. See Table 3. The last 3 bits of the address are input programmable by the three-level AD0 and AD1. This configuration provides eight selectable addresses for the MAX9450/MAX9451/MAX9452, allowing eight devices to be connected to one master.

## START and STOP Conditions

Both SCL and SDA remain high when the interface is not busy. The active master signals the beginning of a transmission with a START (S) condition by transitioning SDA from high to low while SCL is high. When the master has finished communicating with the slave, it issues a STOP (P) condition by transitioning SDA from low to high while SCL is high. The bus is then free for another transmission (Figure 3). The interval between a START and a STOP is called a session.

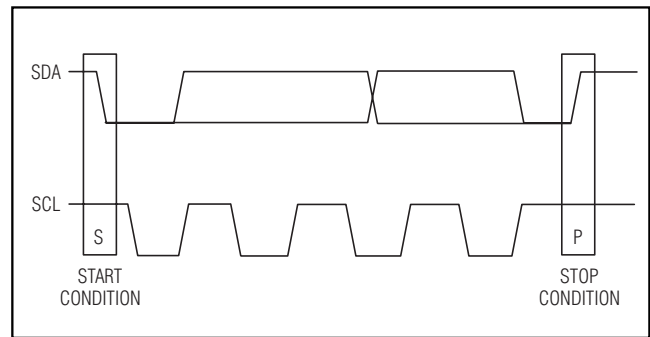

Figure 3. START and STOP Conditions

# High-Precision Clock Generators with Integrated VCXO

## Data Transfer and Acknowledge

Following the START condition, each SCL clock pulse transfers 1 bit. Between a START and a STOP, multiple bytes can be transferred on the 2-wire bus. The first 7 bits (B0–B6) are for the device address. The eighth bit (B7) indicates the writing (low) or reading (high) operation (W/R). The ninth bit (B8) is the ACK for the address and operation type. A low ACK bit indicates a successful transfer; otherwise, a high ACK bit indicates an unsuccessful transfer. The next 8 bits (register address), B9–B16, form the address byte for the control register to be written (Figure 4). The next bit, bit 17, is the ACK for the register address byte. The following byte (Data1)

is the content to be written into the addressed register of the slave. After this, the address counter of I<sup>2</sup>C is increased by 1 (Rgst Addr + 1) and the next byte (Data2) writes into a new register. To read the contents in the MAX9450/MAX9451/MAX9452s' control registers, the master sends the register address to be read to the slave by a writing operation. Then it sends the byte of device address + R to the slave. The slave (MAX9450/MAX9451/MAX9452) responds with the content bytes from the registers, starting from the pointed register to the last register, CR8, consecutively back to the master (Figures 5 and 6).

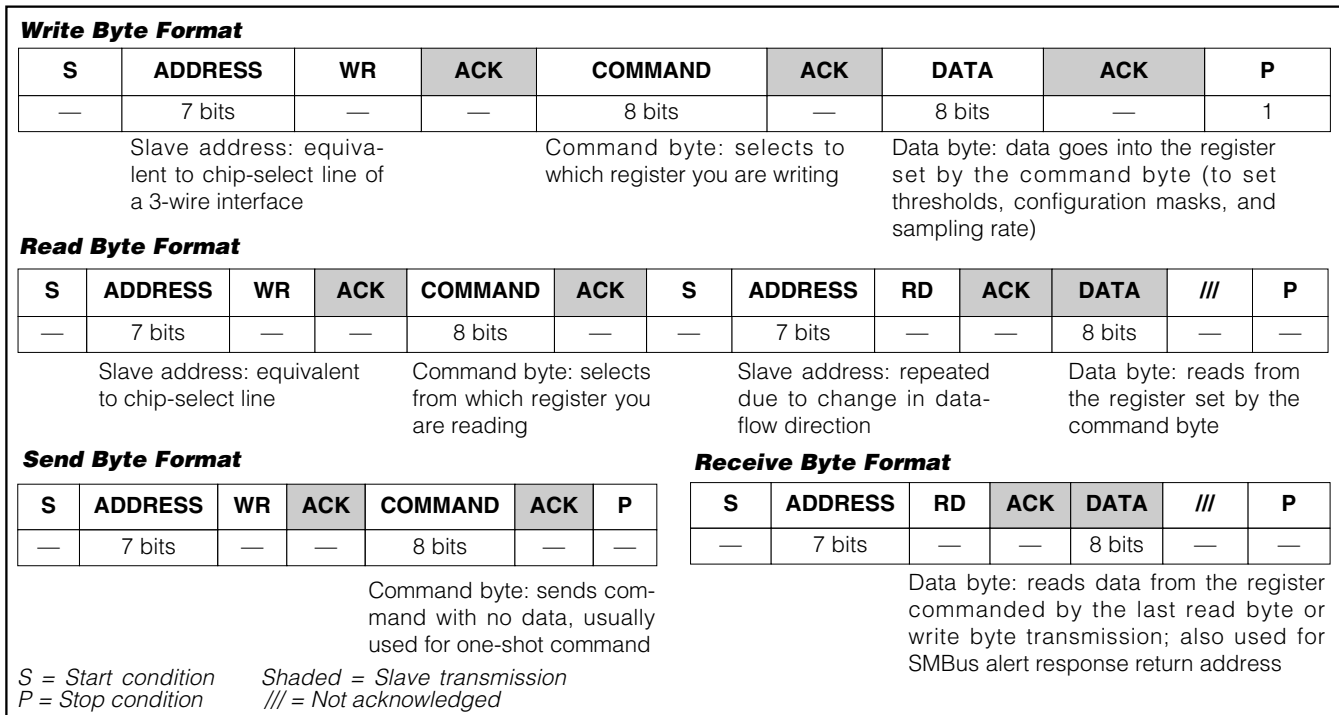

Figure 4. I<sup>2</sup>C Interface Data Structure

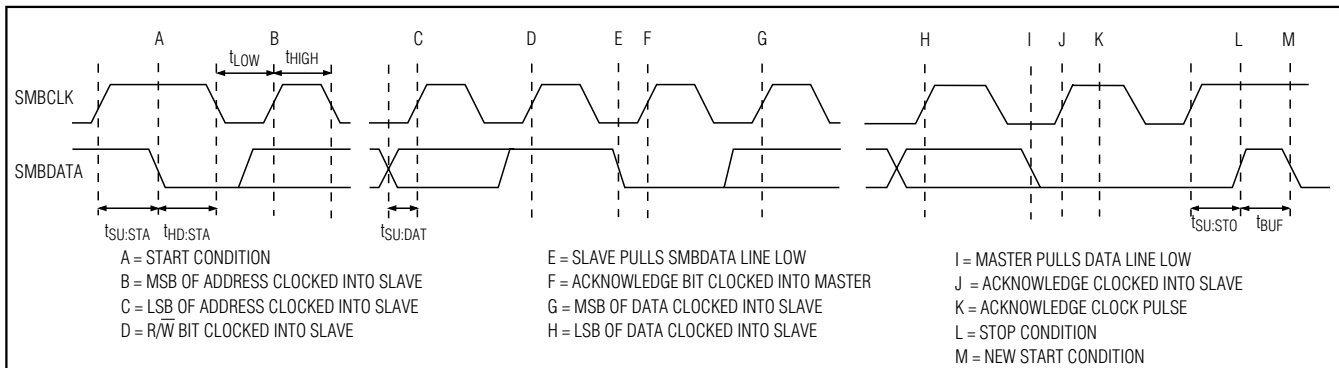

Figure 5. SMBus Write Timing Diagram

# High-Precision Clock Generators with Integrated VCXO

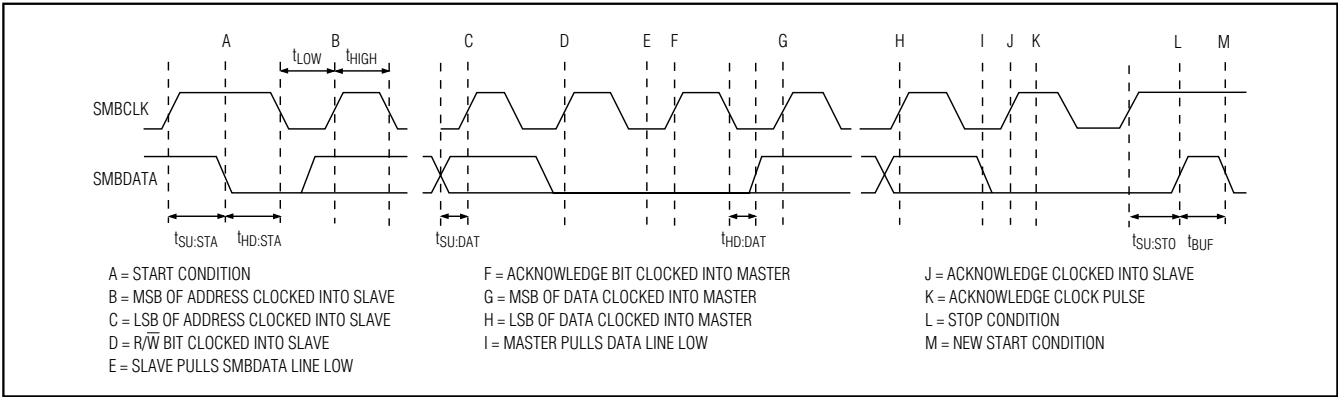

Figure 6. SMBus Read Timing Diagram

## SPI Interface

The SPI interface is activated when  $AD0 = AD1 = \text{high}$ . The SPI port is a write-only interface, and it uses the three inputs:  $\overline{CS}$ , SCLK, and SDA. Bit D15 is always zero, indicating the write-only mode, as shown in Figure 5. D14–D8 are the register address bits and D7–D0 are the data bits. In Table 4, the register address mapping is still valid, except the first address bit on the left is not used. D14 is the MSB of the address, and D7 is the MSB of the data. D15–D0 are sent with MSB (D15) first. The maximum SCLK frequency is 2MHz.

To perform a write, set D15 = 0, drive  $\overline{CS}$  low, toggle SCLK to latch SDA data on the rising edge, then drive  $\overline{CS}$  high after 16 SCLK cycles for two SCLK cycles to signal the boundary of a 16-bit word (Figure 5). SCLK must be low when  $\overline{CS}$  falls at the start of a transmission. Switching of SCLK and SDA is ignored unless  $\overline{CS}$  is low. Figure 7 shows the SPI write operation timing diagram and Figure 8 shows SPI register address and data configuration function setting tables.

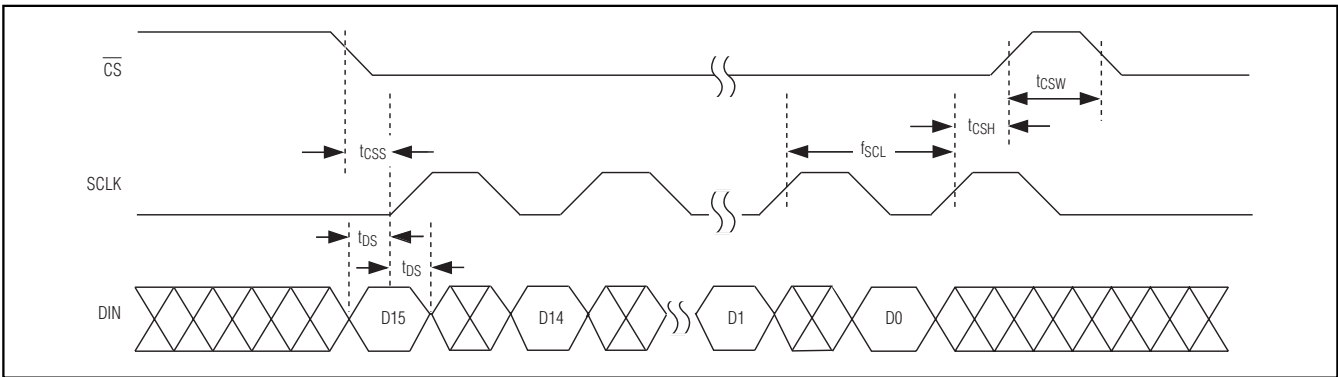

Figure 7. SPI Write Operation Timing Diagram

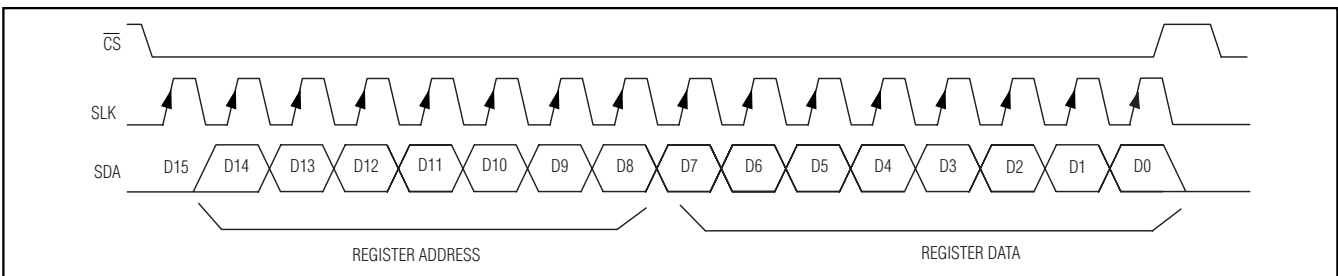

Figure 8. SPI Register Address and Data Configuration Function Setting Tables

# High-Precision Clock Generators with Integrated VCXO

MAX9450/MAX9451/MAX9452

**Table 3. I<sup>2</sup>C Address Setting by AD0 and AD1**

AD0	AD1	ADDRESS
Low	Low	1101000
Low	Open	1101001
Low	High	1101010
Open	Low	1101011
Open	Open	1101100
Open	High	1101101
High	Low	1101110
High	Open	1101111
High	High	Convert to SPI

**Table 4. I<sup>2</sup>C and SPI Register Address\***

REGISTER NAME	REGISTER ADDRESS	FUNCTION
CR0	00000000	P divider
CR1	00000001	M divider byte 1
CR2	00000010	M divider byte 2
CR3	00000011	N1 divider
CR4	00000100	N2 divider
CR5	00000101	Control
CR6	00000110	Control
CR7	00000111	Status
CR8	00001000	Reserved

\*When the SPI port is activated, the first address bit on the left is omitted and the remaining 7 bits are used. The LSB is the first bit on the right.

**Table 5. Dividing Rate Setting for P Divider**

CR0	DIVIDING RATE FOR P
0000-0000	1
0000-0001	2
—	—
1111-1110	255
1111-1111	256

**Table 6. Dividing Rate Setting for M Divider**

CR1	CR2[7:1]*	DIVIDING VALUE OF M
0000-0000	0000-000	1
0000-0000	0000-001	2
—	—	—
1111-1111	0011-110	8191
1111-1111	0011-111	8192
1111-1111	1111-111	32,768

\*CR2[0], the last LSB, is reserved.

**Table 7. Dividing Rate Setting for N0 and N1 Divider**

CR3*	DIVIDING VALUE OF N0	CR4*	DIVIDING VALUE OF N1
000XXXXX	1	000XXXXX	1
001XXXXX	2	001XXXXX	2
010XXXXX	3	010XXXXX	3
011XXXXX	4	011XXXXX	4
100XXXXX	5	100XXXXX	5
101XXXXX	6	101XXXXX	6
110XXXXX	8	110XXXXX	8
111XXXXX	16	111XXXXX	16

\*The last 5 LSBs of CR3[4:0] and CR4[4:0] are reserved.

# High-Precision Clock Generators with Integrated VCXO

**Table 8. Control Registers and Control Functions**

CR5, CR6	FUNCTION	STATE
CR5[7]	Output disable	0: Outputs are enabled 1: Outputs disabled to logic-low
CR5[6]	CLK0 enabling	0: CLK0 is disabled to high impedance (overrides CR5[7] = 1 setting) 1: CLK0 is enabled
CR5[5]	CLK1 enabling	0: CLK1 is disabled to high impedance (overrides CR5[7] = 1 setting) 1: CLK1 is enabled
CR5[4]	Default input setting	0: IN0 is the default input 1: IN1 is the default input
CR5[3:2]	Input enabling	00: The selection is controlled by SEL0, SEL1 (see Table 2) 01: Enable IN0, disable IN1 10: Enable IN1, disable IN0 11: Enable both IN0 and IN1
CR5[1]	Revert function	0: The function is not activated 1: The function is activated
CR5[0]	CLK monitor reset	CLK monitor is reset in revert mode: INT = 0 and CR7[7] = 0, and the PLL switches to the default input
CR6[7]	Holdover function enabling	0: Holdover function is disabled 1: Holdover function is enabled
CR6[6]	Forced holdover	0: Holdover is in normal mode 1: Holdover is forced to be activated As the bit goes from 0 to 1, the current VCXO frequency is taken as the nominal value
CR6[5]	Acquiring nominal VCXO frequency	As this bit is toggling from 0 to 1, the current VCXO frequency is taking as the nominal holdover value
CR6[4]	Master reset	The bit acts at the same as the input MR; CR6[4] = 1, the chip is reset
CR6[3]	REF	This bit is always set to zero
CR6[2]	ODIV select	CR6[2] = 0: DIV0 output drives CLK2 CR6[2] = 1: DIV1 output drives CLK2
CR6[1]	Acquire select	CR6[1] = 0 PLL controls the Xtal frequency CR6[1] = 1 Xtal frequency is controlled by the acquired value (acquired at rising edge of CR6[5])
CR6[0]	Reserved	—

**Table 9. Mapping for the Input Monitor Status**

CR7	FUNCTION	STATE
CR7[6]	Status of IN0	0: Normal
CR7[5]	Status of IN1	1: Failure detected
CR7[4]	Input clock selection indicator	0: IN0 is currently used 1: IN1 is currently used
CR7[3]	LOCK indicator	1: PLL not locked 0: PLL locked
CR7[2]	Holdover status	1: Device is in holdover state 0: Device is in normal state
CR7[1:0]	Reserved	—

**Table 10. Register Default Values at Power-Up**

REGISTER	ACTION	DEFAULT
CR0	P = 1	00000000
CR1	M = 1	00000000
CR2	M = 1	00000000
CR3	N0 = 1	00000000
CR4	N1 = 1	00000000
CR5, CR6	1. Outputs enable 2. IN0 is the default input 3. Both inputs are enabled by SEL0 and SEL1 4. Monitor is nonrevertive 5. Holdover is disabled	CR5: 01100000 CR6: 00000000
CR7	Status	00000000
CR8	Reserved	00000000

# High-Precision Clock Generators with Integrated VCXO

MAX9450/MAX9451/MAX9452

**Table 11. Resistor Value vs. Charge-Pump Current**

RESISTOR (k $\Omega$ )	CURRENT ( $\mu$ A)
12	200.5
20	121.88
50	49.41
100	24.86
150	16.61
200	12.48

## Applications Information

### Crystal Selection

The MAX9450/MAX9451/MAX9452 internal VCXO circuitry requires an external crystal. The frequency of the crystal ranges from 15MHz to 160MHz, depending on the application. It is important to use a quartz crystal that prevents reduction of the frequency pulling range, temperature stability, or excessive output phase jitter. Choose an AT-cut crystal that oscillates at the required frequency on its fundamental mode with a variation of 25ppm, including frequency accuracy and operating temperature range. Select a crystal with a load capacitance of 8pF and a motional capacitance of at least 7fF to achieve the specified pulling range.

Crystals from manufacturers KDS ([www.kdsj.co.jp](http://www.kdsj.co.jp)) and 4Timing ([www.4timing.com](http://www.4timing.com)) are recommended.

### LVDS Cables and Connectors

The interconnect for LVDS typically has a 100 $\Omega$  differential impedance. Use cables and connectors that have matched differential impedance to minimize impedance discontinuities.

Twisted-pair and shielded twisted-pair cables offer superior signal quality compared to ribbon cable and tend to generate less EMI due to magnetic-field-canceling effects.

### Power-Supply Bypassing

Bypass  $V_{DDA}$ ,  $V_{DD}$ , and  $V_{DDQ}$  to ground with high-frequency, surface-mount ceramic 0.1 $\mu$ F and 0.01 $\mu$ F capacitors. Place the capacitors as close as possible to the device with the 0.01 $\mu$ F capacitor closest to the device pins.

### Board Layout

Circuit-board trace layout is very important to maintain the signal integrity of high-speed differential signals. Maintaining integrity is accomplished in part by reducing signal reflections and skew and increasing common-mode noise immunity.

Signal reflections are caused by discontinuities in the 50 $\Omega$  (100 $\Omega$  for LVDS outputs) characteristic impedance of the traces. Avoid discontinuities by maintaining the distance between differential traces, not using sharp corners or vias. Ensure the two traces are parallel and close to each other to increase common-mode noise immunity and reduce EMI. Matching the electrical length of the differential traces further reduces signal skew.

### Output Termination

Terminate the MAX9450 outputs with 50 $\Omega$  to  $V_{CC} - 2V$  or use an equivalent thevenin termination. When a single-ended signal is taken from a differential output, terminate both outputs.

The MAX9452 outputs are specified for a 100 $\Omega$  load, but can drive 90 $\Omega$  to 132 $\Omega$  to accommodate various types of interconnects. The termination resistor at the driven receiver should match the differential characteristic impedance of the interconnect and be located close to the receiver input. Use a  $\pm 1\%$  surface-mount termination resistor.

## Chip Information

PROCESS: CMOS

# High-Precision Clock Generators with Integrated VCXO

## Package Information

(The package drawing(s) in this data sheet may not reflect the most current specifications. For the latest package outline information go to [www.microsemi.com](http://www.microsemi.com).)

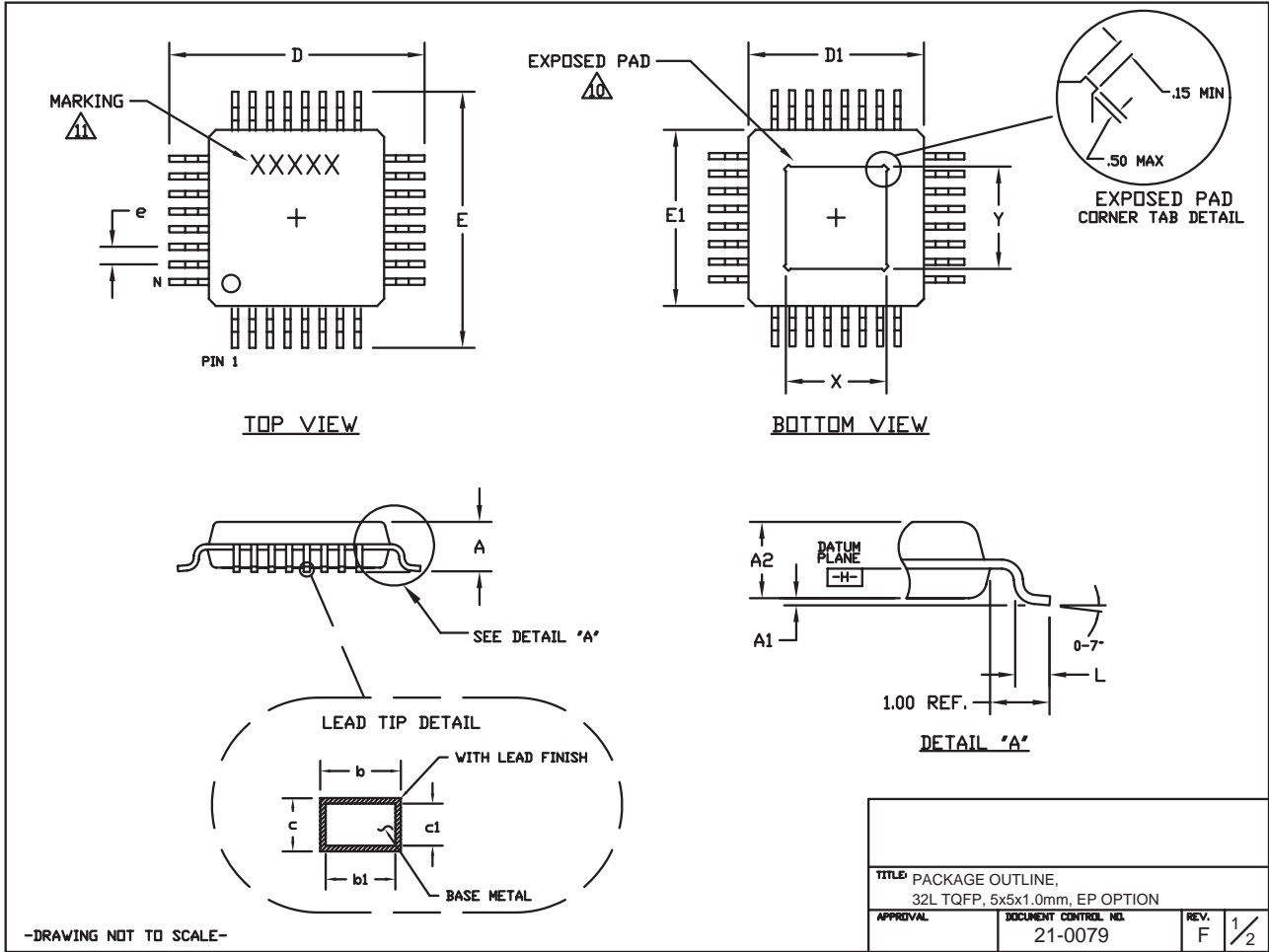

32L TQFP.EPS

# High-Precision Clock Generators with Integrated VCXO

## Package Information (continued)

MAX9450/MAX9451/MAX9452

### NOTES:

1. ALL DIMENSIONING AND TOLERANCING CONFORM TO ANSI Y14.5-1982.
  2. DATUM PLANE [EH] IS LOCATED AT MOLD PARTING LINE AND COINCIDENT WITH LEAD, WHERE LEAD EXITS PLASTIC BODY AT BOTTOM OF PARTING LINE.
  3. DIMENSIONS D1 AND E1 DO NOT INCLUDE MOLD PROTRUSION. ALLOWABLE MOLD PROTRUSION IS 0.25 MM ON D1 AND E1 DIMENSIONS.
  4. THE TOP OF PACKAGE IS SMALLER THAN THE BOTTOM OF PACKAGE BY 0.15 MILLIMETERS.
  5. DIMENSION b DOES NOT INCLUDE DAMBAR PROTRUSION. ALLOWABLE DAMBAR PROTRUSION SHALL BE 0.08 MM TOTAL IN EXCESS OF THE b DIMENSION AT MAXIMUM MATERIAL CONDITION.
  6. ALL DIMENSIONS ARE IN MILLIMETERS.
  7. THIS OUTLINE CONFORMS TO JEDEC PUBLICATION 95, REGISTRATION MS-026.
  8. LEADS SHALL BE COPLANAR WITHIN .004 INCH.
  9. EXPOSED DIE PAD SHALL BE COPLANAR WITH BOTTOM OF PACKAGE WITHIN 2 MILS (.05 MM).
- ⚠ DIMENSIONS X AND Y APPLY TO EXPOSED PAD (EP) VERSIONS ONLY. SEE INDIVIDUAL PRODUCT DATASHEET TO DETERMINE IF A PRODUCT USES EXPOSED PAD PACKAGE.
- ⚠ MARKING IS FOR PACKAGE ORIENTATION REFERENCE ONLY.

COMMON DIMENSIONS		
DIMENSIONS IN MILLIMETERS		
JEDEC AAA-HD		
5x5x1.0 MM		
	MIN.	MAX.
A	<i>~</i>	1.20
A <sub>1</sub>	0.05	0.15
A <sub>2</sub>	0.95	1.05
D	6.80	7.20
D <sub>1</sub>	4.80	5.20
E	6.80	7.20
E <sub>1</sub>	4.80	5.20
L	0.45	0.75
N	32	
e	0.50 BSC.	
b	0.17	0.27
b1	0.17	0.23
c	0.09	0.20
c1	0.09	0.16
X	2.70	3.30
Y	2.70	3.30

-DRAWING NOT TO SCALE-

TITLE: PACKAGE OUTLINE,  
32L TQFP, 5x5x1.0mm, EP OPTION

APPROVAL	DOCUMENT CONTROL NO. 21-0079	REV. F	2/2
----------	---------------------------------	-----------	-----

# High-Precision Clock Generators with Integrated VCXO

## Revision History

REVISION NUMBER	REVISION DATE	REVISION DESCRIPTION	PAGES CHANGED
0	—	Initial release	—
1	—	Various changes	—
2	9/06	Various changes	1-4, 7-10, 12, 15, 16
3	11/07	Fixed typo in crystal frequency range ( <i>Functional Diagram</i> )	7



**Microsemi Corporate Headquarters**  
One Enterprise, Aliso Viejo CA 92656 USA  
Within the USA: +1 (949) 380-6100  
Sales: +1 (949) 380-6136  
Fax: +1 (949) 215-4996

Microsemi Corporation (NASDAQ: MSCC) offers a comprehensive portfolio of semiconductor solutions for: aerospace, defense and security; enterprise and communications; and industrial and alternative energy markets. Products include high-performance, high-reliability analog and RF devices, mixed signal and RF integrated circuits, customizable SoCs, FPGAs, and complete subsystems. Microsemi is headquartered in Aliso Viejo, Calif. Learn more at [www.microsemi.com](http://www.microsemi.com).

---

© 2012 Microsemi Corporation. All rights reserved. Microsemi and the Microsemi logo are trademarks of Microsemi Corporation. All other trademarks and service marks are the property of their respective owners.

## Looking for pricing, stock, or lifecycle information?

Click below to explore more details on WIN SOURCE:

- ⊖ [View MAX9452EHJ on WIN SOURCE](#)
- ⊖ [Microchip Technology Information](#)

## Optimize Your Supply Chain with WIN SOURCE Solutions

- ✓ Global Sourcing Solution
- ✓ Obsolete Management
- ✓ Cost Control Management
- ✓ Shortage Management
- ✓ Alternative Solution
- ✓ Excess Inventory Management