



**THE DATASHEET OF  
MAX8688BHETG+**



EVALUATION KIT  
AVAILABLE

# Digital Power-Supply Controller/Monitor with PMBus Interface

MAX8688

## General Description

The MAX8688 fully integrated digital power-supply controller and monitor IC works with any existing POL (point-of-load) power supply to provide complete digital programmability. By interfacing to the reference input, feedback node, and output enable, the MAX8688 takes control of the POL to provide functions such as perfect tracking, sequencing, margining, and dynamic adjustment of the output voltage.

The MAX8688 offers an accurate 12-bit analog-to-digital converter (ADC) accompanied with two differential amplifiers for accurately monitoring both voltage and current. An integrated 12-bit digital-to-analog converter (DAC) is also available to margin power supplies as well as dynamically adjust the output voltage with 0.2% accuracy over temperature using this closed-loop system. An internal temperature sensor provides an additional level of system monitoring.

The user-programmable registers provide flexible and accurate control of time events such as a delay time and transition period, monitoring for overvoltage and undervoltage, overcurrent, reverse-current, overtemperature fault and warning handling. The closed-loop operation is also programmable to make sure the MAX8688 works with any existing POL to provide superior regulation accuracy and accurate margining.

The MAX8688 operates using a PMBus™-compliant communication protocol. The device is programmed using this protocol or simply with the use of a free graphic-user interface (GUI) available from the Maxim website that significantly reduces development time. Once the configuration is complete, the results can be saved into an EEPROM or loaded onto the part through the PMBus at power-up. This allows remote configuration of any POL using the MAX8688, replacing expensive recalls or field service. Module current sharing is also supported, since accurate current measurement and fine resolution voltage control are available. The MAX8688 can be programmed with up to 127 distinct addresses to support large systems. The MAX8688 is offered in a space-saving, 24-pin, lead-free 4mm x 4mm TQFN package.

## Applications

Telecom Networking  
DC-DC Modules and POLs  
Servers  
High-Reliability Infrastructure Equipment

PMBus is a trademark of SMIF, Inc.



## Features

- ◆ PMBus Interface for Programming, Monitoring, Sequencing Up and Down, and Accurate Output-Voltage Control
- ◆ Controls Output Voltage with 0.2% Accuracy for Line, Load, and Temperature Variations
- ◆ Output Voltage, Output Current, and Temperature Monitoring with Adjustable Monitor Rate
- ◆ Current Measurement with 2.6% Accuracy
- ◆ Programmable Soft-Start and Soft-Stop Ramp Rates
- ◆ Controls Up to 26 Power Supplies with Hardwired Address Pins and Up to 127 POLs with Software Addressing
- ◆ Compatible with REFIN and FB Terminals of POL Power Supplies
- ◆ Protection for POL Against Overvoltage, Undervoltage, Overcurrent, Negative Current and Overtemperature Faults with No Action, Latch and Retry (Hiccup) Options
- ◆ Open-Drain  $\overline{\text{FLT}}$  Signal for Fault Detection
- ◆ Master-Slave Clocking Option Eliminates External Clock Requirement and Provides Accurate Timing Reference
- ◆ External EEPROM Interface for Auto-Programming on Power-Up

## Ordering Information

PART	TEMP RANGE	PIN-PACKAGE
MAX8688ALETG+	-40°C to +85°C	24 TQFN-EP*
MAX8688AHETG+	-40°C to +85°C	24 TQFN-EP*
MAX8688BLETG+	-40°C to +85°C	24 TQFN-EP*
MAX8688BHETG+	-40°C to +85°C	24 TQFN-EP*

+Denotes a lead(Pb)-free/RoHS-compliant package.

\*EP = Exposed pad.

## Selector Guide

PART	ACCURACY (%)	ENOUT POWER-UP DEFAULT STATE
MAX8688ALETG+	0.2	Low
MAX8688AHETG+	0.2	High
MAX8688BLETG+	0.4	Low
MAX8688BHETG+	0.4	High

Pin Configuration appears at end of data sheet.

# Digital Power-Supply Controller/Monitor with PMBus Interface

## ABSOLUTE MAXIMUM RATINGS

AVDD, DVDD to AGND	-0.3V to +4.5V
DGND to AGND	±0.3V
RS+, RS-, ISN+, ISN- to AGND	-0.3V to +6V
RS_C, ISN_C, A1/SCLE, A2/SDAE, A3/ONOFF to AGND	-0.3V to (V <sub>AVDD</sub> + 0.3V)
DACOUT to AGND	-0.3V to (V <sub>AVDD</sub> + 0.3V)
REFO to AGND	-0.3V to +4.5V
Continuous Power Dissipation (T <sub>A</sub> = +70°C) 24-Pin TQFN (derate 27.8mW/°C above +70°C)	2222mW*

SCL, SDA, CLKIO, $\overline{\text{RST}}$ to DGND	-0.3V to +4.5V
ENOUT, $\overline{\text{FLT}}$ to DGND	-0.3V to +6V
Thermal Resistance from Junction to Exposed Pad	2.7°C/W
Operating Temperature	-40°C to +85°C
Junction Temperature	+150°C
Storage Temperature	-65°C to +150°C
Lead Temperature (soldering, 10s)	+300°C
Soldering Temperature (reflow) (Note 1)	+260°C

**Note 1:** Hand soldering not recommended.

Stresses beyond those listed under "Absolute Maximum Ratings" may cause permanent damage to the device. These are stress ratings only, and functional operation of the device at these or any other conditions beyond those indicated in the operational sections of the specifications is not implied. Exposure to absolute maximum rating conditions for extended periods may affect device reliability.

## PACKAGE THERMAL CHARACTERISTICS (Note 2)

24 TQFN-EP

Junction-to-Ambient Thermal Resistance ( $\theta_{JA}$ )	36°C/W
Junction-to-Case Thermal Resistance ( $\theta_{JC}$ )	2.7°C/W

**Note 2:** Package thermal resistances were obtained using the method described in JEDEC specification JESD51-7, using a four-layer board. For detailed information on package thermal considerations, refer to [www.maxim-ic.com/thermal-tutorial](http://www.maxim-ic.com/thermal-tutorial).

## ELECTRICAL CHARACTERISTICS

(V<sub>AVDD</sub> = V<sub>DVDD</sub> = 3.3V, T<sub>A</sub> = T<sub>J</sub> = -40°C to +85°C, V<sub>RS+</sub> - V<sub>RS-</sub> = 2V, V<sub>RS-</sub> = V<sub>AGND</sub>, unless otherwise stated.) (Note 3)

PARAMETER	SYMBOL	CONDITIONS	MIN	TYP	MAX	UNITS
<b>GENERAL</b>						
AVDD/DVDD Operating Range			3.0		3.6	V
AVDD and DVDD Operating Supply Current		V <sub>RS+</sub> = V <sub>RS-</sub> = V <sub>ISN+</sub> = V <sub>ISN-</sub> = V <sub>AGND</sub>		6.7	8.5	mA
AVDD UVLO		Rising	2.70	2.8	2.95	V
		Hysteresis		100		mV
<b>OUTPUT-VOLTAGE SENSING</b>						
Voltage Regulation Accuracy (2V Range, Table 8) (Note 4)		MAX8688A, T <sub>A</sub> = 0°C to +85°C, V <sub>RS+</sub> = 1V, V <sub>RS-</sub> = 0V	-0.2		+0.2	%
		MAX8688A, T <sub>A</sub> = -40°C to +85°C, V <sub>RS+</sub> = 1V, V <sub>RS-</sub> = 0V	-0.3		+0.3	
		MAX8688B, T <sub>A</sub> = 0°C to +85°C, V <sub>RS+</sub> = 1V, V <sub>RS-</sub> = 0V	-0.4		+0.4	
		MAX8688B, T <sub>A</sub> = -40°C to +85°C, V <sub>RS+</sub> = 1V, V <sub>RS-</sub> = 0V	-0.5		+0.5	
Voltage Regulation Accuracy (5.5V range, Table 8) (Note 4)		MAX8688A, T <sub>A</sub> = 0°C to +85°C, V <sub>RS+</sub> = 2.5V, V <sub>RS-</sub> = 0V	-0.3		+0.3	%
		MAX8688A, T <sub>A</sub> = -40°C to +85°C, V <sub>RS+</sub> = 2.5V, V <sub>RS-</sub> = 0V	-0.4		+0.4	
		MAX8688B, T <sub>A</sub> = 0°C to +85°C, V <sub>RS+</sub> = 2.5V, V <sub>RS-</sub> = 0V	-0.4		+0.4	
		MAX8688B, T <sub>A</sub> = -40°C to +85°C, V <sub>RS+</sub> = 2.5V, V <sub>RS-</sub> = 0V	-0.5		+0.5	
RS+, RS- Differential Mode Range			0		5.5	V

# Digital Power-Supply Controller/Monitor with PMBus Interface

MAX8688

## ELECTRICAL CHARACTERISTICS (continued)

( $V_{AVDD} = V_{DVDD} = 3.3V$ ,  $T_A = T_J = -40^{\circ}C$  to  $+85^{\circ}C$ ,  $V_{RS+} - V_{RS-} = 2V$ ,  $V_{RS-} = V_{AGND}$ , unless otherwise stated.) (Note 3)

PARAMETER	SYMBOL	CONDITIONS	MIN	TYP	MAX	UNITS
RS- to AGND Differential Voltage			-250		+250	mV
RS+ Input Bias Current		2V range, $V_{RS+} = -0.25V$ to $+2V$	-10		+15	$\mu A$
		5.5V range, $V_{RS+} = -0.25V$ to $+5.5V$	-10		+60	
RS- Input Bias Current		2V or 5.5V range, $V_{RS-} = -0.25V$ to $+0.25V$	-10		0	$\mu A$
<b>OUTPUT CURRENT SENSE</b>						
Current-Sense Accuracy (Note 4)		$V_{ISN+} = 1V$ , $V_{ISN+} - V_{ISN-} = 20mV$ , $T_A = +25^{\circ}C$ to $+85^{\circ}C$	-2.6		+2.6	%
		$V_{ISN+} = 1V$ , $V_{ISN+} - V_{ISN-} = 20mV$ , $T_A = -40^{\circ}C$ to $+85^{\circ}C$	-7		+7	
ISN+, ISN- Common-Mode Range			0		5.5	V
ISN+, ISN- Common-Mode Current-Sense Error		$V_{CM} = 0$ to $5.5V$ , $V_{DM} = 20mV$		0.9		%
ISN+, ISN- Differential Mode Range			-10		+40	mV
ISN+, ISN- Input Bias Current		$V_{ISN+}$ , $V_{ISN-}$ to $V_{AGND} = 0V$ or $5.5V$	-20		+40	$\mu A$
<b>RS_C, ISN_C</b>						
RS_C, ISN_C Output Impedance				0.2		k $\Omega$
<b>TEMPERATURE SENSING</b>						
Temperature Sensing Accuracy		Exposed pad = $-40^{\circ}C$ to $+100^{\circ}C$		$\pm 3$		$^{\circ}C$
<b>CLKIO</b>						
CLKIO Input-Logic Low Voltage					0.8	V
CLKIO Input-Logic High Voltage			2.1			V
CLKIO Input Bias Current		$V_{CLKIO} = 0V$ or $3.6V$	-1		+1	$\mu A$
CLKIO Input Clock Duty Cycle		$f_{CLKIO} = 100kHz$ to $2500kHz$	20		80	%
CLKIO Output Low Voltage		CLKIO in output mode, $I_{SINK} = 4mA$			0.4	V
CLKIO Output High Leakage		$V_{CLKIO} = V_{DVDD} = V_{AVDD} = 3.6V$	-1		+1	$\mu A$
CLKIO Input/Output Clock Rise Time		$R_{PULLUP} = 560\Omega$ , $C_{LOAD} = 20pF$		20		ns
CLKIO Input/Output Clock Fall Time		$R_{PULLUP} = 560\Omega$ , $C_{LOAD} = 20pF$		2		ns
CLKIO Pullup Voltage					DVDD	V
CLKIO Input Frequency	$f_{EXT\_CLK}$		100		2500	kHz
CLKIO Output Frequency Accuracy			0.95	1.00	1.05	MHz
<b>ENOUT, FLT OPEN-DRAIN LOGIC OUTPUTS</b>						
ENOUT, FLT Output Low Voltage		$I_{SINK} = 4mA$			0.4	V
ENOUT, FLT Output High Leakage		$V_{ENOUT} = V_{FLT} = 5.5V$ , $V_{DVDD} = V_{AVDD} = 3.6V$	-1		+1	$\mu A$
ENOUT, FLT Pullup Voltage					5.5	V

# Digital Power-Supply Controller/Monitor with PMBus Interface

## ELECTRICAL CHARACTERISTICS (continued)

( $V_{AVDD} = V_{DVDD} = 3.3V$ ,  $T_A = T_J = -40^{\circ}C$  to  $+85^{\circ}C$ ,  $V_{RS+} - V_{RS-} = 2V$ ,  $V_{RS-} = V_{AGND}$ , unless otherwise stated.) (Note 3)

PARAMETER	SYMBOL	CONDITIONS	MIN	TYP	MAX	UNITS
<b>DAC</b>						
DAC Resolution				12		bits
DAC Output-Voltage Range		No load		REFO - 1 LSB		V
DAC Output-Voltage Slew Rate				0.6		V/ $\mu$ s
DAC Output Resistance				5		$\Omega$
DAC Driving Capability				2		mA
<b>ADC</b>						
ADC Resolution		MAX8688A		12		Bits
		MAX8688B		11		
<b>THREE-STATE ADDRESS PINS (A3/ONOFF, A2/SDAE, A1/SCLE)</b>						
Three-State Address Pins Input Low Voltage					0.3	V
Three-State Address Pins Input Low Threshold Hysteresis				50		mV
Three-State Address Pins Input High Voltage			AVDD - 0.4			V
Three-State Address Pins Input High Threshold Hysteresis				50		mV
Three-State Address Pins Input Bias Current		$V_{AVDD} = 3.6V$ , A3/ONOFF = A2/SDAE = A1/SCLE = AVDD or AGND	-12		+12	$\mu$ A
<b>THREE-STATE ADDRESS PINS (A2/SDAE (DATA) AND A1/SCLE (CLOCK) WITH EEPROM) (Note 5)</b>						
A2/SDAE, A1/SCLE Output Low Voltage		Output sink current = 100 $\mu$ A (Note 6)			0.3 x AVDD	V
A2/SDAE, A1/SCLE Output High Voltage		Output source current = 100 $\mu$ A (Note 7)	0.7 x AVDD			V
<b>THREE-STATE ADDRESS PIN (A3/ONOFF AS POL ON/OFF CONTROL)</b>						
Minimum A3/ONOFF Control Pulse Low Time	$t_{A3\_LOW}$			250		$\mu$ s
Minimum A3/ONOFF Control Pulse High Time	$t_{A3\_HIGH}$			750		$\mu$ s
<b>SCL, SDA SMBus™ SIGNALS</b>						
Maximum SMBus Speed				100		kHz
SCL, SDA Input Low Voltage	$V_{SMB\_IL}$	$V_{DVDD} = 3.0V$ to $3.6V$			0.8	V
SCL, SDA Input High Voltage	$V_{SMB\_IH}$	$V_{DVDD} = 3.0V$ to $3.6V$	2.1		DVDD	V
SCL, SDA Output Low Voltage	$V_{SMB\_OL}$	$V_{DVDD} = 3.0V$ to $3.6V$ at $I_{SINK} = 4mA$			0.4	V
SCL, SDA Input Leakage Per Device Pin	$I_{SMB\_ILEAK}$	$V_{DVDD} = 3.6V$ , $V_{SCL} = V_{SDA} = 0$ or $3.6V$	-1		+1	$\mu$ A

SMBus is a trademark of Intel Corp.

# Digital Power-Supply Controller/Monitor with PMBus Interface

MAX8688

## ELECTRICAL CHARACTERISTICS (continued)

( $V_{AVDD} = V_{DVDD} = 3.3V$ ,  $T_A = T_J = -40^{\circ}C$  to  $+85^{\circ}C$ ,  $V_{RS+} - V_{RS-} = 2V$ ,  $V_{RS-} = V_{AGND}$ , unless otherwise stated.) (Note 3)

PARAMETER	SYMBOL	CONDITIONS	MIN	TYP	MAX	UNITS
<b>RST INPUT</b>						
RST Input Low Voltage	$V_{RST\_IL}$	$V_{DVDD} = 3.0V$ to $3.6V$			0.8	V
RST Input High Voltage	$V_{RST\_IH}$	$V_{DVDD} = 3.0V$ to $3.6V$	2.1			V
RST Input Bias Current		RST = DVDD or DGND			10	$\mu A$
Minimum SMBus Interface Reset Pulse Width	$t_{SMB\_RST}$		1		455	$\mu s$
SMBus Interface Recovery Time After Interface Reset	$t_{SMB\_WAIT}$			15		$\mu s$
Minimum Reset Pulse Width	$t_{RST}$		565			$\mu s$
Recovery Time After Device Reset	$t_{RST\_WAIT}$			15		$\mu s$
<b>OTHER TIMING PARAMETERS</b>						
PMBus Command Response Time	$t_{PMB\_RSP}$			300		$\mu s$
Fault Response Time	$t_{FAULT\_RSP}$	Overvoltage fault		5		ms
		Overcurrent fault		5		

**Note 3:** Production tested at  $T_A = +25^{\circ}C$  and  $T_A = +85^{\circ}C$ . Specifications from  $T_A = -40^{\circ}C$  to  $+25^{\circ}C$  are guaranteed by design, unless otherwise noted.

**Note 4:** Production tested at  $T_A = +85^{\circ}C$  only. All other temperatures are guaranteed by design.

**Note 5:** When an EEPROM is connected to A2/SDAE and A1/SCLE, these pins cannot be hardwired to ground or supply. They must be connected through  $33k\Omega \pm 5\%$  resistors.

**Note 6:** Equivalent of having  $33k\Omega$  pull-down resistor to DGND.

**Note 7:** Equivalent of having  $33k\Omega$  pull-up resistor to DVDD.

## Typical Operating Characteristics

( $V_{AVDD} = V_{DVDD} = 3.3V$ ,  $T_A = +25^{\circ}C$ , unless otherwise noted.)

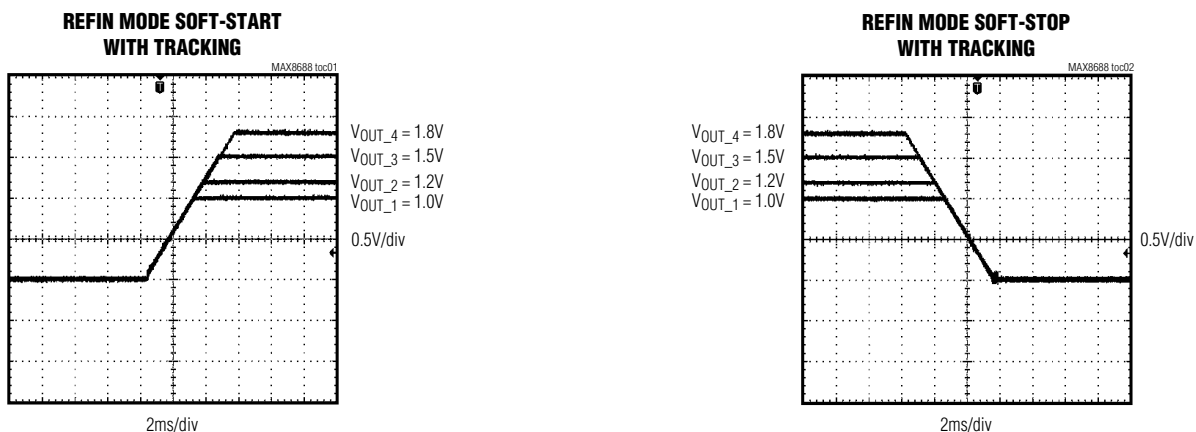

# Digital Power-Supply Controller/Monitor with PMBus Interface

## Typical Operating Characteristics (continued)

( $V_{AVDD} = V_{DVDD} = 3.3V$ ,  $T_A = +25^\circ C$ , unless otherwise noted.)

**REFIN MODE SOFT-START WITH SEQUENCING**

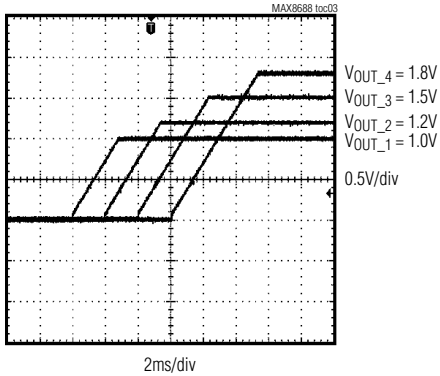

**REFIN MODE SOFT-STOP WITH SEQUENCING**

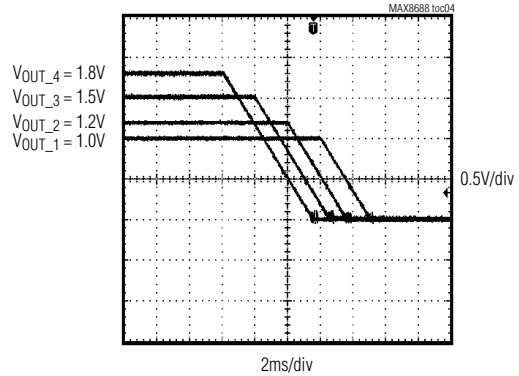

**REFIN MODE IMMEDIATE OFF WITH SEQUENCING**

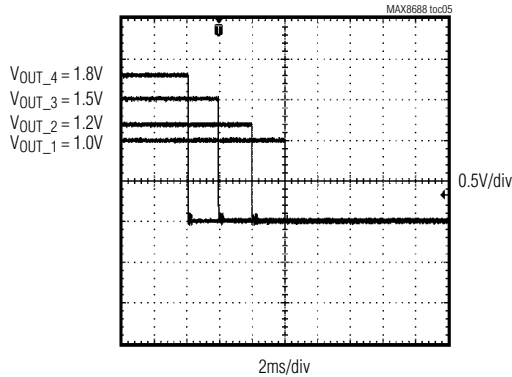

**REFIN MODE SOFT-START FROM A3 WITH SEQUENCING**

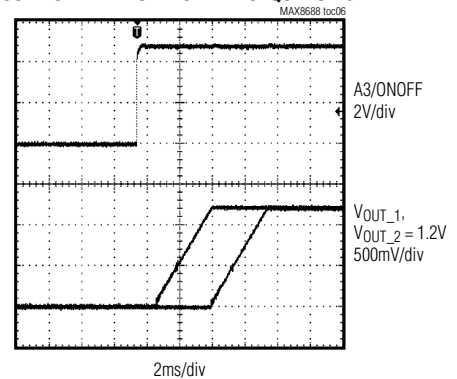

**REFIN MODE SOFT-STOP FROM A3 WITH SEQUENCING**

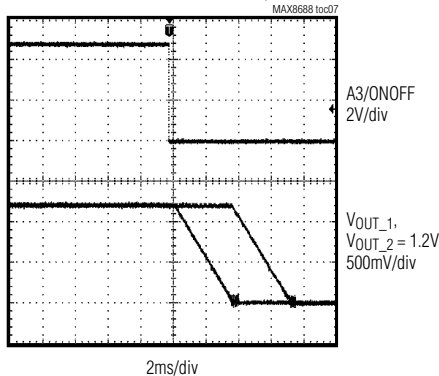

# Digital Power-Supply Controller/Monitor with PMBus Interface

## Typical Operating Characteristics (continued)

( $V_{AVDD} = V_{DVDD} = 3.3V$ ,  $T_A = +25^\circ C$ , unless otherwise noted.)

MAX8688

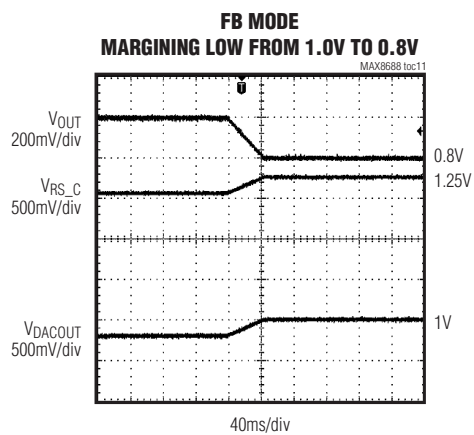
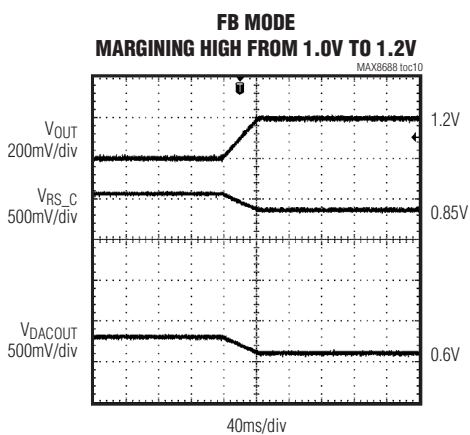
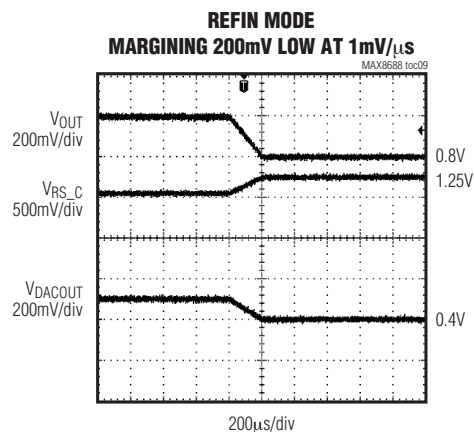
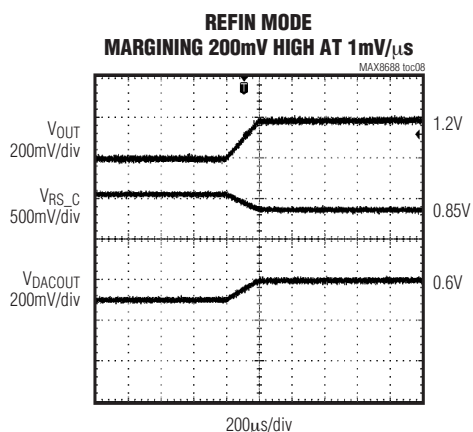

# Digital Power-Supply Controller/Monitor with PMBus Interface

## Pin Description

PIN	NAME	FUNCTION
1, 3	DVDD	Digital Power-Supply Input (3.3V, typ). Connect AVDD to DVDD externally. Connect a 0.1µF capacitor from DVDD to DGND.
2	DGND	Digital Ground. Connect AGND to DGND externally close to the device.
4	CLKIO	Clock Input/Output. User-configurable clock input/output signal. The system controller can provide a clock input to synchronize the time bases of multiple MAX8688 devices. Alternatively, a MAX8688 can provide a 1MHz output clock to other MAX8688s for synchronization. See the <i>MFR_MODE (D1h)</i> section.
5	$\overline{\text{RST}}$	Active-Low SMBus Interface and Device Reset Line. Active-low logic input. See the <i><math>\overline{\text{RST}}</math> Operation</i> section.
6	SDA	SMBus Data Line
7	SCL	SMBus Clock Line
8, 9	N.C.	No Connection. Not internally connected.
10	ENOUT	On/Off Signal Open-Drain Output. Typically used to turn on/off a POL power supply under the PMBus command or A3/ONOFF control. See the <i>ENOUT Operation</i> and <i>MFR_MODE (D1h)</i> sections.
11	$\overline{\text{FLT}}$	Fault Output, Active-Low Open-Drain Output. Typically connected to system controller/master interrupt input.
12	A3/ONOFF	Dual-Functioned Three-State MAX8688 Slave Address Identifier (MSB) and POL On/Off Control using the MFR_MODE Command. See the <i>MAX8688 Address Assignment</i> and <i>A3/ONOFF Operation</i> sections.
13	A2/SDAE	Dual-Functioned Three-State MAX8688 Slave Address Identifier and EEPROM I <sup>2</sup> C Data Line. See the <i>MAX8688 Address Assignment</i> and <i>External EEPROM Interface</i> sections.
14	A1/SCLE	Dual-Functioned Three-State MAX8688 Slave Address Identifier (LSB) and EEPROM I <sup>2</sup> C Clock Line. See the <i>MAX8688 Address Assignment</i> and <i>External EEPROM Interface</i> sections.
15	DACOUT	Analog Voltage Output of Internal 12-Bit DAC. Connect DACOUT to REFIN or FB of the DC-DC module with high impedance in shutdown.
16	AGND	Analog Ground. Connect AGND to DGND externally close to the device.
17	AVDD	Analog Power-Supply Input (3.3V, typ). Connect AVDD to DVDD externally. Connect 0.1µF capacitor from AVDD to AGND.
18	REFO	Buffered Reference Output. Connect a 1µF capacitor from REFO to ground.
19	RS_C	Filter Capacitor Connection for V <sub>SENSE</sub> Amplifier
20	RS-	Differential Remote-Sense Input Return of the DC-DC Output Voltage. Connect RS- to the return terminal at the load.
21	RS+	Differential Remote-Sense Input of DC-DC Output Voltage. Connect RS+ to the load terminal where the output must be regulated.
22	ISN-	Differential-Sense Input Return of DC-DC Output Current. Connect ISN- to the negative end of the current-sense resistor (Figure 3). In case of DCR sensing, connect ISN- to the return terminal of filter capacitor C <sub>S</sub> (Figure 7).
23	ISN+	Differential-Sense Input of DC-DC Output Current. Connect ISN+ to the positive end of the current-sense resistor. In case of DCR sensing, connect ISN+ to the junction of filter resistor and capacitor (R <sub>S</sub> and C <sub>S</sub> ) (Figure 7).
24	ISN_C	Filter Capacitor Connection for I <sub>SENSE</sub> Amplifier
—	EP	Exposed Pad. Connect EP to the AGND plane for the POL for best temperature measurement performance. Do not use EP as the main ground connection.

# Digital Power-Supply Controller/Monitor with PMBus Interface

MAX8688

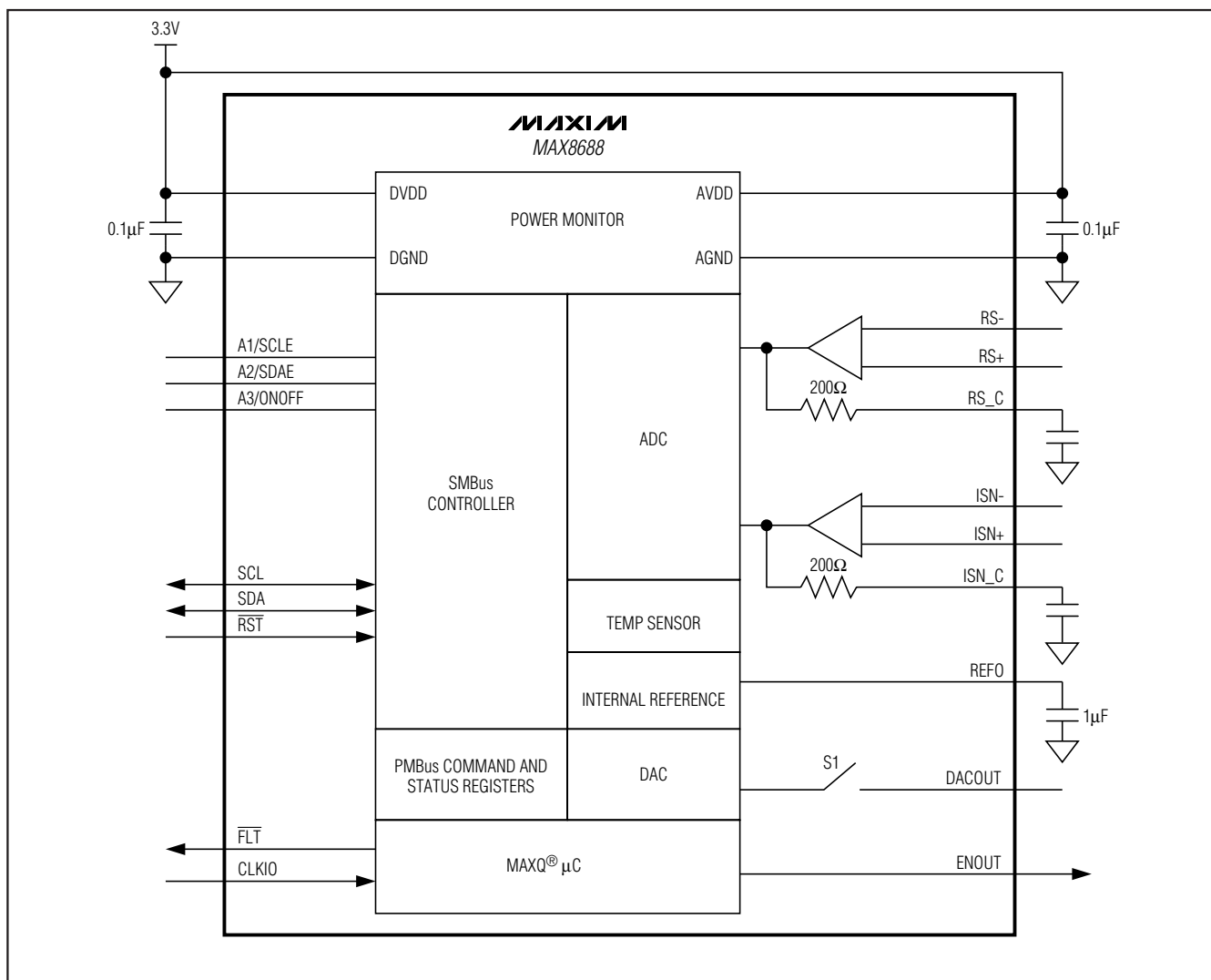

Figure 1. MAX8688 Functional Diagram

## Detailed Description

For many applications, it is desirable to control the output voltage of a POL power supply to a much higher accuracy than the offered standard 1% overtemperature specification. Many designs are required to access information such as output voltage, output current, and temperature of individual power supplies in a board, for monitoring system health as well as logging fault information to help in failure analysis. Moreover, it is desirable to sequence startup and shutdown of multiple power supplies in an application with programmable start, stop delays, and soft-start ramp rates to avoid

latchup and stressing of ESD structures. The MAX8688 solves these problems by providing the required functions in a small compact IC that is capable of interfacing with a master controller through an on-board PMBus interface. Up to 127 MAX8688s can reside on the same PMBus bus, each controlling its own POL, under command from the system controller, as shown in Figure 2. Long traces from POLs located at various system board locations for voltage sensing and current sensing are avoided resulting in a cleaner layout for the system designer. POLs can therefore be placed close to the load where they provide the best transient response with short power plane runs.

MAXQ is a registered trademark of Maxim Integrated Products, Inc.

# Digital Power-Supply Controller/Monitor with PMBus Interface

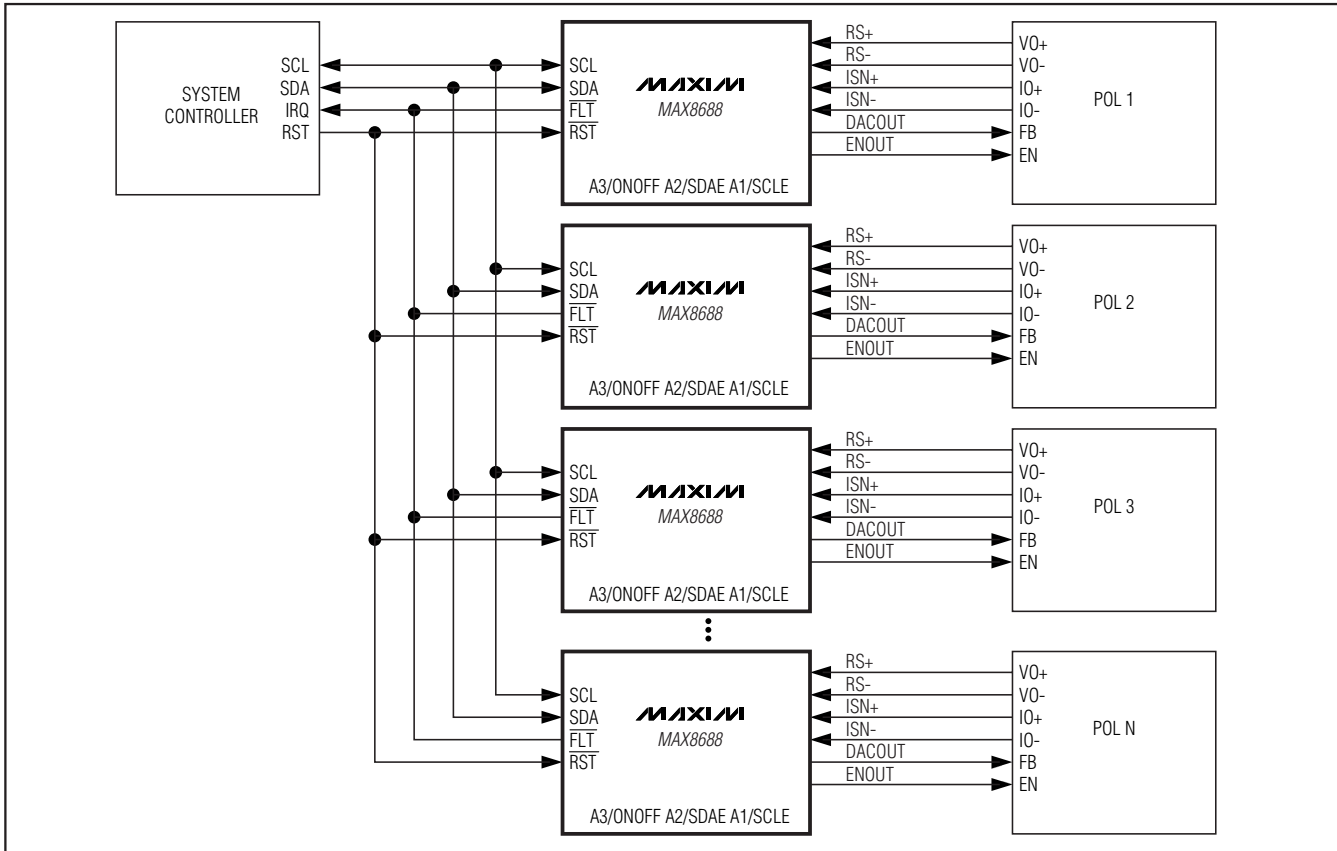

Figure 2. System Application Showing Multiple MAX8688s Controlling POL Power Supplies

## MAX8688 Operating Modes

### Reference Input (REFIN) Mode

Figure 3 shows the typical manner in which the MAX8688 is used in an application where the POL has a reference input, REFIN, to which it regulates its output voltage between the VO+ and VO- terminals. In the REFIN application, the DACOUT of the MAX8688 is connected to the REFIN input of the POL. The output voltage of the POL is sensed using RS+ and RS-. The sensed voltage is suitably filtered by an internal 200Ω resistor and external capacitor connected to RS\_C and is multiplexed to a 12-bit ADC that uses an accurate internal reference voltage. On receipt of either an OPERATION ON command or a turn-on signal from A3/ONOFF, the MAX8688 commences the startup operation that has been programmed for the POL being controlled.

After the programmed  $t_{ON\_DELAY}$  time, the MAX8688 open-drain ENOUT output goes active and the POL output voltage is ramped up to its target VOUT\_COMMAND value precisely in the programmed  $t_{ON\_RISE}$  time. This facilitates easy implementation of tracking of multiple out-

put rails. On reaching the target output voltage, the MAX8688 continuously monitors the POL output voltage obtained at the RS+ and RS- inputs, and regulates it to within  $\pm 0.2\%$  for line, load, and temperature variations by incrementing or decrementing the DACOUT output 1 LSB (0.5mV) at a time. The MAX8688 output-voltage correction rate is programmable up to 10kHz by the MFR\_VOUT\_CORRECTION\_RATE parameter. Once the requested target POL voltage is reached, it is possible to easily margin up or down the POL voltage at a pre-programmed slew rate set by the parameter VOUT\_TRANSITION\_RATE. To achieve this, the MAX8688 increments or decrements the DACOUT output in a suitable number of steps that depend on the programmed transition rate. In addition, the user needs to program the VOUT\_SCALE\_LOOP parameter equal to any voltage-divider ratio implemented on the POL from its output voltage node to the inverting input of its error amplifier. This allows the MAX8688 to correctly calculate the number of DACOUT steps and voltage increments/decrements per step and thus achieves the programmed rise time and transition time.

# Digital Power-Supply Controller/Monitor with PMBus Interface

Since the reference voltage input is provided by the MAX8688, the REFIN mode provides complete control of the POL in terms of soft-start, soft-stop, and margining transitions. It may be noted that the slew rates during soft-start ( $t_{ON\_RISE}$ ) and during margining ( $V_{OUT\_TRANSITION\_RATE}$ ) should be programmed with POL current-limit consideration. An excessively fast slew rate causes the POL to trip due to overcurrent. A general guideline for setting the output-voltage slew rate is as follows:

$$SLEW\ RATE \leq \frac{(I_{LIMIT} - I_{LOAD})}{C_{OUT}}$$

where  $C_{OUT}$  is the output capacitance on the POL output,  $I_{LOAD}$  is the load current being delivered by the POL, and  $I_{LIMIT}$  is the current-limit setting of the POL. On receipt of either an OPERATION OFF command or a turn-off signal from A3/ONOFF, the MAX8688 commences the shutdown operation that has been programmed for the POL being controlled. After the programmed  $t_{OFF\_DELAY}$  time, the MAX8688 ramps down the output voltage to zero precisely in the programmed  $t_{OFF\_FALL}$  time, and deasserts its open-drain ENOUT output.

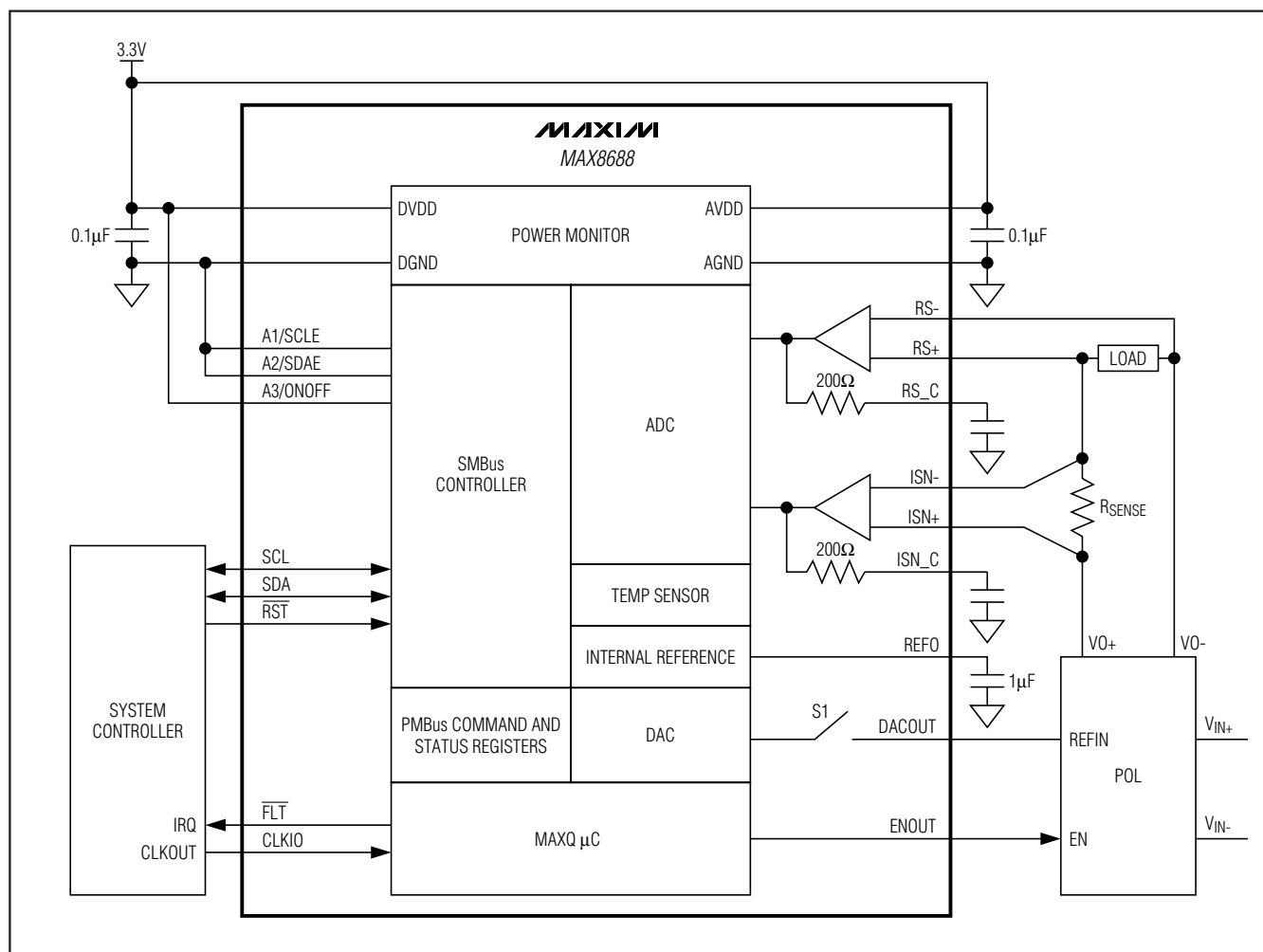

Figure 3. Typical System Application—REFIN Mode

# Digital Power-Supply Controller/Monitor with PMBus Interface

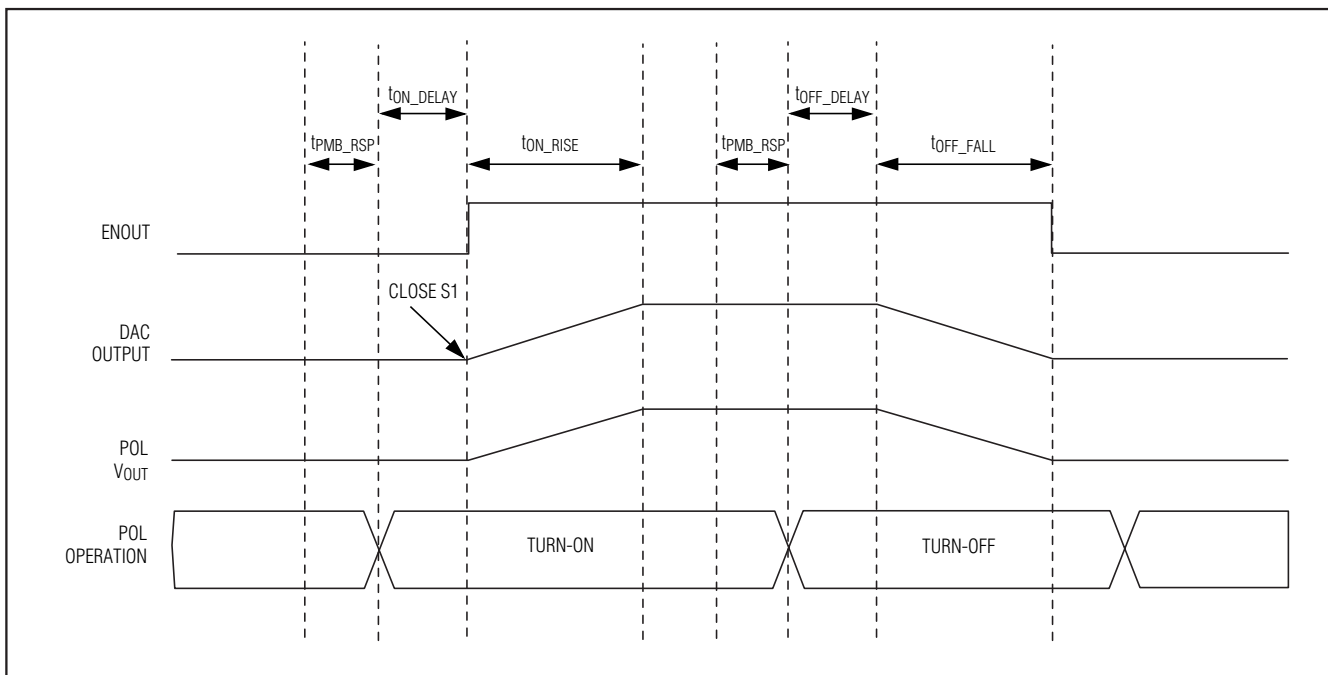

Figure 4. REFIN Mode Timing

### Feedback (FB) Mode

In applications where a REFIN input is not available, the MAX8688 interfaces to the inverting input of the POL error amplifier, the feedback node (FB), through a resistor  $R_{FB}$  as shown in Figure 5. In steady-state operation, the MAX8688 controls the POL voltage as measured between RS+ and RS- to 0.2% accuracy over line, load, and temperature variations, by adjusting DACOUT 1 LSB (0.5mV) at a time, up and down as required. This mode of operation is termed FB mode. Since the MAX8688 does not have control over the POL error-amplifier reference voltage, this mode relies on the POL soft-start setting to implement the required soft-start time. On receipt of either an OPERATION ON command or a turn-on signal from A3/ONOFF, the MAX8688 commences startup operations that have been programmed for the POL being controlled. After the programmed  $t_{ON\_DELAY}$  time, the MAX8688 open-drain ENOUT output goes active, causing the POL to ramp up its output voltage to its target value. The soft-start time taken by the POL to ramp from zero to its commanded output voltage should be entered into the MAX8688 with the  $t_{ON\_RISE}$  parameter.

During  $t_{ON\_RISE}$ , the MAX8688 maintains DACOUT in a high-impedance state by keeping the S1 switch open. This allows the voltage at DACOUT to equal that of the FB node of the POL. At the end of the  $t_{ON\_RISE}$  delay

time, the internal DAC output is initialized to the external voltage measured on DACOUT and switch S1 is closed. If the POL has completed its soft-start and settled down at its output voltage, the DAC output is initialized to the steady-state value of the POL FB voltage. Therefore, when switch S1 is closed, the voltages on either side of the resistor  $R_{FB}$  are equal. Under these conditions, zero current flows into the FB node from DACOUT and no perturbations are introduced to the output voltage. From this point on, the MAX8688 adjusts the voltage at DACOUT to provide accurate output voltage control. In FB mode, the user is required to supply  $t_{ON\_DELAY}$  and  $t_{ON\_RISE}$  parameters. If those parameters are not set (the default values are zero), S1 closes prematurely and cause an initial error in the voltage monitor.

On receipt of either an OPERATION OFF command or a turn-off signal from A3/ONOFF, the MAX8688 commences the shutdown operation that has been programmed for the POL being controlled. After the programmed  $t_{OFF\_DELAY}$  time, the MAX8688 deasserts its open-drain ENOUT output, and turns off the POL.

For the FB mode, the value of  $R_{FB}$  is selected based on following formula:

$$R_{FB} = R_1 \times \frac{\Delta V_{DAC}}{\Delta V_O}$$

# Digital Power-Supply Controller/Monitor with PMBus Interface

where  $R_1$  is the upper feedback divider resistor,  $\Delta V_O$  is the required change in output voltage, and  $\Delta V_{DAC}$  is the DACOUT output voltage change that the user allows. The recommended operating range for the DACOUT voltage for POL output voltage adjustment is between 30mV and 2V. It should be noted that  $\Delta V_{DAC}$  is the difference between the steady-state POL FB node voltage,  $V_{FB}$ , and the voltage limits on DACOUT. This is best illustrated with an example as follows:

Consider an application involving a POL with  $V_{FB} = 0.6V$ . Let the desired margining be  $\pm 10\%$  for a POL output voltage of 1V. For a POL with an upper voltage-divider resistor  $R_1 = 10k\Omega$ ,  $R_{FB}$  is calculated as follows:

$$R_{FB} = 10k\Omega \times \frac{(0.6V - 0.03V)}{0.1V} = 57k\Omega$$

This value of  $R_{FB}$  allows the MAX8688 to margin the POL output voltage up by 10%. It is useful to check the margin low condition by using the formula:

$$\Delta V_O = R_1 \times \frac{\Delta V_{DAC}}{R_{FB}} = 10k\Omega \times \frac{(2.0V - 0.6V)}{57k\Omega} = 0.245V$$

The effective margining range for the 57k $\Omega$  resistor therefore turns out to be between +10% and -24.5%.

It should be noted that the  $V_{OUT\_TRANSITION\_RATE}$  parameter has no effect on FB mode. The transition time for margining in the FB mode of operation is a function of the  $MFR\_V_{OUT\_CORRECTION\_RATE}$  parameter,  $R_{FB}$  and  $R_1$ , and is given by the following formula:

$$t_{FB} = \frac{R_{FB}}{R_1} \times \frac{\Delta V_{OUT}}{MFR\_V_{OUT\_CORRECTION\_RATE}}$$

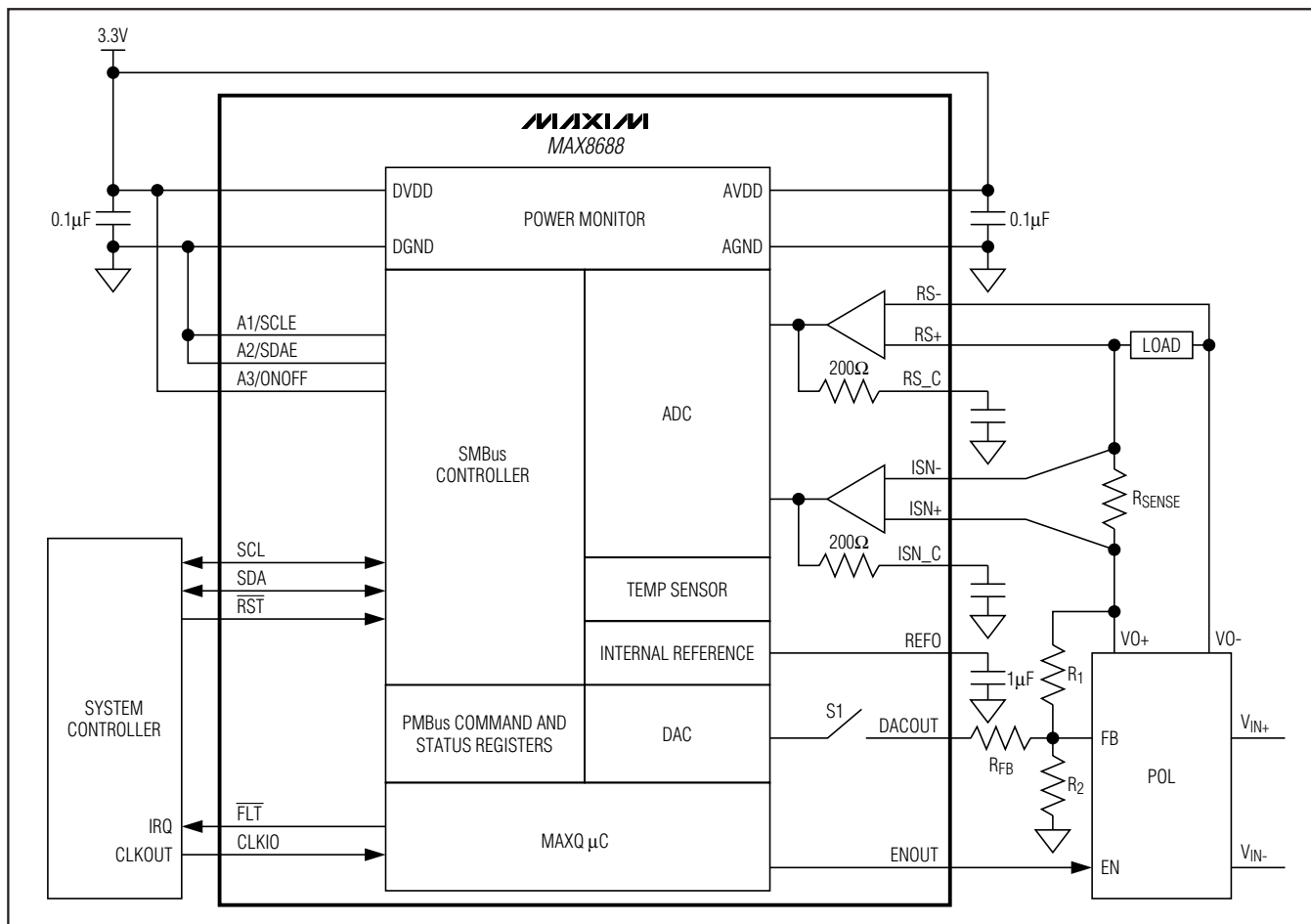

Figure 5. Typical System Application—Feedback Mode

# Digital Power-Supply Controller/Monitor with PMBus Interface

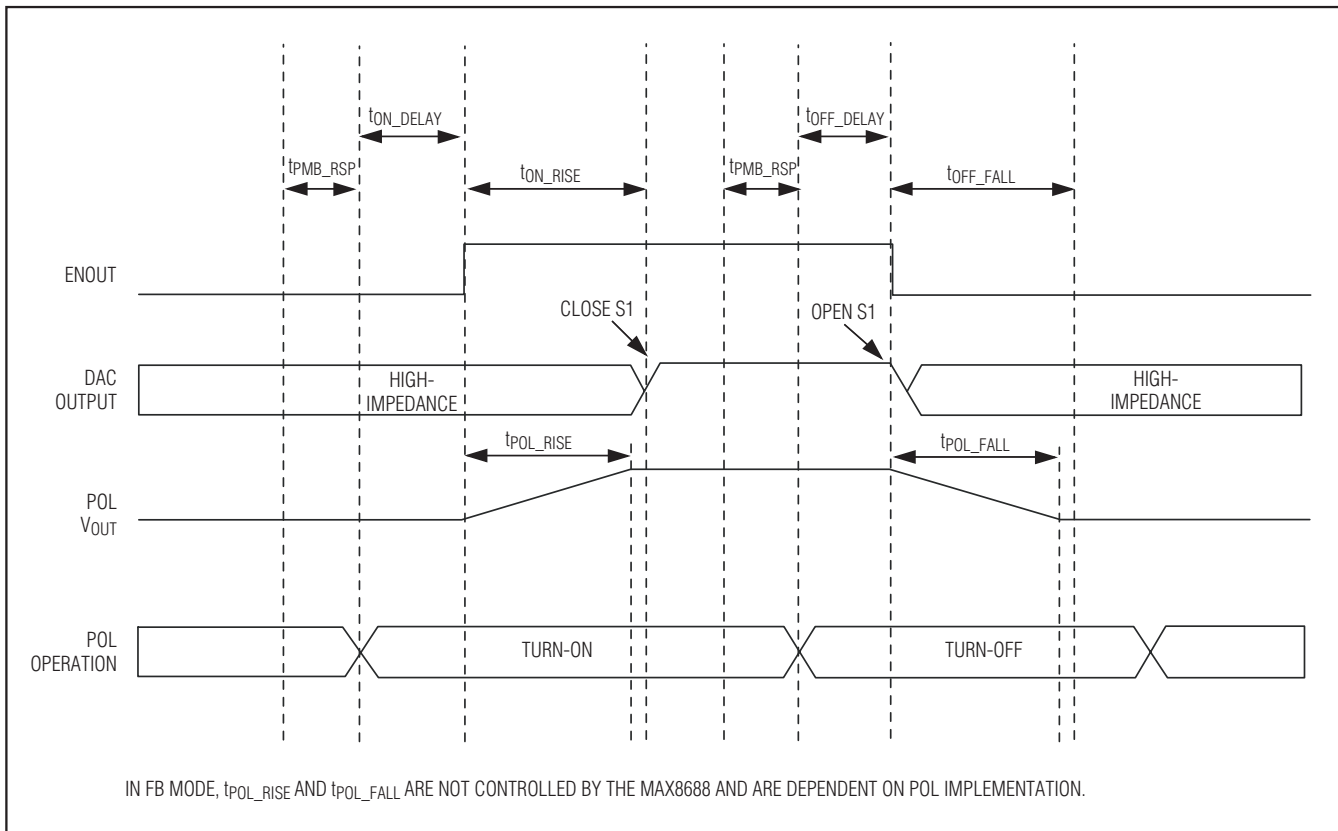

Figure 6. Feedback Mode Timing

## Current Sensing

ISN+ and ISN- are the inputs of the MAX8688 current-sense amplifier. These pins may be connected to a current-sense element such as a current-sense resistor, as shown in Figures 3 and 5. The voltage proportional to the sensed current is suitably filtered by an internal  $200\Omega$  resistor and external capacitor connected to ISN\_C and is multiplexed to a 12-bit ADC that uses an accurate internal reference voltage. A scale factor can be programmed with an IOUT\_SCALE PMBus command to translate the sensed voltage information to the current. The MAX8688 accommodates a current-sense range of +40mV/-10mV across the ISN+ and ISN- inputs. The common-mode voltage range for the current-sense signal can be between 0 and 5.5V. When a

negative current is sensed by the MAX8688,  $\overline{FLT}$  is asserted indicating a negative fault current flow into the POL output.

The DC resistance of the output inductor (DCR) in a switch-mode power supply can also function as a current-sense element, as shown in Figure 7. The RC filter formed by  $R_S$  and  $C_S$  is designed with a time constant of about 10 times larger than the  $L_o/DCR$  time constant. Under these conditions, the DC voltage across  $C_S$  is equal to the product of the average current flowing through the output inductor, essentially the output load current and the DCR. The resistor  $R_{BIAS}$  equal to  $R_S$  is placed in the current-sensing path as shown, to cancel the effect of the input bias current voltage drop across  $R_S$ .

# Digital Power-Supply Controller/Monitor with PMBus Interface

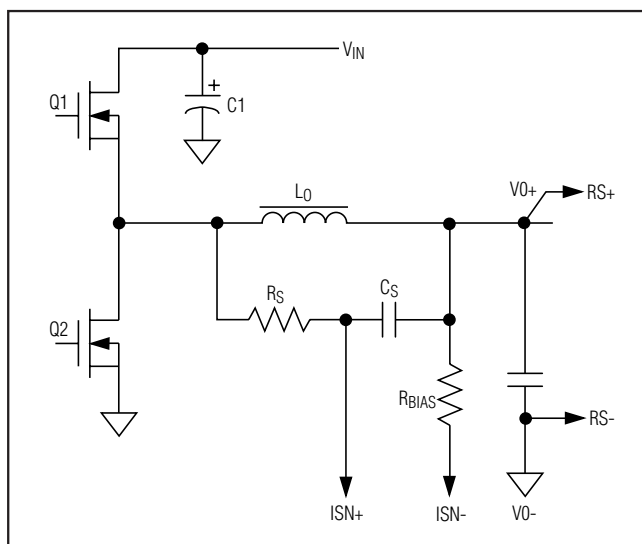

Figure 7. DCR Sensing

## Temperature Sensing

It is intended that the MAX8688 be placed in close proximity to the POL. An on-chip temperature sensor on the MAX8688 senses the temperature of the die, which is related to the exposed pad temperature of the MAX8688 by the junction-to-case thermal resistance. The exposed pad of the MAX8688 can be connected to the heat dissipating ground plane of the POL, and the POL board may be characterized to obtain the relationship between the POL temperature and temperature as measured by the MAX8688. This information may be used to set overtemperature fault settings in the MAX8688.

## External EEPROM Interface

The MAX8688 is capable of communicating with an EEPROM attached to the A1/SCLE and A2/SDAE. The MAX8688 communicates to the EEPROM with an address byte of "1010 0000" for writing and "1010 0001" for reading. For the data values of 2 bytes, the most sig-

nificant byte is stored in the lower offset, whereas the least significant byte is stored in the higher offset.

Upon reset, the MAX8688 tests for the presence of a configuration EEPROM. It searches for the SIGNATURE bytes in the attached EEPROM. If the SIGNATURE bytes are present, it concludes that it has a valid configuration EEPROM and starts reading configuration information from the attached EEPROM. If slave address information is present, this overrides the slave address information previously set by the address A3:A1 pins.

Table 1 shows the contents and offsets of the configuration information expected by the MAX8688. This information is for reference only. It is recommended to use a properly configured, working MAX8688 and to save its state to the EEPROM and limit modifications to as few fields as possible (such as the slave address).

Some 'reserved' fields may contain data other than 0 when the state is saved to the EEPROM. These locations are ignored on restoration from the EEPROM or are frequently recomputed. Some reserved fields need to be set to greater than 0 to guarantee proper operation timing.

Temperature, voltage, and current values are stored in internal representation, which is not identical to the format used by the corresponding PMBus command(s). For details on EEPROM internal representation, see the notes following Table 1.

For example, to store to the EEPROM,  $VOUT\_COMMAND = 3.0V$ ,  $m = 19995$ ,  $b = 0$ ,  $R = -1$ . First calculate the PMBus command value, which is 5998. If the voltage range is 2V, no conversion is required. Hence write 17h to offset 14 and 6Eh to offset 15. If the voltage range is 5.5V, the stored EEPROM value =  $5998/2.75 = 2181$ . So at offset 14, write 08h and offset 15, write 85h.

Note that the conversion is automatically handled by the MAX8688 as it restores and stores configuration information into the EEPROM.

# Digital Power-Supply Controller/Monitor with PMBus Interface

**Table 1. EEPROM Contents**

OFFSET (BYTES)	VALUES (Note 8)	PMBus COMMAND	NOTES
0	MFR_TEMPERATURE_PEAK	D6h	Note 9
2	MFR_VOUT_PEAK	D4h	Note 10
4	MFR_IOUT_PEAK	D5h	Note 11
6	MFR_STATUS_WORD (set to 0)	D8h	—
8–13	Reserved (set to 0)	—	—
14	VOUT_COMMAND	21h	Note 10
16	VOUT_SCALE_LOOP	29h	—
18	TON_RISE	61h	—
10	TON_DELAY	60h	—
22	MFR_TICK_RELOAD This value equals to 0FE84h when using the internal clock, else computed as 65535 – MFR_MODE[15:8]	D1h	—
24	VOUT_MARGIN_HIGH	25h	Note 10
26	VOUT_MARGIN_LOW	26h	Note 10
28	MFR_VOUT_CORRECTION_RATE	D2h	—
30	MFR_SAMPLE_RATE	D3h	—
32	VOUT_OV_FAULT_LIMIT	40h	Note 10
34	VOUT_OV_WARN_LIMIT	42h	Note 10
36	VOUT_UV_FAULT_LIMIT	44h	Note 10
38	VOUT_UV_WARN_LIMIT	43h	Note 10
40	IOUT_OC_FAULT_LIMIT	46h	Note 11
42	IOUT_OC_WARN_LIMIT	4Ah	Note 11
44	OT_FAULT_LIMIT	4Fh	Note 9
46–53	Reserved (set to 0)	—	—
54	MFR_MODE Must match MFR_TICK_RELOAD setting	D1h	—
56	MFR_FAULT_RETRY	DAh	—
58	MFR_FAULT_RESPONSE	D9h	—
60–63	Reserved (set to 1)	—	—
64–71	Reserved (set to 0)	—	—
72	OT_WARN_LIMIT	51h	Note 9
74	IOUT_SCALE	38h	—
76	TOFF_DELAY	64h	—
78	VOUT_TRANSITION_RATE	27h	—
80	Reserved (set to 0)	—	—
82	MFR_FILTER_MODE	D7h	—
84	MFR_SET_ADDRESS Low byte: SMBus slave address, high byte: reserved	DBh	—
86	TOFF_FALL	65h	—
88	MFR_IOUT_TEMP_COEFF	DCh	—
90	Reserved (set to 0)	—	—
92–125	Reserved (set to 0)	—	—
126	SIGNATURE (set to 4453h)	N/A	—

**Note 8:** For a 2-byte value, the most significant byte is written first (lower offset) and then the least significant byte is written last (higher offset).

**Note 9:** To store temperature values to the EEPROM, add 3010 (decimal) to the PMBus value.

**Note 10:** To store voltage values to the EEPROM, no conversion is needed in 2V mode. For 5.5V mode value, divide the PMBus value by 2.75.

**Note 11:** To store current values to the EEPROM, multiply the PMBus value by IOUT\_SCALE and divide by 37.24.

# Digital Power-Supply Controller/Monitor with PMBus Interface

## MAX8688 Operation

Upon reset (power-on reset or applying the device reset pulse to  $\overline{RST}$ ), the MAX8688 goes through an initialization process as shown in Figure 9.

After initialization, the MAX8688 constantly monitors the PMBus and executes the PMBus command accordingly. In addition, if the POL has been commanded to turn on, the MAX8688 also monitors the POL output voltage, current, and temperature at the MFR\_SAMPLE\_RATE. The system controller monitors the POL health by issuing various inquiries and status commands.

Figure 8 shows how the MAX8688 interfaces to an external serial SOT23 EEPROM (such as Atmel AT24C01A) using the A1/SCLE and A2/SDAE in applications where a master controller does not exist or is not required. Using the GUI, the user can select each MAX8688 device and configure all the required output-voltage settings and sequencing/tracking information. Once the configuration is complete, the results can be saved to the external EEPROM by using the STORE\_DEFAULT\_ALL command and configuration restored on the MAX8688 power-on reset. The EEPROM can also be preprogrammed prior to board assembly in the manufacturing environment. A3/ONOFF can be used as a control signal to turn on/off the POL in a similar fashion as the OPERATION command.

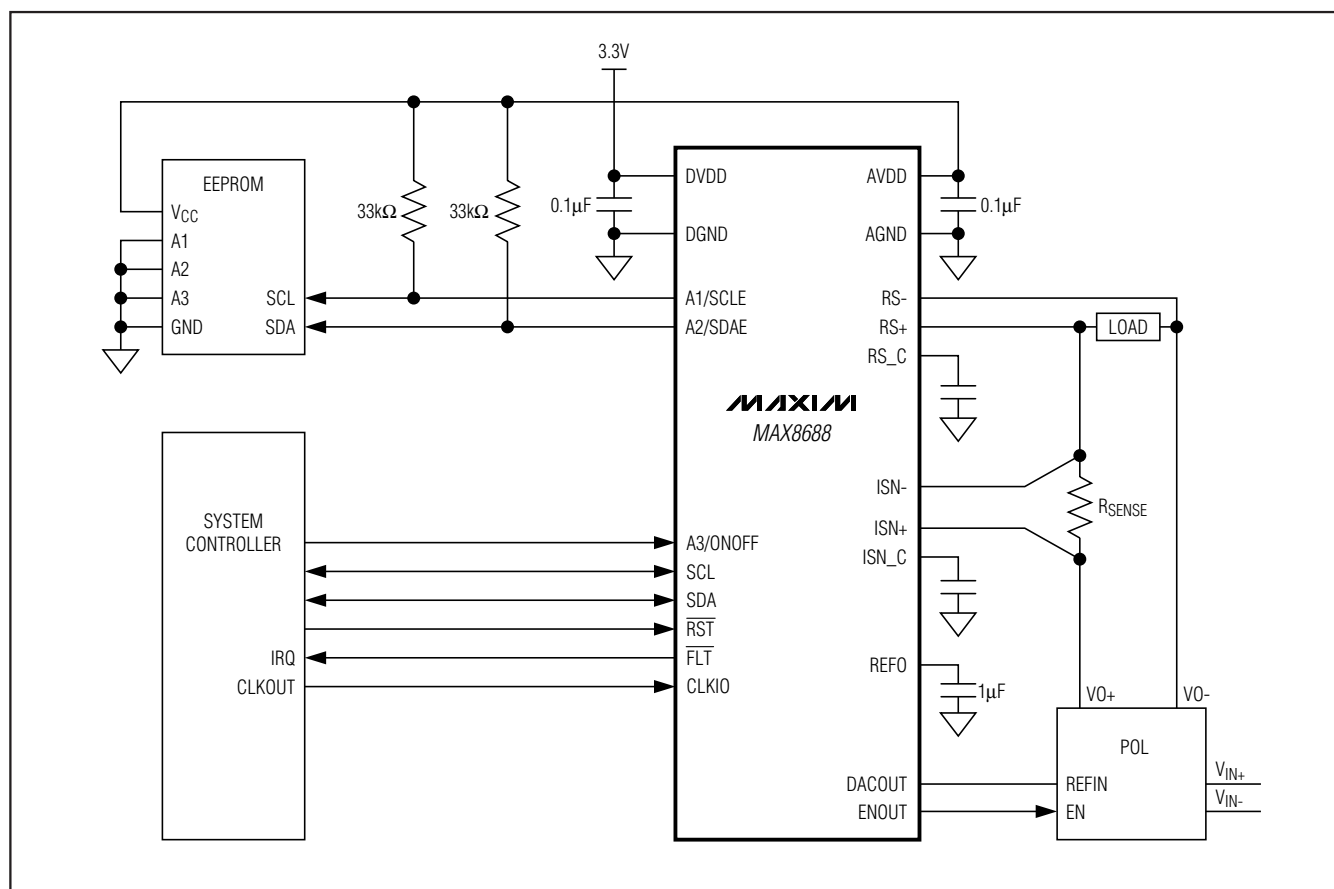

Figure 8. Typical System Application with External EEPROM

# Digital Power-Supply Controller/Monitor with PMBus Interface

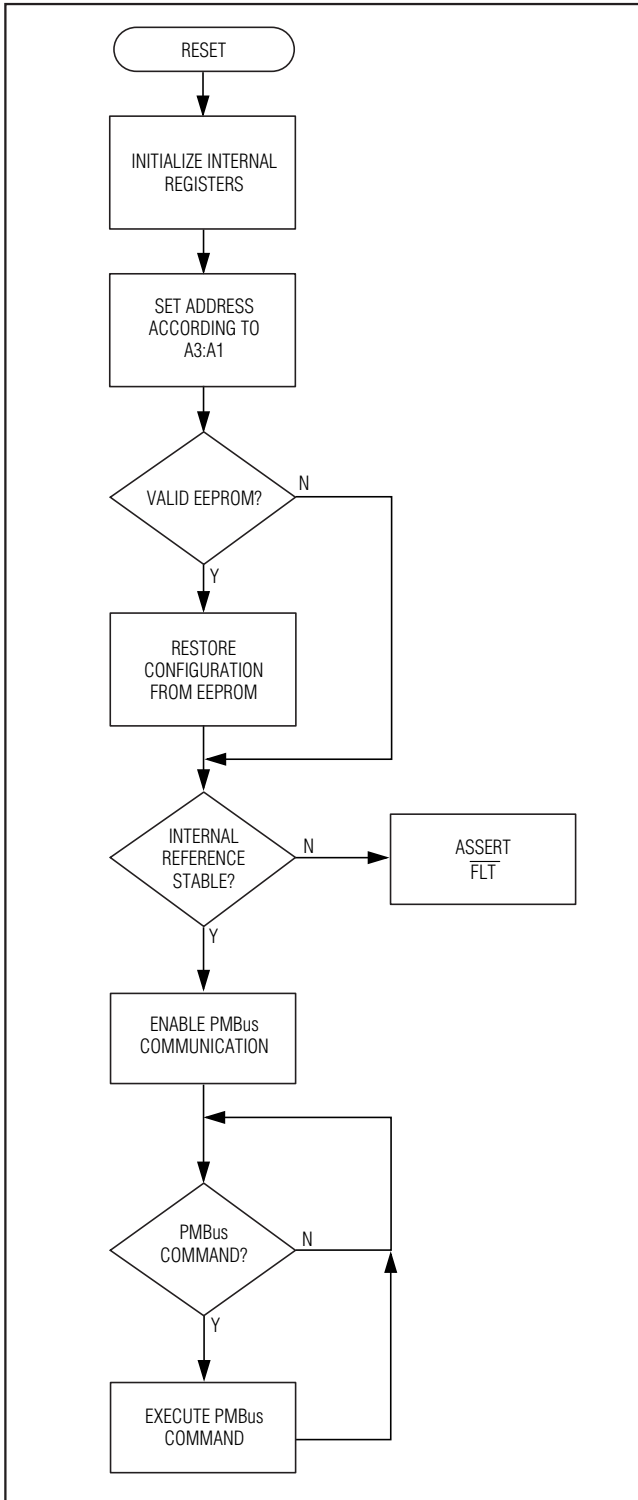

Figure 9. MAX8688 Initialization

## $\overline{RST}$ Operation

The  $\overline{RST}$  signal can be used to reset either the SMBus interface or the MAX8688 depending on the  $\overline{RST}$  pulse width. To reset the SMBus interface, the  $\overline{RST}$  signal is held low for  $t_{SMB\_RST}$ . This resets the SMBus interface, thus flushing any pending PMBus commands or portion of commands received thus far. None of the other MAX8688 internal registers are affected by an SMBus reset. If the host controller applies an active-low pulse to  $\overline{RST}$  for  $t_{RST}$ , the MAX8688 undergoes a device reset and repeats the initialization process.

## ENOUT Operation

To ensure a known and controlled POL power-up state, the MAX8688 is factory-programmed to a specific ENOUT initial power-up state. There are two types of POLs—active-high enable or active-low enable. By default, the MAX8688 assumes that the initial power-up state is the off-state. To operate properly, the POL on-state has to be configured. To configure the ENOUT active state, use the MFR\_MODE command ENOUT Polarity Select.

Table 2. ENOUT Active State

ENOUT DEFAULT STARTUP STATE	ENOUT POLARITY SELECT	ENOUT ACTIVE STATE
0 (Low)	0	Active High
0 (Low)	1	Active Low
1 (High)	0	Active Low
1 (High)	1	Active High

## MAX8688 Address Assignment

The MAX8688 address can be assigned in one of the three ways described below:

- 1) Hardwire by A3:A2:A1.
- 2) Restore from EEPROM.
- 3) By system controller using the MFR\_SET\_ADDRESS command.

Address assignment order is shown in Figure 10.

# Digital Power-Supply Controller/Monitor with PMBus Interface

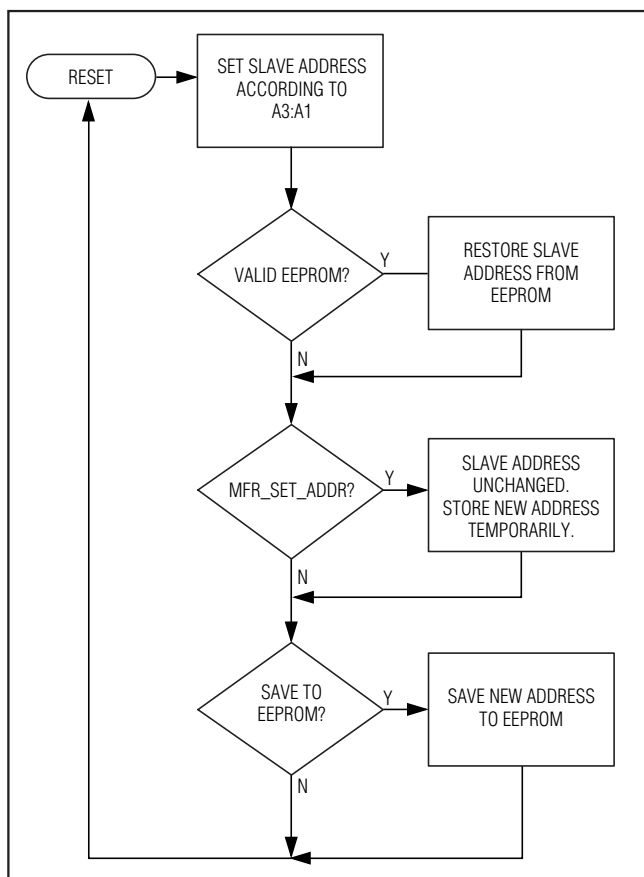

Figure 10. MAX8688 Address Assignment

The MAX8688 reads A3:A2:A1 address pins upon device reset and determines its address according to Table 3.

For example, to configure the MAX8688 to have a slave address of 010 0101 (25h), set A3:A2:A1 = H:L:Z. The MAX8688 also responds to the broadcast address (00h). While it is possible to configure the address pins such that the resulting address is 00h, the MAX8688 with such address is then only responsive to the broadcast address. This may cause undesired results if other PMBus devices are also present on the same bus. Therefore, the hardwire address pins option give  $3^3 - 1 = 26$  address options.

If an EEPROM with valid SIGNATURE bytes is attached to the MAX8688, the MAX8688 also tries to restore its slave address from the EEPROM. This overrides the address set by the address pins. This gives a total of 127 useful slave addresses (address 00h is normally for broadcast address). If the address bit 7 from the EEPROM is set to 1, this is an invalid address and the

Table 3. MAX8688 A3:A1 Address Assignment

A3/ONOFF	A2/SDAE	A1/SCLE	ADDRESS
L	L	L	00h*
L	L	Z	01h**
L	Z	L	02h
L	Z	Z	03h
Z	L	L	04h
Z	L	Z	05h
Z	Z	L	06h
Z	Z	Z	07h
L	L	H	09h
L	Z	H	0Bh
Z	L	H	0Dh
Z	Z	H	0Fh
L	H	L	12h
L	H	Z	13h
Z	H	L	16h
Z	H	Z	17h
L	H	H	1Bh
Z	H	H	1Fh
H	L	L	24h
H	L	Z	25h
H	Z	L	26h
H	Z	Z	27h
H	L	H	2Dh
H	Z	H	2Fh
H	H	L	36h
H	H	Z	37h
H	H	H	3Fh

\*The address 00h is reserved for broadcast.

\*\*The shaded addresses are not available if an external EEPROM is attached.

MAX8688 continues using the address set by the address pins. When an EEPROM is attached to A2/SDAE and A1/SCLE, these pins assume either a logic-high or logic-low level, therefore, the resulting number of possible addresses set by the A3:A2:A1 pins in this scenario is  $2^3 - 1 = 7$ .

In addition, for the MAX8688 with an EEPROM attached, the system controller can change the MAX8688 slave address by sending the new address with the MFR\_SET\_ADDRESS command. However, the new address is not immediately effective. The new address must be stored to the EEPROM first. Then, a device reset has to be applied to the MAX8688 which undergoes the address assignment procedure and recalls the new address from the EEPROM.

# Digital Power-Supply Controller/Monitor with PMBus Interface

## A3/ONOFF Operation

In addition to providing address information to the MAX8688, A3/ONOFF can also be used as a control signal for turning the POL on or off, similar to the OPERATION command. To use A3/ONOFF to control the POL, configure the A3 Control Enable bit in MFR\_MODE command.

When A3 control is enabled, a transition of A3/ONOFF from low to high turns the POL on, as if the MAX8688 has received an OPERATION ON command. A transition of A3/ONOFF from high to low initiates a soft-off to the POL—as if the MAX8688 has received an OPERATION OFF command (soft-off, with sequencing). The MAX8688 still responds to the PMBus OPERATION command while A3 control is enabled. To detect the A3/ONOFF input, the A3/ONOFF signal pulse width has to satisfy the  $t_{A3\_LOW}$  and  $t_{A3\_HIGH}$  requirement to be detected. If disabled (cleared to 0), the MAX8688 ignores the

A3/ONOFF state and function as directed by the OPERATION command only.

The dual functionality of A3/ONOFF of the MAX8688 requires the system enable signal to be isolated from A3/ONOFF until the address setting has been read and latched by the MAX8688. Figure 11 shows one implementation for the three possible states of the A3/ONOFF setting. In each case, the system enable signal (MAX8688\_EN) is applied to the input of a three-state buffer whose output is kept in the high-impedance state by a control input signal (HIZ\_EN) for a time period during which the MAX8688 reads and latches the A3/ONOFF address setting. After this period, the control signal HIZ\_EN goes low and allows the system enable signal to be applied to the MAX8688 A3/ONOFF pin. After a  $t_{A3\_LOW}$ , the MAX8688\_EN signal transitions from low to high and causes the MAX8688s to commence POL startup operations.

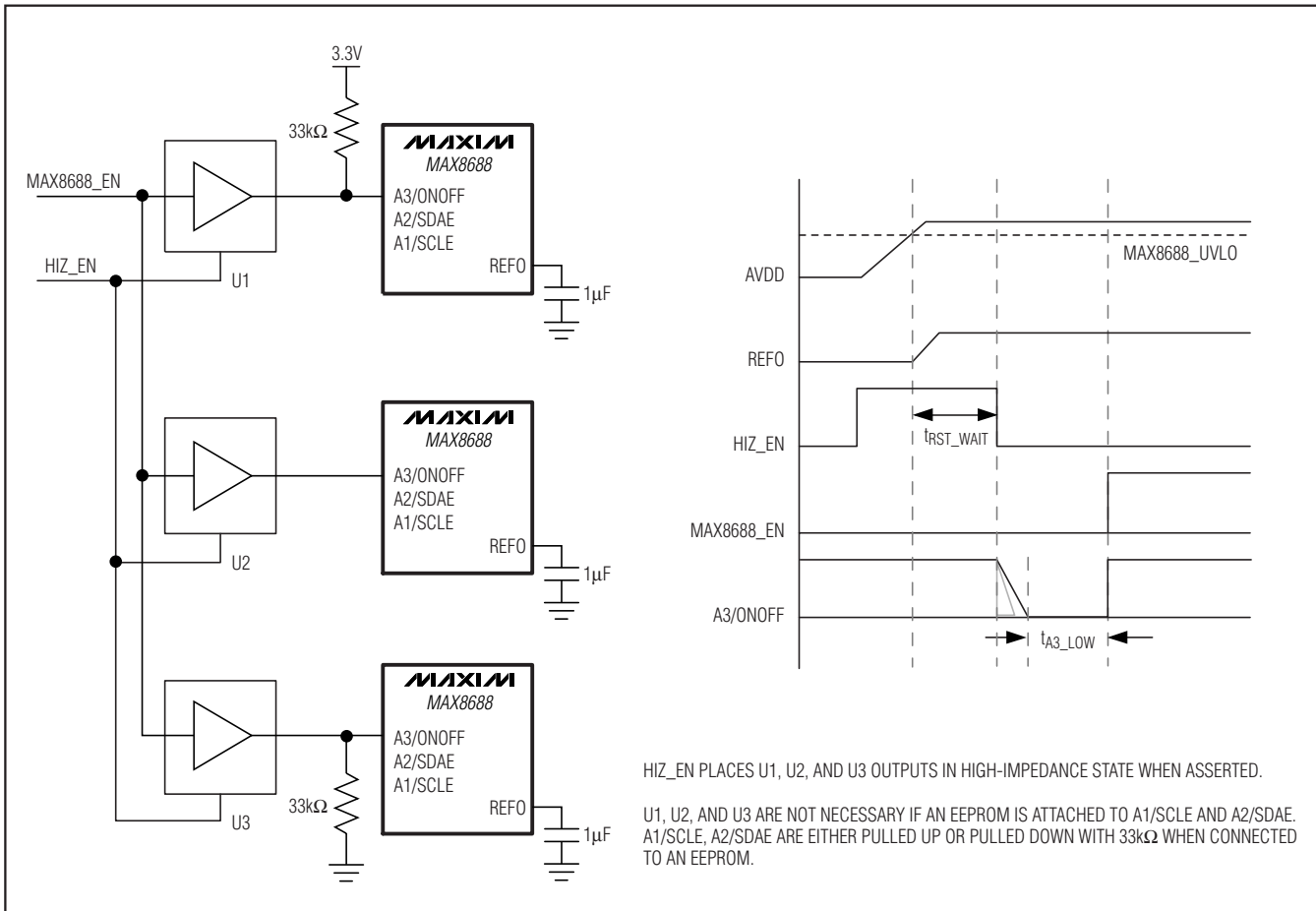

Figure 11. Application Diagram with A3/ONOFF as Both Address and On/Off Control Signal

# Digital Power-Supply Controller/Monitor with PMBus Interface

MAX8688

## PMBus Digital Interface

From a software perspective, the MAX8688 appears as a PMBus device capable of executing a subset of PMBus commands. A PMBus 1.0-compliant device uses the SMBus version 1.1 for transport protocol and responds to the SMBus slave address. In this data sheet, the term SMBus is used to refer to the electrical characteristics of the PMBus communication using the SMBus physical layer. The term PMBus is used to refer to the PMBus command protocol.

The MAX8688 employs five standard SMBus protocols (Write Word, Read Word, Write Byte, Read Byte and Send Byte (see Figures 12–15)) to program output voltage and warning/faults thresholds, read monitored data, and provide access to all manufacturer-specific commands.

The MAX8688 also supports the group command. The group command is used to send commands to more than one PMBus device. It is not required that all the devices receive the same command. However, no more than one command can be sent to any one device in one group command packet. The group command must not be used with commands that require receiving devices to respond with data, such as the STATUS\_BYTE command. When the MAX8688 receives a command through this protocol, it immediately begins execution of the received command after detecting the STOP condition.

When the data word is transmitted, the lower order byte is sent first and the higher order byte is sent last. Within any byte, the most significant bit (MSB) is sent first and the least significant bit (LSB) is sent last.

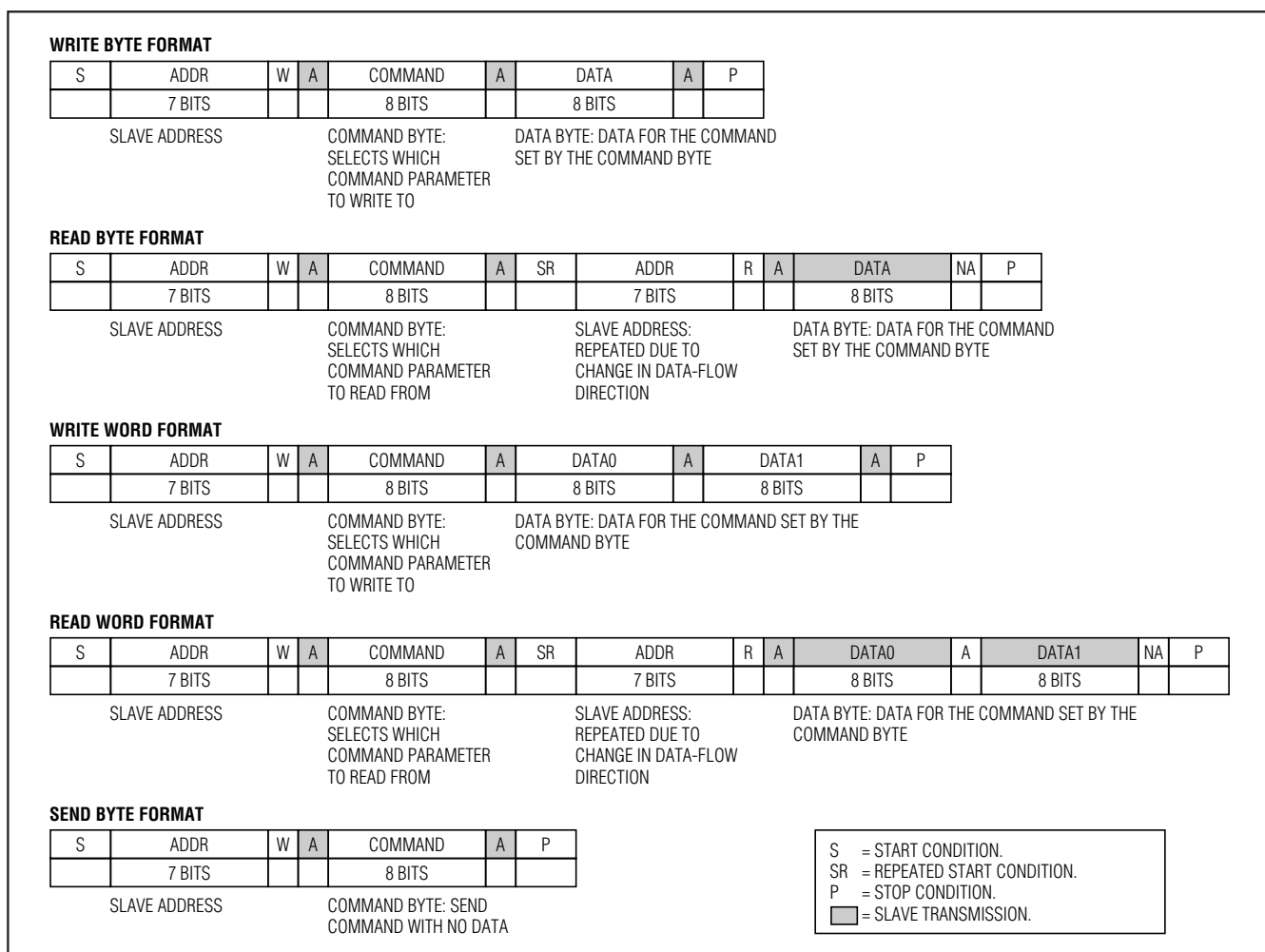

Figure 12. SMBus Protocols

# Digital Power-Supply Controller/Monitor with PMBus Interface

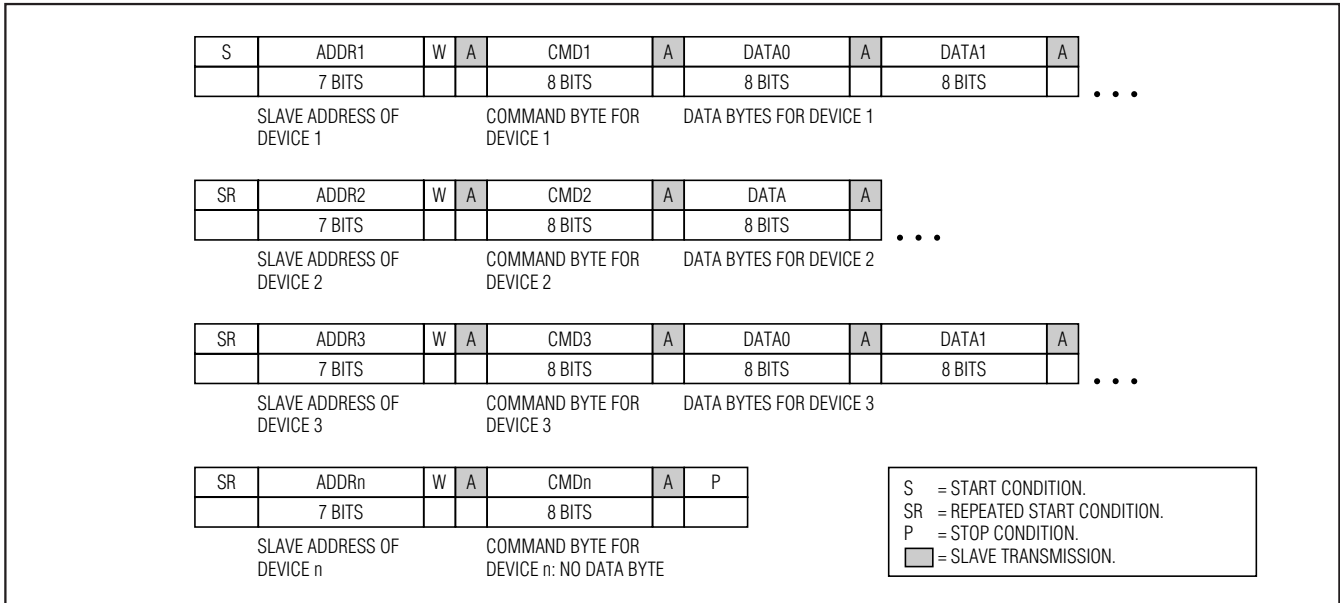

Figure 13. SMBus Group Command Protocol

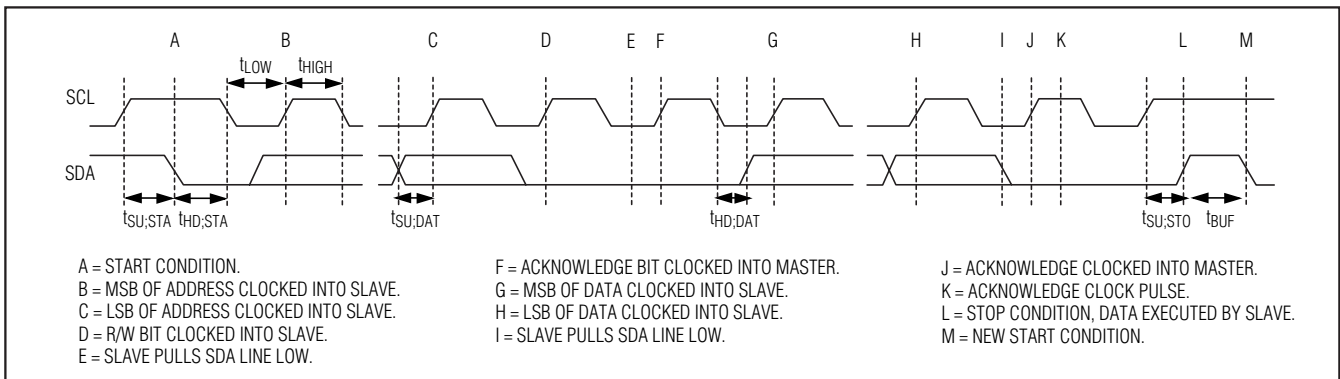

Figure 14. SMBus Write Timing Diagram

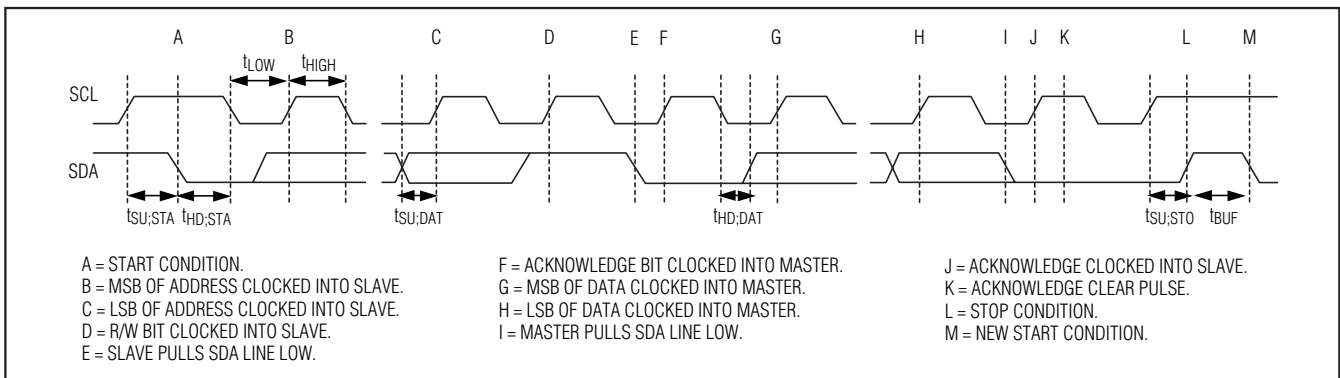

Figure 15. SMBus Read Timing Diagram

# Digital Power-Supply Controller/Monitor with PMBus Interface

The MAX8688 SMBus interface does not support packet error checking (PEC). It does not support the 35ms timeout either. Therefore, to reset the MAX8688 SMBus interface, the host controller has to hold RST low for tSMB\_RST. This resets the SMBus interface. See the *RST Operation* section.

## PMBus Protocol Support

The MAX8688 supports a subset of the commands defined in the Power System Management Protocol Specification Part II - Command Language Revision 1.0. For detailed specifications and the complete list of PMBus commands, refer to Part II of the PMBus specification available at [www.PMBus.org](http://www.PMBus.org). The supported PMBus commands and the corresponding MAX8688 behavior are described in this document.

All data values are represented in DIRECT format, unless otherwise stated. Whenever the resolution of the data is less than the number of bits required, data are right justified (only the lower bits are significant) and the higher order bits are zero-padded, unless otherwise

stated. For example, for a 2-byte value where the MAX8688 only has 12-bit data to return, the MAX8688 returns data in the lower 12 bits and zero-padded the upper 4 bits. Whenever the PMBus specification refers to the “PMBus device,” it is referring to MAX8688 operating in conjunction with a POL device. While the command may call for turning on or off the PMBus device, the MAX8688 always remains on to continue communicating with the PMBus master and the MAX8688 transfers the command to the POL device accordingly.

## Data Format

Voltage data for commanding or reading the output voltage or related parameters (such as the overvoltage threshold) are presented in DIRECT format. DIRECT format data is a 2-byte, two’s complement binary value. DIRECT format data may be used with any command that sends or reads a parametric value. The DIRECT format uses an equation and defined coefficients to calculate the desired values. The coefficients used by the MAX8688 can be found in Table 4.

**Table 4. MAX8688 PMBus Command Summary**

	COMMAND CODE	COMMAND NAME	TRANSACTION TYPE	NO. OF BYTES	m	b	R
1	01h	OPERATION	R/W Byte	1	—	—	—
2	03h	CLEAR_FAULTS	Send Byte	0	—	—	—
3	11h	STORE_DEFAULT_ALL	Send Byte	0	—	—	—
4	12h	RESTORE_DEFAULT_ALL	Send Byte	0	—	—	—
5	21h	VOUT_COMMAND	R/W Word	2	19995	0	-1
6	25h	VOUT_MARGIN_HIGH	R/W Word	2	19995	0	-1
7	26h	VOUT_MARGIN_LOW	R/W Word	2	19995	0	-1
8	27h	VOUT_TRANSITION_RATE	R/W Word	2	256	0	0
9	29h	VOUT_SCALE_LOOP	R/W Word	2	128	0	0
10	38h	IOUT_SCALE	R/W Word	2	1	0	1
11	40h	VOUT_OV_FAULT_LIMIT	R/W Word	2	19995	0	-1
12	42h	VOUT_OV_WARN_LIMIT	R/W Word	2	19995	0	-1
13	43h	VOUT_UV_WARN_LIMIT	R/W Word	2	19995	0	-1
14	44h	VOUT_UV_FAULT_LIMIT	R/W Word	2	19995	0	-1
15	46h	IOUT_OC_FAULT_LIMIT	R/W Word	2	23109	0	-2
16	4Ah	IOUT_OC_WARN_LIMIT	R/W Word	2	23109	0	-2
17	4Fh	OT_FAULT_LIMIT	R/W Word	2	-7612	335	-3

# Digital Power-Supply Controller/Monitor with PMBus Interface

Table 4. MAX8688 PMBus Command Summary (continued)

	COMMAND CODE	COMMAND NAME	TRANSACTION TYPE	NO. OF BYTES	m	b	R
18	51h	OT_WARN_LIMIT	R/W Word	2	-7612	335	-3
19	60h	TON_DELAY	R/W Word	2	1	0	1
20	61h	TON_RISE	R/W Word	2	1	0	3
21	64h	TOFF_DELAY	R/W Word	2	1	0	1
22	65h	TOFF_FALL	R/W Word	2	1	0	3
23	78h	STATUS_BYTE	Read Byte	1	—	—	—
24	8Bh	READ_VOUT	Read Word	2	19995	0	-1
25	8Ch	READ_IOUT	Read Word	2	23109	0	-2
26	8Dh	READ_TEMPERATURE_1	Read Word	2	-7612	335	-3
27	98h	PMBUS_REVISION	Read Byte	1	—	—	—
28	99h	MFR_ID	Read Word	2	—	—	—
29	9Ah	MFR_MODEL	Read Word	2	—	—	—
30	9Bh	MFR_REVISION	Read Word	2	—	—	—
31	D0h	MFR_SMB_LOOPBACK	R/W Word	2	—	—	—
32	D1h	MFR_MODE	R/W Word	2	—	—	—
33	D2h	MFR_VOUT_CORRECTION_RATE	R/W Word	2	—	—	—
34	D3h	MFR_SAMPLE_RATE	R/W Word	2	—	—	—
35	D4h	MFR_VOUT_PEAK	R/W Word	2	19995	0	-1
36	D5h	MFR_IOUT_PEAK	R/W Word	2	23109	0	-2
37	D6h	MFR_TEMPERATURE_PEAK	R/W Word	2	7612	335	-3
38	D7h	MFR_FILTER_MODE	R/W Word	2	—	—	—
39	D8h	MFR_FAULT_STATUS	Read Word	2	—	—	—
40	D9h	MFR_FAULT_RESPONSE	R/W Word	2	—	—	—
41	DAh	MFR_FAULT_RETRY	R/W Word	2	—	—	—
42	DBh	MFR_SET_ADDRESS	R/W Word	2	—	—	—
43	DCh	MFR_IOUT_TEMP_COEFF	R/W Word	2	6888	0	-5

The MAX8688 uses DIRECT format for all parameters with the exception of manufacturer-specific commands. Refer to the manufacturer command details on data format.

$$X = \frac{1}{m} (Y \times 10^{-R} - b)$$

### Interpreting Received DIRECT Format Values

The host system uses the following equation to convert the value received from the PMBus device, in this case the MAX8688, into a reading of volts, amperes, degrees Celsius or other units as appropriate:

where X is the calculated, real world value in the appropriate units (A, V, °C, etc.); m, the slope coefficient, is a 2-byte, two's complement integer; Y is a 2-byte two's complement integer received from the PMBus device; b, the offset, is a 2-byte, two's complement integer; and R, the exponent, is a 1-byte, two's complement integer.

# Digital Power-Supply Controller/Monitor with PMBus Interface

## Sending a DIRECT Format Value

To send a value, the host must use the equation below to solve for Y:

$$Y = (mX + b) \times 10^R$$

where:

Y is the 2-byte, two's complement integer to be sent to the unit;

m, the slope coefficient, is the 2-byte, two's complement integer;

X is a real world value, in units such as amperes or volts, to be converted for transmission;

b, the offset, is the 2-byte, two's complement integer; and

R, the exponent, is the decimal value equivalent to the 1-byte, two's complement integer.

The following example demonstrates how the host can send and retrieve values from the MAX8688.

From Table 4, the coefficients used in the following parameters are:

VOUT\_COMMAND:           m = 19995, b = 0, R = -1

READ\_VOUT:               m = 19995, b = 0, R = -1

If a host wants to request the POL to output a voltage of 3.0V, the corresponding VOUT\_COMMAND value is:

$$Y = (mX + b) \times 10^R$$

$$Y = (19995 \times 3.0 + 0) \times 10^{-1} = 5998.5 \text{ (decimal)} \\ = 176\text{Eh (hex)}$$

Conversely, if the host received a value of 176Eh on a READ\_VOUT command, this is equivalent to:

$$X = \frac{1}{m} (Y \times 10^{-R} - b)$$

$$X = \frac{1}{19995} (176\text{Eh} \times 10^{-(-1)} - 0) \\ = 59980/19995 = 2.999750$$

which is within 0.0083% of 3.0V.

Power supplies and power converters generally have no way of knowing how their outputs are connected to ground. Within the power supply, all output voltages are most commonly treated as positive. Accordingly, all output voltages and output voltage-related parameters of PMBus devices are commanded and reported as positive values. It is up to the system to know that a particular output is negative, if that is of interest to the system.

All output voltage-related commands use 2 data bytes.

## Fault Management and Reporting

For reporting faults/warnings to the host on a real-time basis, the MAX8688 asserts the open-drain  $\overline{\text{FLT}}$  pin and sets the appropriate bit in the STATUS\_BYTE and MFR\_FAULT\_STATUS registers, respectively. On recognition of the  $\overline{\text{FLT}}$  assertion, the host or system manager is expected to poll multiple MAX8688s and retrieves fault/warning information. The Manufacturer Fault Status Register, MFR\_FAULT\_STATUS, provides more detailed information on fault/warning. Faults/warnings are cleared when any one of the following conditions occurs:

- A CLEAR\_FAULTS command is received.
- ENOUT is commanded through the OPERATION command or A3/ONOFF to turn off and then turn on.
- A  $\overline{\text{RST}}$  signal is asserted for longer than  $t_{\text{RST}}$  where the MAX8688 is internally reset.
- Bias power to the MAX8688 is removed and then reapplied.

The MAX8688 responds to fault conditions according to the Manufacturer Fault Response command (MFR\_FAULT\_RESPONSE). This command byte determines how the MAX8688 should respond to each particular fault.

In addition, the MAX8688 responds to the following error conditions.

- 1) If the internal reference fails to operate,  $\overline{\text{FLT}}$  is asserted. To clear this fault, the MAX8688 has to go through a device reset.
- 2) The MAX8688 responds to unsupported commands with a NACK.
- 3) When the host sends insufficient data (too few bytes), the MAX8688 sets the CML bit and asserts  $\overline{\text{FLT}}$ .
- 4) When the host sends too much data (too many bytes), the MAX8688 sets the CML bit and asserts  $\overline{\text{FLT}}$ .

When a read request is issued to a write-only command, the read operation is aborted and no warning is issued.

# Digital Power-Supply Controller/Monitor with PMBus Interface

## PMBus Commands

A summary of the PMBus commands supported by the MAX8688 is described in Table 4.

### OPERATION (01h)

The OPERATION command is used to turn the POL on and off in conjunction with ENOUT according to the ENOUT polarity select setup. The OPERATION command is also used to cause the POL to set the output voltage to the upper or lower margin voltages. The POL stays in the commanded operating mode until a subsequent OPERATION command or change in the state of A3/ONOFF (if enabled) instructs the POL to change to another state.

The valid OPERATION command byte values are shown in Table 5.

The OPERATION command controls how the MAX8688 responds when commanded to change the output. When the command byte is 00h, the MAX8688 turns the POL off immediately and ignores any programmed turn-off delay and fall time. When the command byte is set to 40h, the MAX8688 powers down according to the programmed turn-off delay and fall time.

In Table 5, Act On Fault means that if an output overvoltage warning or output overvoltage fault is detected when the output is margined high, the MAX8688 treats this as a warning or fault and responds as programmed by the warning limit or fault response command. Similarly, if an output undervoltage warning or output undervoltage fault is detected when the output is margined low, the MAX8688 treats this as a qualified warning/fault event and responds as programmed by the warning/fault limit or fault response command.

Any command value not shown in Table 5 is an invalid command. If a MAX8688 receives a data byte that is not listed in Table 5, then it may treat this as invalid data,

**Table 5. OPERATION Command Byte**

COMMAND BYTE	POL ON OR OFF	MARGIN STATE
00h	Immediate off (no sequencing)	—
40h	Soft-off (with sequencing)	—
80h	On	Margin off (Nominal)
98h	On	Margin low (Act On Fault)
A8h	On	Margin high (Act On Fault)

declare a communications fault (set CML bit and assert  $\overline{\text{FLT}}$ ), and respond as described in the *Fault Management and Reporting* section.

The default OPERATION value is 00h.

### CLEAR\_FAULTS (03h)

The CLEAR\_FAULTS command is used to clear any fault bits that have been set. This command clears all bits in the STATUS\_BYTE and MFR\_FAULT\_STATUS registers simultaneously. It also deasserts  $\overline{\text{FLT}}$ .

The CLEAR\_FAULTS command does not cause a POL that has latched off for a fault condition to restart. The status of ENOUT under fault conditions is not affected by this command and should change only if commanded through the OPERATION command or A3/ONOFF.

If the fault is still present after the CLEAR\_FAULTS command is executed, the fault bit shall be set again and the host notified by the usual means.

This command is write-only. There is no data byte for this command.

### STORE\_DEFAULT\_ALL (11h)

The STORE\_DEFAULT\_ALL command instructs the MAX8688 to store configuration information to an external I<sup>2</sup>C EEPROM device attached to A1/SCLE and A2/SDAE. If an error occurs during storing,  $\overline{\text{FLT}}$  asserts and the CML bit is set to 1.

It is permitted to use the STORE\_DEFAULT\_ALL command while the POL is operating. However, the MAX8688 is unresponsive to PMBus commands while storing the configuration. ENOUT maintains its state.

This command is write-only. There is no data byte for this command.

For information on EEPROM contents, see the *External EEPROM Interface* section.

### RESTORE\_DEFAULT\_ALL (12h)

The RESTORE\_DEFAULT\_ALL command instructs the MAX8688 to restore configuration information from an external I<sup>2</sup>C EEPROM device attached to A1/SCLE and A2/SDAE. The RESTORE\_DEFAULT\_ALL command can only be executed when the POL is off. Otherwise, a communication fault occurs (CML = 1) and  $\overline{\text{FLT}}$  asserts. If an error occurs during restoration,  $\overline{\text{FLT}}$  asserts and the CML bit is set to 1.

The STATUS\_BYTE and MFR\_FAULT\_STATUS values are not restored by the RESTORE\_DEFAULT\_ALL command.

This command is write-only. There is no data byte for this command.

For information on EEPROM contents, see the *External EEPROM Interface* section.

# Digital Power-Supply Controller/Monitor with PMBus Interface

## VOUT\_COMMAND (21h)

The VOUT\_COMMAND command loads the MAX8688 with the voltage to which the POL output is to be changed when it is commanded to turn on using the OPERATION command or A3/ONOFF transition when enabled. Once the POL is turned on, changing the VOUT\_COMMAND has no effect on the POL output voltage. The MAX8688 only adjusts the POL to the new VOUT\_COMMAND voltage after receiving a new turn-on command.

The 2 data bytes are in DIRECT format. Valid values are from 0 to 2.048V when the input range is 2.048V and 0 to 5.5V when the input range is 5.5V.

The default VOUT\_COMMAND value is 00h.

## VOUT\_MARGIN\_HIGH (25h)

The VOUT\_MARGIN\_HIGH command loads the MAX8688 with the voltage to which the POL output is to be changed when the OPERATION command is set to margin high. If the POL is already operating at margin high, changing VOUT\_MARGIN\_HIGH has no effect on the output voltage. The MAX8688 only adjusts the POL to the new VOUT\_MARGIN\_HIGH voltage after receiving a new margin high OPERATION command.

The 2 data bytes are in DIRECT format. Valid values are the same as VOUT\_COMMAND.

The default VOUT\_MARGIN\_HIGH value is 00h.

## VOUT\_MARGIN\_LOW (26h)

The VOUT\_MARGIN\_LOW command loads the MAX8688 with the voltage to which the POL output is to be changed when the OPERATION command is set to margin low. If the POL is already operating at margin low, changing VOUT\_MARGIN\_LOW has no effect on the output voltage. The MAX8688 only adjusts the POL to the new VOUT\_MARGIN\_LOW voltage after receiving a new margin low OPERATION command.

The 2 data bytes are in DIRECT format. Valid values are the same as VOUT\_COMMAND.

The default VOUT\_MARGIN\_LOW value is 00h.

## VOUT\_TRANSITION\_RATE (27h)

The VOUT\_TRANSITION\_RATE command sets the rate in mV/μs at which the POL output voltage should change when the POL is commanded to change between the margin high, margin low, and margin off (ON) OPERATION mode. This commanded rate of change does not apply when the POL is commanded to turn on or turn off. In that case, tON\_RISE and tOFF\_FALL applies.

The 2 data bytes are in DIRECT format. Valid values are from 0 to 128mV/μs.

The default VOUT\_TRANSITION\_RATE value is 0mV/μs.

When VOUT\_TRANSITION\_RATE is cleared to 0, VOUT\_TRANSITION\_RATE is ignored and the voltage output is not changed even when commanded by the OPERATION commands. When VOUT\_TRANSITION\_RATE is set to 07FFFh, the voltage output is adjusted as quickly as possible. If a VOUT\_TRANSITION\_RATE parameter results in the DAC outputting an out of range value (valid range 0 to 4090) during transition, the CML flag is set and FLT is asserted to issue a warning.

The VOUT\_TRANSITION\_RATE command applies to REFIN mode only and is ignored in feedback mode.

## VOUT\_SCALE\_LOOP (29h)

In a typical application, the output voltage of a power converter is sensed through a resistive voltage-divider, as illustrated in Figure 16. The resistive voltage-divider reduces or scales the output voltage, VOUT.

The PMBus commands specify the actual POL output voltages and not the input voltage to the control circuit. To allow the MAX8688 to map between the commanded voltage (such as 3.3V) and the voltage at the control circuit input (perhaps 3.3V divided down to match a reference voltage of 2.0V), the VOUT\_SCALE\_LOOP command is used.

$$VOUT\_SCALE\_LOOP = \frac{R2}{R1+R2}$$

The 2 data bytes are in DIRECT format. Valid values are from 0 to 1.0. Note that due to m, b, R representation restriction, the supplied value is rounded off to multiples of 1/128. Therefore, to ensure optimum operation, circuit design should choose a value as close to multiples of 1/128 as possible to avoid rounding errors and thus ensure the final accuracy of VOUT.

This value is dimensionless.

The default VOUT\_SCALE\_LOOP value is 00h.

The VOUT\_SCALE\_LOOP command is ignored in feedback mode.

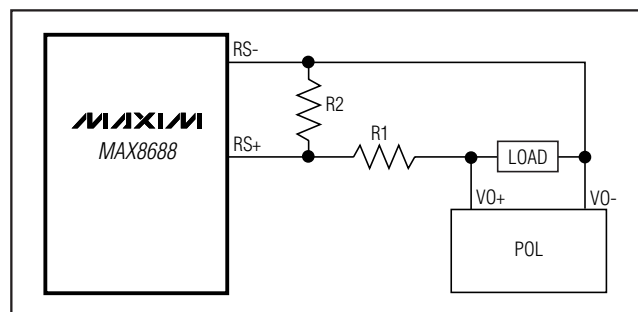

Figure 16. VOUT\_SCALE\_LOOP

# Digital Power-Supply Controller/Monitor with PMBus Interface

## **IOUT\_SCALE (38h)**

The IOUT\_SCALE command is used to set the ratio of the voltage at the current-sense pins to the sensed current. For devices using a fixed current-sense resistor, it is the same value as the resistance.

The unit of the IOUT\_SCALE factor is  $m\Omega$ .

The 2 data bytes are in DIRECT format. Valid values are from  $0.5m\Omega$  to  $5m\Omega$ .

The default IOUT\_SCALE value is  $0m\Omega$ .

## **VOUT\_OV\_FAULT\_LIMIT (40h)**

The VOUT\_OV\_FAULT\_LIMIT command sets the value of the output voltage measured across RS+ and RS- that causes an output overvoltage fault.

The 2 data bytes are in DIRECT format. Valid values are the same as VOUT\_COMMAND.

The default VOUT\_OV\_FAULT\_LIMIT value is 00h.

In response to the VOUT\_OV\_FAULT\_LIMIT being exceeded, the MAX8688:

- 1) Sets the VOUT\_OV bit in the STATUS\_BYTE.
- 2) Sets the VOUT\_OV\_FAULT bit in the MFR\_FAULT\_STATUS register.
- 3) Responds as specified by VOUT\_OV\_FAULT\_RESPONSE bits in the MFR\_FAULT\_RESPONSE register.
- 4) Notifies the host through  $\overline{FLT}$  assertion.

## **VOUT\_OV\_WARN\_LIMIT (42h)**

The VOUT\_OV\_WARN\_LIMIT command sets the value of the output voltage measured across RS+ and RS-, which causes an output-voltage high warning. This value is typically less than the output overvoltage threshold in VOUT\_OV\_FAULT\_LIMIT.

The 2 data bytes are in DIRECT format. Valid values are the same as the VOUT\_COMMAND.

The default VOUT\_OV\_WARN\_LIMIT value is 00h.

In response to the VOUT\_OV\_WARN\_LIMIT being exceeded, the MAX8688:

- 1) Sets the OTHER bit in the STATUS\_BYTE.
- 2) Sets the VOUT\_OV\_WARN bit in the MFR\_FAULT\_STATUS register.
- 3) Notifies the host through  $\overline{FLT}$  assertion.

## **VOUT\_UV\_WARN\_LIMIT (43h)**

The VOUT\_UV\_WARN\_LIMIT command sets the value of the output voltage measured across RS+ and RS-, which causes an output-voltage low warning. This value is typically greater than the output undervoltage fault threshold in VOUT\_UV\_FAULT\_LIMIT.

This warning is masked until the output voltage reaches the programmed voltage at startup and also during turn-off when the POL is disabled.

The 2 data bytes are in DIRECT format. Valid values are the same as VOUT\_COMMAND.

The default VOUT\_UV\_WARN\_LIMIT value is 00h.

In response to violation of the VOUT\_UV\_WARN\_LIMIT, the MAX8688:

- 1) Sets the OTHER bit in the STATUS\_BYTE.
- 2) Sets the VOUT\_UV\_WARN bit in the MFR\_FAULT\_STATUS register.
- 3) Notifies the host using  $\overline{FLT}$  assertion.

## **VOUT\_UV\_FAULT\_LIMIT (44h)**

The VOUT\_UV\_FAULT\_LIMIT command sets the value of the output voltage measured across RS+ and RS-, which causes an output undervoltage fault.

This fault is masked until the output voltage reaches the programmed voltage at startup and also during turn-off when the POL is disabled.

The 2 data bytes are in DIRECT format. Valid values are the same as VOUT\_COMMAND.

The default VOUT\_UV\_FAULT\_LIMIT value is 00h.

In response to violation of the VOUT\_UV\_FAULT\_LIMIT, the MAX8688:

- 1) Sets the OTHER bit in the STATUS\_BYTE.
- 2) Sets the VOUT\_UV\_FAULT bit in the MFR\_FAULT\_STATUS register.
- 3) Responds as specified by VOUT\_UV\_FAULT\_RESPONSE bits in the MFR\_FAULT\_RESPONSE register.
- 4) Notifies the host using  $\overline{FLT}$  assertion.

## **IOUT\_OC\_FAULT\_LIMIT (46h)**

The IOUT\_OC\_FAULT\_LIMIT command sets the value of the output current, in amperes, measured across ISN+ and ISN- that causes the overcurrent detector to indicate an overcurrent fault condition.

The 2 data bytes are in DIRECT format. Valid values are from 0 to  $50/IOUT\_SCALE$  amperes.

The default IOUT\_OC\_FAULT\_LIMIT value is 00h.

In response to the IOUT\_OC\_FAULT\_LIMIT being exceeded, the MAX8688:

- 1) Sets the IOUT\_OC bit in the STATUS\_BYTE.
- 2) Sets the IOUT\_OC\_FAULT bit in the MFR\_FAULT\_STATUS register.

# Digital Power-Supply Controller/Monitor with PMBus Interface

MAX8688

- 3) Responds as specified by IOUT\_OC\_FAULT\_RESPONSE bits in the MFR\_FAULT\_RESPONSE register.
- 4) Notifies the host using  $\overline{\text{FLT}}$  assertion.

## **IOUT\_OC\_WARN\_LIMIT (4Ah)**

The IOUT\_OC\_WARN\_LIMIT command sets the value of the output current, in amperes, measured across ISN+ and ISN- that causes an output overcurrent warning.

The 2 data bytes are in DIRECT format. Valid values are the same as the IOUT\_OC\_FAULT\_LIMIT.

The default IOUT\_OC\_WARN\_LIMIT value is 00h.

In response to the IOUT\_OC\_WARN\_LIMIT being exceeded, the MAX8688:

- 1) Sets the OTHER bit in the STATUS\_BYTE.
- 2) Sets the IOUT\_OC\_WARN bit in the MFR\_FAULT\_STATUS register.
- 3) Notifies the host using  $\overline{\text{FLT}}$  assertion.

## **OT\_FAULT\_LIMIT (4Fh)**

The OT\_FAULT\_LIMIT command sets the temperature, in degrees Celsius, of the on-chip temperature sensor at which an overtemperature fault is detected.

The 2 data bytes are in DIRECT format. Valid values are from -142.5°C to +395.4°C.

The default OT\_FAULT\_LIMIT value is 00h.

In response to the OT\_FAULT\_LIMIT being exceeded, the MAX8688:

- Sets the TEMPERATURE bit in the STATUS\_BYTE.
- Sets the OT\_FAULT bit in the MFR\_FAULT\_STATUS register.
- Responds as specified by OT\_FAULT\_RESPONSE bits in the MFR\_FAULT\_RESPONSE register.
- Notifies the host using  $\overline{\text{FLT}}$  assertion.

## **OT\_WARN\_LIMIT (51h)**

The OT\_WARN\_LIMIT command sets the temperature, in degrees Celsius, of the on-chip temperature sensor at which an overtemperature warning is detected.

The 2 data bytes are in DIRECT format. Valid values are the same as the OT\_FAULT\_LIMIT.

The default OT\_WARN\_LIMIT value is 00h.

In response to the OT\_WARN\_LIMIT being exceeded, the MAX8688:

- Sets the TEMPERATURE bit in the STATUS\_BYTE.
- Sets the OT\_WARN bit in the MFR\_FAULT\_STATUS register.
- Notifies the host through  $\overline{\text{FLT}}$  using assertion.

## **TON\_DELAY (60h)**

TON\_DELAY sets the time, in milliseconds, from when a start condition is received (a valid OPERATION command or through A3/ONOFF when enabled) until the POL output voltage starts to rise. During TON\_DELAY, the POL is disabled (ENOUT deasserted) until TON\_DELAY expires. Also, the undervoltage fault and warning are masked off during TON\_DELAY.

The 2 data bytes are in DIRECT format. Valid values are from 0 to 3276.7ms.

The default TON\_DELAY value is 0ms.

## **TON\_RISE (61h)**

The TON\_RISE sets the time, in milliseconds, from when the POL output voltage starts to rise until the voltage has entered the regulation band. During TON\_RISE, the voltage, current, and temperature-related faults and warnings are masked off. Meanwhile, the MAX8688 still responds to the PMBus command. If a TON\_RISE parameter results in the DAC outputting an out-of-range value (valid range 0 to 4090) immediately during TON\_RISE, the CML flag is set and  $\overline{\text{FLT}}$  asserts to issue a warning.

In feedback mode, the MAX8688 leaves the S1 switch on the DAC open during soft-start. It waits for the TON\_RISE time to expire before adjusting the DAC output to equal the DACOUT feedback and then closes S1.

The 2 data bytes are in DIRECT format. In REFIN mode, the TON\_RISE parameter is a 16-bit value and the valid values are from 0.01ms to 32.767ms. In FB mode, the TON\_RISE is a 14-bit value and the valid values are from 0.01ms to 16.383ms (the upper 2 bits are ignored).

The default TON\_RISE value is 0.01ms. Setting any value less than this minimum value defaults back to 0.01ms.

## **TOFF\_DELAY (64h)**

The TOFF\_DELAY sets the time, in milliseconds, from when a STOP condition is received (a soft-off OPERATION command or through A3/ONOFF when enabled) until the POL stops transferring energy to the output.

When commanded to turn off immediately through the OPERATION command, the TOFF\_DELAY value is ignored. When commanded to turn off through A3/ONOFF (when enabled), the TOFF\_DELAY parameter is used.

The 2 data bytes are in DIRECT format. Valid values are from 0 to 3276.7ms.

The default TOFF\_DELAY value is 0ms.

# Digital Power-Supply Controller/Monitor with PMBus Interface

## TOFF\_FALL (65h)

The TOFF\_FALL command sets the time, in milliseconds, from the end of the turn-off delay time until the output voltage is commanded to zero. Note that this command can only be used with a device whose output can sink enough current to cause the output voltage to decrease at a controlled rate.

When commanded to turn off immediately through the OPERATION command, the TOFF\_FALL value is ignored. When commanded to turn off through the OPERATION soft-off command or A3/ONOFF (when enabled), the TOFF\_FALL parameter is used. If a TOFF\_FALL parameter results in the DAC outputting an out-of-range value (valid range 0 to 4090) immediately during TOFF\_FALL, the CML flag is set and FLT asserts to issue a warning.

In feedback mode, this value is not used. The MAX8688 disables ENOUT and opens the DAC switch immediately after the TOFF\_DELAY.

The 2 data bytes are in DIRECT format. Valid values are from 0.01ms to 32.767ms.

The default TOFF\_FALL value is 0.01ms. Setting any value less than this minimum value defaults back to 0.01ms.

## STATUS\_BYTE (78h)

The STATUS\_BYTE command returns 1 byte of information with a summary of the most critical faults. In the MAX8688, status information is binary. A value of 1 indicates that a fault or warning has occurred and a 0 indicates otherwise. Bits for unsupported features shall be reported as 0.

The STATUS\_BYTE cannot be restored by RESTORE\_DEFAULT\_ALL command. The STATUS\_BYTE message content is described in Table 6.

This command is read only.

The default STATUS\_BYTE value is 40h (POL is off).

## READ\_VOUT (8Bh)

The READ\_VOUT command returns the actual measured (not commanded) output voltage across RS+ and RS-. If filter mode is enabled, the filtered value is returned.

The 2 data bytes are in DIRECT format. Valid values are the same as VOUT\_COMMAND.

The default READ\_VOUT value is 00h.

## READ\_IOUT (8Ch)

The READ\_IOUT command returns the measured output current in amperes across ISN+ and ISN-.

The 2 data bytes are in DIRECT format. Valid values are the same as IOUT\_OC\_FAULT\_LIMIT.

The default READ\_IOUT value is 00h.

## READ\_TEMPERATURE\_1 (8Dh)

The MAX8688 supports only one temperature reading, READ\_TEMPERATURE\_1. The MAX8688 returns the actual on-chip measured temperature in degrees Celsius.

The 2 data bytes are in DIRECT format. Valid values are the same as OT\_FAULT\_LIMIT.

The default READ\_TEMPERATURE\_1 value is 00h.

**Table 6. STATUS\_BYTE Message Contents**

BIT NUMBER	STATUS BIT NAME	MEANING
7	BUSY	A fault was declared because the device was busy and unable to respond. <b>(The MAX8688 does not support the BUSY bit. This bit always returns 0).</b>
6	OFF	This bit is asserted if ENOUT is presently disabling the POL, regardless of the reason, including simply not being enabled.
5	VOUT_OV	An output overvoltage fault has occurred.
4	IOUT_OC	An output overcurrent fault has occurred.
3	VIN_UV	An input undervoltage fault has occurred. <b>(The MAX8688 does not support the VIN_UV bit. This bit always returns 0).</b>
2	TEMPERATURE	A temperature fault or warning has occurred.
1	CML	A communication, memory, or logic fault has occurred.
0	OTHER	A fault or warning not listed in bits [7:1] has occurred. See the <i>MFR_FAULT_STATUS (D8h)</i> section for more information.

# Digital Power-Supply Controller/Monitor with PMBus Interface

## PMBUS\_REVISION (98h)

The PMBUS\_REVISION command returns the revision of the PMBus specification to which the MAX8688 is compliant.

The command has 1 data byte. Bits [7:5] indicate the revision of PMBus specification Part I to which the MAX8688 is compliant. Bits [4:0] indicate the revision of PMBus specification Part II to which the MAX8688 is compliant. The permissible values are shown in Table 7. This command is read only.

The default PMBUS\_REVISION value is 00h which indicates that the MAX8688 is compliant with Part I Rev 1.0 and Part II Rev 1.0.

**Table 7. PMBus Revision Data Byte Contents**

BITS [7:5]	PART I REVISION	BITS [4:0]	PART II REVISION
000	1.0	00000	1.0

## MFR\_ID (99h)

The MFR\_ID command returns the MAX8688 manufacturer's identification.

The default MFR\_ID value is 4D01h.

This command is read only.

## MFR\_MODEL (9Ah)

The MFR\_MODEL command returns the MAX8688 model number.

The default MFR\_MODEL value is 4101h.

This command is read only.

## MFR\_REVISION (9Bh)

The MFR\_REVISION command reads the ASCII characters that contain the MAX8688 revision number with a block read command.

The default MFR\_REVISION value is 3201h.

This command is read only.

## MFR\_SMB\_LOOPBACK (D0h)

The MFR\_SMB\_LOOPBACK command returns the data word previously received by the MAX8688. The SMBus master writes a data word to the MAX8688 using this command and then retrieves the data word. A valid communication channel is established if the master reads back the same word.

Note that if another command is sent in between the write MFR\_SMB\_LOOPBACK command and the read MFR\_SMB\_LOOPBACK command, the MAX8688 returns whatever last command data word it receives.

## MFR\_MODE (D1h)

The MFR\_MODE command is used to configure the MAX8688 to support manufacturer specific commands. The MFR\_MODE command is described in Table 8.

The default MFR\_MODE value is 00h.

**Table 8. MFR\_MODE Bit Definition**

BIT	BIT NAME	DESCRIPTION
15:8	Input Clock Time Factor	This is equivalent to the number of external clock cycles provided to CLKIO in 100μs - 2. $MFR\_MODE[15:8] = f_{EXT\_CLK}/10kHz - 2$ where $f_{EXT\_CLK}$ is the frequency of the external clock. For example, when $f_{EXT\_CLK} = 1MHz$ , $f_{EXT\_CLK}/10kHz = 100$ , $MFR\_MODE[15:8] = 100 - 2 = 98$ . Valid external input clock range is from 100kHz ( $MFR\_MODE[15:8] = 8$ ) to 2.5MHz ( $MFR\_MODE[15:8] = 248$ ).  These bits are ignored if the internal clock source is selected as the time base (Clock Source Select bit = 0)
7	Clock Out Enable	The Clock Out Enable bit allows the output of a 1MHz reference clock to CLKIO for synchronizing multiple MAX8688s. Setting this bit to 1 enables the 1MHz output on CLKIO. When this bit is cleared to 0, no reference clock is outputted.
6	A3 Control Enable	Setting this bit to 1 enables A3/ONOFF to function as a POL ON/OFF input control. Clearing this bit to 0 ignores the A3/ONOFF state and the MAX8688 is controlled by the OPERATION command alone. See the <i>A3/ONOFF Operation</i> section.

# Digital Power-Supply Controller/Monitor with PMBus Interface

Table 8. MFR\_MODE Bit Definition (continued)

BIT	BIT NAME	DESCRIPTION
5	EEPROM Lock Enable	The EEPROM Lock Enable bit is used to protect external EEPROM data from being overwritten. When this bit is set to 1, the STORE_DEFAULT_ALL command is ignored. The RESTORE_DEFAULT_ALL command is still valid. When this bit is cleared to 0, the STORE_DEFAULT_ALL command initiates a store configuration operation to the EEPROM attached to A1/SCLE and A2/SDAE.
4	Correction Bypass Enable	Correction Bypass Enable. Setting this bit to 1 disables a correction algorithm made to voltage, current, and temperature readings. Clearing this bit to 0 applies a correction algorithm to voltage, current, and temperature measurement, thus resulting in high-accuracy readings. For optimal operation, this bit should be cleared to 0.
3	Input Range Select	The Input Range Select bit determines the input range of RS+ and RS-. Setting this bit to 1 extends the input range to 5.5V. Clearing this bit to 0 sets the input range to 2.048V.  Prior to setting any voltage-related values, the user application must first configure the desired input range. All voltage-related commands use the selected input range to convert the commanded value into internal register values.  It is not recommended to change the input range selection while the POL is operating, since all voltage-related commands continue to refer to the input range that was in use when the commanded voltage was received. This results in unpredictable and catastrophic operation.
2	ENOUT Polarity Select	The ENOUT Polarity Select bit selects the ENOUT active-on polarity. Setting this bit to 1 configures the ENOUT asserted on-state the same as the default startup state. Clearing this bit to 0 configures the ENOUT deasserted off-state the same as the default startup state. In effect, writing a 1 to this bit means that the asserted state of ENOUT is the default startup state. See the <i>ENOUT Operation</i> section.
1	Feedback Mode Select	The Feedback Mode Select bit determines the MAX8688 operation mode. When this bit is set to 1, the MAX8688 operates in the feedback mode while when cleared to 0, the MAX8688 operates in the REFIN mode.
0	Clock Source Select	The Clock Source Select bit determines the MAX8688 reference clock time source. When the Clock Source Select bit is set to 1, an external clock must be supplied to CLKIO and is used as the MAX8688 reference clock. When this bit is cleared to 0, an internal clock is used.

### MFR\_VOUT\_CORRECTION\_RATE (D2h)

The MFR\_VOUT\_CORRECTION\_RATE command sets the frequency (Hz) at which the MAX8688 adjusts 1 LSB of DACOUT (0.5mV) after the voltage has entered the regulation band.

Correction Rate = 10kHz/MFR\_VOUT\_CORRECTION\_RATE

The 2 data bytes are formatted as positive integers. Valid values are from 1 to 65535. Setting this value to 0 disables the DACOUT adjustment in the regulation band.

The default MFR\_VOUT\_CORRECTION\_RATE value is 10 which is equivalent to a correction rate of 1kHz.

### MFR\_SAMPLE\_RATE (D3h)

The MFR\_SAMPLE\_RATE command sets the frequency (Hz) at which the POL output voltage, output current, and temperature fault/warning conditions are monitored.

Monitor Sample Rate = 10kHz/MFR\_SAMPLE\_RATE

The 2 data bytes are formatted as positive integers. Valid values are from 1 to 65535. Setting this value to 0 disables all fault/warning monitoring.

The default MFR\_SAMPLE\_RATE value is 50 which is equivalent to a sample rate of 200Hz.

# Digital Power-Supply Controller/Monitor with PMBus Interface

## MFR\_VOUT\_PEAK (D4h)

The MFR\_VOUT\_PEAK command returns the maximum actual measured (not commanded) output voltage in volts across RS+ and RS-. If the filter mode is enabled, instead of returning the instantaneous value, the filtered output voltage is returned. To reset this value to 0, write to this command with a data value of 0. Any other values written by this command are used as a comparison for future peak updates.

The 2 data bytes are in DIRECT format. Valid values are the same as VOUT\_COMMAND.

The default MFR\_VOUT\_PEAK value is 0.

## MFR\_IOUT\_PEAK (D5h)

The MFR\_IOUT\_PEAK command returns the maximum measured output current in amperes across ISN+ and ISN-. To reset this value to 0, write to this command with a data value of 0. Any other values written by this command are used as a comparison for future peak updates.

The 2 data bytes are in DIRECT format. Valid values are the same as IOUT\_OC\_FAULT\_LIMIT.

The default MFR\_IOUT\_PEAK value is 00h.

## MFR\_TEMPERATURE\_PEAK (D6h)

The MFR\_TEMPERATURE\_PEAK command returns the maximum actual on-chip measured temperature in degrees Celsius. To reset this value to its lowest value, write to this command with a data value of 0FFFFh. Any other values written by this command are used as a comparison for future peak updates.

The 2 data bytes are in DIRECT format. Valid values are the same as OT\_FAULT\_LIMIT.

The default MFR\_TEMPERATURE\_PEAK value is 00h.

## MFR\_FILTER\_MODE (D7h)

The MFR\_FILTER\_MODE command is used to set VOUT sample count and sample delays.

**Table 9. MFR\_FILTER\_MODE Bit Definition**

BITS	BIT NAME	DESCRIPTION
15:8	Sample Delay	The upper byte defines the time interval between each sample. The sampling delay is $1.75\mu\text{s} + \text{MFR\_FILTER\_MODE}[15:8] \times 250\text{ns}$ .
7:0	Sample Count	The lower byte defines the number of samples to acquire in each monitoring sequence. The number of samples is determined by $2^{\wedge} \text{MFR\_FILTER\_MODE}[7:0]$ .

Whenever filtering is enabled (MFR\_FILTER\_MODE[7:0] not equal to 0), voltage-related readings are computed as an average over the sample count. Fault and warning limits are compared against the averaged value to determine if a fault/warning has occurred. The Sample Delay bit value (MFR\_FILTER\_MODE[15:8]) sets the time between successive voltage readings. Note that when filtering is disabled (MFR\_FILTER\_MODE[7:0] = 0), the Sample Delay bit value is ignored.

The default MFR\_FILTER\_MODE value is 00h (1 Sample Count bit and no delay). When filtering is in progress, the PMBus command is ignored.

## MFR\_FAULT\_STATUS (D8h)

When a warning or fault condition is detected, the MAX8688 sets the corresponding bit in the MFR\_FAULT\_STATUS register to 1 and notifies the host using FLT assertion. The STATUS\_BYTE is computed from MFR\_FAULT\_STATUS[7:0].

**Table 10. MFR\_FAULT\_STATUS Bit Definition**

BIT	FAULT/WARNING BIT NAME
15	Reserved. Read returns 0.
14	OT_WARN
13	OT_FAULT
12	IOUT_OC_WARN
11	IOUT_NC_FAULT
10	VOUT_UV_WARN
9	VOUT_UV_FAULT
8	VOUT_OV_WARN
7	Reserved. Read returns 0.
6	OFF
5	VOUT_OV_FAULT
4	IOUT_OC_FAULT
3	Reserved. Read returns 0.
2	TEMPERATURE. Set when either OT_WARN or OT_FAULT is set.
1	CML
0	OTHER. Set when any bit (other than those temperature related bits) in the high byte is set.

This register is cleared to 0 together with the STATUS\_BYTE register by any of the fault/warning clearing methods mentioned earlier in the CLEAR\_FAULTS command.

# Digital Power-Supply Controller/Monitor with PMBus Interface

IOUT\_NC\_FAULT is set to 1 when a negative current flow is detected.

The MFR\_FAULT\_STATUS command value cannot be restored by the RESTORE\_DEFAULT\_ALL command.

This command is read only.

## MFR\_FAULT\_RESPONSE (D9h)

The MFR\_FAULT\_RESPONSE command specifies the response to each fault condition supported by the MAX8688. Each fault has 2 response bits that describe how the MAX8688 should respond to that particular fault. It is also used to record the condition under which a fault occurs.

The STORE\_PEAK function is used to store peak values (MFR\_VOUT\_PEAK, MFR\_IOUT\_PEAK, and MFR\_TEMPERATURE\_PEAK) to the EEPROM (if present) on a fault detection regardless of the status of the EEPROM Lock Enable bit. Setting the STORE\_PEAK bit to 1 enables the store function.

**Table 11. MFR\_FAULT\_RESPONSE Bit Definition**

BITS	FAULT RESPONSE BIT NAME
15	STORE_PEAK
14:10	Reserved
9:8	NC_FAULT_RESPONSE[1:0]
7:6	OT_FAULT_RESPONSE[1:0]
5:4	IOUT_OC_FAULT_RESPONSE[1:0]
3:2	VOUT_UV_FAULT_RESPONSE[1:0]
1:0	VOUT_OV_FAULT_RESPONSE[1:0]

Table 12 describes how the MAX8688 responds to fault conditions. If the fault response requires ENOUT to be deasserted, ENOUT deasserts immediately. Meanwhile the DAC output ramps down slowly. The fault bit is cleared according to the *Fault Management and Reporting* section.

If ENOUT is deasserted due to a fault condition, the POL shall remain OFF until instructed to change.

The default MFR\_FAULT\_RESPONSE value is 00h.

**Table 12. Fault Response Options**

RESPONSE [1:0]	FAULT RESPONSE OPTION
11	Reserved. Same response as 00 except this option also stores peak data to EEPROM if enabled.
10	Set the corresponding fault bit in the fault status register, assert $\overline{\text{FLT}}$ , shutdown the POL (deasserted ENOUT), and restart the POL every T ( $\mu\text{s}$ ), where T is set in the MFR_FAULT_RETRY register. Store peak data to EEPROM if enabled.
01	Set the corresponding fault bit in the fault status register, assert $\overline{\text{FLT}}$ , and shutdown the POL. Store peak data to EEPROM if enabled.
00	Set the corresponding fault bit in the fault status register, assert $\overline{\text{FLT}}$ , and continue operation without any action.

## MFR\_FAULT\_RETRY (DAh)

The MFR\_FAULT\_RETRY command sets the time between restarting the POL if the fault response is to restart the POL at specified intervals. This command sets the retry time delay in multiples of 100 $\mu\text{s}$ . This command value is used for all fault responses that require delay retry.

$$\text{Delay retry time} = \text{MFR\_FAULT\_RETRY}[15:0] \times 100\mu\text{s}$$

The 2 data bytes are in DIRECT format. Valid values are from 0 to 3.2768s. When MFR\_FAULT\_RETRY = 00h, the MAX8688 restarts the POL at the next available time period.

The default MFR\_FAULT\_RETRY value is 00h.

## MFR\_SET\_ADDRESS (DBh)

The MFR\_SET\_ADDRESS command is used to change the MAX8688 slave address. By default the MAX8688 address is set by A3:A1 upon reset according to Table 3. After reset, the slave address can be changed by the MFR\_SET\_ADDRESS command. See the *MAX8688 Address Assignment* section.

This command has 2 data bytes. The slave address is contained in bits [6:0] of the first data byte. Bit 7 of the first data byte must be 0.

# Digital Power-Supply Controller/Monitor with PMBus Interface

## Performance Consideration

The MAX8688 can be viewed as a task scheduler where it periodically goes through its task list and performs the required tasks. While it may be tempting to monitor the POL at the highest supported frequency, MFR\_SAMPLE\_RATE, it must be noted that doing so takes away resources from other tasks, such as communication with the system controller or adjusting the DACOUT voltage. The same is true with employing an increasing number of MFR\_SAMPLE\_RATE and MFR\_FILTER\_MODE parameters. Since each application is unique in its own merit, it is impossible to prescribe a solution that suffices in all conditions. System designers are thus urged to derive optimum configuration based on the particular system needs.

## Graphic User Interface (GUI)

The MAX8688 evaluation kit comes with a free GUI that eliminates the need for any software development and provides a simple and user-friendly method for configuring large systems in a short time. Once the configuration is complete, the results can be saved to the external EEPROM for MAX8688 configuration on power-up or loaded at power-up onto the MAX8688 through the PMBus by a master controller. The powerful MAX8688 feature set can be inferred from the GUI screenshot shown in Figure 17, where the programmable parameters are displayed. These parameter values set serve as data bytes for PMBus and manufacturer-specific commands supported by the MAX8688. For details on using the GUI, refer to the MAX8688 evaluation kit.

## PCB Considerations

PCB layout for the MAX8688 is simple. It is easy to achieve accurate voltage and current measurement and voltage regulation by following these guidelines for good PCB layout:

- 1) Place IC decoupling and filter capacitors for AVDD, DVDD, REFO, RS\_C, and ISN\_C as close to the IC pins as possible. If using an external EEPROM, place it close to the MAX8688 and use short direct traces for interconnections.
- 2) Use Kelvin connections for the traces from the ISN+ and ISN- to the current-sense resistor for accurate current sensing. In the case of DCR sensing (see the *Current Sensing* section), connect the RC filter across the POL output inductor terminals using Kelvin connections. Route differential pair traces from the capacitor of the RC filter to ISN+ and ISN-.
- 3) Use Kelvin connections for the differential pair traces from the desired remote-sense points on the POL output-voltage power plane to RS+ and RS- of the MAX8688 for accurate POL output-voltage sensing.
- 4) Connect the analog ground (AGND) and digital ground (DGND) of the MAX8688 to a ground plane right at the IC. Terminate all other ground connections to this ground plane. Connect this ground plane to the quiet analog ground plane of the POL so that the reference voltage to the POL is unaffected by switching noise. Use a single-point (Star) grounding technique to connect the analog ground plane of the POL to the heat dissipating power ground plane of the POL. Place the MAX8688 as close as possible to the POL for best temperature measurement performance.
- 5) Refer to the MAX8688 evaluation kit for sample layout.

# Digital Power-Supply Controller/Monitor with PMBus Interface

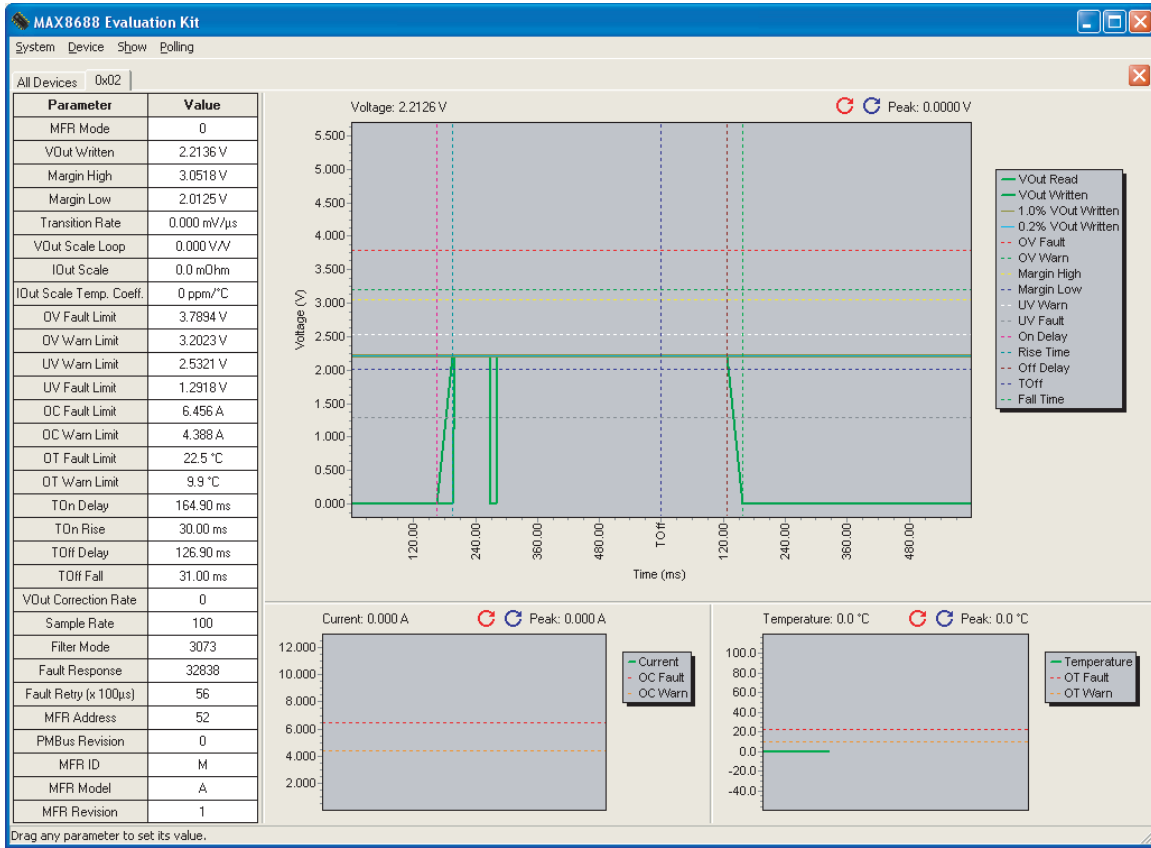
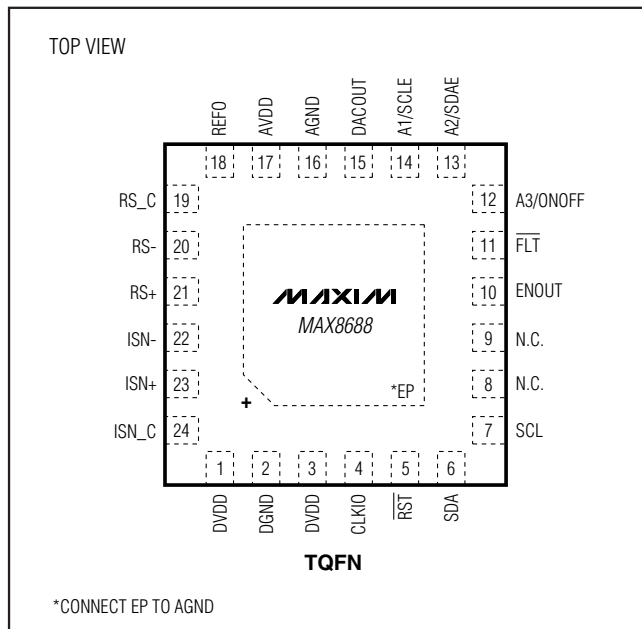

Figure 17. MAX8688 Graphic User Interface

# Digital Power-Supply Controller/Monitor with PMBus Interface

## Pin Configuration



## Package Information

For the latest package outline information and land patterns (footprints), go to [www.maxim-ic.com/packages](http://www.maxim-ic.com/packages). Note that a "+", "#", or "-" in the package code indicates RoHS status only. Package drawings may show a different suffix character, but the drawing pertains to the package regardless of RoHS status.

PACKAGE TYPE	PACKAGE CODE	OUTLINE NO.	LAND PATTERN NO.
24 TQFN-EP	T2444+4	<a href="#">21-0139</a>	<a href="#">90-0022</a>

MAX8688

# Digital Power-Supply Controller/Monitor with PMBus Interface

## Revision History

REVISION NUMBER	REVISION DATE	DESCRIPTION	PAGES CHANGED
0	1/08	Initial release	—
1	12/09	Updated the <i>General Description, Ordering Information, Absolute Maximum Ratings, Electrical Characteristics, Typical Operating Characteristics, Pin Description, and Pin Configuration</i>	1–8, 37
2	2/11	Removed references to temperature compensation	1, 14, 35

Maxim cannot assume responsibility for use of any circuitry other than circuitry entirely embodied in a Maxim product. No circuit patent licenses are implied. Maxim reserves the right to change the circuitry and specifications without notice at any time.

38 **Maxim Integrated Products, 120 San Gabriel Drive, Sunnyvale, CA 94086 408-737-7600**

## Looking for pricing, stock, or lifecycle information?

Click below to explore more details on WIN SOURCE:

- ⊖ [View MAX8688BHETG+ on WIN SOURCE](#)
- ⊖ [Maxim Integrated Information](#)

## Optimize Your Supply Chain with WIN SOURCE Solutions

- ✓ Global Sourcing Solution
- ✓ Obsolete Management
- ✓ Cost Control Management
- ✓ Shortage Management
- ✓ Alternative Solution
- ✓ Excess Inventory Management