



**THE DATASHEET OF
MAX7037EGL+**



General Description

The MAX7037 is an ultra-low-power, high-performance quad-band multichannel transceiver with integrated 8051 microcontroller, flash memory, and sensor interface. The MAX7037 runs from a minimum supply voltage of only 2.1V, extending battery life and enabling it to cope with different sources of energy, like solar cells, electromechanical or thermoelectrical energy. Hardware-implemented transmit-and-receive routines, in combination with a microcontroller, enable a high-efficiency transceiver system for wireless fail-safe multiband/multichannel communication with advanced FSK and ASK protocol features. Sleep modes allow easy implementation of low-power applications with fast reaction times.

Applications

- Ultra-Low-Power Sensor Networks
- Smart Metering
- Building Automation
- Short-Range Communication

Ordering Information appears at end of data sheet.

Benefits and Features

- Ultra-Low-Power Consumption for Battery-Based Operation
 - Current Consumption TX ($P_{OUT} = +6\text{dBm}$, FSK): 16mA
 - Current Consumption RX (FSK): 22mA
 - Current Consumption Deep Sleep Mode (Watchdog Timer and PRAM Active): 100nA
 - Supply Voltage Range: 2.1V to 5.5V
 - Integrated Ultra-Low-Power On/Off Voltage Threshold Detectors
- Worldwide Usable Frequency Band Coverage
 - ISM Band Frequency Coverage: 315/433/868/915~930MHz
- Fractional-N LO Generation For Multichannel Operation
 - RF Synthesizer Resolution: 244Hz/488Hz
- FFSK/FMSK/ASK Modulation for Optimum Compatibility with Various Communication Standards
 - Gross Data Rates: Up To 125Kbit/s
 - ASK with Programmable Transition Shape for Spectral Tuning
- Fully Integrated RF, TX, and RX Front-End for Minimum External Components
 - Maximum TX Output Power ($R_{LOAD} = 400\Omega$): +10dBm
 - RX Sensitivity (FFSK, BW = 150kHz): -100dBm
- Mixed-Signal Sensor Interface with Analog I/O Through ADC/DAC and On-Chip Buffers (Contact Factory for Future Support)
 - Integrated 9-Bit Sigma Delta ADC for Applications
 - Integrated 8-Bit DAC
 - 8 Mixed-Signal I/Os with Versatile Switching Matrix; Up to 18 Digital I/Os
- Wristwatch Crystal-Based Real-Time Clock (Contact Factory for Future Support)
 - Wristwatch Crystal Oscillator Integrated: 32768Hz

Absolute Maximum Ratings

Continuous Current In/Out of Pins±100mA
 Duration of Pin Short Circuit to Ground or Supply Continuous
 Duration of Short-Circuit Between Pins..... Continuous
 Continuous Power Dissipation (T_A = +70°C)
 Package 1 Multilayer Board
 (derate 37mW/°C above +70°C)2600mW
 Junction Temperature..... +150°C
 Operating Temperature Range..... -40°C to +85°C
 Storage Temperature Range..... -65°C to +150°C
 Lead Temperature (soldering, 10s) +300°C
 Supply Voltage at High-Voltage Supply Pins
 V_{DD} and V_{DDLIM}-0.5V to +6.0V
 Supply Voltage for Mixed-Signal Sensor Interface
 (GPIO1) and Extended Serial Interface 0 Pins
 (GPIO0)-0.5V to +6.0V
 Voltage at GPIO1 Port Pins (ADIO0~7) and GPIO2 Port Pins
 (WXIDIO, WXODIO) in Analog Mode.....-0.5V to 2.0V

Voltage at Digital Input Pins
 WAKE0, WAKE1, RESET GND.....-0.5V to 3.6V
 Voltage at GPIO2 Port Pins
 (WXIDIO, WXODIO) in digital mode.....-0.5V to 2.0V
 Voltage at GPIO0 Port Pins
 (BIST_DONE, TEST1, TEST3, SCSEDIO0,
 SCLKDIO1, WSDADIO2, RSDADIO3, BIST_PASS) and
 GPIO1 Port Pins (ADIO0~7) in Digital Mode-0.5V to 6.0V
 Maximum Permanent Elimination Current at the Parallel
 Regulator (Generally Limited by Max (V_{DD}) and PTOT)
 50mA
 Input Current Into Any Pin Except Supply Pins
 -50mA to +50mA
 Electrostatic Discharge Sensible Pins, as are:
 RFP, RFN, XTIN, XTOT, V_{DD}, V_{DDLIM}, UVDD, WAKE0,
 WAKE1, RESET2kV
 Electrostatic Discharge Normal Pins.....2kV
 Power Dissipation.....300 mW

Note 1: ESD Test according to AEC-Q100-002 (JESD22-A114): HBM: R = 1.5kΩ, C = 100pF. ESD protected to 2kV Human Body Model.

Stresses beyond those listed under "Absolute Maximum Ratings" may cause permanent damage to the device. These are stress ratings only, and functional operation of the device at these or any other conditions beyond those indicated in the operational sections of the specifications is not implied. Exposure to absolute maximum rating conditions for extended periods may affect device reliability.

Package Thermal Characteristics (Note 2)

40-Pin QFN (6mm x 6mm)
 Junction-to-Ambient Thermal Resistance (θ_{JA})27°C/W
 Junction-to-Case Thermal Resistance (θ_{JC}).....16.5°C/W

Note 2: Package thermal resistances were obtained using the method described in JEDEC specification JESD51-7, using a four-layer board. For detailed information on package thermal considerations, refer to www.maximintegrated.com/thermal-tutorial.

Electrical Characteristics

(Limits are 100% tested at T_A = 85°C. Limits over the operating temperature range and relevant supply voltage range are guaranteed by design and characterization.)

Operating Conditions

PARAMETER	SYMBOL	CONDITIONS	MIN	TYP	MAX	UNITS
Positive Supply Voltage	V _{DD}	At input pins V _{DD} and V _{DDLIM}	Min (V _{OFF})	3.3	5.5	V
Tolerated Supply Voltage Slope for Ambient Supply	V _{DDSLP}	Valid for rising and falling slope.	0	3	5	V/ms
Positive Supply Voltage at Shutdown	V _{DDS}	At input pins V _{DD} and V _{DDLIM} . No normal performance required.	Min (V _{OFF}) – 0.025			V
Supply Voltage for Mixed-Signal Sensor Interface and Extended Serial Interface 0 Pins	V _{IOVDD}	GPIO0/1	1.7	DVDD	5.5	V
Ground	GND			0		V

Electrical Characteristics (continued)

(Limits are 100% tested at $T_A = 85^\circ\text{C}$. Limits over the operating temperature range and relevant supply voltage range are guaranteed by design and characterization.)

Operating Conditions (continued)

PARAMETER	SYMBOL	CONDITIONS	MIN	TYP	MAX	UNITS
Logic Levels on Digital I/O Pins of GPIO0/1 Ports	V_L	All pins which are or can be configured as digital I/O.	Min (VIOVDD)		Max (VIOVDD)	
Tolerated Ripple on V_{DD}	V_{DDR}	100Hz ripple from full wave rectifier on V_{DD} whereas $\text{Min}(V_{DD}) > V_{ON}$			50	mV _{P-P}
ADC Measurement Input Common Mode Range		The sigma-delta ADCs have a differential input. The ADC input CMR is provided by the R2R buffer.	0		RVDD	V
ADC Measurement Input Amplitude for Single-Ended or Differential Measurements	VIN_MEAS	Measurement possible only via R2R input buffer. Possible selectable internal references: GND, RVDD, VADCCMR (~0.8V), VBG	0		±RVDD	Vd
Analog Input Range (GPIO1 Port, ADIO0~7)		Single-ended	0		VRVDD	V
Nominal Differential Load Resistance	R_{LOAD} (Note 3)	Resonance resistance R_{LOAD} at f_{CTX} of the load resonance circuit with the impedance Z_{LOAD} . Smaller R_{LOAD} values will lead to increased current consumption for equal POUT		400	900	Ω
RF Port DC Supply Voltage		RF_N, RF_P pins	Min (RVDD)	RVDD	Max (RVDD)	V
Differential Voltage Swing Between RF Pins	V_{TX}	Absolute Maximum Rating. Must be respected even if different load impedances are used			6.0	V _{P-P}
Required Relative 16M XTAL Frequency Tolerance for WB/DWB Operation	d_{fXO}	~315MHz band: ~433MHz band: ~868MHz band: ~915MHz band:			55 40 20 19	ppm ppm ppm ppm
TX-RX Carrier Frequency Deviation	d_{fTRD}	Application design requirement. Given by SAW based ASK transmitters			100	kHz
Ambient Operating Temperature	T_A		-40°C		+85°C	°C

Note 3: Maximum differential R_{LOAD} for +6dBm output power (based on $P = V^2/R$ formula and considering $RVDD_{MIN}$ and V_{DSAT} of output stage MOS).

Electrical Characteristics (continued)

(Limits are 100% tested at $T_A = 85^\circ\text{C}$. Limits over the operating temperature range and relevant supply voltage range are guaranteed by design and characterization.)

Current Consumption

PARAMETER	SYMBOL	CONDITIONS	MIN	TYP	MAX	UNITS
Current Consumption in RESET (<i>Off Mode</i>)	I_{DD_RESET}	Current into V_{DD} pin. RESET active.		15		nA
Current Consumption <i>Deep Sleep Mode</i>	I_{DD_DS}	On/Off threshold detectors, UVDD regulator and watchdog timer running.		100		nA
Current Consumption <i>Flywheel Sleep Mode</i>	I_{DD_FS}	On/Off threshold detectors, UVDD regulator, watchdog timer, wristwatch crystal and flywheel timer running.		700		nA
Current Consumption <i>Short-Term Sleep Mode</i>	I_{DD_SS}	On/Off threshold detectors, UVDD regulator, watchdog timer, short-term RCO and timer running.		3.4		μA
Current Consumption <i>CPUSTOP Mode</i>	$I_{DD_CPUSTOP}$			1		mA
Current Consumption <i>CPUIDLE Mode</i>	$I_{DD_CPUIDLE}$			1.3		mA
Current Consumption <i>CPU Mode – CRCO</i>	I_{DD_CRCO}	R/S/DVDD regulators, CPU RCO, and CPU 8051 at ~16MHz.		3.3		mA
Current Consumption <i>CPU Mode – XTAL</i>	I_{DD_XTAL}	R/S/DVDD regulators, XTAL 16M, and CPU 8051 at 16MHz.		3.9		mA
FLASH Program/Page Erase/Mass Erase Current		This current is additional to normal CPU Mode operating current.		< 7		mA
Current Consumption <i>TX Mode ASK</i>	I_{TX9A10_MO}	At ~868MHz and +10dBm available TX power during transmitting a PRBS sequence. CPU 8051 stopped.		23		mA
Current Consumption <i>TX Mode ASK</i>	I_{TX9A6_MO}	At ~868MHz and +6dBm available TX power during transmitting a PRBS sequence. CPU 8051 stopped.		16		mA
Current Consumption <i>RX Mode</i>	$I_{RX9_ASK/FSK}$	At ~868MHz: ASK or FSK, at maximum sensitivity. CPU 8051 stopped.		22		mA
Current Consumption <i>TX Mode ASK</i>	I_{TX3A10_MO}	At ~315MHz and +10dBm available TX power during transmitting a PRBS sequence. CPU 8051 stopped.		26		mA

Electrical Characteristics (continued)

(Limits are 100% tested at $T_A = 85^\circ\text{C}$. Limits over the operating temperature range and relevant supply voltage range are guaranteed by design and characterization.)

Current Consumption (continued)

PARAMETER	SYMBOL	CONDITIONS	MIN	TYP	MAX	UNITS
Current Consumption <i>TX Mode ASK</i>	$I_{\text{TX3A6_MO}}$	At ~315MHz and +6dBm available TX power during transmitting a PRBS sequence. CPU 8051 stopped.		20		mA
Current Consumption <i>RX Mode</i>	$I_{\text{RX3_ASK/FSK}}$	At ~315MHz: ASK or FSK, at maximum sensitivity. CPU 8051 stopped.		22		mA

Ambient Power Management and Voltage Regulators

PARAMETER	SYMBOL	CONDITIONS	MIN	TYP	MAX	UNITS
ADC BANDGAP						
Sigma-Delta ADC/Mixed-Signal I/O Bandgap Reference	V_{BGADC}		1.10	1.21	1.30	V
Bandgap Voltage Tolerance Magnitude	d_{VBG}	Overtemperature and process variations		< 4		%
Bandgap Voltage Tolerance Magnitude Over Temperature	d_{VBGT}	Overtemperature per device, related to room temperature		< ± 2		%
VOLTAGE LIMITER (SHUNT REGULATOR)						
Limitation Voltage of Shunt Regulator	$V_{\text{LIM_50mA}}$	At 50mA current sink	3.9	4.8	5.5	V_{DC}
Current Consumption Voltage Limiter Only	$I_{\text{LIM_3V5}}$	Current into V_{DDLIM} pin. $V_{\text{DD}} = 3.5\text{ V}$.		15		nA
Maximum Permanent Elimination Current of Limiter	I_{LIM}			50		mA
ON/OFF THRESHOLD DETECTION						
Turn-On Threshold Voltage	V_{ON}		2.3	2.45	2.6	V_{DC}
Shutdown Threshold Voltage	V_{OFF}	Automatic shutdown when not in sleep mode if V_{DD} drops below this level	1.82	1.92	2.10	V_{DC}

Electrical Characteristics (continued)

(Limits are 100% tested at $T_A = 85^\circ\text{C}$. Limits over the operating temperature range and relevant supply voltage range are guaranteed by design and characterization.)

Frequency Generation

PARAMETER	SYMBOL	CONDITIONS	MIN	TYP	MAX	UNITS
XTAL OSCILLATOR						
XTAL Oscillator frequency	f_{XO}			16.000		MHz
TX – RX Frequency Difference at Wideband Operation	d_{FTR_WB}	Within all frequency bands assuming equal XO tolerances in TX and RX		35		kHz
Crystal Oscillator Startup Time	t_{XOON}	Crystal ESR maximum 300 Ω		0.7	1.2	ms
WRISTWATCH XTAL OSCILLATOR						
Wristwatch XTAL Oscillator Frequency	f_{WXO}	2 (Note 15)		32.768		kHz
Wristwatch Crystal Oscillator Tolerance	df_{WXO}	Depends on application and used crystal tolerance. Oscillator circuit will add ~30% typ to crystal tolerance. Typical crystal tolerance assumed here: 30ppm		40		ppm
Wristwatch Crystal Oscillator Startup Time	t_{WXOON}	Crystal ESR maximum 50k Ω		1		s
RF SYNTHESIZER						
RF Synthesizer Type				Fractional N with three configurable ranges (B3, B4, B9).		–
RF Synthesizer Reference Frequency	f_{REF_RF}		–	f_{XO}	–	MHz
Low-Frequency Band Coverage	f_{RF_B3}		312		320	MHz
Mid-Frequency Band Coverage	f_{RF_B4}		431		465	MHz
High-Frequency Band Coverage	f_{RF_B9}		862		930	MHz
Low-Frequency Step Size	d_{fLO}	B3/B4 band: B9 band:		~244 ~488		Hz
RF Synthesizer Switching Speed	$t_{SYNTH_SW3/4/9}$	Settling to a frequency error of $\pm 10\text{kHz}$ from steady-state value		<50		μs
RF Synthesizer Turn-On Time	$t_{SYNTH_ON3/4/9}$	At turning on at available reference frequency settling to a frequency error of $\pm 10\text{kHz}$ from steady-state value			75	μs

Electrical Characteristics (continued)

(Limits are 100% tested at $T_A = 85^\circ\text{C}$. Limits over the operating temperature range and relevant supply voltage range are guaranteed by design and characterization.)

Frequency Generation (continued)

PARAMETER	SYMBOL	CONDITIONS	MIN	TYP	MAX	UNITS
DIGITAL CLOCK SYNTHESIZER						
Digital Clock Synthesizer Type				Integer N		–
Digital Clock Synthesizer Reference Frequency	f_{REFDC}		–	f_{XO}	–	MHz
Primary Digital Clock Frequency	f_{S0}	Synthesized by digital clock synthesizer		32.000		MHz
Digital Clock Synthesizer Turn-On Speed	$t_{f_{\text{S0_ON}}}$	At turning on at available reference frequency to a frequency error of $\pm 1\text{kHz}$ from steady-state value		< 75		μs
CPU RCO (CRCO)						
Nominal CRCO Frequency		Free-running frequency	11.7	16	20.0	MHz
CRCO Startup Time		From start of RCO to usable clock		4		Cycles

Electrical Characteristics (continued)

(Limits are 100% tested at $T_A = 85^\circ\text{C}$. Limits over the operating temperature range and relevant supply voltage range are guaranteed by design and characterization.)

Transmit Operation

PARAMETER	SYMBOL	CONDITIONS	MIN	TYP	MAX	UNITS
ASK TRANSMISSION						
Nominal ASK Transmit Data Rate	RTXA (Note 4)		31.25		125	kBit/s
ASK TX Data Rate Tolerance	d_{RTXA}			$< d_{\text{fXO}}$		ppm
ASK Transmit Filter Order			–	4	–	–
ASK Transmit Filter Type				Bessel		–
ASK Transmit Filter Bandwidth	BTXA	-3dB bandwidth		1.5/2 RTXA		kHz
Transmit DAC Resolution				6		Bit
Over Sampling of ASK TX Waveform				16		–
ASK Anti-Aliasing Filter Bandwidth	BAAA	-3dB bandwidth		1.5 RTXA		kHz
FSK TRANSMISSION						
ASK Carrier Leakage		Transmitting a long “L” sequence at POUT = 10dBm. Related to power high.		< -40		dB
Nominal FSK Transmit Data Rate	RTXF (Note 4)	Digital NCO based (derived from 16MHz XTAL)	31.25		125	kBit/s
FSK TX Data Rate Tolerance	d_{RTXF}			$< d_{\text{fXO}}$		ppm
FSK Transmit Filter Order			–	2	–	–
FSK Transmit Filter Type				Bessel		–
FSK Transmit Filter Bandwidth	BTXF	-3dB bandwidth		1.5/2 RTXF		kHz
Magnitude of FSK Frequency Deviation	d_{fTXF} (Note 4)	Digital NCO based (derived from 16MHz XTAL)	4	RTXF/4 (for MSK)	60	kHz
ASK AND FSK TRANSMISSION						
TX power steps	NPTX			7		–
Maximum Available TX Output Power, Into Resonant Circuit with R_{LOAD} (Differential)	PTX (Note 1)	For ASK: TX power during physical ‘H’		-2 to +10		dBm
TX Output Power Variation Over Temperature	PTX_T (Note 1)	$T_A = -40^\circ\text{C}$ to $+85^\circ\text{C}$		$< \pm 1.5$		dB

Electrical Characteristics (continued)

(Limits are 100% tested at $T_A = 85^\circ\text{C}$. Limits over the operating temperature range and relevant supply voltage range are guaranteed by design and characterization.)

Transmit Operation (continued)

PARAMETER	SYMBOL	CONDITIONS	MIN	TYP	MAX	UNITS
Spurious Emission Power Transmitting At ~315Mhz At P_{OUT+10} Into Resonant Circuit With R_{LOAD} (Differential)	$POUT_SP3$ (Notes 2, 3)	$\approx 2 \times 315\text{MHz}$: $\approx 3 \times 315\text{MHz}$: $\geq 4 \times 315\text{MHz}$: (harmonics of US band)		< -29 < -29 < -21		 dBm dBm dBm
Spurious Emission Power Transmitting At ~433Mhz At P_{OUT+10} Into Resonant Circuit With R_{LOAD} (Differential)	$POUT_SP4$ (Notes 2, 3)	$\approx 2 \times 433\text{MHz}$: $\geq 3 \times 433\text{MHz}$: (harmonics of EU band)		< -16 < -10		 dBm dBm
Spurious Emission Power Transmitting At ~868Mhz At P_{OUT+10} Into Resonant Circuit With R_{LOAD} (Differential)	$POUT_SP8$ (Notes 2, 3)	$\approx 2 \times 868\text{MHz}$: $\geq 3 \times 868\text{MHz}$: (harmonics of EU band)		< -10 < -10		 dBm dBm
Spurious Emission Power Transmitting At ~915Mhz At P_{OUT+10} Into Resonant Circuit With R_{LOAD} (Differential)	$POUT_SP9$ (Notes 2, 3)	$\approx 2 \times 915\text{MHz}$: $\geq 3 \times 915\text{MHz}$: (harmonics of US band)		< -16 < -10		 dBm dBm

Note 1: Available TX power from the MAX7037 in reactive load with R_{LOAD} while transmitting at the transmit frequency f_{TX} . The TX power is measured by a matching network and a measurement balun single-ended on 50Ω level. The measurement result is backwards projected to the MAX7037 port by the known transfer function of the measurement balun and the matching network. Additionally, the radiated TX power is dependent on the (optional) RF-filter, antenna selectivity, and loss. Therefore, it will NOT be production tested.

Note 2: Spurious power generated by the MAX7037 in reactive load with R_{LOAD} while transmitting at the transmit frequency f_{TX} . Spurious emission values are measured by a matching network and a measurement balun single-ended on 50Ω level with a RBW of 100kHz being a replacement for the matching network and the differential antenna. The measurement result is backwards projected to the MAX7037 port by the known transfer function of the measurement balun and the matching network. Additionally, the radiated spurious emissions are dependent on the (optional) RF-filter, antenna-selectivity, and loss. Therefore, it will NOT production tested. Spurious emission suppression at carrier harmonics is also a part of filter and antenna design.

Note 3: Antenna and matching network loss and attenuation by antenna selectivity for spurious assumed to be at least 20dB. The (optional) RF filter is not taken into account.

Note 4: Digital implementation parameter, not parametrically tested (covered by ATPG testing).

Electrical Characteristics (continued)

(Limits are 100% tested at $T_A = 85^\circ\text{C}$. Limits over the operating temperature range and relevant supply voltage range are guaranteed by design and characterization.)

Receive Operation

PARAMETER	SYMBOL	CONDITIONS	MIN	TYP	MAX	UNITS
Receiver Input Impedance (Differential)	RIN (Note 5)	For all frequency bands B3/B4/B9. LNACONF = "001001"		288~526 Typ: 400		Ω
Receiver Source Impedance (Differential)	RSOURCE	(Antenna impedance)		400		Ω
Receiving Protocol				SSB reception LSB or USB selectable		-
Receiving Mode				SSB reception LSB or USB selectable		-
Received Modulation Method				ASK or FSK		-
LNA Gain	GLNA	Switchable in NLNA steps		0/20		$\text{dB}_{V/V}$
LNA Gain Steps	NLNA			2		-
VGA Gain	G_IVGA G_QVGA	Switchable in NVGA steps		0/3/6/9/12/ 15/18/21		$\text{dB}_{V/V}$
VGA Gain Steps	NVGA			8		-
1dB Input Compression Point (In-Band)	ICP1	At highest sensitivity (LNA and VGA maximum gain)		-43		dBm
Dynamic Range Of Sigma-Delta ADC	DYNADC	Sinusoidal signal at 125kHz in 200kHz output bandwidth		78		dB
Data Oversampling Factor	OV	Different logical treatment in compatible asynchronous SOF	-	8	-	-
ASK/FSK RX Data Rate	RRX (Note 7)	ASK or FSK tested at maximum data rate. ASK: FSK:	min RTXA min RTXF	RTXA RTXF	max RTXA max RTXF	kBit/s
Acceptable Advanced TX-RX Data Rate Deviation	d_{RTRXA}	Tolerance of nominal FSK data rate between TX and RX.		$< 2 df_{XO}$		ppm
IF Magnitude Word Width				16		Bits
RSS Word Width				16		Bits
LTRSS Word Width				16		Bits
DOUBLE WIDEBAND OPERATION						
Nominal Intermediate Frequency Wideband Operation	f_{IFD}			250		kHz
Effective Receiver Bandwidth	BRXD	-3dB, defined by integrated digital IF filter	-	300	-	kHz
Magnitude Of FSK Frequency Deviation	df_{RXD} (Note 5)		15	df_{TX}	60	kHz

Electrical Characteristics (continued)

(Limits are 100% tested at $T_A = 85^\circ\text{C}$. Limits over the operating temperature range and relevant supply voltage range are guaranteed by design and characterization.)

Receive Operation (continued)

PARAMETER	SYMBOL	CONDITIONS	MIN	TYP	MAX	UNITS
Normal ASK Receiver Sensitivity At MAX7037 Input	S0RX3_D_A S0RX4_D_A S0RX9_D_A (Notes 1, 3)	At max RTXA, high LNA gain and max IF gain for SRQ (Note 2) at $-10^\circ\text{C} < T_A < +70^\circ\text{C}$		-95		dBm
Normal FSK Receiver Sensitivity At MAX7037 Input	S0RX3_D_F S0RX4_D_F S0RX9_D_F (Notes 1, 3)	At MSK with max RTXF, high LNA gain and max IF gain for SRQ (Note 2) at $-10^\circ\text{C} < T_A < +70^\circ\text{C}$		-95		dBm
Temperature Sensitivity Reduction	d_{S0D_T}	$-40^\circ\text{C} < T_A < -10^\circ\text{C}$ or $+70^\circ\text{C} < T_A < +85^\circ\text{C}$.		<3		dB
Receiver Sensitivity Reduction Caused By TX-RX Frequency Offset	d_{S0D_F}	For SRQ (Note 2) at maximum df_{TRW}		<4		dB
Receiver Sensitivity Reduction Caused By Data Rate Deviation	d_{S0D_R}	For SRQ (Note 2) at maximum d_{RTRXC}		<3		dB
Reduced FSK Receiver Sensitivity	S1RX3/4/9_D_F (Notes 1, 3)	At low LNA gain, for SRQ (Note 2) at $-10^\circ\text{C} < T_A < +70^\circ\text{C}$		-84		dBm
Maximum ASK Target Signal Input Level	PMAX_D_A (Note 1)	At max RTXA, high LNA gain and max IF gain for SRQ (Note 2) at $-10^\circ\text{C} < T_A < +70^\circ\text{C}$		-20		dBm
Target Blocking Mask	(Note 4)	Covered by digital tests		Figure 3		dBc
Equivalent IF Magnitude Bandwidth	BIFMAG_D			150		kHz
RSS Bandwidth	BRSS_D			10		kHz
RSS Settling Time	t_{RSS0_D} (Note 7)	Dominated by BRSS_D kHz RSS measurement bandwidth		150	250	μs
LTRSS Bandwidth	BLTRSS_D			1		kHz
LTRSS Settling Time	t_{RSS1_D} (Note 7)	Given by BLTRSS_D kHz measurement bandwidth		1.5	2.0	ms
Gain Control Switching Time	t_{GCD} (Note 7)	One cycle from highest gain to lower gain		typ (t_{RSS0_D})	max (t_{RSS0_D})	μs

Electrical Characteristics (continued)

(Limits are 100% tested at $T_A = 85^\circ\text{C}$. Limits over the operating temperature range and relevant supply voltage range are guaranteed by design and characterization.)

Receive Operation (continued)

PARAMETER	SYMBOL	CONDITIONS	MIN	TYP	MAX	UNITS
WIDEBAND OPERATION						
Nominal Intermediate Frequency Wideband Operation	f_{IFW}			125		kHz
Effective Receiver Bandwidth	BRXW	-3dB, defined by integrated digital IF filter	–	150	–	kHz
Magnitude Of FSK Frequency Deviation	df_{RXW} (Note 7)		15	df_{TX}	60	kHz
Normal ASK Receiver Sensitivity At MAX7037 Input	S0RX3_W_A S0RX4_W_A S0RX9_W_A (Notes 1, 3)	At max RTXA, high LNA gain and max IF gain for SRQ (Note 2) at $10^\circ\text{C} < T_A < +70^\circ\text{C}$		-100		dBm
Normal FSK Receiver Sensitivity At MAX7037 Input	S0RX3_W_F S0RX4_W_F S0RX9_W_F (Notes 1, 3)	At MSK with max RTX _F , high LNA gain and max IF gain for SRQ (Note 2) at $10^\circ\text{C} < T_A < +70^\circ\text{C}$		-100		dBm
Temperature Sensitivity Reduction	d_{S0W_T}	$-40^\circ\text{C} < T_A < -10^\circ\text{C}$ or $+70^\circ\text{C} < T_A < +85^\circ\text{C}$		<3		dB
Receiver Sensitivity Reduction Caused By TX-RX Frequency Offset	d_{S0W_F}	For SRQ (Note 2) at maximum df_{TRW}		<4		dB
Receiver Sensitivity Reduction Caused By Data Rate Deviation	d_{S0W_R}	For SRQ (Note 2) at maximum d_{RTRXC}		<3		dB
Reduced FSK Receiver Sensitivity.	S1RX3/4/9_W_F (Notes 1, 3)	At low LNA gain, for SRQ (Note 2) at $-10^\circ\text{C} < T_A < +70^\circ\text{C}$		-88		dBm
Maximum ASK Target Signal Input Level	PMAX_W_A (Notes 1, 3)	At max RTXA, high LNA gain, and max IF gain for SRQ (Note 2) at $-10^\circ\text{C} < T_A < +70^\circ\text{C}$		-20		dBm
Target Blocking Mask	(Note 4)	Covered by digital tests		Figure 4		dBc
Equivalent IF Magnitude Bandwidth	BIFMAG_W			75		kHz
RSS Bandwidth	BRSS_W			5		kHz
RSS Settling Time	t_{RSS0_W} (Note 7)	Dominated by BRSS_W kHz RSS measurement bandwidth		300	500	μs

Electrical Characteristics (continued)

(Limits are 100% tested at $T_A = 85^\circ\text{C}$. Limits over the operating temperature range and relevant supply voltage range are guaranteed by design and characterization.)

Receive Operation (continued)

PARAMETER	SYMBOL	CONDITIONS	MIN	TYP	MAX	UNITS
LTRSS Bandwidth	BLTRSS_W (Note 7)			500		Hz
LTRSS Settling Time	t_{RSS1_W} (Note 7)	Given by BLTRSS_W kHz measurement bandwidth		3	4	ms
Gain Control Switching Time	t_{GCW} (Note 7)	One cycle from highest gain to lower gain		Typ (t_{RSS0_W})	Max (t_{RSS0_W})	μs
GENERAL						
Image Rejection Untrimmed	XR3_IRJ XR4_IRJ XR9_IRJ	Untrimmed, at maximum RX sensitivity setting. Image signal in-band at LSB RX +2 f_{IF} above band center. Image signal in-band at USB RX -2 f_{IF} below band center		24		dB
Image Rejection Trimmed		Trimmed, at maximum RX sensitivity setting. Image signal in-band at LSB RX +2 f_{IF} above band center. Image signal in-band at USB RX -2 f_{IF} below band center See receive section for image rejection tuning and Figure 4.		34		dB
Available RX Low Power Leakage at $f_{LORX,X}$	PLOLeak (Note 6)	Low power in a differentially matching source resistor as load with LNA in high or low gain mode		< -50		dBm

Note 5: The RX sensitivity is measured close to the application by a single-ended on 50 Ω source through a balun and a matching network to the input impedance. The measurement result is forward projected to the MAX7037 port by the known transfer function of the balun and the matching network.

Note 6: Standard Receive Quality (SRQ) is a bit error probability (without error correcting coding) of 10^{-3} .

Note 7: The radiated sensitivity of the whole RX is dependent of the (optional) RF filter- and antenna- selectivity and loss is therefore NOT production tested.

Note 8: SRQ fulfilled with: Useful signal applied 3dB above the measured sensitivity limit, however not below maximum of $S0_X + 3\text{dB}$. Blocking signal un-modulated CW. This measurement method is slightly more restrictive than the EN300 220-1V 1.3.1 (2000) section 9.3.2 for class 2 receivers due to they are related to the nominal received carrier position instead of the band edges. Blocking is not production tested.

Note 9: Values from simulation. Actual obtained RIN is also dependent on the LNA_CONF configuration setting.

Note 10: Carrier generated by the MAX7037 in reactive load with R_{LOAD} while receiving at the frequency f_{TRX} . The leakage power is measured by a matching network and a measurement balun single-ended on 50 Ω level being a replacement for the matching network and the differential antenna. The measurement result is backwards projected to the MAX7037 port by the known transfer function of the measurement balun and the matching network. The radiated leakage is furthermore dependent on the (optional) RF-filter- and antenna- loss and, therefore, NOT production tested. Spurious emission suppression at carrier harmonics is also a part of filter and antenna design.

Note 11: Digital implementation parameter, not parametrically tested (covered by ATPG testing).

Electrical Characteristics (continued)

(Limits are 100% tested at $T_A = 85^\circ\text{C}$. Limits over the operating temperature range and relevant supply voltage range are guaranteed by design and characterization.)

TX and RX Timing Parameters

PARAMETER	SYMBOL	CONDITIONS	MIN	TYP	MAX	UNITS
STARTING AND RE-STARTING TX AND RX						
TX Starting Time	t_{0CT} (Notes 1, 2)	Time for starting transmitting a packet from turned off synthesizer. Dominated by synthesizer startup.		$<t_{SYNTH_ON}$		μs
TX Restarting Time	t_{CT} (Notes 1, 2)	Time for starting transmitting a packet at running synthesizer. Dominated by synthesizer switching.		$<t_{SYNTH_SW}$		μs
TX Continuing Time	t_T (Notes 1, 2)	Time for starting transmitting a packet at synthesizer running on correct channel.		$<t_{SYNTH_SW}$		μs
RX Starting Time	t_{0CR} (Notes 1, 2)	Time for starting receiving from turned off synthesizer. Dominated by synthesizer startup. LTRSS is forced		$<t_{SYNTH_ON}$ $+t_{RSS1x}$		μs
RX Restarting Time	t_{CR} (Notes 1, 2)	Time for starting receiving running synthesizer. Dominated by synthesizer switching. LTRSS is forced		$<t_{SYNTH_SW}$ $+t_{RSS1x}$		μs
RX Continuing Time	t_R (Notes 1, 2)	Time for starting receiving at synthesizer running on correct channel		t_{RSS0x} ~ t_{RSS1x}		μs
SINGLE CHANNEL (BAND) OPERATION						
TX->TX Switching Time Same RF Channel (Band)	t_{TT} (Notes 1, 2)	Time between transmitting two packets. Estimation, given by CPU 8051.		10		μs
TX->RX Switching Time Same RF Channel (Band)	t_{TR0} (Notes 1, 2)	At constant LTRSS, until packet start possible (for receiving at SRQ)		$<t_{RSS0x}$		μs
TX->RX Switching Time Same RF Channel (Band)	t_{TR1} (Notes 1, 2)	At totally different RSS where the LTRSS has to be adapted until packet start possible (for receiving at SRQ).		$<t_{RSS1x}$		μs
RX->TX Switching Time Same RF Channel (Band)	t_{RT} (Notes 1, 2)	Time between end receiving and start transmitting a packet. Estimation, given by CPU 8051.		10		μs
RX->RX Switching Time Same RF Channel (Band)	t_{RR0} (Notes 1, 2)	At constant LTRSS, until packet start possible (for receiving at SRQ).		$<t_{RSS0x}$		μs
RX->RX Switching Time Same RF Channel (Band)	t_{RR1} (Notes 1, 2)	At totally different RSS where the LTRSS has to be adapted until packet start possible (for receiving at SRQ).		$<t_{RSS1x}$		μs

Electrical Characteristics (continued)

(Limits are 100% tested at $T_A = 85^\circ\text{C}$. Limits over the operating temperature range and relevant supply voltage range are guaranteed by design and characterization.)

TX and RX Timing Parameters (continued)

PARAMETER	SYMBOL	CONDITIONS	MIN	TYP	MAX	UNITS
MULTI CHANNEL (BAND) OPERATION						
TX->TX Channel (Band) Switching Time	t_{TCT} (Notes 1, 2)	Time between transmitting two packets. Dominated by synthesizer switching.		$<t_{SYNTH_SW}$		μs
TX->RX Switching Time Other RF Channel (Band)	t_{TCR0} (Notes 1, 2)	At constant LTRSS, until packet start possible (for receiving at SRQ).		$<t_{SYNTH_SW}$ $+t_{RSS0x}$		μs
TX->RX Switching Time Other RF Channel (Band)	t_{TCR1} (Notes 1, 2)	At totally different RSS where the LTRSS has to be adapted until packet start possible (for receiving at SRQ).		$<t_{SYNTH_SW}$ $+t_{RSS1x}$		μs
RX->TX Switching Time Other RF Channel (Band)	t_{RCT} (Notes 1, 2)	Time between end receiving and start transmitting a packet. Dominated by synthesizer switching.		$<t_{SYNTH_SW}$		μs
RX->RX Switching Time Other RF Channel (Band)	t_{RCR0} (Notes 1, 2)	At constant LTRSS, until packet start possible (for receiving at SRQ).		$<t_{SYNTH_SW}$ $+t_{RSS0x}$		μs
RX->RX Switching Time Other RF Channel (Band)	t_{RCR1} (Notes 1, 2)	At totally different RSS where the LTRSS has to be adapted until packet start possible (for receiving at SRQ).		$<t_{SYNTH_SW}$ $+t_{RSS1x}$		μs

Note 1: SRQ fulfilled with: Useful signal applied 3dB above the measured sensitivity limit, however not below maximum of $S0_x + 3\text{dB}$.

Note 2: Timings are a composite of tested subtimings therefore laboratory evaluation only, not directly production tested.

Pin Configuration

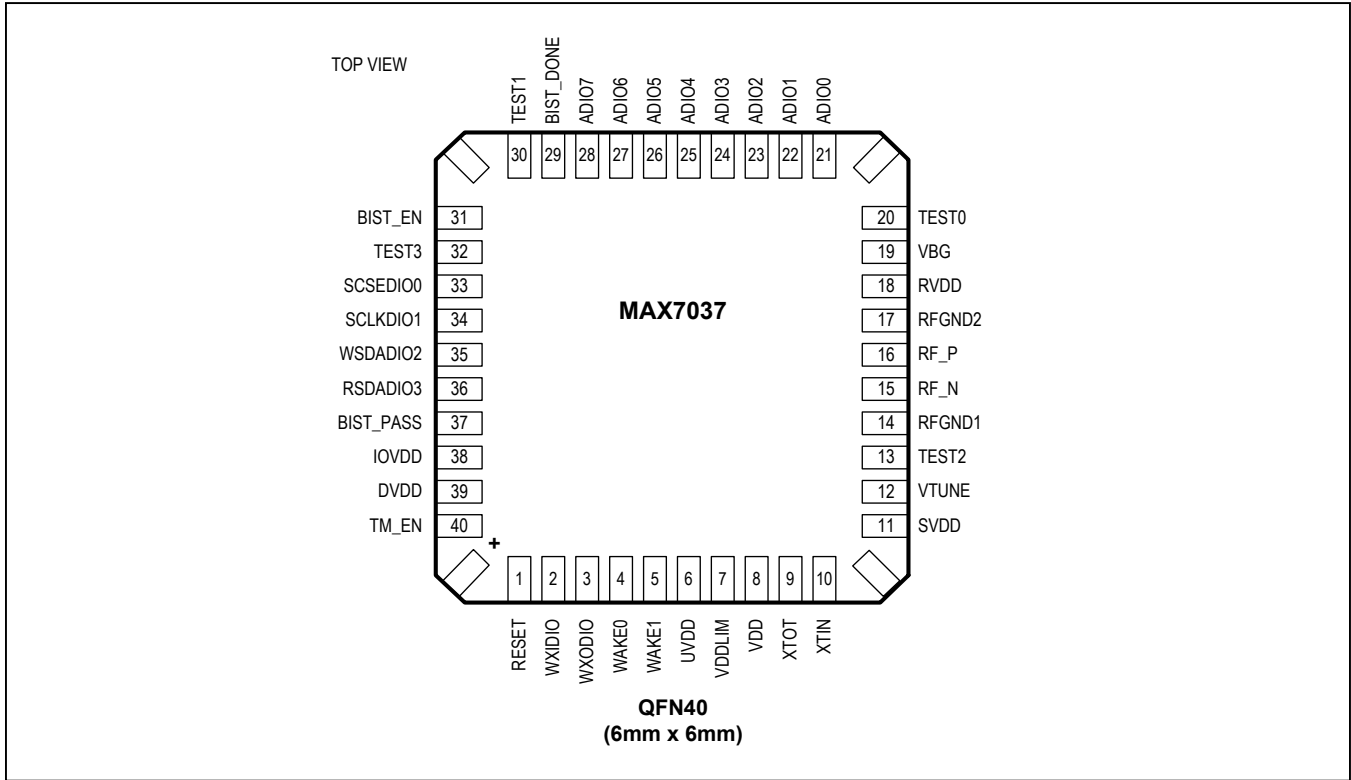

Pin Description

PIN	PIN NAME	DIRECTION	PAD TYPE	DESCRIPTION	SUPPLY/ IO VOLTAGE DOMAIN
1	RESET	DI	PD	External Reset Input. High active.	1.8
2	WXIDIO	ADIO	SPUPD	GPIO2 Group: Analog/Slow Digital I/O – 32kHz Oscillator XTAL Input	1.8
3	WXODIO	ADIO	SPUPD	GPIO2 Group: Analog/Slow Digital I/O – 32kHz Oscillator XTAL Output.	1.8
4	WAKE0	DI	S	Wake 0 Input.	1.8
5	WAKE1	DI	S	Wake 1 Input.	1.8
6	UVDD	AP		UVDD Regulator Output.	1.8
7	VDDLIM	A_HV		V _{DD} Limiter.	5
8	V _{DD}	A_HV		Main V _{DD} – Input for DVDD/SVDD/RVDD/UVDD regulators	5
9	XTOT	AO		16MHz XTAL Output	1.8
10	XTIN	AI		16MHz XTAL Input	1.8

Pin Description (continued)

PIN	PIN NAME	DIRECTION	PAD TYPE	DESCRIPTION	SUPPLY/ IO VOLTAGE DOMAIN
11	SVDD	AP		SVDD Regulator Output.	1.8
12	VTUNE	AIO		RF PLL Vtune Debug I/O.	1.8
13	TEST2	DI	PD	Test2	1.8
14	RFGND1	AG		RF GND	1.8
15	RF_N	AIO		RF I/O (n)	1.8
16	RF_P	AIO		RF I/O (p)	1.8
17	RFGND2	AG		RF GND	1.8
18	RVDD	AP		RVDD Regulator Output.	1.8
19	VBG	AIO		SD-ADC Bandgap Reference Buffered Output. Decoupling capacitor needed.	1.8
20	TEST0	DI	PD	Test0	3.3
21	ADIO0	ADIO	SPUPD	GPIO1 Group: Analog/Digital I/O.	3.3
22	ADIO1	ADIO	SPUPD	GPIO1 Group: Analog/Digital I/O.	3.3
23	ADIO2	ADIO	SPUPD	GPIO1 Group: Analog/Digital I/O.	3.3
24	ADIO3	ADIO	SPUPD	GPIO1 Group: Analog/Digital I/O.	3.3
25	ADIO4	ADIO	PUPD	GPIO1 Group: Analog/Digital I/O.	3.3
26	ADIO5	ADIO	PUPD	GPIO1 Group: Analog/Digital I/O.	3.3
27	ADIO6	ADIO	PUPD	GPIO1 Group: Analog/Digital I/O.	3.3
28	ADIO7	ADIO	PUPD	GPIO1 Group: Analog/Digital I/O.	3.3
29	BIST_DONE	ADIO	PD	GPIO0 Group: DIO5. BIST done output (BIST_EN = 1). Analog functionality only in test mode.	3.3
30	TEST1	DIO	PD	GPIO0 Group: DIO6. Test1 in test mode.	3.3
31	BIST_EN	DI	PD	BIST Enable.	3.3
32	TEST3	DIO	PD	GPIO0 Group: DIO7. Test3 in test mode.	3.3
33	SCSEDIO0	DIO	PUPD	GPIO0 Group: DIO0 – SPI Chip Select.	3.3
34	SCLKDIO1	DIO	PUPD	GPIO0 Group: DIO1 - SPI Clock.	3.3
35	WSDADIO2	DIO	PUPD	GPIO0 Group: DIO2 - SPI Data In.	3.3
36	RSDADIO3	DIO	PUPD	GPIO0 Group: DIO3 - SPI Data Out.	3.3
37	BIST_PASS	DIO	PD	GPIO0 Group: DIO4. BIST pass/fail output (BIST_EN=1).	3.3
38	IOVDD	DP		I/O V _{DD} .	3.3
39	DVDD	DP		Digital V _{DD} .	1.8
40	TM_EN	DI	PD	Test mode enable	1.8
41	GND	ADG		Exposed Pad. Connect to ground.	

Functional (or Block) Diagram

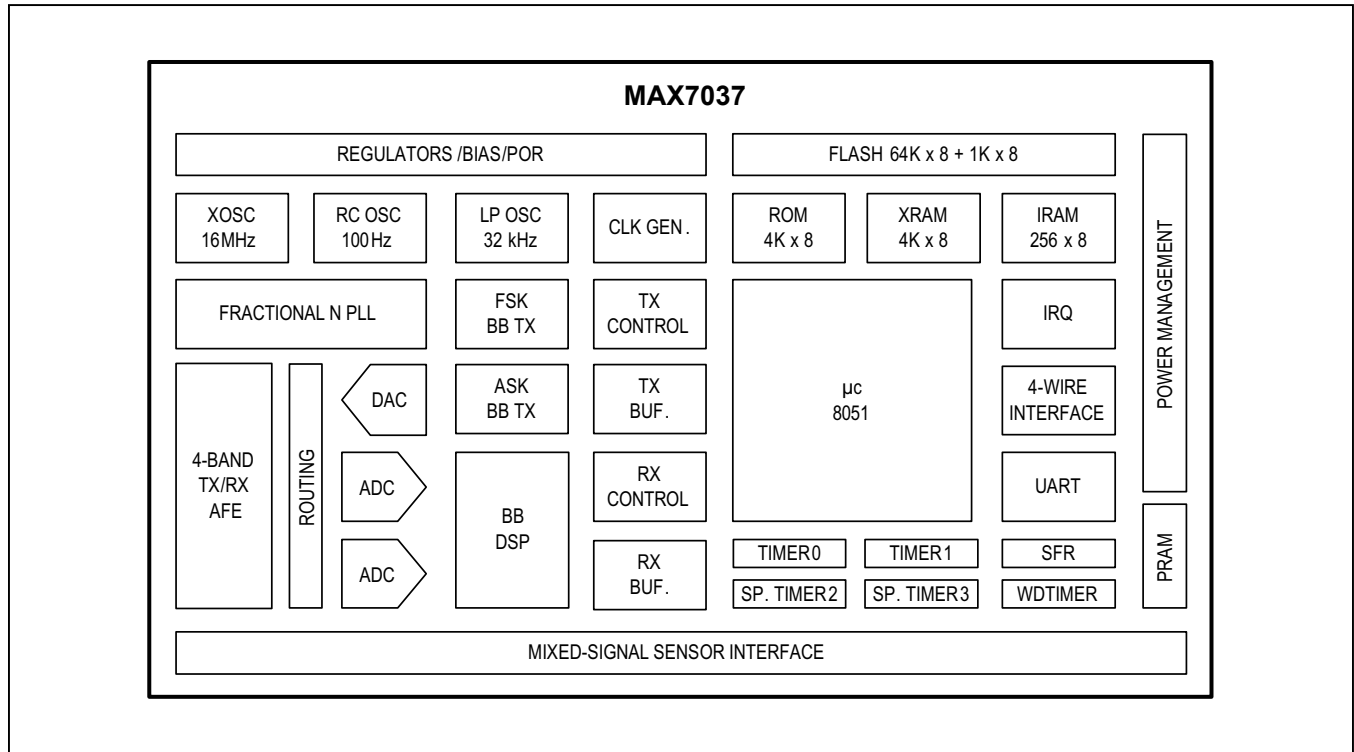

Detailed Description

Operation Modes

Overview

The MAX7037 provides three active modes, a deep sleep mode, and an off mode. The three active modes are:

- CPU Active mode
- RF Transmit mode
- RF Receive mode

CPU Active Mode

In CPU Active mode, the CPU is running normally¹, and executing application firmware from FLASH. This is the default mode after power-up.

This mode is typically used for TX/RX configuration, system management tasks, or mixed-signal sensor interface activity.

In order to switch to TX or RX activity, certain UART commands should be sent. See below section on [Communication](#).

RF Transmit Mode

The RF Transmit mode is a fully autonomous process controlled by the internal TX state machine (TX FSM), as well as the internal firmware. It requires the CPU to run on a stabilized XTO clock, an RF configuration, and the desired data to be written into the shared RX/TX data buffer. RF Transmit mode is controlled through the firmware and is described in detail in the [Communication](#) section below.

The following sequence will configure the MAX7037 for RF Transmit mode and transmit a packet of data. Strings that are sent to the MAX7037 are enclosed in double quotes in the description, but the quotes should not be included in the string.

- 1) Host sends the string "config_tx_radio N" through the UART to MAX7037 firmware. The value N is 1 through 6 inclusive and corresponds to the specific radio mode.
- 2) Host sends the string "write_tx_pkt 4 Byte1 Byte 2 ... Byte N" through the UART to MAX7037 firmware. Byte1, Byte2 etc. are replaced by the actual values of the bytes. For example, to send a packet containing byte values 14 58 34 137 216, one would send the string "write_tx_pkt 4 14 58 34 137 216". The maximum number of data byte values that can be included in the string is 59.
- 3) Host sends the string "send_pkt 1" through the UART to the MAX7037 firmware.
- 4) To send another different packet, without changing radio mode, go back to Step 2. Repeat steps 2 and 3 for every packet to be sent.

RF Receive Mode

Similar to the RF Transmit, the RF Receive mode is a fully autonomous process controlled by the internal RX state machine (RX FSM), as well as the internal firmware. It requires the CPU to run on a stabilized XTO clock and an RF configuration. RF Receive mode is controlled through the firmware, and is described in detail in the [Communication](#) section below.

The following sequence will configure the MAX7037 for RF Receive mode. Once in receive mode, the host can read out the received data. Strings that are sent to the

MAX7037 are enclosed in double quotes in the description, but the quotes should not be included in the string.

- 1) Host sends the string "config_rx_radio N" through the UART to MAX7037 firmware. The value N is 1 through 6 inclusive and corresponds to the specific radio mode.
- 2) Host sends the string "rx_pkt_start v" through the UART to MAX7037 firmware.
- 3) Host reads the characters received from the MAX7037 UART. Discard all characters until the string "Byte 1 = X\n" where X is the value of the byte and \n is the newline character. The remaining bytes of the packet will be received in the following characters of the string. For example, using the byte values given in the RF Transmit step-by-step instructions, the following will be received: "Byte 1 = 14\nByte 2 = 58\nByte 3 = 34\nByte 4 = 137\nByte 5 = 216\n". Host extracts the values for the data bytes and discards all other characters.
- 4) The MAX7037 will remain in receive mode, printing out all received packets to the UART until taken out of receive mode by receiving the command string "rx_pkt_stop" from the host. To demarc the end of one packet and the start of the next packet, host must scan for the string: "Byte 0 = X\n". This string will always be sent before the actual user data values of the packet. For example, if the string contains "Byte 1 = 14\nByte 2 = 58\nByte 3 = 34\nByte 4 = 137\nByte 5 = 216\nByte 0 = 15\nByte 1 = 35\n" then the host knows that the data bytes of one packet are 14, 58, 34, 137, 216, and the first byte of the next packet is 35.
- 5) Host sends the string "rx_pkt_stop" to terminate reception. To resume receive mode, without changing radio mode, go back to step 2.

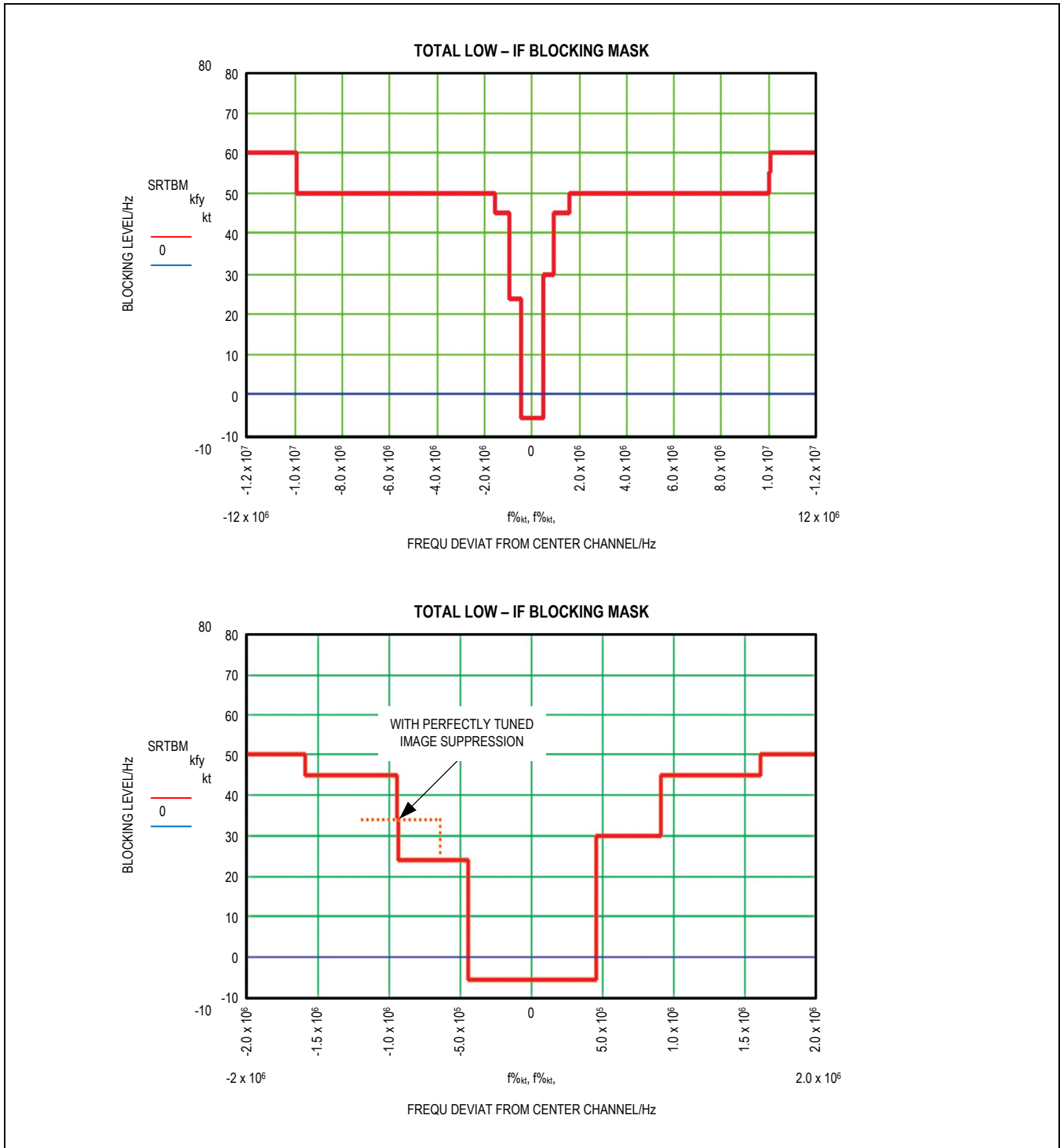

Figure 1. Blocking Mask of the Receiver at Double Wideband Operation. (Dotted line with perfect image rejection tuning. The image position may be swapped to upper side too. SRQ fulfilled with: Useful signal applied 3dB above the measured sensitivity limit. However, not below maximum of $S0_X + 3\text{dB}$. Blocking signal unmodulated CW.)

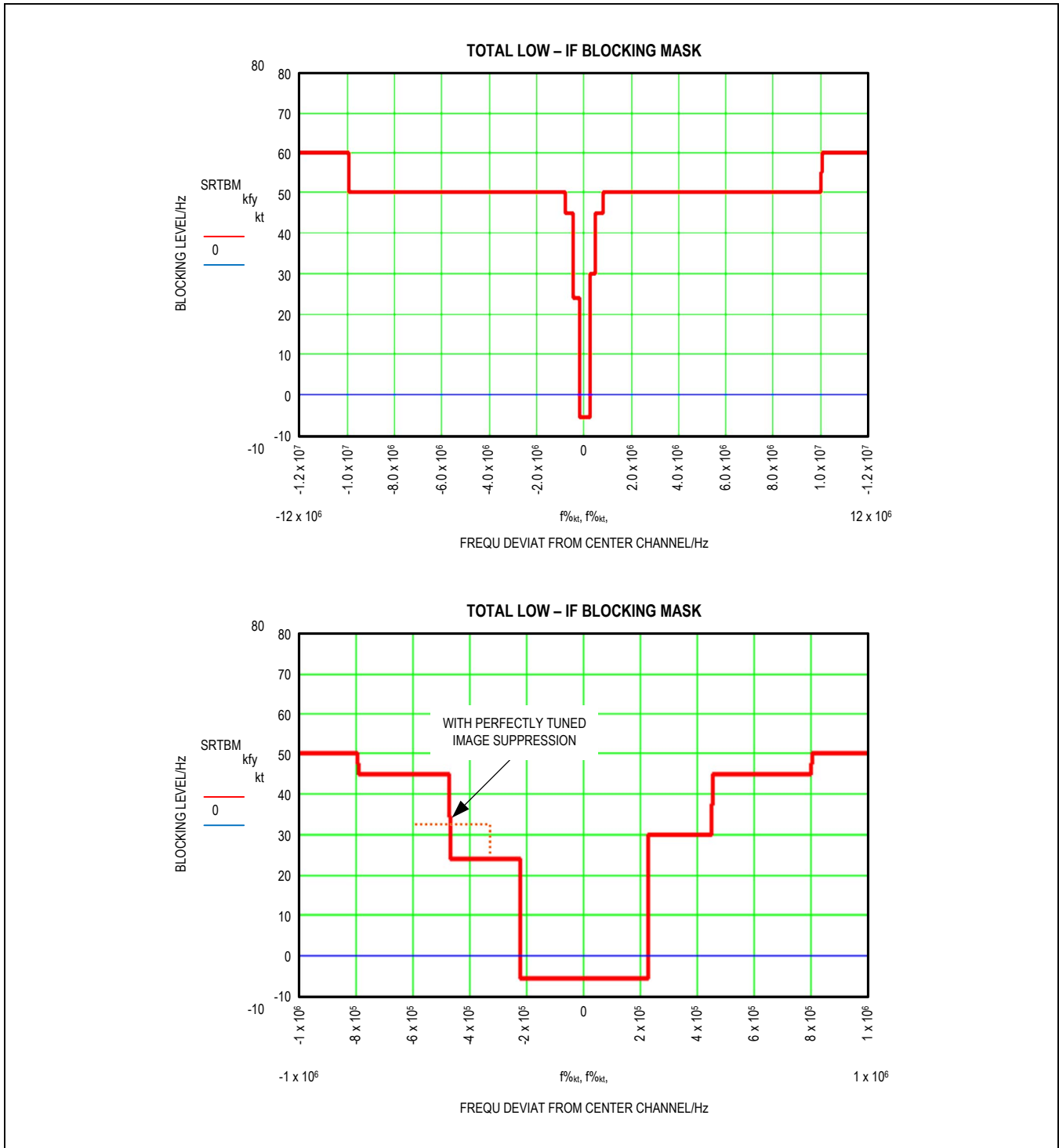

Figure 2. Blocking Mask of the Receiver at Wideband Operation. (Dotted line with perfect image rejection tuning. The image position may be swapped to upper-side too. SRQ fulfilled with: Useful signal applied 3dB above the measured sensitivity limit. However, not below maximum of $S0_X + 3\text{dB}$. Blocking signal unmodulated CW.)

Deep Sleep Mode

Deep Sleep mode is used for weak, ambient energy-powered, event-triggered TX applications, where ultra-low power consumption is a must. In Deep Sleep mode, only the ultra-low power blocks, excluding WXT0, flywheel timer and short-term timer, are active. Deep Sleep mode is interrupted periodically by an RCO-based, ultra-low-power watchdog timer to allow system polling. A change on the WAKE pins can also be used to exit Deep Sleep mode.

After wakeup from Deep Sleep mode, all configurations have to be re-established.

The system will transition directly from CPU STOP to Deep Sleep mode if there is no TX/RX Activity, and no other destination state is specified.

Off Mode

The MAX7037 is in Off mode when insufficient supply is available. There is no MAX7037 activity and the MAX7037 will not drain current from potentially weak energy sources.

The system will transition from Off mode to CPU Active mode when sufficient supply becomes available (i.e., $V_{DD} > V_{ON}$), as defined in the [Ambient Power Management and Voltage Regulators](#) section.

The MAX7037 will transition from any mode to Off mode, in a controlled manner, if the supply voltage (V_{DD}) falls below the off threshold (V_{OFF}) and enough battery charge is available to finish this operation. Further details can be found in the [Ambient Power Management and Voltage Regulators](#) section.

It is recommended that, prior to performing the flash write/erase operation, the supply voltage is measured to ensure that that sufficient energy exists to complete the operation. This ensures that the MAX7037 does not transition to Off mode during write/erase of the flash, leading to possible corruption.

Communication

Overview

This section deals with host CPU communication with the MAX7037. There are two topics discussed:

- 1) Configuration of IC through UART.
- 2) Download of firmware to flash memory through SPI.

UART Communications

The host CPU configures the MAX7037 through a set of defined commands. These are sent to the MAX7037 through the UART interface. The firmware, which is in flash memory and is executed by the 8051 microcontroller, implements a command handler routine. The firmware waits for a command to be received from the host. Once a command is received, it parses it, checks for validity of the command and any input arguments, then executes the command. Any command will cause some characters to be output to the host through the UART. For example, if an invalid command is sent, the firmware will respond with a text string indicating the non-validity of the command and prompting for a new command.

Host UART Settings

The configuration of the host UART must be as follows:

Baud Rate = 38400 bps
Data = 8 bits
Parity = None
One stop bit
No Flow Control

UART Pins and Timing

The Tx pin is ADIO7 (pin 28) and the Rx pin is ADIO6 (pin 27). The timing is the standard serial interface timing. A single start bit which is always 0 is followed by the 8 data bits, least significant bit first. The final 10th bit is a stop bit which is always 1. The bits are shifted into the Rx pin or out of the Tx pin at the baud rate of 38400 bits/sec so the duration of each bit is the reciprocal of the baud rate. Refer to the timing diagram in [Figure 3](#).

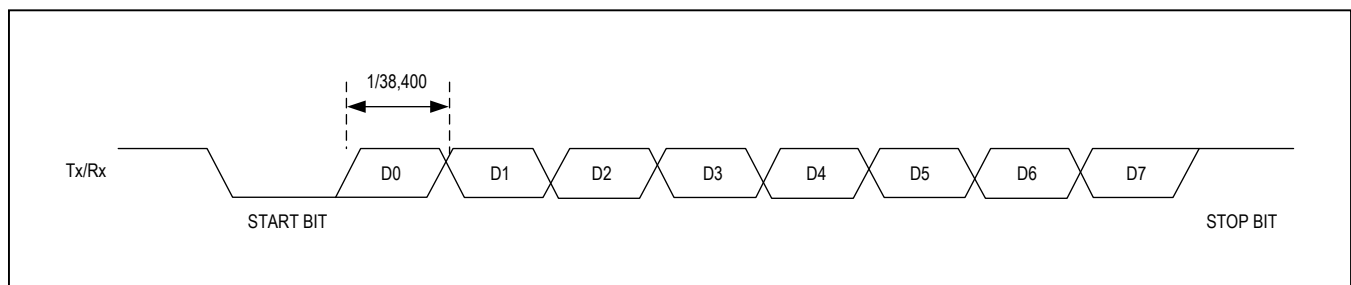

Figure 3. UART Timing Diagram

Commands

There are a set of commands available for configuring the MAX7037. The whole set can be seen by simply sending the string “help”. The result is shown in [Figure 4](#). If an invalid command is received, the firmware returns a string indicating the command is invalid. To get help for each command, send “help cmd” where cmd is replaced by the command string. For example, “help rssi” will cause the help text for the rssi command to be returned.

The detailed syntax of each command is provided in the following sections. Optional input parameters are enclosed in square parentheses. All input parameters must be separated by one or more space characters. A command is terminated with a newline character.

help [cmd]

The help command will cause a brief description of the command to be returned. The syntax is

```
>> help cmd
```

Where cmd is replaced by the actual command. If just help is input, then the set of commands is returned.

write_tx_pkt pkt_index [Byte1, Byte2, ..., ByteN]

The write_tx_pkt command is used to load the contents of a transmit packet into the data buffer. Either a predefined packet can be loaded or a user-defined packet.

pkt_index

The pkt_index input parameter is an integer with range [0:3] which is used to select one of four pre-defined packets. All four pre-defined packets have a fixed 2-byte preamble and 2-byte packet synchronization bit sequence comprising the packet header. The packet payload depends on the input parameters. The packet corresponding to pkt_index = 0 consists of 24 bytes of incrementing values with the exception of the first byte which specifies the length of the payload in bytes for all packets. The packet payload corresponding to pkt_index = 1 consists of 24 random byte values, again with the exception of the first byte which has a value of 24. The packet payload corresponding to pkt_index = 2 is 60 bytes of incrementing values, and the packet payload corresponding to pkt_index = 3 consists of 60 random byte values. If pkt_index is any value other > 3, then it is ignored and the user-specified payload defined by the optional Byte1, ..., ByteN input parameters are used instead. If a value of pkt_index > 3 is specified and there are no user-defined input parameters, then the firmware will return an error message without taking further action.

```

COM13 - Tera Term VT
File Edit Setup Control Window Help
Welcome to 7037 command line interface, type 'help' for available commands
>>help
The available commands are:
help
write_tx_pkt
write_rx_pkt
config_tx_radio
config_rx_radio
send_pkt
rx_pkt_start
rx_pkt_stop
reset_ber
ber_enable
ber_disable
read_ber
rssi
tx_interval
agc_enable
agc_disable
agc_thresh
agc_status
goto_deep_sleep
Each command has a help as well, ex: help read
>>

```

Figure 4: List of Available Commands

The four predefined packets have the following contents:

PACKET #0	PACKET #1	PACKET #2	PACKET #3
24	24	60	60
1	231	1	208
2	32	2	231
3	233	3	32
4	161	4	233
5	24	5	161
6	71	6	24
7	140	7	71
8	245	8	140
9	247	9	245
10	40	10	247
11	248	11	40
12	245	12	248
13	124	13	245
14	204	14	124
15	36	15	204
16	107	16	36
17	234	17	107
18	202	18	234
19	245	19	202
20	167	20	245
21	9	21	167
22	217	22	9
23	239	23	217
		24	239
		25	173
		26	193
		27	190
		28	100
		29	167

PACKET #0	PACKET #1	PACKET #2	PACKET #3
		30	43
		31	180
		32	8
		33	70
		34	11
		35	24
		36	210
		37	177
		38	81
		39	243
		40	8
		41	112
		42	97
		43	195
		44	203
		45	47
		46	125
		47	114
		48	165
		49	181
		50	193
		51	70
		52	174
		53	167
		54	41
		55	30
		56	127
		57	245
		58	87
		59	149

Byte1, Byte2, ..., ByteN

The user can define their own packet payload through the optional Byte1, ..., ByteN input parameters. Each parameter must be a value between 0 and 255 inclusive. If any value is outside of this range, it is replaced with 0 by the firmware. The firmware will count the number of bytes entered and automatically set the first byte of the payload to the length of the payload. Hence inputting N bytes results in a payload of N + 1 bytes, and a total packet length including the header of N + 5 bytes. The maximum payload length supported by MAX7037 is 60 bytes, so if more than 59 byte values are input, any byte values after the 59th one are ignored.

write_rx_pkt pkt_index [Byte1, Byte2, ..., ByteN]

The write_rx_pkt command is used to load the expected contents of a received packet into RAM inside the MAX7037. This is required for BER testing. The syntax and usage of the write_rx_pkt command are identical to that of the write_tx_pkt command.

send_pkt numTimes [contTx]

The send_pkt command causes the firmware to initiate transmission of the packet specified by the write_tx_pkt command. The same packet will be transmitted the number of times defined by the input parameter numTimes. One can specify continuous back-to-back transmission of the packet with the contTx input parameter.

numTimes

If numTimes = 0, then the packet will be continuously transmitted until stopped by reception of a “q” character. If numTimes is any value between 1 and 65535, the packet will be transmitted numTimes number of times, then transmission will stop automatically. The only legal values are 0 to 65535 inclusive. Between successive packet transmissions, the MAX7037 will ramp down the PA output power, pause, then proceed with the next packet transmission, ramping up the PA output power. For BER testing, this does not cause issues, and represents the normal operation of the device where it is sending or receiving one packet at a time. However, for testing of Tx spectral mask compliance, it is preferable to avoid having the PA keep turning off and on. To support this, the optional contTx input parameter is provided.

contTx

If the user provides a contTx input parameter, then it is read by the firmware. If the value is 0, then it is ignored. If non-zero, then the firmware ignores the numTimes parameter and instead just configures the MAX7037 to repeatedly loop through the data buffer causing the same packet to be transmitted continuously. This will continue

until reception of a “q” character. This mode differs from setting numTimes = 0 in that the transmitter circuitry does not power down between each packet transmission. This mode is provided to support transmit mask compliance testing.

tx_interval period

The tx_interval command is used to set the interval between successive packet transmissions.

period

The period input parameter is the interval in 10 millisecond units. The legal range of values is 2 through 255 inclusive. The default value is 100 resulting in one second between successive packet transmissions.

rx_pkt_start [verbose]

The rx_pkt_start command causes the firmware to configure the MAX7037 to receive packets. The MAX7037 remains in this state until the stop_pkt_rx command is received. If the optional input parameter, verbose, is sent, and has a value of “v”, then the contents of each received packet will be output to the terminal. If no input parameter is provided, then nothing is returned. Each time a packet is received, the MAX7037 will toggle the state of the GPIO output pin GPIO1.0 (pin 21). On the MAX7037 EV kit, this pin can be connected to an LED (through appropriate setting of a DIP switch), which will toggle on and off to give a visual indication of packet reception.

Once the rx_pkt_start command has been issued, there are only four commands that can be sent: reset_ber, read_ber, rssi and rx_pkt_stop. Once the rx_pkt_stop command is received by the firmware, it will return full control to the user so that the whole set of commands are available.

rx_pkt_stop

The rx_pkt_stop command causes the firmware to configure the MAX7037 to stop reception of packets. Any reception of any packet that is being received when the command is issued will be completed, after which the reception will be stopped gracefully.

ber_enable

The ber_enable command is used to enable bit error rate measurements. This command would be issued to a MAX7037 configured as a receiver prior to starting packet transmission at a MAX7037 configured as a transmitter. The data field of all packets received will be compared against the expected pattern (programmed with the write_rx_pkt command). Any bit mismatches are counted and the BER is reported as the ratio of errored bits to total bits.

The BER can be read at any time during the test through the `read_ber` command.

ber_disable

The `ber_disable` command is used to disable bit error rate measurements. This command would be issued to a MAX7037 configured as a receiver in order to terminate a BER measurement. Disabling the BER measurement does not affect the current value of the reported BER. It will simply stop changing. If BER is enabled again, the BER value will continue being updated from the current value.

reset_ber

The `reset_ber` command causes the BER value maintained in firmware to be cleared to zero. This command can be issued at any time.

read_ber

The `read_ber` command returns the current BER value. This command can be issued at any time. The BER value is actually output as two values, both 32-bits. The first value is the numerator of the BER which is the number of errored bits. The second value is the denominator of the BER which is the total number of bits compared. The host

can do the division to compute the BER. For example, if the BER is $\sim 10^{-4}$, the output from the firmware may be like the following:

```
>> read_ber
>> BER = 2/16415
```

rssi

The `rssi` command returns the current RSSI (Received Signal Strength Indicator) value. This command can be issued at any time. The value returned will be 0 if no packets have yet been received since reset, otherwise the value will be the peak RSSI of the last packet received. [Figure 5](#) shows an approximate mapping of RSSI value to received signal level.

config_tx_radio [cfgldx]

The `config_tx_radio` command is used to configure the radio for transmission. For example, to configure a MAX7037 to transmit using FSK, 315MHz center frequency, 31.25Kbps one would send the command:

```
config_tx_radio 3
```

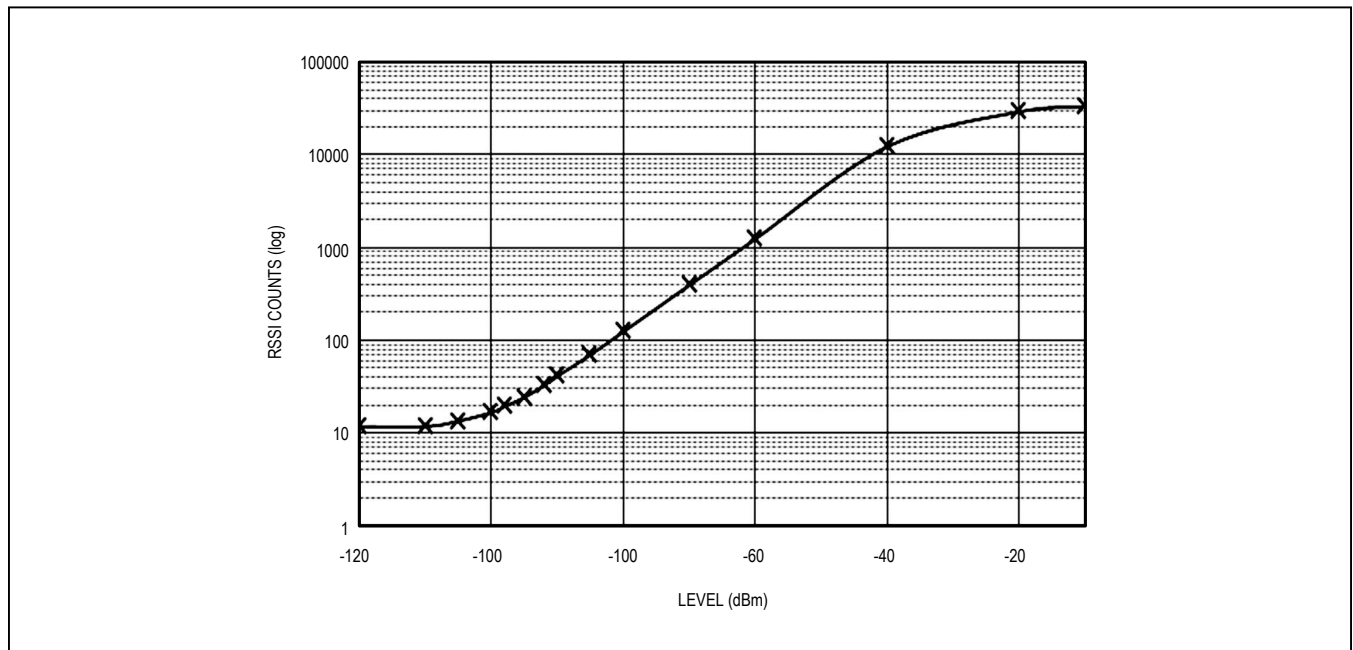

Figure 5. RSSI Mapping from Counts to Signal Level

cfgldx

The `cfgldx` input parameter selects the particular configuration to be used according to the following table. If nothing is entered for this parameter, or any value outside of the range of 1 to 6 inclusive, then the default configuration is FSK, 315MHz, 31.25Kbps.

config_rx_radio [cfgldx]

CFGIDX	CONFIGURATION (MODULATION, CARRIER CENTER FREQ, BIT RATE)
1	FSK, 902MHz, 31.25Kbps
2	FSK, 915MHz, 125Kbps
3	FSK, 315MHz, 31.25Kbps
4	FSK, 434MHz, 31.25Kbps
5	FSK, 928MHz, 125Kbps
6	FSK, 868MHz, 31.25Kbps
Any Other Value or Not Entered	FSK, 315MHz, 31.25Kbps

The `config_rx_radio` command is used to configure the radio for receiving data. For example, to configure a MAX7037 for FSK, 928MHz, 125Kbps operation, one would send the command:

config_rx_radio 5

Refer to the previous table for the decoding of the `cfgldx` input parameter.

agc_thresh thresh

The `agc_thresh` command is used to set the AGC threshold for the receiver. The threshold is set according to the value of the input parameter `thresh`. During the initial phase of packet reception, if AGC is enabled, the MAX7037 compares the magnitude of the envelope of the received signal against the threshold. If the signal level exceeds the threshold, the AGC gain is set to low; otherwise, it is set to high.

thresh

The `thresh` input parameter configures the AGC threshold. It must be a value between 1 and 5. Any value outside of this range, or no value entered at all will result in a default value of 5 being used. A low value of `thresh` corresponds to a low threshold setting. For maximum sensitivity, use a value of 5.

agc_status

The `agc_status` command is used to query the status of the AGC settings. When the firmware receives this command, it will return two values: the enable/disable state, and the threshold setting. See an example of its usage below.

```
>> agc_status
```

```
>> AGC enabled, threshold = 3
```

agc_disable

The `agc_disable` command is used to disable the AGC. The AGC will remain disabled until an `agc_enable` command is issued.

agc_enable

The `agc_enable` command is used to enable the AGC. The AGC will remain enabled until an `agc_disable` command is issued, or the MAX7037 is reset. The firmware disables AGC by default.

goto_deep_sleep

The `goto_deep_sleep` command puts the MAX7037 into DEEP SLEEP mode. The IC will enter deep sleep for a period of time approximately 47 hours. Reset the MAX7037 to return to active operation.

Firmware Download Through SPI

The MAX7037 contains a 64KB flash memory. This is organized into 128 512-byte pages. Following a reset, the MAX7037 executes a bootloader program from a small ROM. Depending on the state of the TEST0 input pin, the MAX7037 will either enter PROGRAMMING mode or RUNTIME mode. In PROGRAMMING mode, the bootloader configures the SPI interface of the MAX7037 and a sequence of messages is transferred over the SPI between the host and the MAX7037 bootloader program. The main purpose is for the host to program the FLASH memory with the firmware code. If the TEST0 pin is such that the MAX7037 enters RUNTIME mode, then it immediately starts executing firmware code from FLASH. This section describes the details of how the host programs the FLASH memory through the SPI.

SPI Configuration

The MAX7037 is configured as an SPI slave and the host will be the SPI master. SPI is an industry standard 4-wire serial interface. The four SPI signals are Chip Select (CS), Master In Slave Out (MISO), Master Out Slave In (MOSI) and the clock signal (SCLK). In Programming mode, the mapping of SPI signals to pins of the MAX7037 is as shown in the following table. The host, being the SPI master, drives CS, SCLK and MOSI. The MAX7037, being the SPI slave, drives only MISO. All SPI signals use 3.3V voltage levels.

SPI SIGNAL	PIN LABEL	PIN NUMBER
CS	SCSEDIO0	33
MISO	RSDADIO3	36
MOSI	WSDADIO2	35
SCLK	SCLKDIO1	34

The SPI Chip Select (CS) is active-low. The SPI is configured as half-duplex, so only MISO or MOSI will be used in any given transaction; not both at the same time. Data is shifted out most significant bit first. The clock polarity is active-low, meaning that the SPI clock is low when idle. For the MAX7037, the clock phase is such that the first bit is sampled on the rising edge of the clock after the CS pin has been asserted, and if bits are read out by the host, MISO transitions on the rising edge of SCLK. For the host, MOSI transitions on the falling edge of SCLK and MISO is sampled on the falling edge of SCLK. The timing relationship between the SPI signals can be seen in [Figure 6](#) which shows an example of a single byte being written to the MAX7037 by the host. [Figure 7](#) shows an example of a byte being read from the MAX7037 by the host. The arrows indicate the sampling instants. The frequency of SCLK should not exceed 2MHz.

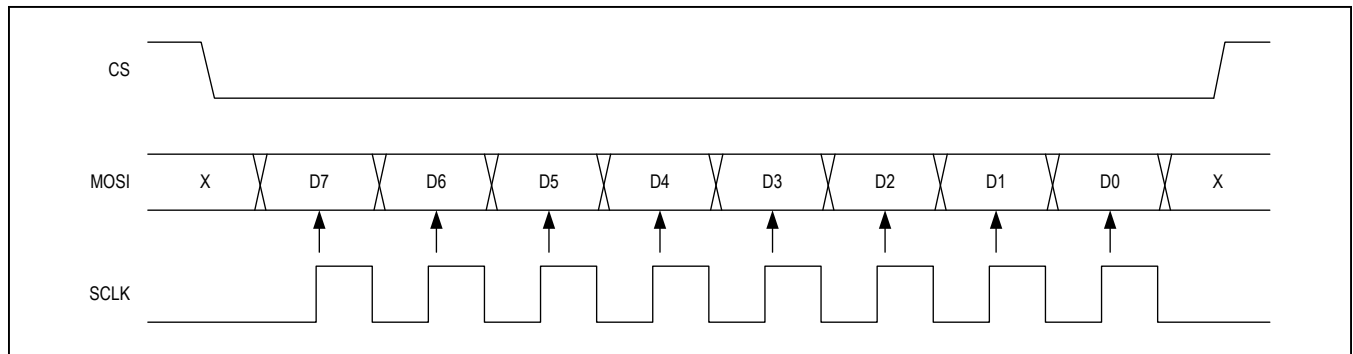

Figure 6. Example of SPI Transaction—Data Sent From Host to MAX7037

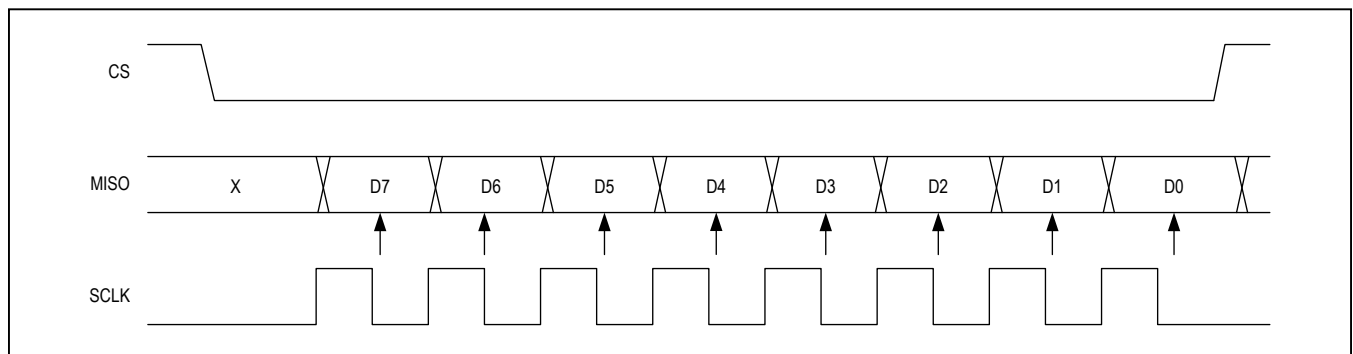

Figure 7. Example of SPI Transaction—Data Sent From MAX7037 to Host

Additional Handshaking Signals

Although the four SPI pins provide the raw means to transfer data between the host and the MAX7037, some additional signals are required to synchronize the handshaking required in the communication protocol. For example, the MAX7037 will require some time to execute a command from the host. To prevent the host from issuing the next command before the MAX7037 is ready for it, the SYNCH signal is provided. As mentioned previously, the host indicates to the MAX7037 whether it should enter Programming or Runtime mode following de-assertion of reset by the TEST0 pin. Finally, the host drives the reset pin. These three signals are shown in the following table.

SIGNAL	PIN LABEL	PIN NUMBER
PGM	TEST0	20
RESET	RESET	1
SYNCH	ADIO7	28

PGM

The use of the PGM signal is shown in the flowchart in [Figure 18](#). After programming the firmware to flash, the host simply reasserts reset and this time, when reset is de-asserted, sets the PGM signal low so the MAX7037 will enter Runtime mode. Note that the TEST0 pin has an internal pulldown resistor.

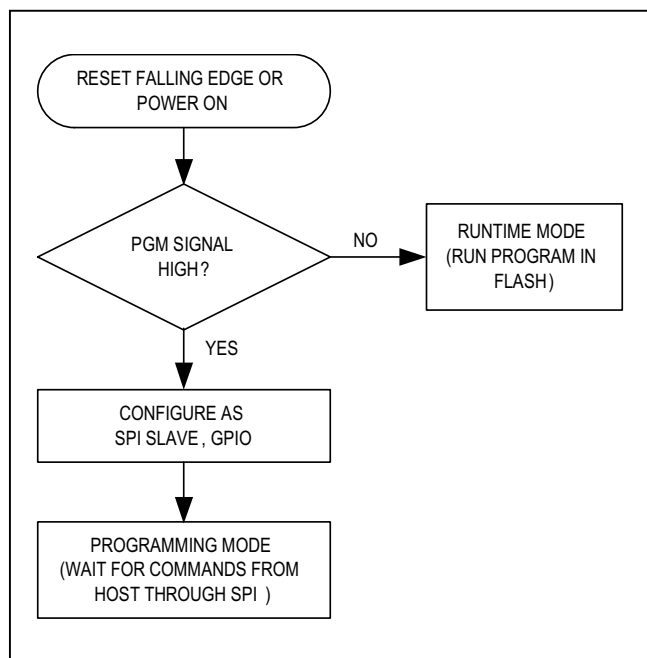

Figure 8. Boot Process

SYNCH

The SYNCH signal provides a means for the MAX7037 to indicate a “busy” status to the host. When the MAX7037 is busy executing some operations, and is not yet ready to receive the next command from the host, it asserts the SYNCH signal low. After sending a command to the MAX7037, the host will see SYNCH go low. It must wait until SYNCH goes high before it issues the next command.

Putting MAX7037 Into Programming Mode

In order to put the MAX7037 into Programming mode, the following sequence of actions should be executed by the host.

- 1) Initialize itself as a SPI master with the SPI configuration described in the [SPI Configuration](#) section.
- 2) Set PGM signal high.
- 3) Set RESET signal high.
- 4) Wait at least 1ms.
- 5) Set RESET signal low.
- 6) Wait at least 1ms.
- 7) Set PGM signal low.
- 8) Wait for SYNCH to go high.
- 9) While the MAX7037 is configuring itself as a SPI slave and so on, it asserts SYNCH low. Once it has fully entered Programming mode and is ready to receive the first command from the host, it asserts SYNCH high.

SPI Transactions

The firmware programming sequence consists of a series of transactions on the SPI bus. All SPI transactions consist of 4-byte transfers. The communication protocol is of the command-response type: the host issues a command to the MAX7037, and the MAX7037 responds with an answer. A command or response consists of at least two 4-byte transfers.

It is important for the synchronization of host MAX7037 communications that the host not assert CS while the MAX7037 is still busy processing the previously received command. An example of an SPI transaction showing a command being sent to the MAX7037 is shown in [Figure 9](#). In this example, the command consists of 8 bytes and so consists of two transactions of 4 bytes each. The first 4 byte segment of the command consists of the hex values: 0xA5, 0x5A, 0xA5, 0x4B. The second 4-byte segment of the command consists of the hex values: 0x00, 0x00, 0x00, 0xF0. The host initially asserts CS after observing that SYNCH is high. It then toggles SCLK and drives the data onto the MOSI line. After de-asserting CS following

the sending of the first four bytes, the host waits to see a de-assertion of SYNCH followed by a re-assertion. Following SYNCH going high, the host asserts CS for the second set of four bytes. After observing SYNCH go low, then high again following the second set of four bytes, the host can then consider the sending of the command completed.

Figure 10 shows an example SPI transaction where the MAX7037 is providing a response to the previously issued command. In this case, the host asserts CS after observing that SYNCH is high. It toggles SCLK and the MAX7037 will start shifting out data on MISO. The host receives the first four bytes which are 0xA5, 0x5A, 0xA5, 0x8C. After receiving the first four bytes, the host de-asserts CS, then waits for SYNCH to go low, then high, after which it asserts CS for the second set of four bytes.

These are 0x04, 0x01, 0x00 and 0x36. Following de-assertion of CS, the MAX7037 brings SYNCH low, then high again. Upon observing this, the host knows that the response has completed. It then processes the received data.

The required sequence of actions of the host to ensure synchronization of the handshaking with the MAX7037 is described by the flow chart in Figure 11. In order to avoid deadlock, the host must be sampling SYNCH often enough to detect the high–low–high transition of SYNCH. The busy state (duration of SYNCH being low) can range from 30µs to 60ms.

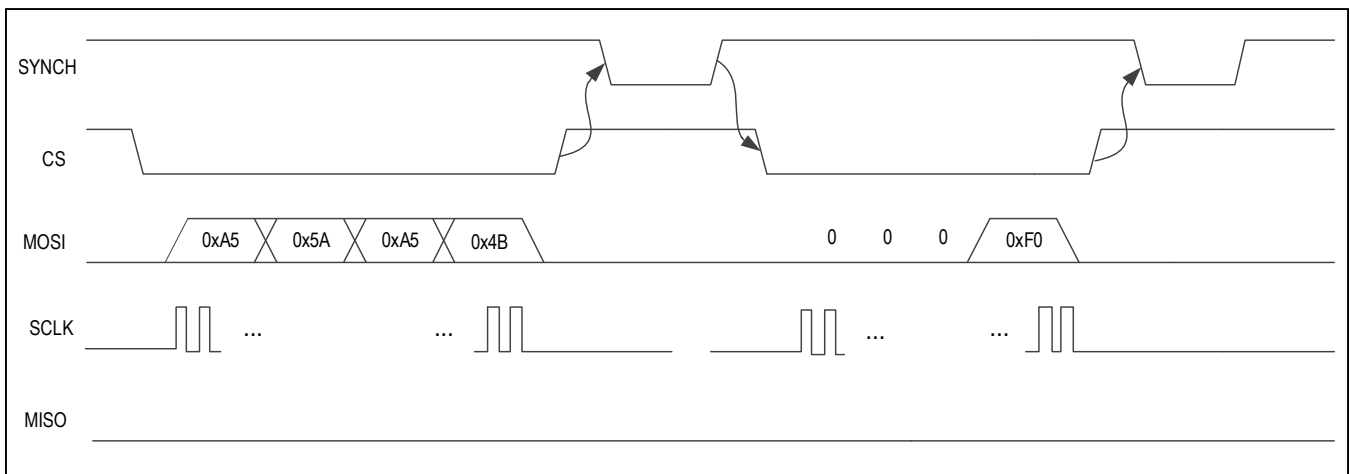

Figure 9. Example SPI Transaction Host ≥ MAX7037

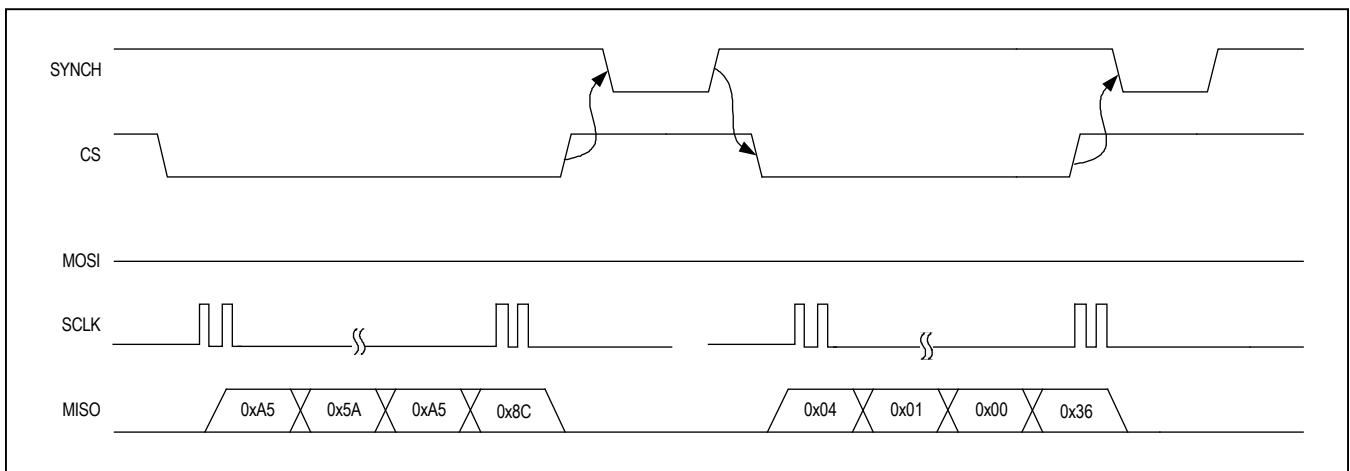

Figure 10. Example SPI Transaction MAX7037 ≥ Host

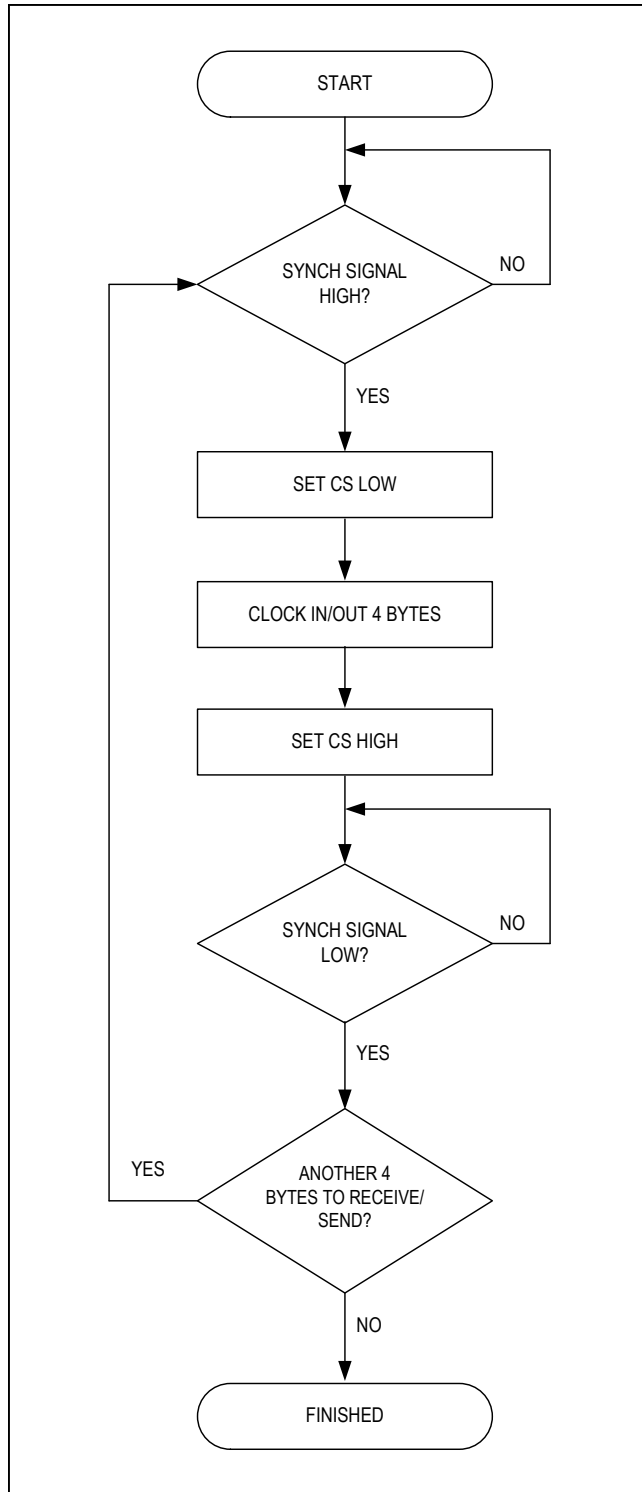

Figure 11: Four-byte Message Transmission/Reception Flow Chart

Firmware Hex File

The firmware is provided as a text file in the Intel HEX format. The version number of the firmware is encoded in the filename. For example, the name of the V1.0 release firmware file is MAX7037_FW_V1.0.hex. Each firmware version has an associated text file which is the release notes for the firmware. The release notes contain critical information on values that need to be transferred over the SPI during firmware download in addition to a description of any new features. The filename of the release notes has the format MAX7037_FW_Vx.y_RELNOTES.txt, where x.y is the release number of the firmware version. For example, the release notes for V1.0 have the filename MAX7037_FW_V1.0_RELNOTES.txt.

The Intel HEX format is an industry standard format and information on it can be found online². It will be assumed the reader is familiar with this format. The first step is for the host to reformat the HEX file into a form it can transfer. This is left to the customer to handle. Typically, one scans through the file considering each record in turn. The data is extracted, along with the address, in flash, where the data is to be written. The checksum for each record should be checked and the file conversion process terminated with an error if a checksum error is detected since a bad checksum on a record indicates a corrupted file. The checksum is such that if one sums all the bytes in the record, including the checksum, the result should be 0, if the checksum is valid.

Recall that the flash is organized into 512-byte pages. An integral number of pages must always be written. One cannot write a fraction of a page. If the total number of data bytes in a firmware build is N, then there will be $\text{floor}(N/512)$ full pages, plus one partially filled page containing $N - 512 \times \text{floor}(N/512)$ bytes. The remainder of this final partially filled page needs to be padded with some value (0xFF is recommended) so that the total number of bytes in the image is $512 \times (\text{floor}(N/512) + 1)$. The release notes will contain information on the total number of data bytes in the image, plus the number of pages required to hold the firmware. After extracting the data from the HEX file, the resulting total byte count and number of pages should be compared against the values in the release notes to confirm they match.

At the end of this data extraction process, the host will have an array in its memory of all the bytes that need to be written to the flash in order of address starting from 0x0000. These bytes will, at some point in the process, be transferred, four at a time, through the SPI, to the MAX7037, where the bootloader will write them to flash.

² E.g., https://en.wikipedia.org/wiki/Intel_HEX contains a good description of the HEX format

Error Detection Code

In order to detect corruption of the firmware image in flash, a 16-bit error detection code is used. This code is written to the last two bytes of the last page of the firmware image. An illustration is given in [Figure 12](#). For example, if a firmware release has 14,645 bytes of data, then this is 28.604 pages. Therefore, 29 pages will be required to hold the complete image. There will be 309 bytes of the 29th page filled with data. The remaining 203 bytes of the 29th page should be padded with 0xFF. Then the top two bytes at addresses 0x1FE and 0x1FF of this 29th page should be overwritten with the error detection code. In other words, the absolute addresses of 0x39FE and 0x39FF in flash (in this example) will contain the error detection code. The error detection code will be provided in the release notes.

Programming Sequence

This section describes the sequence of messages that need to be transferred back and forth between host and MAX7037 during the firmware programming operation. The host is assumed to have generated an array consisting of all the bytes that need to be written to flash, including padding bytes and the error detection code. As discussed, this will be an integral number of 512-byte pages. If at any point in the sequence, the MAX7037 detects an error (possibly due to mis-configuration or mis-programming by the host), it will return a message having contents other than what is expected. This is indicated in the fol-

lowing description by the statement “go to error state.” If this happens, the host should return to the beginning of the sequence, reset the MAX7037, with the PRG signal high, and start the sequence over again. The sequence is assumed to start after the host has put the MAX7037 into Programming mode.

- 1) Send the 2 X 4-byte command: {0xA5, 0x5A, 0xA5, 0x4B, 0x00, 0x00, 0x00, 0xF0}
- 2) Read the 2 X 4-byte response. If it is not {0xA5, 0x5A, 0xA5, 0x8C, 0x04, 0x01, 0x00, 0x36} go to error state, else go to next step
- 3) Send the 2 X 4-byte command: {0xA5, 0x5A, 0xA5, 0x6E, Param1, 0x00, 0x00, Param2}. Param1 and Param2 are firmware version-dependent and so provided in the release notes for the firmware.
- 4) Read the 2 X 4-byte response. If it is not {0xA5, 0x5A, 0xA5, 0x58, 0x00, 0x01, 0x00, 0xFE} go to error state, else go to next step
- 5) Send the data array, 4-bytes at a time until all pages have been sent.
- 6) Read the 2 X 4-byte response. If it is not {0xA5, 0x5A, 0xA5, 0x58, 0x00, 0x01, 0x00, 0xFE} go to error state, else go to next step
- 7) Send the 2 X 4-byte command: {0xA5, 0x5A, 0xA5, 0x6C, Param3, 0x00, Param4, Param5}. Param3, Param4 and Param5 are firmware version-dependent and so provided in the release notes for the firmware.
- 8) Read the 2 X 4-byte response. If it is not {0xA5, 0x5A, 0xA5, 0x58, 0x00, 0x01, 0x00, 0xFE} go to error state, else go to next step
- 9) Send the 2 X 4-byte command: {0xA5, 0x5A, 0xA5, 0x71, 0x00, 0x00, 0x00, 0x16}
- 10) Read the 2 X 4-byte response. If it is not {0xA5, 0x5A, 0xA5, 0x58, 0x00, 0x01, 0x00, 0xFE} go to error state, else go to next step
- 11) Assert RESET for 1 ms with PGM low to reset MAX7037 and put into Runtime mode. Release control of the SPI bus.

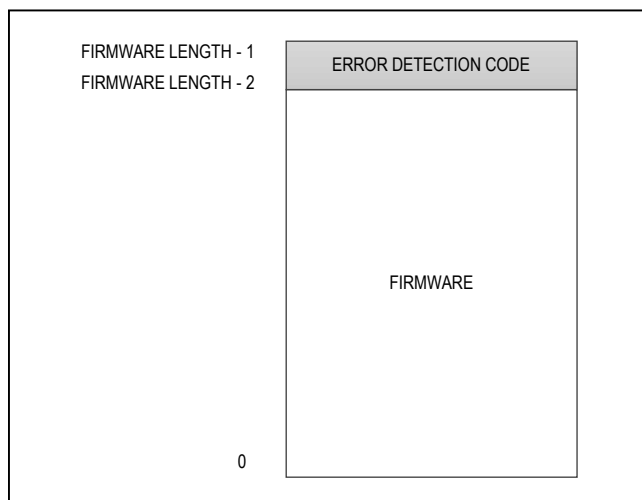

Figure 12. FLASH Error Detection Code

Typical Application Circuit

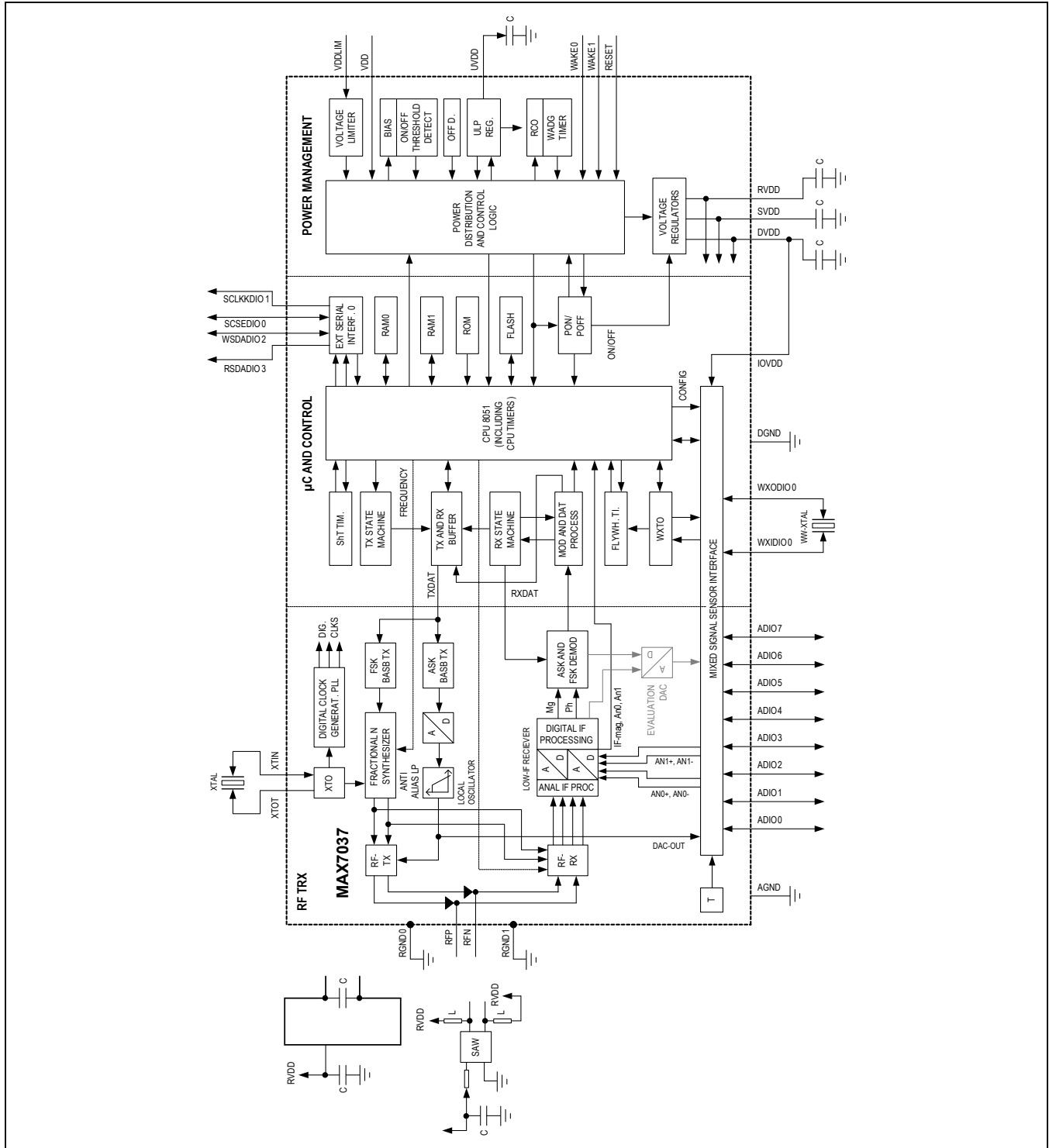

Figure 13: Typical Application Circuit

Ordering Information

PART	TEMP RANGE	PIN-PACKAGE
MAX7037EGL+	-40°C to +85°C	40 TQFN
MAX7037EGL+T	-40°C to +85°C	40 TQFN

+Denotes a lead(Pb)-free/RoHS-compliant package.
T = Tape and reel.

Package Information

For the latest package outline information and land patterns (footprints), go to www.maximintegrated.com/packages. Note that a "+", "#", or "-" in the package code indicates RoHS status only. Package drawings may show a different suffix character, but the drawing pertains to the package regardless of RoHS status.

PACKAGE TYPE	PACKAGE CODE	OUTLINE NO.	LAND PATTERN NO.
TQFN	G4066N-1	21-0635	90-0367

Revision History

REVISION NUMBER	REVISION DATE	DESCRIPTION	PAGES CHANGED
0	9/16	Initial release	—

For pricing, delivery, and ordering information, please contact Maxim Direct at 1-888-629-4642, or visit Maxim Integrated's website at www.maximintegrated.com.

Maxim Integrated cannot assume responsibility for use of any circuitry other than circuitry entirely embodied in a Maxim Integrated product. No circuit patent licenses are implied. Maxim Integrated reserves the right to change the circuitry and specifications without notice at any time. The parametric values (min and max limits) shown in the Electrical Characteristics table are guaranteed. Other parametric values quoted in this data sheet are provided for guidance.

Looking for pricing, stock, or lifecycle information?

Click below to explore more details on WIN SOURCE:

 [View MAX7037EGL+ on WIN SOURCE](#)

 [Maxim Integrated](#) Information

Optimize Your Supply Chain with WIN SOURCE Solutions

-  Global Sourcing Solution
-  Obsolete Management
-  Cost Control Management
-  Shortage Management
-  Alternative Solution
-  Excess Inventory Management