



**THE DATASHEET OF
MASW-011055-TR0500**



Switch, SP2T 100 W Reflective

0.03 - 3.0 GHz



MASW-011055

Rev. V3

Features

- Suitable for High Power Military and Civilian Radio Applications
- Power Handling: 100 W @ 85°C
- Insertion Loss: 0.35 dB @ 2 GHz
- Isolation: 51 dB @ 2 GHz
- Lead-Free 5 mm HQFN-12LD Package
- RoHS* Compliant

Applications

- ISM / MM

Description

The MASW-011055 is a high power PIN diode SP2T switch in a common anode configuration, operating from 30 MHz to 3 GHz. It features low insertion loss and excellent linearity. This device is capable of handling 100 Watts CW incident power at a base plate temperature of 85°C.

This high power switch is ideal for use on land mobile radio and MIL-COM applications that require higher CW and pulsed power operation.

The MASW-011055 is manufactured using MACOM's hybrid manufacturing process featuring high voltage PIN diodes and passive devices integrated in a 5 mm HQFN 12-lead plastic package.

Ordering Information¹

Part Number	Package
MASW-011055-TR0500	500 piece reel
MASW-011055-SMB	Sample Board 0.5 - 3 GHz

1. Reference Application Note M513 for reel size information.

Functional Schematic

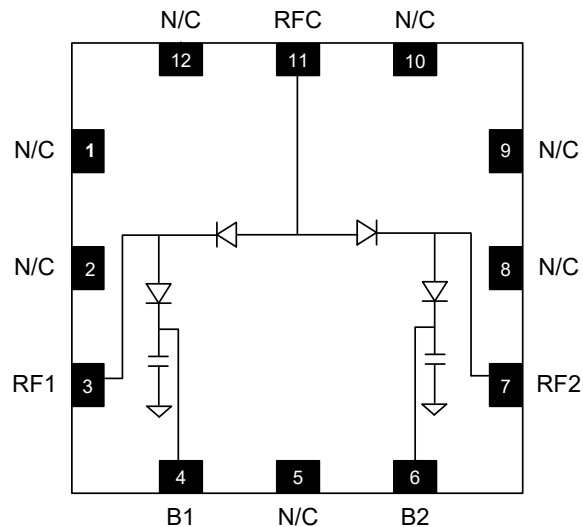

Pin Configuration

Pin #	Function
1, 2, 5, 8, 9, 10, 12	No Connection
3	RF1 / V1 Bias
4	B1 Bias
6	B2 Bias
7	RF2 / V2 Bias
11	RFC / V3 Bias
Paddle ²	Ground

2. The exposed pad centered on the package bottom must be connected to RF, DC and thermal ground.

* Restrictions on Hazardous Substances, compliant to current RoHS EU directive.

Switch, SP2T 100 W Reflective

0.03 - 3.0 GHz



MASW-011055

Rev. V3

Electrical Specifications: $T_A = 25^\circ\text{C}$, Bias³ = +5 / 0 V, 50 mA / 100 mA

Parameter	Test Conditions	Units	Min.	Typ.	Max.
Insertion Loss $P_{IN} = 0$ dBm	0.5 GHz 1 GHz 2 GHz	dB	—	0.10 0.20 0.35	— 0.50 —
Isolation $P_{IN} = 0$ dBm	0.5 GHz 1 GHz 2 GHz	dB	— 48 —	52 54 51	—
Input Return Loss	$P_{IN} = 0$ dBm	dB	—	>15	—
CW Input Power	25°C base plate, 2 GHz	dBm W	—	52 158	—
CW Input Power	85°C base plate, 2 GHz	dBm W	—	50 100	—
P0.1dB	25°C base plate, 2 GHz	dBm	—	>52	—
Input IP3	F1 = 2000 MHz, F2 = 2010 MHz $P_{IN} = 40$ dBm/Tone, 28 V	dBm	—	66	—
RF Switching Speed	(10-90% RF Voltage) 1 MHz Rep Rate in Modulating Mode	ns	—	500	—

3. See Bias table.

Bias (+5 V / 0 V for Small Signal Testing)⁴

RF State	V1 Bias (V)	V2 Bias (V)	V3 Bias (V)	B1 Bias (V)	B2 Bias (V)
RFC – RF1 Low Loss RFC – RF2 Isolation	0 V @ -100 mA	+5 V @ 50 mA	+5 V @ 100 mA	+5 V @ 0 mA	0 V @ -50 mA
RFC – RF2 Low Loss RFC – RF1 Isolation	+5 V @ 50 mA	0 V @ -100 mA	+5 V @ 100 mA	0 V @ -50 mA	+5 V @ 0 mA

4. DC reverse bias of a PIN Diode operating at a high power is dependent on RF frequency, incident power, and VSWR. See Minimum Reverse DC Voltage table for high power operation.

Switch, SP2T 100 W Reflective 0.03 - 3.0 GHz



MASW-011055

Rev. V3

Minimum Reverse DC Voltage⁵

Frequency (MHz)	Minimum Reverse DC Voltage
30	120 V
100	119 V
200	114 V
300	106 V
500	90 V
1000	59 V
1500	43 V
2000	33 V

5. Required to maintain low loss under 100 W of incident power with 1.5:1 VSWR.

Application Schematic

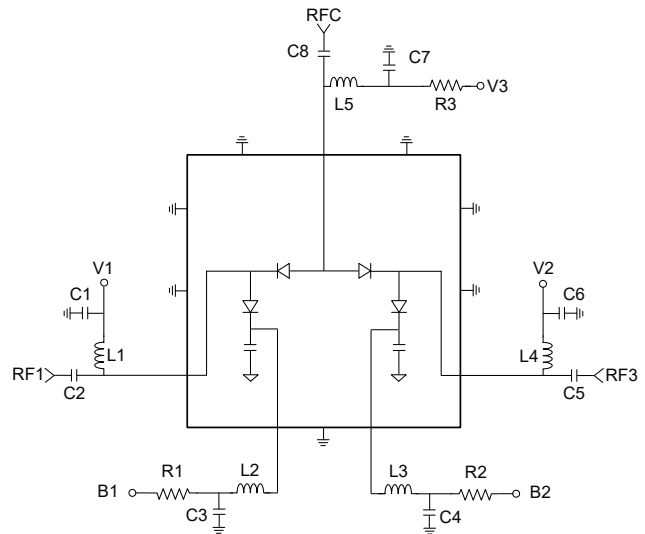

Absolute Maximum Ratings^{6,7}

Parameter	Absolute Maximum
Forward Current	200 mA
Reverse DC Voltage	150 V
Operating Temperature	-40°C to +85°C
Storage Temperature	-55°C to +150°C
Junction Temperature	+175°C

6. Exceeding any one or combination of these limits may cause permanent damage to this device.
7. MACOM does not recommend sustained operation near these survivability limits.

Off-Chip Component Values

Component	Operating Frequency		Size
	0.03 - 1.0 GHz	0.5 - 3.0 GHz	
C1, C3, C4, C6, C7, C8	0.1 μ F	270 pF	0603
C2, C5, C8	0.1 μ F	27 pF	0603
L1 - L5	3.3 μ H	82 nH	0603
R1 - R2 ⁸	82 Ω	82 Ω	1210
R3 ⁸	39 Ω	39 Ω	1210

8. Resistance values are used for small signal testing under +5 V / 0 V bias conditions.

MASW-011055 with MADR-010574 Driver Application Schematic⁹

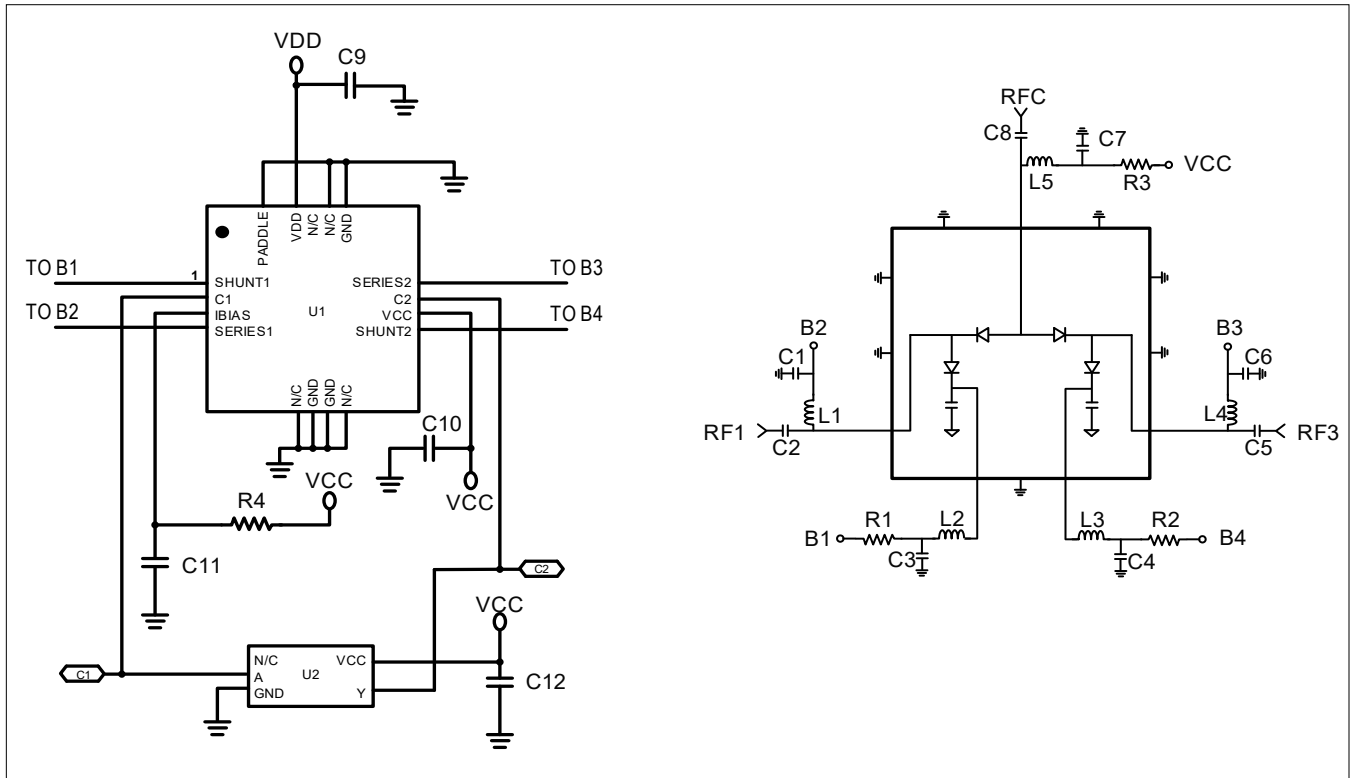

9. See page 3 for R3, L1 - L5 and C1 - C8 values.

Parts List

Part	Value
C9	0.01 μ F
C10 - C12	0.1 μ F
R1, R2 ¹⁰	12 k Ω
R4	499 k Ω
U2	SN74AHC1G

10. Resistor values calculated to provide ~10 mA of shunt diode bias current given $V_{CC} = 5$ V and $V_{DD} = 120$ V.

Handling Procedures

Please observe the following precautions to avoid damage:

Static Sensitivity

Silicon Integrated Circuits are sensitive to electrostatic discharge (ESD) and can be damaged by static electricity. Proper ESD control techniques should be used when handling these Class 1B HBM devices.

Switch, SP2T 100 W Reflective 0.03 - 3.0 GHz



MASW-011055

Rev. V3

Typical Performance Curves @ +25°C (using external bias tees):

Insertion Loss

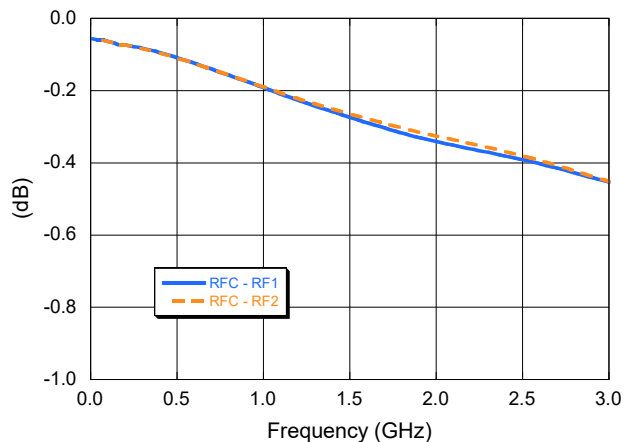

Isolation

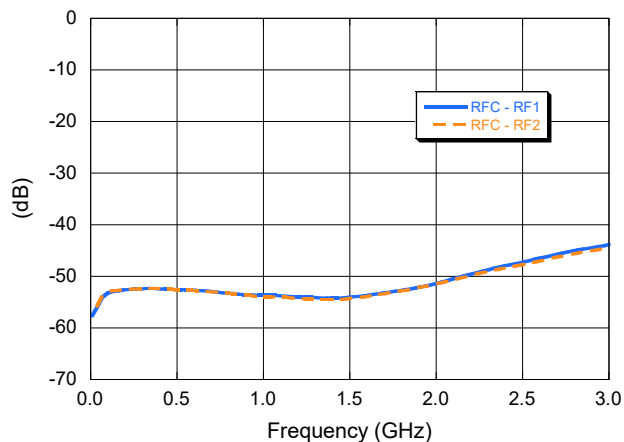

Input Return Loss

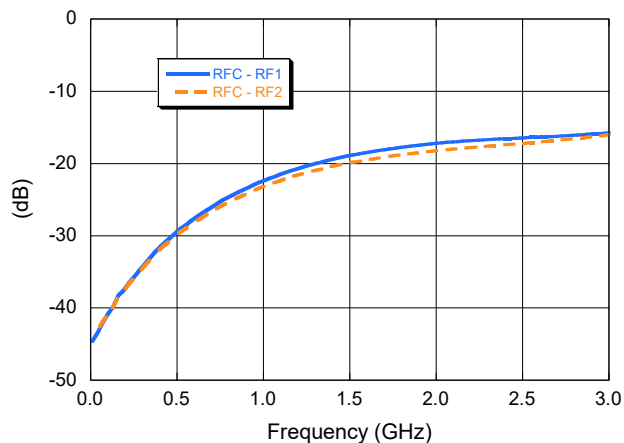

Output Return Loss

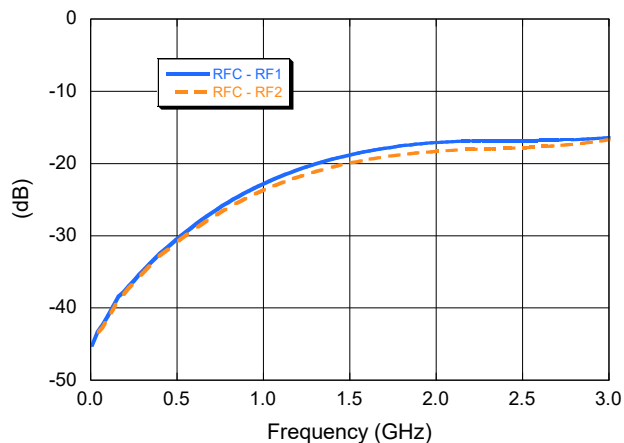

Switch, SP2T 100 W Reflective 0.03 - 3.0 GHz



MASW-011055
Rev. V3

Lead Free 5 mm 12-Lead HQFN †

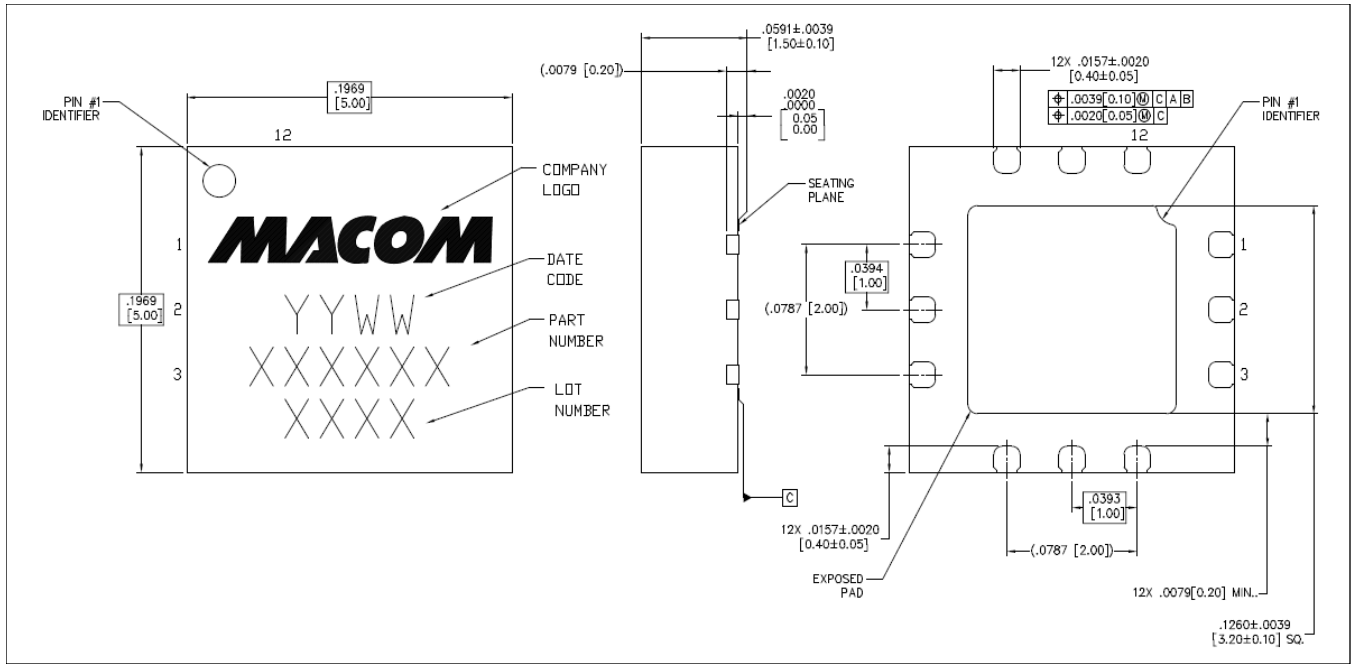

† Reference Application Note S2083 for lead-free solder reflow recommendations.
Meets JEDEC moisture sensitivity level 1 requirements.
Plating is NiPdAuAg.

Switch, SP2T 100 W Reflective 0.03 - 3.0 GHz



MASW-011055

Rev. V3

MACOM Technology Solutions Inc. ("MACOM"). All rights reserved.

These materials are provided in connection with MACOM's products as a service to its customers and may be used for informational purposes only. Except as provided in its Terms and Conditions of Sale or any separate agreement, MACOM assumes no liability or responsibility whatsoever, including for (i) errors or omissions in these materials; (ii) failure to update these materials; or (iii) conflicts or incompatibilities arising from future changes to specifications and product descriptions, which MACOM may make at any time, without notice. These materials grant no license, express or implied, to any intellectual property rights.

THESE MATERIALS ARE PROVIDED "AS IS" WITH NO WARRANTY OR LIABILITY, EXPRESS OR IMPLIED, RELATING TO SALE AND/OR USE OF MACOM PRODUCTS INCLUDING FITNESS FOR A PARTICULAR PURPOSE, MERCHANTABILITY, INFRINGEMENT OF INTELLECTUAL PROPERTY RIGHT, ACCURACY OR COMPLETENESS, OR SPECIAL, INDIRECT, INCIDENTAL, OR CONSEQUENTIAL DAMAGES WHICH MAY RESULT FROM USE OF THESE MATERIALS.

MACOM products are not intended for use in medical, lifesaving or life sustaining applications. MACOM customers using or selling MACOM products for use in such applications do so at their own risk and agree to fully indemnify MACOM for any damages resulting from such improper use or sale.

Looking for pricing, stock, or lifecycle information?

Click below to explore more details on WIN SOURCE:

- ⊖ [View MASW-011055-TR0500 on WIN SOURCE](#)
- ⊖ [M/A-Com Technology Solutions Information](#)

Optimize Your Supply Chain with WIN SOURCE Solutions

- ✓ Global Sourcing Solution
- ✓ Obsolete Management
- ✓ Cost Control Management
- ✓ Shortage Management
- ✓ Alternative Solution
- ✓ Excess Inventory Management