



**THE DATASHEET OF  
MAAM-011229-TR1000**



# Broadband Low Noise Amplifier

## 0.05 - 4 GHz



MAAM-011229

Rev. V3

### Features

- 19 dB flat Broadband Gain to 3.25 GHz
- Low Noise Figure:
  - 1.3 dB @ 1.2 GHz
  - 1.8 dB @ 3.25 GHz
- High Linearity OIP3:
  - 36 dBm @ 1.2 GHz
  - 33 dBm @ 3.25 GHz
- Internal Matching to 50  $\Omega$
- Single Voltage Bias: 3 - 5 V
- Integrated Active Bias Circuit
- Current Adjustable 20 - 120 mA
- Lead-Free 2 mm 8-Lead PDFN Package
- RoHS\* Compliant

### Applications

- CATV, Broadcast, ISM/MM

### Description

The MAAM-011229 is a broadband high dynamic range, single stage MMIC LNA assembled in a lead-free 2 mm 8 Lead PDFN plastic package. The amplifier is internally matched to provide flat gain and excellent return losses to 3.25 GHz without any external matching components. Use of external matching could extend usable frequency range beyond 4 GHz.

This low noise amplifier has an integrated active bias circuit allowing direct connection to 3 V or 5 V bias and minimizing variations over temperature and process. The bias current can be adjusted with an optional external resistor, so the user can customize the power consumption to fit the application.  $I_{ADJ}$  pin can be utilized as an enable pin to power the device up and down during operation.

### Functional Block Diagram

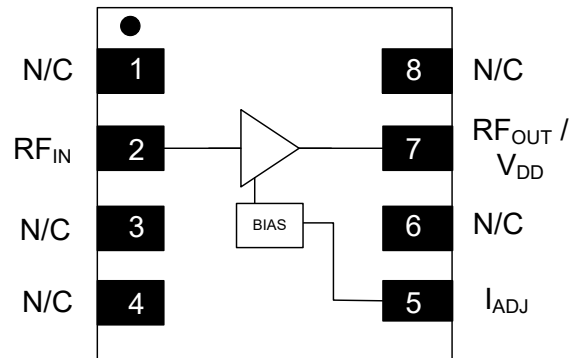

### Pin Configuration<sup>3</sup>

Pin #	Pin Name	Description
1, 3, 4, 6, 8	N/C	No Connection
2	RF <sub>IN</sub>	RF Input
5	$I_{ADJ}$	Bias Current Adjust
7	RF <sub>OUT</sub> / V <sub>DD</sub>	RF Output / Drain Voltage
9	Pad <sup>4</sup>	Ground

3. MACOM recommends connecting all No Connection (N/C) pins to ground.

4. The exposed pad centered on the package bottom must be connected to RF, DC and thermal ground.

### Ordering Information<sup>1,2</sup>

Part Number	Package
MAAM-011229-TR1000	1000 piece reel
MAAM-011229-TR3000	3000 piece reel
MAAM-011229-SMB	Sample Board

1. Reference Application Note M513 for reel size information.

2. All sample boards include 5 loose parts.

1 \* Restrictions on Hazardous Substances, compliant to current RoHS EU directive.

# Broadband Low Noise Amplifier

## 0.05 - 4 GHz



MAAM-011229

Rev. V3

### Electrical Specifications: $V_{DD} = 5\text{ V}$ , $+25^{\circ}\text{C}$ , $Z_0 = 50\ \Omega$ , Typical Application Circuit

Parameter	Test Conditions	Units	Min.	Typ.	Max.
Gain	0.05 - 3.25 GHz 4 GHz	dB	17 —	19 18	—
Noise Figure	0.05 - 1.2 GHz 1.2 - 3.25 GHz 4 GHz	dB	—	1.3 1.6 2.1	— 2.2 —
Input Return Loss	0.05 - 3.25 GHz	dB	—	16	—
Output Return Loss	0.05 - 3.25 GHz	dB	—	14	—
Output IP3	$P_{IN} = -15\text{ dBm}$ per tone, 6 MHz spacing 0.05 - 1.2 GHz 1.2 - 3.25 GHz	dBm	—	36 33	—
Output IP2	$P_{IN} = -15\text{ dBm}$ per tone, 6 MHz spacing 0.05 - 1.2 GHz 1.2 - 3.25 GHz	dBm	—	45 36	—
Output P1dB	0.05 - 1.2 GHz 1.2 - 3.25 GHz	dBm	—	19.5 18.5	—
Current	$I_{DD}$	mA	—	80	115

### Maximum Operating Conditions

Parameter	Absolute Maximum
RF Input Power CW	4 dBm
$V_{DD}$	7 V
Operating Temperature <sup>5</sup>	-40°C to +85°C
Junction Temperature <sup>6</sup>	+150°C

- Operating at nominal conditions with  $T_J \leq 150^{\circ}\text{C}$  will ensure  $\text{MTTF} > 1 \times 10^6$  hours.
- Junction Temperature ( $T_J$ ) =  $T_C + \Theta_{JC} * ((V * I) - (P_{OUT} - P_{IN}))$   
Typical thermal resistance ( $\Theta_{JC}$ ) = 85°C/W
  - For  $T_C = +25^{\circ}\text{C}$ ,  
 $T_J = 59^{\circ}\text{C}$  @ 5 V, 80 mA
  - For  $T_C = +85^{\circ}\text{C}$ ,  
 $T_J = 119^{\circ}\text{C}$  @ 5 V, 80 mA

### Absolute Maximum Ratings<sup>7,8</sup>

Parameter	Absolute Maximum
RF Input Power CW	30 dBm
$V_{DD}$	8 V
Storage Temperature	-55°C to +150°C
Junction Temperature <sup>6</sup>	+175°C

- Exceeding any one or combination of these limits may cause permanent damage to this device.
- MACOM does not recommend sustained operation near these survivability limits.

### Handling Procedures

Please observe the following precautions to avoid damage:

### Static Sensitivity

Gallium Arsenide Integrated Circuits are sensitive to electrostatic discharge (ESD) and can be damaged by static electricity. Proper ESD control techniques should be used when handling these devices.

# Broadband Low Noise Amplifier

## 0.05 - 4 GHz



MAAM-011229

Rev. V3

### Typical Application Circuit

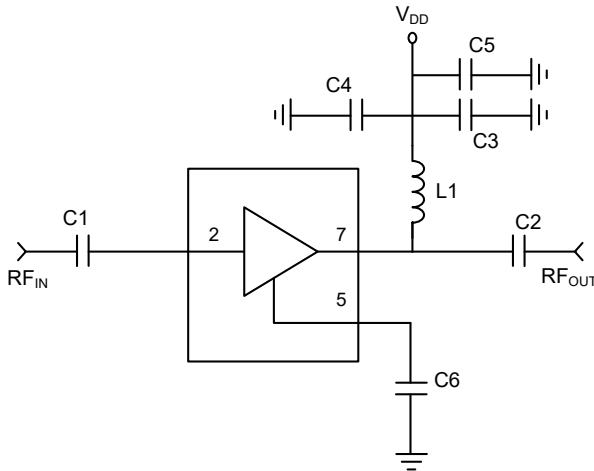

### Typical Parts List, $V_{DD} = 5\text{ V} \& 3\text{ V}$

Component	Value	Package
C1 - C3, C6	1000 pF	0402
C4	0.1 $\mu\text{F}$	0402
C5	47 pF	0402
L1	Ferrite Bead <sup>9</sup>	0402

9. Murata, part number BLM15HD182SN.

### Current Adjust Options<sup>10</sup>

The  $I_{ADJ}$  (pin 5) of MAAM-011229 may be used to adjust the DC operating current by placing either R1 or R2 as shown the schematic below. Placing resistor R2 to ground will reduce the current from typical application level. When using R2 to reduce current do not place (DNP) R1. To increase current from typical application circuit install resistor R1 and connect to  $V_{DD}$ .

The table below shows values of R1 and R2 for a range of operating currents for  $V_{DD} = 5\text{ V}$  and  $3\text{ V}$ .

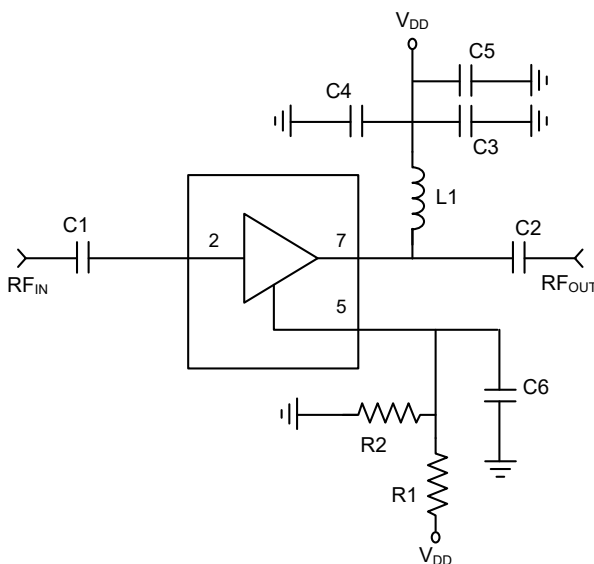

I (mA)	$V_{DD} = 5\text{ V}$		$V_{DD} = 3\text{ V}$	
	R1	R2	R1	R2
20	DNP	820 $\Omega$	DNP	2.0 k $\Omega$
40	DNP	1.2 k $\Omega$	DNP	4.7 k $\Omega$
60	DNP	2.7 k $\Omega$	Typical application without R1 and R2	
80	Typical application without R1 and R2		5.0 k $\Omega$	DNP
100	12 k $\Omega$	DNP	2.4 k $\Omega$	DNP
120	5 k $\Omega$	DNP	not recommended	

10. Some lot to lot variation in current may be observed, requiring a small adjustment in resistor value for a target current. Operation below 20 mA can result in lower gain.

# Broadband Low Noise Amplifier

## 0.05 - 4 GHz



MAAM-011229

Rev. V3

### Typical Performance Curves @ 5 V / 80 mA, $Z_0 = 50 \Omega$

**Gain to 4 GHz**

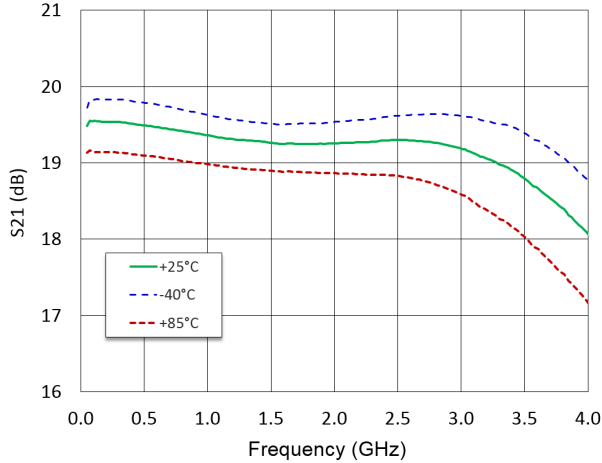

**Gain to 8 GHz**

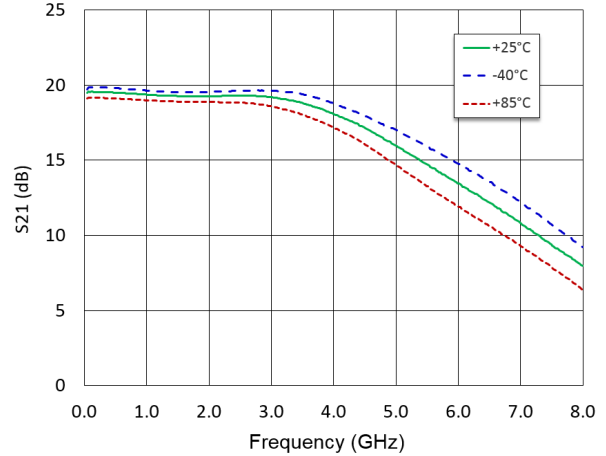

**Input Return Loss**

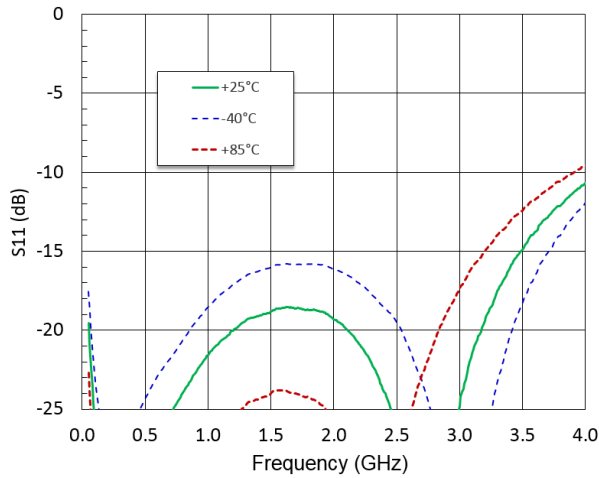

**Output Return Loss**

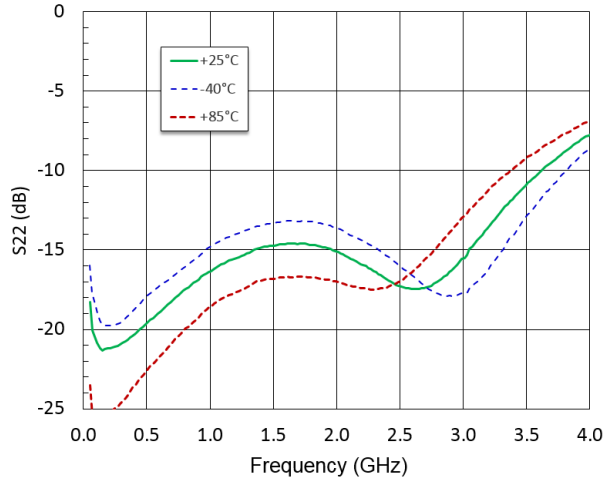

**Noise Figure**

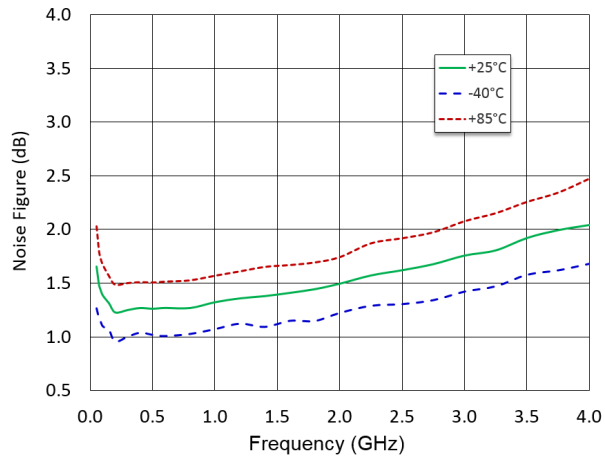

**Reverse Isolation**

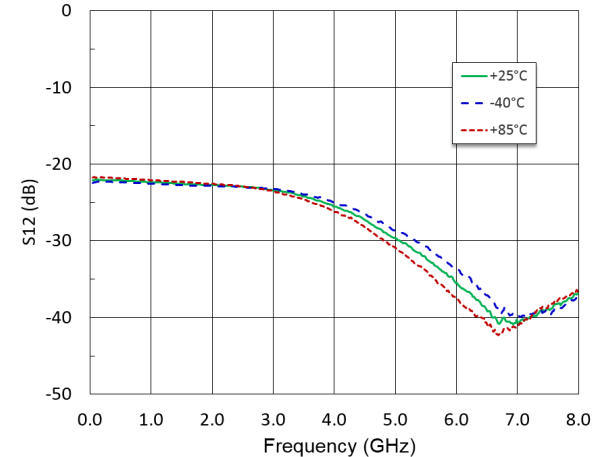

# Broadband Low Noise Amplifier

## 0.05 - 4 GHz



MAAM-011229

Rev. V3

### Typical Performance Curves @ 5 V / 80 mA , $Z_0 = 50 \Omega$

**OIP3**

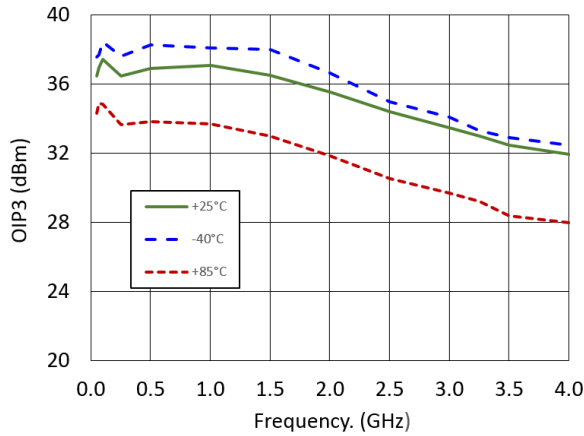

**OIP2**

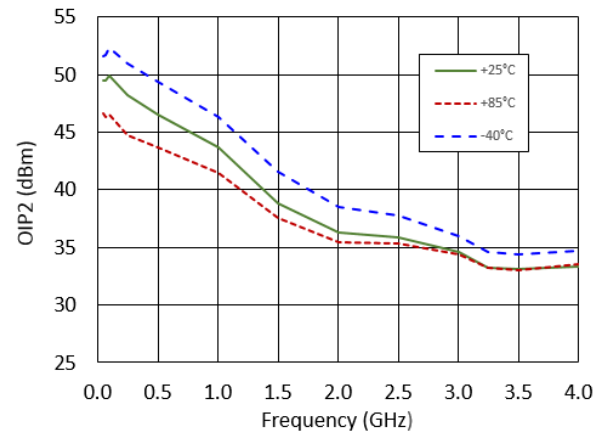

**P1dB**

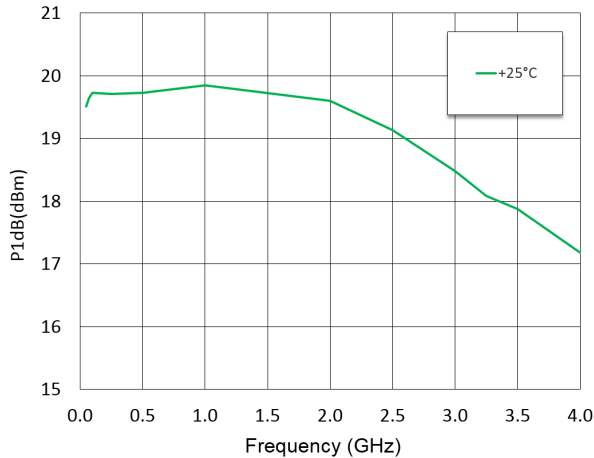

**P1dB vs. Current, +25°C**

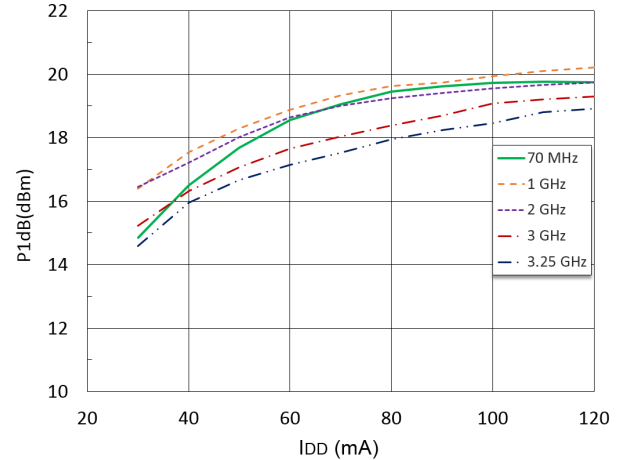

**Noise Figure vs. Current, +25°C**

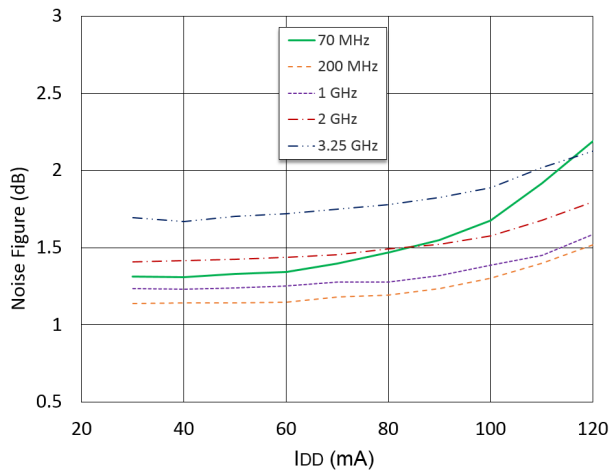

**OIP3 vs. Current, +25°C**

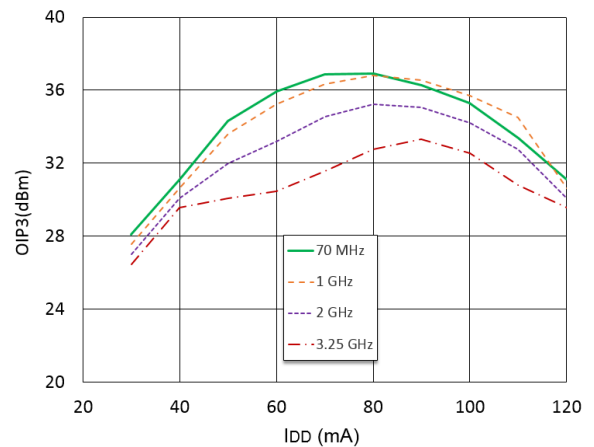

# Broadband Low Noise Amplifier

## 0.05 - 4 GHz



MAAM-011229

Rev. V3

### Electrical Specifications: $V_{DD} = 3\text{ V}$ , $+25^{\circ}\text{C}$ , $Z_0 = 50\ \Omega$ , Typical Application Circuit

Parameter	Test Conditions	Units	Min.	Typ.	Max.
Gain	0.05 - 3.25 GHz 4 GHz	dB	—	19 18	—
Noise Figure	0.05 - 1.2 GHz 1.2 - 3.25 GHz 4 GHz	dB	—	1.3 1.6 2.1	—
Input Return Loss	0.05 - 3.25 GHz	dB	—	16	—
Output Return Loss	0.05 - 3.25 GHz	dB	—	14	—
Output IP3	$P_{IN} = -15\text{ dBm}$ per tone, 6 MHz spacing 0.05 - 1.2 GHz 1.2 - 3.25 GHz	dBm	—	33 40	—
Output IP2	$P_{IN} = -15\text{ dBm}$ per tone, 6 MHz spacing 0.05 - 1.2 GHz 1.2 - 3.25 GHz	dBm	—	43 37	—
Output P1dB	0.05 - 1.2 GHz 1.2 - 3.25 GHz	dBm	—	17.0 15.5	—
Current	$I_{DD}$	mA	—	60	—

### Typical Performance Curves @ 3 V / 60 mA, $Z_0 = 50 \Omega$

**Gain to 4 GHz**

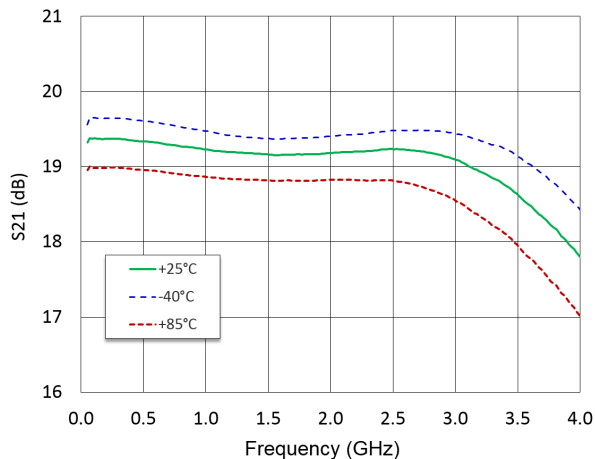

**Gain to 8 GHz**

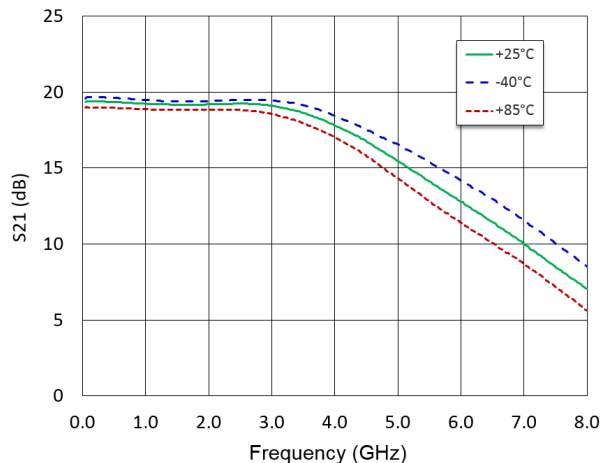

**Input Return Loss**

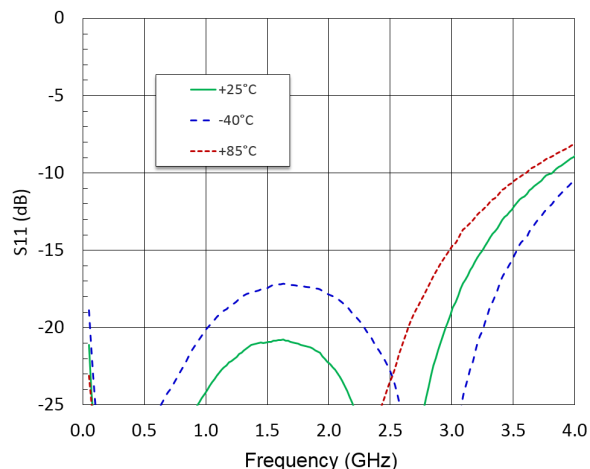

**Output Return Loss**

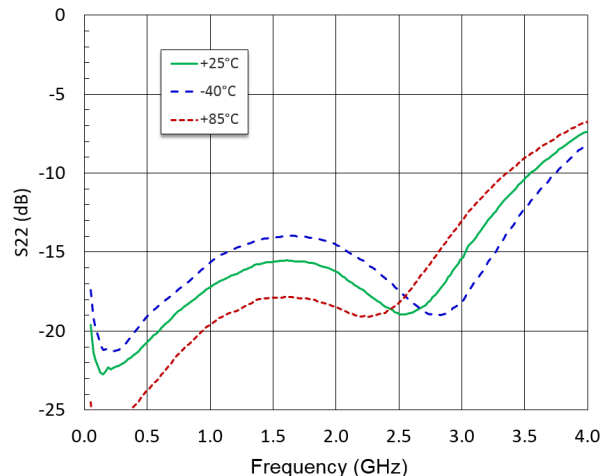

**Noise Figure**

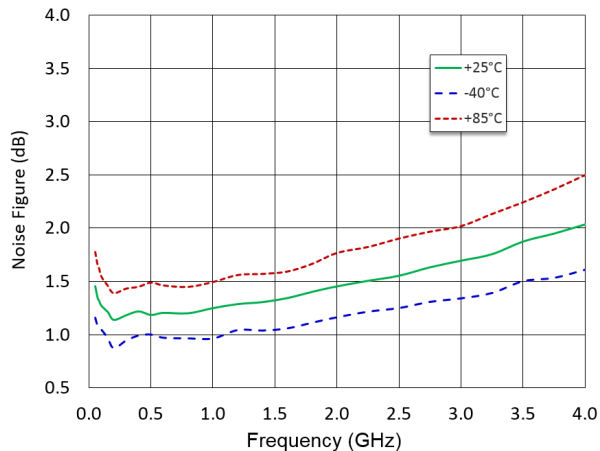

**Reverse Isolation**

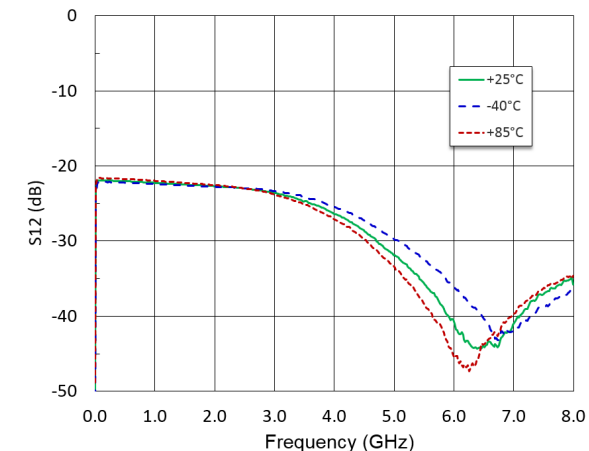

### Typical Performance Curves @ 3 V / 60 mA, $Z_0 = 50 \Omega$

**OIP3**

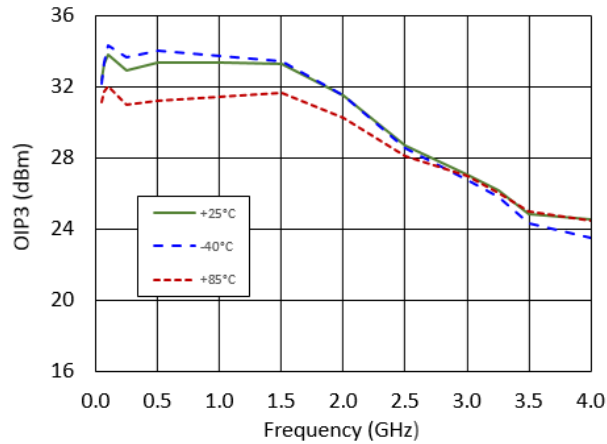

**OIP2**

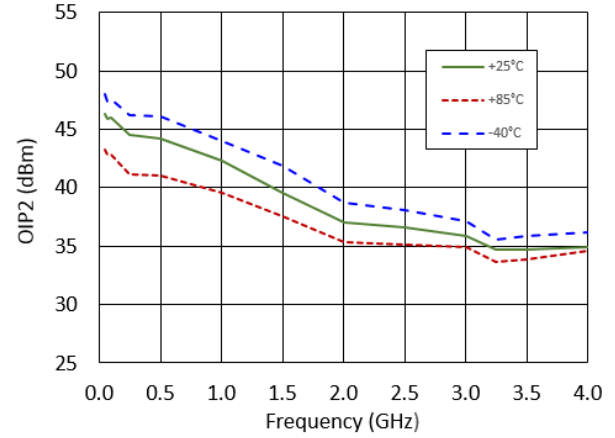

**P1dB vs. Frequency**

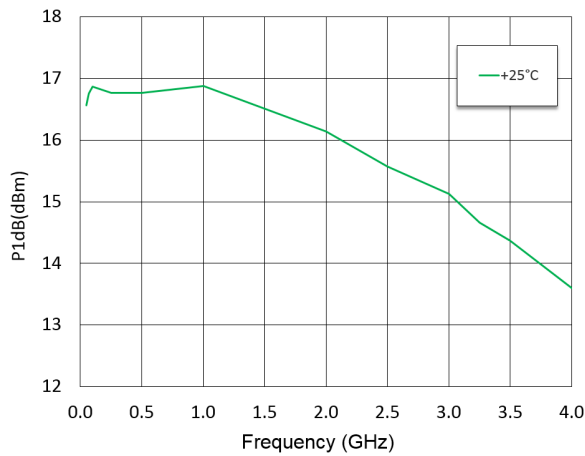

**P1dB vs. Current, +25°C**

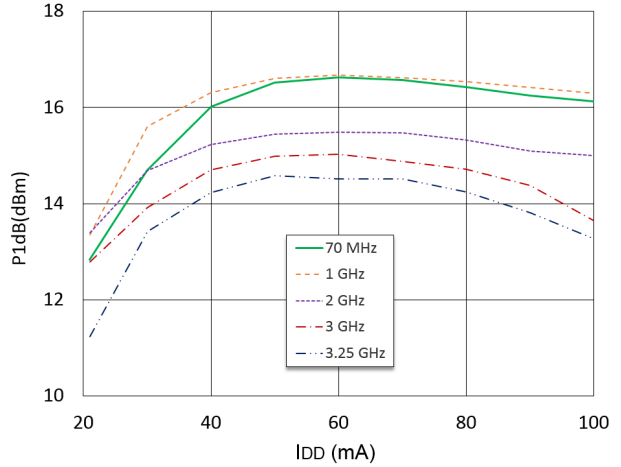

**Noise Figure vs. Current, +25°C**

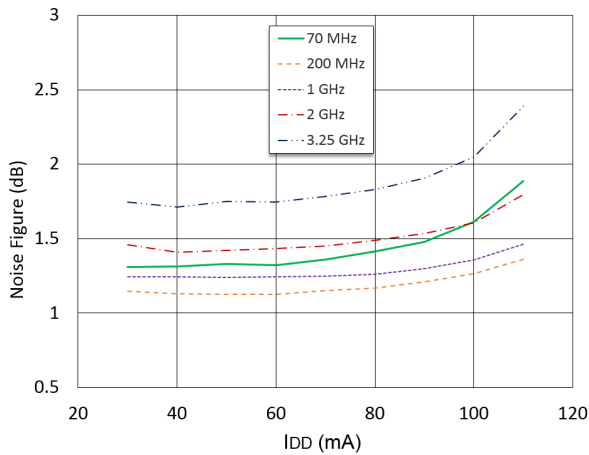

**OIP3 vs Current, +25°C**

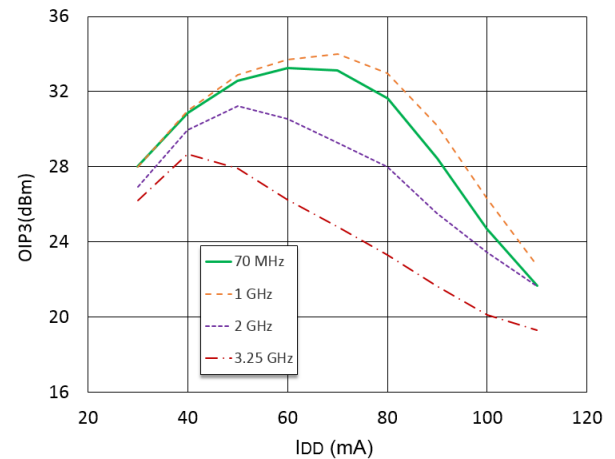

# Broadband Low Noise Amplifier

## 0.05 - 4 GHz



MAAM-011229

Rev. V3

### Recommended PCB Layout

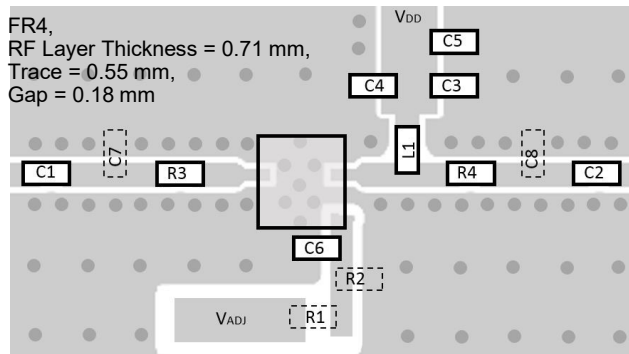

The recommended PCB layout includes place holders for additional components that are not necessary for typical applications but may be useful for extending performance to higher frequencies or optimizing a particular performance parameter at different bias conditions.

### Sample Board Parts List

Component	Value	Package
C1 - C3, C6	1000 pF	0402
C4	0.1 $\mu$ F	0402
C5	47 pF	0402
C7, C8	DNP	0402
R3, R4	0 $\Omega$	0402
R1, R2	DNP	0402
R3, R4	0 $\Omega$	0402
L1	Ferrite Bead <sup>10</sup>	0402

10. Murata, part number BLM15HD182SN.

### Sample Board Schematic

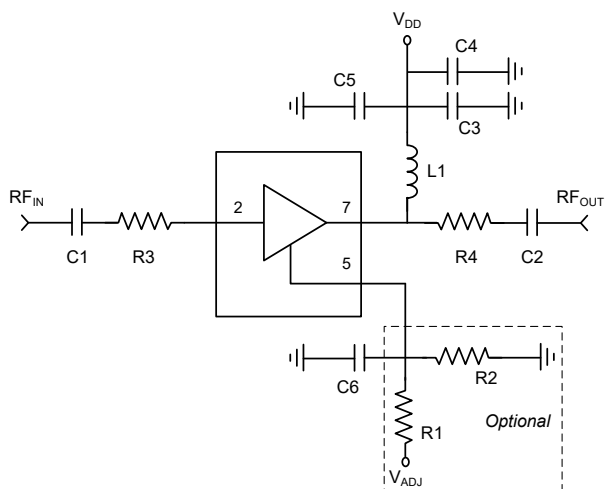

### PCB Land Pattern

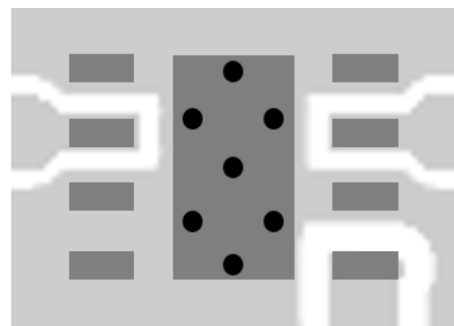

### Applications Section: Power Down Option

The  $I_{ADJ}$  (pin 5) of MAAM-011229 may be used to power down and turn on the amplifier. The critical characteristics of the power down circuit are that it presents a low impedance to DC ground in the off mode and that it presents a high impedance (much greater than 5 k $\Omega$ ) in the on mode. The single very low cost MMBT3904 NPN switching transistor (available from many suppliers) may be added externally along with a 1 k $\Omega$  resistor to provide this function. As shown in plots below, the time from when voltage on the  $I_{ADJ}$  pin ( $V_{ADJ}$ ) goes HIGH to the time RF reaches 90% of final amplitude is 444 ns. The total turn-on time, however, from change of power down signal is 1.18  $\mu$ s (736 ns of this time is consumed in time for MMBT3904 to transition). Alternate choice for switching transistor could reduce total turn-on time. Total turn off time is 392 ns.

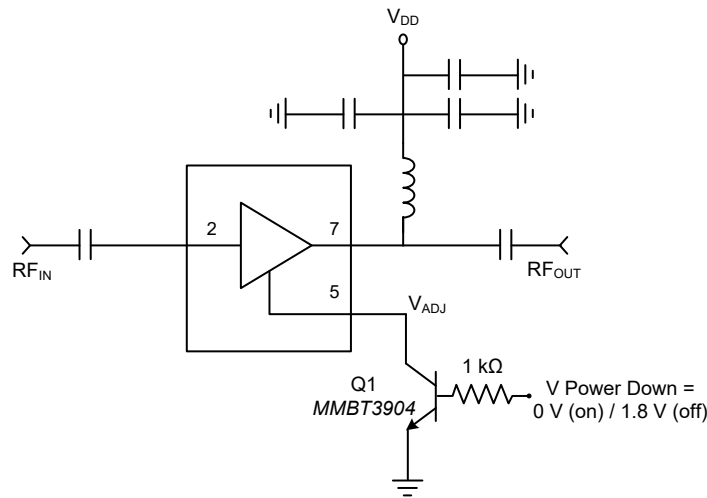

Turn ON Time

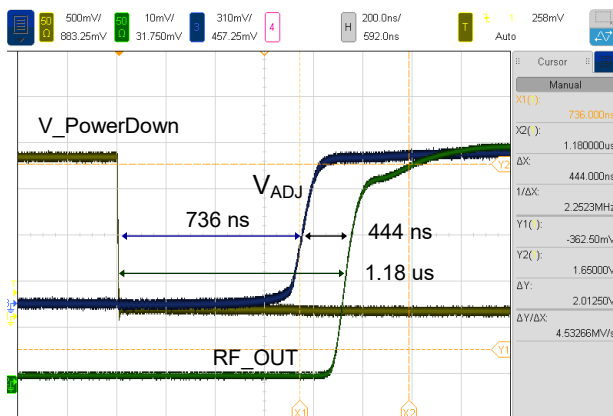

Turn OFF Time

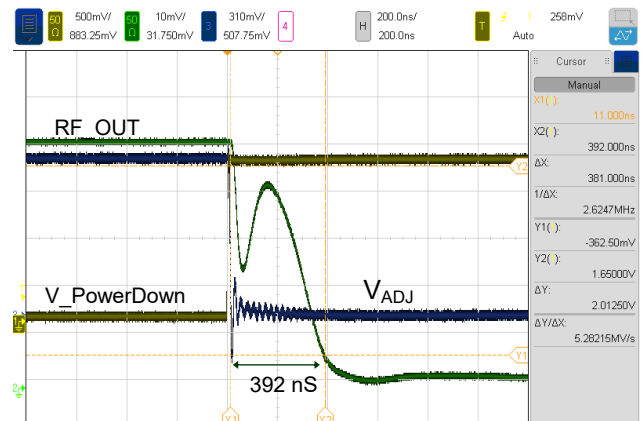

# Broadband Low Noise Amplifier

## 0.05 - 4 GHz



MAAM-011229

Rev. V3

### Lead-Free 2 mm 8-Lead PDFN<sup>†</sup>

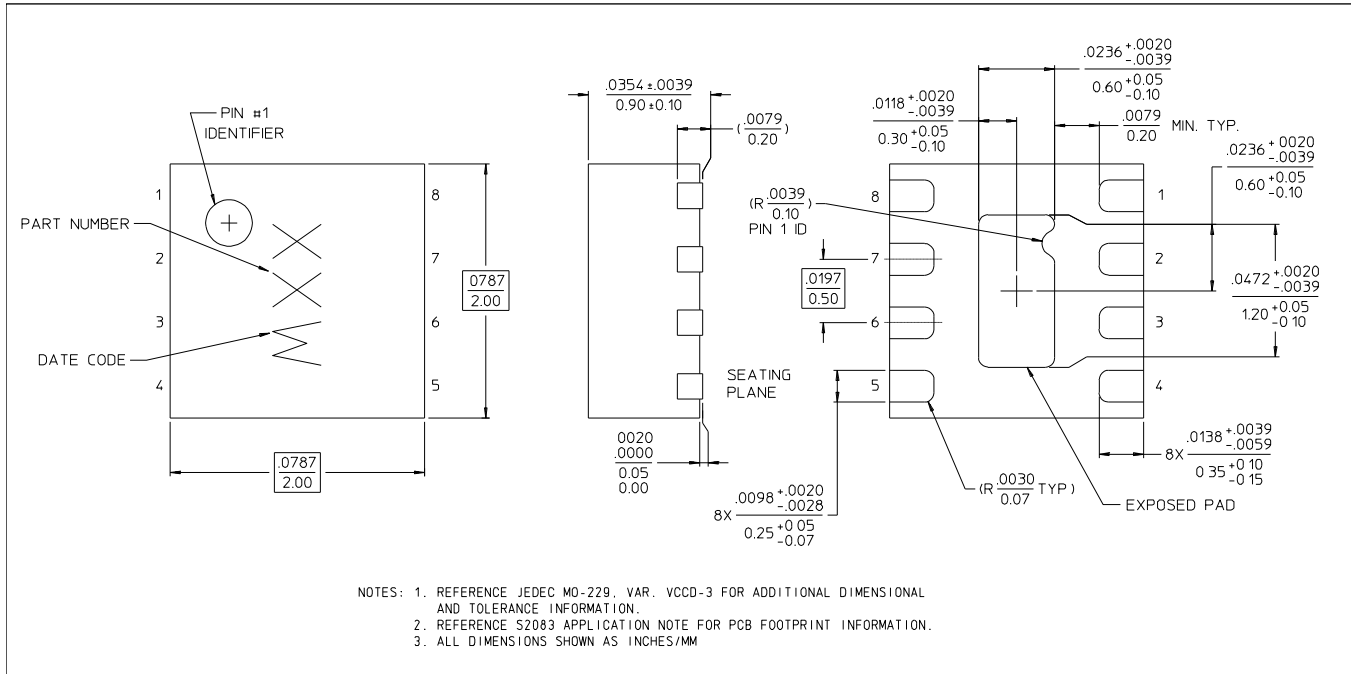

<sup>†</sup> Reference Application Note S2083 for lead-free solder reflow recommendations.  
 Meets JEDEC moisture sensitivity level 1 requirements.  
 Plating is 100% matte tin.

MACOM Technology Solutions Inc. ("MACOM"). All rights reserved.

These materials are provided in connection with MACOM's products as a service to its customers and may be used for informational purposes only. Except as provided in its Terms and Conditions of Sale or any separate agreement, MACOM assumes no liability or responsibility whatsoever, including for (i) errors or omissions in these materials; (ii) failure to update these materials; or (iii) conflicts or incompatibilities arising from future changes to specifications and product descriptions, which MACOM may make at any time, without notice. These materials grant no license, express or implied, to any intellectual property rights.

THESE MATERIALS ARE PROVIDED "AS IS" WITH NO WARRANTY OR LIABILITY, EXPRESS OR IMPLIED, RELATING TO SALE AND/OR USE OF MACOM PRODUCTS INCLUDING FITNESS FOR A PARTICULAR PURPOSE, MERCHANTABILITY, INFRINGEMENT OF INTELLECTUAL PROPERTY RIGHT, ACCURACY OR COMPLETENESS, OR SPECIAL, INDIRECT, INCIDENTAL, OR CONSEQUENTIAL DAMAGES WHICH MAY RESULT FROM USE OF THESE MATERIALS.

MACOM products are not intended for use in medical, lifesaving or life sustaining applications. MACOM customers using or selling MACOM products for use in such applications do so at their own risk and agree to fully indemnify MACOM for any damages resulting from such improper use or sale.

## Looking for pricing, stock, or lifecycle information?

Click below to explore more details on WIN SOURCE:

- ⊖ [View MAAM-011229-TR1000 on WIN SOURCE](#)
- ⊖ [M/A-Com Technology Solutions Information](#)

## Optimize Your Supply Chain with WIN SOURCE Solutions

- ✓ Global Sourcing Solution
- ✓ Obsolete Management
- ✓ Cost Control Management
- ✓ Shortage Management
- ✓ Alternative Solution
- ✓ Excess Inventory Management