



**THE DATASHEET OF
MAAM-011100-TR1000**



Broadband Variable Gain Amplifier (VGA)

400 MHz - 22 GHz



MAAM-011100

Rev. V4

Features

- Gain: 12 dB
- Output Power: 18 dBm
- 50 Ω Input / Output Match over Gain Range
- 30 dB Gain Control with 0 to -2 V Control
- +5 V, -0.5 V DC, 70 mA
- Lead-Free 1.5 x 1.2 mm 6-lead TDFN Package
- RoHS* Compliant

Applications

- Wi-Fi, LTE, Point-to-Point, IMS, EW, A&D

Description

The MAAM-011100 is an easy-to-use, broadband, general purpose variable gain amplifier. Its over 30 dB gain range is controlled by a single control pin and 50 Ω match is maintained over all settings.

The MAAM-011100 operates from 400 MHz to 20 GHz and features flat gain control from +10 dB to -20 dB. At maximum gain setting ($V_C = \text{Open}$) it delivers up to 18 dBm power and under 5 dB noise figure. Both reduce proportionally as gain is reduced with V_C . The input IP3 exceeds 15 dBm at max/min gain settings. The device is typically biased with a $V_D = +5$ V, $V_G = -0.5$ V, and a control of 0 V to -2 V. Typical current is 70 mA with V_G at -0.5 V

The MAAM-011100 is ideally suited for use as a power amplifier driver, gain trimming block, or temperature compensation in the receive or transmit mode.

This device is assembled in a leadless 1.5 x 1.2 mm package that can be handled and placed with standard pick and place assembly equipment.

Ordering Information^{1,2}

Part Number	Package
MAAM-011100	bulk quantity
MAAM-011100-TR1000	1000 piece reel
MAAM-011100-001SMB	Sample board

1. Reference Application Note M513 for reel size information.
2. All sample boards include 5 loose parts.

* Restrictions on Hazardous Substances, compliant to current RoHS EU directive.

Functional Schematic

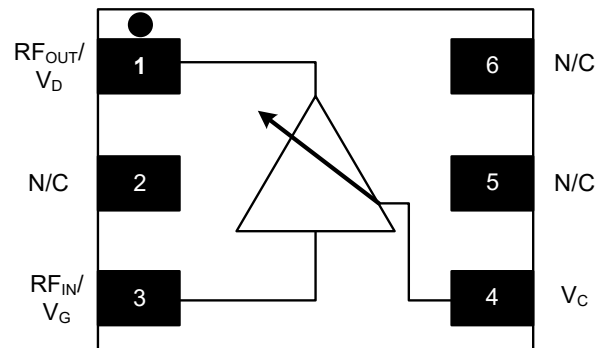

Pin Configuration

Pin #	Pin Name	Function
1	RF _{OUT} /V _D	RF Output
2, 5, 6	N/C	No Connection
3	RF _{IN} /V _G	RF Input
4	V _C	Voltage Control
7	Paddle ³	Ground

3. The exposed paddle centered on the package bottom must be connected to RF and DC ground.

Broadband Variable Gain Amplifier (VGA)

400 MHz - 22 GHz



MAAM-011100

Rev. V4

Electrical Specifications (unless otherwise noted):

Freq = 10 GHz, $T_A = +25^\circ\text{C}$, $V_D = +5\text{ V}$, $V_G = -0.5\text{ V}$, $V_C = \text{Open}$, $Z_{IN} = Z_{OUT} = 50\ \Omega$

Parameter	Test Conditions	Units	Min.	Typ.	Max.
Highest Gain	$V_C = \text{open @ 400 MHz}$ $V_C = \text{open @ 10 GHz}$ $V_C = \text{open @ 20 GHz}$	dB	8	12 10 11	—
Lowest Gain	$V_C = -2\text{ V @ 400 MHz}$ $V_C = -2\text{ V @ 10 GHz}$ $V_C = -2\text{ V @ 20 GHz}$	dB	—	-33 -23 -25	-18
Gain Control	$V_C = 0\text{ to }-2\text{ V}$	dB	—	30	—
Isolation	All States	dB	—	28	—
Input Return Loss	All States	dB	—	14	—
Output Return Loss	All States	dB	—	12	—
Noise Figure	At maximum gain	dB	—	5	—
P1dB	At maximum gain @ 10 GHz	dBm	—	15	—
Input IP3	At maximum or minimum gain	dBm	—	15	—
Stability	Any Load	-	unconditional		
Voltage Supply	External Choke	V	—	5	—
Bias Current ⁴	$V_D = +5.0\text{ V}$ $V_G = -0.5\text{ V}$	mA	—	75 0.01	—

4. See Applications Section for typical V_C current.

Absolute Maximum Ratings^{5,6,7}

Parameter	Absolute Max.
Input Power	15 dBm
Operating Voltage	8 V
Operating Current	110 mA
Junction Temperature ⁸	+150°C
Operating Temperature	-40°C to +85°C
Storage Temperature	-65°C to +150°C

- Exceeding any one or combination of these limits may cause permanent damage to this device.
- MACOM does not recommend sustained operation near these survivability limits.
- Operating at nominal conditions with $T_J \leq 150^\circ\text{C}$ will ensure $\text{MTTF} > 1 \times 10^6$ hours.
- Junction Temperature (T_J) = $T_C + \Theta_{JC} * ((V * I) - (P_{OUT} - P_{IN}))$
Typical thermal resistance (Θ_{JC}) = 67°C/W
 - For $T_C = 25^\circ\text{C}$,
 $T_J = 47^\circ\text{C @ 5 V, 70 mA, } P_{OUT} = 15\text{ dBm, } P_{IN} = 6\text{ dBm}$
 - For $T_C = 85^\circ\text{C}$,
 $T_J = 107^\circ\text{C @ 5 V, 70 mA, } P_{OUT} = 15\text{ dBm, } P_{IN} = 6\text{ dBm}$

Handling Procedures

Please observe the following precautions to avoid damage:

Static Sensitivity

These electronic devices are sensitive to electrostatic discharge (ESD) and can be damaged by static electricity. Proper ESD control techniques should be used when handling these devices.

Broadband Variable Gain Amplifier (VGA) 400 MHz - 22 GHz



MAAM-011100

Rev. V4

Evaluation Board

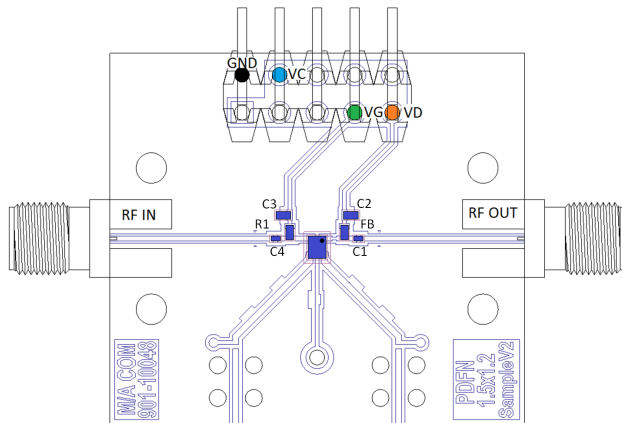

Application Schematic

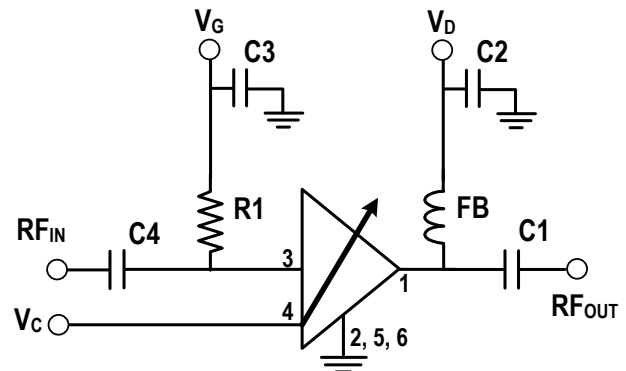

Recommended PCB Layout

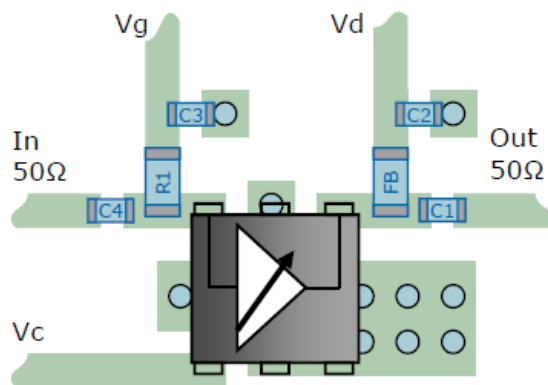

Application Information for DC & pins

For proper MAAM-011100 operation a DC voltage must be applied at the V_G (-0.5V) and V_D (+5 V) pins *in that order*. Adjusting V_G from -0.2 V to -0.6 V will change the quiescent current which can effect power and linearity if set below or above 70 mA.

The gain of the MAAM-011100 is controlled with the V_C pin. The gain reduction is almost linear with V_C between 0 V to -2 V. Below -2 V internal ESD protection diodes will draw increasing current. The nominal open circuit voltage at the V_C pin is +1 V and produces maximum gain and power. Limiting applications and zero crossing adjustment can be done by adjusting the V_G and V_C pins together.

To bias properly, a DC voltage must be applied at the output pin. Typically this is done with a 2 element bias network that consists of a choke and a DC blocking capacitor. We recommend a ferrite bead for the main bias choke and quality capacitor for the DC block. A simple 1 K Ω resistor can be used as a RF choke for the negative V_G as applied to the input pin.

It is recommended that the total ground (common mode) inductance not exceed 0.03 nH (30 pH). This is equivalent to placing at least four 8-mil (200 μ m) diameter vias under the device, assuming an 8-mil (200 μ m) thick RF layer to ground

Parts List

Component	Value	Package
C1, C4	0.22 μ F	0201
C2, C3	0.22 μ F	0402
FB ⁹	407 Ω	0402
R1	1 K Ω	0402

9. MACOM recommends using Murata part BLM15GG471.

Typical Performance Curves over Temperature

Gain, $V_C = 0\text{ V}$

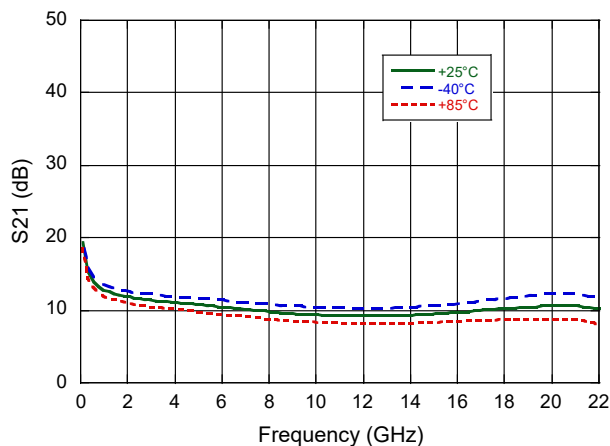

Gain, $V_C = -2\text{ V}$

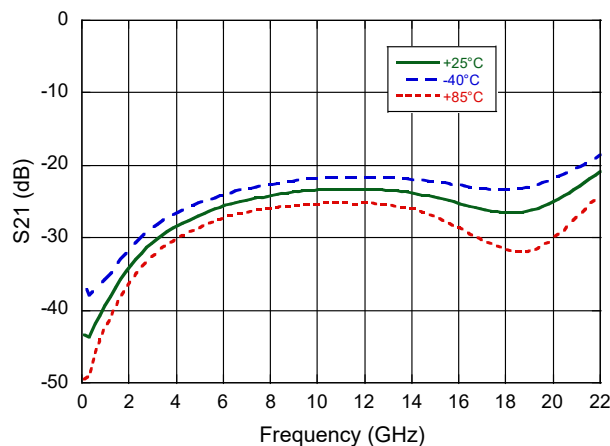

Input Return Loss, $V_C = 0\text{ V}$

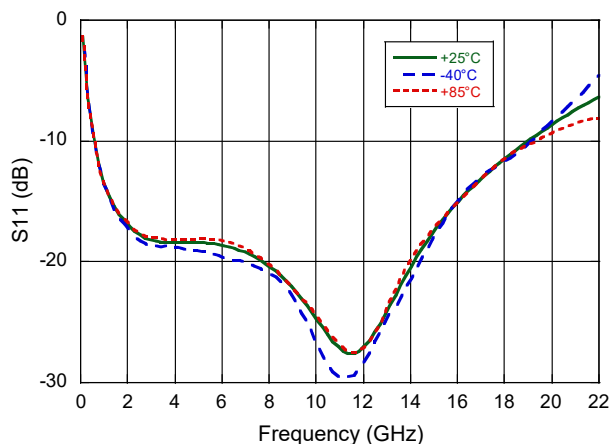

Output Return Loss, $V_C = 0\text{ V}$

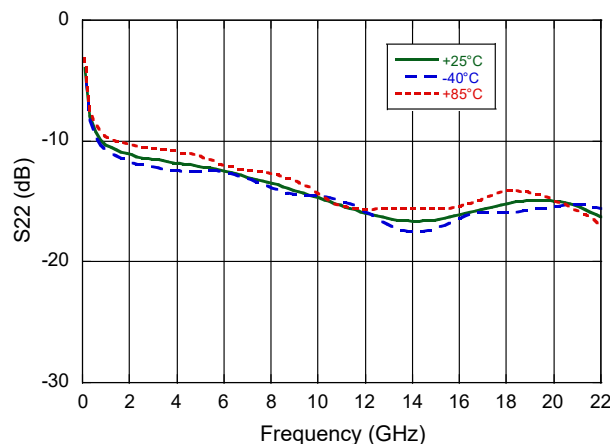

Reverse Isolation, $V_C = 0\text{ V}$

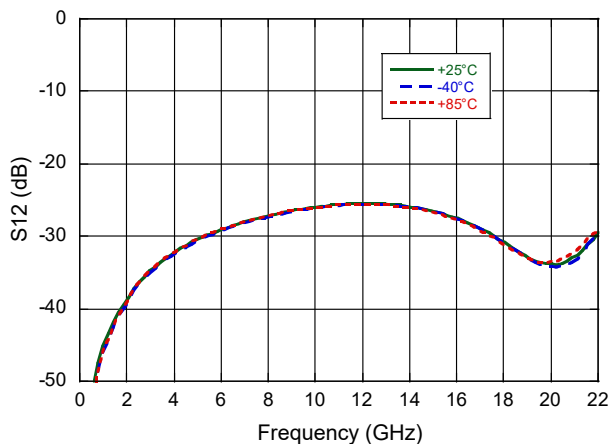

Broadband Variable Gain Amplifier (VGA)

400 MHz - 22 GHz



MAAM-011100

Rev. V4

Typical Performance Curves vs. Control Voltage

Gain

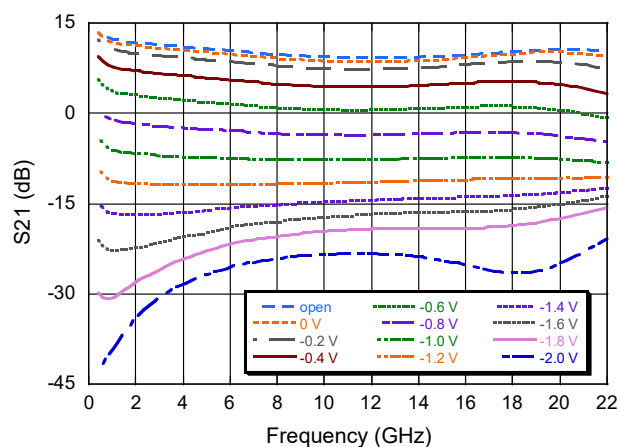

Noise Figure

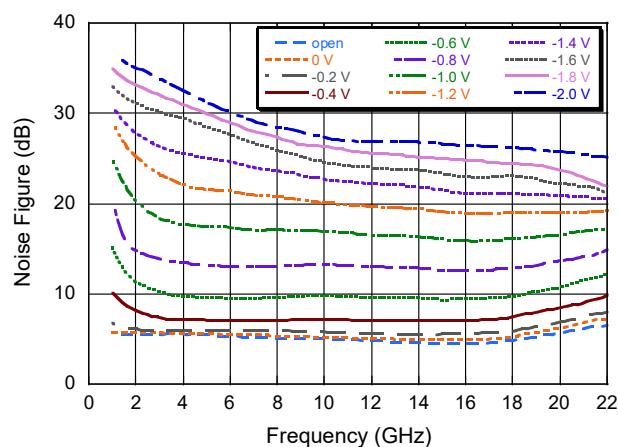

Input Return Loss, $V_C = 0 V$

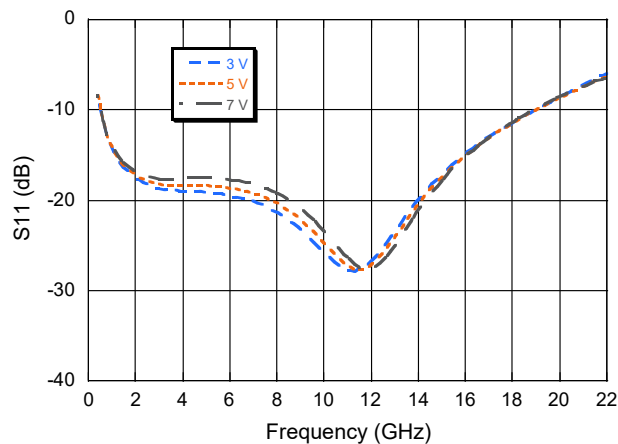

Input Return Loss, $V_C = -2 V$

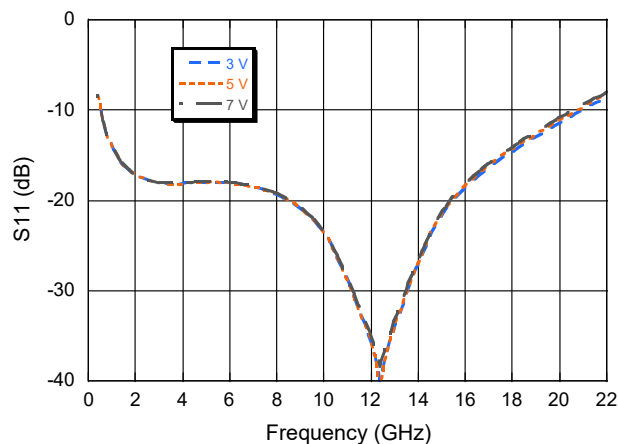

Output Return Loss, $V_C = 0 V$

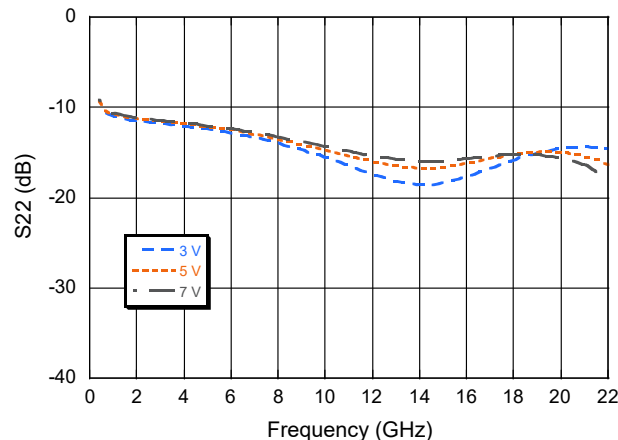

Output Return Loss, $V_C = -2 V$

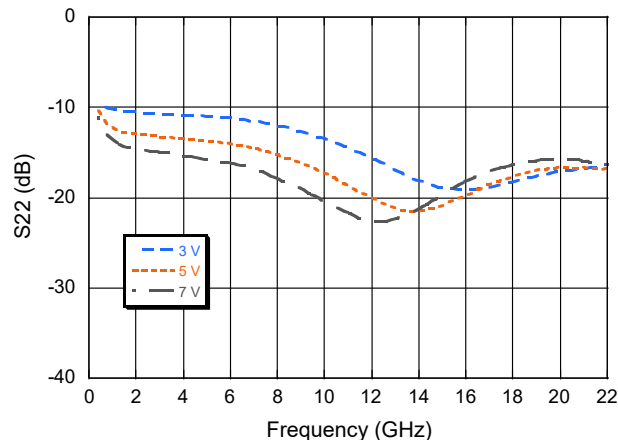

Typical Performance Curves

Noise Figure

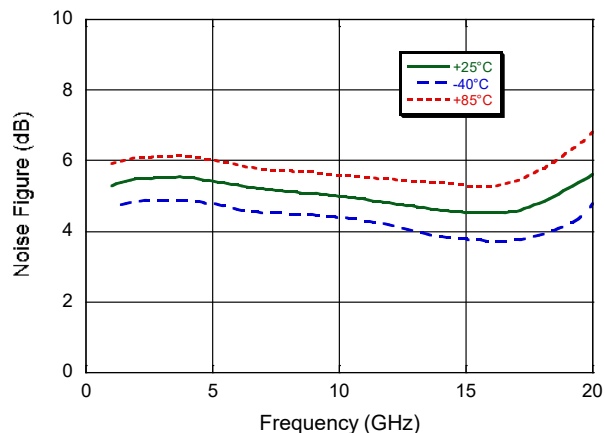

Saturated Power

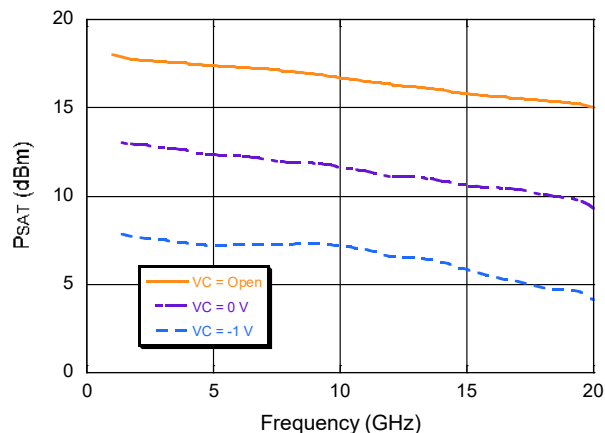

Output P1dB

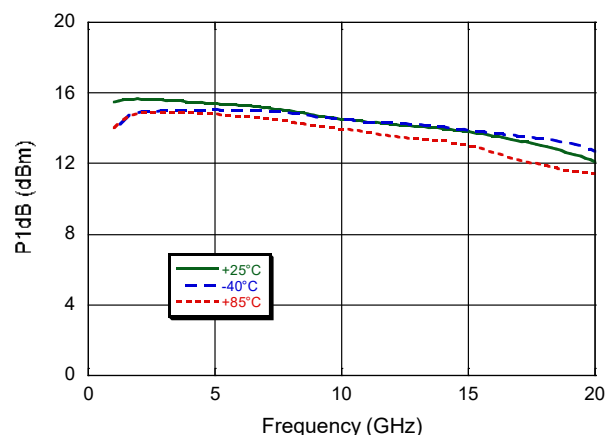

Output P1dB

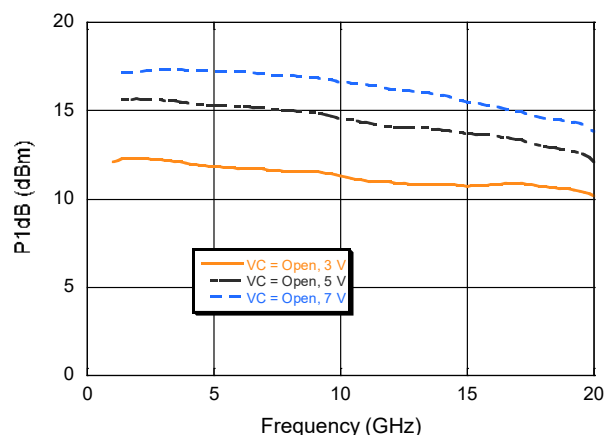

Input IP3

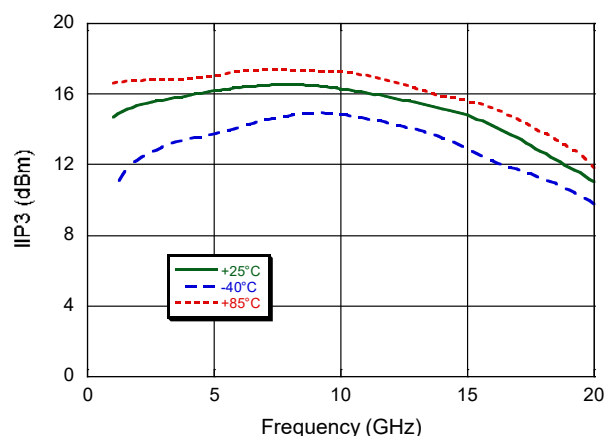

Input IP3

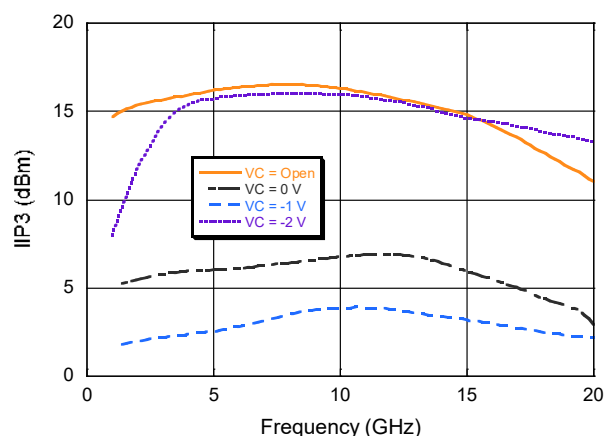

Broadband Variable Gain Amplifier (VGA)

400 MHz - 22 GHz



MAAM-011100

Rev. V4

Typical Performance Curves

Noise Figure @ 10 GHz

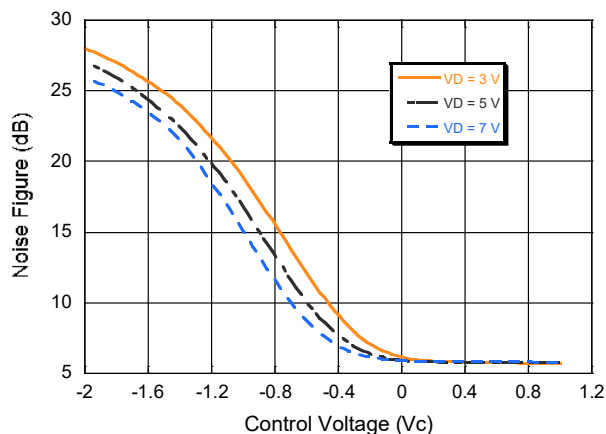

Saturated Power @ 10 GHz

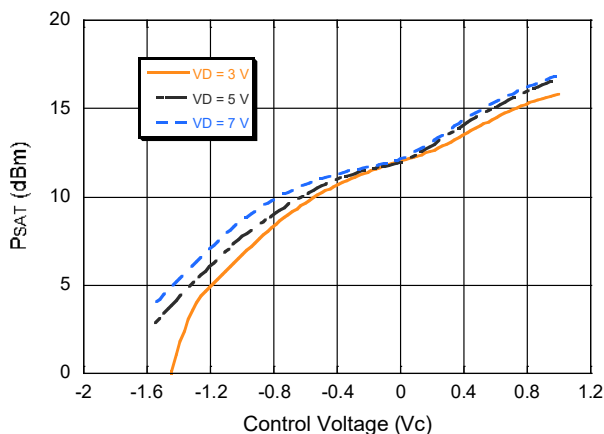

Gain @ 10 GHz

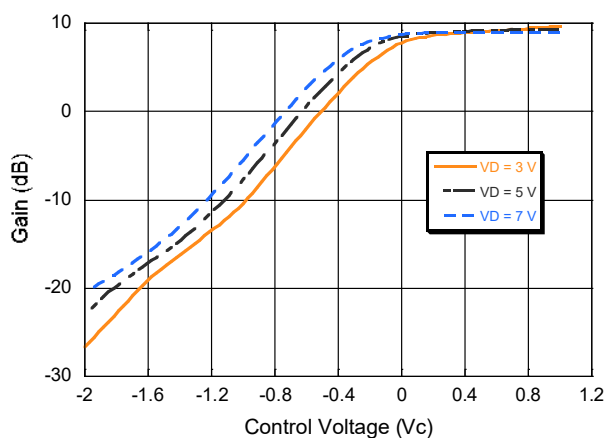

Input IP3 @ 10 GHz

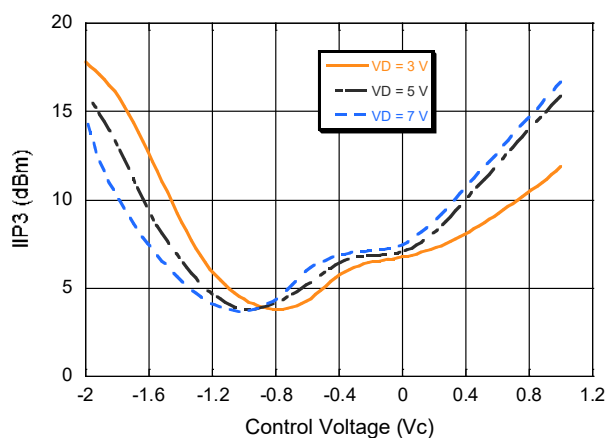

Current @ 10 GHz

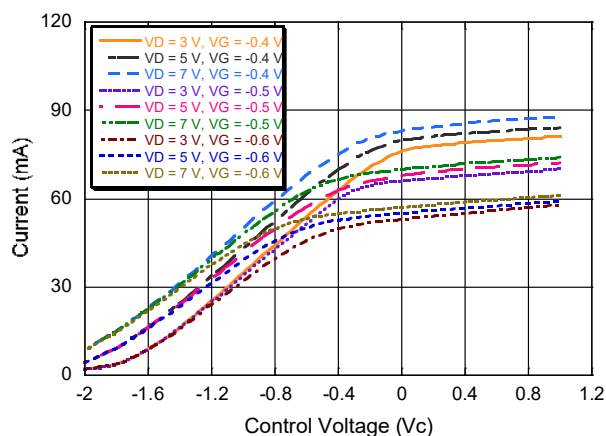

Broadband Variable Gain Amplifier (VGA) 400 MHz - 22 GHz



MAAM-011100

Rev. V4

Lead-Free 1.5 x 1.2 mm 6-lead TDFN

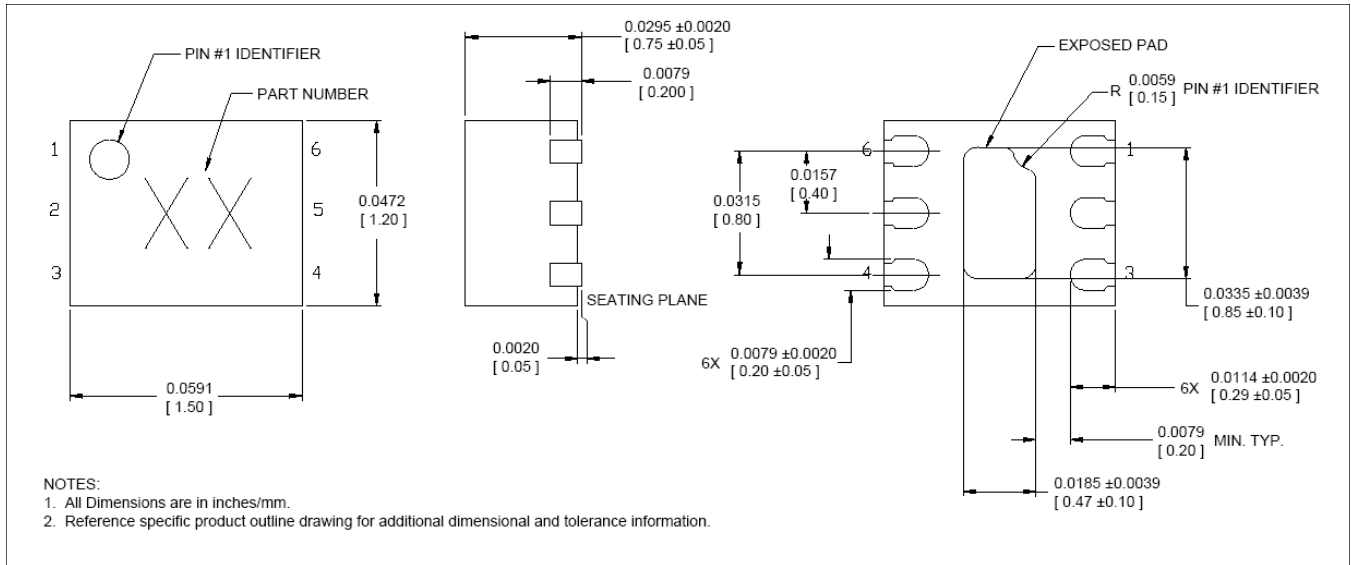

† Reference Application Note S2083 for lead-free solder reflow recommendations.
Meets JEDEC moisture sensitivity level 1 requirements.
Plating is matte tin over copper.

Applications Section: Swept Power Across V_C

Typical Performance Curves:

Measured on Sample Board - Data includes Board/Connector Loss

Gain @ 208 MHz

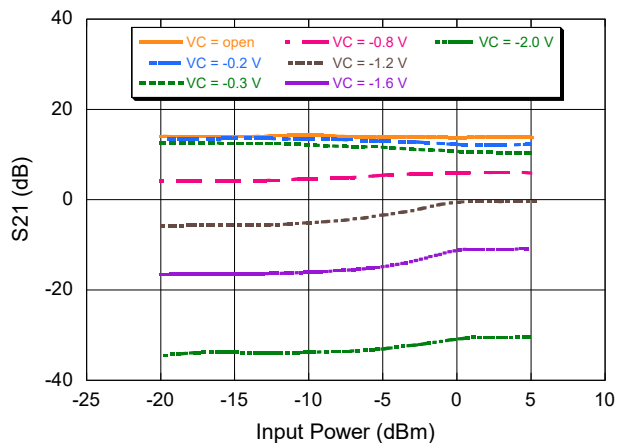

Gain @ 408 MHz

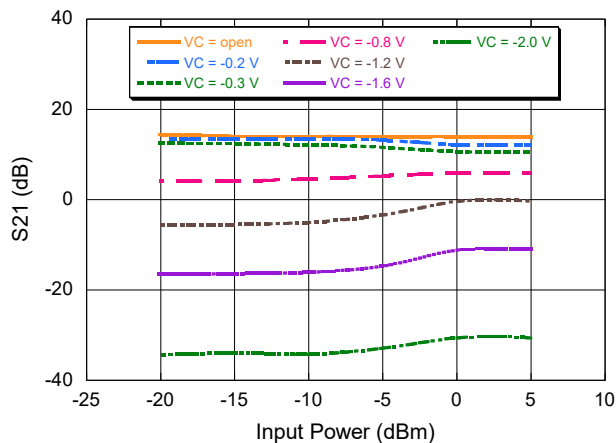

Gain @ 2500 MHz

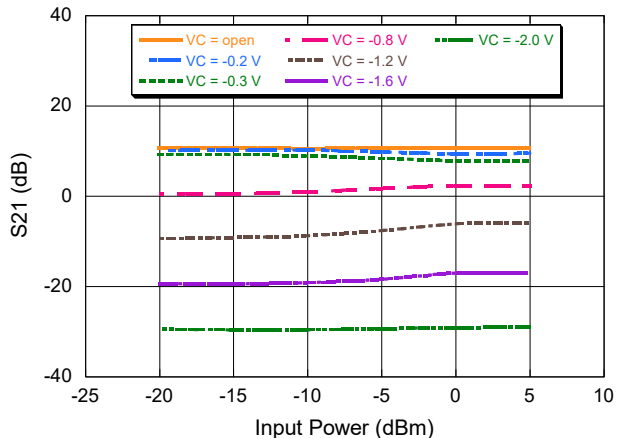

Gain @ 5500 MHz

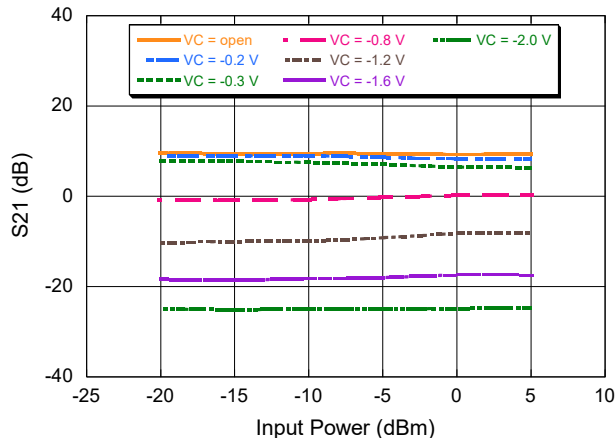

$I(V_C)$ vs. V_C

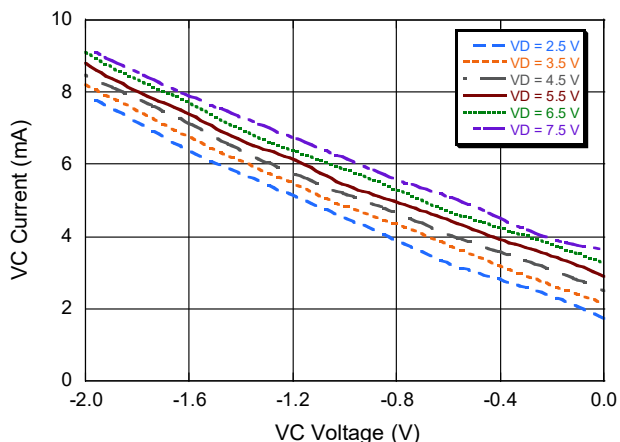

Broadband Variable Gain Amplifier (VGA) 400 MHz - 22 GHz



MAAM-011100

Rev. V4

MACOM Technology Solutions Inc. ("MACOM"). All rights reserved.

These materials are provided in connection with MACOM's products as a service to its customers and may be used for informational purposes only. Except as provided in its Terms and Conditions of Sale or any separate agreement, MACOM assumes no liability or responsibility whatsoever, including for (i) errors or omissions in these materials; (ii) failure to update these materials; or (iii) conflicts or incompatibilities arising from future changes to specifications and product descriptions, which MACOM may make at any time, without notice. These materials grant no license, express or implied, to any intellectual property rights.

THESE MATERIALS ARE PROVIDED "AS IS" WITH NO WARRANTY OR LIABILITY, EXPRESS OR IMPLIED, RELATING TO SALE AND/OR USE OF MACOM PRODUCTS INCLUDING FITNESS FOR A PARTICULAR PURPOSE, MERCHANTABILITY, INFRINGEMENT OF INTELLECTUAL PROPERTY RIGHT, ACCURACY OR COMPLETENESS, OR SPECIAL, INDIRECT, INCIDENTAL, OR CONSEQUENTIAL DAMAGES WHICH MAY RESULT FROM USE OF THESE MATERIALS.

MACOM products are not intended for use in medical, lifesaving or life sustaining applications. MACOM customers using or selling MACOM products for use in such applications do so at their own risk and agree to fully indemnify MACOM for any damages resulting from such improper use or sale.

Looking for pricing, stock, or lifecycle information?

Click below to explore more details on WIN SOURCE:

- ⊖ [View MAAM-011100-TR1000 on WIN SOURCE](#)
- ⊖ [M/A-Com Technology Solutions Information](#)

Optimize Your Supply Chain with WIN SOURCE Solutions

- ✓ Global Sourcing Solution
- ✓ Obsolete Management
- ✓ Cost Control Management
- ✓ Shortage Management
- ✓ Alternative Solution
- ✓ Excess Inventory Management