



**THE DATASHEET OF
M3SWA-2-50DRB+**





FAST SWITCHING

SPDT RF Switch

M3SWA-2-50DRB+

50Ω DC to 4500 MHz Absorptive RF Switch With Internal Driver

THE BIG DEAL

- High Isolation, 56 dB typ.
- High Input IP3, +46.5 dBm typ.
- Low Insertion Loss, 0.6 dB typ.
- Fast Rise/Fall time, 3.3 ns / 4.6 ns typ.
- Tiny Size, 3.25 x 3.25 x 0.9 mm



Generic photo used for illustration purposes only

CASE STYLE: DL805

+RoHS Compliant

The +Suffix identifies RoHS Compliance. See our website for methodologies and qualifications

APPLICATIONS

- Defense
- Communication Infrastructure
- Test and Measurement

PRODUCT OVERVIEW

The M3SWA-2-50DRB+ is a high isolation fast switching absorptive GaAs PHEMT SPDT switch with an internal driver. It operates at +5V & -5V power supplies and has a single TLL compatible control port. It has been designed for wideband operation and packaged in a tiny 3.25mm x 3.25mm, 8-lead package.

KEY FEATURES

Features	Advantages
Wideband, DC to 4.5 GHz	One model can be used in many applications, saving component count. Also ideal for wideband applications such as military and instrumentation.
Absorptive Switch	In the OFF condition, RF output ports which are not switched ON are terminated into 50Ω. This enables proper impedance termination of the circuitry following the RF output ports, preventing any unintended action such as oscillation.
High Isolation: <ul style="list-style-type: none"> • 62 dB at 1000 MHz • 35 dB at 4500 MHz 	High isolation significantly reduces leakage of power into OFF ports.
High Linearity: <ul style="list-style-type: none"> Input power at P1dB, 25.4 dBm typ. Input IP3, +46.5 dBm typ. 	High linearity minimizes unwanted inter modulation products which are difficult or impossible to filter in multi-carrier environments such as CATV, or in the presence of strong interfering signal from adjacent circuitry or received by antenna.
Form-fit compatible with M3SWA-2-50DR+	Fits into existing PCB footprint designed for M3SW-2-50DR+ with minor electrical differences.
Tiny size, 3.25 x 3.25 mm MCLP package	Tiny footprint saves space in dense layouts while providing low inductance, repeatable transitions, and excellent thermal contact to the PCB.

REV. A
ECO-014399
M174743
M3SWA-2-50DRB+
GV/RS/CP
220729



**FAST SWITCHING**

SPDT RF Switch

M3SWA-2-50DRB+

50Ω DC to 4500 MHz Absorptive RF Switch With Internal Driver

RF ELECTRICAL SPECIFICATIONS¹, T_{AMB}=25°C, 50Ω, V_{DD}= +5V, V_{EE}= -5V

Parameter	Condition (MHz)	Min.	Typ.	Max.	Units
Frequency Range ³		DC		4500	MHz
Insertion Loss	10 - 100	—	0.5	1.0	dB
	100 - 1000	—	0.6	1.2	
	1000 - 2000	—	0.6	1.4	
	2000 - 4000	—	0.7	2.0	
	4000 - 4500	—	1.4	2.5	
Isolation between Output Port 1 & 2	10 - 100		78		dB
	100 - 1000		59		
	1000 - 2000		49		
	2000 - 4000		39		
	4000 - 4500		32		
Isolation between Common Port & Output Ports	10 - 100	65	97	—	dB
	100 - 1000	53	75	—	
	1000 - 2000	45	56	—	
	2000 - 4000	30	43	—	
	4000 - 4500	30	36	—	
Input Return Loss	10 - 100		29		dB
	100 - 1000		30		
	1000 - 2000		27		
	2000 - 4000		23		
	4000 - 4500		22		
Output Return Loss (Both ON STATE & OFF STATE)	10 - 100		29		dB
	100 - 1000		28		
	1000 - 2000		22		
	2000 - 4000		19		
	4000 - 4500		14		
Input Power at P1dB ²	10 - 100		19.2		dBm
	100 - 1000		24.5		
	1000 - 2000		25.4		
	2000 - 4000		25.0		
	4000 - 4500		23.8		
Input IP3 (Pout=0 dBm/Tone)	10 - 100		39.7		dBm
	100 - 1000		44.7		
	1000 - 2000		46.5		
	2000 - 4000		44.0		
	4000 - 4500		40.1		
Thermal Resistance - Junction-to-ground lead at 85°C stage temperature			34.2		°C/W



**FAST SWITCHING**

SPDT RF Switch

M3SWA-2-50DRB+

50Ω DC to 4500 MHz Absorptive RF Switch With Internal Driver

DC ELECTRICAL SPECIFICATIONS

Parameter	Min.	Typ.	Max.	Units
Positive Supply Voltage, V_{DD}	4.75	5	5.25	V
Negative Supply voltage, V_{EE}	-5.25	-5	-4.75	V
Positive Supply Current, I_{DD}	—	5	9	mA
Negative Supply Current, I_{EE}	-9	-3	—	mA
Control Voltage Low	—	0	0.8	V
Control Voltage High	+2.1	+2.3	+5	V
Control Current Low	—	0	0.2	mA
Control Current High	—	0.4	5	mA

1. Tested on Mini-Circuits' test board TB-M3SW-250DRA+ (See Fig.1)
2. Input Power at P1dB compression drops to 13 dB at 10 MHz.
3. All RF-ports must be DC blocked or held at 0V DC

SWITCHING SPECIFICATIONS

Parameter	Condition	Min.	Typ.	Max.	Units
ON Time, 50% control to 90% RF	RF Pin= 0 dBm RF Freq.= 500 MHz Control Freq.= 500 KHz Control High= 2.3V Control Low= 0V		14.4		ns
OFF Time, 50% control to 10% RF			11.3		ns
Video Leakage			42.5		mV
Rise Time, 10% RF to 90% RF 10 to 90% or 90 to 10%			3.3		ns
Fall Time, 90% RF to 10% RF			4.6		ns

MAXIMUM RATINGS⁴

Parameter	Ratings
Operating Temperature	-55°C to +100°C
Storage Temperature	-55°C to +100°C
RF Input Power	+24 dBm
Junction Temperature	134°C
Total Power Dissipation	0.4W
DC Voltage, Pin 5	+6V
DC Voltage, Pin 7	-6V

4. Permanent damage may occur if any of these limits are exceeded. Electrical Maximum ratings are not intended for continuous normal operation.

TRUTH TABLE

State of Control Voltage	RF-IN to RF-OUT1	RF-IN to RF-OUT 2
LOW	ON	OFF
HIGH	OFF	ON





FAST SWITCHING

SPDT RF Switch

M3SWA-2-50DRB+

50Ω DC to 4500 MHz Absorptive RF Switch With Internal Driver

SIMPLIFIED SCHEMATIC AND PAD DESCRIPTION

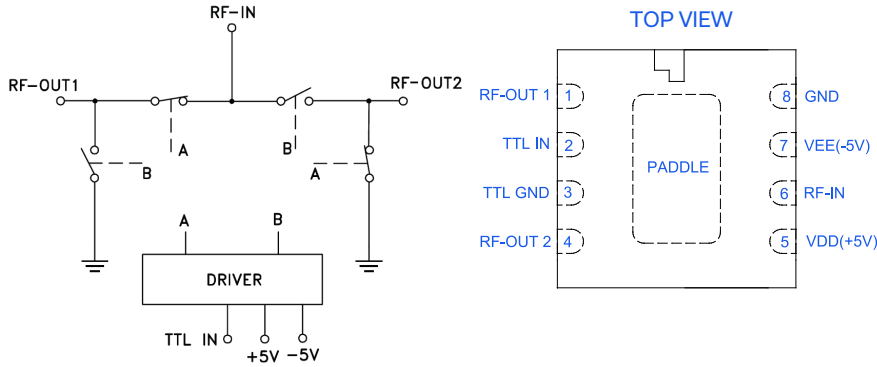

Function	Pad Number	Description
RF-IN	6	RF Common/ SUM port
RF-OUT1	1	RF Output port #1
RF-OUT2	4	RF Output port #2
TTL IN	2	TTL Compatible Control Voltage Input
TTL GND	3	TTL Ground
V _{DD} (+5V)	5	Positive Supply Voltage V _{DD}
V _{EE} (-5V)	7	Negative Supply Voltage V _{EE}
GND	8, paddle	Ground

CHARACTERIZATION & APPLICATION CIRCUIT

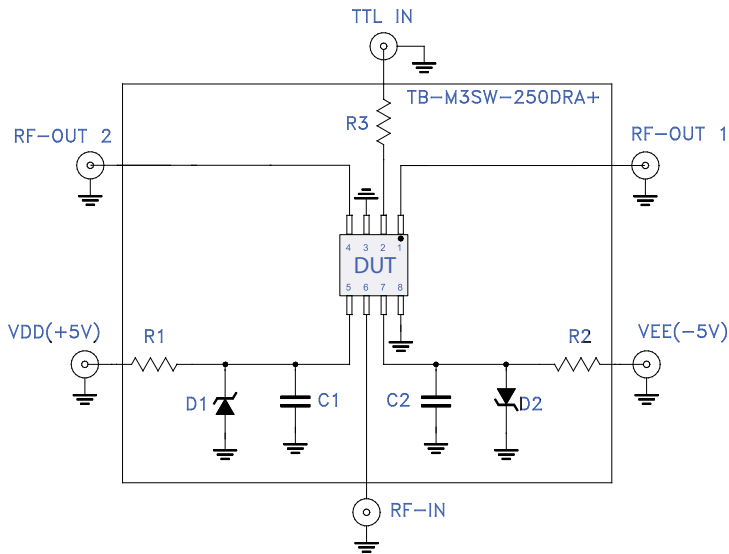

Component	Size	Value	P/N	Manufacturer
DUT	3.25x3.25	N/A	M3SW-2-50DRA+	MCL
D1, D2	SOD-123	V _z = 5.6V	MMSZ4690T1G	ON Semiconductor
R1, R2	0603	11.5Ω	RK73H1JTTD11R5F	KOA
R3	0603	100Ω	RK73H1JTTD1000F	KOA
C1, C2	0603	10pF	06031A100GAT2A	AVX

Note: D1&D2 are optional.

Figure 1. Characterization & Application Circuit

Note: (DUT soldered on Mini-Circuits Characterization & Application Test Board TB-M3SW-2-50DRA+).

Insertion Loss, Amplitude Unbalance, Isolation, Return Loss, Input Power at 1dB Compression (P_{1dB}) & Input IP₃ tested using E5071C microwave network analyzer.

Condition:

1. Insertion Loss, Amplitude Unbalance, Isolation & Return Loss: Pin = 0dBm
2. Input IP₃(IIP₃): Two tones, spaced 1 MHz apart, 0dBm/tone output.

PRODUCT MARKING

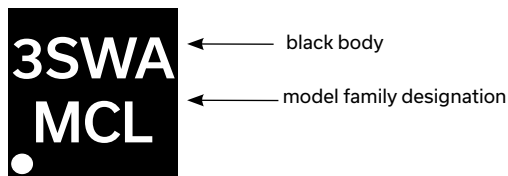

Marking may contain other features or characters for internal lot control





FAST SWITCHING

SPDT RF Switch

M3SWA-2-50DRB+

50Ω DC to 4500 MHz Absorptive RF Switch With Internal Driver

ADDITIONAL DETAILED TECHNICAL INFORMATION IS AVAILABLE ON OUR DASH BOARD. TO ACCESS [CLICK HERE](#)

Performance Data	Data Table Swept Graphs
Case Style	DL805 Plastic package, exposed paddle , lead finish=Matte-Tin
Tape & Reel	F58
Standard quantities available on reel	7" reels with 1000 devices 13" reels with 2000, 4000 devices
Suggested Layout for PCB Design	PL-120
Evaluation Board	TB-M3SWA250DRB+
Environmental Ratings	ENV16

ESD RATING

Human Body Model (HBM): Class 0 (Pass 100V) in accordance with ESD STM5.1-2001

MSL RATING

Moisture Sensitivity: MSL1 in accordance with IPC/JEDEC J-STD-020D

MSL TEST FLOW CHART

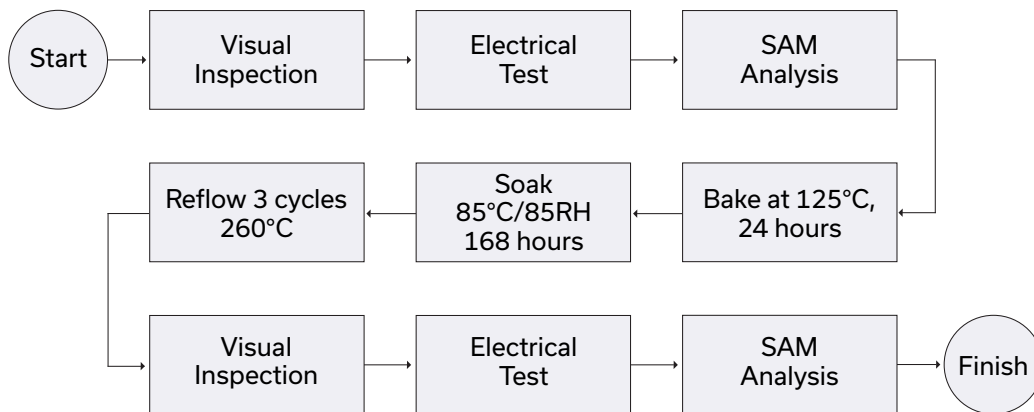



NOTES

- A. Performance and quality attributes and conditions not expressly stated in this specification document are intended to be excluded and do not form a part of this specification document.
- B. Electrical specifications and performance data contained in this specification document are based on Mini-Circuit's applicable established test performance criteria and measurement instructions.
- C. The parts covered by this specification document are subject to Mini-Circuits standard limited warranty and terms and conditions (collectively, "Standard Terms"); Purchasers of this part are entitled to the rights and benefits contained therein. For a full statement of the standard terms and the exclusive rights and remedies thereunder, please visit Mini-Circuits' website at www.minicircuits.com/terms/viewterm.html



Looking for pricing, stock, or lifecycle information?

Click below to explore more details on WIN SOURCE:

-  [View M3SWA-2-50DRB+ on WIN SOURCE](#)
-  [Mini-Circuits Information](#)

Optimize Your Supply Chain with WIN SOURCE Solutions

-  Global Sourcing Solution
-  Obsolete Management
-  Cost Control Management
-  Shortage Management
-  Alternative Solution
-  Excess Inventory Management