



**THE DATASHEET OF
M29W640GB70ZF3F TR**



Parallel NOR Flash Embedded Memory

M29W640GH, M29W640GL**M29W640GT, M29W640GB**

Features

- Supply voltage
 - $V_{CC} = 2.7\text{--}3.6\text{V}$ (program, erase, read)
 - $V_{PP} = 12\text{V}$ for fast program (optional)
- Asynchronous random/page read
 - Page width: 4 words
 - Page access: 25ns
 - Random access: 60ns, 70ns, 90ns
- Fast program commands
 - 2-word/4-byte program (without $V_{PP} = 12\text{V}$)
 - 4-word/8-byte program (with $V_{PP} = 12\text{V}$)
 - 16-word/32-byte write buffer
- Programming time
 - 10 μs per byte/word TYP
 - Chip program time: 10 s (4-word program)
 - Double word/quadruple byte program
- Memory organization
 - M29W640GH/L 128 main blocks, 64KB each
 - M29W640GT/B 127 main blocks, 64KB each and 8 boot blocks, 8KB each
- Program/erase controller
 - Embedded byte/word program algorithms
- Program/erase suspend and resume
 - Read from any block during a PROGRAM SUSPEND operation
 - Read or program another block during an ERASE SUSPEND operation
- Hardware block protection
 - $V_{PP}/WP\#$ pin for fast program and write protect
 - Temporary block unprotect mode
- Common Flash interface
 - 64-bit security code
- 128-word extended memory block
 - Extra block used as security block or to store additional information
- Low power consumption: Standby and automatic mode
- 100,000 PROGRAM/ERASE cycles per block
- Electronic signature
 - Manufacturer code: 0020h
- Device summary: part number and device code
 - M29W640GH: uniform, last block protected by $V_{PP}/WP\#$
 - 227Eh + 220Ch + 2201h
 - M29W640GL: uniform, first block protected by $V_{PP}/WP\#$
 - 227Eh + 220Ch + 2200h
 - M29W640GT: top boot block
 - 227Eh + 2210h + 2201h
 - M29W640GB: bottom boot block
 - 227Eh + 2210h + 2200h
- RoHS-compliant packages
 - 48-pin TSOP (N/NA) 12mm x 20mm
 - 56-pin TSOP (NB) 14mm x 20mm
 - 48-ball TFBGA (ZA) 6mm x 8mm
 - 64-ball FBGA (ZS) 11mm x 13mm
 - 64-ball TBGA (ZF) 10mm x 13mm
- Automotive certified parts available

Part Numbering Information

Available with extended memory block prelocked by Micron. Devices are shipped from the factory with memory content bits erased to 1. For available options, such as packages or speed, or for further information, contact your Micron sales representative. Part numbers can be verified at www.micron.com. Feature and specification comparison by device type is available at www.micron.com/products. Contact the factory for devices not found.

Table 1: Part Number Information

Part Number Category	Category Details
Device Type	M29 = Parallel Flash memory
Operating Voltage	W = 2.7 to 3.6V
Device Function	640G = 64Mb (x8/x16) boot block, uniform or boot block
Array Matrix	T = Top boot
	B = Bottom boot
	L = First block protected by V _{pp} /WP#
	H = Last block protected by V _{pp} /WP#
Speed	60 = 60ns (in conjunction with temperature range 6; denotes industrial grade -40°C to 85°C parts)
	6A = 60ns (in conjunction with temperature range 6; denotes automotive grade -40°C to 85°C parts)
	7A = 70ns (in conjunction with temperature range 6; denotes automotive grade -40°C to 85°C parts)
	70 = 70ns (in conjunction with temperature range 6; denotes industrial grade -40°C to 85°C parts; temperature range = 3 denotes automotive grade -40°C to 125°C parts)
	90 = 90ns (in conjunction with temperature range 6; denotes industrial grade -40°C to 85°C parts)
Package	N/NA = 48-pin TSOP, 12mm x 20mm
	NB = 56-pin TSOP, 14mm x 20mm (available upon request)
	ZA = 48-ball TFBGA, 6mm x 8mm, 0.8mm pitch
	ZS = 64-ball FBGA, 11mm x 13mm, 1mm pitch
	ZF = 64-ball TBGA, 10mm x 13mm, 1mm pitch (available upon request)
Temperature Range	6 = -40°C to 85°C
	3 = -40°C to 125°C (Automotive)
Shipping Options	E = RoHS-compliant package, standard packing
	F = RoHS-compliant package, tape and reel packing

Contents

General Description	7
Signal Assignments	10
Signal Descriptions	14
Memory Organization	17
Memory Configuration	17
Uniform Block Memory Map, x16 – 64Mb Density	17
Uniform Block Memory Map, x8 – 64Mb Density	17
Bus Operations	18
Read	18
Write	18
Standby and Automatic Standby	18
Output Disable	18
Status Register	19
Data Polling Bit (DQ7)	19
Toggle Bit (DQ6)	19
Error Bit (DQ5)	19
Erase Timer Bit (DQ3)	20
Alternative Toggle Bit (DQ2)	20
Write to Buffer and Program Abort Bit (DQ1)	20
READ Operations	24
READ/RESET Command	24
READ CFI Command	24
AUTO SELECT Operations	25
AUTO SELECT Command	25
Command Interface	28
READ/RESET Command	28
AUTO SELECT Command	28
READ CFI QUERY Command	28
PROGRAM Command	29
PROGRAM SUSPEND Command	29
PROGRAM RESUME Command	30
Fast Program Commands	30
DOUBLE BYTE PROGRAM Command	30
QUADRUPLE BYTE PROGRAM Command	30
OCTUPLE BYTE PROGRAM Command	30
DOUBLE WORD PROGRAM Command	31
QUADRUPLE WORD PROGRAM Command	31
WRITE TO BUFFER AND PROGRAM Command	32
WRITE TO BUFFER AND PROGRAM CONFIRM Command	33
WRITE TO BUFFER AND PROGRAM ABORT AND RESET Command	33
UNLOCK BYPASS Command	33
UNLOCK BYPASS PROGRAM Command	33
UNLOCK BYPASS RESET Command	34
CHIP ERASE Command	34
BLOCK ERASE Command	34
ERASE SUSPEND Command	35
ERASE RESUME Command	35
ENTER EXTENDED BLOCK Command	35
EXIT EXTENDED BLOCK Command	35
BLOCK PROTECT and CHIP UNPROTECT Commands	36



64Mb: 3V Embedded Parallel NOR Flash Features

BLOCK PROTECT Command	36
Programmer Technique	36
In-System Technique	39
Common Flash Interface	46
Absolute Ratings and Operating Conditions	51
DC Characteristics	53
Read AC Characteristics	54
Write AC Characteristics	57
Toggle and Alternative Toggle AC Characteristics	61
Program/Erase Characteristics	63
Reset Characteristics	67
Package Dimensions	68
Revision History	73
Rev. D – 03/15	73
Rev. C – 07/13	73
Rev. B – 06/13	73
Rev. A – 11/12	73

List of Figures

Figure 1: Logic Diagram	8
Figure 2: 48-Pin TSOP	10
Figure 3: 56-Pin TSOP	11
Figure 4: 48-Ball TFBGA	12
Figure 5: 64-Ball TFBGA	13
Figure 6: Data Polling Flowchart	22
Figure 7: Data Toggle Flowchart	23
Figure 8: Programmer Equipment Block Protect Flowchart	37
Figure 9: Programmer Equipment Chip Unprotect Flowchart	38
Figure 10: In-System Equipment Block Protect Flowchart	40
Figure 11: In-System Equipment Chip Protect Flowchart	41
Figure 12: AC Measurement Load Circuit	52
Figure 13: AC Measurement I/O Waveform	52
Figure 14: Random AC Timing	55
Figure 15: Page Read AC Timing	56
Figure 16: WE#-Controlled AC Timing	58
Figure 17: CE#-Controlled AC Timing	60
Figure 18: Toggle/Alternative Toggle, CE# Controlled	61
Figure 19: Toggle/Alternative Toggle, OE# Controlled	62
Figure 20: WE# Controlled Program Waveform	64
Figure 21: CE# Controlled Program Waveform	65
Figure 22: Chip/Block Erase Waveform	66
Figure 23: Reset/Block Temporary Unprotect AC Waveforms	67
Figure 24: Accelerated Programming Timing Waveform	67
Figure 25: 48-Pin TSOP – 12mm x 20mm	68
Figure 26: 56-Pin TSOP – 14mm x 20mm	69
Figure 27: 48-Ball TFBGA – 6mm x 8mm	70
Figure 28: 64-Ball TBGA – 10mm x 13mm	71
Figure 29: 64-Ball FBGA – 11mm x 13mm	72

List of Tables

Table 1: Part Number Information	2
Table 2: Signal Names	8
Table 3: Protection Granularity on the M29W640GH and M29W640GL	9
Table 4: Protection Granularity on the M29W640GT	9
Table 5: Protection Granularity on the M29W640GB	9
Table 6: Signal Descriptions	14
Table 7: Hardware Protection	16
Table 8: x16 Uniform Blocks [127:0]	17
Table 9: x8 Uniform Blocks [127:0]	17
Table 10: Bus Operations	18
Table 11: Status Register Bits	20
Table 12: Read Electronic Signature	25
Table 13: Block Protection	26
Table 14: Programmer Technique Bus Operations	39
Table 15: Commands – 16-Bit Mode (BYTE# = V _{IH})	42
Table 16: Commands – 8-Bit Mode (BYTE# = V _{IL})	44
Table 17: Query Structure Overview	46
Table 18: CFI Query Identification String	46
Table 19: CFI Query System Interface Information	47
Table 20: Device Geometry Definition	47
Table 21: Primary Algorithm-Specific Extended Query Table	48
Table 22: Security Code Area	50
Table 23: Absolute Maximum/Minimum Ratings	51
Table 24: Operating Conditions	51
Table 25: Input/Output Capacitance	52
Table 26: DC Current Characteristics	53
Table 27: DC Voltage Characteristics	53
Table 28: Read AC Characteristics	54
Table 29: WE#-Controlled Write AC Characteristics	57
Table 30: CE#-Controlled Write AC Characteristics	59
Table 31: Toggle and Alternative Toggle AC Characteristics	61
Table 32: Program/Erase Times and Endurance Cycles	63
Table 33: Reset/Block Temporary Unprotect AC Characteristics	67

General Description

The M29W640G is a 64Mb (8Mb x8 or 4Mb x16) nonvolatile memory that can be read, erased, and reprogrammed. These operations can be performed using a single low voltage (2.7–3.6V) supply. Upon power-up, the device defaults to read mode.

The memory is divided into blocks that can be erased independently so that valid data can be preserved while old data is erased. PROGRAM and ERASE commands are written to the command interface of the memory. An on-chip program/erase controller simplifies the process of programming or erasing the memory by taking care of all special operations required to update the memory contents. The end of a PROGRAM or ERASE operation can be detected and any error condition can be identified. The command set required to control the device is consistent with JEDEC standards.

The M29W640GH and M29W640GL memory array is organized into 128 uniform blocks of 64KB each (or 32Kwords each).

The M29W640GT and M29W640GB feature an asymmetric memory block, each having an array of 135 blocks divided into 8 parameter blocks of 8KB each (or 4 Kwords each), and 127 main blocks of 64KB each (or 32Kwords each). The M29W640GT has the parameter blocks at the top of the memory array whereas the M29W640GB locates the parameter blocks starting from the bottom.

Blocks are protected by groups to prevent accidental PROGRAM or ERASE commands from modifying the memory.

The M29W640G supports asynchronous random read and page read from all blocks of the array. Chip enable, output enable, and write enable signals control the bus operation. They enable simple connection to most microprocessors, often without additional logic.

The $V_{pp}/WP\#$ signal is used to enable faster programming of the device. Protection from PROGRAM/ERASE commands can be obtained by holding $V_{pp}/WP\#$ to V_{SS} :

- On the M29W640GH and M29W640GL, the last and first blocks are protected.
- On the M29W640GT and M29W640GB, the last two and first two boot blocks are protected.

The M29W640G devices feature a full set of fast program commands to improve programming throughput:

- 2-byte PROGRAM (it is not necessary to raise $V_{pp}/WP\#$ to 12V before issuing this command)
- 2 words/4-byte PROGRAM (it is not necessary to raise $V_{pp}/WP\#$ to 12V before issuing this command)
- 4 word/8-byte PROGRAM ($V_{pp}/WP\#$ must be raised to 12V before issuing this command)
- WRITE TO BUFFER and PROGRAM (enables program in one shot a buffer of 16 words/32 bytes)

The M29W640G has an extra block, the extended block, of 128 words in x16 mode or 256 bytes in x8 mode that can be accessed using a dedicated command. The extended block can be protected, and therefore, is useful for storing security information. However, protection is not reversible; once protected, the protection cannot be undone.

The memory is delivered with all bits erased (set to 1).

Figure 1: Logic Diagram

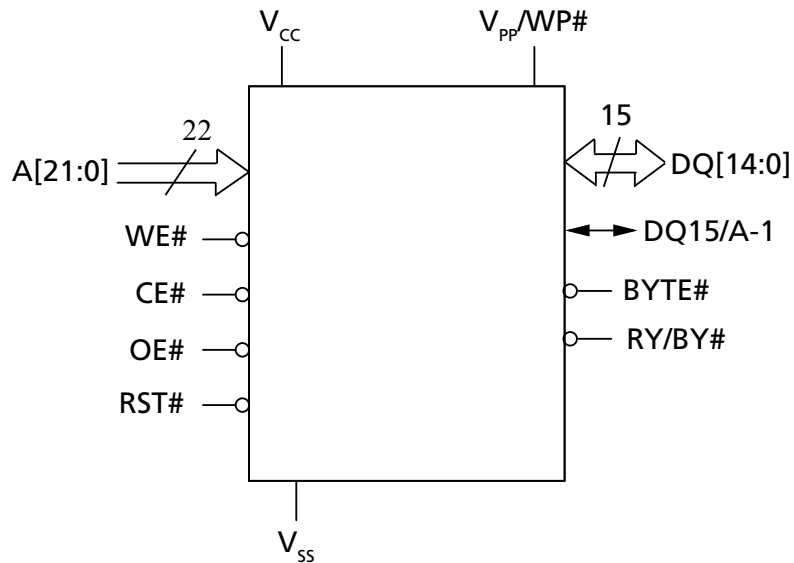

Table 2: Signal Names

Name	Description	Direction
A0-A21	Address inputs	Inputs
CE#	Chip enable	Input
OE#	Output enable	Input
WE#	Write enable	Input
RP#	Reset/Block temporary unprotect	Input
RY/BY#	Ready/Busy	Input
BYTE#	Byte/Word organization select	Input
DQ0-DQ7	Data input/outputs	I/O
DQ8-DQ14	Data input/outputs	I/O
DQ15A-1 (or DQ15)	Data input/output or address input (or data I/O)	I/O
V _{CC}	Supply voltage	Supply voltage
V _{pp} /WP#	Supply voltage for FAST PROGRAM (optional) or WRITE PROTECT command	Supply voltage
V _{SS}	Ground	-
NC	Not connected internally	-

Note: 1. V_{pp}/WP# may be left floating because it is internally connected to a pull-up resistor to enable PROGRAM/ERASE commands.



Table 3: Protection Granularity on the M29W640GH and M29W640GL

Block	KB/Kwords	Protection Block Group	(x8)	(x16)
0 to 3	4 x 64/32	Block level	000000h-03FFFFh ¹	000000h-01FFFFh ¹
4 to 7	4 x 64/32	Protection group	040000h-07FFFFh	020000h-03FFFFh
–	–	–	–	–
120 to 123	4 x 64/32	Protection group	780000h-7BFFFFh	3C0000h-3DFFFFh
124 to 127	4 x 64/32	Block level	7C0000h-7FFFFh	3E0000h-3FFFFh

Note: 1. Used as the extended block addresses in extended block mode.

Table 4: Protection Granularity on the M29W640GT

Block	KB/Kwords	Protection Block Group	(x8)	(x16)
0 to 3	4 x 64/32	Protection group	000000h-03FFFFh ¹	000000h-01FFFFh ¹
4 to 7	4 x 64/32	Protection group	040000h-07FFFFh	020000h-03FFFFh
–	–	–	–	–
120 to 123	4 x 64/32	Protection group	780000h-7BFFFFh	3C0000h-3DFFFFh
124 to 126	3 x 64/32	Protection group	7C0000h-7EFFFFh	3E0000h-3F7FFFh
127 to 134	8 x 8/4 ²	Block level	7F0000h-7FFFFh	3F8000h-3FFFFh

Notes: 1. Used as the extended block addresses in extended block mode.
2. Boot blocks.

Table 5: Protection Granularity on the M29W640GB

Block	KB/Kwords	Protection Block Group	(x8)	(x16)
0 to 7	8x 8/4 ¹	Block level	000000h-00FFFFh ²	000000h-007FFFh ²
8 to 10	3 x 64/32	Protection group	010000h-03FFFFh	008000h-01FFFFh
11 to 14	4 x 64/32	Protection group	040000h-07FFFFh	020000h-03FFFFh
–	–	–	–	–
127 to 130	4 x 64/32	Protection group	780000h-7BFFFFh	3C0000h-3DFFFFh
131 to 134	4 x 64/32	Protection group	7C0000h-7FFFFh	3E0000h-3FFFFh

Notes: 1. Boot blocks.
2. Used as the extended block addresses in extended block mode.

Signal Assignments

Figure 2: 48-Pin TSOP

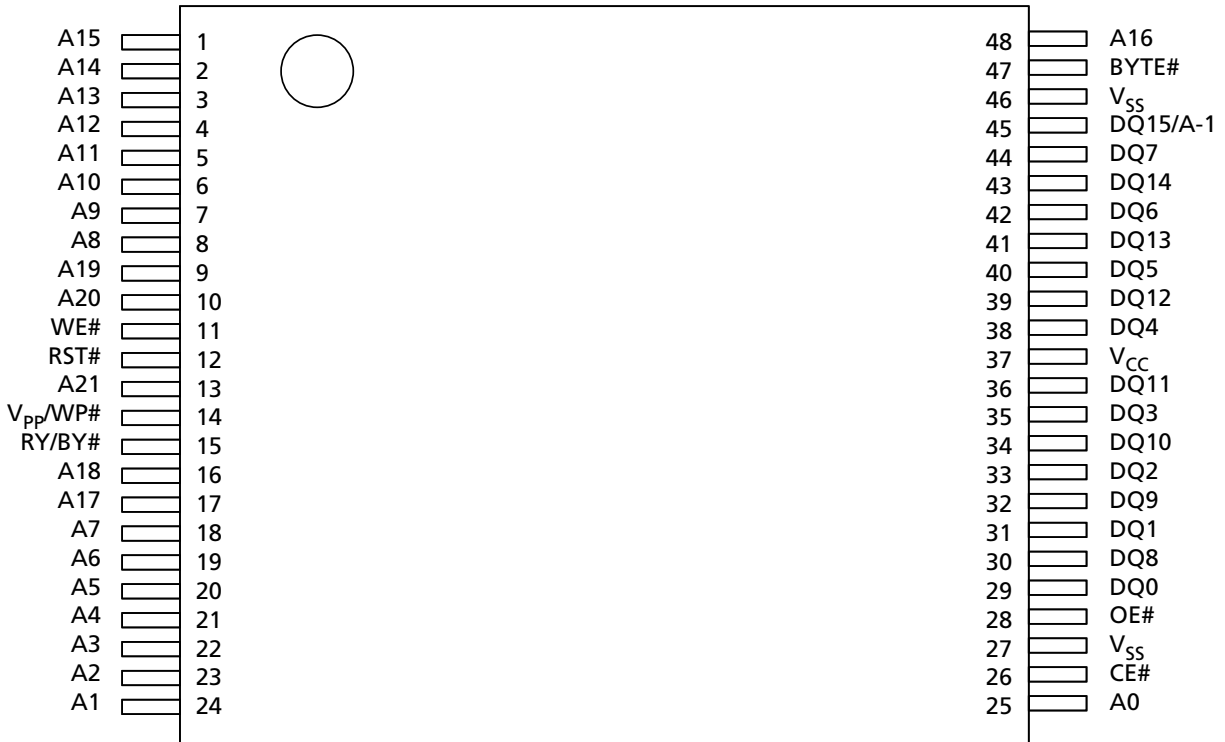

Note: 1. RFU = reserved for future use.

Figure 3: 56-Pin TSOP

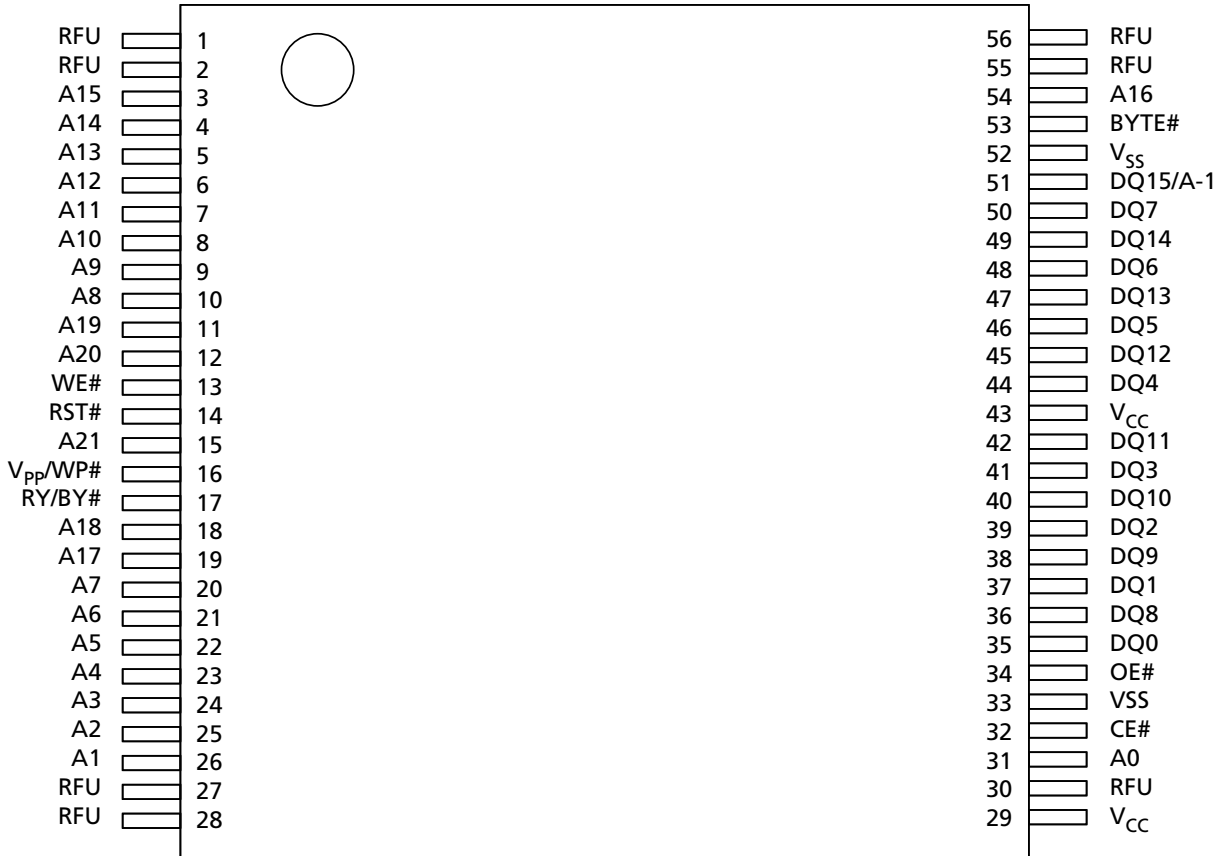

Note: 1. RFU = reserved for future use.

Figure 4: 48-Ball TFBGA

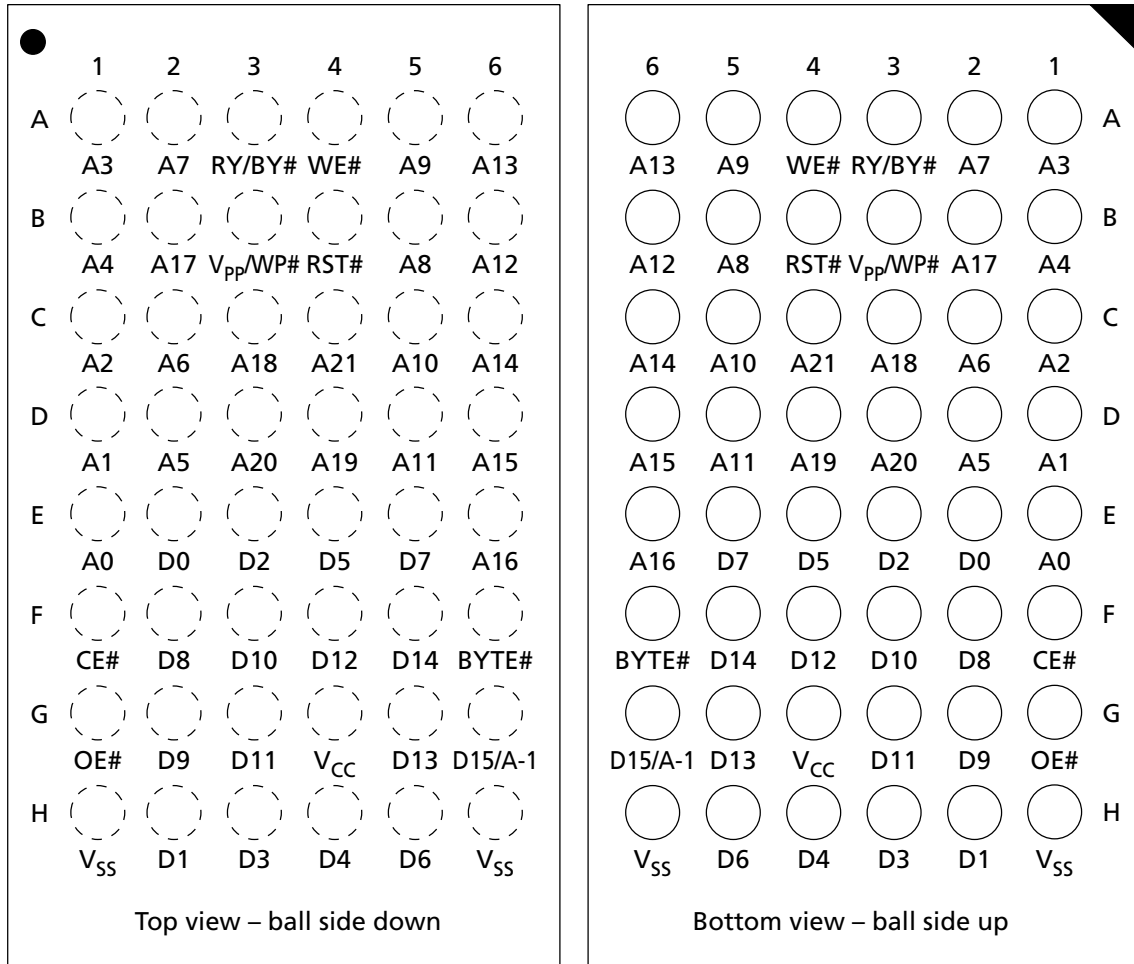

Note: 1. RFU = reserved for future use.

Figure 5: 64-Ball TFBGA

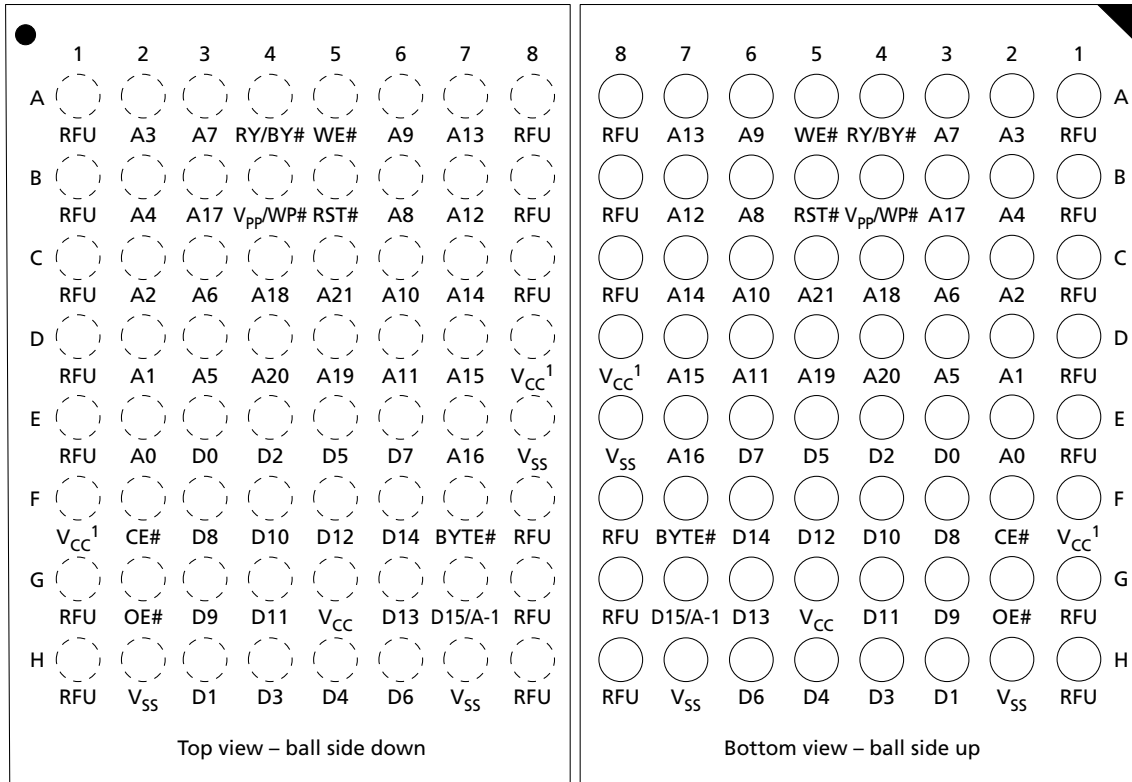

- Notes:
1. RFU = reserved for future use.
 2. Pads D8 and F1 are connected on the M29W640GT and M29W640GB devices.

Signal Descriptions

The following table is a comprehensive list of signals for this device family. All signals listed may not be supported on this device. See Signal Assignments for information specific to this device.

Table 6: Signal Descriptions

Name	Type	Description
A[MAX:0]	Input	Address: Select the cells in the memory array to access during bus READ operations. During bus WRITE operations they control the commands sent to the command interface of the program/erase controller.
CE#	Input	Chip enable: Activates the memory, allowing bus READ and bus WRTE operations to be performed. When CE# is HIGH, all other pins are ignored.
OE#	Input	Output enable: Controls the bus READ operation of the memory.
WE#	Input	Write enable: Controls the bus WRITE operation of the memory's command interface.
V _{pp} /WP#	Input	<p>V_{pp}/WP#: Provides two functions: V_{pp} enables the memory to use an external high-voltage power supply to reduce the time required for UNLOCK BYPASS PROGRAM operations. WP# performs hardware protection by protection the last block at the end of the addressable area (M29W640GH) or the first block at the beginning of the addressable area (M29W640GL). It protects the last two blocks at the end of the addressable area (M29W640GT) and the first two boot blocks at the beginning of the addressable area (M29W640GB).</p> <p>V_{pp}/WP# may be left floating or unconnected (see DC Characteristics). When V_{pp}/WP# is LOW, the last or first block in the M29W640GH and M29W640GL, respectively, and the last or first two blocks in the M29W640GT and M29W640GB, respectively, are protected. PROGRAM and ERASE operations in this block are ignored while V_{pp}/WP# is LOW, even when RST# is at V_{ID}.</p> <p>When V_{pp}/WP# is HIGH, V_{IH}, the device reverts to the previous protection status of the outermost blocks. PROGRAM and ERASE operations can now modify the data in the outermost blocks unless the block is protected using block protection.</p> <p>Applying 12V to V_{pp}/WP# will temporarily unprotect any block previously protected (including the outermost blocks) using a high-voltage block protection technique (in-system or programmer technique). (See Hardware Protection for details. When V_{pp}/WP# is raised to V_{pp}, the device automatically enters the unlock bypass mode. When V_{pp}/WP# returns to V_{IH} or V_{IL}, normal operation resumes. During UNLOCK BYPASS PROGRAM operations, the device draws I_{pp} from the pin to supply the programming circuits. (See UNLOCK BYPASS Command.) The transitions from V_{IH} to V_{pp} and from V_{pp} to V_{IH} must be slower than t_{VHVPP} (See the Accelerated Program Timing waveforms).</p> <p>Never raise V_{pp}/WP# to V_{pp} from any mode except read mode; otherwise, the device may be left in an indeterminate state.</p> <p>A 0.1µF capacitor should be connected between V_{pp}/WP# and the V_{SS} ground pin to decouple the current surges from the power supply. The PCB track widths must be sufficient to carry the currents required during an UNLOCK BYPASS PROGRAM operation, I_{pp}.</p>

Table 6: Signal Descriptions (Continued)

Name	Type	Description
DQ15/A-1	I/O	<p>Data I/O or address input: When HIGH, behaves as a data I/O pin (as DQ8–DQ14). When LOW, behaves as an address pin; DQ15A–1 LOW will select the LSB of the addressed word; DQ15A–1 HIGH will select the MSB.</p> <p>Throughout the text, consider references to the data I/O to include this pin when BYTE# is HIGH and references to the address inputs to include this pin when BYTE# is LOW, except when stated explicitly otherwise.</p>
RST#	Input	<p>Reset/Block temporary unprotect: Applies a hardware reset to the memory or temporarily unprotect all blocks that have been protected.</p> <p>Note that if V_{pp}/WP is at V_{IL}, then the last and the first block in the M29W640GH and M29W640GL, respectively, and the last two and first two blocks in the M29W640GT and M29W640GB, respectively, will remain protected, even if RST# is at V_{ID}.</p> <p>A hardware reset is achieved by holding RST# LOW for at least t_{PLPX}. After RST# goes HIGH, the memory will be ready for bus READ and bus WRITE operations after t_{PHEL} or t_{RHEL}, whichever occurs last. (See Reset Characteristics for more details.)</p> <p>Holding RST# at V_{ID} will temporarily unprotect the protected blocks in the memory. PROGRAM and ERASE operations on all blocks will be possible. The transition from V_{IH} to V_{ID} must be slower than t_{PHPHH}.</p>
DQ[14:8]	I/O	<p>Data I/O: Outputs the data stored at the selected address during a bus READ operation when BYTE# is HIGH. When BYTE# is LOW, these pins are not used and are High-Z. During bus WRITE operations, the command register does not use these bits. When reading the status register these bits should be ignored.</p>
DQ[7:0]	I/O	<p>Data I/O: Outputs the data stored at the selected address during a bus READ operation. During bus WRITE operations, they represent the commands sent to the command interface of the program/erase controller.</p>
RY/BY#	Output	<p>Ready busy: Open-drain output that identifies when the device is performing a PROGRAM or ERASE operation. During PROGRAM or ERASE operations, RY/BY# is LOW, and is High-Z during read mode, auto select mode, and erase suspend mode.</p> <p>After a hardware reset, bus READ and WRITE operations cannot begin until RY/BY# becomes High-Z. (See Reset Characteristics for more details.)</p> <p>The use of an open-drain output enables RY/BY# pins from several devices to be connected to a single pull-up resistor. A LOW will then indicate that one, or more, of the devices is busy.</p>
BYTE#	Input	<p>BYTE#/Word organization select: Switches between the x8 and x16 bus modes of the device. When LOW, the device is in x8 mode; when HIGH, it is in x16 mode.</p>

Table 6: Signal Descriptions (Continued)

Name	Type	Description
V _{CC}	Supply	<p>Supply voltage: Provides the power supply for all operations (READ, PROGRAM, and ERASE).</p> <p>The command interface is disabled when the V_{CC} supply voltage is less than the lockout voltage, V_{LKO}. This prevents bus WRITE operations from accidentally damaging the data during power-up, power-down, and power surges. If the program/erase controller is programming or erasing during this time, then the operation aborts and the memory contents being altered will be invalid.</p> <p>A 0.1 μF capacitor should be connected between the V_{CC} supply voltage pin and the V_{SS} ground pin to decouple the current surges from the power supply. The PCB track widths must be sufficient to carry the currents required during PROGRAM and ERASE operations, I_{CC3}.</p>
V _{SS}	Supply	<p>Ground: Reference for all voltage measurements. The device features two V_{SS} pins which must be both connected to the system ground.</p>
RFU	–	<p>Reserved for future use: RFUs should be not connected.</p>

Table 7: Hardware Protection

V _{pp} /WP#	RST#	Function	
V _{IL}	V _{IH}	M29W640GT and M29W640GB	Last 2 blocks at the end of the addressable area (M29W640GT) and first 2 blocks at the beginning of the addressable area (M29W640GB) protected from program/erase operations
		M29W640GH and M29W640GL	Last block at the end of the addressable area (M29W640GH) and first block at the beginning of the addressable area (M29W640GL) protected from program/erase operations
	V _{ID}	M29W640GT and M29W640GB	All blocks temporarily unprotected except the last 2 blocks at the end of the addressable area (M29W640GT) and first 2 blocks at the beginning of the addressable area (M29W640GB)
		M29W640GH and M29W640GL	All blocks temporarily unprotected except the last block at the end of the addressable area (M29W640GH) and first block at the beginning of the addressable area (M29W640GL)
V _{IH} or V _{ID}	V _{ID}	All blocks temporarily unprotected	
V _{PP}	V _{IH} or V _{ID}	All blocks temporarily unprotected	



Memory Organization

Memory Configuration

The memory array for M29W640GH and M29W640GL devices is organized into 128 uniform blocks of 64KB each for x8 and 32KW each for x16.

Uniform Block Memory Map, x16 – 64Mb Density

Table 8: x16 Uniform Blocks [127:0]

Block	Block Size	Address Range		Notes
		Start	End	
127	32KW	003F 8000	003F FFFF	
126	32KW	003F 0000	003F 7FFF	
125	32KW	003E 8000	003E FFFF	
124	32KW	003E 0000	003E 7FFF	
⋮	⋮	⋮	⋮	
3	32KW	0001 8000	0001 FFFF	1
2	32KW	0001 0000	0001 7FFF	
1	32KW	0000 8000	0000 FFFF	
0	32KW	0000 0000	0000 7FFF	

Note: 1. Used as the extended block addresses when the device is in extended block mode.

Uniform Block Memory Map, x8 – 64Mb Density

Table 9: x8 Uniform Blocks [127:0]

Block	Block Size	Address Range		Notes
		Start	End	
127	64KB	007F 0000	007F FFFF	
126	64KB	007E 0000	007E FFFF	
125	64KB	007D 0000	007D FFFF	
124	64KB	007C 0000	007C FFFF	
⋮	⋮	⋮	⋮	
3	64KB	0003 0000	0003 FFFF	1
2	64KB	0002 0000	0002 FFFF	
1	64KB	0001 0000	0001 FFFF	
0	64KB	0000 0000	0000 FFFF	

Note: 1. Used as the extended block addresses when the device is in extended block mode.

Bus Operations

Table 10: Bus Operations

Notes 1 and 2 apply to entire table

Operation	CE#	OE#	WE#	8-Bit Mode			16-Bit Mode	
				A[MAX:0], DQ15/A-1	DQ[14:8]	DQ[7:0]	A[MAX:0]	DQ15/A-1, DQ[14:0]
READ	L	L	H	Cell address	High-Z	Data output	Cell address	Data output
WRITE	L	H	L	Command address	High-Z	Data input ⁴	Command address	Data input ⁴
STANDBY	H	X	X	X	High-Z	High-Z	X	High-Z
OUTPUT DISABLE	X	H	H	X	High-Z	High-Z	X	High-Z

- Notes:
1. Typical glitches of less than 5ns on CE# and WE# are ignored by the device and do not affect bus operations.
 2. H = Logic level HIGH (V_{IH}); L = Logic level LOW (V_{IL}); X = HIGH or LOW.
 3. If WP# = LOW, the highest/lowest block remains protected, depending on the line item.
 4. Data input is required when issuing a command sequence or performing data polling or block protection.

Read

Bus READ operations read from the memory cells, registers, or CFI space. A valid READ operation requires setting the appropriate address on the address inputs, taking CE# and OE# LOW and holding WE# HIGH. Data I/O signals output the value.

Write

Bus WRITE operations write to the command interface. A valid WRITE operation requires setting the appropriate address on the address inputs. These are latched by the command interface on the falling edge of CE# or WE#, whichever occurs last. Values on data I/O signals are latched by the command interface on the rising edge of CE# or WE#, whichever occurs first. OE# must remain HIGH during the entire operation.

Standby and Automatic Standby

When the device is in read mode, driving CE# HIGH places the device in standby mode and drives data I/Os to High-Z. Supply current is reduced to standby (I_{CC2}), by holding CE# within $V_{CC} \pm 0.2V$.

During PROGRAM or ERASE operations, the device continues to use the program/erase supply current (I_{CC3}) until the operation completes.

Automatic standby enables low power consumption during read mode. When CMOS levels ($V_{CC} \pm 0.2V$) drive the bus, and following a READ operation and a period of inactivity specified in DC Characteristics, the memory enters automatic standby as internal supply current is reduced to I_{CC2} . Data I/O signals still output data if a READ operation is in progress.

Output Disable

Data I/Os are High-Z when OE# is HIGH.

Status Register

Bus READ operations from any address, always read the status register during PROGRAM and ERASE operations. It is also read during erase suspend when an address within a block being erased is accessed.

Data Polling Bit (DQ7)

The data polling bit can be used to identify whether the program/erase controller has successfully completed its operation or if it has responded to an erase suspend. The data polling bit is output on DQ7 when the status register is read.

During PROGRAM operations, DQ7 outputs the complement of the bit being programmed to DQ7. After successful completion of the PROGRAM operation, the memory returns to read mode and bus READ operations from the address just programmed output DQ7, not its complement.

During ERASE operations DQ7 outputs 0, the complement of the erased state of DQ7. After successful completion of the ERASE operation the memory returns to read mode.

In erase suspend mode, DQ7 will output a 1 during a bus READ operation within a block being erased. DQ7 will change from a 0 to a 1 when the program/erase controller has suspended the ERASE operation. The Data Polling Flowchart gives an example of how to use DQ7. A valid address is the address being programmed or an address within the block being erased.

Toggle Bit (DQ6)

The toggle bit can be used to identify whether the program/erase controller has successfully completed its operation or if it has responded to an erase suspend. The toggle bit is output on DQ6 when the status register is read.

During PROGRAM and ERASE operations, DQ6 changes from 0 to 1 to 0, and so forth, with successive bus READ operations at any address. After successful completion of the operation, the memory returns to read mode.

During erase suspend mode, DQ6 will output when addressing a cell within a block being erased. DQ6 will stop toggling when the program/erase controller has suspended the ERASE operation.

The Data Toggle Flowchart gives an example of how to use DQ6 and the toggle and alternative toggle waveforms describe toggle bit timing.

Error Bit (DQ5)

The error bit can be used to identify errors detected by the program/erase controller. DQ5 is set to 1 when a PROGRAM, BLOCK ERASE, or CHIP ERASE operation fails to write the correct data to the memory. If DQ5 is set, a READ/RESET command must be issued before other commands are issued. The error bit is output on DQ5 when the status register is read.

Note that the PROGRAM command cannot change a bit set to 0 back to 1 and attempting to do so will set DQ5 to 1. A bus READ operation to that address will show the bit remains 0. One of the ERASE commands must be used to set all the bits in a block or in the whole memory from 0 to 1.

Erase Timer Bit (DQ3)

The erase timer bit can be used to identify the start of program/erase controller operation during a BLOCK ERASE command. After the program/erase controller starts erasing, DQ3 is set to 1. Before the program/erase controller starts, DQ3 is set to 0 and additional blocks to be erased may be written to the command interface. The erase timer bit is output on DQ3 when the status register is read.

Alternative Toggle Bit (DQ2)

The alternative toggle bit can be used to monitor the program/erase controller during ERASE operations. It is output on DQ2 when the status register is read.

During CHIP ERASE and BLOCK ERASE operations, DQ2 changes from 0 to 1 to 0, and so forth, with successive bus READ operations from addresses within the blocks being erased. A protected block is treated the same as a block not being erased. After the operation completes, the memory returns to read mode.

During erase suspend, DQ2 changes from 0 to 1 to 0, and so forth, with successive bus READ operations from addresses within the blocks being erased. Bus READ operations to addresses within blocks not being erased will output the memory cell data as if in read mode.

After an ERASE operation that causes DQ5 to be set, DQ2 can be used to identify which block or blocks have caused the error. DQ2 changes from 0 to 1 to 0, and so forth, with successive bus READ operations from addresses within blocks that have not erased correctly. DQ2 does not change if the addressed block has erased correctly.

Write to Buffer and Program Abort Bit (DQ1)

DQ1 is set to 1 when a WRITE TO BUFFER AND PROGRAM operation aborts. Otherwise, DQ1 is set to 0. The WRITE TO BUFFER AND PROGRAM ABORT AND RESET command must be issued to return the device to read mode (see Command Interface for more information).

Table 11: Status Register Bits

Operation	Address	DQ7	DQ6	DQ5	DQ3	DQ2	DQ1	RY/BY#
PROGRAM	Any address	DQ7#	Toggle	0	–	–	0	0
PROGRAM DURING ERASE SUSPEND	Any address	DQ7#	Toggle	0	–	–	–	0
WRITE TO BUFFER AND PROGRAM ABORT	Any address	DQ7#	Toggle	0	–	–	1	0
WRITE TO BUFFER AND PROGRAM	Any address	DQ7#	Toggle	0	–	–	0	0
PROGRAM ERROR	Any address	DQ7#	Toggle	1	–	–	–	High-Z
CHIP ERASE	Any address	0	Toggle	0	1	Toggle	–	0
BLOCK ERASE BEFORE TIMEOUT	Erasing block	0	Toggle	0	0	Toggle	–	0
	Non-erasing block	0	Toggle	0	0	No Toggle	–	0

Table 11: Status Register Bits (Continued)

Operation	Address	DQ7	DQ6	DQ5	DQ3	DQ2	DQ1	RY/BY#
BLOCK ERASE	Erasing block	0	Toggle	0	1	Toggle	–	0
	Non-erasing block	0	Toggle	0	1	No Toggle	–	0
ERASE SUSPEND	Erasing block	1	No Toggle	0	–	Toggle	–	High-Z
	Non-erasing block	Data read as normal					–	High-Z
ERASE ERROR	Good block address	0	Toggle	1	1	No Toggle	–	High-Z
	Faulty block address	0	Toggle	1	1	Toggle	–	High-Z

Note: 1. Unspecified data bits should be ignored.

Figure 6: Data Polling Flowchart

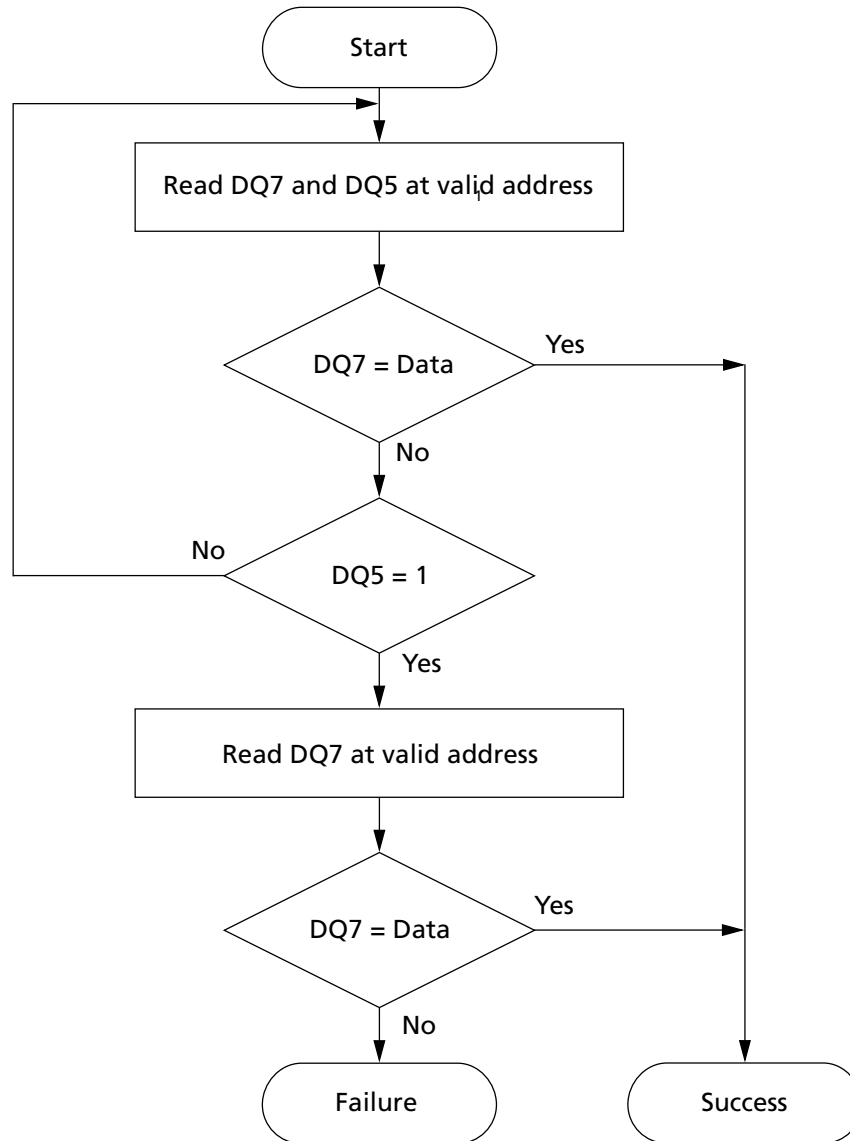
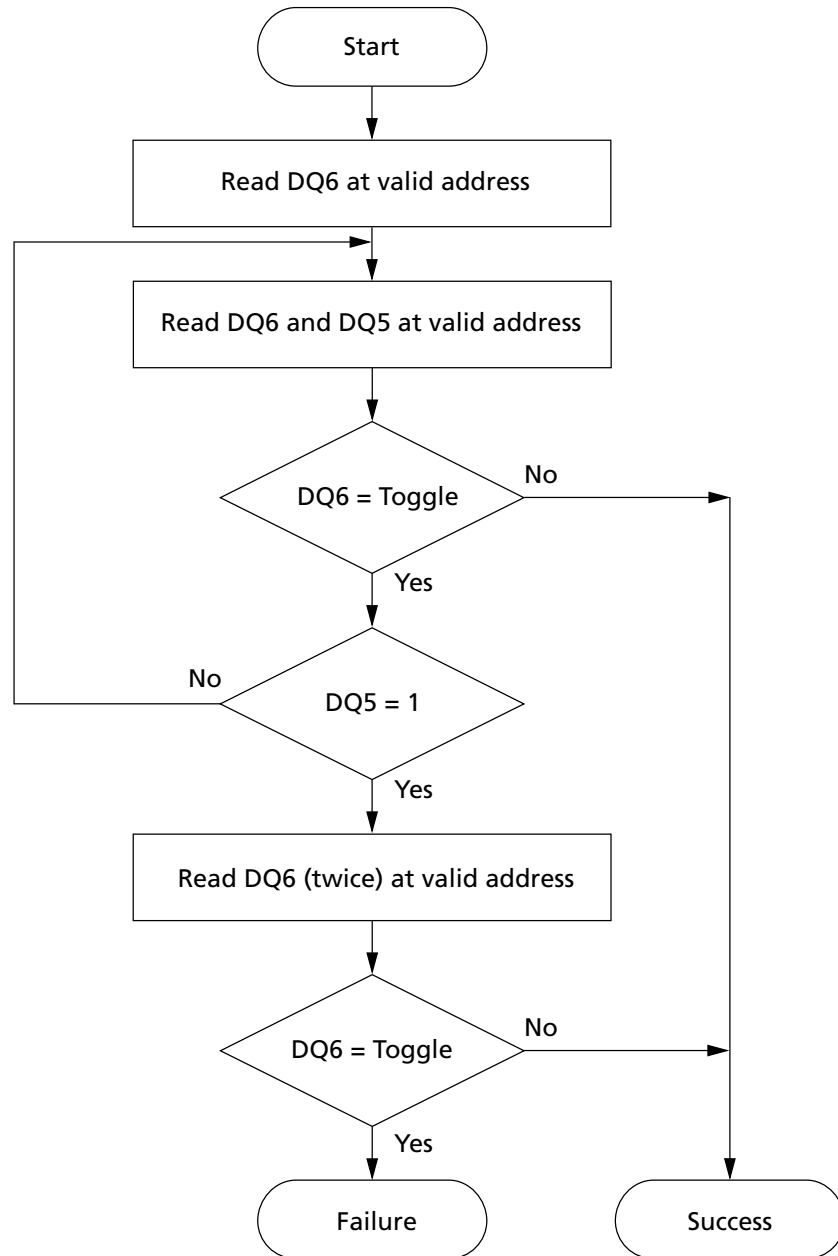

Figure 7: Data Toggle Flowchart



READ Operations

READ/RESET Command

The READ/RESET (F0h) command returns the device to read mode and resets the errors in the status register. One or three bus WRITE operations can be used to issue the READ/RESET command.

To return the device to read mode, this command can be issued between bus WRITE cycles before the start of a PROGRAM or ERASE operation. If the READ/RESET command is issued during the timeout of a BLOCK ERASE operation, the device requires up to 10 μ s to abort, during which time no valid data can be read.

READ CFI Command

The READ CFI (98h) command puts the device in read CFI mode and is valid only when the device is in read array or auto select mode. One bus WRITE cycle is required to issue the command.

Once in read CFI mode, bus READ operations will output data from the CFI memory area. A READ/RESET command must be issued to return the device to the previous mode (read array or auto select). A second READ/RESET command is required to put the device in read array mode from auto select mode.

AUTO SELECT Operations

AUTO SELECT Command

At power-up or after a hardware reset, the device is in read mode. It can then be put in auto select mode by issuing an AUTO SELECT (90h) command or by applying V_{ID} to A9. Auto select mode enables the following device information to be read:

- Electronic signature, which includes manufacturer and device code information.
- Block protection, which includes the block protection status and extended memory block protection indicator.

Electronic signature or block protection information is read by executing a READ operation with control signals and addresses set.

Auto select mode can be used by the programming equipment to automatically match a device with the application code to be programmed.

Three consecutive bus WRITE operations are required to issue an AUTO SELECT command. The device remains in auto select mode until a READ/RESET or READ CFI command is issued.

The device cannot enter auto select mode when a PROGRAM or ERASE operation is in progress (RY/BY# LOW). However, auto select mode can be entered if the PROGRAM or ERASE operation has been suspended by issuing a PROGRAM SUSPEND or ERASE SUSPEND command.

To enter auto select mode by applying V_{ID} to A9 (see the following tables).

Auto select mode is exited by performing a reset. The device returns to read mode unless it entered auto select mode after an ERASE SUSPEND or PROGRAM SUSPEND command, in which case it returns to erase or program suspend mode.

Table 12: Read Electronic Signature

Note 1 applies to entire table

Signal	READ Cycle						Notes
	Manufacturer Code	Device Code 1	Device Code 2		Device Code 3		
			GH/GL	GT/GB	GH/GT	GL/GB	
CE#	L	L	L	L	L	L	
OE#	L	L	L	L	L	L	
WE#	H	H	H	H	H	H	
Address Input, 8-Bit and 16-Bit							
A[MAX:10]	X	X	X	X	X	X	
A9	V_{ID}	V_{ID}	V_{ID}	V_{ID}	V_{ID}	V_{ID}	2
A8	X	X		X		X	
A[7:5]	L	L		L		L	
A4	X	X		X		X	
A[3:1]	L	L		H		H	
A0	L	H		L		H	
Address Input, 8-Bit Only							

Table 12: Read Electronic Signature (Continued)

Note 1 applies to entire table

Signal	READ Cycle						Notes
	Manufacturer Code	Device Code 1	Device Code 2		Device Code 3		
			GH/GL	GT/GB	GH/GT	GL/GB	
DQ[15]/A-1	X	X		X		X	
Data I/O, 8-Bit Only							
DQ[14:8]	X	X		X		X	
DQ[7:0]	20h	7Eh	0Ch	10h	01h	00h	
Data I/O, 16-Bit Only							
DQ[15]/A-1, and DQ[14:0]	0020h	227Eh	220Ch	2210h	2201h	2200h	

- Notes: 1. H = Logic level HIGH (V_{IH}); L = Logic level LOW (V_{IL}); X = HIGH or LOW.
 2. When using the AUTO SELECT command to enter auto select mode, applying V_{ID} to A9 is not required. A9 can be either V_{IL} or V_{IH} .

Table 13: Block Protection

Note 1 applies to entire table

Operation	CE#	OE#	WE #	Address Input											Data I/O DQ[15]/A-1, DQ[14:0]	
				A[MA X]	A15	A[14:1 3]	A12	A[11:1 0]	A9	A[8:7]	A6	A[5:4]	A[3: 2]	A1		A0
BLOCK PROTECT (Group)	L	V_{ID}	LP	Block address				X	V_{ID}	X					X	
CHIP UNPROTECT	V_{ID}	V_{ID}	LP	X	H	X	H	X	V_{ID}	X					X	
VERIFY BLOCK PROTECTION	L	L	H	Block address				X	V_{ID}	X	L	X	L	H	L	Pass = xx01h Retry = xx00h
VERIFY BLOCK UNPROTECT	L	L	H	Block address				X	V_{ID}	X	H	X	L	H	L	Retry = xx01h Pass = xx00h
READ BLOCK PROTECTION STATUS	L	L	H	Block address				X	V_{ID}	X	L	X	L	H	L	Protected (x8) = 01h Unprotected (x8) = 00h Protected (x16) = 0001h Unprotected (x16) = 0000h
GL, GT, GB																

Table 13: Block Protection (Continued)

Note 1 applies to entire table

Operation	CE#	OE#	WE#	Address Input										Data I/O		
				A[MA X]	A15	A[14:1 3]	A12	A[11:1 0]	A9	A[8:7]	A6	A[5:4]	A[3: 2]	A1	A0	DQ[15]/A-1, DQ[14:0]
READ EX- TENDED MEMORY BLOCK verify CODE	L	L	H	Block address				X	V _{ID}	X	L	X	L	H	H	Factory- locked = 98h Customer- lockable = 18h
GH																
READ EX- TENDED memory BLOCK verify CODE	L	L	H	Block address				X	V _{ID}	X	L	X	L	H	H	Factory- locked = 81h Customer- lockable = 01h

Note: 1. H = Logic level HIGH (V_{IH}); L = Logic level LOW (V_{IL}); X = HIGH or LOW.

Command Interface

All bus WRITE operations to the memory are interpreted by the command interface. Commands consist of one or more sequential bus WRITE operations. Failure to observe a valid sequence of bus WRITE operations will result in the memory returning to read mode. The long command sequences are imposed to maximize data security.

The address used for the commands changes depending on whether the memory is in 16-bit or 8-bit mode. See the x8 and x16 command tables, depending on the configuration that is being used, for a summary of the commands.

READ/RESET Command

The READ/RESET command returns the memory to its read mode. It also resets the errors in the status register. Either one or three bus WRITE operations can be used to issue the READ/RESET command.

The READ/RESET command can be issued, between bus WRITE cycles before the start of a PROGRAM or ERASE operation, to return the device to read mode. If the READ/RESET command is issued during the timeout of a BLOCK ERASE operation, then the device will take up to 10 μ s to abort. During the abort period, no valid data can be read from the device. The READ/RESET command will not abort an ERASE operation when issued while in erase suspend.

AUTO SELECT Command

The AUTO SELECT command is used to read the manufacturer code, the device code, the block protection status, and the extended memory block verify code. Three consecutive bus WRITE operations are required to issue the AUTO SELECT command. After the AUTO SELECT command is issued, the memory remains in auto select mode until a READ/RESET command is issued. READ CFI QUERY and READ/RESET commands are accepted in auto select mode, all other commands are ignored.

In auto select mode, the manufacturer code and the device code can be read by using a bus READ operation with addresses and control signals set, as shown Bus Operations, except for A9 (which is "Don't Care").

The block protection status of each block can be read using a bus READ operation with addresses and control signals set, as shown in Bus Operations, except for A9 (which is "Don't Care"). If the addressed block is protected, then 01h is output on DQ0–DQ7; otherwise, 00h is output (in 8-bit mode).

The protection status of the extended memory block, or extended memory block verify code, can be read using a bus READ operation with addresses and control signals, except for A9 (which is "Don't Care"). If the extended block is "factory-locked," then 80h is output on DQ0–DQ7; otherwise, 00h is output (8-bit mode).

READ CFI QUERY Command

The READ CFI QUERY command is used to read data from the CFI. This command is valid when the device is in the read array mode, or when the device is in auto select mode.

One bus WRITE cycle is required to issue the READ CFI QUERY command. After the command is issued, subsequent bus READ operations read from the CFI.

The READ/RESET command must be issued to return the device to the previous mode (the read array mode or auto select mode). A second READ/RESET command would be needed if the device is to be put in the read array mode from auto selected mode.

PROGRAM Command

The PROGRAM command can be used to program a value to one address in the memory array at a time. The command requires four bus WRITE operations; the final WRITE operation latches the address and data, and starts the program/erase controller.

Programming can be suspended and then resumed by issuing a PROGRAM SUSPEND command and a PROGRAM RESUME command, respectively.

If the address falls in a protected block, then the PROGRAM command is ignored, the data remains unchanged. The status register is never read and no error condition is given.

During a PROGRAM operation, the memory will ignore all commands. It is not possible to issue any command to abort or pause the operation. Bus READ operations during the PROGRAM operation will output the status register on the data I/Os. (See Status Register for more details.)

After the PROGRAM operation has completed, the memory will return to the read mode, unless an error has occurred. When an error occurs, the memory will continue to output the status register. A READ/RESET command must be issued to reset the error condition and return to read mode.

Note that the PROGRAM command cannot change a bit set to 0 back to 1. One of the ERASE commands must be used to set all the bits in a block or in the whole memory from 0 to 1. (Refer to Program/Erase Characteristics.)

PROGRAM SUSPEND Command

The PROGRAM SUSPEND command allows the system to interrupt a PROGRAM operation so that data can be read from any block. When the PROGRAM SUSPEND command is issued during a PROGRAM operation, the device suspends the PROGRAM operation within the program suspend latency time and updates the status register bits (see Program/Erase Characteristics).

After the PROGRAM operation has been suspended, the system can read array data from any address. However, data read from program-suspended addresses is not valid.

The PROGRAM SUSPEND command may also be issued during a PROGRAM operation while an erase is suspended. In this case, data may be read from any addresses not in ERASE SUSPEND or PROGRAM SUSPEND. If a read is needed from the extended block area (one-time program area), the user must use the proper command sequences to enter and exit this region.

The system may also issue the AUTO SELECT command sequence when the device is in the program suspend mode. The system can read as many auto select codes as required. When the device exits the auto select mode, the device reverts to the program suspend mode, and is ready for another valid operation.

PROGRAM RESUME Command

After the PROGRAM RESUME command is issued, the device reverts to programming. The controller can determine the status of the PROGRAM operation using the DQ7 or DQ6 status bits, just as in the standard PROGRAM operation.

The system must write the PROGRAM RESUME command, to exit the program suspend mode and to continue the programming operation.

Further issuing of the RESUME command is ignored. Another PROGRAM SUSPEND command can be written after the device has resumed programming.

Fast Program Commands

There are five fast program commands available to improve the programming throughput, by writing several adjacent words or bytes in parallel:

- QUADRUPLE and OCTUPLE BYTE PROGRAM, available for x8 operations
- DOUBLE and QUADRUPLE WORD PROGRAM, available for x16 operations
- WRITE TO BUFFER AND PROGRAM

Fast program commands can be suspended and then resumed by issuing a PROGRAM SUSPEND command and a PROGRAM RESUME command, respectively.

DOUBLE BYTE PROGRAM Command

The DOUBLE BYTE PROGRAM command is used to write a page of two adjacent bytes in parallel. The two bytes must differ only in DQ15A-1. Three bus WRITE cycles are necessary to issue the DOUBLE BYTE PROGRAM command:

The first bus cycle sets up the DOUBLE BYTE PROGRAM command; the second bus cycle latches the address and the data of the first byte to be written; and the third bus cycle latches the address and the data of the second byte to be written.

It is not necessary to raise $V_{pp}/WP\#$ to 12V before issuing this command.

QUADRUPLE BYTE PROGRAM Command

The QUADRUPLE BYTE PROGRAM command is used to write a page of four adjacent bytes in parallel. The four bytes must differ only for addresses A0, DQ15A-1. Five bus write cycles are necessary to issue the QUADRUPLE BYTE PROGRAM command:

The first bus cycle sets up the QUADRUPLE BYTE PROGRAM command; the second bus cycle latches the address and the data of the first byte to be written; the third bus cycle latches the address and the data of the second byte to be written; the fourth bus cycle latches the address and the data of the third byte to be written; and the fifth bus cycle latches the address and the data of the fourth byte to be written and starts the program/erase controller.

It is not necessary to raise $V_{pp}/WP\#$ to 12V before issuing this command.

OCTUPLE BYTE PROGRAM Command

This is used to write eight adjacent bytes, in x8 mode, simultaneously. The addresses of the eight bytes must differ only in A1, A0 and DQ15A-1.

12V must be applied to $V_{pp}/WP\#$ prior to issuing an OCTUPLE BYTE PROGRAM command. Care must be taken because applying a 12V voltage to $V_{pp}/WP\#$, because it will temporarily unprotect any protected block.

Nine bus WRITE cycles are necessary to issue the command:

The first bus cycle sets up the command; the second bus cycle latches the address and the data of the first byte to be written; the third bus cycle latches the address and the data of the second byte to be written; the fourth bus cycle latches the address and the data of the third byte to be written, the fifth bus cycle latches the address and the data of the fourth byte to be written; the sixth bus cycle latches the address and the data of the fifth byte to be written; the seventh bus cycle latches the address and the data of the sixth byte to be written; the eighth bus cycle latches the address and the data of the seventh byte to be written; and the ninth bus cycle latches the address and the data of the eighth byte to be written and starts the program/erase controller.

DOUBLE WORD PROGRAM Command

The DOUBLE WORD PROGRAM command is used to write a page of two adjacent words in parallel. The two words must differ only for the address A0.

Three bus WRITE cycles are necessary to issue the DOUBLE WORD PROGRAM command:

The first bus cycle sets up the DOUBLE WORD PROGRAM command; the second bus cycle latches the address and the data of the first word to be written; and the third bus cycle latches the address and the data of the second word to be written and starts the program/erase controller.

After the PROGRAM operation has completed, the memory will return to the read mode, unless an error has occurred. When an error occurs, bus READ operations will continue to output the status register. A READ/RESET command must be issued to reset the error condition and return to read mode.

Note that the fast program commands cannot change a bit set to 0 back to 1. One of the ERASE commands must be used to set all the bits in a block or in the whole memory from 0 to 1.

Typical program times are given in Program/Erase Characteristics.

Note:

It is not necessary to raise $V_{pp}/WP\#$ to 12V before issuing this command.

QUADRUPLE WORD PROGRAM Command

This is used to write a page of four adjacent words (or 8 adjacent bytes), in x16 mode, simultaneously. The addresses of the four words must differ only in A1 and A0.

12V must be applied to $V_{pp}/WP\#$ prior to issuing a QUADRUPLE BYTE PROGRAM command. Care must be taken because applying a 12V voltage to $V_{pp}/WP\#$, because it will temporarily unprotect any protected block.

Five bus WRITE cycles are necessary to issue the command:

The first bus cycle sets up the command; the second bus cycle latches the address and the data of the first word to be written; the third bus cycle latches the address and the data of the second word to be written; the fourth bus cycle latches the address and the

data of the third word to be written; and the fifth bus cycle latches the address and the data of the fourth word to be written and starts the program/erase controller.

WRITE TO BUFFER AND PROGRAM Command

The WRITE TO BUFFER AND PROGRAM command makes use of the device's 32-byte write buffer to speed up programming. 16 words/32 bytes can be loaded into the write buffer. Each write buffer has the same A4–A22 addresses. The WRITE TO BUFFER AND PROGRAM command dramatically reduces system programming time compared to the standard nonbuffered PROGRAM command.

When issuing a WRITE TO BUFFER AND PROGRAM command, $V_{PP}/WP\#$ can be either held HIGH or raised to V_{PPH} .

Five successive steps are required to issue the WRITE TO BUFFER AND PROGRAM command: The WRITE TO BUFFER AND PROGRAM command starts with two UNLOCK cycles. The third bus WRITE cycle sets up the WRITE TO BUFFER AND PROGRAM command. The setup code can be addressed to any location within the targeted block. The fourth bus WRITE cycle sets up the number of words to be programmed. Value n is written to the same block address, where $n + 1$ is the number of words to be programmed. The value of $n + 1$ must not exceed the size of the write buffer or the operation will abort. The fifth cycle loads the first address and data to be programmed. The value of n bus WRITE cycles is used to load the address and data for each word into the write buffer. Addresses must lie within the range from the start address+1 to the start address + $n - 1$. Optimum performance is obtained when the start address corresponds to a 64-byte boundary. If the start address is not aligned to a 64-byte boundary, the total programming time is doubled.

All the addresses used in the WRITE TO BUFFER AND PROGRAM operation must lie within the same page. If an address is written several times during a WRITE TO BUFFER AND PROGRAM operation, the address/data counter will be decremented at each data load operation, and the data will be programmed to the last word loaded into the buffer. Invalid address combinations or failing to follow the correct sequence of bus WRITE cycles will abort the WRITE TO BUFFER AND PROGRAM operation.

DQ1, DQ5, DQ6, DQ7 can be used to monitor the device status during a WRITE TO BUFFER AND PROGRAM operation. It is possible to detect PROGRAM operation fails when changing programmed data from 0 to 1; that is, when reprogramming data in a portion of memory already programmed. The resulting data will be the logical OR between the previous value and the current value.

To program the content of the write buffer, this command must be followed by a WRITE TO BUFFER AND PROGRAM CONFIRM command.

A WRITE TO BUFFER AND PROGRAM ABORT AND RESET command must be issued to abort the WRITE TO BUFFER AND PROGRAM operation and reset the device in read mode.

The write buffer programming sequence can be aborted in the following ways:

- Load a value that is greater than the page buffer size during the number of locations to program step
- Write to an address in a block different than the one specified during the WRITE-BUFFER-LOAD command
- Write an address/data pair to a different write-buffer-page than the one selected by the starting address during the write buffer data loading stage of the operation

- Write data other than the CONFIRM command after the specified number of data load cycles.

The abort condition is indicated by $DQ1 = 1$, $DQ7 = \text{DATA\#}$ (for the last address location loaded), $DQ6 = \text{toggle}$, and $DQ5 = 0$. A WRITE TO BUFFER ABORT AND RESET command sequence must be written to reset the device for the next operation. Note that the full three-cycle WRITE TO BUFFER ABORT AND RESET command sequence is required when using write-buffer-programming features in unlock bypass mode.

WRITE TO BUFFER AND PROGRAM CONFIRM Command

The WRITE TO BUFFER AND PROGRAM CONFIRM command is used to confirm a WRITE TO BUFFER AND PROGRAM command and to program the $n + 1$ words loaded in the write buffer by this command.

WRITE TO BUFFER AND PROGRAM ABORT AND RESET Command

The WRITE TO BUFFER AND PROGRAM ABORT AND RESET command is used to reset the device after a WRITE TO BUFFER AND PROGRAM command has been aborted.

UNLOCK BYPASS Command

The UNLOCK BYPASS command is used in conjunction with the UNLOCK BYPASS PROGRAM command to program the memory faster than with the standard PROGRAM commands. When the cycle time to the device is long, considerable time saving can be made by using these commands. Three bus WRITE operations are required to issue the UNLOCK BYPASS command.

After the UNLOCK BYPASS command has been issued, the memory will only accept the UNLOCK BYPASS PROGRAM command and the UNLOCK BYPASS RESET command. The memory can be read as if in read mode.

When V_{pp} is applied to $V_{pp}/\text{WP\#}$, the memory automatically enters the unlock bypass mode and the UNLOCK BYPASS PROGRAM command can be issued immediately.

UNLOCK BYPASS PROGRAM Command

The UNLOCK BYPASS command is used in conjunction with the UNLOCK BYPASS PROGRAM command to program the memory. When the cycle time to the device is long, considerable time saving can be made by using these commands. Three bus WRITE operations are required to issue the UNLOCK BYPASS command.

After the UNLOCK BYPASS command has been issued, the memory will only accept the UNLOCK BYPASS PROGRAM command and the UNLOCK BYPASS RESET command. The memory can be read as if in read mode.

The memory offers accelerated PROGRAM operations through $V_{pp}/\text{WP\#}$. When the system asserts V_{pp} on $V_{pp}/\text{WP\#}$, the memory automatically enters the unlock bypass mode. The system may then write the two-cycle UNLOCK BYPASS PROGRAM command sequence. The memory uses the higher voltage on $V_{pp}/\text{WP\#}$ to accelerate the UNLOCK BYPASS PROGRAM operation.

Never raise $V_{pp}/\text{WP\#}$ to V_{pp} from any mode except read mode; otherwise, the memory may be left in an indeterminate state.

UNLOCK BYPASS RESET Command

The UNLOCK BYPASS RESET command can be used to return to read/reset mode from unlock bypass mode. Two bus WRITE operations are required to issue the UNLOCK BYPASS RESET command. A READ/RESET command does not exit from unlock bypass mode.

CHIP ERASE Command

The CHIP ERASE command can be used to erase the entire chip. Six bus WRITE operations are required to issue the CHIP ERASE command and start the program/erase controller.

If any blocks are protected, then these are ignored and all the other blocks are erased. If all of the blocks are protected the CHIP ERASE operation appears to start but will terminate within about 100 μ s, leaving the data unchanged. No error condition is given when protected blocks are ignored.

During the ERASE operation the memory will ignore all commands, including the ERASE SUSPEND command. It is not possible to issue any command to abort the operation. All bus READ operations during the CHIP ERASE operation will output the status register on the data I/Os.

After the CHIP ERASE operation has completed, the memory will return to the read mode, unless an error has occurred. When an error occurs the memory will continue to output the status register. A READ/RESET command must be issued to reset the error condition and return to read mode.

The CHIP ERASE command sets all of the bits in unprotected blocks of the memory to 1. All previous data is lost.

BLOCK ERASE Command

The BLOCK ERASE command can be used to erase a list of one or more blocks. Six bus WRITE operations are required to select the first block in the list. Each additional block in the list can be selected by repeating the sixth bus WRITE operation using the address of the additional block. The BLOCK ERASE operation starts the program/erase controller about 50 μ s after the last bus WRITE operation. After the program/erase controller starts, it is not possible to select any more blocks. Each additional block must therefore be selected within 50 μ s of the last block. The 50 μ s timer restarts when an additional block is selected. The status register can be read after the sixth bus WRITE operation. (See the status register section for details on how to identify whether the program/erase controller has started the BLOCK ERASE operation.)

If any selected blocks are protected, then these are ignored and all the other selected blocks are erased. If all of the selected blocks are protected, the BLOCK ERASE operation appears to start but will terminate within about 100 μ s, leaving the data unchanged. No error condition is given when protected blocks are ignored.

During the BLOCK ERASE operation, the memory will ignore all commands except the ERASE SUSPEND command. (Typical block erase times are given in the Program/Erase Characteristics.) All bus READ operations during the BLOCK ERASE operation will output the status register on the data I/Os.

After the BLOCK ERASE operation has completed, the memory will return to the read mode, unless an error has occurred. When an error occurs, the memory will continue to

output the status register. A READ/RESET command must be issued to reset the error condition and return to read mode.

The BLOCK ERASE command sets all of the bits in the unprotected selected blocks to 1. All previous data in the selected blocks is lost.

ERASE SUSPEND Command

The ERASE SUSPEND command may be used to temporarily suspend a BLOCK ERASE operation and return the memory to read mode. The command requires one bus WRITE operation.

The program/erase controller will suspend within the erase suspend latency time of the ERASE SUSPEND command being issued. After the program/erase controller has stopped, the memory will be set to read mode and the erase will be suspended. If the ERASE SUSPEND command is issued during the period when the memory is waiting for an additional block (before the program/erase controller starts), then the erase is suspended immediately and will start immediately when the ERASE RESUME command is issued. It is not possible to select any further blocks to erase after the ERASE RESUME.

During ERASE SUSPEND, it is possible to read and program cells in blocks that are not being erased; both READ and PROGRAM operations behave as normal on these blocks. If any attempt is made to program in a protected block or in the suspended block, then the PROGRAM command is ignored and the data remains unchanged. The status register is not read and no error condition is given. Reading from blocks that are being erased will output the status register.

It is also possible to issue the AUTO SELECT, READ CFI QUERY, and UNLOCK BYPASS commands during an ERASE SUSPEND. The READ/RESET command must be issued to return the device to read array mode before the RESUME command will be accepted.

ERASE RESUME Command

The ERASE RESUME command must be used to restart the program/erase controller after an erase suspend. The device must be in read array mode before the RESUME command will be accepted. An erase can be suspended and resumed more than once.

ENTER EXTENDED BLOCK Command

The device has an extra 256-byte block (extended block) that can only be accessed using the ENTER EXTENDED BLOCK command. Three bus WRITE cycles are required to issue the ENTER EXTENDED BLOCK command. After the command has been issued, the device enters extended block mode where all bus READ or WRITE operations to the boot block addresses access the extended block. The extended block (with the same address as the boot blocks) cannot be erased, and can be treated as OTP memory. In extended block mode, the boot blocks are not accessible.

The extended block can be protected; however, once protected, the protection cannot be undone.

EXIT EXTENDED BLOCK Command

The EXIT EXTENDED BLOCK command is used to exit from the extended block mode and return the device to read mode. Four bus WRITE operations are required to issue the command.

BLOCK PROTECT and CHIP UNPROTECT Commands

Groups of blocks can be protected against accidental program or erase. (See Memory Organization for the protection groups.) The whole chip can be unprotected to allow the data inside the blocks to be changed.

BLOCK PROTECT Command

Block protection can be used to prevent any operation from modifying the data stored in the Flash. Each block can be protected individually. Once protected, PROGRAM and ERASE operations on the block fail to change the data.

There are three techniques that can be used to control block protection. These are programmer technique, in-system technique, and temporary unprotect. Temporary unprotect is controlled by RST#.

Unlike the command interface of the program/erase controller, the techniques for protecting and unprotecting blocks change between different Flash memory suppliers. Care should be taken when changing drivers for one part to work on another.

Programmer Technique

The programmer technique uses high voltage levels (V^{ID}) on some of the bus pins. These cannot be achieved using a standard microprocessor bus; therefore, the technique is recommended only for use in programming equipment.

To protect a block, follow the steps in the following figure. To unprotect the whole chip, it is necessary to protect all of the blocks first, then all blocks can be unprotected at the same time. (See the Programmer Equipment Chip Protect Flowchart.)

The timing on these flowcharts is critical. Care should be taken to ensure that, where a pause is specified, it is followed as closely as possible. Do not abort the procedure before reaching the end. Chip unprotect can take several seconds and a user message should be provided to show that the operation is progressing.

Figure 8: Programmer Equipment Block Protect Flowchart

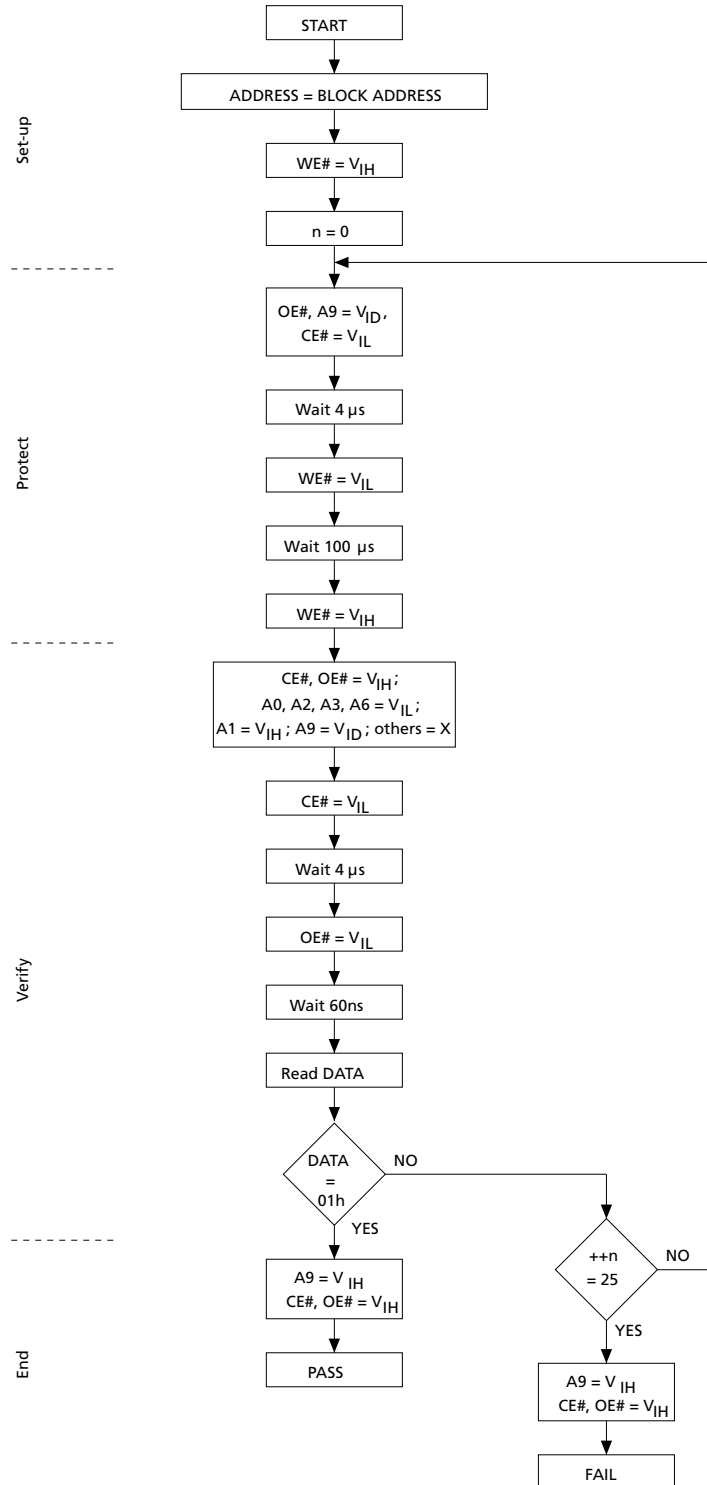

Figure 9: Programmer Equipment Chip Unprotect Flowchart

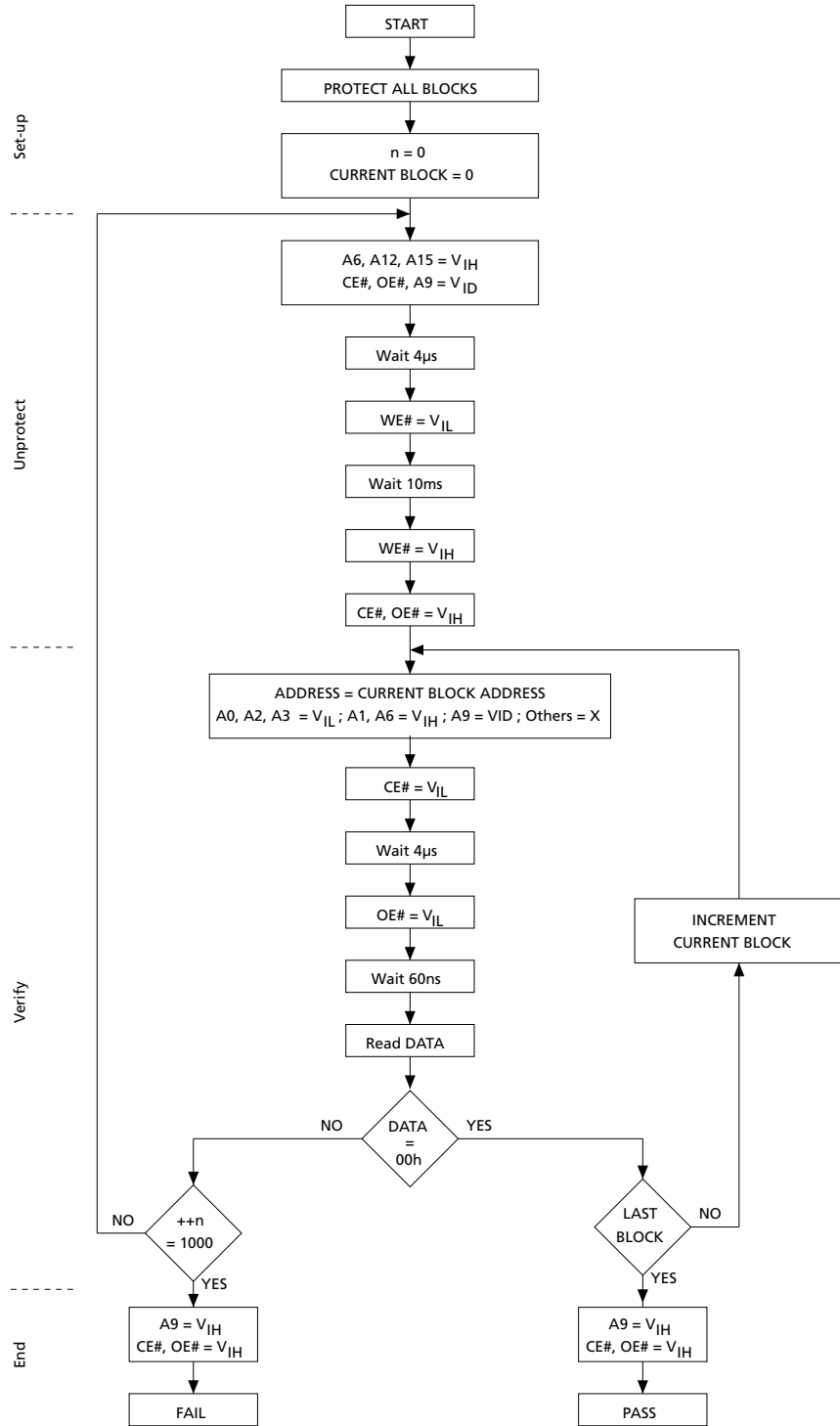

Table 14: Programmer Technique Bus Operations

Notes 1 and 2 apply to entire table

Operation	CE#	OE#	WE#	Address Inputs	Data I/Os
				A[MAX:0]	DQ15/A-1, DQ[14:0]
BLOCK PROTECT	L	V _{ID}	L pulse	A9 = V _{ID} A[21:12] block addresses others = X	X
CHIP UNPROTECT	V _{ID}	V _{ID}	L pulse	A9 = V _{ID} A12 = V _{IH} A15 = V _{IH} others = X	X
BLOCK PROTECTION VERIFY	L	L	V _{IH}	A0, A2, A3 = V _{IL} A1 = V _{IH} A6 = V _{IL} A9 = V _{ID} A[21:12] block addresses others = X	Pass = XX01h Retry = XX00h
BLOCK UNPROTECT VERIFY	L	L	V _{IH}	A0, A2, A3 = V _{IL} A1 = V _{IH} A6 = V _{IH} A9 = V _{ID} A[21:12] block addresses others = X	Retry = XX01h Pass = XX00h

- Notes:
1. Typical glitches of less than 5ns on CE# and WE# are ignored by the device and do not affect bus operations.
 2. H = Logic level HIGH (V_{IH}); L = Logic level LOW (V_{IL}); X = HIGH or LOW.

In-System Technique

The in-system technique requires a high-voltage level on RST#. This can be achieved without violating the maximum ratings of the components on the microprocessor bus; therefore, this technique is suitable for use after the Flash has been fitted to the system.

To protect a block, follow the steps in the following figure. To unprotect the whole chip, it is necessary to protect all of the blocks first, then all the blocks can be unprotected at the same time. (See the In-System Equipment Chip Unprotect Flowchart.)

The timing on these flowcharts is critical. Care should be taken to ensure that, where a pause is specified, it is followed as closely as possible. Do not allow the microprocessor to service interrupts that will upset the timing and do not abort the procedure before reaching the end. Chip unprotect can take several seconds and a user message should be provided to show that the operation is progressing.

Figure 10: In-System Equipment Block Protect Flowchart

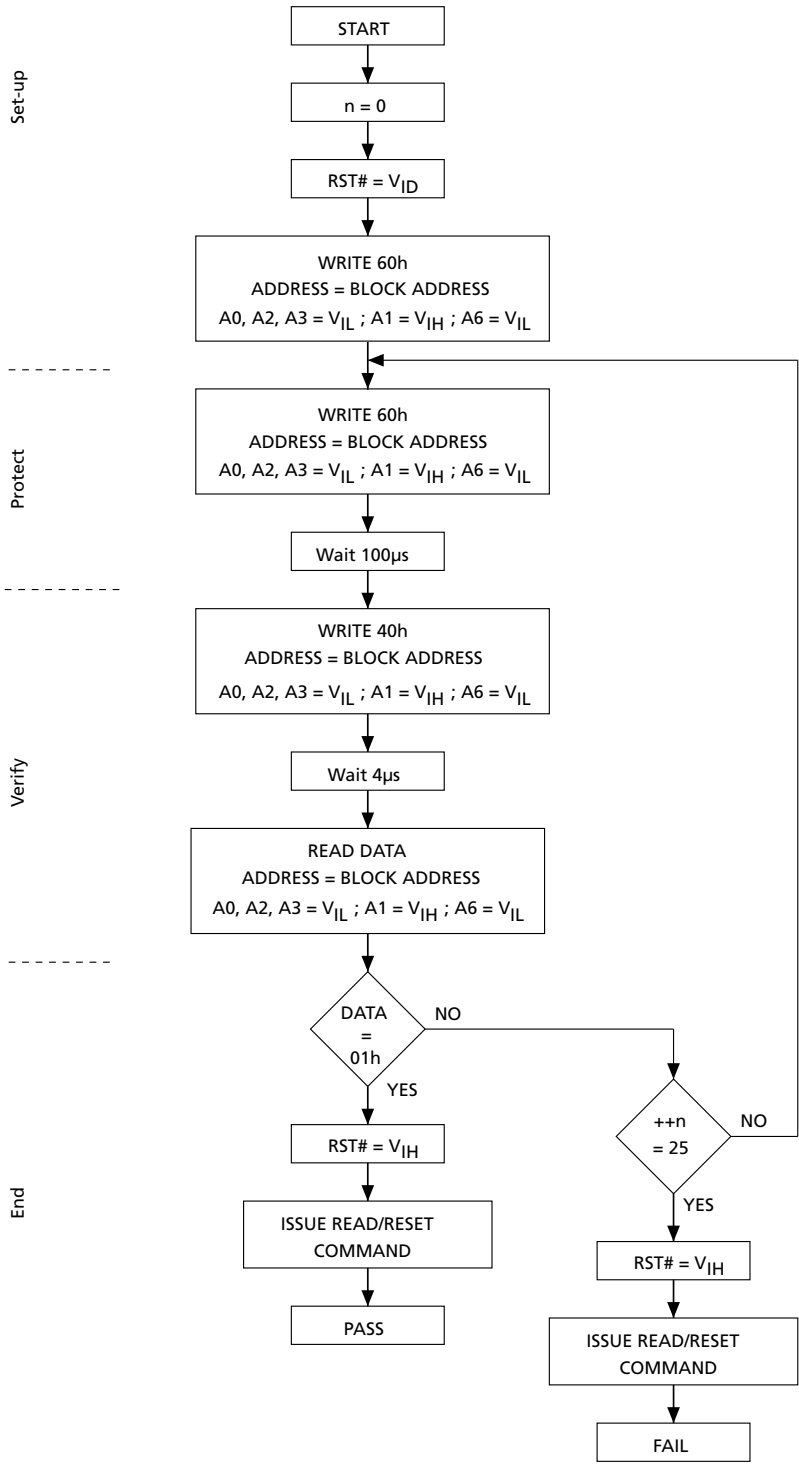

Figure 11: In-System Equipment Chip Protect Flowchart

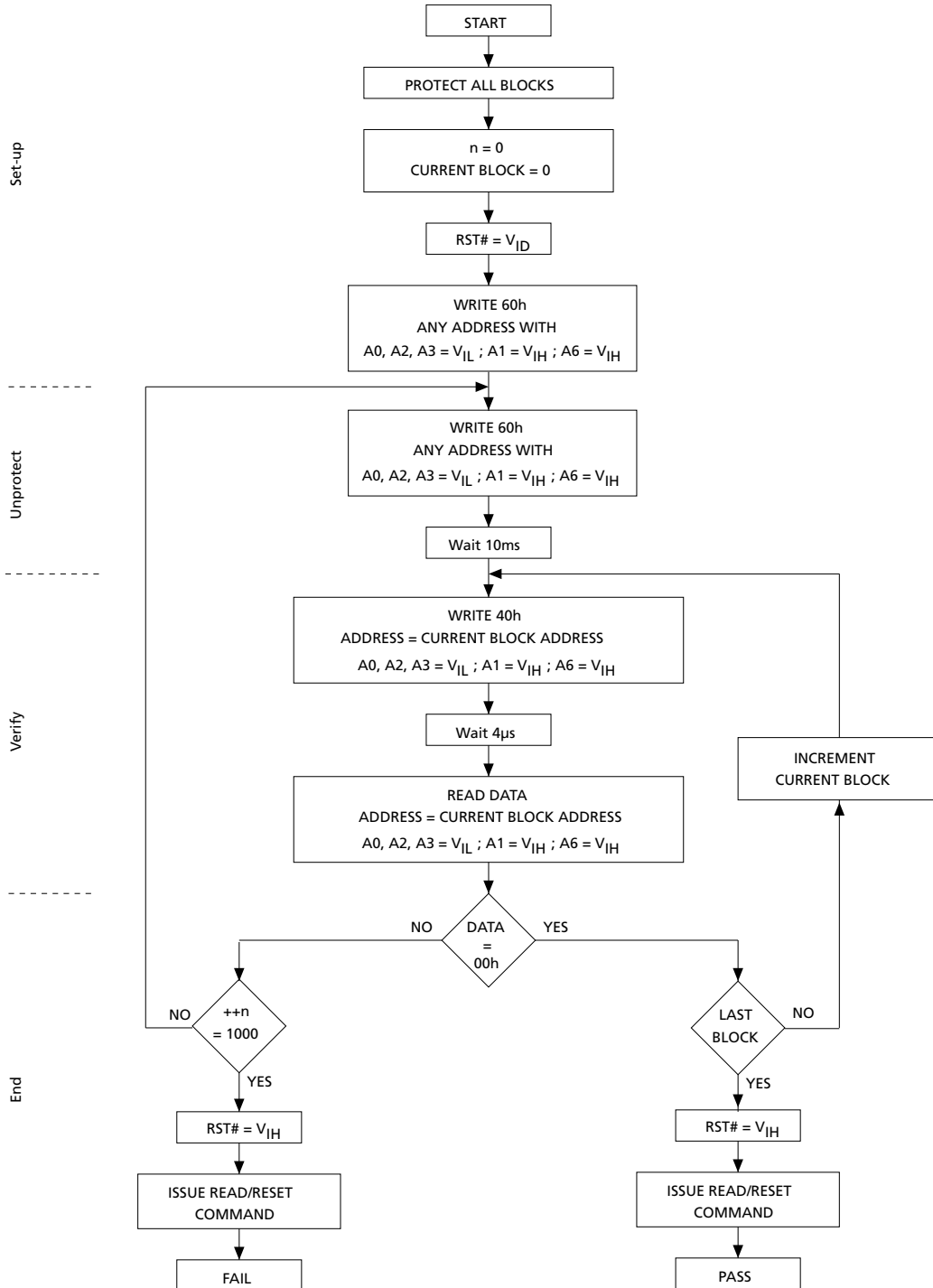

Table 15: Commands – 16-Bit Mode (BYTE# = V_{IH})

Command	Length	Bus WRITE Operations											
		1st		2nd		3rd		4th		5th		6th	
		Addr	Data	Addr	Data	Addr	Data	Addr	Data	Addr	Data	Addr	Data
READ/RESET	1	X	F0										
	3	555	AA	2AA	55	X	F0						
AUTO SELECT	3	555	AA	2AA	55	555	90						
READ CFI QUERY	1	55	98										
PROGRAM	4	555	AA	2AA	55	555	A0	PA	PD				
DOUBLE WORD PROGRAM	3	555	50	PA0	PD0	PA1	PD1						
QUADRUPLE WORD PROGRAM	5	555	56	PA0	PD0	PA1	PD1	PA2	PD2	PA3	PD3		
UNLOCK BY-PASS	3	555	AA	2AA	55	555	20						
UNLOCK BY-PASS PROGRAM	2	X	A0	PA	PD								
UNLOCK BY-PASS RESET	2	X	90	X	00								
WRITE TO BUFFER AND PROGRAM	N + 5	555	AA	2AA	55	BA	25	BA	N ^{on} page	PA ^{on} page	PD	WBL on page	PD
WRITE TO BUFFER AND PROGRAM ABORT AND RESET	3	555	AA	2AA	55	555	F0						
WRITE TO BUFFER AND PROGRAM CONFIRM	1	BA ^{on} page	29										
CHIP ERASE	6	555	AA	2AA	55	555	80	555	AA	2AA	55	555	10
BLOCK ERASE	6+	555	AA	2AA	55	555	80	555	AA	2AA	55	BA	30
PROGRAM/ERASE SUSPEND	1	X	B0										
PROGRAM/ERASE RESUME	1	X	30										
ENTER EXTENDED BLOCK	3	555	AA	2AA	55	555	88						

Table 15: Commands – 16-Bit Mode (BYTE# = V_{IH}) (Continued)

Command	Length	Bus WRITE Operations											
		1st		2nd		3rd		4th		5th		6th	
		Addr	Data	Addr	Data	Addr	Data	Addr	Data	Addr	Data	Addr	Data
EXIT EXTENDED BLOCK	4	555	AA	2AA	55	555	90	X	00				

- Notes:
1. X = " Don't Care;" PA = Program address; PD = Program data; BA = Any address in the block. All values in the table are in hexadecimal. The command interface only uses A-1; A0–A10 and DQ0–DQ7 to verify the commands; A11–A20, DQ8–DQ14 and DQ15 are "Don't Care." DQ15A-1 is A-1 when BYTE# is V_{IL} or DQ15 when BYTE# is V_{IH}.
 2. The maximum number of cycles in the command sequence is 36. N + 1 is the number of words to be programmed during the WRITE TO BUFFER AND PROGRAM operation.
 3. Each buffer has the same A4–A22 addresses. A0–A3 are used to select a word within the N + 1 word page.
 4. The 6th cycle has to be issued N time. WBL scans the word inside the page.
 5. BA must be identical to the address loaded during the WRITE TO BUFFER AND PROGRAM 3rd and 4th cycles.

Table 16: Commands – 8-Bit Mode (BYTE# = V_{IL})

Command	Length	Bus WRITE Operations											
		1st		2nd		3rd		4th		5th		6th	
		Addr	Data	Addr	Data	Addr	Data	Addr	Data	Addr	Data	Addr	Data
READ/RESET	1	X	F0										
	3	AAA	AA	555	55	X	F0						
AUTO SELECT	3	AAA	AA	555	55	AAA	90						
READ CFI QUERY	1	AA	98										
PROGRAM	4	AAA	AA	555	55	AAA	A0	PA	PD				
DOUBLE BYTE PROGRAM	3	AAA	50	PA0	PD0	PA1	PD1						
QUADRUPLE BYTE PROGRAM	5	AAA	56	PA0	PD0	PA1	PD1	PA2	PD2	PA3	PD3		
OCTUPLE BYTE PROGRAM	9	AAA	8B	PA0	PD0	PA1	PD1	PA2	PD2	PA3	PD3	PA4	PD4 ²
WRITE TO BUFFER AND PROGRAM	N + 5	AAA	AA	555	55	BA	25	BA	N ²	PA ⁴	PD	WBL ⁵	PD
WRITE TO BUFFER AND PROGRAM ABORT AND RESET	3	AAA	AA	555	55	AAA	F0						
WRITE TO BUFFER AND PROGRAM CONFIRM	1	BA ⁶	29										
UNLOCK BY-PASS	3	AAA	AA	555	55	AAA	20						
UNLOCK BY-PASS PROGRAM	2	X	A0	PA	PD								
UNLOCK BY-PASS RESET	2	X	90	X	00								
CHIP ERASE	6	AAA	AA	555	55	AAA	80	AAA	AA	555	55	AAA	10
BLOCK ERASE	6+	AAA	AA	555	55	AAA	80	AAA	AA	555	55	BA	30
PROGRAM/ERASE SUSPEND	1	X	B0										
PROGRAM/ERASE RESUME	1	X	30										

Table 16: Commands – 8-Bit Mode (BYTE# = V_{IL}) (Continued)

Command	Length	Bus WRITE Operations											
		1st		2nd		3rd		4th		5th		6th	
		Addr	Data	Addr	Data	Addr	Data	Addr	Data	Addr	Data	Addr	Data
ENTER EXTENDED BLOCK	3	AAA	AA	555	55	AAA	88						
EXIT EXTENDED BLOCK	4	AAA	AA	555	55	AAA	90	X	00				

- Notes:
1. X = " Don't Care;" PA = Program address; PD = Program data; BA = Any address in the block. All values in the table are in hexadecimal. The command interface only uses A-1, A0-A10, and DQ0-DQ7 to verify the commands; A11-A20, DQ8-DQ14, and DQ15 are "Don't Care." DQ15A-1 is A-1 when BYTE# is V_{IL} or DQ15 when BYTE# is V_{IH}.
 2. The following is content for address: Data cycles 7 through 10: PA5-PD5, PA6-PD6, PA7-PD7, PA8-PD8.
 3. The maximum number of cycles in the command sequence is 68. N + 1 is the number of words to be programmed during the WRITE TO BUFFER AND PROGRAM operation.
 4. Each buffer has the same A4-A22 addresses. A0-A3 and DQ15A-1 are used to select a word within the N + 1 word page.
 5. The 6th cycle has to be issued N time. WBL scans the word inside the page.
 6. BA must be identical to the address loaded during the WRITE TO BUFFER AND PROGRAM 3rd and 4th cycles.

Common Flash Interface

The common Flash interface (CFI) is a JEDEC-approved, standardized data structure that can be read from the Flash memory device. It allows a system's software to query the device to determine various electrical and timing parameters, density information, and functions supported by the memory. The system can interface easily with the device, enabling the software to upgrade itself when necessary.

When the READ CFI command is issued, the device enters CFI query mode and the data structure is read from memory. The following tables show the addresses (A-1, A[7:0]) used to retrieve the data. The query data is always presented on the lowest order data outputs (DQ[7:0]), and the other data outputs (DQ[15:8]) are set to 0.

Table 17: Query Structure Overview

Note 1 applies to the entire table

Address		Subsection Name	Description
x16	x8		
10h	20h	CFI query identification string	Command set ID and algorithm data offset
1Bh	36h	System interface information	Device timing and voltage information
27h	4Eh	Device geometry definition	Flash device layout
40h	80h	Primary algorithm-specific extended query table	Additional information specific to the primary algorithm (optional)
61h	C2h	Security code area	64-bit unique device number

Note: 1. Query data are always presented on the lowest order data outputs (DQ[7:0]). DQ[15:8] are set to 0.

Table 18: CFI Query Identification String

Note 1 applies to the entire table

Address		Data	Description	Value
x16	x8			
10h	20h	0051h	Query unique ASCII string "QRY"	"Q"
11h	22h	0052h		"R"
12h	24h	0059h		"Y"
13h	26h	0002h	Primary algorithm command set and control interface ID code 16-bit ID code defining a specific algorithm	AMD compatible
14h	28h	0000h		
15h	2Ah	0040h	Address for primary algorithm extended query table (see the Primary Algorithm-Specific Extended Query Table)	P = 40h
16h	2Ch	0000h		
17h	2Eh	0000h	Alternate vendor command set and control interface ID code second vendor-specified algorithm supported	-
18h	30h	0000h		
19h	32h	0000h	Address for alternate algorithm extended query table	-
1Ah	34h	0000h		

Note: 1. Query data are always presented on the lowest order data outputs (DQ[7:0]). DQ[15:8] are set to 0.

Table 19: CFI Query System Interface Information

Note 1 applies to the entire table

Address		Data	Description	Value
x16	x8			
1Bh	36h	0027h	V _{CC} logic supply minimum program/erase voltage Bits[7:4] BCD value in volts Bits[3:0] BCD value in 100mV	2.7V
1Ch	38h	0036h	V _{CC} logic supply maximum program/erase voltage Bits[7:4] BCD value in volts Bits[3:0] BCD value in 100mV	3.6V
1Dh	3Ah	00B5h	V _{PPH} (programming) supply minimum program/erase voltage Bits[7:4] hex value in volts Bits[3:0] BCD value in 100mV	11.5V
1Eh	3Ch	00C5h	V _{PPH} (programming) supply maximum program/erase voltage Bits[7:4] hex value in volts Bits[3:0] BCD value in 100mV	12.5V
1Fh	3Eh	0004h	Typical timeout for single byte/word program = 2 ⁿ μs	16μs
20h	40h	0004h	Typical timeout for maximum size buffer program = 2 ⁿ μs	16μs
21h	42h	000Ah	Typical timeout per individual block erase = 2 ⁿ ms	1s
22h	44h	0000h	Typical timeout for full chip erase = 2 ⁿ ms	–
23h	46h	0004h	Maximum timeout for byte/word program = 2 ⁿ times typical	256μs
24h	48h	0004h	Maximum timeout for buffer program = 2 ⁿ times typical	200μs
25h	4Ah	0003h	Maximum timeout per individual block erase = 2 ⁿ times typical	8s
26h	4Ch	0000h	Maximum timeout for chip erase = 2 ⁿ times typical	–

Note: 1. The values in this table are valid for both packages.

Table 20: Device Geometry Definition

Address		Data	Description	Value
x16	x8			
27h	4Eh	0017h	Device size = 2 ⁿ in number of bytes	8MB
28h	50h	0002h	Flash device interface code description	x8, x16 asynchronous
29h	52h	0000h		
2Ah	54h	0005h	Maximum number of bytes in multi-byte program or page = 2 ⁿ	32
2Bh	56h	0000h		
2Ch	58h	0001h	Number of erase block regions. It specifies the number of regions containing contiguous erase blocks of the same size. M29W640GH and M29W640GL devices only	1
		0002h	Number of erase block regions. It specifies the number of regions containing contiguous erase blocks of the same size. M29W640GT and M29W640GB devices only	2
2Dh	5Ah	0007h	Region 1 information	128
2Eh	5Ch	0000h	Number of identical-size erase blocks = 007Fh + 1 M29W640GH and M29W640GL devices only	

Table 20: Device Geometry Definition (Continued)

Address		Data	Description	Value
x16	x8			
2Fh 30h	5Eh 60h	0000h 0000h	Region 1 information Block size in region 1 = 0100h × 256 bytes M29W640GH and M29W640GL devices only	64KB
2Dh 2Eh	5Ah 5Ch	0007h 0000h	Region 1 information Number of identical-size erase blocks = 0007h + 1 M29W640GT and M29W640GB devices only	8
2Fh 30h	5Eh 60h	0020h 0000h	Region 1 information Block size in region 1 = 0200h × 256 bytes M29W640GT and M29W640GB devices only	8KB
31h 32h	62h 64h	007Eh 0000h	Region 2 information Number of identical-size erase blocks = 007Eh + 1 M29W640GT and M29W640GB devices only	127
33h 34h	66h 68h	0000h 0001h	Region 2 information Block size in region 2 = 0100h × 256 bytes M29W640GT and M29W640GB devices only	64KB
35h 36h 37h 38h	6Ah 6Ch 6Eh 70h	0000h 0000h 0000h 0000h	Region 3 information Number of identical-size erase blocks = 0000h + 1 Region 3 information Block size in region 3 = 0000h × 256 bytes M29W640GT and M29W640GB devices only	0
39h 3Ah 3Bh 3Ch	72h 74h 76h 78h	0000h 0000h 0000h 0000h	Region 4 information Number of identical-size erase blocks = 0000h + 1 Region 4 information Block size in region 4 = 0000h × 256 bytes M29W640GT and M29W640GB devices only	0

Note: 1. For bottom boot devices, erase block region 1 is located from address 000000h to 007FFFh and erase block region 2 from address 008000h to 3FFFFFFh. For top boot devices, erase block region 1 is located from address 000000h to 3F7FFFh and erase block region 2 from address 3F8000h to 3FFFFFFh.

Table 21: Primary Algorithm-Specific Extended Query Table

Note 1 applies to the entire table

Address		Data	Description	Value
x16	x8			
40h	80h	0050h	Primary algorithm extended query table unique ASCII string "PRI"	"P"
41h	82h	0052h		"R"
42h	84h	0049h		"I"
43h	86h	0031h	Major version number, ASCII	"1"
44h	88h	0033h	Minor version number, ASCII	"3"

Table 21: Primary Algorithm-Specific Extended Query Table (Continued)

Note 1 applies to the entire table

Address		Data	Description	Value
x16	x8			
45h	8Ah	0000h	Address sensitive unlock (bits[1:0]): 00 = Required 01 = Not required Silicon revision number (bits[7:2])	00
46h	8Ch	0002h	Erase suspend: 00 = Not supported 01 = Read only 02 = Read and write	2
47h	8Eh	0004h	Block protection: 00 = Not supported x = Number of blocks per group	4
48h	90h	0001h	Temporary block unprotect: 00 = Not supported 01 = Supported	01
49h	92h	0004h	Block protect/unprotect	04
4Ah	94h	0000h	Simultaneous operations: Not supported	–
4Bh	96h	0000h	Burst mode: 00 = Not supported 01 = Supported	00
4Ch	98h	0001h	Page mode: 00 = Not supported 01 = 4-word page; 02 = 8-word page	01
4Dh	9Ah	00B5h	V _{PPH} supply minimum program/erase voltage: Bits[7:4] hex value in volts Bits[3:0] BCD value in 100mV	11.5V
4Eh	9Ch	00C5h	V _{PPH} supply maximum program/erase voltage: Bits[7:4] hex value in volts Bits[3:0] BCD value in 100mV	12.5V
4Fh	9Eh	00xxh	Top/bottom boot block flag: xx = 02h: M29W640GB bottom boot device xx = 03h: M29W640GT top boot device xx = 04h: M29W640GL first block protected by V _{pp} /WP# xx = 05h: M29W640GH, last block protected by V _{pp} /WP#	Uniform + V _{pp} /WP# protect- ing highest or lowest block
50h	A0h	0001h	Program suspend: 00 = Not supported 01 = Supported	01

Note: 1. The values in this table are valid for both packages.

Table 22: Security Code Area

Address		Data	Description
x16	x8		
61h	C3h, C2h	XXXX	64-bit unique device number
62h	C5h, C4h	XXXX	
63h	C7h, C6h	XXXX	
64h	C9h, C8h	XXXX	

Absolute Ratings and Operating Conditions

Stresses greater than those listed may cause permanent damage to the device. This is a stress rating only, and functional operation of the device at these or any other conditions outside those indicated in the operational sections of this specification is not implied. Exposure to absolute maximum rating conditions for extended periods may adversely affect reliability.

Table 23: Absolute Maximum/Minimum Ratings

Parameter	Symbol	Min	Max	Unit	Notes
Temperature under bias	T_{BIAS}	-50	125	°C	
Storage temperature	T_{STG}	-65	150	°C	
Input/output voltage	V_{IO}	-0.6	$V_{CC} + 0.6$	V	1, 2
Supply voltage	V_{CC}	-0.6	4	V	
Program voltage	V_{PP}	-0.6	13.5	V	3
Identification voltage	V_{ID}	-0.6	13.5	V	

- Notes:
1. During signal transitions, minimum voltage may undershoot to $-2V$ for periods less than 20ns.
 2. During signal transitions, maximum voltage may overshoot to $V_{CC} + 2V$ for periods less than 20ns.
 3. V_{PP} must not remain at 12V for more than a total of 80 hours.

Table 24: Operating Conditions

Parameter	Symbol	M29W640GT/B and M29W640GH/L		Unit	Notes
		Min	Max		
Supply voltage	V_{CC}	2.7	3.6	V	
Ambient operating temperature	T_A	-40	85/125	°C	1
Load capacitance	C_L	30		pF	
Input rise and fall times	–	–	10	ns	
Input pulse voltages	–	0 to V_{CC}		V	
Input and output timing reference voltages	–	$V_{CC}/2$		V	

- Note: 1. 85°C = industrial part; 125°C = autograde part.

Figure 12: AC Measurement Load Circuit

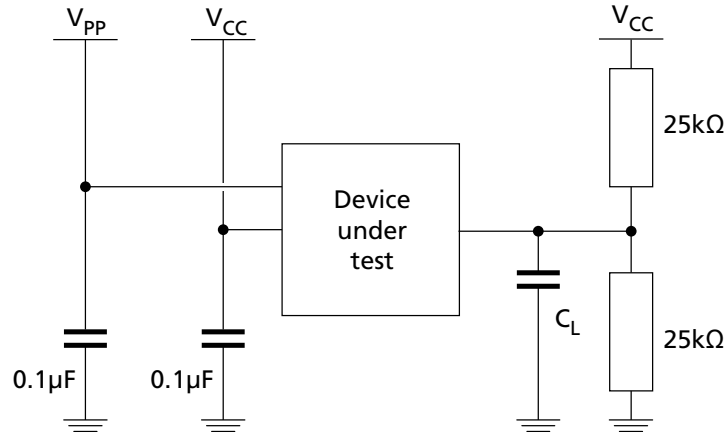

Note: 1. C_L includes jig capacitance.

Figure 13: AC Measurement I/O Waveform

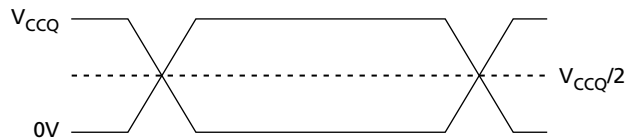

Table 25: Input/Output Capacitance

Parameter	Symbol	Test Condition	Min	Max	Unit
Input capacitance	C_{IN}	$V_{IN} = 0\text{V}$	–	6	pF
Output capacitance	C_{OUT}	$V_{OUT} = 0\text{V}$	–	12	pF

Note: 1. Sampled only, not 100% tested.

DC Characteristics

Table 26: DC Current Characteristics

Parameter	Symbol	Conditions	Typ	Max	Unit	Notes
Input leakage current	I_{LI}	$0V \leq V_{IN} \leq V_{CC}$	–	± 1	μA	1
Output leakage current	I_{LO}	$0V \leq V_{OUT} \leq V_{CC}$	–	± 1	μA	
Read current	I_{CC1}	$CE\# = V_{IL}$, $OE\# = V_{IH}$, $f = 6 \text{ MHz}$		10	mA	
Standby current	I_{CC2}	$CE\# = V_{CC} \pm 0.2V$ $RST\# = V_{CC} \pm 0.2V$		100	μA	2
Program/Erase current	I_{CC3}	Program/Erase controller ac- tive: $V_{pp}/WP\# = V_{IL}$ or V_{IH} ; $V_{pp}/WP\# = V_{pp}$	–	20	mA	3
Current for $V_{pp}/WP\#$ program acceleration	I_{pp}	$V_{CC} = 2.7V \pm 10\%$	–	15	mA	

- Notes: 1. The maximum input leakage current is $\pm 5\mu A$ on $V_{pp}/WP\#$.
 2. When the bus is inactive for 300ns or more, the memory enters automatic standby.
 3. Sampled only; not 100% tested.

Table 27: DC Voltage Characteristics

Parameter	Symbol	Conditions	Min	Max	Unit	Notes
Input LOW voltage	V_{IL}	–	–0.5	0.8	V	
Input HIGH voltage	V_{IH}	–	$0.7 V_{CC}$	$V_{CC} + 0.3$	V	
Voltage for $V_{pp}/WP\#$ program acceleration	V_{pp}	$V_{CC} = 2.7V \pm 10\%$	11.5	12.5	V	
Output LOW voltage	V_{OL}	$I_{OL} = 1.8mA$	–	0.45	V	
Output HIGH voltage	V_{OH}	$I_{OH} = -100\mu A$	$V_{CC} - 0.4$	–	V	
Identification voltage	V_{ID}	–	11.5	12.5	V	
Program/erase lockout supply voltage	V_{LKO}	–	1.8	2.3	V	1

- Note: 1. Sampled only; not 100% tested.

Read AC Characteristics

Table 28: Read AC Characteristics

Parameter	Symbol		Condition	Min/Max	60ns	70ns	90ns	Unit	Notes
	Legacy	JEDEC							
Address valid to next address valid	^t RC	^t AVAV	CE# = V _{IL} , OE# = V _{IL}	Min	60	70	90	ns	
Address valid to output valid	^t ACC	^t AVQV	CE# = V _{IL} , OE# = V _{IL}	Max	60	70	90	ns	
Address valid to output valid (page)	^t PAGE	^t AVQV1	CE# = V _{IL} , OE# = V _{IL}	Max	25	30	30	ns	
CE# LOW to output transition	^t LZ	^t ELQX	OE# = V _{IL}	Min	0	0	0	ns	1
CE# LOW to output valid	^t CE	^t ELQV	OE# = V _{IL}	Max	60	70	90	ns	
OE# LOW to output transition	^t OLZ	^t GLQX	CE# = V _{IL}	Min	0	0	0	ns	1
OE# LOW to output valid	^t OE	^t GLQV	CE# = V _{IL}	Max	25	30	30	ns	
CE# HIGH to output High-Z	^t HZ	^t EHQZ	OE# = V _{IL}	Max	25	30	30	ns	1
OE# HIGH to output High-Z	^t DF	^t GHQZ	CE# = V _{IL}	Max	25	30	30	ns	1
CE#, OE#, or address transition to output transition	^t OH	^t EHQX, ^t GHQX, ^t AXQX	–	Min	0	0	0	ns	
CE# to BYTE# LOW	^t ELFL	^t ELBL	–	Max	5	5	5	ns	
CE# to BYTE# HIGH	^t ELFH	^t ELBH	–	Max	5	5	5	ns	
BYTE# LOW to output High-Z	^t FLQZ	^t BLQZ	–	Max	25	25	25	ns	
BYTE# HIGH to output valid	^t FHQV	^t BHQV	–	Max	25	30	30	ns	

Note: 1. Sampled only; not 100% tested.

Figure 14: Random AC Timing

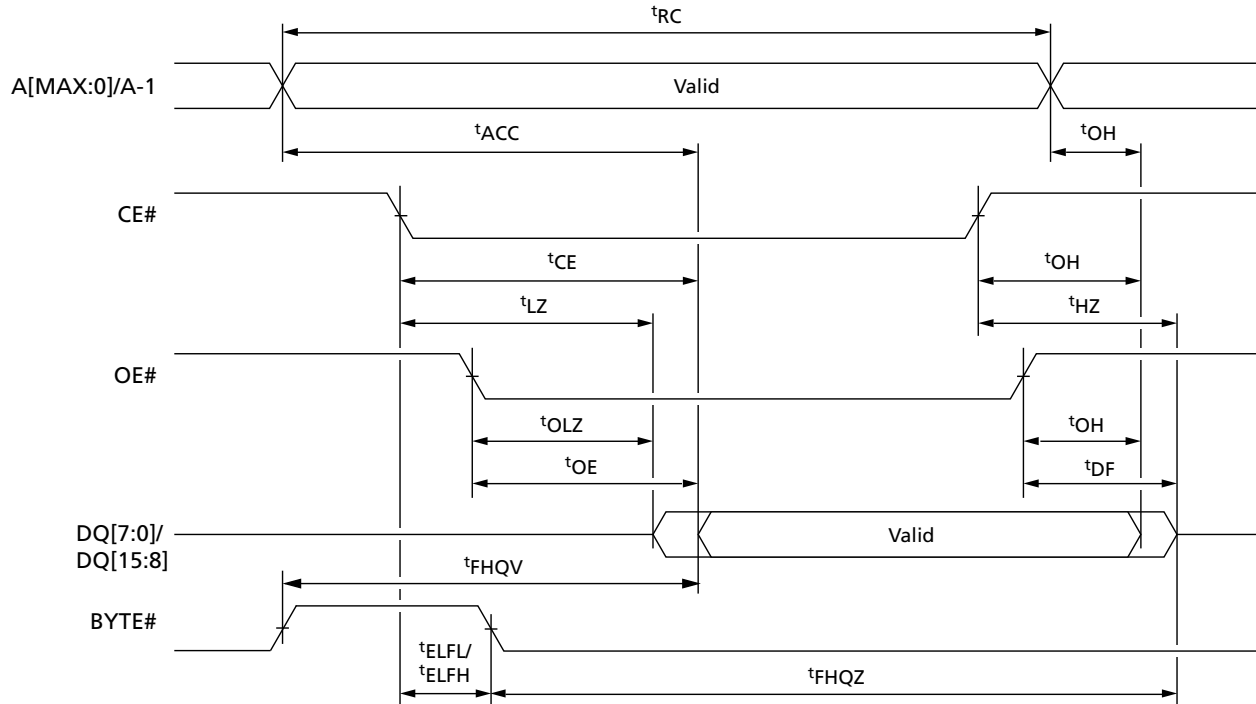

- Notes:
1. Data are output on DQ0-DQ15. DQ8-DQ14 are High-Z in 8-bit mode.
 2. Addresses differ in x8 mode.
 3. BYTE# = V_{IL} in x8 mode.

Figure 15: Page Read AC Timing

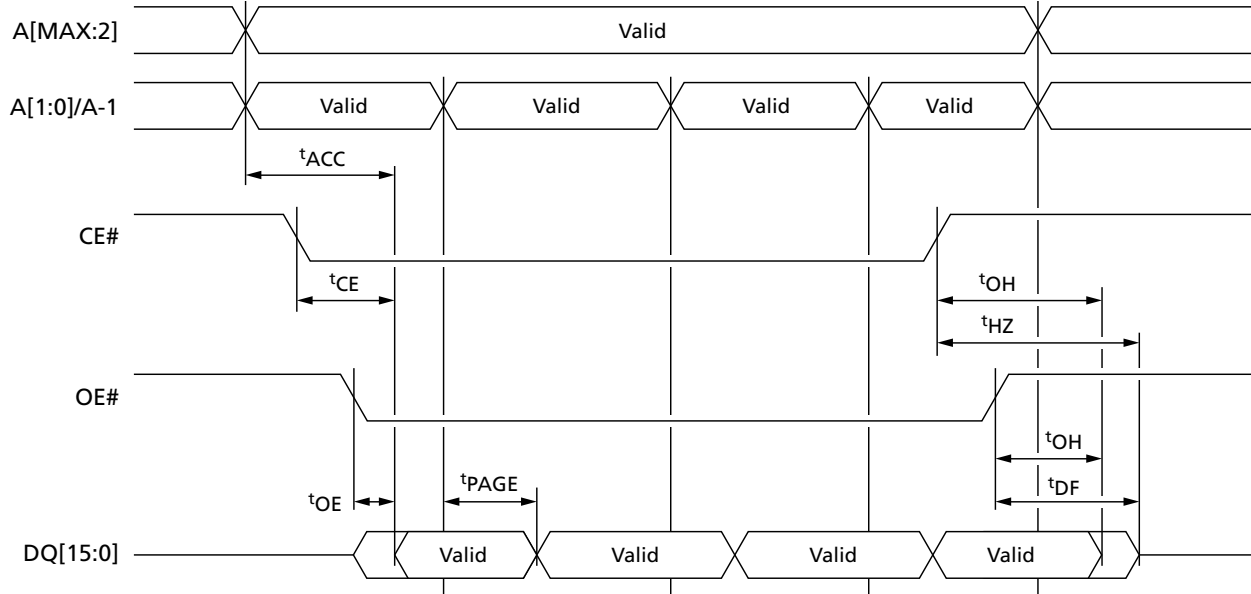

- Notes:
1. Data are output on DQ0-DQ15. DQ8-DQ14 are High-Z in 8-bit mode.
 2. Addresses differ in x8 mode.

Write AC Characteristics

Table 29: WE#-Controlled Write AC Characteristics

Parameter	Symbol		Min/Max	60ns	70ns	90ns	Unit	Notes
	Legacy	JEDEC						
Address valid to next address valid	t ^{WC}	t ^{AVAV}	Min	60	70	90	ns	
CE# LOW to WE# LOW	t ^{CS}	t ^{ELWL}	Min	0	0	0	ns	
WE# LOW to WE# HIGH	t ^{WP}	t ^{WLWH}	Min	35	35	35	ns	
Input valid to WE# HIGH	t ^{DS}	t ^{DVWH}	Min	30	30	30	ns	
WE# HIGH to input transition	t ^{DH}	t ^{WHDX}	Min	0	0	0	ns	
WE# HIGH to CE# HIGH	t ^{CH}	t ^{WHEH}	Min	0	0	0	ns	
WE# HIGH to WE# LOW	t ^{WPH}	t ^{WHWL}	Min	25	25	25	ns	
Address valid to WE# LOW	t ^{AS}	t ^{AVWL}	Min	0	0	0	ns	
WE# LOW to address transition	t ^{AH}	t ^{WLAX}	Min	45	45	45	ns	
OE# HIGH to WE# LOW	–	t ^{GHWL}	Min	0	0	0	ns	
WE# HIGH to OE# LOW	t ^{OEH}	t ^{WHGL1}	Min	0	0	0	ns	
Program/erase valid to RY/BY# LOW	t ^{BUSY}	t ^{WHRL1}	Max	0	0	0	ns	1
V _{CC} HIGH to CE# LOW	t ^{VCS}	t ^{VCHEL}	Min	50	50	50	μs	

Note: 1. Sampled only; not 100% tested.

Figure 16: WE#-Controlled AC Timing

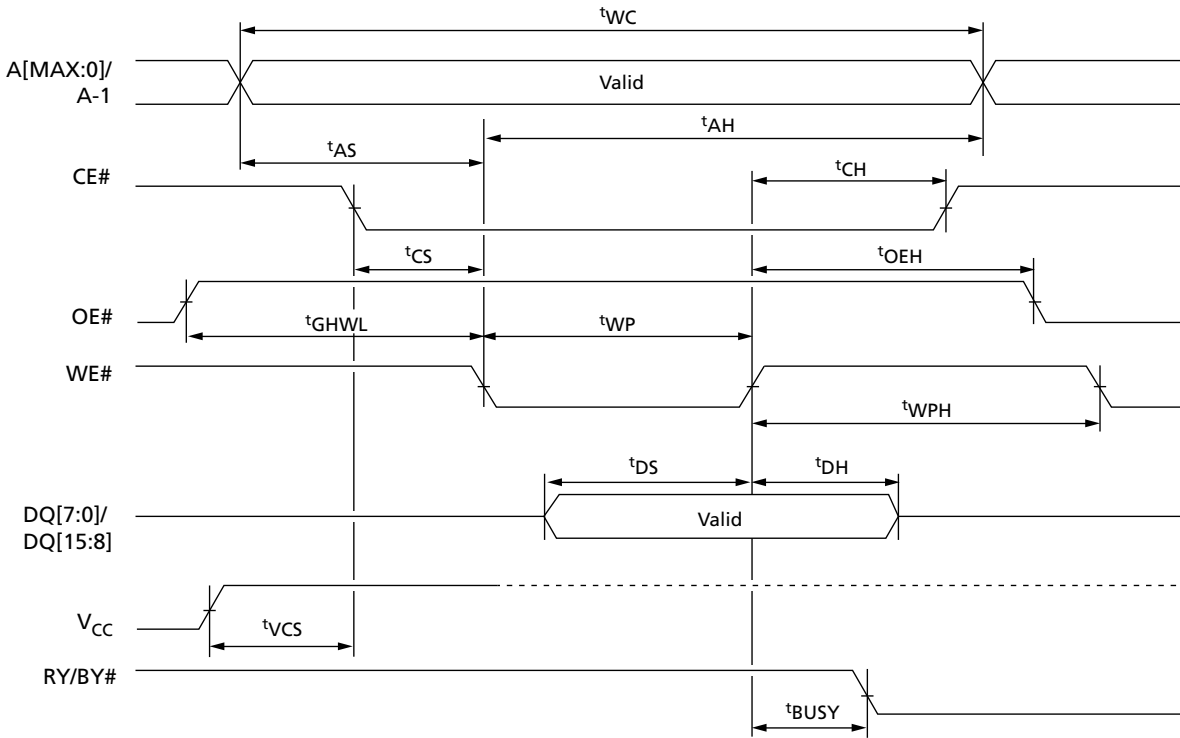

Note: 1. Addresses differ in x8 mode.

Table 30: CE#-Controlled Write AC Characteristics

Parameter	Symbol		Min/Max	60ns	70ns	90ns	Unit	Notes
	Legacy	JEDEC						
Address valid to next address valid	t ^{WC}	t ^{AVAV}	Min	60	70	90	ns	
WE# LOW to CE# LOW	t ^{WS}	t ^{WLEL}	Min	0	0	0	ns	
CE# LOW to CE# HIGH	t ^{CP}	t ^{ELEH}	Min	35	35	35	ns	
Input valid to CE# HIGH	t ^{DS}	t ^{DVEH}	Min	30	30	30	ns	
CE# HIGH to input transition	t ^{DH}	t ^{EHDH}	Min	0	0	0	ns	
CE# HIGH to WE# HIGH	t ^{WH}	t ^{EHWH}	Min	0	0	0	ns	
CE# HIGH to CE# LOW	t ^{CPH}	t ^{EHEL1}	Min	25	25	25	ns	
Address valid to CE# LOW	t ^{AS}	t ^{AVEL}	Min	0	0	0	ns	
CE# LOW to address transition	t ^{AH}	t ^{ELAX}	Min	45	45	45	ns	
OE# HIGH to CE# LOW	–	t ^{GHEL}	Min	0	0	0	ns	
CE# HIGH to OE# LOW	t ^{OEH}	t ^{EHGL1}	Min	0	0	0	ns	
Program/Erase valid to RY/BY# LOW	t ^{BUSY}	t ^{EHRL}	Max	0	0	0	ns	1
V _{CC} HIGH to WE# LOW	t ^{VCS}	t ^{VCHWL}	Min	50	50	50	ns	

Note: 1. Sampled only; not 100% tested.

Figure 17: CE#-Controlled AC Timing

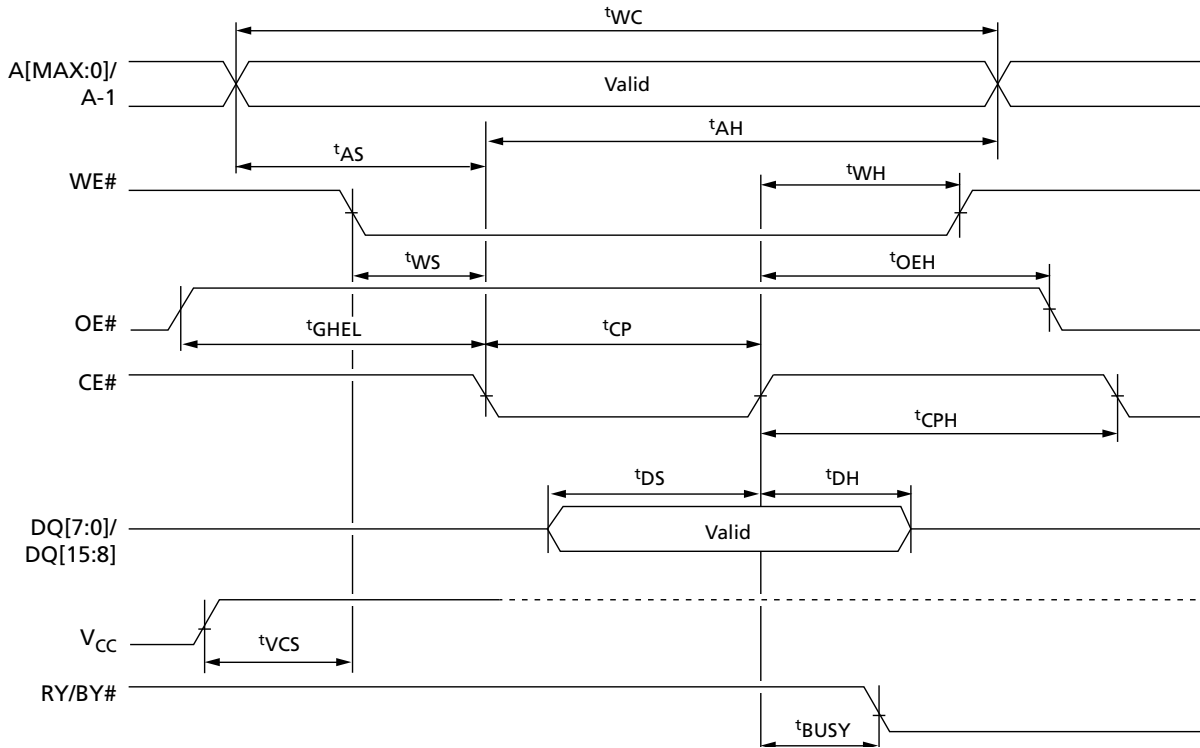

Note: 1. Addresses differ in x8 mode.

Toggle and Alternative Toggle AC Characteristics

Table 31: Toggle and Alternative Toggle AC Characteristics

Parameter	Symbol		Min/Max	60ns	70ns	90ns	Unit
	Legacy	JEDEC					
Address setup time to OE# LOW during toggle bit polling	t_{ASO}	t_{AXGL}	Min	10	10	10	ns
Address hold time from OE# during toggle bit polling	t_{AHT}	t_{GHAX}	Min	10	10	10	ns
		t_{EHAX}	Min	10	10	10	ns
CE# HIGH during toggle bit polling	t_{CEPH}	t_{EHEL2}	Min	10	10	10	ns
Output hold time during data and toggle bit polling	t_{OEHL}	t_{WHGL2}	Min	20	20	20	ns
		t_{GHGL2}	Min	20	20	20	ns

Note: 1. Data for t_{ELQV} and t_{GLQV} are in the Read AC Characteristics table.

Figure 18: Toggle/Alternative Toggle, CE# Controlled

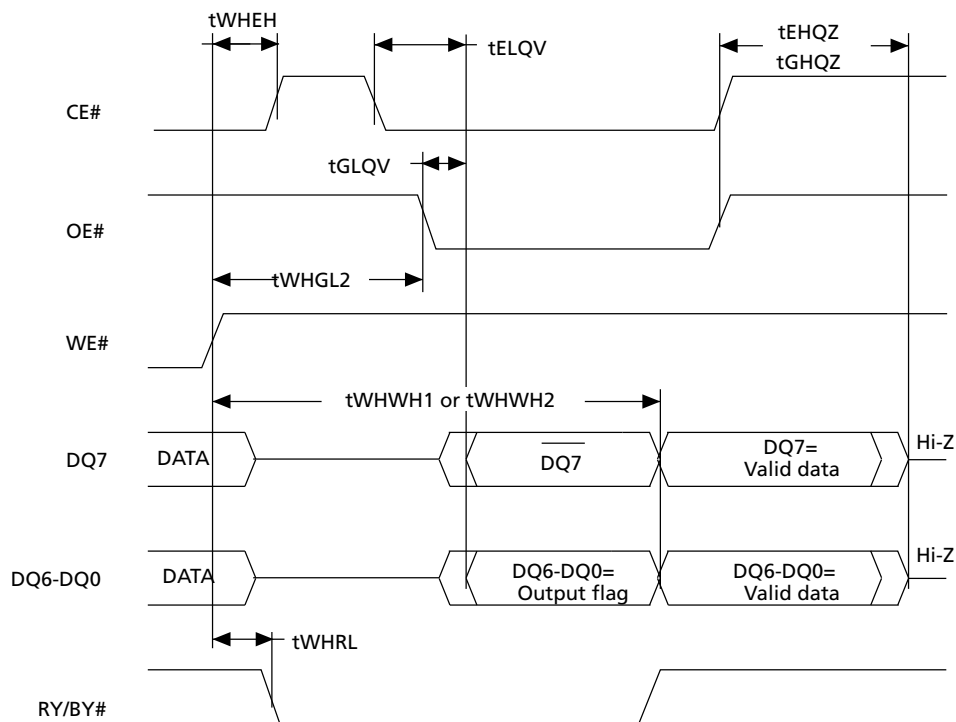

- Notes:
1. DQ7 returns valid data bit when the ongoing PROGRAM or ERASE command is completed.
 2. See the AC Characteristics for specifications.

Figure 19: Toggle/Alternative Toggle, OE# Controlled

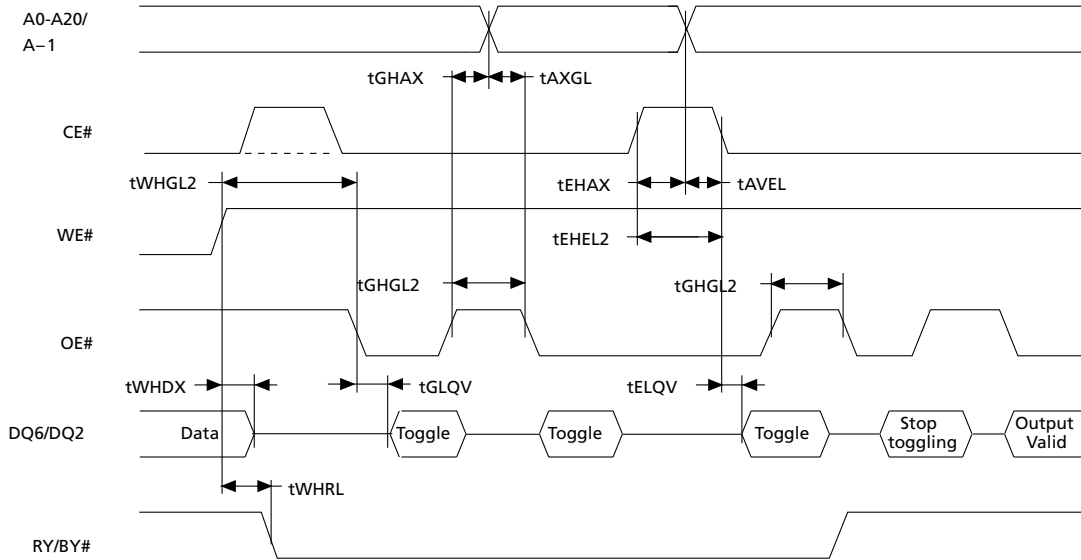

- Notes:
1. DQ6 stops toggling when the ongoing PROGRAM or ERASE command is completed. DQ2 stops toggling when the ongoing CHIP ERASE or BLOCK ERASE command is completed.
 2. Addresses differ in x8 mode.
 3. See the AC Characteristics for specifications.

Program/Erase Characteristics

Table 32: Program/Erase Times and Endurance Cycles

Notes 1 and 2 apply to the entire table

Parameter	Symbol	Min	Typ	Max	Unit	Notes
Chip erase		–	80	400	s	3
Block erase (64KB)	t_{VHWH2}	–	0.5	–	s	4, 5
Erase suspend latency time		–	–	50	μs	6
Program (byte or word)		–	10	200	μs	3
Program (double byte)			10	200	μs	3
Program (double word/quadruple byte)			10	200	μs	3
Program (quadruple word/octuple byte)			10	200	μs	3
Program (single byte and word)	t_{VHWH1}	–	10		μs	3, 7
Program (32-byte 16-word using Write to Buffer and Program)			180		μs	
Program (32-byte 16-word using Write to Buffer and Program, $V_{\text{pp}}/\text{WP}\# = 12\text{V}$)			45		μs	
Chip program (byte by byte)		–	80	400	s	3
Chip program (word by word)			40	200	s	3
Chip program (double word/quadruple byte)			20	100	s	3
Chip program (quadruple word/octuple byte)		–	10	50	s	3
Program suspend latency time		–	–	4	μs	
PROGRAM/ERASE cycles (per block)		100,000	–	–	cycles	
Data retention		20	–	–	years	

- Notes:
1. Typical values measured at room temperature and nominal voltages and for not cycled devices.
 2. Sampled, but not 100% tested.
 3. Maximum value measured at worst case conditions for both temperature and V_{CC} after 100,000 PROGRAM/ERASE cycles.
 4. Time does not include pre-programming time.
 5. Block erase polling cycle time.
 6. Maximum value measured at worst case conditions for both temperature and V_{CC} .
 7. Programming polling cycle time.

Figure 20: WE# Controlled Program Waveform

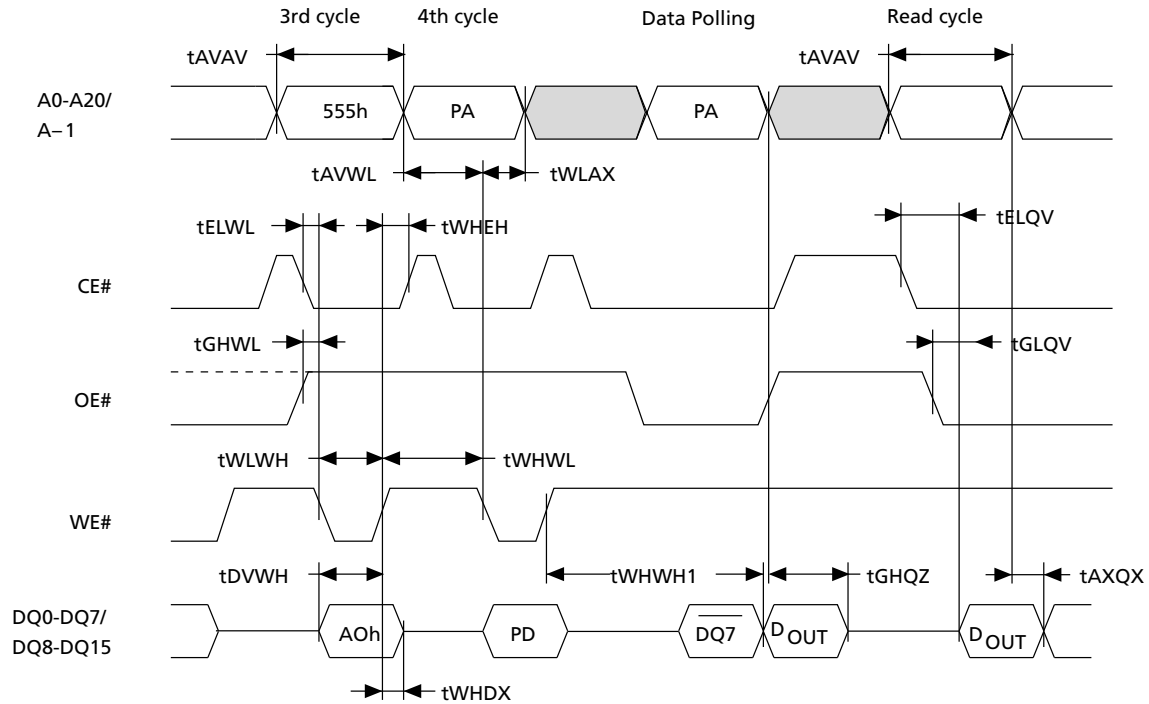

- Notes:
1. Only the third and fourth cycles of the Program command are represented. The Program command is followed by the check of status register data polling bit and by a read operation that outputs the data, DOUT, programmed by the previous Program command.
 2. PA is address of the memory location to be programmed. PD is the data to be programmed.
 3. DQ7# is the complement of the data bit being programmed to DQ7.
 4. Addresses differ in x8 mode.

Figure 21: CE# Controlled Program Waveform

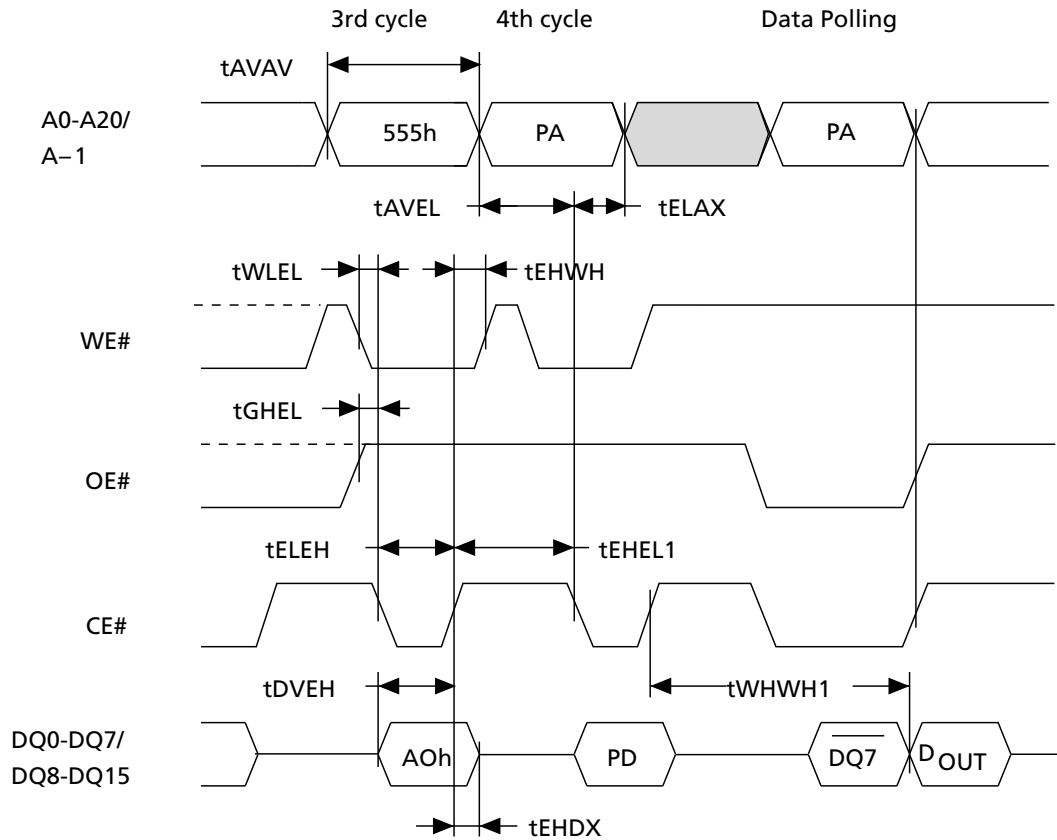

- Notes:
1. Only the third and fourth cycles of the Program command are represented. The Program command is followed by the check of status register data polling bit.
 2. PA is address of the memory location to be programmed. PD is the data to be programmed.
 3. DQ7# is the complement of the data bit being programmed to DQ7.
 4. Addresses differ in x8 mode.

Figure 22: Chip/Block Erase Waveform

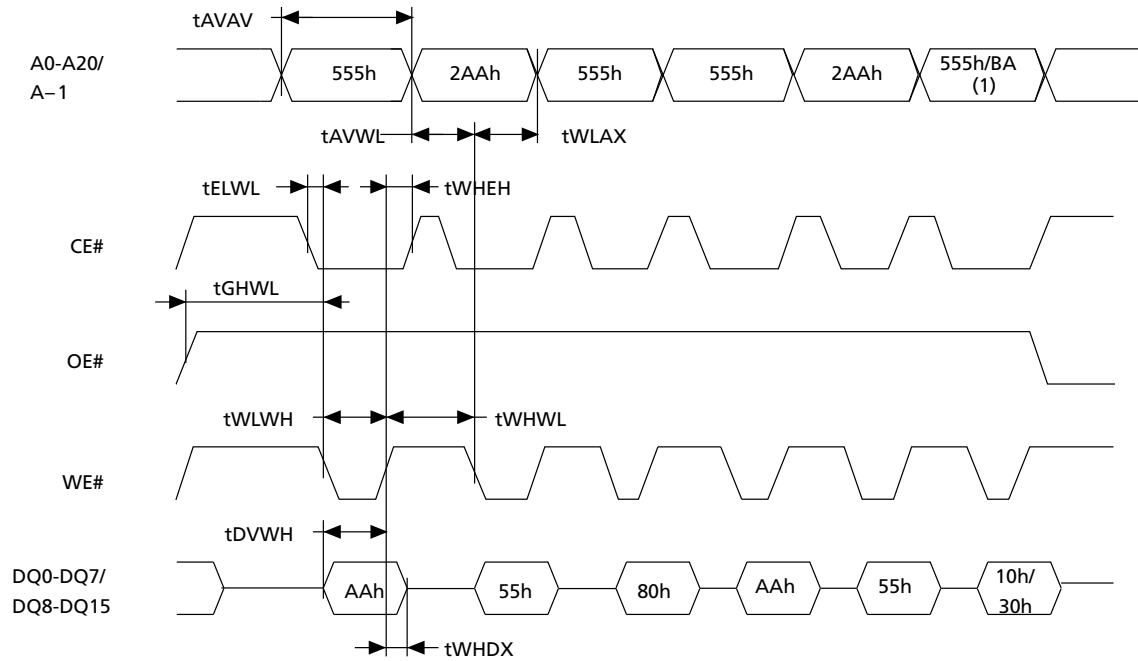

- Notes:
1. For a Chip Erase command, addresses and data are 555h and 10h, respectively, while they are BA and 30h for a Block Erase command.
 2. BA is the block address.
 3. Addresses differ in x8 mode.

Reset Characteristics

Table 33: Reset/Block Temporary Unprotect AC Characteristics

Condition/Parameter	Symbol		Min/Max	60, 70, 90ns	Unit	Notes
	Legacy	JEDEC				
RST# HIGH to WE# LOW, CE# LOW, OE# LOW	t_{RH}	t_{PHWL} t_{PHEL} t_{PHGL}	Min	50	ns	1
RY/BY# HIGH to WE# LOW, CE# LOW, OE# LOW	t_{RB}	t_{RHWL} t_{RHEL} t_{RHGL}	Min	0	ns	1
RST# pulse width	t_{RP}	t_{PLPX}	Min	500	ns	
RST# LOW to read mode	t_{READY}	t_{PLYH}	Max	50	μs	1
RST# rise time to V_{ID}	t_{VIDR}	t_{PHPHH}	Min	500	ns	1, 2
V_{pp} rise and fall time	–	t_{VHVPP}	Min	500	ns	1

- Notes: 1. Sampled only; not 100% tested.
2. For fast program operations using $V_{pp}/WP\#$ at 12V.

Figure 23: Reset/Block Temporary Unprotect AC Waveforms

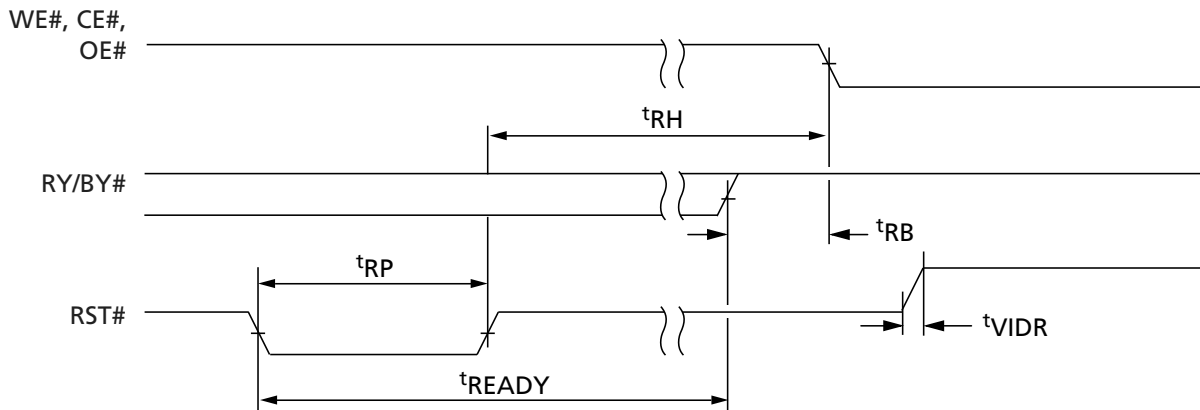
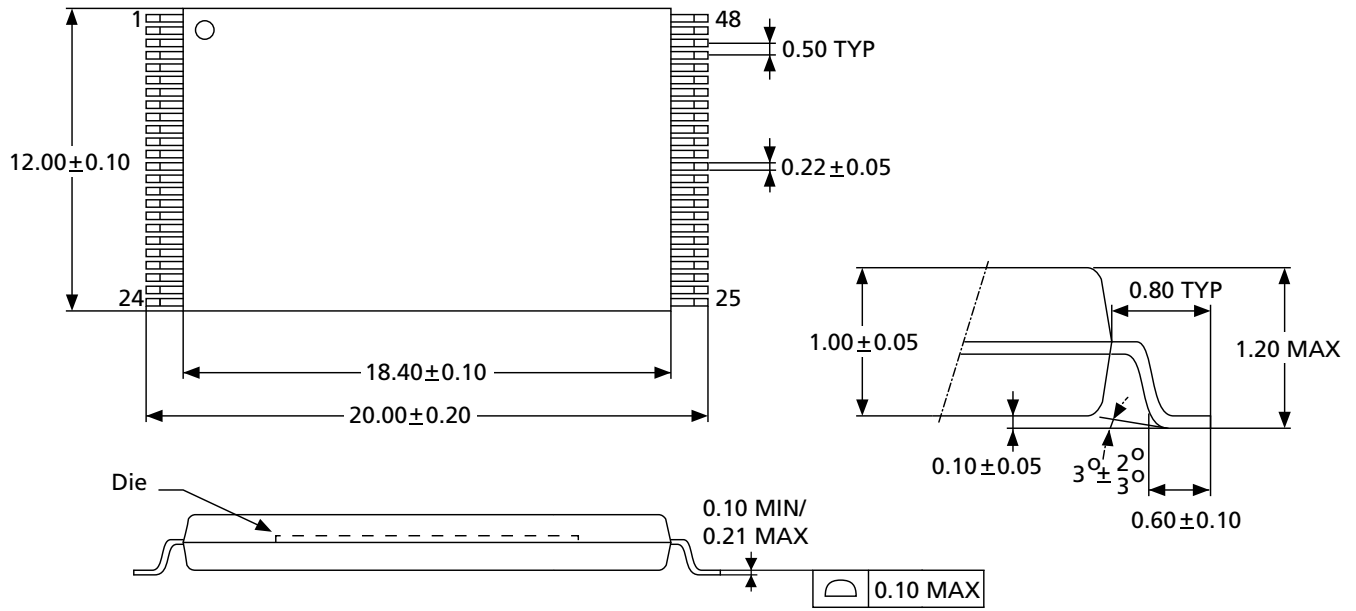

Figure 24: Accelerated Programming Timing Waveform



Package Dimensions

Figure 25: 48-Pin TSOP – 12mm x 20mm



Note: 1. All dimensions are in millimeters.

Figure 27: 48-Ball TFBGA – 6mm x 8mm

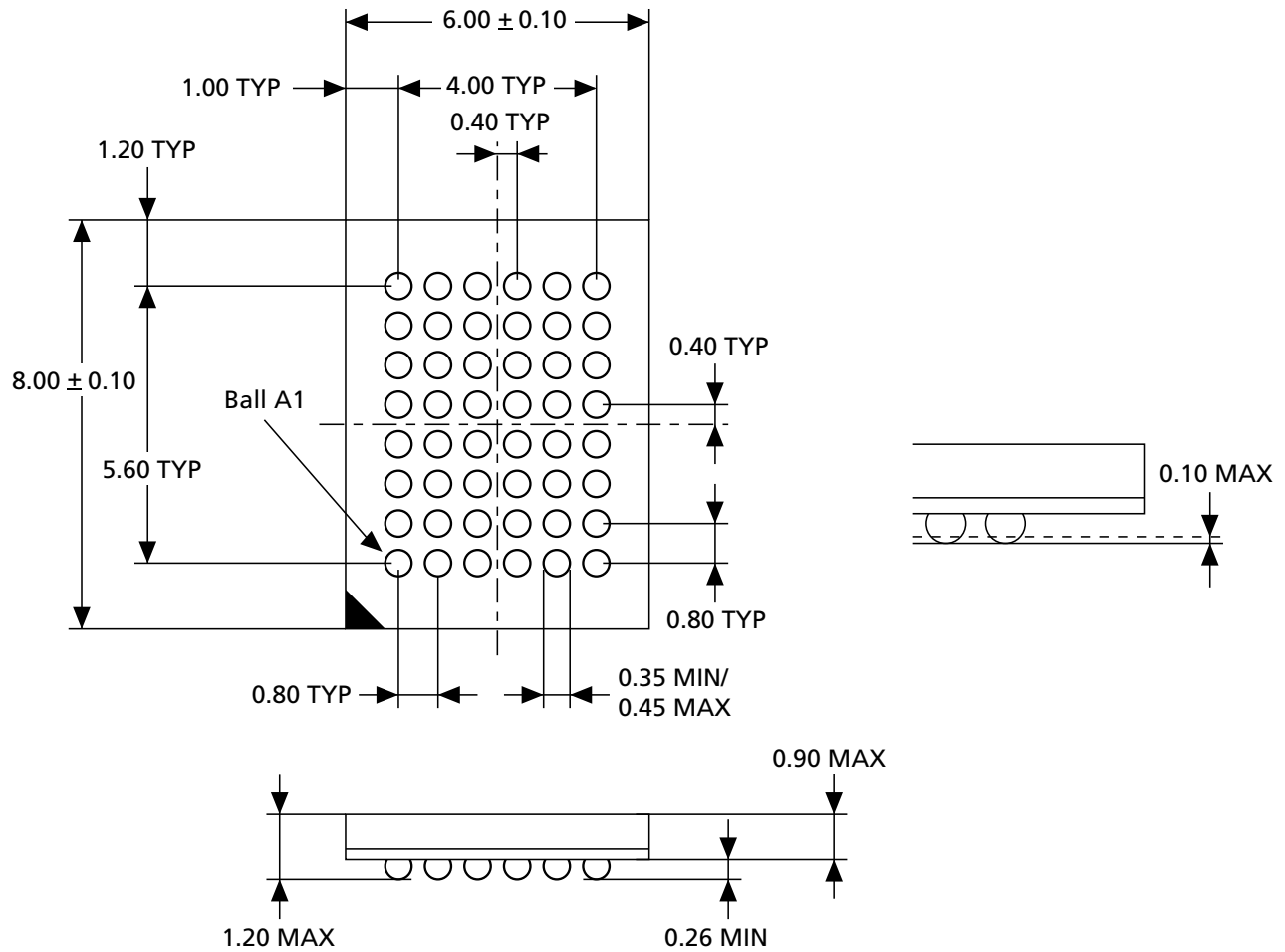

Note: 1. All dimensions are in millimeters.

Figure 28: 64-Ball TBGA – 10mm x 13mm

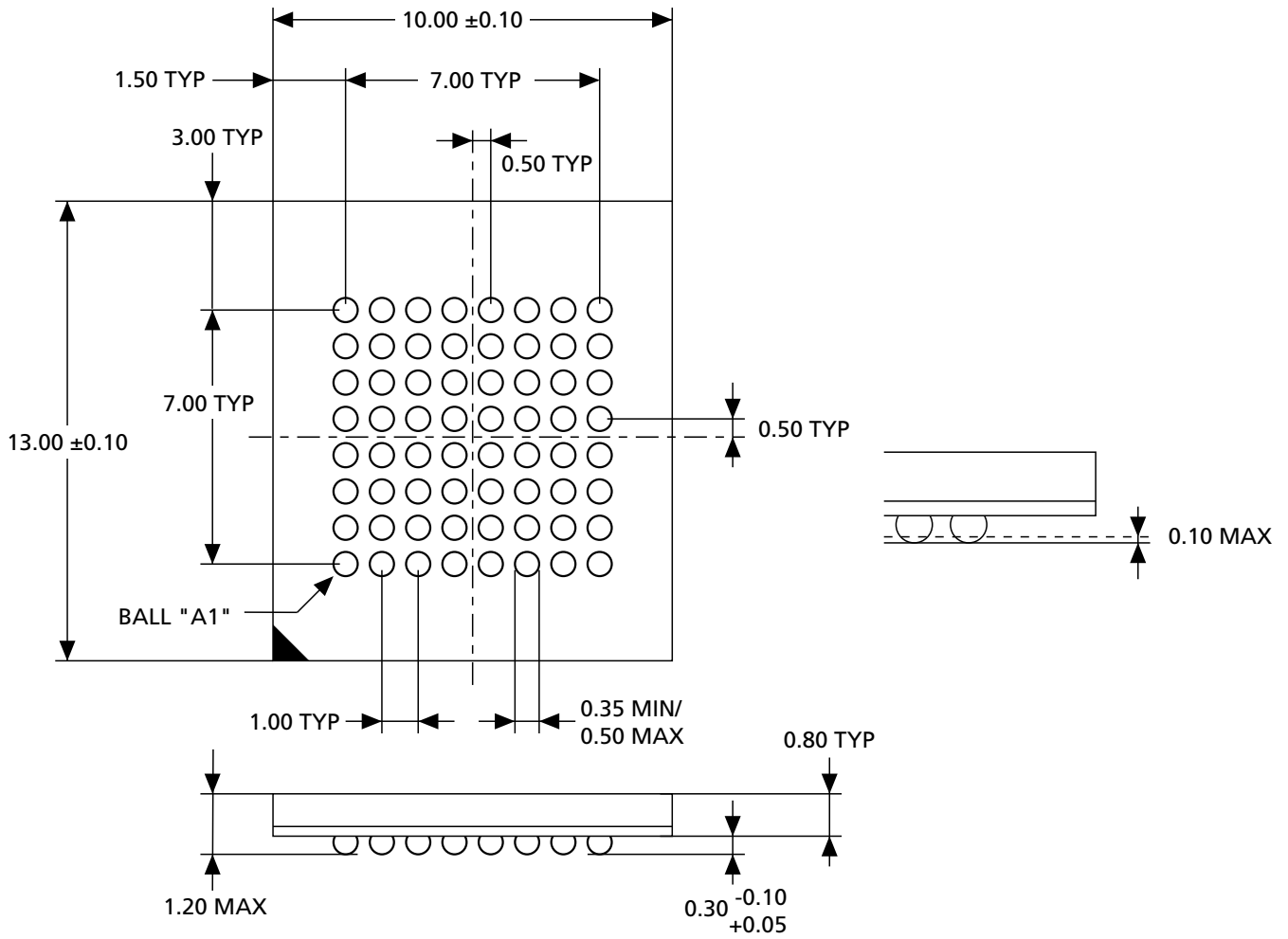

Note: 1. All dimensions are in millimeters.

Figure 29: 64-Ball FBGA – 11mm x 13mm

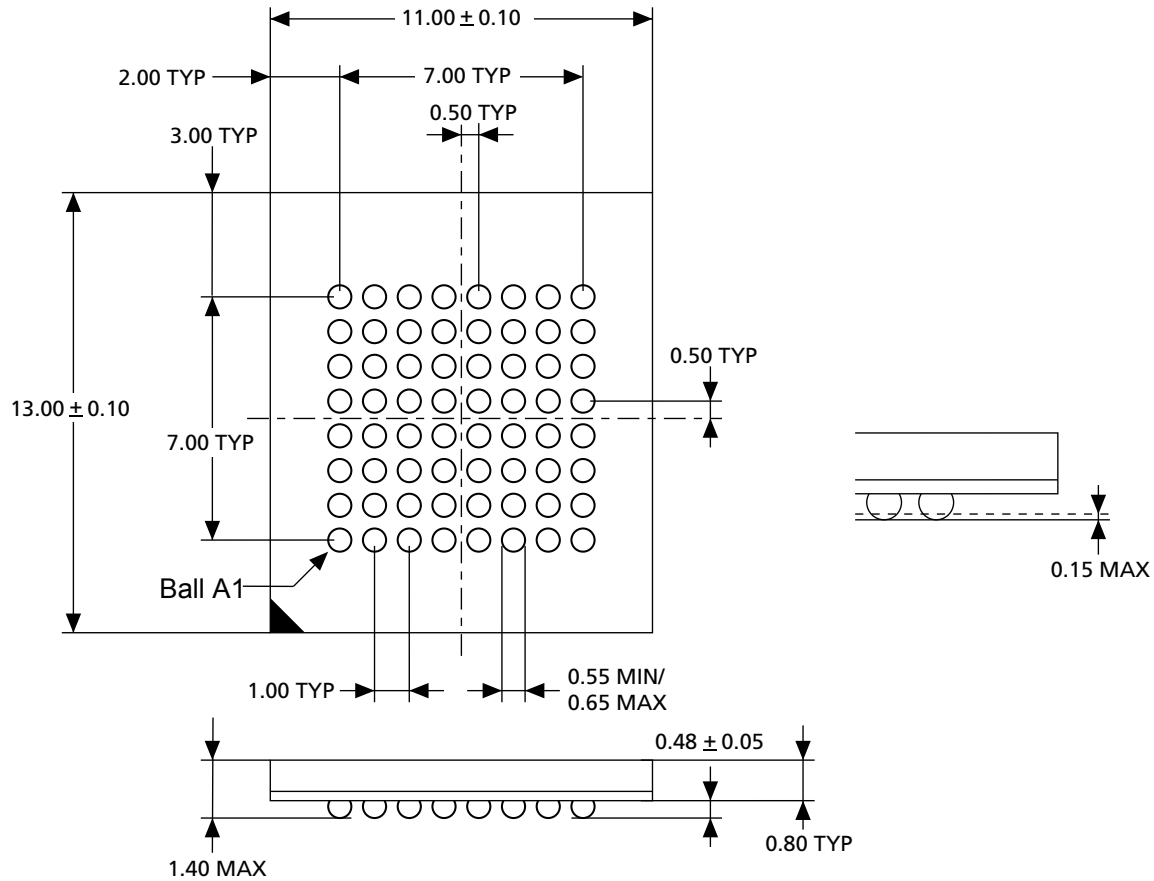

Note: 1. All dimensions are in millimeters.

Revision History

Rev. D – 03/15

- Updated MPN decoder
- Updated 56-pin TSOP 14mm x 20mm package

Rev. C – 07/13

- Updated Command Interface and Command tables

Rev. B – 06/13

- Removed Part Numbers by Array Matrix table in Features

Rev. A – 11/12

- Initial Micron brand release

8000 S. Federal Way, P.O. Box 6, Boise, ID 83707-0006, Tel: 208-368-4000
www.micron.com/products/support Sales inquiries: 800-932-4992
Micron and the Micron logo are trademarks of Micron Technology, Inc.
All other trademarks are the property of their respective owners.

This data sheet contains minimum and maximum limits specified over the power supply and temperature range set forth herein. Although considered final, these specifications are subject to change, as further product development and data characterization sometimes occur.

Looking for pricing, stock, or lifecycle information?

Click below to explore more details on WIN SOURCE:

- ⊖ [View M29W640GB70ZF3F TR on WIN SOURCE](#)
- ⊖ [Micron Technology Inc. Information](#)

Optimize Your Supply Chain with WIN SOURCE Solutions

- ✓ Global Sourcing Solution
- ✓ Obsolete Management
- ✓ Cost Control Management
- ✓ Shortage Management
- ✓ Alternative Solution
- ✓ Excess Inventory Management