



**THE DATASHEET OF
M25P64-VMF3PB**



Features

- 64 Mbit of Flash memory
- 2.7 V to 3.6 V single supply voltage
- SPI bus compatible serial interface
- 75 MHz clock rate (maximum)
- Page Program (up to 256 Bytes)
 - in 1.4 ms (typical)
 - in 0.35 ms (typical with $V_{PP} = 9\text{ V}$)
- Sector Erase (512 Kbit)
- Bulk Erase (64 Mbit)
- Electronic Signatures
 - JEDEC standard two-Byte signature (2017h)
 - RES instruction, one-Byte, signature (16h), for backward compatibility
 - Unique ID code (UID) with 16 bytes readonly: available upon customer request
- Hardware Write Protection: protected area size defined by three non-volatile bits (BP0, BP1 and BP2)
- More than 100 000 Erase/Program cycles per sector
- More than 20-year data retention
- Packages
 - RoHS compliant
- Automotive certified parts available

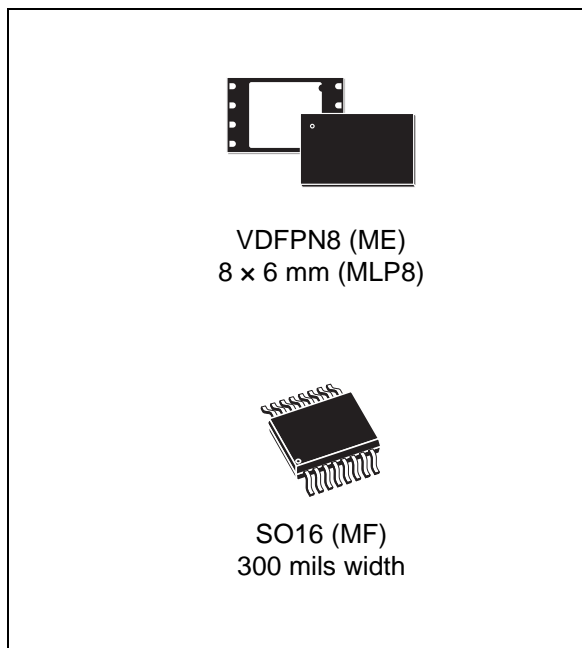

Contents

1	Description	6
2	Signal description	9
2.1	Serial Data Output (Q)	9
2.2	Serial Data Input (D)	9
2.3	Serial Clock (C)	9
2.4	Chip Select (S)	9
2.5	Hold (HOLD)	9
2.6	Write Protect/Enhanced Program supply voltage (W/V _{PP})	10
2.7	V _{CC} supply voltage	10
2.8	V _{SS} ground	10
3	SPI modes	11
4	Operating features	13
4.1	Page Programming	13
4.2	Sector Erase and Bulk Erase	13
4.3	Polling during a Write, Program or Erase cycle	13
4.4	Fast Program/Erase mode	13
4.5	Active Power and Standby Power modes	14
4.6	Status Register	14
4.7	Protection modes	15
4.8	Hold Condition	16
5	Memory organization	17
6	Instructions	22
6.1	Write Enable (WREN)	23
6.2	Write Disable (WRDI)	24
6.3	Read Identification (RDID)	25
6.4	Read Status Register (RDSR)	26
6.4.1	WIP bit	26

6.4.2	WEL bit	26
6.4.3	BP2, BP1, BP0 bits	26
6.4.4	SRWD bit	27
6.5	Write Status Register (WRSR)	28
6.6	Read Data Bytes (READ)	30
6.7	Read Data Bytes at Higher Speed (FAST_READ)	31
6.8	Page Program (PP)	32
6.9	Sector Erase (SE)	34
6.10	Bulk Erase (BE)	35
6.11	Read Electronic Signature (RES)	36
7	Power-up and Power-down	37
8	Initial delivery state	39
9	Maximum rating	39
10	DC and AC parameters	40
11	Package mechanical	48
12	Ordering Information, Standard Parts	50
13	Ordering Information, Automotive Parts	52
14	Revision history	53

List of tables

Table 1.	Signal names	7
Table 2.	Protected area sizes	15
Table 3.	Memory organization	18
Table 4.	Instruction set	22
Table 5.	Read identification (RDID) data-out sequence	25
Table 6.	Status Register format	26
Table 7.	Protection modes	28
Table 8.	Power-Up timing and VWI threshold	38
Table 9.	Absolute maximum ratings	39
Table 10.	Operating conditions	40
Table 11.	Data Retention and Endurance	40
Table 12.	AC measurement conditions	40
Table 13.	Capacitance	41
Table 14.	DC characteristics	41
Table 15.	DC characteristics process technology T9HX	42
Table 16.	AC characteristics	43
Table 17.	AC characteristics, T9HX parts	44
Table 18.	VDFPN8 (MLP8) 8-lead Very thin Dual Flat Package No lead, 8 × 6 mm, package mechanical data	48
Table 19.	SO16 wide – 16 lead Plastic Small Outline, 300 mils body width, package mechanical data	49
Table 20.	Ordering information scheme	50
Table 21.	Ordering information scheme	52
Table 22.	Document revision history	53

List of figures

Figure 1.	Logic diagram	7
Figure 2.	VDFPN connections	7
Figure 3.	SO connections	8
Figure 4.	Bus master and memory devices on the SPI bus	11
Figure 5.	SPI modes supported	12
Figure 6.	Hold condition activation	16
Figure 7.	Block diagram	17
Figure 8.	Write Enable (WREN) instruction sequence	23
Figure 9.	Write Disable (WRDI) instruction sequence	24
Figure 10.	Read Identification (RDID) instruction sequence and data-out sequence	26
Figure 11.	Read Status Register (RDSR) instruction sequence and data-out sequence	27
Figure 12.	Write Status Register (WRSR) instruction sequence	29
Figure 13.	Read Data Bytes (READ) instruction sequence and data-out sequence	30
Figure 14.	Read Data Bytes at Higher Speed (FAST_READ) instruction and data-out sequence	31
Figure 15.	Page Program (PP) instruction sequence	33
Figure 16.	Sector Erase (SE) instruction sequence	34
Figure 17.	Bulk Erase (BE) instruction sequence	35
Figure 18.	Read Electronic Signature (RES) instruction sequence and data-out sequence	36
Figure 19.	Power-up timing	38
Figure 20.	AC measurement I/O waveform	41
Figure 21.	Serial input timing	45
Figure 22.	Write Protect setup and hold timing during WRSR when SRWD = 1	46
Figure 23.	Hold timing	46
Figure 24.	Output timing	47
Figure 25.	V _{PPH} timing	47
Figure 26.	VDFPN8 (MLP8) 8-lead Very thin Dual Flat Package No lead, 8 × 6 mm, package outline	48
Figure 27.	SO16 wide – 16 lead Plastic Small Outline, 300 mils body width	49

1 Description

The M25P64 is a 64 Mbit (8M x 8) Serial Flash Memory, with advanced write protection mechanisms, accessed by a high speed SPI-compatible bus instructions allowing clock frequency up to 75 MHz.⁽¹⁾

The memory can be programmed 1 to 256 bytes at a time, using the Page Program instruction.

An enhanced Fast Program/Erase mode is available to speed up operations in factory environment. The device enters this mode whenever the V_{PPH} voltage is applied to the Write Protect/Enhanced Program Supply Voltage pin (\overline{W}/V_{PP}).⁽²⁾

The memory is organized as 128 sectors, each containing 256 pages. Each page is 256 bytes wide. Thus, the whole memory can be viewed as consisting of 32768 pages, or 8388608 bytes.

The whole memory can be erased using the Bulk Erase instruction, or a sector at a time, using the Sector Erase instruction.

In order to meet environmental requirements, Numonyx offers the M25P64 in Lead-free and RoHS compliant packages.

Note: Important: This datasheet details the functionality of the M25P64 devices, based on the previous process or based on the current T9HX process (available since March 2008). The new device in T9HX is backward compatible with the old one and it includes these additional features:

- improved max frequency (Fast Read) to 75 MHz
- UID/CFD protection feature

-
1. 75 MHz operation is available only for process technology T9HX devices, identified by process identification digit "4" in the device marking.
 2. Avoid applying VPPH to the W/VPP pin during Bulk Erase with process technology T9HX devices, identified by process identification digit "4" in the device marking.

Figure 1. Logic diagram

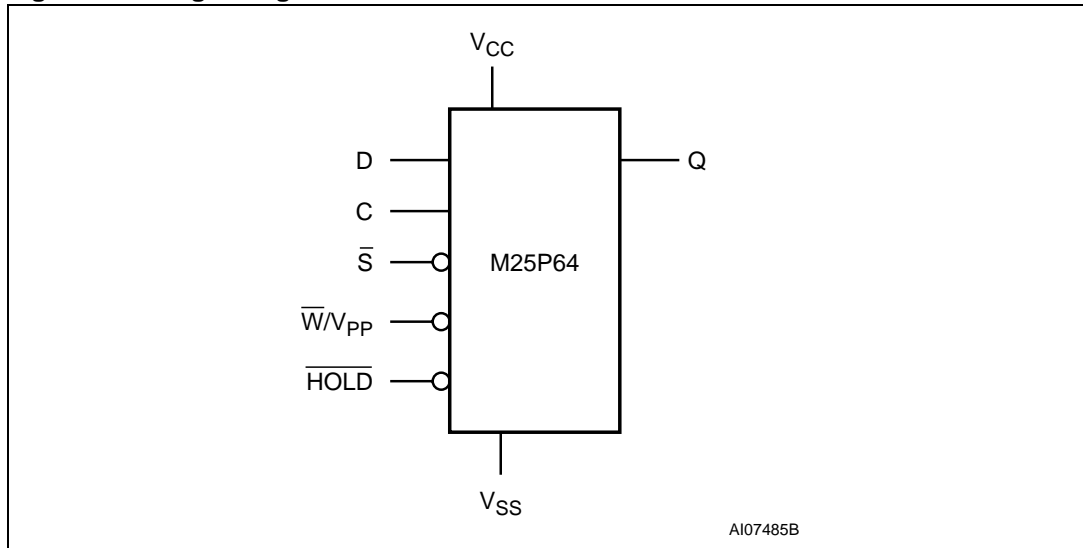
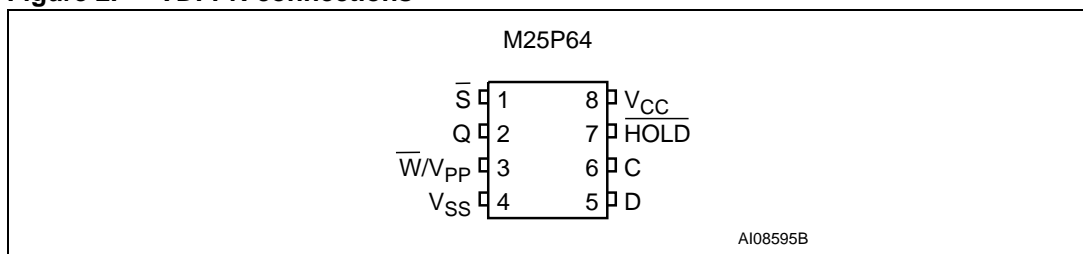

Table 1. Signal names

Signal name	Function	Direction
C	Serial Clock	Input
D	Serial Data Input	Input
Q	Serial Data Output	Output
S	Chip Select	Input
$\overline{W/V_{PP}}$	Write Protect/Enhanced Program Supply Voltage	Input
\overline{HOLD}	Hold	Input
V_{CC}	Supply Voltage	
V_{SS}	Ground	

Figure 2. VDFPN connections



1. There is an exposed central pad on the underside of the VDFPN package. This is pulled, internally, to V_{SS} , and must not be allowed to be connected to any other voltage or signal line on the PCB.
2. See [Section 11: Package mechanical](#) for package dimensions, and how to identify pin-1.

Figure 3. SO connections

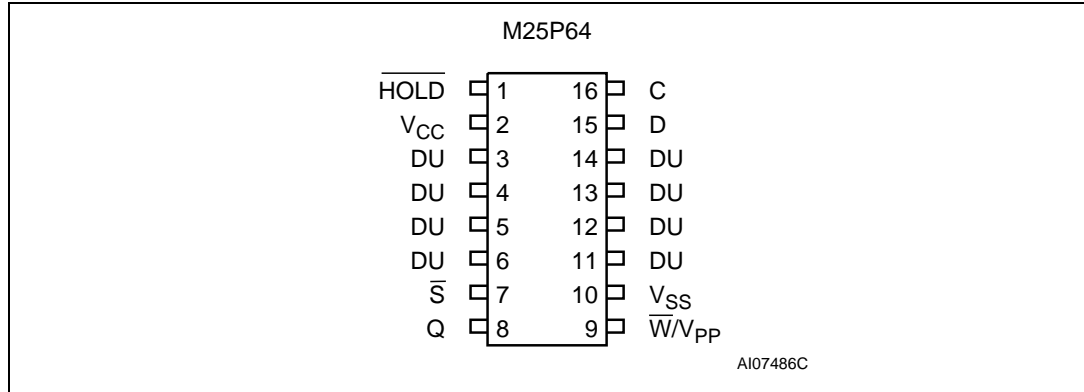

1. DU = Don't Use
2. See [Section 11: Package mechanical](#) for package dimensions, and how to identify pin-1.

2 Signal description

2.1 Serial Data Output (Q)

This output signal is used to transfer data serially out of the device. Data is shifted out on the falling edge of Serial Clock (C).

2.2 Serial Data Input (D)

This input signal is used to transfer data serially into the device. It receives instructions, addresses, and the data to be programmed. Values are latched on the rising edge of Serial Clock (C).

2.3 Serial Clock (C)

This input signal provides the timing of the serial interface. Instructions, addresses, or data present at Serial Data Input (D) are latched on the rising edge of Serial Clock (C). Data on Serial Data Output (Q) changes after the falling edge of Serial Clock (C).

2.4 Chip Select (\bar{S})

When this input signal is High, the device is deselected and Serial Data Output (Q) is at high impedance. Unless an internal Program, Erase or Write Status Register cycle is in progress, the device will be in the Standby Power mode. Driving Chip Select (\bar{S}) Low selects the device, placing it in the Active Power mode.

After Power-up, a falling edge on Chip Select (\bar{S}) is required prior to the start of any instruction.

2.5 Hold ($\overline{\text{HOLD}}$)

The Hold ($\overline{\text{HOLD}}$) signal is used to pause any serial communications with the device without deselecting the device.

During the Hold condition, the Serial Data Output (Q) is high impedance, and Serial Data Input (D) and Serial Clock (C) are Don't Care.

To start the Hold condition, the device must be selected, with Chip Select (\bar{S}) driven Low.

2.6 Write Protect/Enhanced Program supply voltage (\overline{W}/V_{PP})

\overline{W}/V_{PP} is both a control input and a power supply pin. The two functions are selected by the voltage range applied to the pin.

If the \overline{W}/V_{PP} input is kept in a low voltage range (0V to V_{CC}) the pin is seen as a control input. This input signal is used to freeze the size of the area of memory that is protected against program or erase instructions (as specified by the values in the BP2, BP1 and BP0 bits of the Status Register).

If V_{PP} is in the range of V_{PPH} it acts as an additional power supply pin. In this case V_{PP} must be stable until the Program/Erase algorithm is completed.⁽¹⁾

2.7 V_{CC} supply voltage

V_{CC} is the supply voltage.

2.8 V_{SS} ground

V_{SS} is the reference for the V_{CC} supply voltage.

1. Avoid applying V_{PPH} to the W/V_{PP} pin during Bulk Erase with process technology T9HX devices, identified by process identification digit "4" in the device marking.

3 SPI modes

These devices can be driven by a microcontroller with its SPI peripheral running in either of the two following modes:

- CPOL=0, CPHA=0
- CPOL=1, CPHA=1

For these two modes, input data is latched in on the rising edge of Serial Clock (C), and output data is available from the falling edge of Serial Clock (C).

The difference between the two modes, as shown in [Figure 5](#), is the clock polarity when the bus master is in Stand-by mode and not transferring data:

- C remains at 0 for (CPOL=0, CPHA=0)
- C remains at 1 for (CPOL=1, CPHA=1)

Figure 4. Bus master and memory devices on the SPI bus

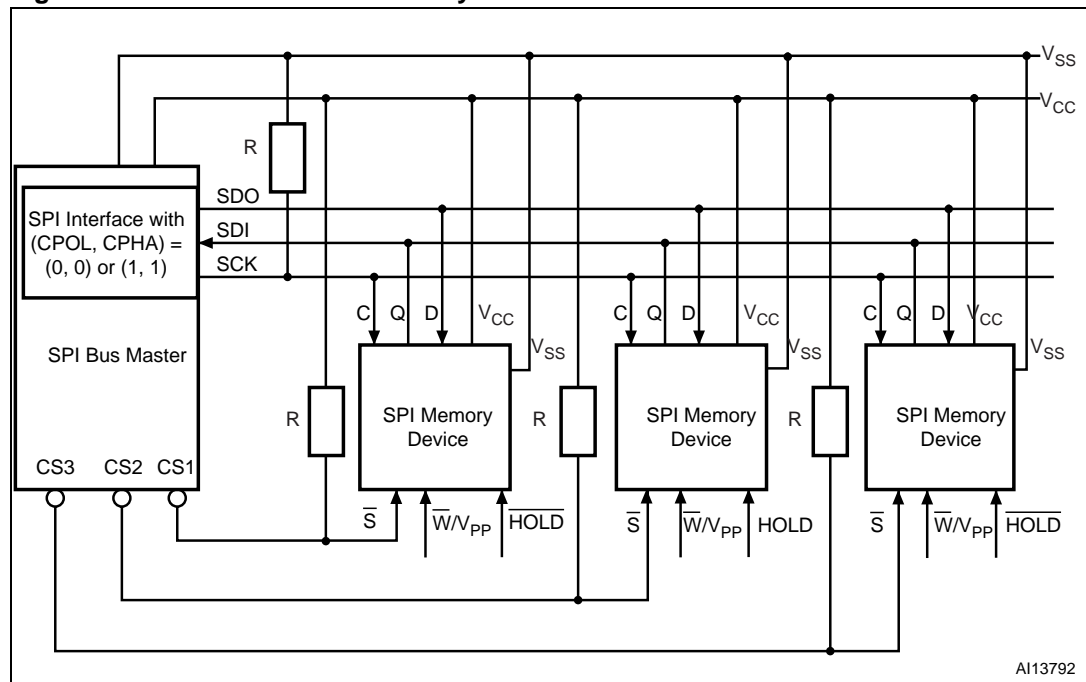

1. The Write Protect ($\overline{W/V_{PP}}$) and Hold (\overline{HOLD}) signals should be driven, High or Low as appropriate.

[Figure 4](#) shows an example of three devices connected to an MCU, on an SPI bus. Only one device is selected at a time, so only one device drives the Serial Data Output (Q) line at a time, the other devices are high impedance. Resistors R (represented in [Figure 4](#)) ensure that the M25P64 is not selected if the Bus Master leaves the \overline{S} line in the high impedance state. As the Bus Master may enter a state where all inputs/outputs are in high impedance at the same time (for example, when the Bus Master is reset), the clock line (C) must be connected to an external pull-down resistor so that, when all inputs/outputs become high impedance, the \overline{S} line is pulled High while the C line is pulled Low (thus ensuring that \overline{S} and C do not become High at the same time, and so, that the t_{SHCH} requirement is met). The typical value of R is 100 k Ω , assuming that the time constant $R \cdot C_p$ (C_p = parasitic capacitance of the bus line) is shorter than the time during which the Bus Master leaves the SPI bus in high impedance.

Example: $C_p = 50 \text{ pF}$, that is $R \cdot C_p = 5 \text{ }\mu\text{s} \iff$ the application must ensure that the Bus Master never leaves the SPI bus in the high impedance state for a time period shorter than $5 \text{ }\mu\text{s}$.

Figure 5. SPI modes supported

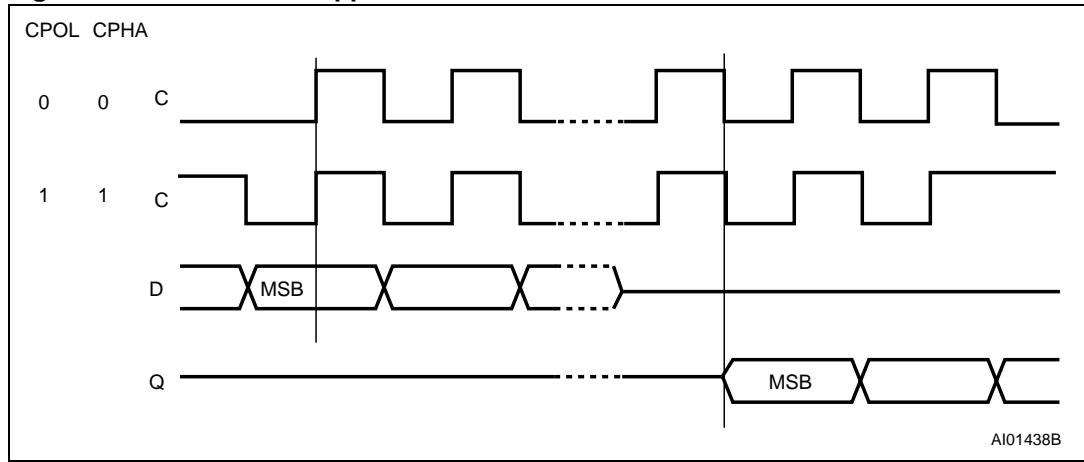

4 Operating features

4.1 Page Programming

To program one data byte, two instructions are required: Write Enable (WREN), which is one byte, and a Page Program (PP) sequence, which consists of four bytes plus data. This is followed by the internal Program cycle (of duration t_{PP}).

To spread this overhead, the Page Program (PP) instruction allows up to 256 bytes to be programmed at a time (changing bits from 1 to 0), provided that they lie in consecutive addresses on the same page of memory.

For optimized timings, it is recommended to use the Page Program (PP) instruction to program all consecutive targeted Bytes in a single sequence versus using several Page Program (PP) sequences with each containing only a few Bytes (see [Page Program \(PP\)](#) and [Table 16: AC characteristics](#)).

4.2 Sector Erase and Bulk Erase

The Page Program (PP) instruction allows bits to be reset from 1 to 0. Before this can be applied, the bytes of memory need to have been erased to all 1s (FFh). This can be achieved either a sector at a time, using the Sector Erase (SE) instruction, or throughout the entire memory, using the Bulk Erase (BE) instruction. This starts an internal Erase cycle (of duration t_{SE} or t_{BE}).

The Erase instruction must be preceded by a Write Enable (WREN) instruction.

4.3 Polling during a Write, Program or Erase cycle

A further improvement in the time to Write Status Register (WRSR), Program (PP) or Erase (SE or BE) can be achieved by not waiting for the worst case delay (t_W , t_{PP} , t_{SE} , or t_{BE}). The Write In Progress (WIP) bit is provided in the Status Register so that the application program can monitor its value, polling it to establish when the previous Write cycle, Program cycle or Erase cycle is complete.

4.4 Fast Program/Erase mode

The Fast Program/Erase mode is used to speed up programming/erasing. The device enters the Fast Program/Erase mode during the Page Program, Sector Erase, or Bulk Erase⁽¹⁾ instruction whenever a voltage equal to V_{PPH} is applied to the \overline{W}/V_{PP} pin.

The use of the Fast Program/Erase mode requires specific operating conditions in addition to the normal ones (V_{CC} must be within the normal operating range):

- the voltage applied to the \overline{W}/V_{PP} pin must be equal to V_{PPH} (see [Table 10](#))
- ambient temperature, T_A must be $25^\circ\text{C} \pm 10^\circ\text{C}$,
- the cumulated time during which \overline{W}/V_{PP} is at V_{PPH} should be less than 80 hours

1. Avoid applying V_{PPH} to the \overline{W}/V_{PP} pin during Bulk Erase with process technology T9HX devices, identified by process identification digit "4" in the device marking.

4.5 Active Power and Standby Power modes

When Chip Select (\overline{S}) is Low, the device is selected, and in the Active Power mode.

When Chip Select (\overline{S}) is High, the device is deselected, but could remain in the Active Power mode until all internal cycles have completed (Program, Erase, Write Status Register). The device then goes in to the Standby Power mode. The device consumption drops to I_{CC1} .

4.6 Status Register

The Status Register contains a number of status and control bits that can be read or set (as appropriate) by specific instructions. For a detailed description of the Status Register bits, see [Section 6.4: Read Status Register \(RDSR\)](#).

4.7 Protection modes

The environments where non-volatile memory devices are used can be very noisy. No SPI device can operate correctly in the presence of excessive noise. To help combat this, the M25P64 features the following data protection mechanisms:

- Power On Reset and an internal timer (t_{PUW}) can provide protection against inadvertent changes while the power supply is outside the operating specification.
- Program, Erase and Write Status Register instructions are checked that they consist of a number of clock pulses that is a multiple of eight, before they are accepted for execution.
- All instructions that modify data must be preceded by a Write Enable (WREN) instruction to set the Write Enable Latch (WEL) bit. This bit is returned to its reset state by the following events:
 - Power-up
 - Write Disable (WRDI) instruction completion
 - Write Status Register (WRSR) instruction completion
 - Page Program (PP) instruction completion
 - Sector Erase (SE) instruction completion
 - Bulk Erase (BE) instruction completion
- The Block Protect (BP2, BP1, BP0) bits allow part of the memory to be configured as read-only. This is the Software Protected Mode (SPM).
- The Write Protect (\overline{W}/V_{PP}) signal allows the Block Protect (BP2, BP1, BP0) bits and Status Register Write Disable (SRWD) bit to be protected. This is the Hardware Protected Mode (HPM).

Table 2. Protected area sizes

Status Register content			Memory content	
BP2 Bit	BP1 Bit	BP0 Bit	Protected area	Unprotected area
0	0	0	none	All sectors ⁽¹⁾ (128 sectors: 0 to 127)
0	0	1	Upper 64th (2 sectors: 126 and 127)	Lower 63/64ths (126 sectors: 0 to 125)
0	1	0	Upper 32nd (4 sectors: 124 to 127)	Lower 31/32nds (124 sectors: 0 to 123)
0	1	1	Upper sixteenth (8 sectors: 120 to 127)	Lower 15/16ths (120 sectors: 0 to 119)
1	0	0	Upper eighth (16 sectors: 112 to 127)	Lower seven-eighths (112 sectors: 0 to 111)
1	0	1	Upper quarter (32 sectors: 96 to 127)	Lower three-quarters (96 sectors: 0 to 95)
1	1	0	Upper half (64 sectors: 64 to 127)	Lower half (64 sectors: 0 to 63)
1	1	1	All sectors (128 sectors: 0 to 127)	none

1. The device is ready to accept a Bulk Erase instruction, if and only if, all Block Protect (BP2, BP1, BP0) are 0.

4.8 Hold Condition

The Hold ($\overline{\text{HOLD}}$) signal is used to pause any serial communications with the device without resetting the clocking sequence. However, taking this signal Low does not terminate any Write Status Register, Program or Erase cycle that is currently in progress.

To enter the Hold condition, the device must be selected, with Chip Select ($\overline{\text{S}}$) Low.

The Hold condition starts on the falling edge of the Hold ($\overline{\text{HOLD}}$) signal, provided that this coincides with Serial Clock (C) being Low (as shown in [Figure 6](#)).

The Hold condition ends on the rising edge of the Hold ($\overline{\text{HOLD}}$) signal, provided that this coincides with Serial Clock (C) being Low.

If the falling edge does not coincide with Serial Clock (C) being Low, the Hold condition starts after Serial Clock (C) next goes Low. Similarly, if the rising edge does not coincide with Serial Clock (C) being Low, the Hold condition ends after Serial Clock (C) next goes Low. (This is shown in [Figure 6](#)).

During the Hold condition, the Serial Data Output (Q) is high impedance, and Serial Data Input (D) and Serial Clock (C) are Don't Care.

Normally, the device is kept selected, with Chip Select ($\overline{\text{S}}$) driven Low, for the whole duration of the Hold condition. This is to ensure that the state of the internal logic remains unchanged from the moment of entering the Hold condition.

If Chip Select ($\overline{\text{S}}$) goes High while the device is in the Hold condition, this has the effect of resetting the internal logic of the device. To restart communication with the device, it is necessary to drive Hold ($\overline{\text{HOLD}}$) High, and then to drive Chip Select ($\overline{\text{S}}$) Low. This prevents the device from going back to the Hold condition.

Figure 6. Hold condition activation

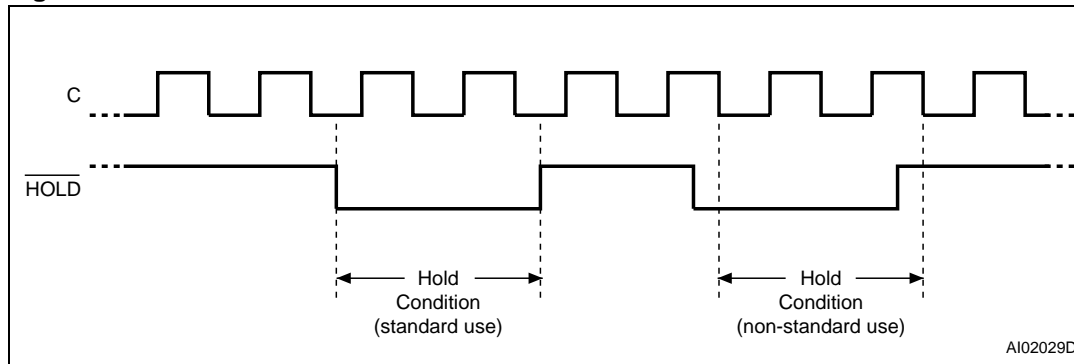

5 Memory organization

The memory is organized as:

- 8388608 bytes (8 bits each)
- 128 sectors (512 Kbits, 65536 bytes each)
- 32768 pages (256 bytes each).

Each page can be individually programmed (bits are programmed from 1 to 0). The device is Sector or Bulk Erasable (bits are erased from 0 to 1) but not Page Erasable.

Figure 7. Block diagram

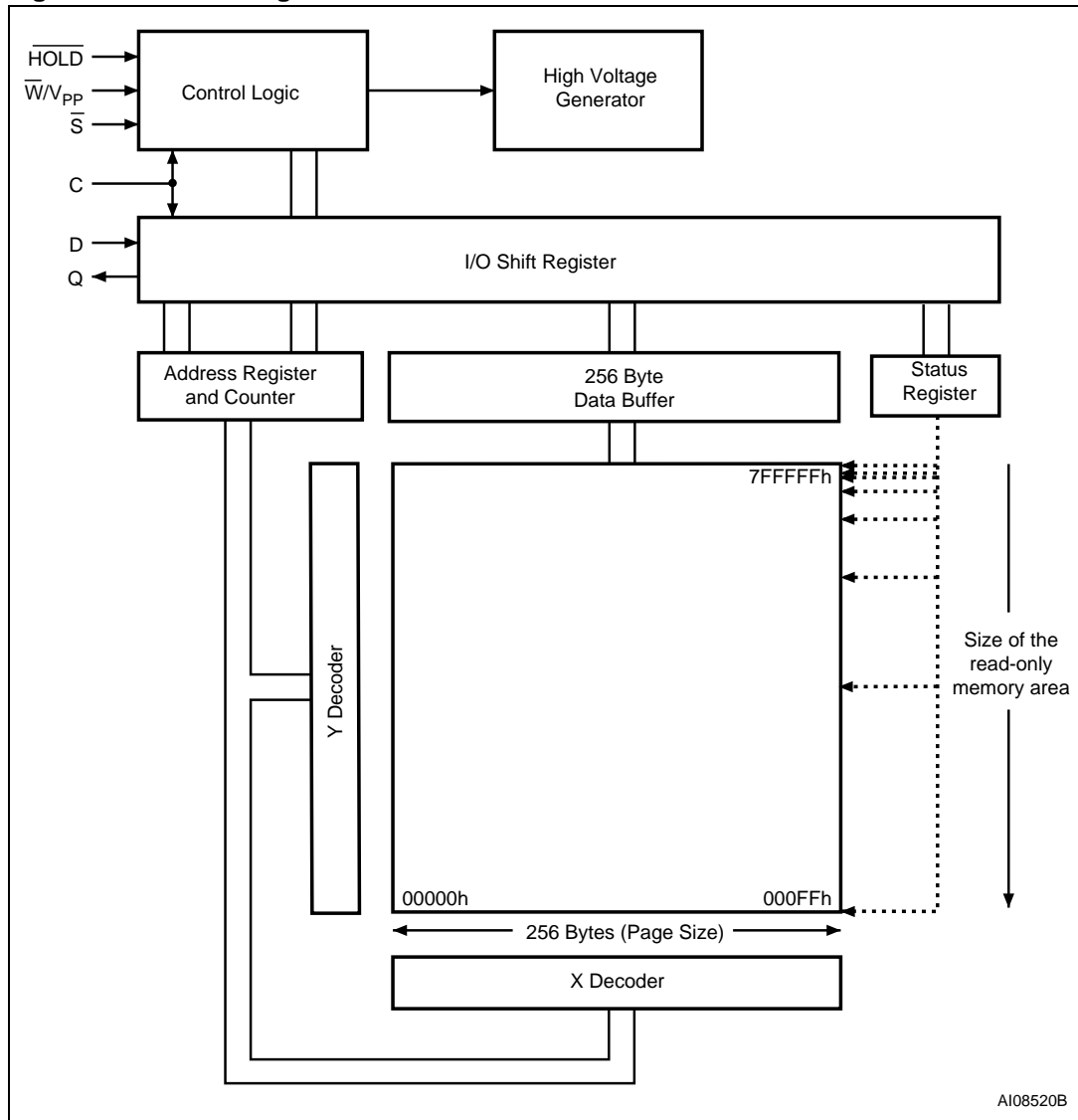

Table 3. Memory organization

Sector	Address range	
127	7F0000h	7FFFFFFh
126	7E0000h	7EFFFFFFh
125	7D0000h	7DFFFFFFh
124	7C0000h	7CFFFFFFh
123	7B0000h	7BFFFFFFh
122	7A0000h	7AFFFFFFh
121	790000h	79FFFFFFh
120	780000h	78FFFFFFh
119	770000h	77FFFFFFh
118	760000h	76FFFFFFh
117	750000h	75FFFFFFh
116	740000h	74FFFFFFh
115	730000h	73FFFFFFh
114	720000h	72FFFFFFh
113	710000h	71FFFFFFh
112	700000h	70FFFFFFh
111	6F0000h	6FFFFFFh
110	6E0000h	6EFFFFFFh
109	6D0000h	6DFFFFFFh
108	6C0000h	6CFFFFFFh
107	6B0000h	6BFFFFFFh
106	6A0000h	6AFFFFFFh
105	690000h	69FFFFFFh
104	680000h	68FFFFFFh
103	670000h	67FFFFFFh
102	660000h	66FFFFFFh
101	650000h	65FFFFFFh
100	640000h	64FFFFFFh
99	630000h	63FFFFFFh
98	620000h	62FFFFFFh
97	610000h	61FFFFFFh
96	600000h	60FFFFFFh
95	5F0000h	5FFFFFFh
94	5E0000h	5EFFFFFFh
93	5D0000h	5DFFFFFFh

Table 3. Memory organization (continued)

Sector	Address range	
	Start	End
92	5C0000h	5CFFFFh
91	5B0000h	5BFFFFh
90	5A0000h	5AFFFFh
89	590000h	59FFFFh
88	580000h	58FFFFh
87	570000h	57FFFFh
86	560000h	56FFFFh
85	550000h	55FFFFh
84	540000h	54FFFFh
83	530000h	53FFFFh
82	520000h	52FFFFh
81	510000h	51FFFFh
80	500000h	50FFFFh
79	4F0000h	4FFFFFh
78	4E0000h	4EFFFFh
77	4D0000h	4DFFFFh
76	4C0000h	4CFFFFh
75	4B0000h	4BFFFFh
74	4A0000h	4AFFFFh
73	490000h	49FFFFh
72	480000h	48FFFFh
71	470000h	47FFFFh
70	460000h	46FFFFh
69	450000h	45FFFFh
68	440000h	44FFFFh
67	430000h	43FFFFh
66	420000h	42FFFFh
65	410000h	41FFFFh
64	400000h	40FFFFh
63	3F0000h	3FFFFFh
62	3E0000h	3EFFFFh
61	3D0000h	3DFFFFh
60	3C0000h	3CFFFFh
59	3B0000h	3BFFFFh
58	3A0000h	3AFFFFh

Table 3. Memory organization (continued)

Sector	Address range	
	Start	End
57	390000h	39FFFFh
56	380000h	38FFFFh
55	370000h	37FFFFh
54	360000h	36FFFFh
53	350000h	35FFFFh
52	340000h	34FFFFh
51	330000h	33FFFFh
50	320000h	32FFFFh
49	310000h	31FFFFh
48	300000h	30FFFFh
47	2F0000h	2FFFFFh
46	2E0000h	2EFFFFh
45	2D0000h	2DFFFFh
44	2C0000h	2CFFFFh
43	2B0000h	2BFFFFh
42	2A0000h	2AFFFFh
41	290000h	29FFFFh
40	280000h	28FFFFh
39	270000h	27FFFFh
38	260000h	26FFFFh
37	250000h	25FFFFh
36	240000h	24FFFFh
35	230000h	23FFFFh
34	220000h	22FFFFh
33	210000h	21FFFFh
32	200000h	20FFFFh
31	1F0000h	1FFFFFh
30	1E0000h	1EFFFFh
29	1D0000h	1DFFFFh
28	1C0000h	1CFFFFh
27	1B0000h	1BFFFFh
26	1A0000h	1AFFFFh
25	190000h	19FFFFh
24	180000h	18FFFFh
23	170000h	17FFFFh

Table 3. Memory organization (continued)

Sector	Address range	
	22	160000h
21	150000h	15FFFFh
20	140000h	14FFFFh
19	130000h	13FFFFh
18	120000h	12FFFFh
17	110000h	11FFFFh
16	100000h	10FFFFh
15	0F0000h	0FFFFh
14	0E0000h	0EFFFFh
13	0D0000h	0DFFFFh
12	0C0000h	0CFFFFh
11	0B0000h	0BFFFFh
10	0A0000h	0AFFFFh
9	090000h	09FFFFh
8	080000h	08FFFFh
7	070000h	07FFFFh
6	060000h	06FFFFh
5	050000h	05FFFFh
4	040000h	04FFFFh
3	030000h	03FFFFh
2	020000h	02FFFFh
1	010000h	01FFFFh
0	000000h	00FFFFh

6 Instructions

All instructions, addresses and data are shifted in and out of the device, most significant bit first.

Serial Data Input (D) is sampled on the first rising edge of Serial Clock (C) after Chip Select (\bar{S}) is driven Low. Then, the one-byte instruction code must be shifted in to the device, most significant bit first, on Serial Data Input (D), each bit being latched on the rising edges of Serial Clock (C).

The instruction set is listed in [Table 4](#).

Every instruction sequence starts with a one-byte instruction code. Depending on the instruction, this might be followed by address bytes, or by data bytes, or by both or none.

In the case of a Read Data Bytes (READ), Read Data Bytes at Higher Speed (Fast_Read), Read Status Register (RDSR), Read Identification (RDID) or Read Electronic Signature (RES) instruction, the shifted-in instruction sequence is followed by a data-out sequence. Chip Select (\bar{S}) can be driven High after any bit of the data-out sequence is being shifted out.

In the case of a Page Program (PP), Sector Erase (SE), Bulk Erase (BE), Write Status Register (WRSR), Write Enable (WREN) or Write Disable (WRDI), Chip Select (\bar{S}) must be driven High exactly at a byte boundary, otherwise the instruction is rejected, and is not executed. That is, Chip Select (\bar{S}) must driven High when the number of clock pulses after Chip Select (\bar{S}) being driven Low is an exact multiple of eight.

All attempts to access the memory array during a Write Status Register cycle, Program cycle or Erase cycle are ignored, and the internal Write Status Register cycle, Program cycle or Erase cycle continues unaffected.

Table 4. Instruction set

Instruction	Description	One-byte instruction code		Address bytes	Dummy bytes	Data bytes
WREN	Write Enable	0000 0110	06h	0	0	0
WRDI	Write Disable	0000 0100	04h	0	0	0
RDID	Read Identification	1001 1111	9Fh	0	0	1 to 3
RDSR	Read Status Register	0000 0101	05h	0	0	1 to ∞
WRSR	Write Status Register	0000 0001	01h	0	0	1
READ	Read Data Bytes	0000 0011	03h	3	0	1 to ∞
FAST_READ	Read Data Bytes at Higher Speed	0000 1011	0Bh	3	1	1 to ∞
PP	Page Program	0000 0010	02h	3	0	1 to 256
SE	Sector Erase	1101 1000	D8h	3	0	0
BE	Bulk Erase	1100 0111	C7h	0	0	0
RES	Read Electronic Signature	1010 1011	ABh	0	3	1 to ∞

6.1 Write Enable (WREN)

The Write Enable (WREN) instruction ([Figure 8](#)) sets the Write Enable Latch (WEL) bit.

The Write Enable Latch (WEL) bit must be set prior to every Page Program (PP), Sector Erase (SE), Bulk Erase (BE) and Write Status Register (WRSR) instruction.

The Write Enable (WREN) instruction is entered by driving Chip Select (\overline{S}) Low, sending the instruction code, and then driving Chip Select (\overline{S}) High.

Figure 8. Write Enable (WREN) instruction sequence

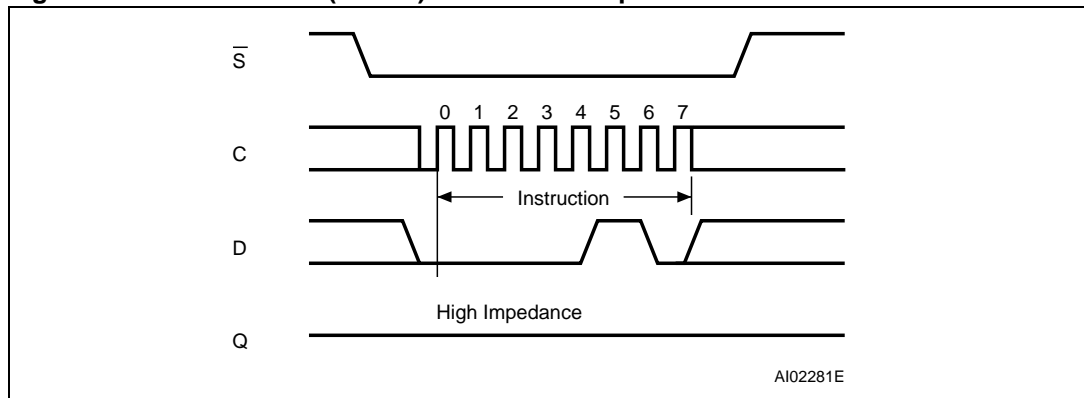

6.2 Write Disable (WRDI)

The Write Disable (WRDI) instruction (*Figure 9*) resets the Write Enable Latch (WEL) bit.

The Write Disable (WRDI) instruction is entered by driving Chip Select (\bar{S}) Low, sending the instruction code, and then driving Chip Select (\bar{S}) High.

The Write Enable Latch (WEL) bit is reset under the following conditions:

- Power-up
- Write Disable (WRDI) instruction completion
- Write Status Register (WRSR) instruction completion
- Page Program (PP) instruction completion
- Sector Erase (SE) instruction completion
- Bulk Erase (BE) instruction completion

Figure 9. Write Disable (WRDI) instruction sequence

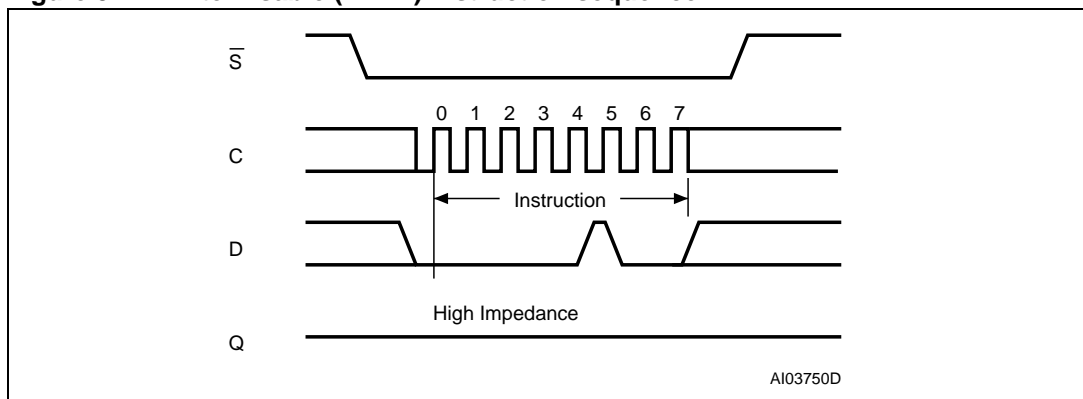

6.3 Read Identification (RDID)

The read identification (RDID) instruction allows to read the device identification data:

- Manufacturer identification (1 byte)
- Device identification (2 bytes)
- A unique ID code (UID) (17 bytes, of which 16 available upon customer request).⁽¹⁾

The manufacturer identification is assigned by JEDEC, and has the value 20h for Numonyx. The device identification is assigned by the device manufacturer, and indicates the memory type in the first byte (20h), and the memory capacity of the device in the second byte (17h). The UID contains the length of the following data in the first byte (set to 10h) and 16 bytes of the optional customized factory data (CFD) content. The CFD bytes are read-only and can be programmed with customers data upon their demand. If the customers do not make requests, the devices are shipped with all the CFD bytes programmed to zero (00h).

Any read identification (RDID) instruction while an erase or program cycle is in progress, is not decoded, and has no effect on the cycle that is in progress.

The read identification (RDID) instruction should not be issued while the device is in deep power-down mode.

The device is first selected by driving Chip Select (\overline{S}) Low. Then, the 8-bit instruction code for the instruction is shifted in. After this, the 24-bit device identification, stored in the memory, the 8-bit CFD length followed by 16 bytes of CFD content will be shifted out on serial data output (DQ1). Each bit is shifted out during the falling edge of Serial Clock (C). The instruction sequence is shown in [Figure 10](#).

The read identification (RDID) instruction is terminated by driving Chip Select (\overline{S}) High at any time during data output. When Chip Select (\overline{S}) is driven High, the device is put in the standby power mode. Once in the standby power mode, the device waits to be selected so that it can receive, decode, and execute instructions.

Table 5. Read identification (RDID) data-out sequence

Manufacturer identification	Device identification		UID	
	Memory type	Memory capacity	CFD length	CFD content
20h	20h	17h	10h	16 bytes

1. The UID feature is available only for process technology T9HX devices, identified by process identification digit "4" in the device marking.

Figure 10. Read Identification (RDID) instruction sequence and data-out sequence

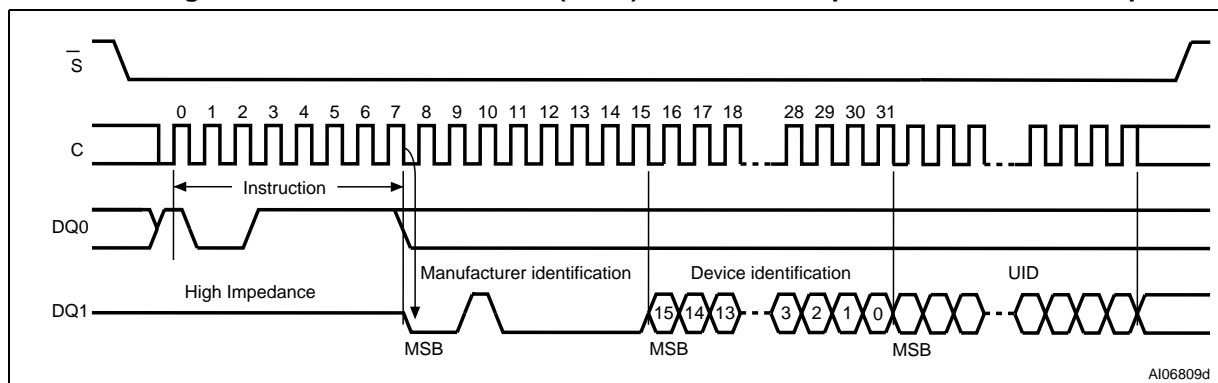

6.4 Read Status Register (RDSR)

The Read Status Register (RDSR) instruction allows the Status Register to be read. The Status Register may be read at any time, even while a Program, Erase or Write Status Register cycle is in progress. When one of these cycles is in progress, it is recommended to check the Write In Progress (WIP) bit before sending a new instruction to the device. It is also possible to read the Status Register continuously, as shown in [Figure 11](#).

Table 6. Status Register format

b7							b0
SRWD	0	0	BP2	BP1	BP0	WEL	WIP
Status Register Write Protect				Block Protect Bits		Write Enable Latch Bit	Write In Progress Bit

The status and control bits of the Status Register are as follows:

6.4.1 WIP bit

The Write In Progress (WIP) bit indicates whether the memory is busy with a Write Status Register, Program or Erase cycle. When set to 1, such a cycle is in progress, when reset to 0 no such cycle is in progress.

6.4.2 WEL bit

The Write Enable Latch (WEL) bit indicates the status of the internal Write Enable Latch. When set to 1 the internal Write Enable Latch is set, when set to 0 the internal Write Enable Latch is reset and no Write Status Register, Program or Erase instruction is accepted.

6.4.3 BP2, BP1, BP0 bits

The Block Protect (BP2, BP1, BP0) bits are non-volatile. They define the size of the area to be software protected against Program and Erase instructions. These bits are written with

the Write Status Register (WRSR) instruction. When one or more of the Block Protect (BP2, BP1, BP0) bits is set to 1, the relevant memory area (as defined in [Table 2](#)) becomes protected against Page Program (PP) and Sector Erase (SE) instructions. The Block Protect (BP2, BP1, BP0) bits can be written provided that the Hardware Protected mode has not been set. The Bulk Erase (BE) instruction is executed if, and only if, all Block Protect (BP2, BP1, BP0) bits are 0.

6.4.4 SRWD bit

The Status Register Write Disable (SRWD) bit is operated in conjunction with the Write Protect (\overline{W}/V_{PP}) signal. The Status Register Write Disable (SRWD) bit and Write Protect (\overline{W}/V_{PP}) signal allow the device to be put in the Hardware Protected mode (when the Status Register Write Disable (SRWD) bit is set to 1, and Write Protect (\overline{W}/V_{PP}) is driven Low). In this mode, the non-volatile bits of the Status Register (SRWD, BP2, BP1, BP0) become read-only bits and the Write Status Register (WRSR) instruction is no longer accepted for execution.

Figure 11. Read Status Register (RDSR) instruction sequence and data-out sequence

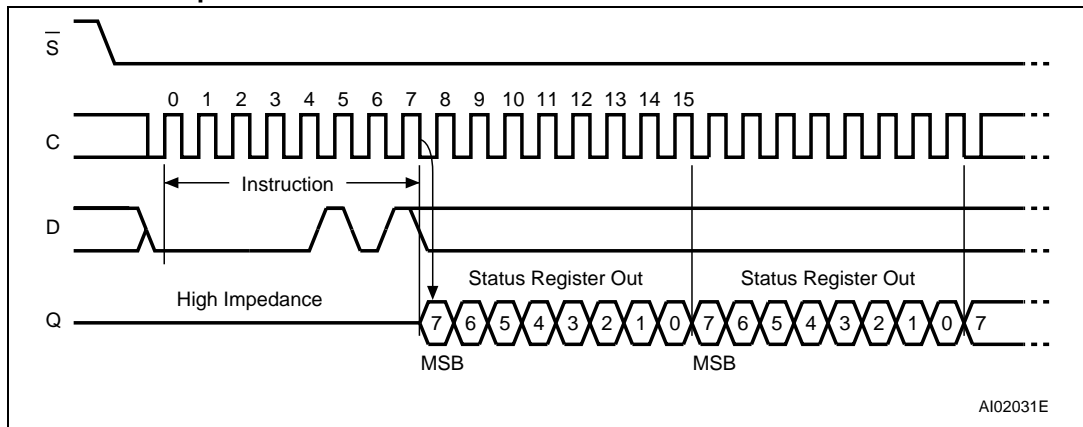

6.5 Write Status Register (WRSR)

The Write Status Register (WRSR) instruction allows new values to be written to the Status Register. Before it can be accepted, a Write Enable (WREN) instruction must previously have been executed. After the Write Enable (WREN) instruction has been decoded and executed, the device sets the Write Enable Latch (WEL).

The Write Status Register (WRSR) instruction is entered by driving Chip Select (\overline{S}) Low, followed by the instruction code and the data byte on Serial Data Input (D).

The instruction sequence is shown in [Figure 12](#).

The Write Status Register (WRSR) instruction has no effect on b6, b5, b1 and b0 of the Status Register. b6 and b5 are always read as 0.

Chip Select (\overline{S}) must be driven High after the eighth bit of the data byte has been latched in. If not, the Write Status Register (WRSR) instruction is not executed. As soon as Chip Select (\overline{S}) is driven High, the self-timed Write Status Register cycle (whose duration is t_{W}) is initiated. While the Write Status Register cycle is in progress, the Status Register may still be read to check the value of the Write In Progress (WIP) bit. The Write In Progress (WIP) bit is 1 during the self-timed Write Status Register cycle, and is 0 when it is completed. When the cycle is completed, the Write Enable Latch (WEL) is reset.

The Write Status Register (WRSR) instruction allows the user to change the values of the Block Protect (BP2, BP1, BP0) bits, to define the size of the area that is to be treated as read-only, as defined in [Table 2](#). The Write Status Register (WRSR) instruction also allows the user to set or reset the Status Register Write Disable (SRWD) bit in accordance with the Write Protect (\overline{W}/V_{PP}) signal. The Status Register Write Disable (SRWD) bit and Write Protect (\overline{W}/V_{PP}) signal allow the device to be put in the Hardware Protected Mode (HPM). The Write Status Register (WRSR) instruction is not executed once the Hardware Protected Mode (HPM) is entered.

Table 7. Protection modes

\overline{W}/V_{PP} signal	SRWD bit	Mode	Write Protection of the Status Register	Memory content	
				Protected area ⁽¹⁾	Unprotected area ⁽¹⁾
1	0	Software Protected (SPM)	Status Register is Writable (if the WREN instruction has set the WEL bit)	Protected against Page Program, Sector Erase and Bulk Erase	Ready to accept Page Program and Sector Erase instructions
0	0		The values in the SRWD, BP2, BP1 and BP0 bits can be changed		
1	1	Hardware Protected (HPM)	Status Register is Hardware write protected	Protected against Page Program, Sector Erase and Bulk Erase	Ready to accept Page Program and Sector Erase instructions
0	1		The values in the SRWD, BP2, BP1 and BP0 bits cannot be changed		

1. As defined by the values in the Block Protect (BP2, BP1, BP0) bits of the Status Register, as shown in [Table 2](#).

The protection features of the device are summarized in [Table 7](#).

When the Status Register Write Disable (SRWD) bit of the Status Register is 0 (its initial delivery state), it is possible to write to the Status Register provided that the Write Enable Latch (WEL) bit has previously been set by a Write Enable (WREN) instruction, regardless of the whether Write Protect (\overline{W}/V_{PP}) is driven High or Low.

When the Status Register Write Disable (SRWD) bit of the Status Register is set to 1, two cases need to be considered, depending on the state of Write Protect (\overline{W}/V_{PP}):

- If Write Protect (\overline{W}/V_{PP}) is driven High, it is possible to write to the Status Register provided that the Write Enable Latch (WEL) bit has previously been set by a Write Enable (WREN) instruction.
- If Write Protect (\overline{W}/V_{PP}) is driven Low, it is *not* possible to write to the Status Register *even* if the Write Enable Latch (WEL) bit has previously been set by a Write Enable (WREN) instruction. (Attempts to write to the Status Register are rejected, and are not accepted for execution). As a consequence, all the data bytes in the memory area that are software protected (SPM) by the Block Protect (BP2, BP1, BP0) bits of the Status Register, are also hardware protected against data modification.

Regardless of the order of the two events, the Hardware Protected Mode (HPM) can be entered:

- by setting the Status Register Write Disable (SRWD) bit after driving Write Protect (\overline{W}/V_{PP}) Low
- or by driving Write Protect (\overline{W}/V_{PP}) Low after setting the Status Register Write Disable (SRWD) bit.

The only way to exit the Hardware Protected Mode (HPM) once entered is to pull Write Protect/ (\overline{W}/V_{PP}) High.

If Write Protect/ (\overline{W}/V_{PP}) is permanently tied High, the Hardware Protected Mode (HPM) can never be activated, and only the Software Protected Mode (SPM), using the Block Protect (BP2, BP1, BP0) bits of the Status Register, can be used.

Figure 12. Write Status Register (WRSR) instruction sequence

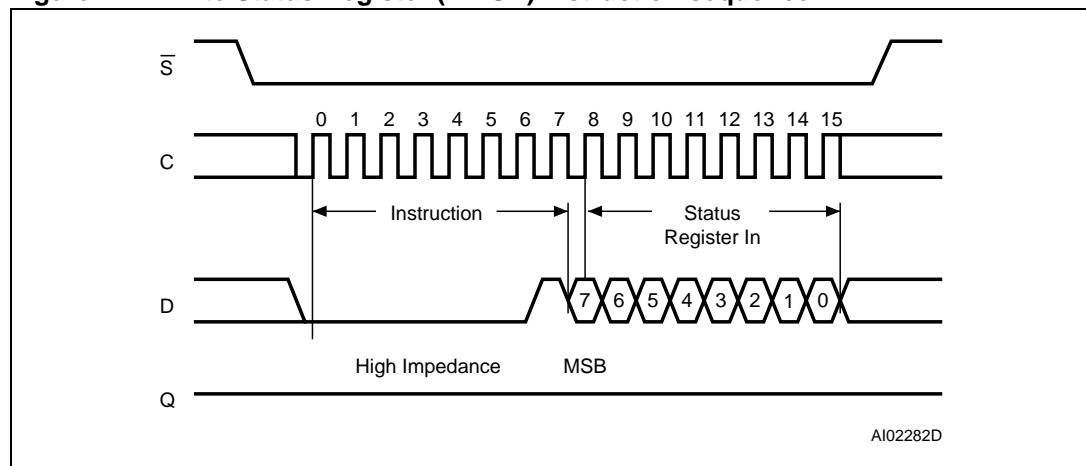

6.6 Read Data Bytes (READ)

The device is first selected by driving Chip Select (\overline{S}) Low. The instruction code for the Read Data Bytes (READ) instruction is followed by a 3-byte address (A23-A0), each bit being latched-in during the rising edge of Serial Clock (C). Then the memory contents, at that address, is shifted out on Serial Data Output (Q), each bit being shifted out, at a maximum frequency f_R , during the falling edge of Serial Clock (C).

The instruction sequence is shown in *Figure 13*.

The first byte addressed can be at any location. The address is automatically incremented to the next higher address after each byte of data is shifted out. The whole memory can, therefore, be read with a single Read Data Bytes (READ) instruction. When the highest address is reached, the address counter rolls over to 000000h, allowing the read sequence to be continued indefinitely.

The Read Data Bytes (READ) instruction is terminated by driving Chip Select (\overline{S}) High. Chip Select (\overline{S}) can be driven High at any time during data output. Any Read Data Bytes (READ) instruction, while an Erase, Program or Write cycle is in progress, is rejected without having any effects on the cycle that is in progress.

Figure 13. Read Data Bytes (READ) instruction sequence and data-out sequence

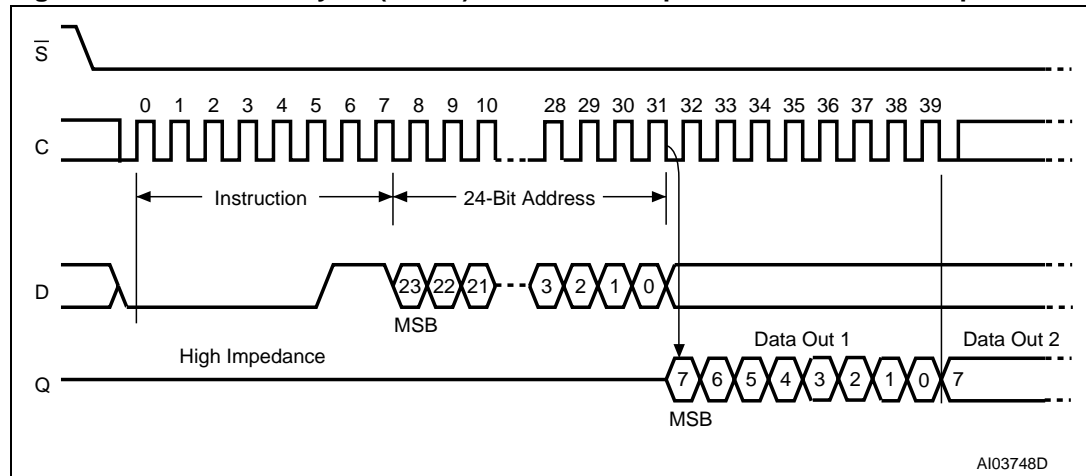

1. Address bit A23 is Don't Care.

6.7 Read Data Bytes at Higher Speed (FAST_READ)

The device is first selected by driving Chip Select (\overline{S}) Low. The instruction code for the Read Data Bytes at Higher Speed (FAST_READ) instruction is followed by a 3-byte address (A23-A0) and a dummy byte, each bit being latched-in during the rising edge of Serial Clock (C). Then the memory contents, at that address, is shifted out on Serial Data Output (Q), each bit being shifted out, at a maximum frequency f_C , during the falling edge of Serial Clock (C).

The instruction sequence is shown in [Figure 14](#).

The first byte addressed can be at any location. The address is automatically incremented to the next higher address after each byte of data is shifted out. The whole memory can, therefore, be read with a single Read Data Bytes at Higher Speed (FAST_READ) instruction. When the highest address is reached, the address counter rolls over to 000000h, allowing the read sequence to be continued indefinitely.

The Read Data Bytes at Higher Speed (FAST_READ) instruction is terminated by driving Chip Select (\overline{S}) High. Chip Select (\overline{S}) can be driven High at any time during data output. Any Read Data Bytes at Higher Speed (FAST_READ) instruction, while an Erase, Program or Write cycle is in progress, is rejected without having any effects on the cycle that is in progress.

Figure 14. Read Data Bytes at Higher Speed (FAST_READ) instruction and data-out sequence

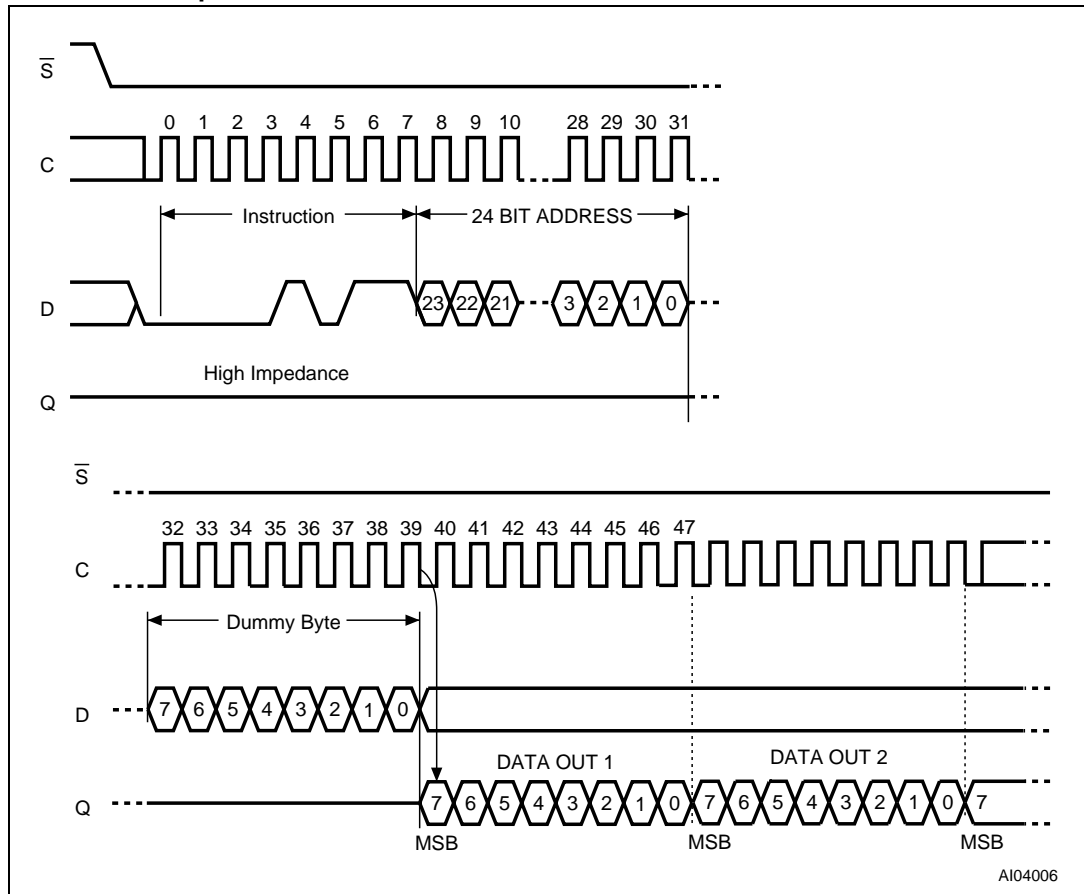

1. Address bit A23 is Don't Care.

6.8 Page Program (PP)

The Page Program (PP) instruction allows bytes to be programmed in the memory (changing bits from 1 to 0). Before it can be accepted, a Write Enable (WREN) instruction must previously have been executed. After the Write Enable (WREN) instruction has been decoded, the device sets the Write Enable Latch (WEL).

The Page Program (PP) instruction is entered by driving Chip Select (\bar{S}) Low, followed by the instruction code, three address bytes and at least one data byte on Serial Data Input (D). If the 8 least significant address bits (A7-A0) are not all zero, all transmitted data that goes beyond the end of the current page are programmed from the start address of the same page (from the address whose 8 least significant bits (A7-A0) are all zero). Chip Select (\bar{S}) must be driven Low for the entire duration of the sequence.

The instruction sequence is shown in [Figure 15](#).

If more than 256 bytes are sent to the device, previously latched data are discarded and the last 256 data bytes are guaranteed to be programmed correctly within the same page. If less than 256 Data bytes are sent to device, they are correctly programmed at the requested addresses without having any effects on the other bytes of the same page.

For optimized timings, it is recommended to use the Page Program (PP) instruction to program all consecutive targeted Bytes in a single sequence versus using several Page Program (PP) sequences with each containing only a few Bytes (see [Table 16: AC characteristics](#)).

Chip Select (\bar{S}) must be driven High after the eighth bit of the last data byte has been latched in, otherwise the Page Program (PP) instruction is not executed.

As soon as Chip Select (\bar{S}) is driven High, the self-timed Page Program cycle (whose duration is t_{pp}) is initiated. While the Page Program cycle is in progress, the Status Register may be read to check the value of the Write In Progress (WIP) bit. The Write In Progress (WIP) bit is 1 during the self-timed Page Program cycle, and is 0 when it is completed. At some unspecified time before the cycle is completed, the Write Enable Latch (WEL) bit is reset.

A Page Program (PP) instruction applied to a page which is protected by the Block Protect (BP2, BP1, BP0) bits (see [Table 2](#) and [Table 3](#)) is not executed.

Figure 15. Page Program (PP) instruction sequence

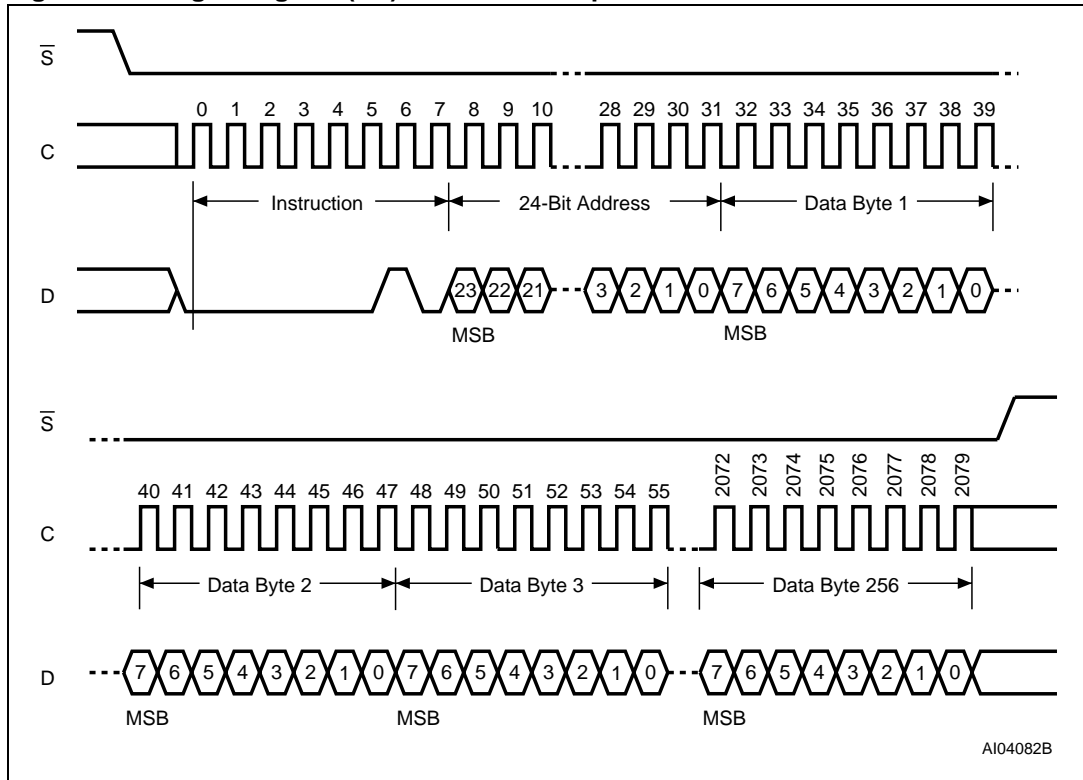

6.9 Sector Erase (SE)

The Sector Erase (SE) instruction sets to 1 (FFh) all bits inside the chosen sector. Before it can be accepted, a Write Enable (WREN) instruction must previously have been executed. After the Write Enable (WREN) instruction has been decoded, the device sets the Write Enable Latch (WEL).

The Sector Erase (SE) instruction is entered by driving Chip Select (\bar{S}) Low, followed by the instruction code, and three address bytes on Serial Data Input (D). Any address inside the Sector (see [Table 3](#)) is a valid address for the Sector Erase (SE) instruction. Chip Select (\bar{S}) must be driven Low for the entire duration of the sequence.

The instruction sequence is shown in [Figure 16](#).

Chip Select (\bar{S}) must be driven High after the eighth bit of the last address byte has been latched in, otherwise the Sector Erase (SE) instruction is not executed. As soon as Chip Select (\bar{S}) is driven High, the self-timed Sector Erase cycle (whose duration is t_{SE}) is initiated. While the Sector Erase cycle is in progress, the Status Register may be read to check the value of the Write In Progress (WIP) bit. The Write In Progress (WIP) bit is 1 during the self-timed Sector Erase cycle, and is 0 when it is completed. At some unspecified time before the cycle is completed, the Write Enable Latch (WEL) bit is reset.

A Sector Erase (SE) instruction applied to a page which is protected by the Block Protect (BP2, BP1, BP0) bits (see [Table 2](#) and [Table 3](#)) is not executed.

Figure 16. Sector Erase (SE) instruction sequence

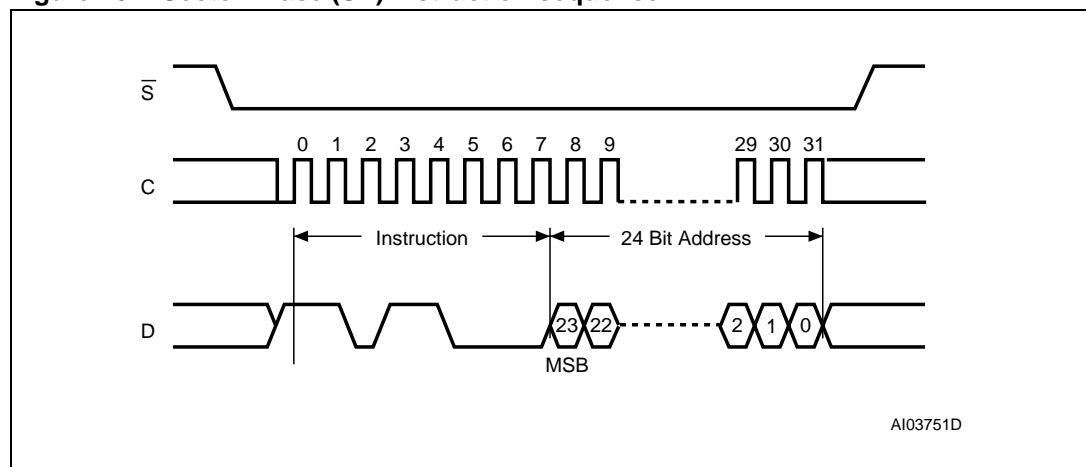

1. Address bit A23 is Don't Care.

6.10 Bulk Erase (BE)

The Bulk Erase (BE) instruction sets all bits to 1 (FFh). Before it can be accepted, a Write Enable (WREN) instruction must previously have been executed. After the Write Enable (WREN) instruction has been decoded, the device sets the Write Enable Latch (WEL).

The Bulk Erase (BE) instruction is entered by driving Chip Select (\bar{S}) Low, followed by the instruction code on Serial Data Input (D). Chip Select (\bar{S}) must be driven Low for the entire duration of the sequence.

The instruction sequence is shown in [Figure 17](#).

Chip Select (\bar{S}) must be driven High after the eighth bit of the instruction code has been latched in, otherwise the Bulk Erase instruction is not executed. As soon as Chip Select (\bar{S}) is driven High, the self-timed Bulk Erase cycle (whose duration is t_{BE}) is initiated. While the Bulk Erase cycle is in progress, the Status Register may be read to check the value of the Write In Progress (WIP) bit. The Write In Progress (WIP) bit is 1 during the self-timed Bulk Erase cycle, and is 0 when it is completed. At some unspecified time before the cycle is completed, the Write Enable Latch (WEL) bit is reset.

The Bulk Erase (BE) instruction is executed only if all Block Protect (BP2, BP1, BP0) bits are 0. The Bulk Erase (BE) instruction is ignored if one, or more, sectors are protected.

Figure 17. Bulk Erase (BE) instruction sequence

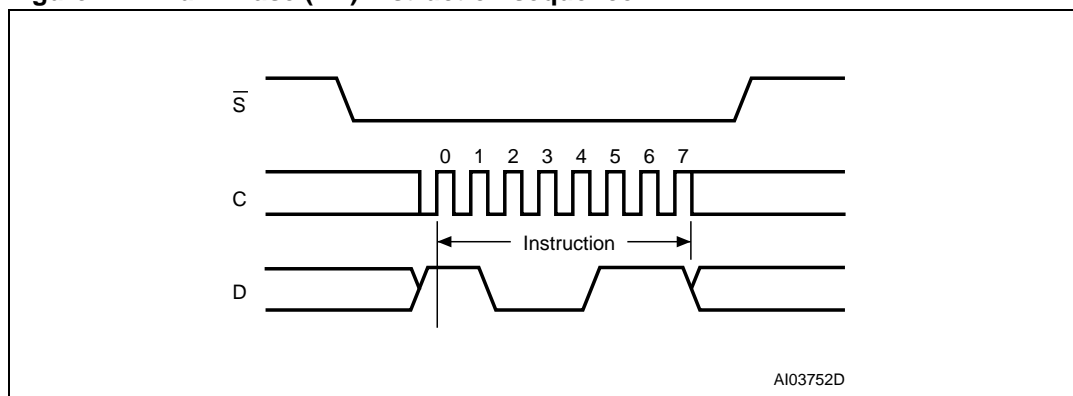

6.11 Read Electronic Signature (RES)

The instruction is used to read, on Serial Data Output (Q), the old-style 8-bit Electronic Signature, whose value for the M25P64 is 16h.

Please note that this is not the same as, or even a subset of, the JEDEC 16-bit Electronic Signature that is read by the Read Identifier (RDID) instruction. The old-style Electronic Signature is supported for reasons of backward compatibility, only, and should not be used for new designs. New designs should, instead, make use of the JEDEC 16-bit Electronic Signature, and the Read Identifier (RDID) instruction.

The device is first selected by driving Chip Select (\bar{S}) Low. The instruction code is followed by 3 dummy bytes, each bit being latched-in on Serial Data Input (D) during the rising edge of Serial Clock (C). Then, the old-style 8-bit Electronic Signature, stored in the memory, is shifted out on Serial Data Output (Q), each bit being shifted out during the falling edge of Serial Clock (C).

The instruction sequence is shown in [Figure 18](#).

The Read Electronic Signature (RES) instruction is terminated by driving Chip Select (\bar{S}) High after the Electronic Signature has been read at least once. Sending additional clock cycles on Serial Clock (C), while Chip Select (\bar{S}) is driven Low, cause the Electronic Signature to be output repeatedly.

When Chip Select (\bar{S}) is driven High, the device is put in the Standby Power mode. Once in the Standby Power mode, the device waits to be selected, so that it can receive, decode and execute instructions.

Driving Chip Select (\bar{S}) High after the 8-bit instruction byte has been received by the device, but before the whole of the 8-bit Electronic Signature has been transmitted for the first time, still ensures that the device is put into Standby Power mode. Once in the Standby Power mode, the device waits to be selected, so that it can receive, decode and execute instructions.

Figure 18. Read Electronic Signature (RES) instruction sequence and data-out sequence

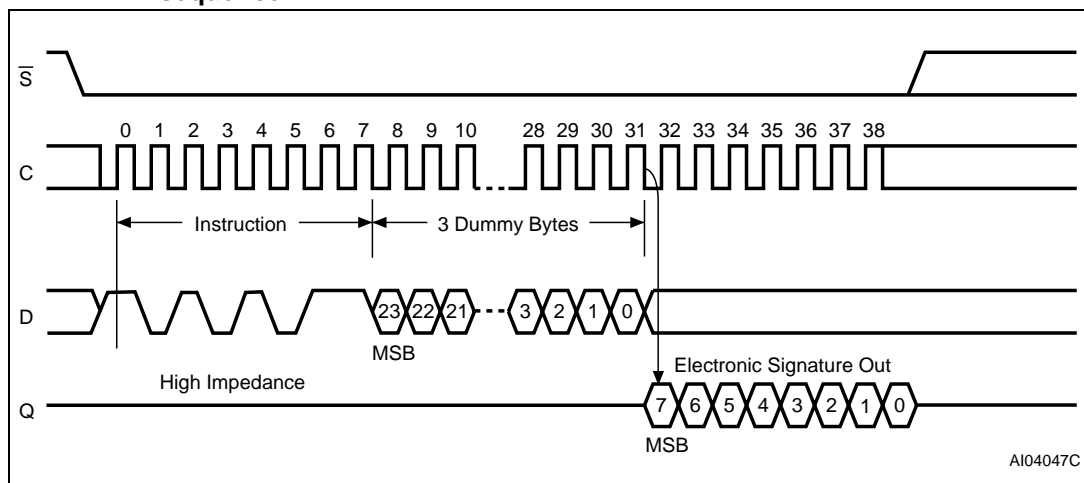

1. The value of the 8-bit Electronic Signature, for the M25P64, is 16h.

7 Power-up and Power-down

At Power-up and Power-down, the device must not be selected (that is Chip Select (\overline{S}) must follow the voltage applied on V_{CC}) until V_{CC} reaches the correct value:

- $V_{CC}(\text{min})$ at Power-up, and then for a further delay of t_{VSL}
- V_{SS} at Power-down

A safe configuration is provided in [Section 3: SPI modes](#).

To avoid data corruption and inadvertent write operations during Power-up, a Power On Reset (POR) circuit is included. The logic inside the device is held reset while V_{CC} is less than the Power On Reset (POR) threshold voltage, V_{WI} – all operations are disabled, and the device does not respond to any instruction.

Moreover, the device ignores all Write Enable (WREN), Page Program (PP), Sector Erase (SE), Bulk Erase (BE) and Write Status Register (WRSR) instructions until a time delay of t_{PUW} has elapsed after the moment that V_{CC} rises above the V_{WI} threshold. However, the correct operation of the device is not guaranteed if, by this time, V_{CC} is still below $V_{CC}(\text{min})$. No Write Status Register, Program or Erase instructions should be sent until the later of:

- t_{PUW} after V_{CC} passed the V_{WI} threshold
- t_{VSL} after V_{CC} passed the $V_{CC}(\text{min})$ level

These values are specified in [Table 8](#).

If the delay, t_{VSL} , has elapsed, after V_{CC} has risen above $V_{CC}(\text{min})$, the device can be selected for READ instructions even if the t_{PUW} delay is not yet fully elapsed.

At Power-up, the device is in the following state:

- The device is in the Standby Power mode
- The Write Enable Latch (WEL) bit is reset
- The Write In Progress (WIP) bit is reset

Normal precautions must be taken for supply rail decoupling, to stabilize the V_{CC} supply. Each device in a system should have the V_{CC} rail decoupled by a suitable capacitor close to the package pins. (Generally, this capacitor is of the order of 100 nF).

At Power-down, when V_{CC} drops from the operating voltage, to below the Power On Reset (POR) threshold voltage, V_{WI} , all operations are disabled and the device does not respond to any instruction. (The designer needs to be aware that if a Power-down occurs while a Write, Program or Erase cycle is in progress, some data corruption can result.).

Power up sequencing for Fast program/erase mode: V_{CC} should attain V_{CCMIN} before V_{PPH} is applied.

Figure 19. Power-up timing

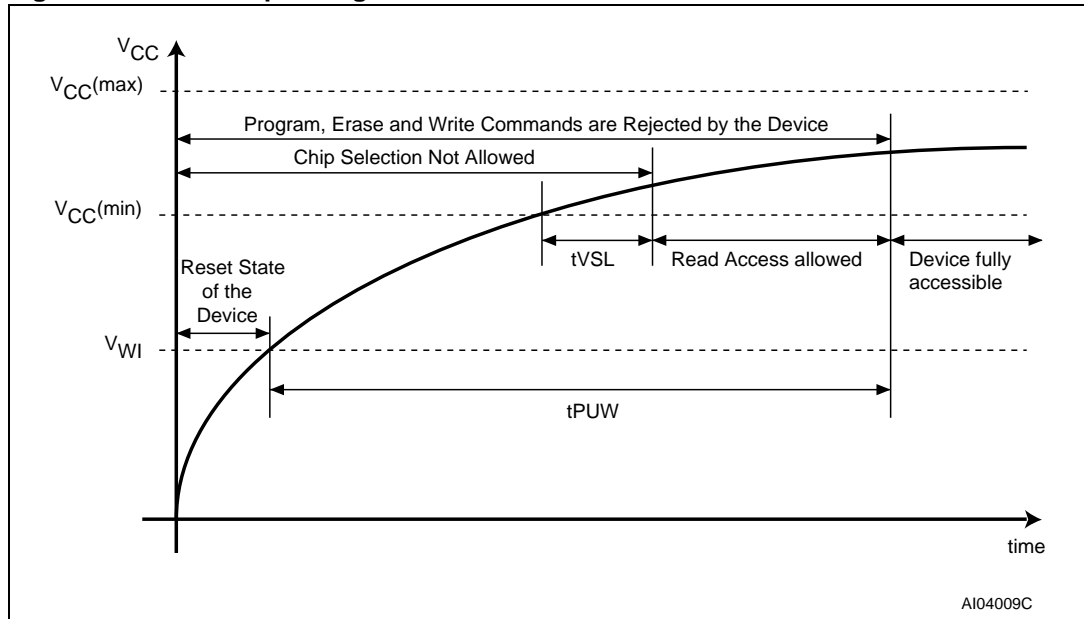

Table 8. Power-Up timing and VWI threshold

Symbol	Parameter	Min.	Max.	Unit
$t_{VSL}^{(1)}$	$V_{CC(min)}$ to \bar{S} low	30		μs
$t_{PUW}^{(1)}$	Time delay to Write instruction	1	10	ms
$V_{WI}^{(1)}$	Write Inhibit Voltage	1.5	2.5	V

1. These parameters are characterized only.

8 Initial delivery state

The device is delivered with the memory array erased: all bits are set to 1 (each byte contains FFh). The Status Register contains 00h (all Status Register bits are 0).

9 Maximum rating

Stressing the device outside the ratings listed in [Table 9](#) may cause permanent damage to the device. These are stress ratings only, and operation of the device at these, or any other conditions outside those indicated in the Operating sections of this specification, is not implied. Exposure to Absolute Maximum Rating conditions for extended periods may affect device reliability. Refer also to the Numonyx SURE Program and other relevant quality documents.

Table 9. Absolute maximum ratings

Symbol	Parameter	Min.	Max.	Unit
T _{STG}	Storage Temperature	-65	150	°C
T _{LEAD}	Lead Temperature during Soldering	See note ⁽¹⁾		°C
V _{IO}	Input and Output Voltage (with respect to Ground)	-0.5	V _{CC} + 0.6	V
V _{CC}	Supply Voltage	-0.2	4.0	V
V _{PP}	Fast Program/Erase Voltage ⁽²⁾	-0.2	10.0	V
V _{ESD}	Electrostatic Discharge Voltage (Human Body model) ⁽³⁾	-2000	2000	V

1. Compliant with JEDEC Std J-STD-020C (for small body, Sn-Pb or Pb assembly) and the European directive on Restrictions on Hazardous Substances (RoHS) 2002/95/EU
2. Avoid applying VPPH to the W/VPP pin during Bulk Erase with process technology T9HX devices, identified by process identification digit "4" in the device marking.
3. JEDEC Std JESD22-A114A (C1=100 pF, R1 = 1500 Ω, R2 = 500 Ω).

10 DC and AC parameters

This section summarizes the operating and measurement conditions, and the DC and AC characteristics of the device. The parameters in the DC and AC Characteristic tables that follow are derived from tests performed under the Measurement Conditions summarized in the relevant tables. Designers should check that the operating conditions in their circuit match the measurement conditions when relying on the quoted parameters.

Table 10. Operating conditions

Symbol	Parameter	Min.	Typ	Max.	Unit
V_{CC}	Supply Voltage	2.7		3.6	V
V_{PPH}	Supply Voltage on \overline{W}/V_{PP} pin for Fast Program/Erase mode ⁽¹⁾	8.5		9.5	V
T_A	Ambient Operating Temperature (grade 6) ⁽²⁾	-40		85	°C
T_A	Ambient Operating Temperature (grade 3) ⁽³⁾	-40		125	°C
T_{AVPP}	Ambient Operating Temperature for Fast Program/Erase mode	15	25	35	°C

1. Avoid applying V_{PPH} to the \overline{W}/V_{PP} pin during Bulk Erase with process technology T9HX devices, identified by process identification digit "4" in the device marking.
2. "Autograde 6 and Standard parts (grade 6) are tested to 85 °C, but the Autograde 6 will follow the HRCF.
3. Autograde 3 is tested to 125 °C.

Table 11. Data Retention and Endurance

Parameter	Condition	Min.	Max.	Unit
Program / erase cycles	Grade 3, Autograde 6, Grade 6	100,000		Cycles per sector
Data retention	at 55°C	20		years

Table 12. AC measurement conditions

Symbol	Parameter	Min.	Max.	Unit
C_L	Load Capacitance	30		pF
	Input Rise and Fall Times		5	ns
	Input Pulse Voltages	0.2 V_{CC} to 0.8 V_{CC}		V
	Input Timing Reference Voltages	0.3 V_{CC} to 0.7 V_{CC}		V
	Output Timing Reference Voltages	$V_{CC} / 2$		V

1. Output Hi-Z is defined as the point where data out is no longer driven.

Figure 20. AC measurement I/O waveform

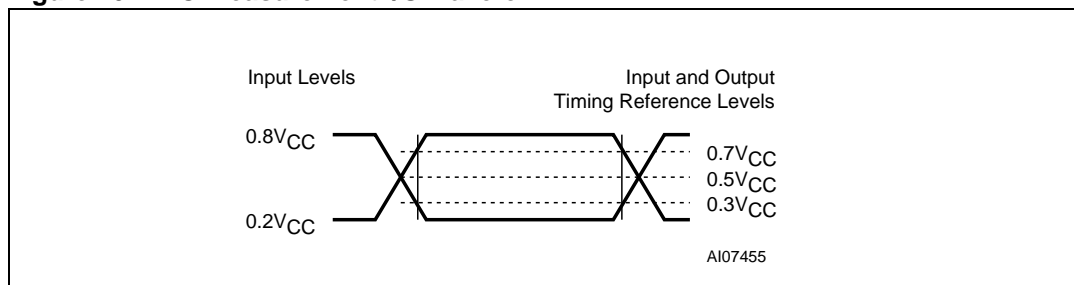

Table 13. Capacitance

Symbol	Parameter	Test condition	Min.	Max.	Unit
C_{OUT}	Output Capacitance (Q)	$V_{OUT} = 0\text{ V}$		8	pF
C_{IN}	Input Capacitance (other pins)	$V_{IN} = 0\text{ V}$		6	pF

1. Sampled only, not 100% tested, at $T_A = 25\text{ °C}$ and a frequency of 20 MHz.

Table 14. DC characteristics

Symbol	Parameter	Test condition (in addition to those in Table 10)	Min.	Max.	Unit
I_{LI}	Input Leakage Current			± 2	μA
I_{LO}	Output Leakage Current			± 2	μA
I_{CC1} Grade 6	Standby Current	$\bar{S} = V_{CC}, V_{IN} = V_{SS}$ or V_{CC}		50	μA
I_{CC1} Grade 3				100	
I_{CC2} Grade 6	Deep Power-down Current	$\bar{S} = V_{CC}, V_{IN} = V_{SS}$ or V_{CC}		10	
I_{CC2} Grade 3				50	
I_{CC3}	Operating Current (READ)	$C = 0.1V_{CC} / 0.9.V_{CC}$ at 50 MHz, Q = open		8	mA
		$C = 0.1V_{CC} / 0.9.V_{CC}$ at 20 MHz, Q = open		4	mA
I_{CC4}	Operating Current (PP)	$\bar{S} = V_{CC}$		15	mA
I_{CC5}	Operating Current (WRSR)	$\bar{S} = V_{CC}$		20	mA
I_{CC6}	Operating Current (SE)	$\bar{S} = V_{CC}$		20	mA
I_{CC7}	Operating Current (BE)	$\bar{S} = V_{CC}$		20	mA
I_{CCPP}	Operating current for Fast Program/Erase mode	$\bar{S} = V_{CC}, V_{PP} = V_{PPH}$		20	mA
V_{IL}	Input Low Voltage		-0.5	$0.3V_{CC}$	V
V_{IH}	Input High Voltage		$0.7V_{CC}$	$V_{CC}+0.2$	V
V_{OL}	Output Low Voltage	$I_{OL} = 1.6\text{ mA}$		0.4	V
V_{OH}	Output High Voltage	$I_{OH} = -100\text{ }\mu\text{A}$	$V_{CC}-0.2$		V

Table 15. DC characteristics process technology T9HX (1)

Symbol	Parameter	Test condition (in addition to those in Table 10)	Min	Max	Unit
I_{LI}	Input leakage current			± 2	μA
I_{LO}	Output leakage current			± 2	μA
I_{CC1}	Standby current	$\bar{S} = V_{CC}, V_{IN} = V_{SS} \text{ or } V_{CC}$		50	μA
I_{CC2}	Deep Power-down current	$\bar{S} = V_{CC}, V_{IN} = V_{SS} \text{ or } V_{CC}$		10	μA
I_{CC3}	Operating current (READ)	$C = 0.1V_{CC} / 0.9V_{CC}$ at 75 MHz, DQ1 = open		12	mA
		$C = 0.1V_{CC} / 0.9V_{CC}$ at 33 MHz, DQ1 = open		4	mA
I_{CC4}	Operating current (PP)	$\bar{S} = V_{CC}$		15	mA
I_{CC5}	Operating current (WRSR)	$\bar{S} = V_{CC}$		15	mA
I_{CC6}	Operating current (SE)	$\bar{S} = V_{CC}$		15	mA
V_{IL}	Input low voltage		-0.5	$0.3V_{CC}$	V
V_{IH}	Input high voltage		$0.7V_{CC}$	$V_{CC}+0.4$	V
V_{OL}	Output low voltage	$I_{OL} = 1.6 \text{ mA}$		0.4	V
V_{OH}	Output high voltage	$I_{OH} = -100 \mu A$	$V_{CC}-0.2$		V

1. Technology T9HX devices are identified by process identification digit "4" in the device marking.

Table 16. AC characteristics

Test conditions specified in Table 10 and Table 12						
Symbol	Alt.	Parameter	Min.	Typ.	Max.	Unit
f_C	f_C	Clock Frequency for the following instructions: FAST_READ, PP, SE, BE, RES, WREN, WRDI, RDID, RDSR, WRSR	D.C.		50	MHz
f_R		Clock Frequency for READ instructions	D.C.		20	MHz
$t_{CH}^{(1)}$	t_{CLH}	Clock High Time	9			ns
$t_{CL}^{(1)}$	t_{CLL}	Clock Low Time	9			ns
$t_{CLCH}^{(2)}$		Clock Rise Time ⁽³⁾ (peak to peak)	0.1			V/ns
$t_{CHCL}^{(2)}$		Clock Fall Time ⁽³⁾ (peak to peak)	0.1			V/ns
t_{SLCH}	t_{CSS}	\overline{S} Active Setup Time (relative to C)	5			ns
t_{CHSL}		\overline{S} Not Active Hold Time (relative to C)	5			ns
t_{DVCH}	t_{DSU}	Data In Setup Time	2			ns
t_{CHDX}	t_{DH}	Data In Hold Time	5			ns
t_{CHSH}		\overline{S} Active Hold Time (relative to C)	5			ns
t_{SHCH}		\overline{S} Not Active Setup Time (relative to C)	5			ns
t_{SHSL}	t_{CSH}	\overline{S} Deselect Time	100			ns
$t_{SHQZ}^{(2)}$	t_{DIS}	Output Disable Time			8	ns
t_{CLQV}	t_V	Clock Low to Output Valid			8	ns
t_{CLQX}	t_{HO}	Output Hold Time	0			ns
t_{HLCH}		\overline{HOLD} Setup Time (relative to C)	5			ns
t_{CHHH}		\overline{HOLD} Hold Time (relative to C)	5			ns
t_{HHCH}		\overline{HOLD} Setup Time (relative to C)	5			ns
t_{CHHL}		\overline{HOLD} Hold Time (relative to C)	5			ns
$t_{HHQX}^{(2)}$	t_{LZ}	\overline{HOLD} to Output Low-Z			8	ns
$t_{HLQZ}^{(2)}$	t_{HZ}	\overline{HOLD} to Output High-Z			8	ns
$t_{WHSL}^{(4)}$		Write Protect Setup Time	20			ns
$t_{SHWL}^{(4)}$		Write Protect Hold Time	100			ns
$t_{VPPHSL}^{(6)}$		Enhanced Program Supply Voltage High to Chip Select Low	200			ns
t_W		Write Status Register Cycle Time		5	15	ms
$t_{PP}^{(5)}$		Page Program Cycle Time (256 Bytes)		1.4	5	ms
		Page Program Cycle Time (n Bytes)		$0.4 + n \cdot 1/256$		
		Page Program Cycle Time ($V_{PP} = V_{PPH}$) (256 Bytes)		0.35		ms
t_{SE}		Sector Erase Cycle Time		1	3	s
		Sector Erase Cycle Time ($V_{PP} = V_{PPH}$)		0.5		s
t_{BE}		Bulk Erase Cycle Time		68	160	s
		Bulk Erase Cycle Time ($V_{PP} = V_{PPH}$)		35	160	s

- $t_{CH} + t_{CL}$ must be greater than or equal to $1/f_C(\max)$
- Value guaranteed by characterization, not 100% tested in production.
- Expressed as a slew-rate.
- Only applicable as a constraint for a WRSR instruction when SRWD is set at 1.
- When using the Page Program (PP) instruction to program consecutive Bytes, optimized timings are obtained with one sequence including all the Bytes versus several sequences of only a few Bytes. ($1 \leq n \leq 256$).
- V_{PPH} should be kept at a valid level until the program/erase operation is completed and result (success or failure) is known.

Table 17. AC characteristics, T9HX parts (page 1 of 2) ⁽¹⁾

Test conditions specified in Table 10 and Table 12						
Symbol	Alt.	Parameter	Min	Typ ⁽²⁾	Max	Unit
f_C	f_C	Clock frequency for the following instructions: FAST_READ, SE, BE, WREN, WRDI, RDID, RDSR, WRSR, PP	D.C.		75	MHz
f_R		Clock frequency for read instructions	D.C.		33	MHz
$t_{CH}^{(3)}$	t_{CLH}	Clock High time	6			ns
$t_{CL}^{(2)}$	t_{CLL}	Clock Low time	6			ns
$t_{CLCH}^{(4)}$		Clock rise time ⁽⁵⁾ (peak to peak)	0.1			V/ns
$t_{CHCL}^{(3)}$		Clock fall time ⁽⁴⁾ (peak to peak)	0.1			V/ns
t_{SLCH}	t_{CSS}	\overline{S} active setup time (relative to C)	5			ns
t_{CHSL}		\overline{S} not active hold time (relative to C)	5			ns
t_{DVCH}	t_{DSU}	Data in setup time	2			ns
t_{CHDX}	t_{DH}	Data in hold time	5			ns
t_{CHSH}		\overline{S} active hold time (relative to C)	5			ns
t_{SHCH}		\overline{S} not active setup time (relative to C)	5			ns
t_{SHSL}	t_{CSH}	\overline{S} deselect time	80			ns
$t_{SHQZ}^{(3)}$	t_{DIS}	Output disable time			8	ns
t_{CLQV}	t_V	Clock Low to Output valid under 30 pF			8	ns
		Clock Low to Output valid under 10 pF			6	ns
t_{CLQX}	t_{HO}	Output hold time	0			ns
t_{HLCH}		\overline{HOLD} setup time (relative to C)	5			ns
t_{CHHH}		\overline{HOLD} hold time (relative to C)	5			ns
t_{HHCH}		\overline{HOLD} setup time (relative to C)	5			ns
t_{CHHL}		\overline{HOLD} hold time (relative to C)	5			ns
$t_{HHQX}^{(3)}$	t_{LZ}	\overline{HOLD} to Output Low-Z			8	ns
$t_{HLQZ}^{(3)}$	t_{HZ}	\overline{HOLD} to Output High-Z			8	ns
$t_{WHSL}^{(6)}$		Write protect setup time	20			ns
$t_{SHWL}^{(5)}$		Write protect hold time	100			ns
$t_{VPPHSL}^{(7)}$		Enhanced program supply voltage High (V_{PPH}) to Chip Select Low	200			ns
$t_{RDP}^{(3)}$		\overline{S} High to standby mode			30	μ s
t_W		Write status register cycle time		1.3	15	ms
$t_{PP}^{(8)}$		Page program cycle time (256 bytes)		0.8	5	ms
		Page program cycle time (n bytes)		$\text{int}(n/8) \times 0.025^{(9)}$		

Table 17. AC characteristics, T9HX parts (page 2 of 2) ⁽¹⁾

Test conditions specified in Table 10 and Table 12						
Symbol	Alt.	Parameter	Min	Typ ⁽²⁾	Max	Unit
t _{SE}		Sector erase cycle time		0.7	3	s
t _{BE}		Bulk erase cycle time		68	160	s

1. Technology T9HX devices are identified by process identification digit "4" in the device marking.
2. Typical values given for T_A = 25° C.
3. t_{CH} + t_{CL} must be greater than or equal to 1/ f_C.
4. Value guaranteed by characterization, not 100% tested in production.
5. Expressed as a slew-rate.
6. Only applicable as a constraint for a WRSR instruction when SRWD is set to '1'.
7. V_{PPH} should be kept at a valid level until the program or erase operation has completed and its result (success or failure) is known. Avoid applying V_{PPH} to the W/VPP pin during Bulk Erase.
8. When using the page program (PP) instruction to program consecutive bytes, optimized timings are obtained with one sequence including all the bytes versus several sequences of only a few bytes (1 ≤ n ≤ 256).
9. int(A) corresponds to the upper integer part of A. For example int(12/8) = 2, int(32/8) = 4 int(15.3) = 16.

Figure 21. Serial input timing

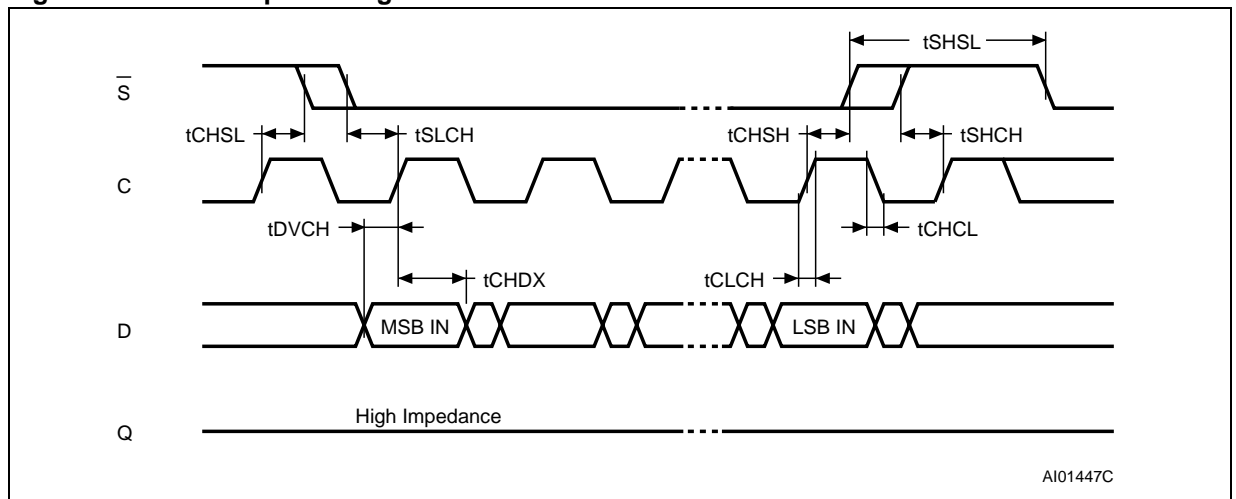

Figure 22. Write Protect setup and hold timing during WRSR when SRWD = 1

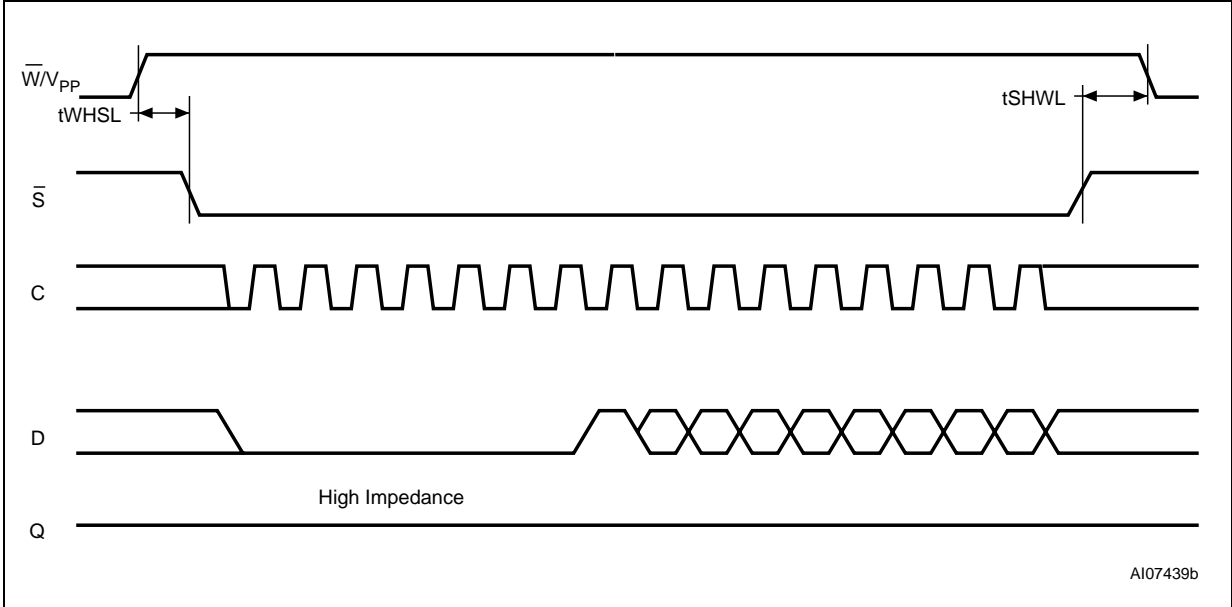

Figure 23. Hold timing

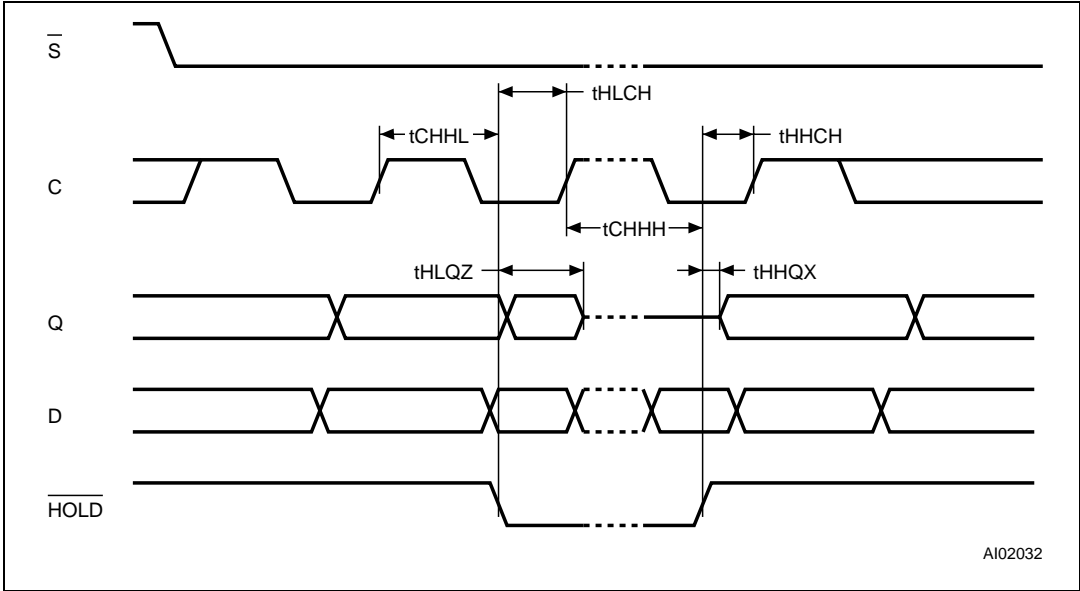

Figure 24. Output timing

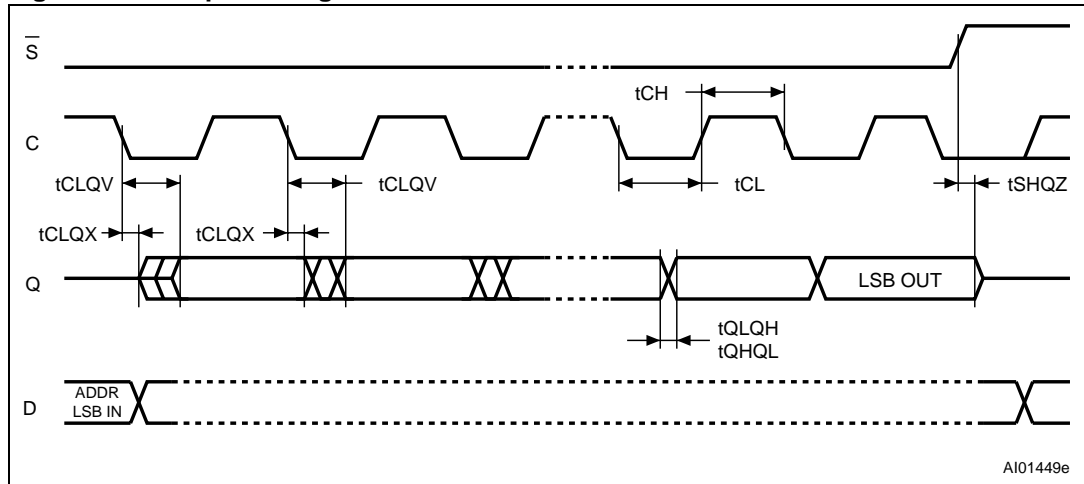
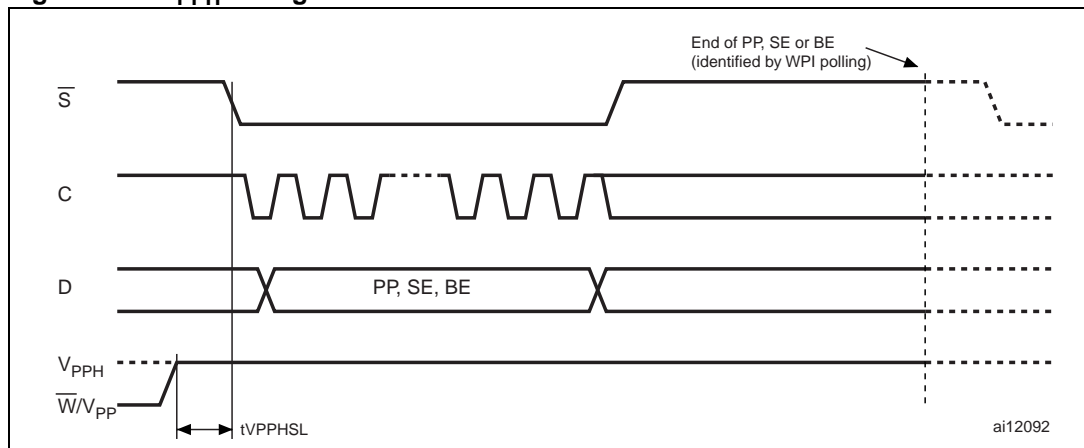
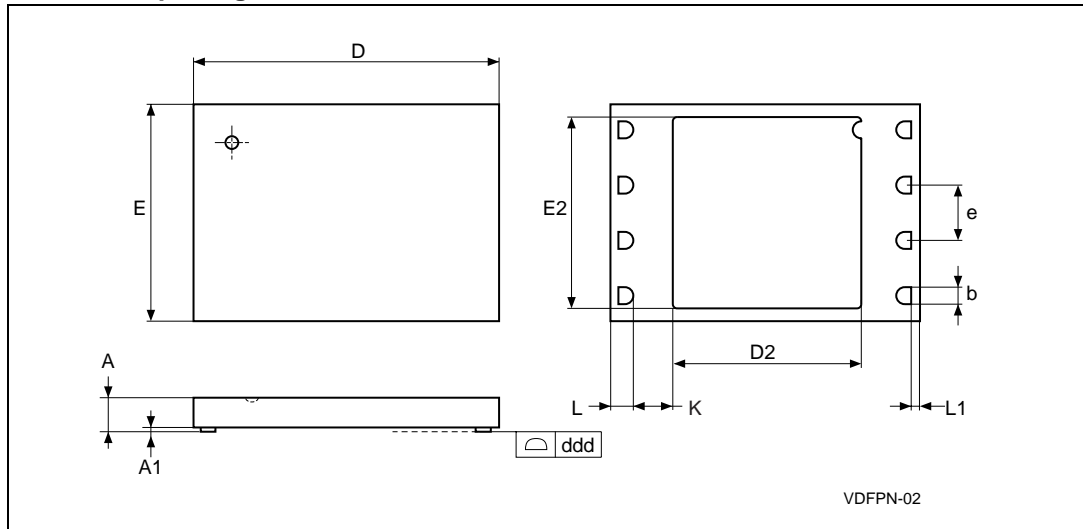

Figure 25. V_{PPH} timing



11 Package mechanical

Figure 26. VDFPN8 (MLP8) 8-lead Very thin Dual Flat Package No lead, 8 × 6 mm, package outline



1. Drawing is not to scale.
2. The circle in the top view of the package indicates the position of pin 1.

Table 18. VDFPN8 (MLP8) 8-lead Very thin Dual Flat Package No lead, 8 × 6 mm, package mechanical data

Symbol	millimeters			inches		
	Typ	Min	Max	Typ	Min	Max
A	0.85		1.00	0.0335		0.0394
A1		0.00	0.05		0.0000	0.0020
b	0.40	0.35	0.48	0.0157	0.0138	0.0189
D	8.00			0.3150		
D2	5.16		(1)	0.2031		
ddd			0.05			0.0020
E	6.00			0.2362		
E2	4.80			0.1890		
e	1.27	–	–	0.0500	–	–
K		0.82			0.0323	
L	0.50	0.45	0.60	0.0197	0.0177	0.0236
L1			0.15			0.0059
N	8			8		

1. D2 Max must not exceed (D – K – 2 × L).

Figure 27. SO16 wide – 16 lead Plastic Small Outline, 300 mils body width

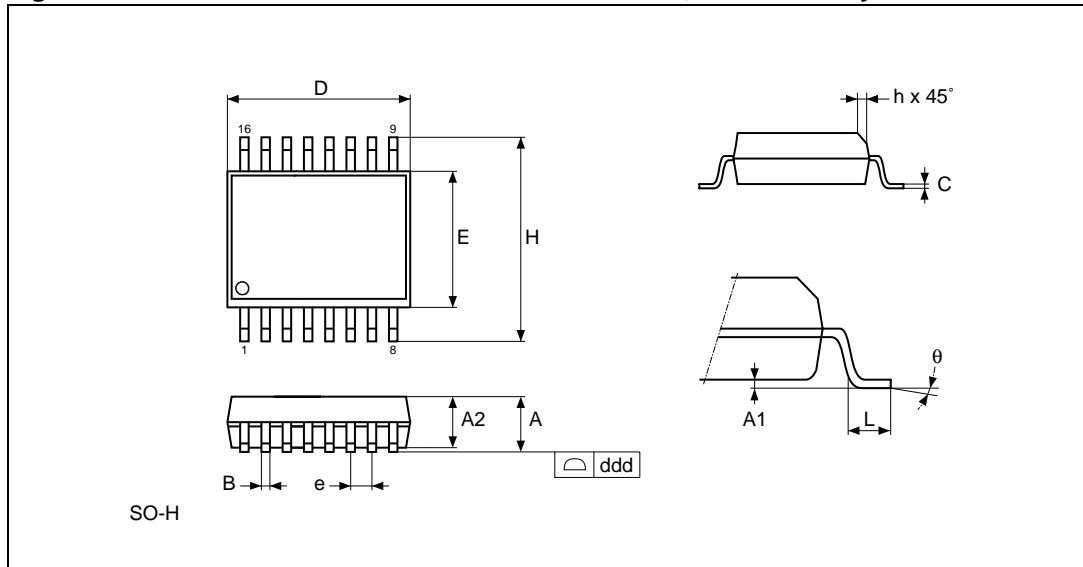

1. Drawing is not to scale.

Table 19. SO16 wide – 16 lead Plastic Small Outline, 300 mils body width, package mechanical data

Symbol	millimeters			inches		
	Typ	Min	Max	Typ	Min	Max
A		2.35	2.65		0.093	0.104
A1		0.10	0.30		0.004	0.012
B		0.33	0.51		0.013	0.020
C		0.23	0.32		0.009	0.013
D		10.10	10.50		0.398	0.413
E		7.40	7.60		0.291	0.299
e	1.27	–	–	0.050	–	–
H		10.00	10.65		0.394	0.419
h		0.25	0.75		0.010	0.030
L		0.40	1.27		0.016	0.050
θ		0°	8°		0°	8°
ddd			0.10			0.004

12 Ordering Information, Standard Parts

Table 20. Ordering information scheme

Example:	M25P64	-	V	MF	6	T	P	B	A
Device Type									
M25P = Serial Flash memory for Code Storage									
Device Function									
64 = 64 Mbit (8M x 8)									
Security Features ⁽¹⁾									
- = no extra security									
S- = CFD programmed with UID									
Operating Voltage									
V = V _{CC} = 2.7 V to 3.6 V									
Package									
MF = SO16 (300 mil width)									
ME = VDFPN8 8 x 6 mm (MLP8) ⁽²⁾									
Device Grade									
6 = Industrial temperature range, -40 to 85 °C.									
Device tested with standard test flow.									
3 = Automotive temperature range, -40 to 125 °C. ⁽¹⁾									
Device tested with high reliability certified flow. ⁽³⁾									
Option									
blank = Standard Packing									
T = Tape and Reel Packing									
Plating Technology									
P or G = RoHS compliant									
Lithography⁽⁴⁾									
B = 110nm, Fab.2 Diffusion Plant									
Automotive Grade									
A = Automotive, -40 to 85 °C.									
Device tested with high reliability certified flow ⁽⁵⁾									
blank = standard -40 to 85 °C device.									

- Secure options are available upon customer request.
- Please contact your nearest Numonyx Sales Office for Automotive Package options availability.
- Numonyx strongly recommends the use of the Automotive Grade devices (AutoGrade 6 and Grade 3) for use in an automotive environment. The high reliability certified flow (HRCF) is described in the quality note QNEE9801. Please ask your nearest Numonyx sales office for a copy.
- The lithography digit is present only in the automotive parts ordering scheme.
- Numonyx strongly recommends the use of the Automotive Grade devices for use in an automotive environment. The High Reliability Certified Flow (HRCF) is described in the quality note NNEE9801. Please ask your nearest Numonyx sales office for a copy.

For a list of available options (speed, package, etc.) or for further information on any aspect of this device, please contact your nearest Numonyx Sales Office.

The category of second-Level Interconnect is marked on the package and on the inner box label, in compliance with JEDEC Standard JESD97. The maximum ratings related to soldering conditions are also marked on the inner box label.

13 Ordering Information, Automotive Parts

Table 21. Ordering information scheme

Example:	M25P64	-	V	MF	6	T	P	B	A
Device Type									
M25P = Serial Flash memory for Code Storage									
Device Function									
64 = 64 Mbit (8 Mbit x 8)									
Security Features									
- = no extra security									
Operating Voltage									
V = V _{CC} = 2.7 V to 3.6 V									
Package									
MF = SO16 (300 mil width)									
Device Grade									
6 = Industrial temperature range, -40 to 85 °C. Device tested with high reliability certified flow.									
3 = Automotive temperature range, -40 to 125 °C. Device tested with high reliability certified flow.									
Option									
blank = Standard Packing T = Tape and Reel Packing									
Plating Technology									
P or G = RoHS compliant									
Lithography									
B = 110nm, Fab.2 Diffusion Plant									
Automotive Grade									
blank = Automotive -40 to 125 °C part A = Automotive -40 °C to 85 °C part (used ONLY in conjunction with Device Grade 6 to distinguish the Auto Tested Parts from the non Auto Tested parts).									

Note: Numonyx strongly recommends the use of the Automotive Grade devices (Auto Grade 6 and 3) in an automotive environment. The high reliability certified flow (HRCF) is described in the quality note QNEE9801. Please ask your Numonyx sales office for a copy.

14 Revision history

Table 22. Document revision history

Date	Revision	Changes
28-Apr-2003	0.1	Target Specification Document written in brief form
15-May-2003	0.2	Target Specification Document written in full
20-Jun-2003	0.3	8x6 MLP8 and SO16(300 mil) packages added
18-Jul-2003	0.4	t_{PP} , t_{SE} and t_{BE} revised
02-Sep-2003	0.5	Voltage supply range changed
19-Sep-2003	0.6	Table of contents, warning about exposed paddle on MLP8, and Pb-free options added
17-Dec-2003	0.7	Value of t_{VSL} (min) V_{WI} , t_{PP} (typ) and t_{BE} (typ) changed. MLP8 package removed.
15-Nov-2004	1.0	Document status promoted from Target Specification to Preliminary Data. 8x6 MLP8 package added. Minor wording changes.
24-Feb-2005	2.0	Deep Power-Down mode removed from datasheet (Figure 18: Read Electronic Signature (RES) instruction sequence and data-out sequence modified and t_{RES1} and t_{RES2} removed from Table 16: AC characteristics). SO16 Wide package specifications updated. End timing line of t_{SHQZ} modified in Figure 24: Output timing . Figures moved below the corresponding instructions in the Instructions section.
23-Dec-2005	3.0	Updated Page Program (PP) instructions in Page Programming , Page Program (PP) and Table 16: AC characteristics . Fast Program/Erase mode added and Power-up specified for Fast Program/Erase mode in Power-up and Power-down section. \bar{W} pin changed to \bar{W}/V_{PP} . (see Write Protect/Enhanced Program supply voltage (W/VPP) description). Note 2 inserted below Figure 26 Blank option removed under Plating Technology . t_{VPPHSL} added to Table 16: AC characteristics and Figure 25: VPPH timing inserted. All packages are RoHS compliant. Document status promoted from Preliminary Data to full Datasheet status.
16-Feb-2006	4.0	VDFPN8 (MLP8) package specifications updated (see Section 11: Package mechanical).
07-Sep-2006	5	Figure 4: Bus master and memory devices on the SPI bus modified. I_{CC1} maximum value updated in Table 14: DC characteristics .
19-Jan-2007	6	Hardware Write Protection feature added to Features on page 1 . VCC supply voltage and VSS ground descriptions added. Figure 4: Bus master and memory devices on the SPI bus updated and explanatory paragraph added. At Power-up The Write In Progress (WIP) bit is reset . V_{IO} max modified and T_{LEAD} added in Table 9: Absolute maximum ratings . Small text changes. Note 1 added to Table 18: VDFPN8 (MLP8) 8-lead Very thin Dual Flat Package No lead, 8 x 6 mm, package mechanical data .

Table 22. Document revision history

Date	Revision	Changes
10-Dec-2007	7	Applied Numonyx branding.
30-Oct-2008	8	To provide support for the Automotive market, added the following: – Automotive bullet to cover page; – Grade 3 and grade 6 information to Table 10.: Operating conditions ; – Table 11.: Data Retention and Endurance – Automotive information to Table 20.: Ordering information scheme .
22-May-2009	9	Added a lithography note to Table 20.: Ordering information scheme ; Added information supporting 75 MHz.
2-Oct-2009	10	Introduced CFD programmed secure version.
2-Nov-2009	11	Updated ordering information.
8-March-2010	12	Created lcc1, Grade 6 and Grade 3 and lcc2, Grade 6 and Grade 3 in Table 14.: DC characteristics .

Please Read Carefully:

INFORMATION IN THIS DOCUMENT IS PROVIDED IN CONNECTION WITH NUMONYX™ PRODUCTS. NO LICENSE, EXPRESS OR IMPLIED, BY ESTOPPEL OR OTHERWISE, TO ANY INTELLECTUAL PROPERTY RIGHTS IS GRANTED BY THIS DOCUMENT. EXCEPT AS PROVIDED IN NUMONYX'S TERMS AND CONDITIONS OF SALE FOR SUCH PRODUCTS, NUMONYX ASSUMES NO LIABILITY WHATSOEVER, AND NUMONYX DISCLAIMS ANY EXPRESS OR IMPLIED WARRANTY, RELATING TO SALE AND/OR USE OF NUMONYX PRODUCTS INCLUDING LIABILITY OR WARRANTIES RELATING TO FITNESS FOR A PARTICULAR PURPOSE, MERCHANTABILITY, OR INFRINGEMENT OF ANY PATENT, COPYRIGHT OR OTHER INTELLECTUAL PROPERTY RIGHT.

Numonyx products are not intended for use in medical, life saving, life sustaining, critical control or safety systems, or in nuclear facility applications.

Numonyx may make changes to specifications and product descriptions at any time, without notice.

Numonyx, B.V. may have patents or pending patent applications, trademarks, copyrights, or other intellectual property rights that relate to the presented subject matter. The furnishing of documents and other materials and information does not provide any license, express or implied, by estoppel or otherwise, to any such patents, trademarks, copyrights, or other intellectual property rights.

Designers must not rely on the absence or characteristics of any features or instructions marked "reserved" or "undefined." Numonyx reserves these for future definition and shall have no responsibility whatsoever for conflicts or incompatibilities arising from future changes to them.

Contact your local Numonyx sales office or your distributor to obtain the latest specifications and before placing your product order.

Copies of documents which have an order number and are referenced in this document, or other Numonyx literature may be obtained by visiting Numonyx's website at <http://www.numonyx.com>.

Numonyx StrataFlash is a trademark or registered trademark of Numonyx or its subsidiaries in the United States and other countries.

*Other names and brands may be claimed as the property of others.

Copyright © 2010, Numonyx, B.V., All Rights Reserved.

Looking for pricing, stock, or lifecycle information?

Click below to explore more details on WIN SOURCE:

- ⊖ [View M25P64-VMF3PB on WIN SOURCE](#)
- ⊖ [Micron Technology Inc. Information](#)

Optimize Your Supply Chain with WIN SOURCE Solutions

- ✓ Global Sourcing Solution
- ✓ Obsolete Management
- ✓ Cost Control Management
- ✓ Shortage Management
- ✓ Alternative Solution
- ✓ Excess Inventory Management