

5ch System Motor Driver

BD8203EFV

General Description

BD8203EFV is a 5ch system motor driver for CD/DVD. A linear BTL mode can be adopted for all 5ch to reduce noise. It has a Built-in 5V regulator, a changeable regulator, and a general-purpose operational amplifier. Designed best for car audio systems.

Features

- Linear BTL method is implemented for the actuator driver and the DC motor driver to reduce noise.
- Loading driver 1ch
- Built-in regulator 2ch (1ch output changeable)
- MUTE function and Standby function
- Built-in general-purpose operational amplifier 1ch
- Built-in internal operational amplifier for the voltage detection between driver outputs and for VC standard

Applications

Car Audio

Key Specifications

- Power Supply Voltage Range: Driver Part Pre Steps and Regulator1 7.5V to 14V
Driver Part Power Steps 4.5V to V_{PREVCC} V
Power Steps of Two Regulators 4.5V to V_{PREVCC} V
- Standby-on Current: 1mA(Max)
- Operating Temperature Range: -40°C to +85°C

Package

W(Typ) x D(Typ) x H(Max)

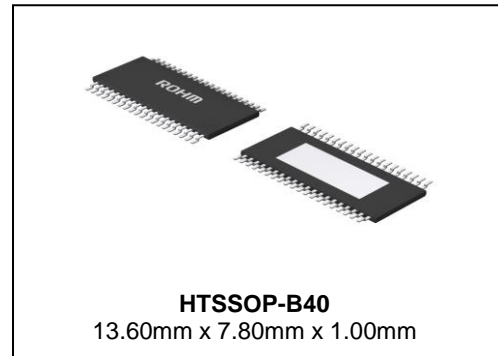

Typical Application Circuit

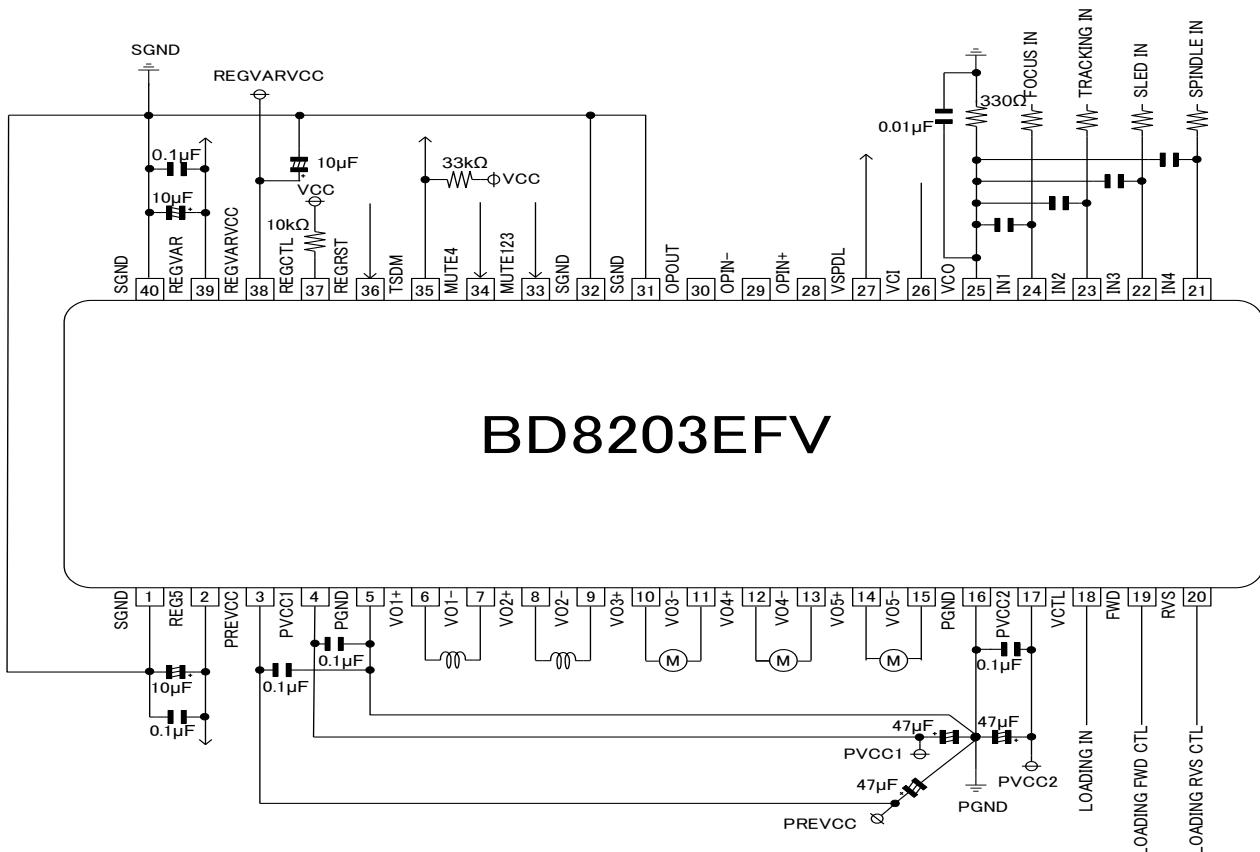

○Product structure : Silicon monolithic integrated circuit ○This product has no designed protection against radioactive rays

Block Diagram and Pin Configuration

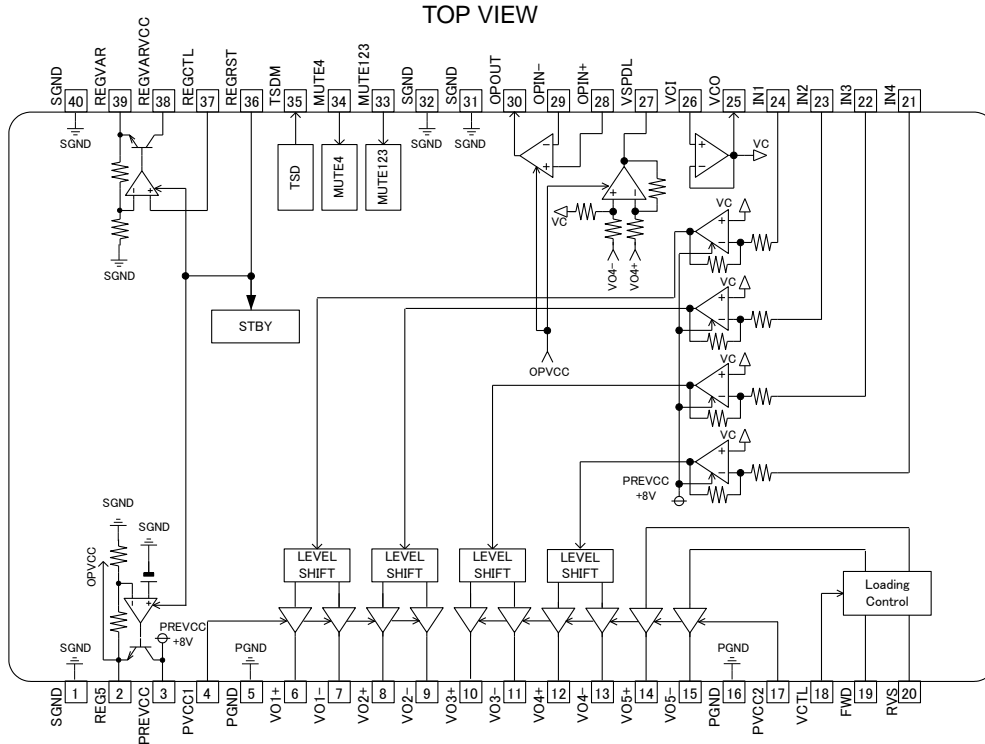

Pin Description

No.	Symbol	Description	No.	Symbol	Description
1	SGND	Signal GND	21	IN4	CH4(SPDL)input
2	REG5	REG5V Output	22	IN3	CH3(SLD)input
3	PREVCC	PRE part, REG circuit, power supply terminal(+8V)	23	IN2	CH2(TRK)input
4	PVCC1	Power supply 1	24	IN1	CH1(FCS) input
5	PGND	Power GND	25	VCO	Standard voltage (VC) output
6	VO1+	CH1(FCS) Positive output	26	VCI	Standard voltage (VC) input
7	VO1-	CH1(FCS) Negative output	27	VSPDL	Voltage detection value output between VO4 outputs
8	VO2+	CH2(TRK) Positive output	28	OPIN+	General purpose Op Amp non-reversing input
9	VO2-	CH2(TRK) Negative output	29	OPIN-	General purpose Op Amp reversing input
10	VO3+	CH3(SLD) Positive output	30	OPOUT	General purpose Op Amp output
11	VO3-	CH3(SLD) Negative output	31	SGND	Signal GND
12	VO4+	CH4(SPDL) Positive output	32	SGND	Signal GND
13	VO4-	CH4(SPDL) Negative output	33	MUTE123	MUTE CH1,2,3
14	VO5+	CH5(Load) Positive output	34	MUTE4	MUTE CH4(SPDL)
15	VO5-	CH5(Load) Negative output	35	TSDM	Thermal shutdown flag output
16	PGND	Power GND	36	REGRST	REG Reset input
17	PVCC2	Power supply 2	37	REGCTL	REGVAR Output changeability input terminal
18	VCTL	CH5(Load) Voltage control input	38	REGVARVCC	REGVAR Tr power supply terminal
19	FWD	CH5(Load) FWD input	39	REGVAR	REGVAR output
20	RVS	CH5(Load) RVS input	40	SGND	Signal GND

Absolute Maximum Ratings (Ta=25°C)

Parameter	Symbol	Limit	Unit
Power Supply Voltage	V _{PREVCC} , V _{PVCC1} , V _{PVCC2} , V _{REGVARVCC}	15	V
Input Terminal Voltage1	V _{IN1} (Note 1)	V _{PREVCC}	V
Input Terminal Voltage2	V _{IN2} (Note 2)	V _{REG5}	V
Output Terminal Voltage	V _{OUT} (Note 3)	V _{REG5}	V
Operating Temperature Range	T _{opr}	-40 to +85	°C
Storage Temperature	T _{stg}	-55 to +150	°C
Junction Temperature	T _{jmax}	150	°C
Power Dissipation	P _d (Note 4)	4.7	W

(Note 1) Input terminal 1 : REGRST

(Note 2) Input terminal 2 : REGCTL, MUTE123, MUTE4, VCI, RVS, FWD, IN1, IN2, IN3, IN4, OPIN+, OPIN-, VCTL

(Note 3) Output terminal : VCO, TSDM, VSPDL

(Note 4) Ta =25°C, Standard board mounting

(70mm x 70mm x 1.6mm, 4 glass epoxy layer substrate, 70mm x 70mm of the back copper foil area)

Reduce power by 34.6mW for each degree above 25°C.

Caution: Operating the IC over the absolute maximum ratings may damage the IC. The damage can either be a short circuit between pins or an open circuit between pins and the internal circuitry. Therefore, it is important to consider circuit protection measures, such as adding a fuse, in case the IC is operated over the absolute maximum ratings.

Recommended Operating Conditions (Ta=-40°C to +85°C)

(Set the power supply voltage taking allowable dissipation into considerations.)

Parameter	Symbol	Min	Typ	Max	Unit
Driver Part Pre Steps and Regulator 1 Power-Supply Voltage	V _{PREVCC}	7.5	8	14	V
Driver Part Power Steps Power-Supply Voltage	V _{PVCC1} , V _{PVCC2}	4.5	8	V _{PREVCC}	V
Power Steps of Two Regulators Power-Supply Voltage	V _{REGVARVCC}	4.5	5	V _{PREVCC}	V

Electrical Characteristics(Unless otherwise specified, V_{PREVCC}=V_{PVCC1}=V_{PVCC2}=8V, V_{REGVARVCC}=5V, V_{VCO}=1.65V, Ta=25°C)

Parameter		Symbol	MIN	TYP	MAX	Unit	Conditions
Circuit Current	Quiescent Current	I _Q	-	37	55	mA	MUTE123=MUTE4=H, FWD=RVS=L
	Standby-on Current	I _{STBY}	-	-	1	mA	Standby mode(REGRST=L)
BTL Driver	Input Offset Voltage	V _{IOBTL}	-5	0	+5	mV	
	Output Offset Voltage	V _{OFBTL}	-75	-	+75	mV	
	Output Saturation Voltage (Vertical Harmony)	V _{OSATBTL}	-	1.5	2.3	V	I _L =500mA
	Input Output Gain	G _{VBTL}	16.8	18	19.2	dB	
	Input Impedance	R _{ZINBTL}	20	40	80	kΩ	
	Slew Rate	V _{SLBTL}	1.0	-	-	V/μs	
General-purpose Operational Amplifier	Input Offset Voltage	V _{IOOP1}	-10	-	+10	mV	
	Input Bias Voltage	I _{BOP1}	-300	-	-	nA	
	H Level Output Voltage	V _{OHOOP1}	4	-	-	V	
	L Level Output Voltage	V _{LOOP1}	-	-	0.2	V	
	Output Sink Current Ability	I _{SINKOP1}	2	-	-	mA	
	Output Source Current Ability	I _{SOUOP1}	2	-	-	mA	
	Range of Same Phase Input	V _{ICMOP1}	0	-	3.8	V	V _{REG5} =5.0V
	Slew Rate	V _{SLOP1}	0.5	-	-	V/μs	

Electrical Characteristics – continued

(Unless otherwise specified, $V_{PREVCC}=V_{PVCC1}=V_{PVCC2}=8V$, $V_{REGVARVCC}=5V$, $V_{VCO}=1.65V$, $T_a=25^\circ C$)

	Parameter	Symbol	MIN	TYP	MAX	Unit	Conditions
Operational Amplifier for the Voltage Detection between Driver Outputs	Output Offset Voltage	V_{OOOP2}	-50	-	+50	mV	$V_{VO4+} = V_{VO4} = 3.4V$
	H Level Output Voltage	V_{OHOP2}	4	-	-	V	
	L Level Output Voltage	V_{OLOP2}	-	-	0.2	V	
	Output Sink Current Ability	$I_{SINKOP2}$	2	-	-	mA	
	Output Source Current Ability	I_{SOUOP2}	2	-	-	mA	
	Range of Same Phase Input	$V_{VICMOP2}$	0		6.8	V	$V_{REG5}=5.0V$
	Input Output Gain	G_{VOP2}	-6.2	-5	-3.8	dB	
	Slew Rate	V_{SLOP2}	0.5	-	-	V/ μs	
Internal Operational Amplifier for VC Standard	Output Offset Voltage	V_{OOOP3}	-10	-	+10	mV	
	Input Bias Voltage	I_{BOP3}	-300	-	-	nA	
	H level Output Voltage	V_{OHOP3}	3.5	-	-	V	
	L level Output Voltage	V_{OLOP3}	-	-	0.2	V	
	Output Sink Current Ability	$I_{SINKOP3}$	0.5	-	-	mA	
	Output Source Current Ability	I_{SOUOP3}	10	-	-	mA	
	Range of Same Phase Input	$V_{VICMOP3}$	1.1	-	3.5	V	$V_{REG5}=5.0V$ BTL range of operation
Loading Driver	Input Terminal Inflow Current	I_{INLD}	-	27	55	μA	$V_{FWD}, V_{RVS}=3.3V$
	VCTL Terminal Inflow Current	I_{INVCTL}	-1	-	-	μA	$V_{VCTL}=2V$
	Output Offset Voltage	V_{OFLD}	-50	0	+50	mV	
	Output Saturation Voltage H	V_{OHLD}	-	1.1	1.4	V	$I_L=500mA$
	Output Saturation Voltage L	V_{OLLD}	-	0.45	0.8	V	$I_L=500mA$
	Input Output Gain	G_{VLD}	7.5	9.0	10.5	dB	$V_{VCTL}=1V$
Regulator 1	REG5 Terminal Output Voltage	V_{OREG5}	4.75	5.0	5.25	V	$I_L=100mA$
	REG5 Terminal Output Current Ability	I_{REG5_I}	100	-	-	mA	
	Load Change Regulation	V_{REG5_LOAD}	-80	-	-	mV	$I_L=0mA$ to 100mA
	Input Change Regulation	V_{REG5_LINE}	-20	-	+30	mV	$V_{PREVCC}=7.5V$ to 9V, $I_L=100mA$
Regulator 2 (Output Changeability)	Range of REGVAR Output Voltage Setting	$V_{REGVARR}$	0.5	-	4.1	V	$I_L=100mA$
	REGVAR Terminal Output Current Ability	I_{REGVAR_I}	100	-	-	mA	
	REGVAR Terminal Output Voltage	V_{REGVAR}	3.4	3.6	3.8	V	$I_L=100mA, V_{REGCTL}=3.3V$
	Input Output Gain	G_{V2}	-	1.09	-	V/V	
	Load Change Regulation	V_{REGVAR_LOAD}	-80	-	-	mV	$I_L=0mA$ to 100mA
	Input Change Regulation	V_{REGVAR_LINE}	-20	-	+30	mV	$V_{REGCTL}=3.3V, V_{REGVARVCC}=4.5V$ to 5.5V, $I_L=100mA$
	Range of REGVARVCC Voltage	V_{REGVAR_ON}	$V_{REGVAR}+0.9V$	-	V_{PREVCC}	V	
	REGCTL Terminal Input Current	I_{REGCTL_I}	-1	-	-	μA	$V_{REGCTL}=3.3V$
Function	Input Voltage of Input Terminal H	V_{IHFUN}	2.0	-	V_{PREVCC}	V	MUTE123,MUTE4,RVS,FWD
	Input Voltage of Input Terminal L	V_{ILFUN}	-	-	0.8	V	MUTE123,MUTE4,RVS,FWD
	TSDM Terminal L Output Voltage	V_{OL_TSDM}	-	-	0.4	V	$R_{TSDM}=33k\Omega$ Pull-up3.3V
	VCO Drop Mute Voltage	V_{MVCO}	0.4	0.7	1	V	
	PREVCC Drop Mute Voltage	$V_{MPREVCC}$	3.4	3.8	4.2	V	
	REGRST Terminal Reset ON Voltage	V_{RESON1}	-	-	0.8	V	Turning OFF of regulator 1 and regulator 2
	REGRST Terminal Reset OFF Voltage	V_{RESOFF}	2.0	-	V_{PREVCC}	V	Turning ON of regulator 1 and regulator 2

Application Information

1. Standard Example Application Circuit

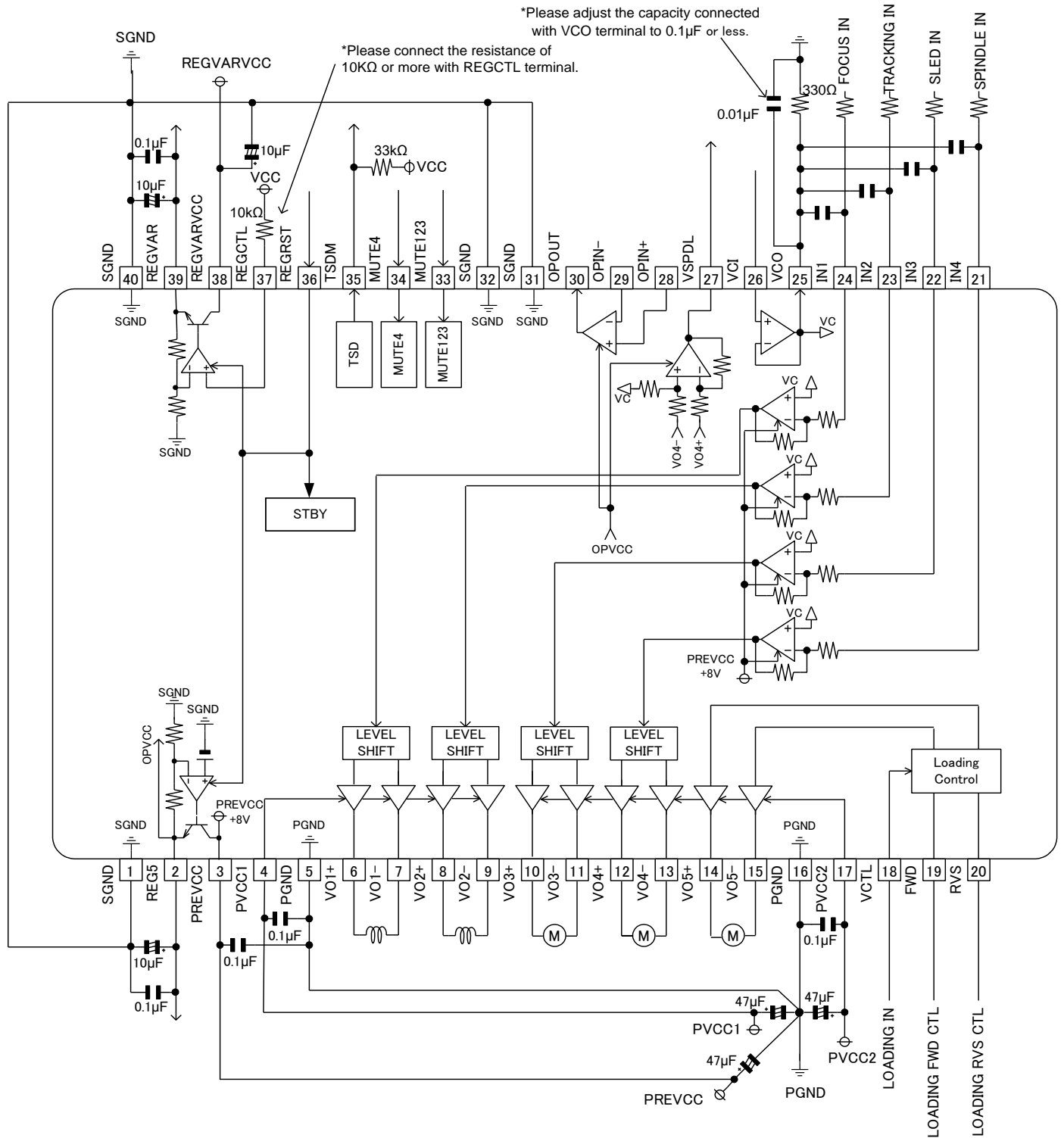

2. Functional Description

Table for operation (V_{PREVCC}=V_{PVCC1}=V_{PVCC2}=8V, V_{REGVARCC}=5V, V_{VCO}=1.65V)

Input					Output					
REGRST	MUTE123	MUTE4	FWD	RVS	REG5	REGVAR	Operational amplifier	VO1 to VO3	VO4	VO5
Low	-	-	-	-	STANDBY	STANDBY	STANDBY	STANDBY	STANDBY	STANDBY
High	Low	Low	-	-	ON	ON	ON	OFF	OFF	/
High	High	Low	-	-	ON	ON	ON	ON	OFF	
High	Low	High	-	-	ON	ON	ON	OFF	ON	
High	High	High	-	-	ON	ON	ON	ON	ON	
High	-	-	Low	Low	ON	ON	ON	/		OFF
High	-	-	High	Low	ON	ON	ON		Forward	
High	-	-	Low	High	ON	ON	ON		Reverse	
High	-	-	High	High	ON	ON	ON		Brake	

(1) BTL Driver Control

BTL driver's ON/OFF can control with MUTE123 and MUTE4 terminal.

Input			Output mode	VO1(FCS), VO2(TRK), VO3(SLD)	VO4(SPDL)
REGRST	MUTE123	MUTE4			
Low	-	-	STANDBY	Hi-Z	Hi-Z
High	Low	Low	ALL OFF	Hi-Z(M) (Note 1)	Hi-Z(M) (Note 1)
High	High	Low	FCS, TRK, SLD,	ON	Hi-Z(M) (Note 1)
High	Low	High	SPDL ON	Hi-Z(M) (Note 1)	ON
High	High	High	ALL ON	ON	ON

(Note 1) V_{VO1+} = V_{VO1-} = V_{PVCC1}/2 [V] (Typ), V_{VO2+} = V_{VO2-} = V_{PVCC1}/2 [V] (Typ)
 V_{VO3+} = V_{VO3-} = (V_{PVCC2}-0.7)/2 [V] (Typ),
 V_{VO4+} = V_{VO4-} = [(V_{PVCC2}-0.7)/2] x 15.6 + V_{VCO} x 20 / (15.6 + 20) [V] (Typ) at Hi-Z(M).
 (Example) V_{VO4+} = V_{VO4-} ≈ 2.53 [V] (Typ) at V_{PVCC2}=8[V], V_{VCO}=1.65[V]

(2) Loading Driver

Only VCTL, FWD, and RVS terminal individually controls the load.
 (This is not controlled by turning ON/OFF the MUTE123 and MUTE4 terminal)
 It operates according to the truth table below.

Input				Output mode	Voltage between outputs	VO5+(Pin14)	VO5-(Pin15)
REGRST	VCTL(Pin18)	FWD(Pin19)	RVS(Pin20)				
Low	-	-	-	STANDBY	0	Hi-Z	Hi-Z
High	(Note 2)	L	L	OFF	0	Hi-Z(M)(Note 3)	Hi-Z(M)(Note 3)
High	(Note 2)	H	L	Forward	G _{VLD} x V _{CTL}	H	L
High	(Note 2)	L	H	Reverse	G _{VLD} x V _{CTL}	L	H
High	(Note 2)	H	H	Brake	0	M (Note 4)	M (Note 4)

(Note 2) VCTL (Pin18) is an arbitrary value of 0- REG5 (= 5.0[V] (Typ)).
 (Note 3) V_{VO5+} = V_{VO5-} = (V_{PVCC2}-0.7)/2[V] (Typ) at Hi-Z(M).
 (Note 4) V_{VO5+} = V_{VO5-} = (V_{PVCC2}-0.7)/2[V] (Typ) at M.

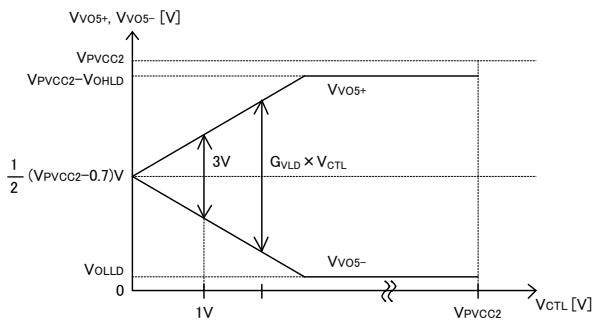

When Forward mode is set

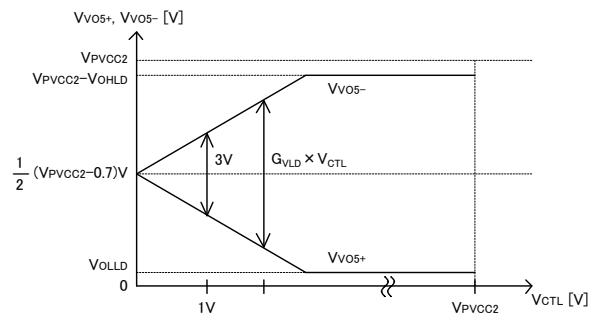

When Reverse mode is set

(3) 5V Regulator 1

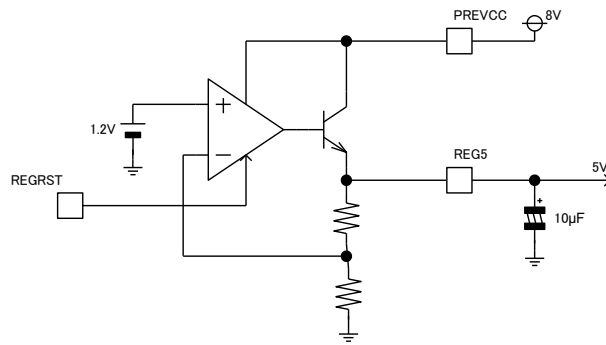

(a) Regulator 1 Control
ON/OFF of regulator 1 can be controlled by REGRST terminal.

REGRST	Regulator 1
Low	OFF
High	ON

(b) V_{CC} - V_{OUT} Characteristic

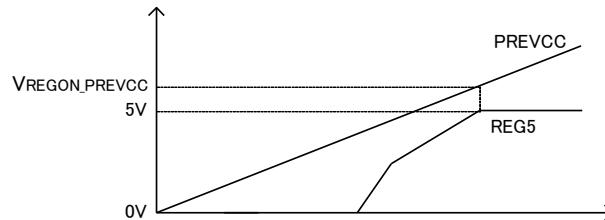

(c) Timing Chart

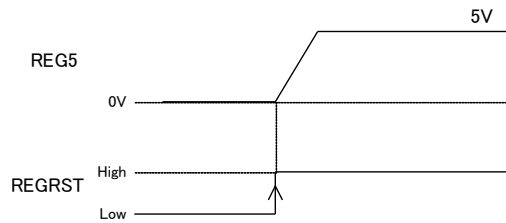

(4) 3.6V Changeable Regulator 2

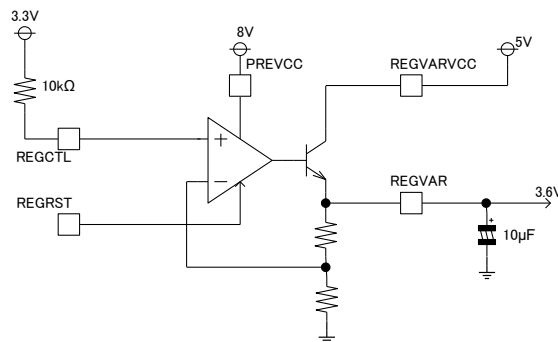

(a) Regulator 2 Controls
ON/OFF of regulator 2 can be controlled by REGRST terminal.

REGRST	Regulator 2
Low	OFF
High	ON

(b) $V_{CC} - V_{OUT}$ Characteristics

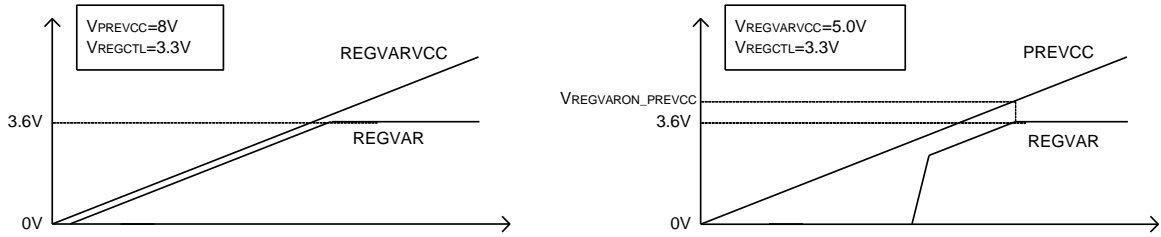

(c) $V_{REGCTL} - V_{OUT}$ Characteristic

REGVAR can be set through REGCTL terminal.
 The range of REGVAR of the output voltage setting is 0.5-4.1V (At $V_{REGVARVCC}=5V$ (Typ)).

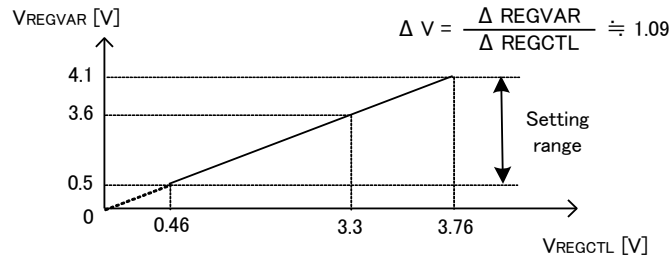

(d) Timing Chart

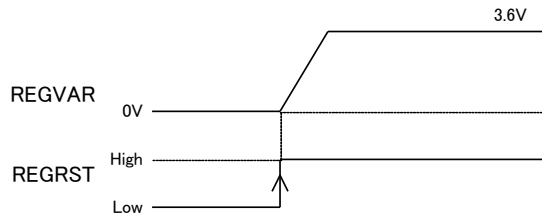

(5) OPAMP for the Voltage Detection between Driver Outputs

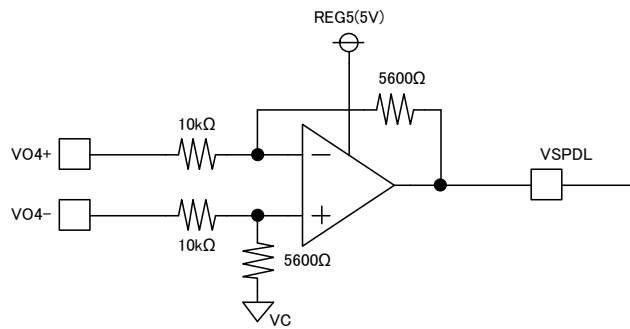

The voltage difference between $VO4+$, $VO4-$ of the BTL driver for $VSPDL$ is measured and outputted to $VSPDL$ terminal.

$$V_{VSPDL} = \frac{5600}{10k} (V_{VO4-} - V_{VO4+}) + V_{VC}$$

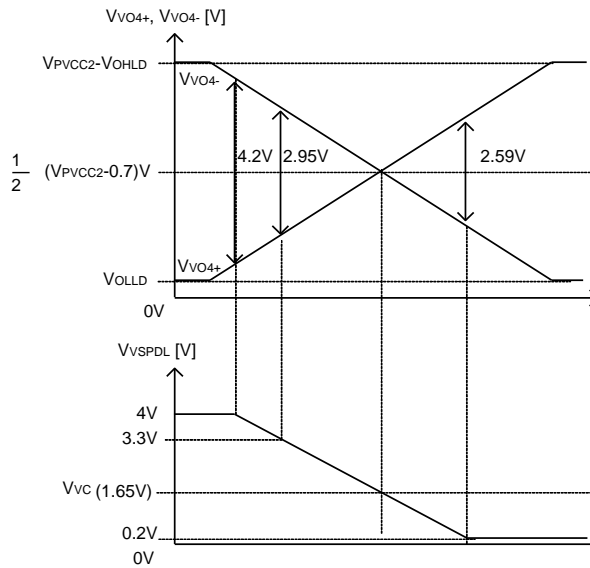

(6) Thermal Shutdown Flag Output Function
 TSDM = Hi-Z (normal operation)

When thermal shutdown is activated, TSDM terminal becomes Low, all driver outputs (VO1-VO5) and regulator outputs (REG5, REGVAR) are turned OFF (output Hi-Z).

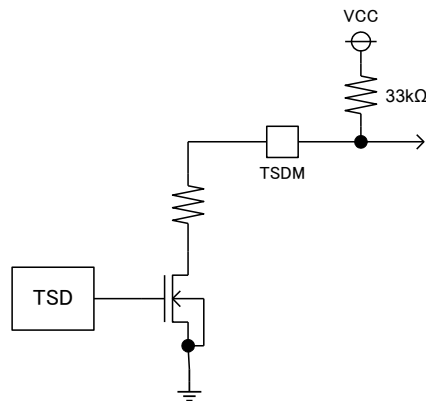

Thermal shutdown	TSDM
OFF	Hi-Z
ON	Low

(7) Power Supply Drop Mute and VC Drop Mute Function

Power supply drop mute functions at $V_{PREVCC} < V_{MPREVCC}$ (3.8V Typ). At this condition all driver outputs (VO1-VO5) are turned OFF (output Hi-Z).

VC drop mute functions at $V_{VCO} < V_{MVCO}$ (0.7V Typ). At this condition driver outputs (VO1-VO4) also are turned OFF (output Hi-Z).

Mute function list (REGRST=MUTE123=MUTE4=FWD=High at the mode state of turning ON)

Thermal shutdown	PREVCC	VCO	REG5,REGVAR	VO1 to VO4	VO5
OFF	$> V_{MPREVCC}$	$> V_{MVCO}$	ON	ON	ON
ON	-	-	OFF	OFF	OFF
OFF	$< V_{MPREVCC}$	-	ON	OFF	OFF
OFF	$> V_{MPREVCC}$	$< V_{MVCO}$	ON	OFF	ON

(8) Start-up Sequence Regulations

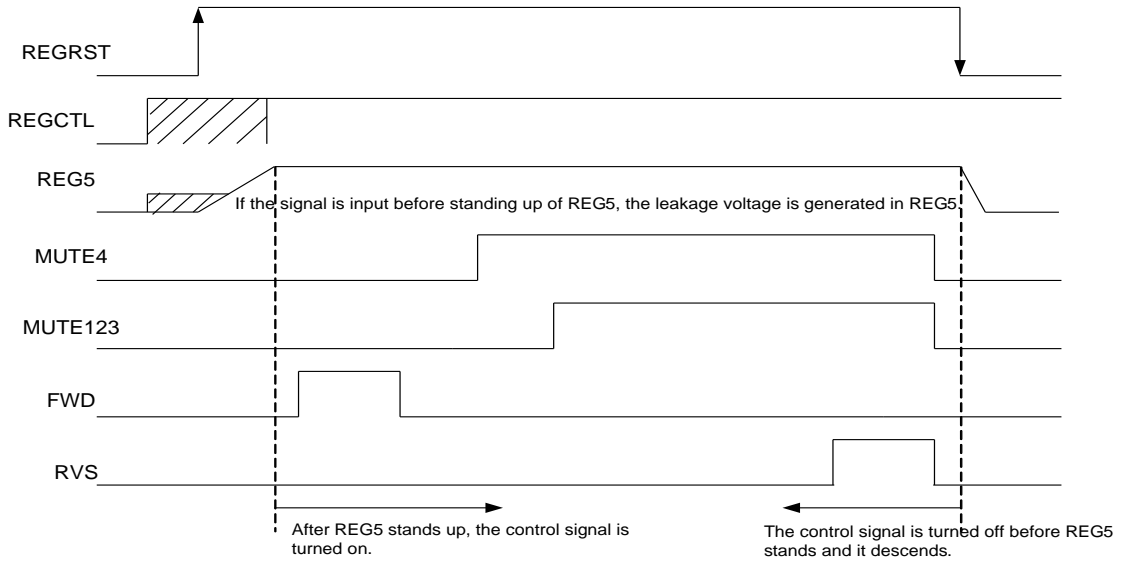

Terminal ※ where the destination of hanging the diode on the power supply side is REG5 must defend the above-mentioned sequence so as not to impress the voltage more than the voltage of REG5 terminal.
 Please insert in the cereal and use the limit resistance for the terminal when you impress the voltage more than the voltage of REG5 terminal.
 (Limit resistance 10kΩ or more is inserted in the cereal about REGCTL terminal.)
 ※Terminal where destination of hanging diode on power supply side is REG5
 REGCTL, MUTE123, MUTE4, VCI, RVS, FWD, IN1, IN2, IN3, IN4, OPIN+, OPIN-, VCTL

Method of Calculating Gain
 (a) Loading

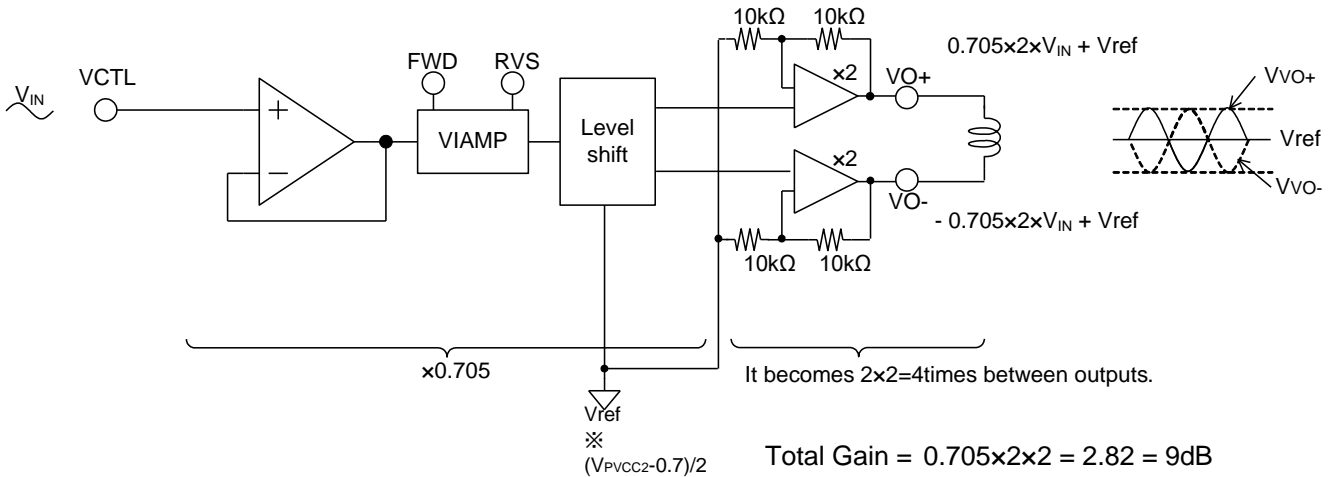

(b) Focus, Tracking, Sled, Spindle

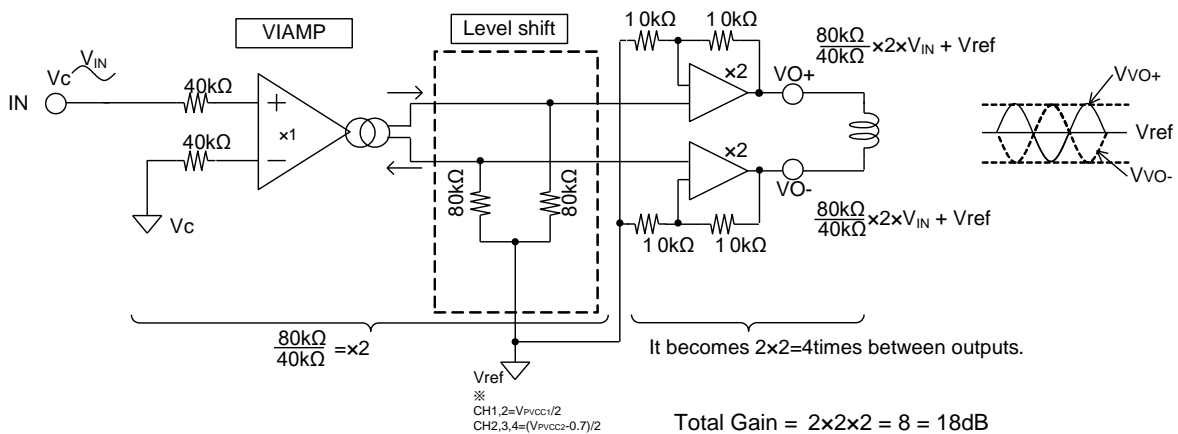

• Noise Measures

The cause of PWM driver's noise is the following.

- A. Noise from VCC and GND line
- B. Radiation noise

Measures of A

- ① Because a high current is generated by the PWM, Lower wiring impedance at driver's power supply (PVCC) and GND line (PGND) is recommended. This can be achieved by separating the power supply line of other devices from the main supply to eliminate the common impedance, and connecting it to another line.
- ② Use electrolytic capacitor with low ESR to power supply pin (PVCC1, PVCC2, PREVCC) of drivers and GND pin (PGND) to make it stable. Please connect the ceramic capacitor with a high frequency characteristic directly to the pin (or as close as possible to the IC).

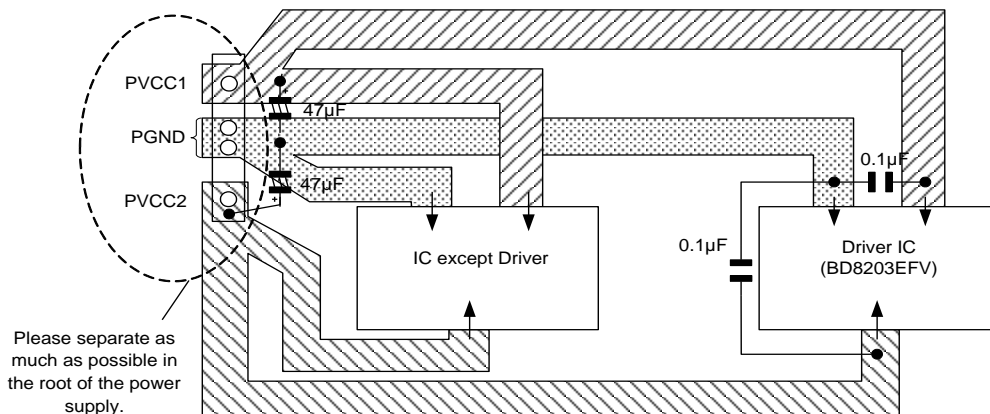

- ③ There is a method of inserting LC filter in the power supply line or GND line, when the first two measures are not sufficient to solve the noise problem.

(Example)

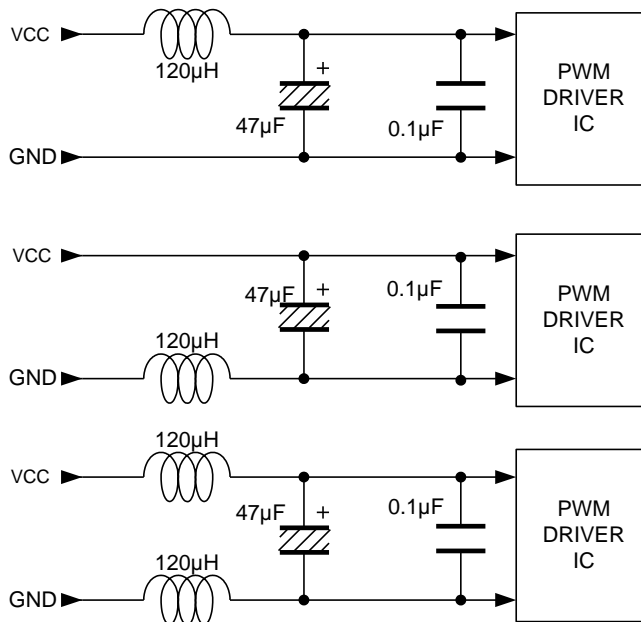

Figure 1. LC Filter Chart

- ④ In addition, there is a technique of adding a capacitor of about 2200pF (arbitrary capacitance) between each output and GND in the PWM driver. In this case, the wiring for GND must not be common with other signals.

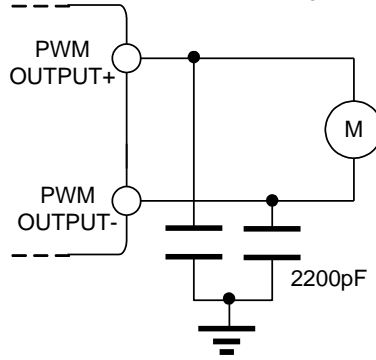

Figure 2. Snubber Circuit

3. ASO

Pin 6 to Pin 15 ASO Data (TON = 0.1sec)

$V_{PREVCC} = V_{PVCC1} = V_{PVCC2} = 15V$

$T_a = 25^\circ C$

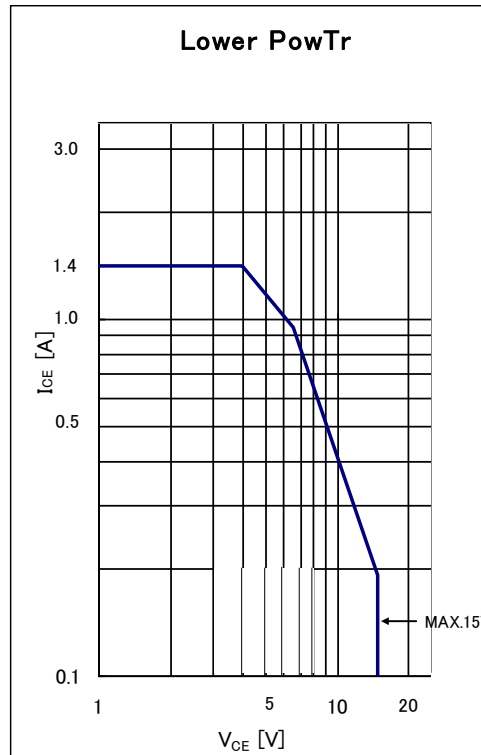
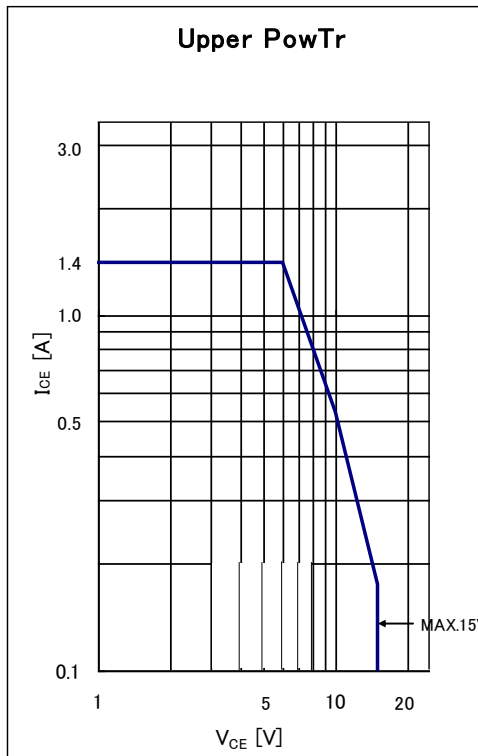
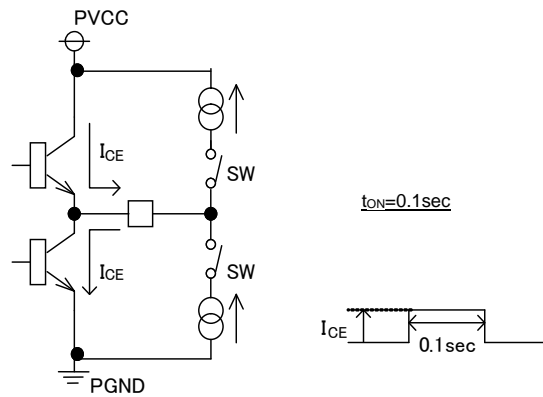

I/O Equivalent Circuits

Pin Name	Equivalent-Circuit Diagram of the Terminals
<p>VO1± VO2±</p>	
<p>VO3± VO5±</p>	
<p>VCI</p>	

I/O Equivalent Circuit – continued

Pin name	Equivalent-Circuit Diagram of the Terminals
VCO	
MUTE123, MUTE4, RVS, FWD	
REGRST	

I/O Equivalent Circuit – continued

Pin Name	Equivalent-Circuit Diagram of the Terminals
REGVAR, REGVARVCC	
REGCTL	
VO4±, VSPDL	

I/O Equivalent Circuit – continued

Pin Name	Equivalent-Circuit Diagram of the Terminals
<p>IN1, 2, 3, 4</p>	
<p>OPIN + -</p>	
<p>OPOUT</p>	

I/O Equivalent Circuit – continued

Pin Name	Equivalent-Circuit Diagram of the Terminals
VCTL	
TSDM	
REG5	

(Note) Resistance in the above-mentioned equivalent-circuit diagram of the terminals is 25°C, and a value at typical.

Operational Notes

1. Reverse Connection of Power Supply

Connecting the power supply in reverse polarity can damage the IC. Take precautions against reverse polarity when connecting the power supply, such as mounting an external diode between the power supply and the IC's power supply pins.

2. Power Supply Lines

Design the PCB layout pattern to provide low impedance supply lines. Separate the ground and supply lines of the digital and analog blocks to prevent noise in the ground and supply lines of the digital block from affecting the analog block. Furthermore, connect a capacitor to ground at all power supply pins. Consider the effect of temperature and aging on the capacitance value when using electrolytic capacitors.

3. Ground Voltage

Ensure that no pins are at a voltage below that of the ground pin at any time, even during transient condition.

4. Ground Wiring Pattern

When using both small-signal and large-current ground traces, the two ground traces should be routed separately but connected to a single ground at the reference point of the application board to avoid fluctuations in the small-signal ground caused by large currents. Also ensure that the ground traces of external components do not cause variations on the ground voltage. The ground lines must be as short and thick as possible to reduce line impedance.

5. Thermal Consideration

Should by any chance the power dissipation rating be exceeded the rise in temperature of the chip may result in deterioration of the properties of the chip. In case of exceeding this absolute maximum rating, increase the board size and copper area to prevent exceeding the Pd rating.

6. Recommended Operating Conditions

These conditions represent a range within which the expected characteristics of the IC can be approximately obtained. The electrical characteristics are guaranteed under the conditions of each parameter.

7. Inrush Current

When power is first supplied to the IC, it is possible that the internal logic may be unstable and inrush current may flow instantaneously due to the internal powering sequence and delays, especially if the IC has more than one power supply. Therefore, give special consideration to power coupling capacitance, power wiring, width of ground wiring, and routing of connections.

8. Operation Under Strong Electromagnetic Field

Operating the IC in the presence of a strong electromagnetic field may cause the IC to malfunction.

9. Testing on Application Boards

When testing the IC on an application board, connecting a capacitor directly to a low-impedance output pin may subject the IC to stress. Always discharge capacitors completely after each process or step. The IC's power supply should always be turned off completely before connecting or removing it from the test setup during the inspection process. To prevent damage from static discharge, ground the IC during assembly and use similar precautions during transport and storage.

10. Inter-pin Short and Mounting Errors

Ensure that the direction and position are correct when mounting the IC on the PCB. Incorrect mounting may result in damaging the IC. Avoid nearby pins being shorted to each other especially to ground, power supply and output pin. Inter-pin shorts could be due to many reasons such as metal particles, water droplets (in very humid environment) and unintentional solder bridge deposited in between pins during assembly to name a few.

11. Unused Input Pins

Input pins of an IC are often connected to the gate of a MOS transistor. The gate has extremely high impedance and extremely low capacitance. If left unconnected, the electric field from the outside can easily charge it. The small charge acquired in this way is enough to produce a significant effect on the conduction through the transistor and cause unexpected operation of the IC. So unless otherwise specified, unused input pins should be connected to the power supply or ground line.

Operational Notes – continued

12. Regarding the Input Pin of the IC

This monolithic IC contains P+ isolation and P substrate layers between adjacent elements in order to keep them isolated. P-N junctions are formed at the intersection of the P layers with the N layers of other elements, creating a parasitic diode or transistor. For example (refer to figure below):

When GND > Pin A and GND > Pin B, the P-N junction operates as a parasitic diode.
 When GND > Pin B, the P-N junction operates as a parasitic transistor.

Parasitic diodes inevitably occur in the structure of the IC. The operation of parasitic diodes can result in mutual interference among circuits, operational faults, or physical damage. Therefore, conditions that cause these diodes to operate, such as applying a voltage lower than the GND voltage to an input pin (and thus to the P substrate) should be avoided.

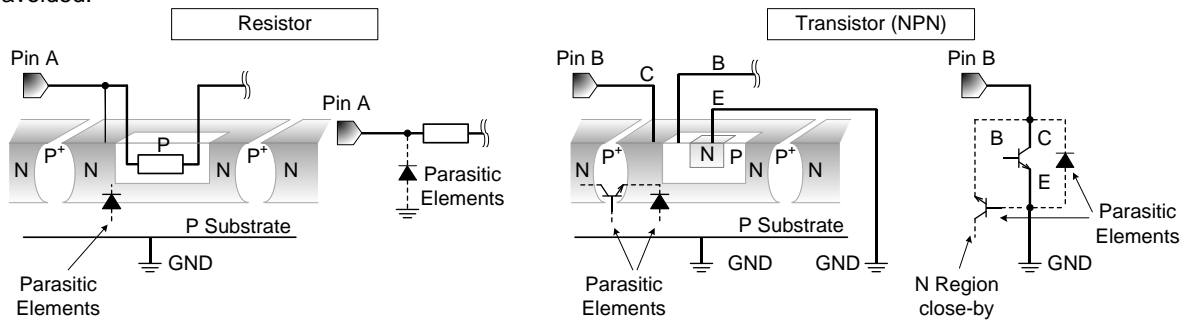

Figure 3. Example of monolithic IC structure

13. Area of Safe Operation (ASO)

Operate the IC such that the output voltage, output current, and power dissipation are all within the Area of Safe Operation (ASO).

14. Thermal Shutdown Circuit(TSD)

This IC has a built-in thermal shutdown circuit that prevents heat damage to the IC. Normal operation should always be within the IC's power dissipation rating. If however the rating is exceeded for a continued period, the junction temperature (Tj) will rise which will activate the TSD circuit that will turn OFF all output pins. When the Tj falls below the TSD threshold, the circuits are automatically restored to normal operation.

Note that the TSD circuit operates in a situation that exceeds the absolute maximum ratings and therefore, under no circumstances, should the TSD circuit be used in a set design or for any purpose other than protecting the IC from heat damage.

15. Capacitor Between Output and Ground

If a large capacitor is connected between the output pin and ground pin, current from the charged capacitor can flow into the output pin and may destroy the IC when the VCC or IN pin is shorted to ground or pulled down to 0V. Use a capacitor smaller than 0.1µF between output and ground.

16. About the capacitor between the outputs

The output current increases with reference to the change between the outputs when the capacitor is connected between the driver outputs. Therefore, please add bypass capacitor (0.1µF) as nearest as possible to the power supply (PVCC) and GND(PGND) of this IC as the route of the output current. Please select the value of the capacitor which will have no effect on the IC's normal characteristics, it is possible to pull out capacity at the low temperature happening to the electrolytic capacitor more than the capacity value of the capacitor between the outputs.

Ordering Information

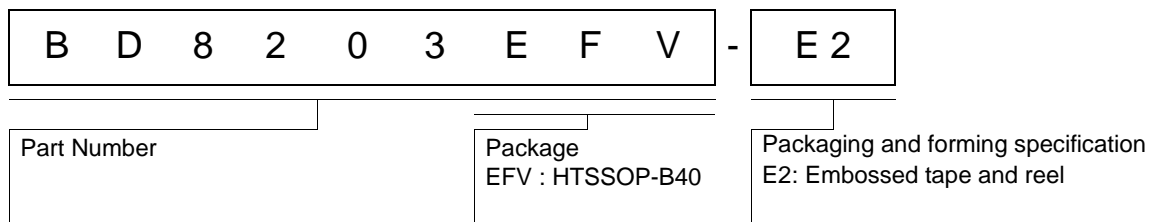

Marking Diagram

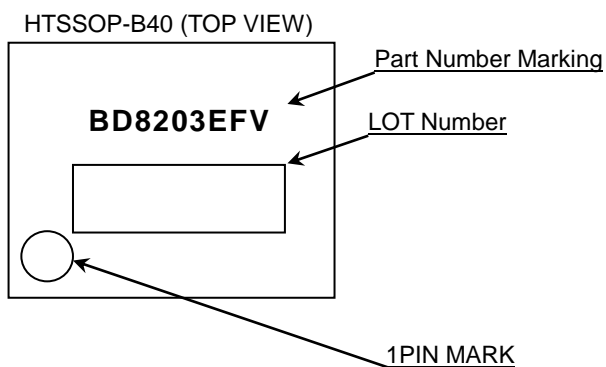

Physical Dimension Tape and Reel Information

Package Name	HTSSOP-B40
--------------	------------

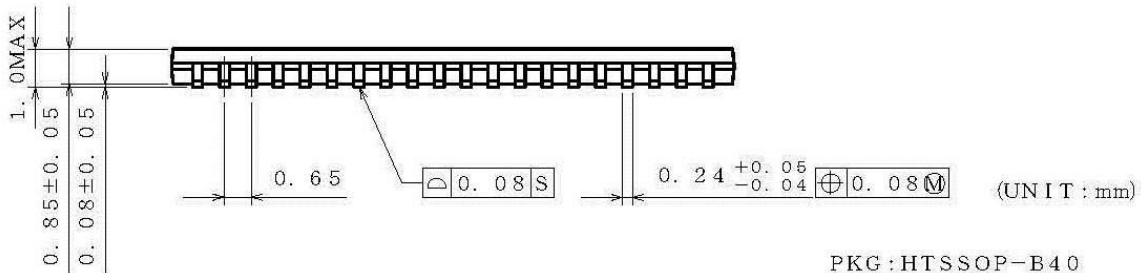
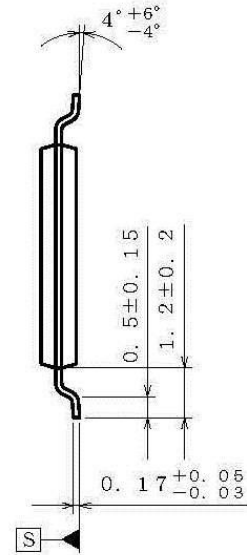
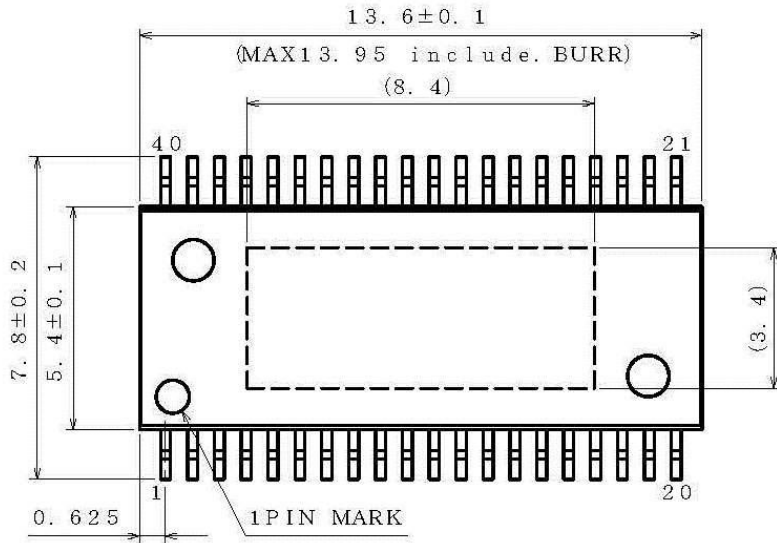

PKG: HTSSOP-B40
Drawing No. EX194-5002-2

<Tape and Reel information>

Tape	Embossed carrier tape (with dry pack)
Quantity	2000pcs
Direction of feed	E2 (The direction is the 1pin of product is at the upper left when you hold reel on the left hand and you pull out the tape on the right hand)

1pin

Reel

Direction of feed

* Order quantity needs to be multiple of the minimum quantity.

Revision History

Date	Revision	Changes
04.Nov.2015	001	New Release

Notice

Precaution on using ROHM Products

- Our Products are designed and manufactured for application in ordinary electronic equipments (such as AV equipment, OA equipment, telecommunication equipment, home electronic appliances, amusement equipment, etc.). If you intend to use our Products in devices requiring extremely high reliability (such as medical equipment ^(Note 1), transport equipment, traffic equipment, aircraft/spacecraft, nuclear power controllers, fuel controllers, car equipment including car accessories, safety devices, etc.) and whose malfunction or failure may cause loss of human life, bodily injury or serious damage to property ("Specific Applications"), please consult with the ROHM sales representative in advance. Unless otherwise agreed in writing by ROHM in advance, ROHM shall not be in any way responsible or liable for any damages, expenses or losses incurred by you or third parties arising from the use of any ROHM's Products for Specific Applications.

(Note1) Medical Equipment Classification of the Specific Applications

JAPAN	USA	EU	CHINA
CLASS III	CLASS III	CLASS II b	CLASS III
CLASS IV		CLASS III	

- ROHM designs and manufactures its Products subject to strict quality control system. However, semiconductor products can fail or malfunction at a certain rate. Please be sure to implement, at your own responsibilities, adequate safety measures including but not limited to fail-safe design against the physical injury, damage to any property, which a failure or malfunction of our Products may cause. The following are examples of safety measures:
 - Installation of protection circuits or other protective devices to improve system safety
 - Installation of redundant circuits to reduce the impact of single or multiple circuit failure
- Our Products are designed and manufactured for use under standard conditions and not under any special or extraordinary environments or conditions, as exemplified below. Accordingly, ROHM shall not be in any way responsible or liable for any damages, expenses or losses arising from the use of any ROHM's Products under any special or extraordinary environments or conditions. If you intend to use our Products under any special or extraordinary environments or conditions (as exemplified below), your independent verification and confirmation of product performance, reliability, etc. prior to use, must be necessary:
 - Use of our Products in any types of liquid, including water, oils, chemicals, and organic solvents
 - Use of our Products outdoors or in places where the Products are exposed to direct sunlight or dust
 - Use of our Products in places where the Products are exposed to sea wind or corrosive gases, including Cl₂, H₂S, NH₃, SO₂, and NO₂
 - Use of our Products in places where the Products are exposed to static electricity or electromagnetic waves
 - Use of our Products in proximity to heat-producing components, plastic cords, or other flammable items
 - Sealing or coating our Products with resin or other coating materials
 - Use of our Products without cleaning residue of flux (even if you use no-clean type fluxes, cleaning residue of flux is recommended); or Washing our Products by using water or water-soluble cleaning agents for cleaning residue after soldering
 - Use of the Products in places subject to dew condensation
- The Products are not subject to radiation-proof design.
- Please verify and confirm characteristics of the final or mounted products in using the Products.
- In particular, if a transient load (a large amount of load applied in a short period of time, such as pulse. is applied, confirmation of performance characteristics after on-board mounting is strongly recommended. Avoid applying power exceeding normal rated power; exceeding the power rating under steady-state loading condition may negatively affect product performance and reliability.
- De-rate Power Dissipation depending on ambient temperature. When used in sealed area, confirm that it is the use in the range that does not exceed the maximum junction temperature.
- Confirm that operation temperature is within the specified range described in the product specification.
- ROHM shall not be in any way responsible or liable for failure induced under deviant condition from what is defined in this document.

Precaution for Mounting / Circuit board design

- When a highly active halogenous (chlorine, bromine, etc.) flux is used, the residue of flux may negatively affect product performance and reliability.
- In principle, the reflow soldering method must be used on a surface-mount products, the flow soldering method must be used on a through hole mount products. If the flow soldering method is preferred on a surface-mount products, please consult with the ROHM representative in advance.

For details, please refer to ROHM Mounting specification

Precautions Regarding Application Examples and External Circuits

1. If change is made to the constant of an external circuit, please allow a sufficient margin considering variations of the characteristics of the Products and external components, including transient characteristics, as well as static characteristics.
2. You agree that application notes, reference designs, and associated data and information contained in this document are presented only as guidance for Products use. Therefore, in case you use such information, you are solely responsible for it and you must exercise your own independent verification and judgment in the use of such information contained in this document. ROHM shall not be in any way responsible or liable for any damages, expenses or losses incurred by you or third parties arising from the use of such information.

Precaution for Electrostatic

This Product is electrostatic sensitive product, which may be damaged due to electrostatic discharge. Please take proper caution in your manufacturing process and storage so that voltage exceeding the Products maximum rating will not be applied to Products. Please take special care under dry condition (e.g. Grounding of human body / equipment / solder iron, isolation from charged objects, setting of Ionizer, friction prevention and temperature / humidity control).

Precaution for Storage / Transportation

1. Product performance and soldered connections may deteriorate if the Products are stored in the places where:
 - [a] the Products are exposed to sea winds or corrosive gases, including Cl₂, H₂S, NH₃, SO₂, and NO₂
 - [b] the temperature or humidity exceeds those recommended by ROHM
 - [c] the Products are exposed to direct sunshine or condensation
 - [d] the Products are exposed to high Electrostatic
2. Even under ROHM recommended storage condition, solderability of products out of recommended storage time period may be degraded. It is strongly recommended to confirm solderability before using Products of which storage time is exceeding the recommended storage time period.
3. Store / transport cartons in the correct direction, which is indicated on a carton with a symbol. Otherwise bent leads may occur due to excessive stress applied when dropping of a carton.
4. Use Products within the specified time after opening a humidity barrier bag. Baking is required before using Products of which storage time is exceeding the recommended storage time period.

Precaution for Product Label

QR code printed on ROHM Products label is for ROHM's internal use only.

Precaution for Disposition

When disposing Products please dispose them properly using an authorized industry waste company.

Precaution for Foreign Exchange and Foreign Trade act

Since concerned goods might be fallen under listed items of export control prescribed by Foreign exchange and Foreign trade act, please consult with ROHM in case of export.

Precaution Regarding Intellectual Property Rights

1. All information and data including but not limited to application example contained in this document is for reference only. ROHM does not warrant that foregoing information or data will not infringe any intellectual property rights or any other rights of any third party regarding such information or data.
2. ROHM shall not have any obligations where the claims, actions or demands arising from the combination of the Products with other articles such as components, circuits, systems or external equipment (including software).
3. No license, expressly or implied, is granted hereby under any intellectual property rights or other rights of ROHM or any third parties with respect to the Products or the information contained in this document. Provided, however, that ROHM will not assert its intellectual property rights or other rights against you or your customers to the extent necessary to manufacture or sell products containing the Products, subject to the terms and conditions herein.

Other Precaution



1. This document may not be reprinted or reproduced, in whole or in part, without prior written consent of ROHM.
2. The Products may not be disassembled, converted, modified, reproduced or otherwise changed without prior written consent of ROHM.
3. In no event shall you use in any way whatsoever the Products and the related technical information contained in the Products or this document for any military purposes, including but not limited to, the development of mass-destruction weapons.
4. The proper names of companies or products described in this document are trademarks or registered trademarks of ROHM, its affiliated companies or third parties.

General Precaution

1. Before you use our Products, you are requested to carefully read this document and fully understand its contents. ROHM shall not be in any way responsible or liable for failure, malfunction or accident arising from the use of any ROHM's Products against warning, caution or note contained in this document.
2. All information contained in this document is current as of the issuing date and subject to change without any prior notice. Before purchasing or using ROHM's Products, please confirm the latest information with a ROHM sales representative.
3. The information contained in this document is provided on an "as is" basis and ROHM does not warrant that all information contained in this document is accurate and/or error-free. ROHM shall not be in any way responsible or liable for any damages, expenses or losses incurred by you or third parties resulting from inaccuracy or errors of or concerning such information.

Looking for pricing, stock, or lifecycle information?

Click below to explore more details on WIN SOURCE:

-  [View BD8203EFV-E2 on WIN SOURCE](#)
-  [Rohm Semiconductor](#) Information

Optimize Your Supply Chain with WIN SOURCE Solutions

-  Global Sourcing Solution
-  Obsolete Management
-  Cost Control Management
-  Shortage Management
-  Alternative Solution
-  Excess Inventory Management