



**THE DATASHEET OF  
BD8143MUV-E2**



## Power Supply IC Series for TFT LCD Panels

# High-precision Gamma Correction IC with built-in DAC

**BD8143MUV**

No.09035EBT08

**●Description**

This gamma correction voltage generation IC feature built-in DACs and provide a 1chip solution with setting control via serial communications, a high-precision 10-bitDAC, and Buffer Amp (12ch).

**●Features**

- 1) 1chip design means fewer components
- 2) Built-in 10bit DAC
- 3) DAC output Buffer AMP (12ch)
- 4) Amp input select (CTL)
- 5) 3-line serial interface control
- 6) Thermal shut down
- 7) Power ON Reset Circuit
- 8) VQFN032V5050 Package

**●Applications**

These ICs can be used with TFT LCD Panels used by Large-Screen and High-Definition LCD TVs.

**●Absolute maximum ratings (Ta=25°C)**

Parameter	Symbol	Limit	Unit
Power Supply Voltage 1	DVCC	7	V
Power Supply Voltage 2	VCC	20	V
REFIN Voltage	REF	20	V
Amplifier Drive Current	Io	30 * <sup>1</sup>	mA
Junction Temperature	Tjmax	150	°C
Power Dissipation	Pd	2440 * <sup>2</sup>	mW
Operating Temperature Range	Topr	-40~+105	°C
Storage Temperature Range	Tstg	-55~+150	°C

\*1 Pd, should not be exceeded.

\*2 Reduced by 19.52mW/°C over 25°C, when mounted on a glass epoxy board.  
(4-layer 74.2×74.2×1.6mm).

**●Operating Condition (Ta=-40°C~105°C)**

Parameter	Symbol	Limit		Unit
		MIN	MAX	
Power Supply Voltage 1	DVCC	2.3	5.5	V
Power Supply Voltage 2	VCC	8	18	V
REFIN Voltage	REF	8	18	V
AMP0 Drive Current	IoA	-40	-	mA
AMP1~10 Drive Current	IoB	-20	20	mA
AMP11 Drive Current	IoC	-	40	mA
Serial CLK Frequency	fCLK	-	5	MHz
OSC Frequency	Fosc	-	200	kHz

## ●Electrical Characteristics (Unless otherwise specified, Ta=25°C, DVCC=3.3V, VCC=15V)

Parameter	Symbol	Limit			Unit	Conditions
		MIN	TYP	MAX		
<b>[REFIN]</b>						
Sink Current	Iref		90	200	μA	REF=10V
<b>[γ CORRECTION AMP]</b>						
Source Drive Current (AMP0)	IooA			-60	mA	DAC=7V, OUT0=13V
Source Drive Current (AMP1~10)	IooB			-30	mA	DAC=3.5V, OUT1~10=0V
Source Drive Current (AMP11)	IooC			-10	mA	DAC=0.5V, OUT11=0V
Sink Drive Current (AMP0)	IoiA	10			mA	DAC=7V, OUT0=15V
Sink Drive Current (AMP1~10)	IoiB	30			mA	DAC=3.5V, OUT1~10=15V
Sink Drive Current (AMP11)	IoiC	60			mA	DAC=0.5V, OUT11=2V
Load regulation (OUT0)	ΔV-A		10		mV	Io=0mA~ -35mA, OUTx=6V
Load regulation (OUT1~10)	ΔV-B		10		mV	Io=-15mA~15mA, OUTx=6V
Load regulation (OUT11)	ΔV-C		10		mV	Io=0mA~35mA, OUTx=6V
Slew Rate	SR		3		V/μs	
OUT Voltage High (OUT0)	VOH-A	VCC-0.4	VCC-0.15	-	V	Io=-35mA
OUT Voltage High (OUT1~10)	VOH-B		VCC-0.75	-	V	Io=-15mA
OUT Voltage High (OUT11)	VOH-C		VCC-0.75	-	V	Io=-15mA
OUT Voltage Low (OUT0)	VOL-A	-	0.75		V	Io=15mA
OUT Voltage Low (OUT1~10)	VOL-B	-	0.75		V	Io=15mA
OUT Voltage Low (OUT11)	VOL-C	-	0.1	0.2	V	Io=35mA
<b>[DAC]</b>						
Resolution Coding	Res		10		Bit	
Non-Linear Error (INL)	LE	-2	-	2	LSB	Error with ideal straight Range 00A~3F5
Differential Error (DNL)	DLE	-2	-	2	LSB	Error with ideal amount of Increase in 1LSB Range 00A~3F5
<b>[OSC]</b>						
OSC Frequency	fosc	-	100	-	kHz	Internal oscillator mode
<b>[CONTROL SIGNAL]</b>						
Sink Current	Ictl		16.5		μA	VIN=3.3V
Threshold Voltage	VTH	DVCC × 0.2		DVCC × 0.8	V	
<b>[CONTROL]</b>						
OUT0 Voltage	Vpre0	-	REFIN X 12/13	-	V	CTL="LOW"
OUT1 Voltage	Vpre1	-	REFIN X 11/13	-	V	CTL="LOW"
OUT2 Voltage	Vpre2	-	REFIN X 10/13	-	V	CTL="LOW"
OUT3 Voltage	Vpre3	-	REFIN X 9/13	-	V	CTL="LOW"
OUT4 Voltage	Vpre4	-	REFIN X 8/13	-	V	CTL="LOW"
OUT5 Voltage	Vpre5	-	REFIN X 7/13	-	V	CTL="LOW"
OUT6 Voltage	Vpre6	-	REFIN X 6/13	-	V	CTL="LOW"
OUT7 Voltage	Vpre7	-	REFIN X 5/13	-	V	CTL="LOW"
OUT8 Voltage	Vpre8	-	REFIN X 4/13	-	V	CTL="LOW"
OUT9 Voltage	Vpre9	-	REFIN X 3/13	-	V	CTL="LOW"
OUT10 Voltage	Vpre10	-	REFIN X 2/13	-	V	CTL="LOW"
OUT11 Voltage	Vpre11	-	REFIN X 1/13	-	V	CTL="LOW"
<b>[WHOLE DEVICE]</b>						
VDAC Detection Voltage	Vdet	2.6	3.2	3.6	V	
Circuit Current	ICC		5		mA	CTL="LOW"

○This product is not designed for protection against radio active rays.

● Pin No

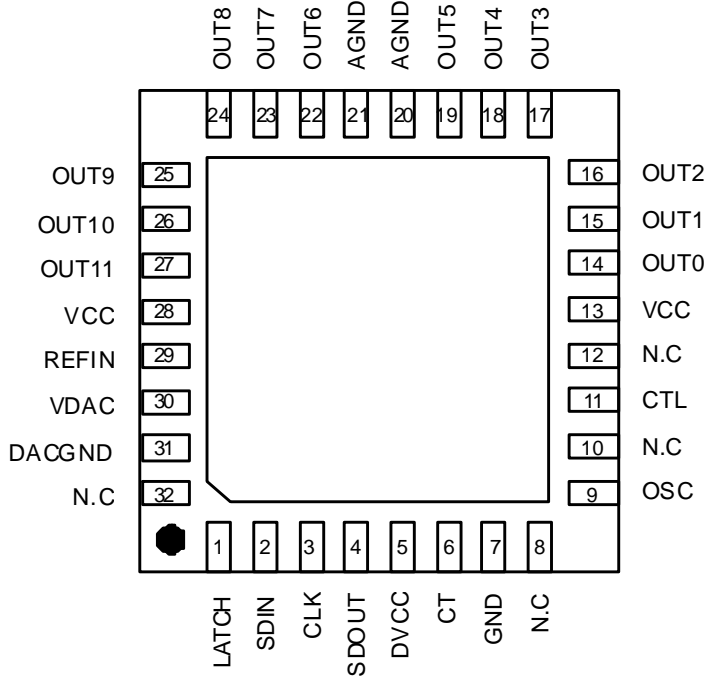

● Block Diagram

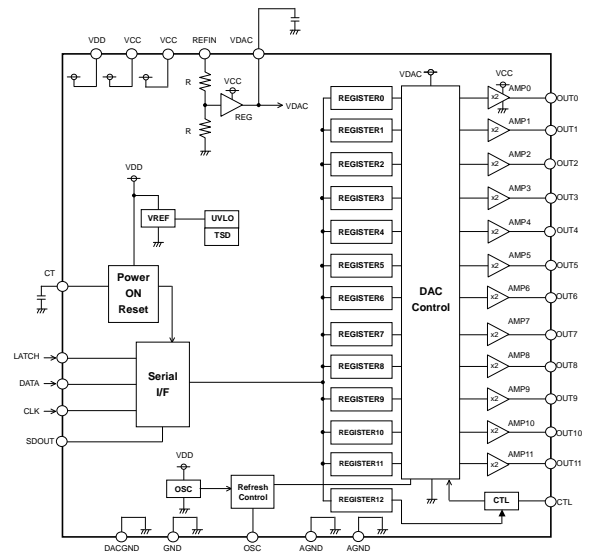

Fig.1 Pin No. & Block Diagram

● Pin NO. & Function Table

PIN No.	Pin Name	Function	PIN No.	Pin Name	Function
1	LATCH	LATCH signal input	17	OUT3	Gamma 3 output
2	SDIN	DATA signal input	18	OUT4	Gamma 4 output
3	CLK	CLK signal input	19	OUT5	Gamma 5 output
4	SDOUT	DATA signal output	20	AGND	Ground for Buffer AMP
5	DVCC	Digital Power Supply	21	AGND	Ground for Buffer AMP
6	CT	Capacitor connection for Power on Reset	22	OUT6	Gamma 6 output
7	GND	Ground	23	OUT7	Gamma 7 output
8	N.C	-	24	OUT8	Gamma 8 output
9	OSC	DAC Synchronized clock inout	25	OUT9	Gamma 9 output
10	N.C	-	26	OUT10	Gamma 10 output
11	CTL	Output control signal input	27	OUT11	Gamma 11 output
12	N.C	-	28	VCC	Power Supply for Buffer AMP
13	VCC	Power Supply for Buffer AMP	29	REFIN	DAC reference input
14	OUT0	Gamma 0 output	30	VDAC	DAC Voltage output
15	OUT1	Gamma 1 output	31	DACGND	Ground for DAC
16	OUT2	Gamma 2 output	32	N.C	-

**●Block Operation**

- REG  
REG amplifies the voltage applied to REFIN by 0.5x and output it to the VDAC pin. Connect a 1μF phase compensation capacitor to the VDAC pin.
- DAC Control  
DAC Control converts the 10-bit digital signal read to the register to a voltage.
- Amp  
Amp amplifies the voltage output from DAC Control by 2x. Input includes sample & hold function, refreshed by OSC.
- OSC  
The OSC generates the frequency that determines the Amp's refresh time.  
External input can be selected using serial input.
- Power On Reset  
When the digital power supply DVCC is activated, each IC generates a reset signal to initialize the serial interface, registers.  
Adding a 1,000 pF capacitor to the CT pin ensures that reset operation can be performed reliably, without regard to the speed with which the power supply starts up.
- VREF  
This block generates the internal reference voltage.
- TSD(Thermal Shut Down)  
The TSD circuit turns output off when the chip temperature reaches or exceeds approximately 175°C(TYP) in order to prevent thermal destruction or thermal runaway. When the chip returns to a specified temperature, the circuit resets.  
The TSD circuit is designed only to protect the IC itself. Application thermal design should ensure operation of the IC below the thermal shutdown junction temperature of approximately 150°C(TYP).
- CTL  
CTL signal can select Amp input. If CTL="L", each output voltage is fixed at REFIN voltage divided 13th equality.  
IF CTL="H", each Amp input connect DAC output, and each output comply with each register.
- Register  
A serial signal (consisting of 10-bit gamma correction voltage values) input using the serial interface is held for each register address. Data is initialized by the reset signal generated during a power-on reset.
- Serial I/F  
The serial interface uses a 3-line serial data format (LATCH, CLK, SDIN). It is used to set gamma correction voltages, specify register addresses, and select OSC I/O.

●Serial Communication

The serial data control block is composed of Shift-Register, DAC Register and DAC circuit.  
 The DAC register memorizes data from the serial interface (LATCH, CLK and SDIN).  
 The DAC circuit makes control voltage from the register output and it outputs to the each block. The DAC register value turns back the preset value when Power Supply starts up.  
 Then, beginning 1bit of SDIN is always 0, because it is for test. Next 1bit switches OSC mode.  
 If input 0, OSC mode is internal mode (the frequency is 100kHz). If input 1, it is external one that require external clock.

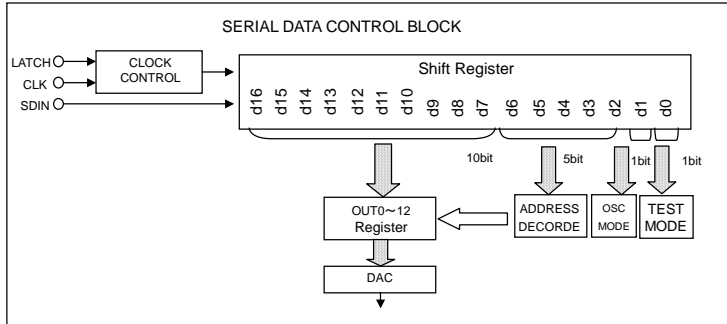

Fig.2 SERIAL BLOCK

①TIMING OF SERIAL COMMUNICATION

The 17 bits Serial data from SDIN terminal is loaded to Shift-Register at the rise edge of CLK, and these data is loaded to DAC Register at the rise edge of LATCH.  
 If serial data period is less than 17 bits while LATCH state is LOW, the serial data is not memorized. If serial data period is more than 17 bits while LATCH state is LOW, last 17 bits are effective.

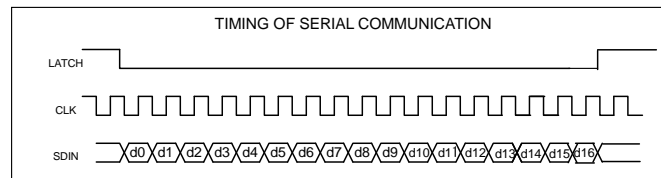

Fig.3 TIMING OF SERIAL COMMUNICATION

②SERIAL DATA

The composition of SERIAL DATA INPUT(SDIN)

First →															→ Last	
d0	d1	d2	d3	d4	d5	d6	d7	d8	d9	d10	d11	d12	d13	d14	d15	d16
0	X	Register Address					DATA									

REGISTER NAME	ADDRESS					FUNCTION	PRESET VALUE		
	d2	d3	d4	d5	d6		d7~d16		
Register 0	0	0	0	0	0	OUT0 Voltage of control	00	0000	0000
Register 1	0	0	0	0	1	OUT1 Voltage of control	00	0000	0000
Register 2	0	0	0	1	0	OUT2 Voltage of control	00	0000	0000
Register 3	0	0	0	1	1	OUT3 Voltage of control	00	0000	0000
Register 4	0	0	1	0	0	OUT4 Voltage of control	00	0000	0000
Register 5	0	0	1	0	1	OUT5 Voltage of control	00	0000	0000
Register 6	0	0	1	1	0	OUT6 Voltage of control	00	0000	0000
Register 7	0	0	1	1	1	OUT7 Voltage of control	00	0000	0000
Register 8	0	1	0	0	0	OUT8 Voltage of control	00	0000	0000
Register 9	0	1	0	0	1	OUT9 Voltage of control	00	0000	0000
Register 10	0	1	0	1	0	OUT10 Voltage of control	00	0000	0000
Register 11	0	1	0	1	1	OUT11 Voltage of control	00	0000	0000
Register 12(*)	0	1	1	0	0	-	00	0000	0000

(\*)IF Register 12 is loaded at DATA=101010000(2A0h), each output comply with each register regardless of CTL signal.

●Serial Communication Timing Chart

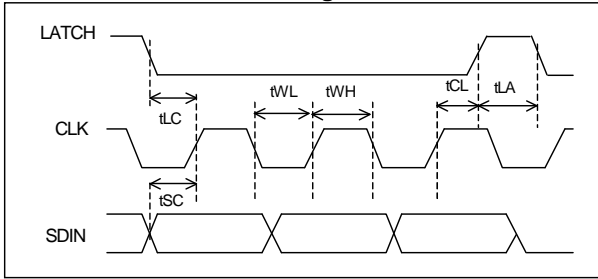

Fig.4

●Timing Standard Value

Parameter	Symbol	LIMIT			Unit
		Min.	Typ.	Max.	
LATCH Set up time	t <sub>LC</sub>	0.1	—	—	us
SDIN Set up time	t <sub>SC</sub>	0.1	—	—	us
CLK "H" time	t <sub>WH</sub>	0.1	—	—	us
CLK "L" time	t <sub>WL</sub>	0.1	—	—	us
LATCH hold time	t <sub>CL</sub>	0.1	—	—	us
LATCH "H" time	t <sub>LA</sub>	0.6	—	—	us

●Setting  $\gamma$ -Correction

Formula (1) shows the relationship between  $\gamma$  output voltage (OUT0~OUT11) and DAC digital value.

$$\text{Output Voltage(OUT0~OUT11)} = \{((\text{DAC digital value} + 1) / 1024) \times (\text{REFIN} / 2) - 10\text{mV}\} \times 2.0025 \quad \dots (1)$$

●Power Supply Sequence

Digital power supply DVCC must be supplied earlier than VCC for the prevent of wrong behavior. The serial data must be input after cancellation of "Power on Reset". When turn off power supply, VCC must be done earlier than DVCC.

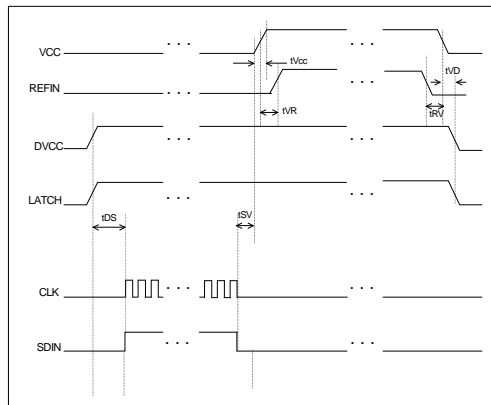

Fig.5 Power Supply Sequence

●Power Supply Sequence Standard Value

Parameter	Symbol	LIMIT			Unit	Condition
		Min.	Typ.	Max.		
Timing of serial data input	t <sub>DS</sub>	100	-	-	μs	Cct=1000pF
Timing of VCC ON	t <sub>SV</sub>	-	10	-	μs	
Timing of REFIN ON	t <sub>VR</sub>	0	10	-	μs	
Timing of REFIN OFF	t <sub>RV</sub>	0	10	-	μs	
Timing of VCC OFF	t <sub>VD</sub>	0	10	-	μs	
VCC rise time	t <sub>VCC</sub>	1	-	-	ms	

●Data writing time for register

Data writing time for register depend on frequency of CLK. Below formula shows data writing time for all registers.  
 (Because data writing time for a register is needed at 17bit data + LATCH "H" time.)

$$18 \text{ CLK} \times \frac{1}{f_{\text{CLK}} [\text{MHz}]} \times 12\text{ch} \quad [\mu\text{s}]$$

●Refresh time of Amp input

Each Amp input have sample & hold function refreshed by OSC frequency (fosc).  
 Below formula shows refresh cycle.

$$\frac{1}{f_{\text{osc}} [\text{kHz}]} \times 12\text{ch} \quad [\mu\text{s}]$$

When internal OSC mode, fosc=100kHz (Typ).

●Function of selecting Amp input

This IC can select Amp input by CTL signal. If CTL="L", Amp input is connected to resistance division of REFIN voltage. IF CTL="H", connected to DAC output. When VCC(REFIN) supplies with CTL="L", it is possible to start up without opposite Voltage of each output. Then, if the CTL signal changes "H" after 1ms and over since VCC(REFIN) supplied and data send finished, start up sequence should be below Fig.

(\*Amp input is connected to DAC output not only by CTL="H", but also DATA=1010100000(2A0h) sended to Register 12. Also in this case, please send DATA=1010100000(2A0h) to Register 12 after 1ms and over since VCC(REFIN) supplied And output data send finished, at this time CTL="L".)

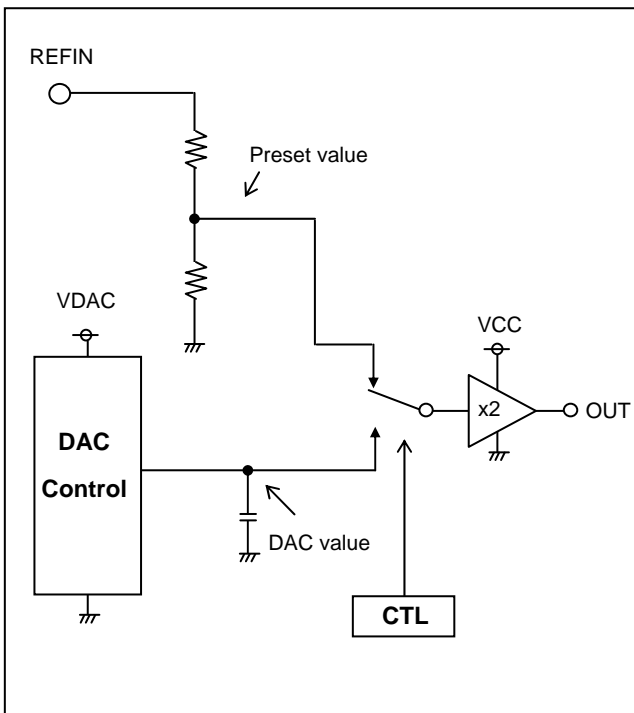

Fig.6 Selecting Amp input block diagram

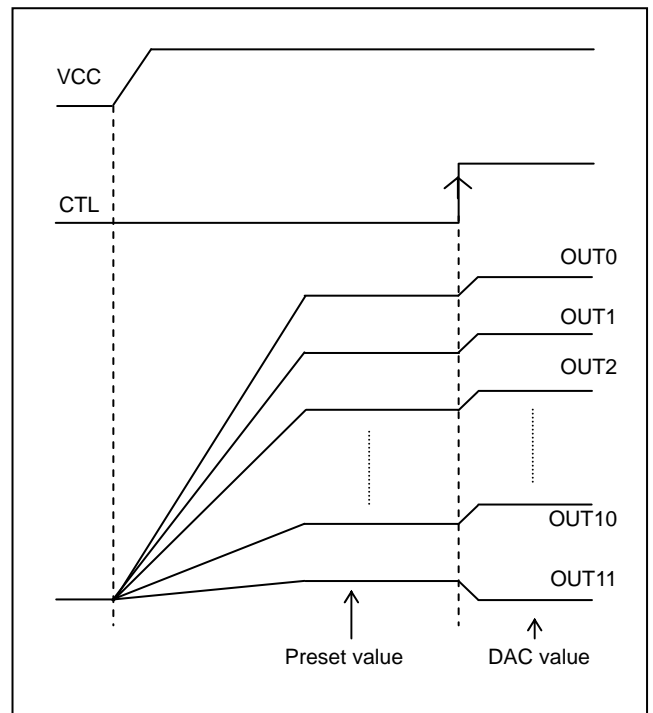

Fig.7 Start up sequence

● Input Output Circuit (BD8143MUV)

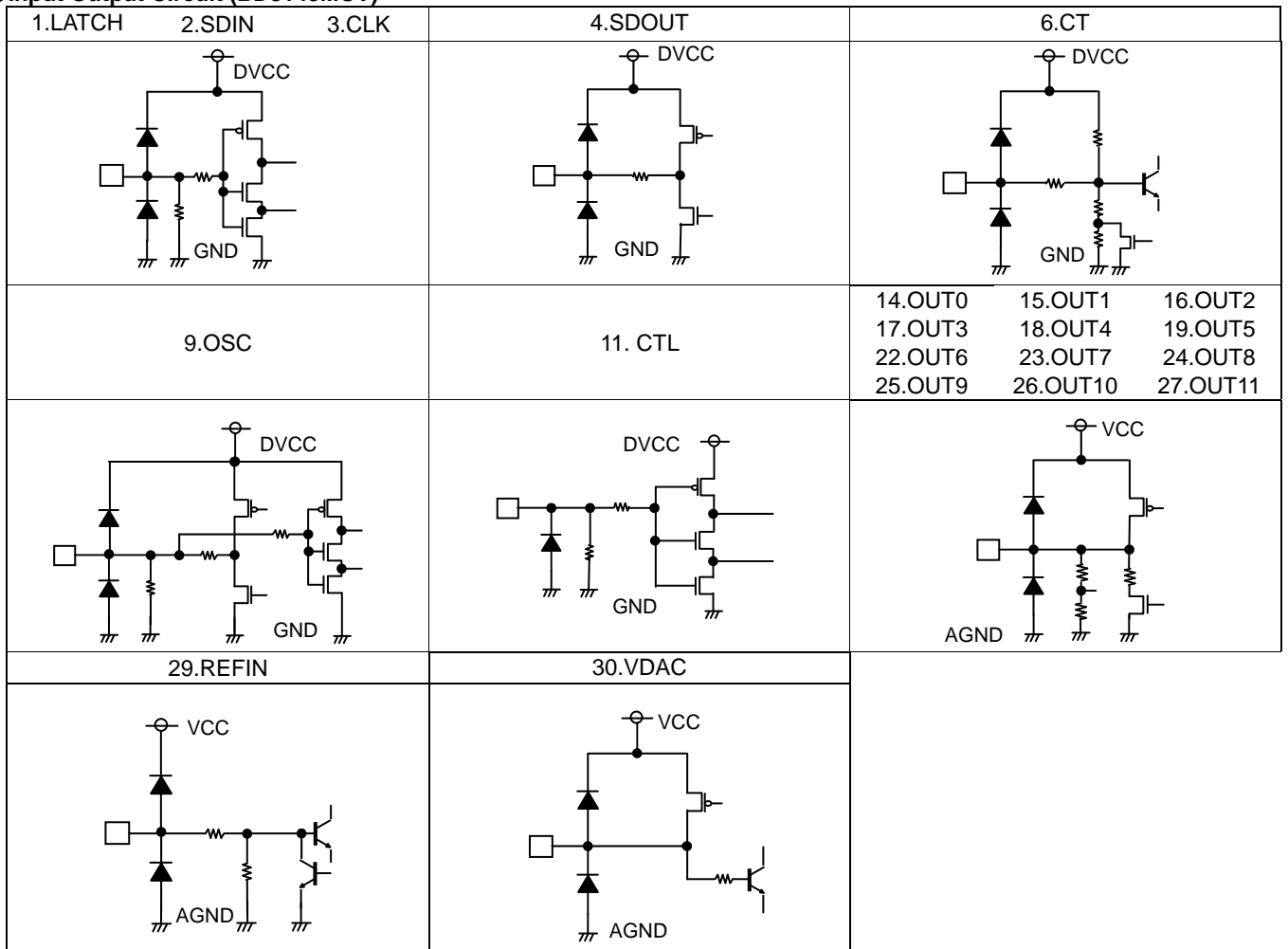

Fig.8

### ●Notes for use

- 1) Absolute maximum ratings  
Use of the IC in excess of absolute maximum ratings such as the applied voltage or operating temperature range may result in IC damage. Assumptions should not be made regarding the state of the IC (short mode or open mode) when such damage is suffered. A physical safety measure such as a fuse should be implemented when use of the IC in a special mode where the absolute maximum ratings may be exceeded is anticipated.
- 2) GND potential  
Ensure a minimum GND pin potential in all operating conditions.
- 3) Setting of heat  
Use a thermal design that allows for a sufficient margin in light of the power dissipation ( $P_d$ ) in actual operating conditions.
- 4) Pin short and mistake fitting  
Use caution when orienting and positioning the IC for mounting on printed circuit boards. Improper mounting may result in damage to the IC. Shorts between output pins or between output pins and the power supply and GND pins caused by the presence of a foreign object may result in damage to the IC.
- 5) Actions in strong magnetic field  
Use caution when using the IC in the presence of a strong magnetic field as doing so may cause the IC to malfunction.
- 6) Testing on application boards  
When testing the IC on an application board, connecting a capacitor to a pin with low impedance subjects the IC to stress. Always discharge capacitors after each process or step. Ground the IC during assembly steps as an antistatic measure, and use similar caution when transporting or storing the IC. Always turn the IC's power supply off before connecting it to or removing it from a jig or fixture during the inspection process.
- 7) Ground wiring patterns  
When using both small signal and large current GND patterns, it is recommended to isolate the two ground patterns, placing a single ground point at the application's reference point so that the pattern wiring resistance and voltage variations caused by large currents do not cause variations in the small signal ground voltage. Be careful not to change the GND wiring patterns of any external components.
- 8) Regarding input pin of the IC  
This monolithic IC contains P+ isolation and P substrate layers between adjacent elements in order to keep them isolated. P/N junctions are formed at the intersection of these P layers with the N layers of other elements to create a variety of parasitic elements. For example, when the resistors and transistors are connected to the pins as shown in below Fig.9, a parasitic diode or a transistor operates by inverting the pin voltage and GND voltage. The formation of parasitic elements as a result of the relationships of the potentials of different pins is an inevitable result of the IC's architecture. The operation of parasitic elements can cause interference with circuit operation as well as IC malfunction and damage. For these reasons, it is necessary to use caution so that the IC is not used in a way that will trigger the operation of parasitic elements such as by the application of voltages lower than the GND (P substrate) voltage to input and output pins.

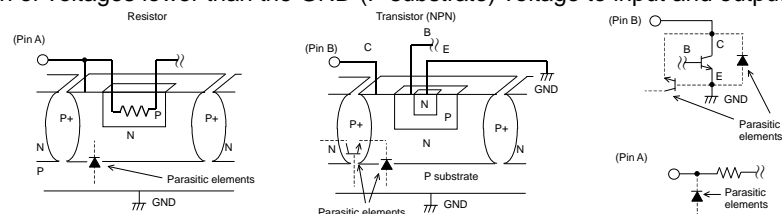

Fig.9 Example of a Simple Monolithic IC Architecture

- 9) Overcurrent protection circuits  
An overcurrent protection circuit designed according to the output current is incorporated for the prevention of IC damage that may result in the event of load shorting. This protection circuit is effective in preventing damage due to sudden and unexpected accidents. However, the IC should not be used in applications characterized by the continuous operation or transitioning of the protection circuits. At the time of thermal designing, keep in mind that the current capacity has negative characteristics to temperatures.
- 10) Thermal shutdown circuit (TSD)  
This IC incorporates a built-in TSD circuit for the protection from thermal destruction. The IC should be used within the specified power dissipation range. However, in the event that the IC continues to be operated in excess of its power dissipation limits, the attendant rise in the chip's junction temperature  $T_j$  will trigger the TSD circuit to turn off all output power elements. The circuit automatically resets once the junction temperature  $T_j$  drops. Operation of the TSD circuit presumes that the IC's absolute maximum ratings have been exceeded. Application designs should never make use of the TSD circuit.
- 11) Testing on application boards  
At the time of inspection of the installation boards, when the capacitor is connected to the pin with low impedance, be sure to discharge electricity per process because it may load stresses to the IC. Always turn the IC's power supply off before connecting it to or removing it from a jig or fixture during the inspection process. Ground the IC during assembly steps as an antistatic measure, and use similar caution when transporting or storing the IC.
- 12) Push Current  
This IC may rush current momentarily by power supply order or delay, use caution about power supply coupling capacitor, width or routing of VCC, GND patterns

●Ordering part number

B	D
---	---

Part No.

8	1	4	3
---	---	---	---

Part No.

M	U	V
---	---	---

Package  
MUV: VQFN032V5050

E	2
---	---

Packaging and forming specification  
E2: Embossed tape and reel

VQFN032V5050

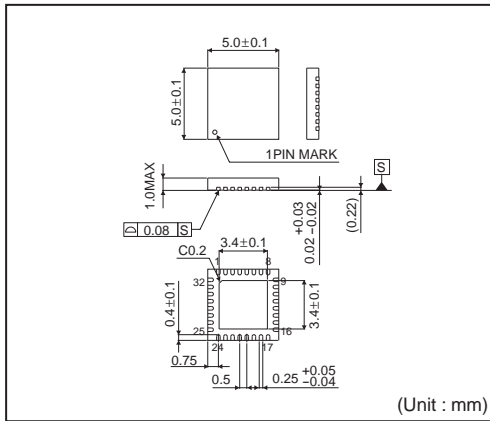

<Tape and Reel information>

Tape	Embossed carrier tape
Quantity	2500pcs
Direction of feed	E2 (The direction is the 1pin of product is at the upper left when you hold reel on the left hand and you pull out the tape on the right hand )

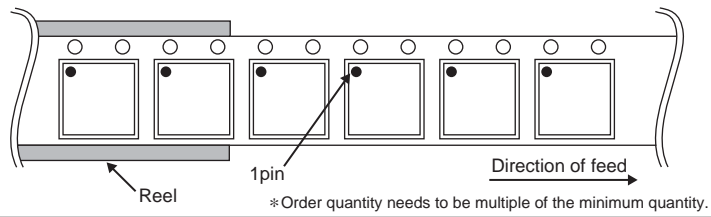

# Notice

## Precaution on using ROHM Products

- Our Products are designed and manufactured for application in ordinary electronic equipments (such as AV equipment, OA equipment, telecommunication equipment, home electronic appliances, amusement equipment, etc.). If you intend to use our Products in devices requiring extremely high reliability (such as medical equipment <sup>(Note 1)</sup>, transport equipment, traffic equipment, aircraft/spacecraft, nuclear power controllers, fuel controllers, car equipment including car accessories, safety devices, etc.) and whose malfunction or failure may cause loss of human life, bodily injury or serious damage to property ("Specific Applications"), please consult with the ROHM sales representative in advance. Unless otherwise agreed in writing by ROHM in advance, ROHM shall not be in any way responsible or liable for any damages, expenses or losses incurred by you or third parties arising from the use of any ROHM's Products for Specific Applications.

(Note1) Medical Equipment Classification of the Specific Applications

JAPAN	USA	EU	CHINA
CLASS III	CLASS III	CLASS II b	CLASS III
CLASS IV		CLASS III	

- ROHM designs and manufactures its Products subject to strict quality control system. However, semiconductor products can fail or malfunction at a certain rate. Please be sure to implement, at your own responsibilities, adequate safety measures including but not limited to fail-safe design against the physical injury, damage to any property, which a failure or malfunction of our Products may cause. The following are examples of safety measures:
  - Installation of protection circuits or other protective devices to improve system safety
  - Installation of redundant circuits to reduce the impact of single or multiple circuit failure
- Our Products are designed and manufactured for use under standard conditions and not under any special or extraordinary environments or conditions, as exemplified below. Accordingly, ROHM shall not be in any way responsible or liable for any damages, expenses or losses arising from the use of any ROHM's Products under any special or extraordinary environments or conditions. If you intend to use our Products under any special or extraordinary environments or conditions (as exemplified below), your independent verification and confirmation of product performance, reliability, etc. prior to use, must be necessary:
  - Use of our Products in any types of liquid, including water, oils, chemicals, and organic solvents
  - Use of our Products outdoors or in places where the Products are exposed to direct sunlight or dust
  - Use of our Products in places where the Products are exposed to sea wind or corrosive gases, including Cl<sub>2</sub>, H<sub>2</sub>S, NH<sub>3</sub>, SO<sub>2</sub>, and NO<sub>2</sub>
  - Use of our Products in places where the Products are exposed to static electricity or electromagnetic waves
  - Use of our Products in proximity to heat-producing components, plastic cords, or other flammable items
  - Sealing or coating our Products with resin or other coating materials
  - Use of our Products without cleaning residue of flux (even if you use no-clean type fluxes, cleaning residue of flux is recommended); or Washing our Products by using water or water-soluble cleaning agents for cleaning residue after soldering
  - Use of the Products in places subject to dew condensation
- The Products are not subject to radiation-proof design.
- Please verify and confirm characteristics of the final or mounted products in using the Products.
- In particular, if a transient load (a large amount of load applied in a short period of time, such as pulse. is applied, confirmation of performance characteristics after on-board mounting is strongly recommended. Avoid applying power exceeding normal rated power; exceeding the power rating under steady-state loading condition may negatively affect product performance and reliability.
- De-rate Power Dissipation (Pd) depending on Ambient temperature (Ta). When used in sealed area, confirm the actual ambient temperature.
- Confirm that operation temperature is within the specified range described in the product specification.
- ROHM shall not be in any way responsible or liable for failure induced under deviant condition from what is defined in this document.

## Precaution for Mounting / Circuit board design

- When a highly active halogenous (chlorine, bromine, etc.) flux is used, the residue of flux may negatively affect product performance and reliability.
- In principle, the reflow soldering method must be used; if flow soldering method is preferred, please consult with the ROHM representative in advance.

For details, please refer to ROHM Mounting specification

**Precautions Regarding Application Examples and External Circuits**

1. If change is made to the constant of an external circuit, please allow a sufficient margin considering variations of the characteristics of the Products and external components, including transient characteristics, as well as static characteristics.
2. You agree that application notes, reference designs, and associated data and information contained in this document are presented only as guidance for Products use. Therefore, in case you use such information, you are solely responsible for it and you must exercise your own independent verification and judgment in the use of such information contained in this document. ROHM shall not be in any way responsible or liable for any damages, expenses or losses incurred by you or third parties arising from the use of such information.

**Precaution for Electrostatic**

This Product is electrostatic sensitive product, which may be damaged due to electrostatic discharge. Please take proper caution in your manufacturing process and storage so that voltage exceeding the Products maximum rating will not be applied to Products. Please take special care under dry condition (e.g. Grounding of human body / equipment / solder iron, isolation from charged objects, setting of Ionizer, friction prevention and temperature / humidity control).

**Precaution for Storage / Transportation**

1. Product performance and soldered connections may deteriorate if the Products are stored in the places where:
  - [a] the Products are exposed to sea winds or corrosive gases, including Cl<sub>2</sub>, H<sub>2</sub>S, NH<sub>3</sub>, SO<sub>2</sub>, and NO<sub>2</sub>
  - [b] the temperature or humidity exceeds those recommended by ROHM
  - [c] the Products are exposed to direct sunshine or condensation
  - [d] the Products are exposed to high Electrostatic
2. Even under ROHM recommended storage condition, solderability of products out of recommended storage time period may be degraded. It is strongly recommended to confirm solderability before using Products of which storage time is exceeding the recommended storage time period.
3. Store / transport cartons in the correct direction, which is indicated on a carton with a symbol. Otherwise bent leads may occur due to excessive stress applied when dropping of a carton.
4. Use Products within the specified time after opening a humidity barrier bag. Baking is required before using Products of which storage time is exceeding the recommended storage time period.

**Precaution for Product Label**

QR code printed on ROHM Products label is for ROHM's internal use only.

**Precaution for Disposition**

When disposing Products please dispose them properly using an authorized industry waste company.

**Precaution for Foreign Exchange and Foreign Trade act**

Since our Products might fall under controlled goods prescribed by the applicable foreign exchange and foreign trade act, please consult with ROHM representative in case of export.

**Precaution Regarding Intellectual Property Rights**

1. All information and data including but not limited to application example contained in this document is for reference only. ROHM does not warrant that foregoing information or data will not infringe any intellectual property rights or any other rights of any third party regarding such information or data. ROHM shall not be in any way responsible or liable for infringement of any intellectual property rights or other damages arising from use of such information or data.:
2. No license, expressly or implied, is granted hereby under any intellectual property rights or other rights of ROHM or any third parties with respect to the information contained in this document.

**Other Precaution**

1. This document may not be reprinted or reproduced, in whole or in part, without prior written consent of ROHM.
2. The Products may not be disassembled, converted, modified, reproduced or otherwise changed without prior written consent of ROHM.
3. In no event shall you use in any way whatsoever the Products and the related technical information contained in the Products or this document for any military purposes, including but not limited to, the development of mass-destruction weapons.
4. The proper names of companies or products described in this document are trademarks or registered trademarks of ROHM, its affiliated companies or third parties.

**General Precaution**

1. Before you use our Products, you are requested to carefully read this document and fully understand its contents. ROHM shall not be in any way responsible or liable for failure, malfunction or accident arising from the use of any ROHM's Products against warning, caution or note contained in this document.
2. All information contained in this document is current as of the issuing date and subject to change without any prior notice. Before purchasing or using ROHM's Products, please confirm the latest information with a ROHM sales representative.
3. The information contained in this document is provided on an "as is" basis and ROHM does not warrant that all information contained in this document is accurate and/or error-free. ROHM shall not be in any way responsible or liable for any damages, expenses or losses incurred by you or third parties resulting from inaccuracy or errors of or concerning such information.

## Looking for pricing, stock, or lifecycle information?

Click below to explore more details on WIN SOURCE:

- [View BD8143MUV-E2 on WIN SOURCE](#)
- [Rohm Semiconductor Information](#)

## Optimize Your Supply Chain with WIN SOURCE Solutions

- ✓ Global Sourcing Solution
- ✓ Obsolete Management
- ✓ Cost Control Management
- ✓ Shortage Management
- ✓ Alternative Solution
- ✓ Excess Inventory Management