

STRUCTURE	Silicon Monolithic Integrated Circuit	
PRODUCT NAME	White LED driver for car navigation back light	
TYPE	<b>BD8118FM</b>	
FEATURES	<ul style="list-style-type: none"> <li>• Step-up DC/DC converter</li> <li>    Built in OSC</li> <li>• 4 parallel current output (output current is set with external resistor)</li> <li>• LED open detection circuit</li> <li>• PWM adjustment</li> <li>• FAIL output (self diagnosis)</li> </ul>	<ul style="list-style-type: none"> <li>• Built in UVLO</li> <li>• Built in OVP</li> <li>• Built in TSD</li> <li>• Built in OCP</li> </ul>

● ABSOLUTE MAXIMUM RATINGS (Ta=25°C)

PARAMETER	SYMBOL	LIMITS	UNIT
Power supply voltage(Pin : 1)	Vcc	36	V
Load switch output voltage(Pin : 2)	VLOADSW	36	V
LED output voltage(Pin : 12, 14, 15, 17)	VLED	36	V
FAIL output voltage(Pin : 3, 20)	VOL	7	V
Input voltage(Pin : 5, 6, 10, 11, 24)	Vin	-0.3~7 < VCC	V
VDAC input voltage(Pin : 8)	VDAC	-0.3~7 < VCC	V
Power dissipation	Pd	2.20 ※1	W
Junction Temperature	Tjmax	150	°C
Operating temperature range	Topr	-40~+95	°C
Storage temperature range	Tstg	-55~+150	°C
LED drive current(Pin : 12, 14, 15, 17)	ILED	150 ※2※3	mA

※1 70mm × 70mm × 1.6mm glass epoxy mounting. Decline by 17.6mw/°C

※2 It is correlate LED drive current with VF dispersion each of current outputs. Refer to the technical note.

※3 Current maximum for 1ch. Do not however exceed Pd.

● Operating range(Ta=25°C)

PARAMETER	SYMBOL	LIMITS	UNIT
Power Supply Voltage(Pin : 1)	Vcc	4.5~30	V
Oscillation frequency(Pin : 26)	Fosc	50~550	kHz
External synchronous frequency(Pin : 6) ※4 ※5	FSYNC	fosc~550	kHz
External synchronous pulse(Pin : 6)	FSDUTY	40~60	%

※4 SYNC have to be connected to GND when external synchronizing frequency is not needed.

※5 Don't change external synchronous frequency to internal oscillation frequency when external synchronous frequency is inputted.

\* This product is not designed for protection against radioactive rays.

● ELECTRICAL CHARACTERISTICS (Unless otherwise specified Ta=25°C, VCC=12V)

PARAMETER	SYMBOL	LIMIT			UNIT	CONDITIONS
		Min	Typ	Max		
Circuit current	I <sub>CC</sub>	2.5	6	10	mA	EN=2V, SYNC=VREG, RT=OPEN PWM=OPEN, ISET=OPEN, C <sub>IN</sub> =1 μF
Standby current	I <sub>ST</sub>	-	0	2	μA	EN=Low
[VREG] (Pin : 4)						
VREG output voltage	V <sub>REG</sub>	4.5	5	5.5	V	I <sub>REG</sub> =-10mA, C <sub>REG</sub> =1 μF
[SW] (Pin : 22, 23)						
SWOUT upper ON resistance	R <sub>ONH</sub>	0.05	3	7	Ω	I <sub>ON</sub> =-10mA
SWOUT lower ON resistance	R <sub>ONL</sub>	0.05	2	5	Ω	I <sub>ON</sub> =10mA
Over current protection limited voltage	V <sub>DCS</sub>	0.3	0.4	0.5	V	V <sub>CS</sub> =sweep up
[error amp] (Pin : 12, 14, 15, 17, 27, 28)						
LED control voltage	V <sub>LED</sub>	0.7	0.8	0.9	V	
COMP sink current	I <sub>SKCP</sub>	40	100	200	μA	V <sub>LED</sub> =2V, V <sub>comp</sub> =1V
COMP source current	I <sub>SCCP</sub>	-200	-100	-40	μA	V <sub>LED</sub> =0V, V <sub>comp</sub> =1V
SS charge current	I <sub>SS</sub>	-14	-10	-6	μA	V <sub>SS</sub> =1.0V
SS maximum voltage	V <sub>MXSS</sub>	2	2.5	3	V	EN=High
SS standby current	I <sub>STSS</sub>	-	0	2	μA	EN=Low
[frequency] (Pin : 23, 26)						
Oscillation frequency	F <sub>OSC</sub>	250	300	350	KHz	R <sub>T</sub> =100k Ω
[OVP] (Pin : 25)						
Over voltage detection voltage	V <sub>DOVP</sub>	1.86	2.0	2.14	V	VOVP=Sweep up
OVP hysteresis range	V <sub>DOHS</sub>	0.35	0.45	0.55	V	VOVP=Sweep down
[UVLO] (Pin : 4)						
UVLO detection voltage	V <sub>DUVLO</sub>	2.5	2.8	3.1	V	V <sub>REG</sub> =Sweep down
UVLO Hysteresis range	V <sub>DUHS</sub>	50	100	200	mV	V <sub>REG</sub> =Sweep up
[Load SW] (Pin : 2)						
Load sw low voltage	V <sub>LDL</sub>	0.05	0.15	0.3	V	I <sub>LOAD</sub> =10mA
[LED output] (Pin : 5, 9, 12, 14, 15, 17, 25)						
LED current relative dispersion width	Δ I <sub>LED1</sub>	-6	0	6	%	I <sub>LED</sub> =50mA
LED current absolute dispersion width	Δ I <sub>LED2</sub>	0	3	6	%	I <sub>LED</sub> =50mA
ISET voltage	V <sub>ISET</sub>	1.96	2.00	2.04	V	I <sub>LED</sub> =50mA
PWM frequency	Duty	0.38	-	99.5	%	F <sub>PWM</sub> =150Hz, I <sub>LED</sub> =50mA ※1, 2, 3
PWM adjustment	F <sub>PWM</sub>	0	-	20	KHz	Duty=50%, I <sub>LED</sub> =50mA ※2, 3
Open detection voltage1	V <sub>DOP1</sub>	0.05	0.15	0.3	V	V <sub>LED</sub> = Sweep down, VOVP>VDOP2, V <sub>SS</sub> ≥VMXSS
Open detection voltage2	V <sub>DOP2</sub>	1.56	1.7	1.84	V	VOVP= Sweep up, V <sub>LED</sub> >VDOP1, V <sub>SS</sub> ≥VMXSS
[Logic input] (Pin : 5, 6, 10, 11, 24)						
Input high voltage	V <sub>INH</sub>	2.6	-	5.5	V	
Input low voltage	V <sub>INL</sub>	GND	-	0.8	V	
Input current	I <sub>IN</sub>	18	35	53	μA	V <sub>IN</sub> =5V (Pin : 5, 6, 10, 11)
Input current	I <sub>EN</sub>	13	25	38	μA	V <sub>EN</sub> =5V (Pin : 24)
[FAIL output] (Pin : 3, 20)						
FAIL low voltage	V <sub>FLL</sub>	0.05	0.1	0.2	V	I <sub>OL</sub> =1mA

◎ This product is not designed for protection against radioactive rays.

※1 0%, 100% input possible

※2 I<sub>LED</sub>=V<sub>DAC</sub> ÷ R<sub>ISET</sub> × 3300

※3 I<sub>LED</sub>=V<sub>ISET</sub> ÷ R<sub>ISET</sub> × 3300, V<sub>DAC</sub>>V<sub>ISET</sub>

● PHYSICAL DIMENSIONS・MARKING

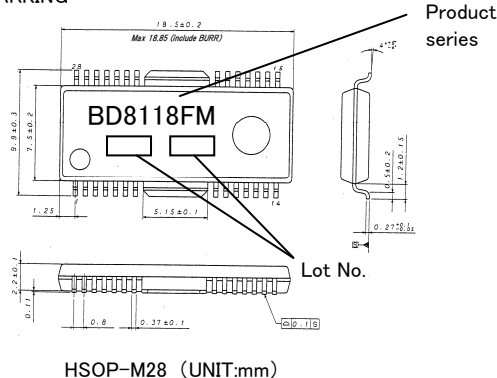

●BLOCK DIAGRAM

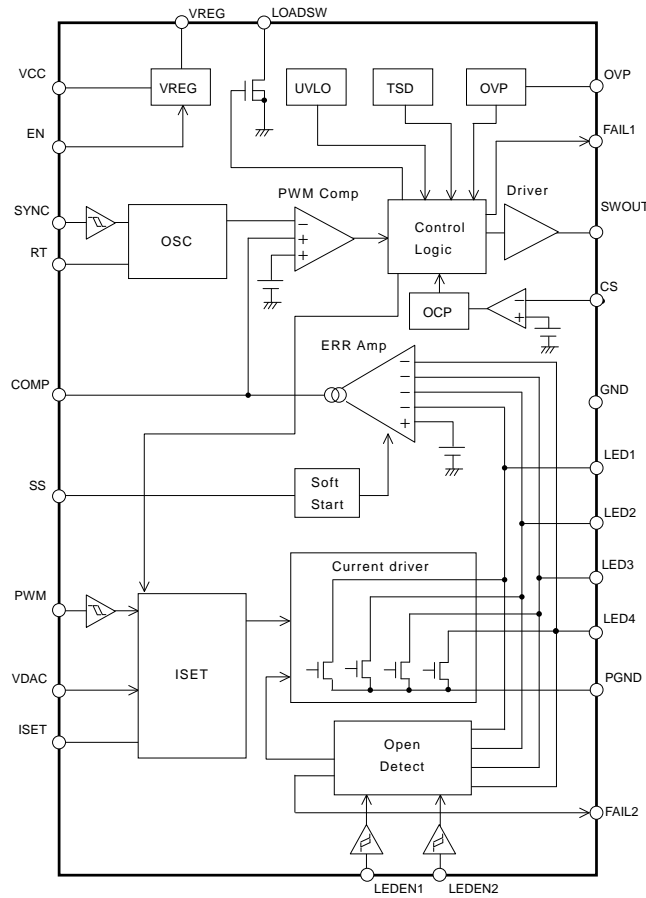

●Pin No, Pin Name, Function

Pin No	Pin Name	Function	Pin No	Pin Name	Function
1	Vcc	Power supply	15	LED3	LED output (Open Drain)
2	LOADSW	FET pin for load sw (Open Drain)	16	-	N.C.
3	FAIL1	Fail signal output (Open Drain)	17	LED4	LED output (Open Drain)
4	VREG	Internal voltage regulator	18	-	N.C.
5	PWM	PWM adjustment input	19	-	N.C.
6	SYNC	External synchronizing input	20	FAIL2	Fail signal output (Open det : Open Drain)
7	GND	Ground pin	21	PGND	LED output GND pin
8	VDAC	DC flexible input	22	CS	DC/DC output current detection pin
9	ISET	LED output current set resistor	23	SWOUT	DC/DC SW output pin
10	LEDEN1	LED output enable pin1	24	EN	Enable pin
11	LEDEN2	LED output enable pin2	25	OVP	OVP pin over voltage detection pin
12	LED1	LED output (Open Drain)	26	RT	Frequency set resistor
13	-	N.C.	27	SS	Softstart pin
14	LED2	LED output (Open Drain)	28	COMP	Error amp output

● Operation Notes

- (1) Absolute maximum ratings  
Use of the IC in excess of absolute maximum ratings such as the applied voltage or operating temperature range may result in IC damage. Assumptions should not be made regarding the state of the IC (short mode or open mode) when such damage is suffered. A physical safety measure such as a fuse should be implemented when use of the IC in a special mode where the absolute maximum ratings may be exceeded is anticipated.
- (2) Reverse connection of a power supply connector  
If the connector of power is wrong connected, it may result in IC breakage. In order to prevent the breakage from the wrong connection, the diode should be connected between external power and the power terminal of IC as protection solution.
- (3) Power supply and ground lines.  
Fluctuating voltage on the power supply and ground lines may damage the device. Be sure to connect a bypass filter capacitor as close as possible to the IC between the power supply and ground pins. Check that the selected capacitance will not have an adverse influence on any characteristics, such as a drop in the electrolytic capacitor value that can occur at low temperatures.
- (4) GND potential  
Ensure a minimum GND pin potential in all operating conditions.
- (5) Setting of heat  
Use a setting of heat that allows for a sufficient margin in light of the power dissipation (Pd) in actual operating conditions.
- (6) Pin short and mistake fitting  
Use caution when orienting and positioning the IC for mounting on printed circuit boards. Improper mounting may result in damage to the IC. Use of the IC in excess of absolute maximum ratings such as the applied voltage or operating temperature range may result in IC damage.
- (7) Actions in strong magnetic field  
Use caution when using the IC in the presence of a strong electromagnetic field as doing so may cause the IC to malfunction.
- (8) Thermal shutdown circuit(TSD)  
This IC built-in a Thermal shutdown circuit (TSD circuit). If Chip temperature becomes 175°C(TYP.), make the output an Open state. Eventually, warmly clearing the circuit is decided by the condition of whether the heat excesses over the assigned limit, resulting the cutoff of the circuit of IC, and not by the purpose of preventing and ensuring the IC. Therefore, the warm switch-off should not be applied in the premise of continuous employing and operation after the circuit is switched on.
- (9) Testing on application boards  
When testing the IC on an application board, connecting a capacitor to a pin with low impedance subjects the IC to stress. Always discharge capacitors after each process or step. Ground the IC during assembly steps as an antistatic measure, and use similar caution when transporting or storing the IC. Always turn the IC's power supply off before connecting it to or removing it from a jig or fixture during the inspection process
- (10) IC terminal input  
This monolithic IC contains P+ isolation and P substrate layers between adjacent elements in order to keep them isolated. P/N junctions are formed at the intersection of these P layers with the N layers of other elements to create a variety of parasitic elements.  
For example, when a resistor and transistor are connected to pins. (See the chart below.)  
○ the P/N junction functions as a parasitic diode when  $GND > (Pin A)$  for the resistor or  $GND > (Pin B)$  for the transistor (NPN).  
○ Similarly, when  $GND > (Pin B)$  for the transistor (NPN), the parasitic diode described above combines with the N layer of other adjacent elements to operate as a parasitic NPN transistor.  
The formation of parasitic elements as a result of the relationships of the potentials of different pins is an inevitable result of the IC's architecture. The operation of parasitic elements can cause interference with circuit operation as well as IC malfunction and damage. For these reasons, it is necessary to use caution so that the IC is not used in a way that will trigger the operation of parasitic elements, such as by the application of voltages lower than the GND (PCB) voltage to input pins.

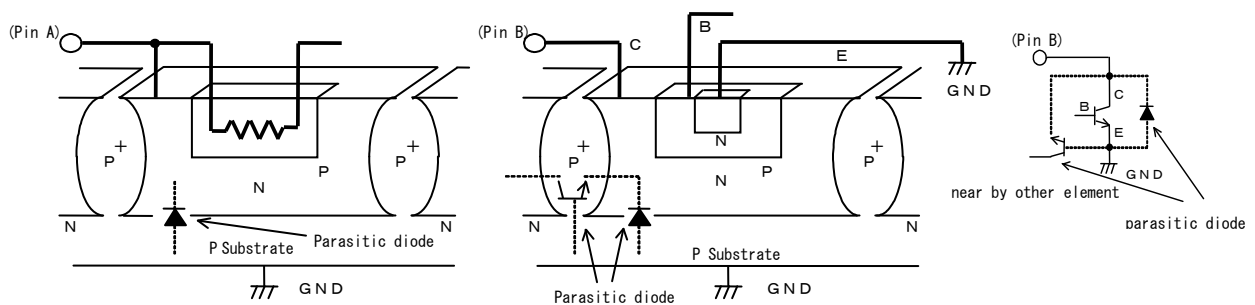

Fig of chart of Parasitic diode

- (11) Ground wiring patterns  
When using both small signal and large current GND patterns, it is recommended to isolate the two ground patterns, placing a single ground point at the application's reference point so that the pattern wiring resistance and voltage variations caused by large currents do not cause variations in the small signal ground voltage. Be careful not to change the GND wiring patterns of any external components.
- (12) LED output terminal  
Don't connect Capacitor to LED output terminal (Pin : 12,14,15,17), as doing so may cause LED short detection to malfunction.

## Notes

No copying or reproduction of this document, in part or in whole, is permitted without the consent of ROHM Co.,Ltd.

The content specified herein is subject to change for improvement without notice.

The content specified herein is for the purpose of introducing ROHM's products (hereinafter "Products"). If you wish to use any such Product, please be sure to refer to the specifications, which can be obtained from ROHM upon request.

Examples of application circuits, circuit constants and any other information contained herein illustrate the standard usage and operations of the Products. The peripheral conditions must be taken into account when designing circuits for mass production.

Great care was taken in ensuring the accuracy of the information specified in this document. However, should you incur any damage arising from any inaccuracy or misprint of such information, ROHM shall bear no responsibility for such damage.

The technical information specified herein is intended only to show the typical functions of and examples of application circuits for the Products. ROHM does not grant you, explicitly or implicitly, any license to use or exercise intellectual property or other rights held by ROHM and other parties. ROHM shall bear no responsibility whatsoever for any dispute arising from the use of such technical information.

The Products specified in this document are intended to be used with general-use electronic equipment or devices (such as audio visual equipment, office-automation equipment, communication devices, electronic appliances and amusement devices).

The Products specified in this document are not designed to be radiation tolerant.

While ROHM always makes efforts to enhance the quality and reliability of its Products, a Product may fail or malfunction for a variety of reasons.

Please be sure to implement in your equipment using the Products safety measures to guard against the possibility of physical injury, fire or any other damage caused in the event of the failure of any Product, such as derating, redundancy, fire control and fail-safe designs. ROHM shall bear no responsibility whatsoever for your use of any Product outside of the prescribed scope or not in accordance with the instruction manual.

The Products are not designed or manufactured to be used with any equipment, device or system which requires an extremely high level of reliability the failure or malfunction of which may result in a direct threat to human life or create a risk of human injury (such as a medical instrument, transportation equipment, aerospace machinery, nuclear-reactor controller, fuel-controller or other safety device). ROHM shall bear no responsibility in any way for use of any of the Products for the above special purposes. If a Product is intended to be used for any such special purpose, please contact a ROHM sales representative before purchasing.

If you intend to export or ship overseas any Product or technology specified herein that may be controlled under the Foreign Exchange and the Foreign Trade Law, you will be required to obtain a license or permit under the Law.





Thank you for your accessing to ROHM product informations.  
More detail product informations and catalogs are available, please contact us.

## ROHM Customer Support System

<http://www.rohm.com/contact/>

## Looking for pricing, stock, or lifecycle information?

Click below to explore more details on WIN SOURCE:

-  [View BD8118FM-E2 on WIN SOURCE](#)
-  [Rohm Semiconductor](#) Information

## Optimize Your Supply Chain with WIN SOURCE Solutions

-  Global Sourcing Solution
-  Obsolete Management
-  Cost Control Management
-  Shortage Management
-  Alternative Solution
-  Excess Inventory Management