

Power Management ICs for Automotive Body Control

LED Indicator Driver



BD8105FV

No.11039ECT01

●Description

The BD8105FV is a serial parallel control LED driver with 35V input voltage rating. Responding to the 3-line serial data, it turns the 12ch open drain output on/off. Due to its compact size, it is optimal for small spaces.

●Features

- 1) Open Drain Output
- 2) 3-line Serial Control + Enable Signal
- 3) Internal Temperature Protection Circuit (TSD)
- 4) Cascade Connection Compatible
- 5) SSOP-B20W
- 6) Internal 12 ch Power Transistor

●Applications

These ICs can be used with car and consumer electronic.

●Absolute Maximum Ratings (Ta=25°C)

Parameter	Symbol	Ratings	Unit
Power Supply Voltage	VCC	7	V
Output Voltage(Pin No : 4~9, 11~16)	VDmax	35	V
Input Voltage(Pin No : 1, 2, 3, 17, 18)	VIN	-0.3~VCC	V
Power Dissipation	Pd	1187*	mW
Operating Temperature Range	Topr	-40~+105	°C
Storage Temperature Range	Tstg	-55~+150	°C
Drive Current (DC)	IomaxD	50	mA
Drive Current(Pulse)	IomaxP	150**	mA
Junction Temperature	Tjmax	150	°C

* Pd decreased at 9.50mW/°C for temperatures above Ta=25°C, mounted on 70x70x1.6mm Glass-epoxy PCB.

** Do not however exceed Pd. Time to impress ≤ 200msec

●Operational Conditions (Ta=-40~105°C)

Parameter	Symbol	Ratings			Unit
		Min.	Typ.	Max.	
Power Supply Voltage	Vcc	4.5	5	5.5	V
Drive Current	Io	-	20	40	mA

* This product is not designed for protection against radioactive rays.

●Electrical Characteristics (Unless specified, Ta=-40~105°C Vcc=4.5~5.5V)

Parameter	Symbol	Limits			Unit	Conditions
		Min.	Typ.	Max.		
【Output D0~D11】 (Pin No : 4~9, 11~16)						
ON Resistor	RON	-	6	12	Ω	Id=20mA
Output leakage current	IDL	-	0	5	μA	V _D =34V
【Logic input】 (Pin No : 1, 2, 3, 17, 18)						
Upper limit threshold voltage	VTH	Vcc x0.8	-	-	V	
Bottom limit threshold voltage	VTL	-	-	Vcc x0.2	V	
Serial clock frequency	FCLK	-	-	1	MHz	
Input Current	IIN	20	50	100	μA	VIN=5V
Input leakage Current	IINL	-	0	5	μA	VIN=0V
【WHOLE】						
Circuit Current	ICC	-	0.3	5	mA	Serial Data Input, VCC=5V,CLK=500KHz, SEROUT=OPEN
Static Current	ISTN	-	0	50	μA	RST_B=OPEN, SEROUT=OPEN
【SER OUT】 (Pin No. : 20)						
Output Voltage high	VOH	4.6	4.8	-	V	VCC=5V, ISO=-5mA
Output voltage Low	VOL	-	0.2	0.4	V	VCC=5V, ISO=5mA

* This product is not designed for protection against radioactive rays.

● Electrical Characteristic Diagrams (Unless otherwise specified Ta=25°C)

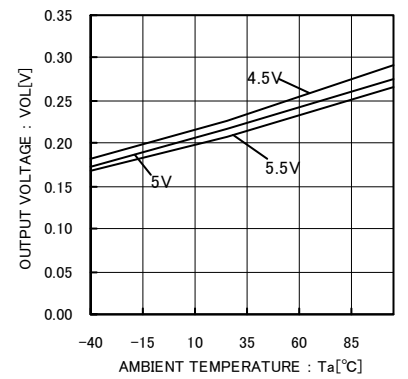
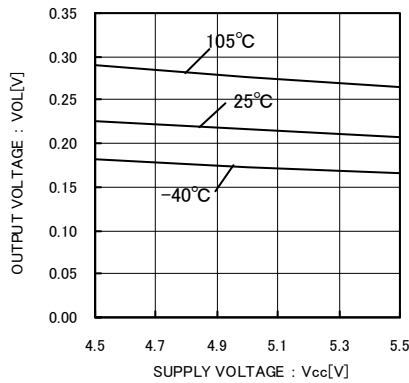
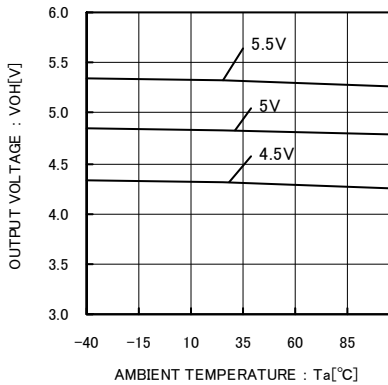
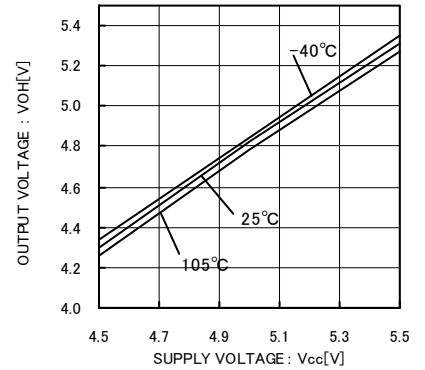
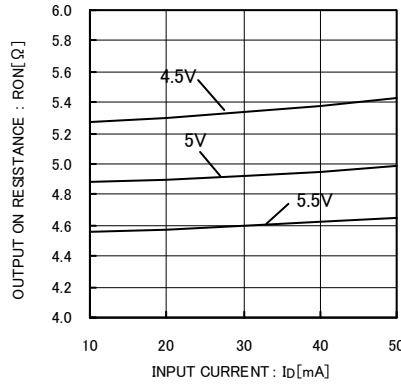
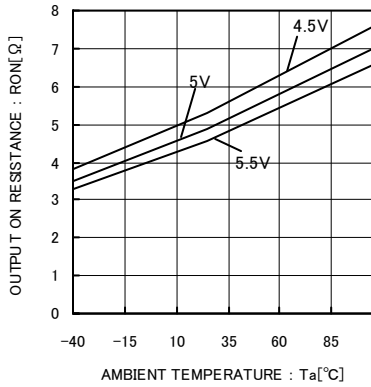
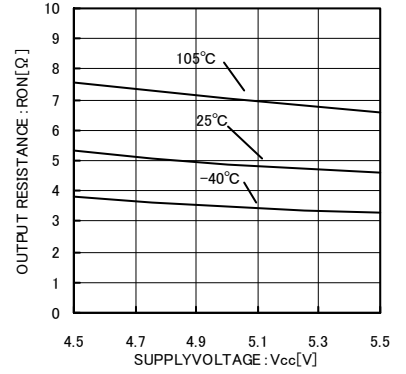
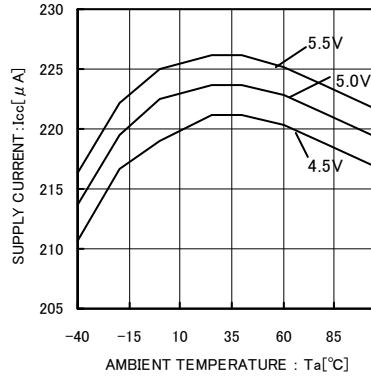
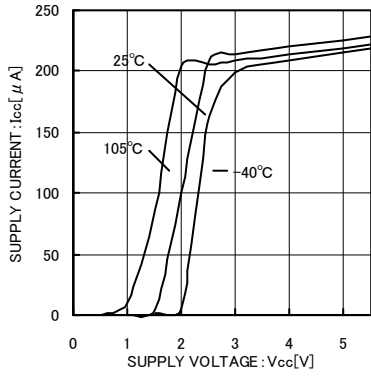

●Block Diagram

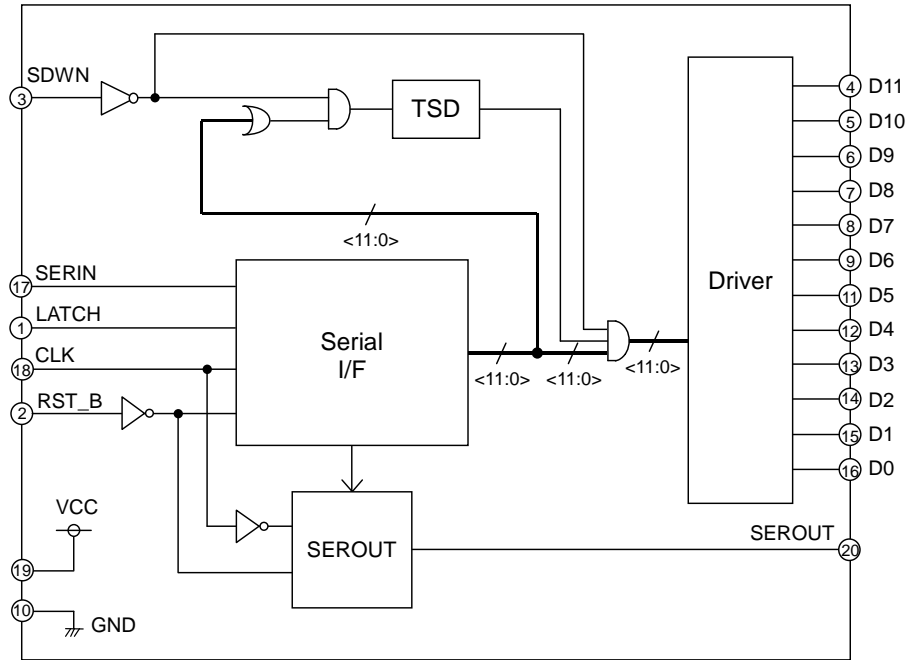

Fig.10

●Pin Setup Diagram

BD8105FV(SSOP-B20W)

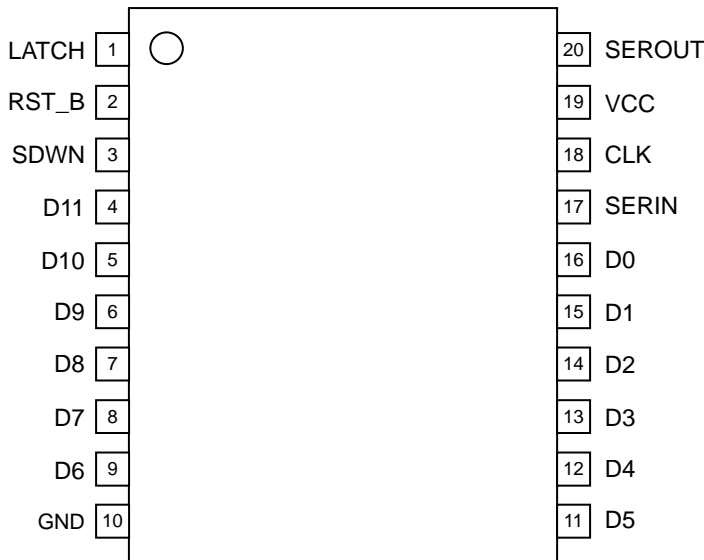

Fig.11

●Terminal Number • Terminal Name

Pin Number	Terminal Name	Function
1	LATCH	Latch Signal Input Terminal (H: Latches Data)
2	RST_B	Reset Reversal Input Terminal (L: FF Data 0)
3	SDWN	Shutdown Input Terminal (H: Output Off)
4	D11	Drain Output Terminal 11
5	D10	Drain Output Terminal 10
6	D9	Drain Output Terminal 9
7	D8	Drain Output Terminal 8
8	D7	Drain Output Terminal 7
9	D6	Drain Output Terminal 6
10	GND	Ground Terminal
11	D5	Drain Output Terminal 5
12	D4	Drain Output Terminal 4
13	D3	Drain Output Terminal 3
14	D2	Drain Output Terminal 2
15	D1	Drain Output Terminal 1
16	D0	Drain Output Terminal 0
17	SERIN	Serial Data Input Terminal
18	CLK	Clock Input Terminal
19	VCC	Supply Voltage Input Terminal
20	SEROUT	Serial Data Output Terminal

●Block Operation

1)Serial I/F

The I/F is a 3-line serial (LATCH, CLK, SERIN) style.

12-bit output ON/OFF can be set-up. This is composed of shift register. + 12-bit register.

2)Driver

It is a 12-bit open drain output.

3)TSD (Thermal Shut Down)

To prevent heat damage and overheating, when the chip temperature goes over approximately 175°C, the output turns off. When the temperature goes back down, normal operation resumes. However, the intended use of the temperature protection circuit is to protect the IC, so please construct thermal design with the junction temperature Tjmax under 150°C.

●Application Circuit

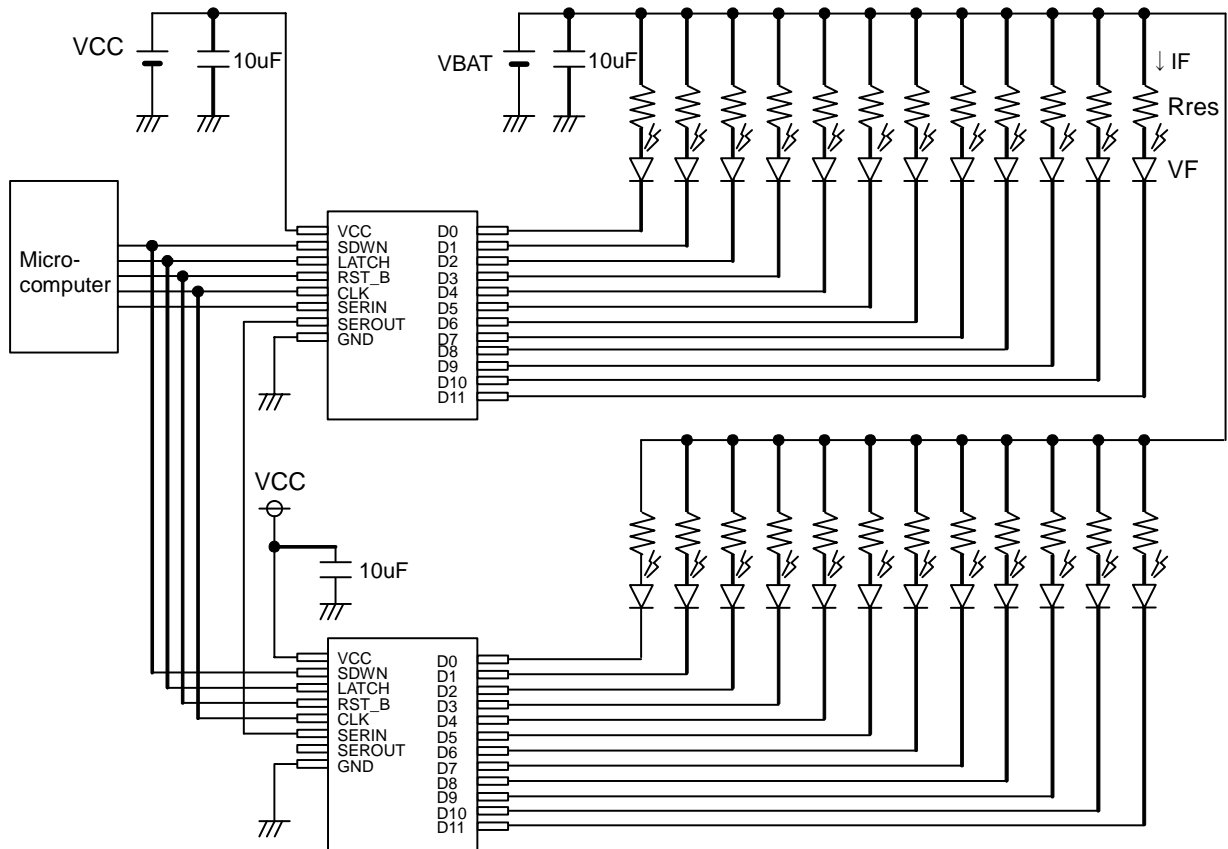

$$IF = \frac{VBAT - VF}{Rres + RON}$$

Fig.12

3)Enable Signal

By applying voltage at least $VCC \times 0.8$ or more to the SDWN terminal, D0 (16 pin)~D11 (4 pin) become open forcibly. At this time, the temperature protection circuit (TSD) stops. D11~D0 become PWM operation by inputting PWM to SDWN(3 pin).

4)SEROUT

A cascade connection can be made (connecting at least 2 or more IC's in serial). Serial signal input from SERIN is transferred into receiver IC by the fall edge of the CLK signal. Since this functionality gives enough margins for the setup time prior to the rise edge of the CLK signal on the receiver IC (using the exact same CLK signal of sender IC), the application reliability can be improved as cascade connection functionality.

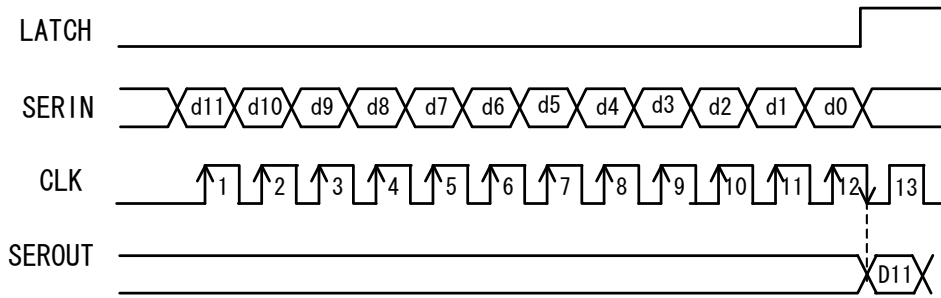

Fig.14

●Cascade Connection

By using (at least) 2 ICs, each IC's D11~D0, at (at least) 24ch, can be controlled by the 24-bit SERIN signal. The serial data input to the sender IC can be transferred to the receiver IC by inputting 12CLK to the CLK terminal.

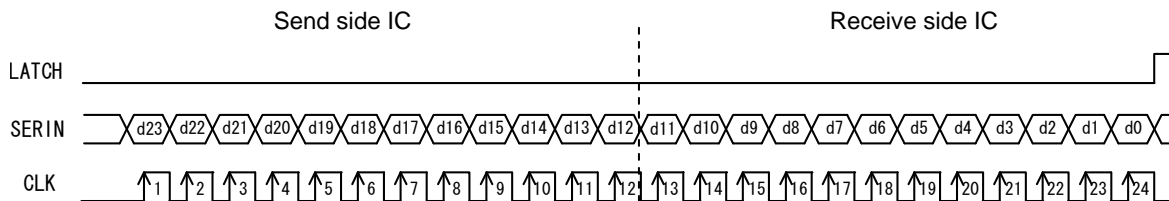

Fig.15

●INPUT SIGNAL'S TIMING CHART

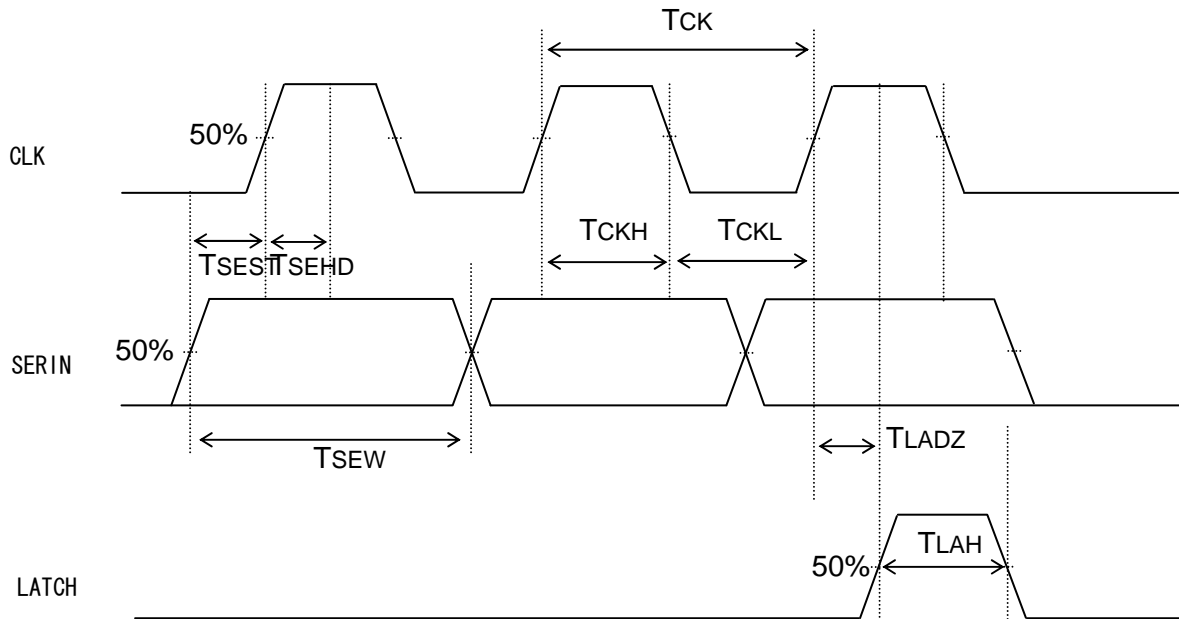

Fig.16

●INPUT SIGNAL'S TIMING RULE(Ta=-40~105°C Vcc=4.5~5.5V)

Parameter	Symbol	Min	Unit
CLK period	TCK	1000	ns
CLK high pulse width	TCKH	480	ns
CLK low pulse width	TCKL	480	ns
SERIN high and low pulse width	TSEW	980	ns
SERIN setup time prior to CLK rise	TSEST	150	ns
SERIN hold time after CLK fall	TSEHD	150	ns
LATCH high pulse time	TLAH	480	ns
Last CLK rise to LATCH rise	TLADZ	250	ns

●OUTPUT SIGNAL'S DELAY CHART

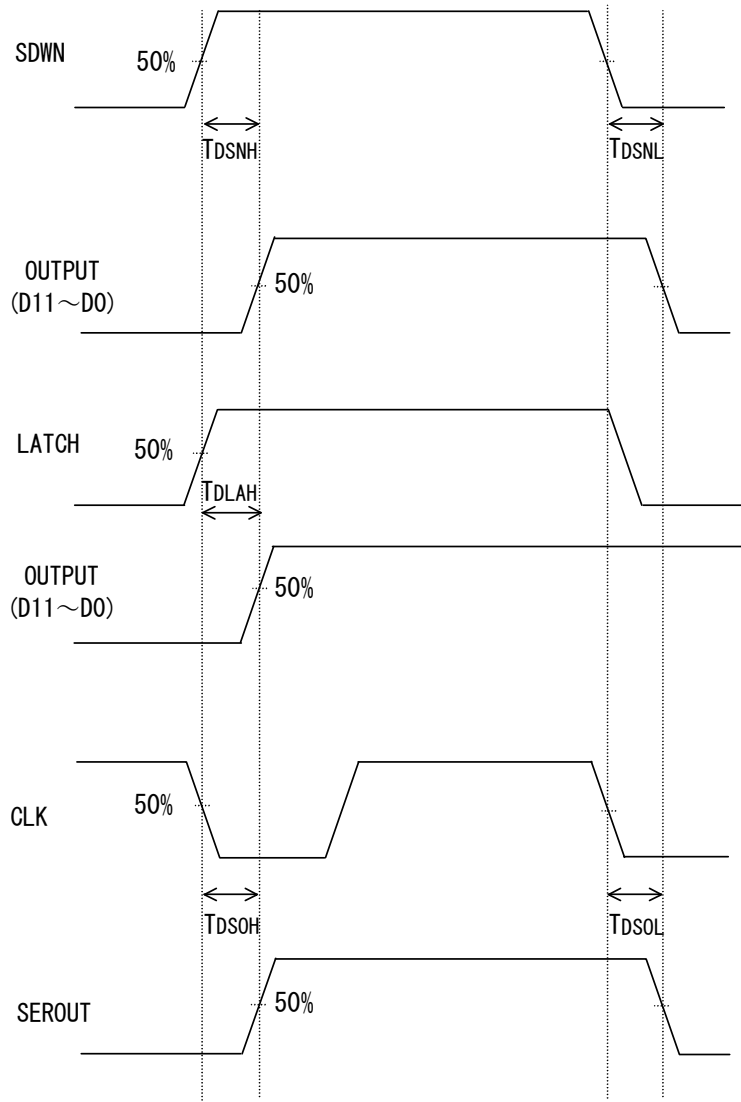

Fig.17

●OUTPUT SIGNAL'S DELAY TIME(Ta=-40~105°C Vcc=4.5~5.5V)

Parameter	Symbol	Max	Unit
SDWN Switching Time(L→H)	TDSNH	300	ns
SDWN Switching Time(H→L)	TDSNL	300	ns
LATCH Switching Delay Time	TDLAH	300	ns
SEROUT Propagation Delay Time(L→H)	TDSOH	350	ns
SEROUT Propagation Delay Time (H→L)	TDSOL	350	ns

●INPUT/OUTPUT EQUIVALENT CIRCUIT(PIN NAME)

<p>1PIN(LATCH) 2PIN(RST_B) 3PIN(SDWN) 17PIN(SERIN) 18PIN(CLK)</p>	<p>4PIN(D11),5PIN(D10) 6PIN(D9),7PIN(D8) 8PIN(D7),9PIN(D6) 11PIN(D5),12PIN(D4) 13PIN(D3),14PIN(D2) 15PIN(D1),16PIN(D0)</p>	<p>20PIN(SEROUT)</p>
		

Fig.18

●Notes for use

- (1) Absolute maximum ratings
Use of the IC in excess of absolute maximum ratings such as the applied voltage or operating temperature range may result in IC damage. Assumptions should not be made regarding the state of the IC (short mode or open mode) when such damage is suffered. A physical safety measure such as a fuse should be implemented when use of the IC in a special mode where the absolute maximum ratings may be exceeded is anticipated.
- (2) Reverse connection of a power supply connector
If the connector of power is wrong connected, it may result in IC breakage. In order to prevent the breakage from the wrong connection, the diode should be connected between external power and the power terminal of IC as protection solution.
- (3) GND potential
Ensure a minimum GND pin potential in all operating conditions.
- (4) Setting of heat
Use a setting of heat that allows for a sufficient margin in light of the power dissipation (P_d) in actual operating conditions.
- (5) Pin short and mistake fitting
Use caution when orienting and positioning the IC for mounting on printed circuit boards. Improper mounting may result in damage to the IC. Use of the IC in excess of absolute maximum ratings such as the applied voltage or operating temperature range may result in IC damage.
- (6) Actions in strong magnetic field
Use caution when using the IC in the presence of a strong electromagnetic field as doing so may cause the IC to malfunction.
- (7) Thermal shutdown circuit(TSD)
This IC built-in a Thermal shutdown circuit (TSD circuit). If Chip temperature becomes 175°C (TYP.), make the output an Open state. Eventually, warmly clearing the circuit is decided by the condition of whether the heat excesses over the assigned limit, resulting the cutoff of the circuit of IC, and not by the purpose of preventing and ensuring the IC. Therefore, the warm switch-off should not be applied in the premise of continuous employing and operation after the circuit is switched on.
- (8) Testing on application boards
When testing the IC on an application board, connecting a capacitor to a pin with low impedance subjects the IC to stress. Always discharge capacitors after each process or step. Ground the IC during assembly steps as an antistatic measure, and use similar caution when transporting or storing the IC. Always turn the IC's power supply off before connecting it to or removing it from a jig or fixture during the inspection process
- (9) IC terminal input

This monolithic IC contains P+ isolation and P substrate layers between adjacent elements in order to keep them isolated. P/N junctions are formed at the intersection of these P layers with the N layers of other elements to create a variety of parasitic elements. For example, when a resistor and transistor are connected to pins. (See the chart below.)

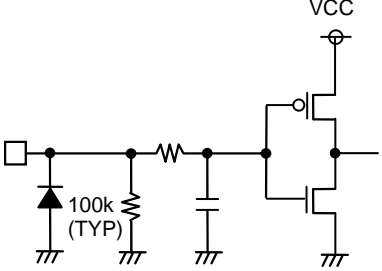
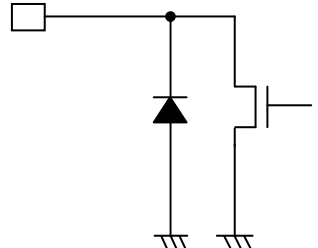
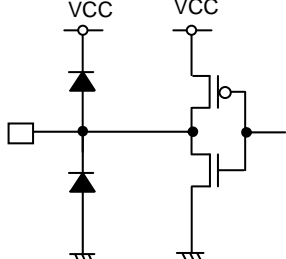
○The P/N junction functions as a parasitic diode when

GND > (Pin A) for the resistor or GND > (Pin B) for the transistor (NPN).

○Similarly, when GND > (Pin B) for the transistor (NPN), the parasitic diode described above combines with the N layer of other adjacent elements to operate as a parasitic NPN transistor.

The formation of parasitic elements as a result of the relationships of the potentials of different pins is an inevitable result of the IC's architecture. The operation of parasitic elements can cause interference with circuit operation as well as IC malfunction and damage. For these reasons, it is necessary to use caution so that the IC is not used in a way that will trigger the operation of parasitic elements, such as by the application of voltages lower than the GND (PCB) voltage to input pins.

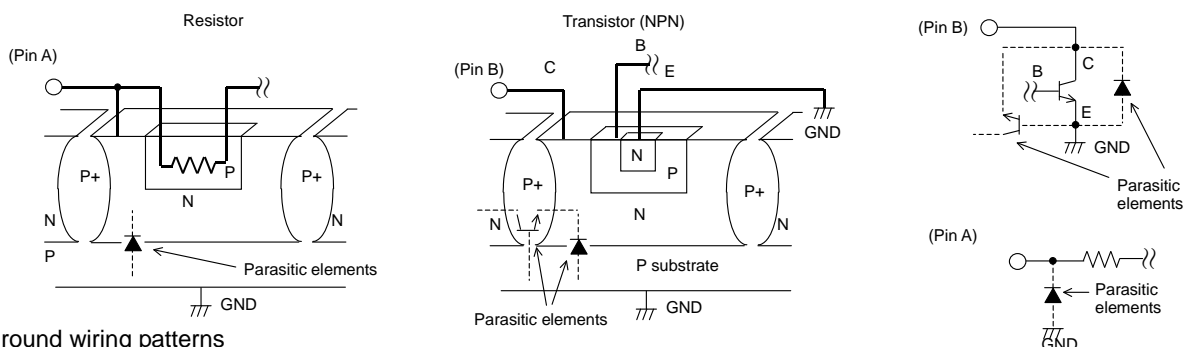

- (10) Ground wiring patterns

When using both small signal and large current GND patterns, it is recommended to isolate the two ground patterns, placing a single ground point at the application's reference point so that the pattern wiring resistance and voltage variations caused by large currents do not cause variations in the small signal ground voltage. Be careful not to change the GND wiring patterns of any external components.

●Ordering part number

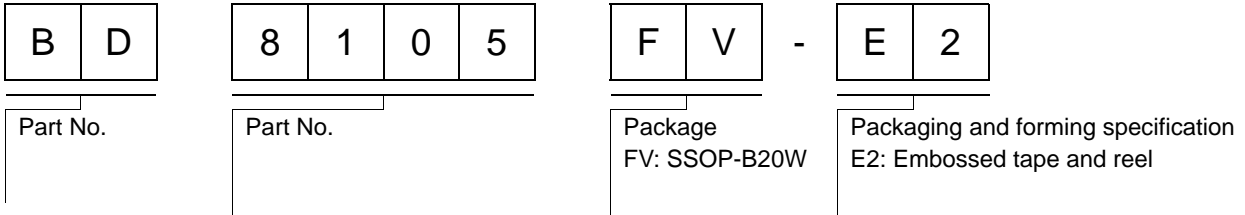

SSOP-B20W

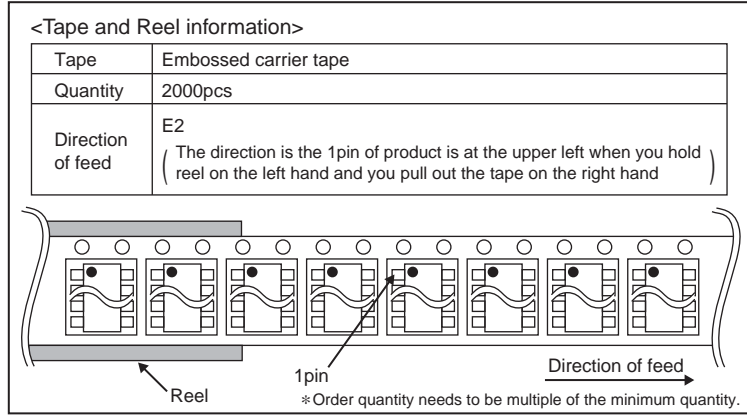
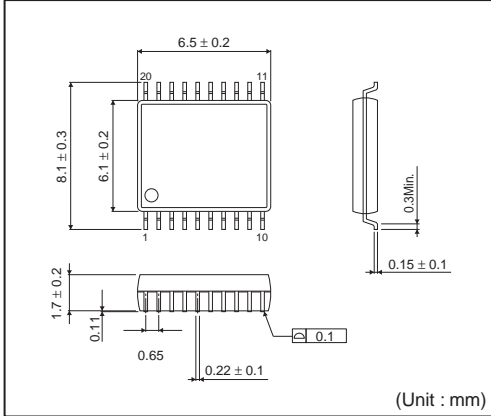

Notes

No copying or reproduction of this document, in part or in whole, is permitted without the consent of ROHM Co.,Ltd.

The content specified herein is subject to change for improvement without notice.

The content specified herein is for the purpose of introducing ROHM's products (hereinafter "Products"). If you wish to use any such Product, please be sure to refer to the specifications, which can be obtained from ROHM upon request.

Examples of application circuits, circuit constants and any other information contained herein illustrate the standard usage and operations of the Products. The peripheral conditions must be taken into account when designing circuits for mass production.

Great care was taken in ensuring the accuracy of the information specified in this document. However, should you incur any damage arising from any inaccuracy or misprint of such information, ROHM shall bear no responsibility for such damage.

The technical information specified herein is intended only to show the typical functions of and examples of application circuits for the Products. ROHM does not grant you, explicitly or implicitly, any license to use or exercise intellectual property or other rights held by ROHM and other parties. ROHM shall bear no responsibility whatsoever for any dispute arising from the use of such technical information.

The Products specified in this document are intended to be used with general-use electronic equipment or devices (such as audio visual equipment, office-automation equipment, communication devices, electronic appliances and amusement devices).

The Products specified in this document are not designed to be radiation tolerant.

While ROHM always makes efforts to enhance the quality and reliability of its Products, a Product may fail or malfunction for a variety of reasons.

Please be sure to implement in your equipment using the Products safety measures to guard against the possibility of physical injury, fire or any other damage caused in the event of the failure of any Product, such as derating, redundancy, fire control and fail-safe designs. ROHM shall bear no responsibility whatsoever for your use of any Product outside of the prescribed scope or not in accordance with the instruction manual.

The Products are not designed or manufactured to be used with any equipment, device or system which requires an extremely high level of reliability the failure or malfunction of which may result in a direct threat to human life or create a risk of human injury (such as a medical instrument, transportation equipment, aerospace machinery, nuclear-reactor controller, fuel-controller or other safety device). ROHM shall bear no responsibility in any way for use of any of the Products for the above special purposes. If a Product is intended to be used for any such special purpose, please contact a ROHM sales representative before purchasing.

If you intend to export or ship overseas any Product or technology specified herein that may be controlled under the Foreign Exchange and the Foreign Trade Law, you will be required to obtain a license or permit under the Law.



Thank you for your accessing to ROHM product informations.
More detail product informations and catalogs are available, please contact us.

ROHM Customer Support System

<http://www.rohm.com/contact/>



Looking for pricing, stock, or lifecycle information?

Click below to explore more details on WIN SOURCE:

- [View BD8105FV-E2 on WIN SOURCE](#)
- [Rohm Semiconductor Information](#)

Optimize Your Supply Chain with WIN SOURCE Solutions

- ✓ Global Sourcing Solution
- ✓ Obsolete Management
- ✓ Cost Control Management
- ✓ Shortage Management
- ✓ Alternative Solution
- ✓ Excess Inventory Management